

CALIFORNIA REGIONAL WATER QUALITY CONTROL BOARD

COLORADO RIVER BASIN REGION

73-720 Fred Waring Drive, Suite 100, Palm Desert, CA 92260
Phone: (760) 346-7491 • Fax (760) 341-6820
<http://www.waterboards.ca.gov/coloradoriver>

ORDER NO. R7-2007-0034
NPDES NO. CA0105007

**WASTE DISCHARGE REQUIREMENTS
FOR THE
CITY OF WESTMORLAND, WESTMORLAND WASTEWATER TREATMENT PLANT**

The following Discharger is subject to Waste Discharge Requirements (WDRs) as set forth in this Order:

Table 1. Discharger Information

Discharger	City of Westmorland
Name of Facility	Westmorland Wastewater Treatment Plant
Facility Address	5305 Martin Road
	Westmorland, CA 92281
	Imperial County
The U.S. Environmental Protection Agency (USEPA) and the Regional Water Quality Control Board have classified this discharge as a minor discharge.	

The discharge by the City of Westmorland, from the discharge point identified below is subject to WDRs as set forth in this Order:

Table 2. Discharge Location

Discharge Point	Effluent Description	Discharge Point Latitude	Discharge Point Longitude	Receiving Water
001	Secondary treated domestic wastewater	33° 02' 45" N	115° 37' 44" W	Trifolium Drain No. 6

Table 3. Administrative Information

This Order was adopted by the Regional Water Quality Control Board on:	September 19, 2007
This Order shall become effective on:	September 19, 2007
This Order shall expire on:	September 19, 2012
The Discharger shall file a Report of Waste Discharge (ROWD) in accordance with title 23, CCRs, as application for issuance of new waste discharge requirements no later than:	180 days prior to the Order expiration date

IT IS HEREBY ORDERED, that Order No. R7-2002-0004 is rescinded upon the effective date of this Order except for enforcement purposes, and, in order to meet the provisions contained in Division 7 of the Water Code (commencing with Section 13000) and regulations adopted thereunder, and the provisions of the federal Clean Water Act (CWA) (33 U.S.C. § 1251 et seq.) and regulations and guidelines adopted thereunder, the Discharger shall comply with the requirements in this Order.

I, Robert Perdue, Executive Officer, do hereby certify that this Order with all attachments is a full, true, and correct copy of an Order adopted by the California Regional Water Quality Control Board, Colorado River Basin Region, on September 19, 2007.

A handwritten signature in black ink, appearing to read "Robert E. Perdue", written over a horizontal line.

ROBERT PERDUE, Executive Officer

Table of Contents

I. Facility Information 4
 II. Findings 5
 III. Discharge Prohibitions 11
 IV. Effluent Limitations and Discharge Specifications 12
 A. Effluent Limitations – Discharge Point 001 12
 B. Land Discharge Specifications – Not Applicable 14
 C. Reclamation Specifications – Not Applicable 14
 V. Receiving Water Limitations 15
 A. Surface Water Limitations 15
 B. Groundwater Limitations – Not Applicable 16
 VI. Provisions 17
 A. Standard Provisions 17
 B. Monitoring and Reporting Program (MRP) Requirements 18
 C. Special Provisions 18
 1. Reopener Provisions 18
 2. Special Studies, Technical Reports and Additional Monitoring Requirements 19
 3. Best Management Practices and Pollution Prevention 21
 4. Construction, Operation and Maintenance Specifications 22
 5. Special Provisions for Municipal Facilities (POTWs Only) 23
 6. Other Special Provisions 24
 7. Compliance Schedules 24
 VII. Compliance Determination 26

List of Tables

Table 1. Discharger Information 1
 Table 2. Discharge Location 1
 Table 3. Administrative Information 1
 Table 4. Facility Information 4
 Table 5. Basin Plan Beneficial Uses 7
 Table 6. Effluent Limitations 12
 Table 7. Interim Effluent Limitations 14
 Table 8. Compliance Schedule 25

List of Attachments

Attachment A – Definitions A-1
 Attachment B – Map B-1
 Attachment C – Flow Schematic C-1
 Attachment D – Standard Provisions D-1
 Attachment E – Monitoring and Reporting Program E-1
 Attachment F – Fact Sheet F-1
 Attachment G – List of Priority Pollutants G-8
 Attachment H – State Water Board Minimum Levels H-8
 Attachment I – Summary of WQBELS Calculations I-8

I. FACILITY INFORMATION

The following Discharger is subject to WDRs as set forth in this Order:

Table 4. Facility Information

Discharger	City of Westmorland
Name of Facility	Westmorland Wastewater Treatment Plant
Facility Address	5305 Martin Road
	Westmorland, CA 92281
	Imperial County
Facility Contact, Title, and Phone	Lucas G. Agatep, Chief Operator (760) 344-0146
Mailing Address	City of Westmorland, P.O. Box 699, Westmorland, CA 92281
Type of Facility	Publicly Owned Treatment Works (POTW)
Facility Design Flow	0.50 million gallons per day (MGD)

II. FINDINGS

The California Regional Water Quality Control Board, Colorado River Basin Region (hereinafter Regional Water Board), finds:

- A. Background.** The City of Westmorland (hereinafter Discharger) is currently discharging pursuant to Order No. R7-2002-0004 and NPDES Permit No. CA0105007. The Discharger submitted a ROWD, dated September 26, 2006 and applied for an NPDES permit renewal to discharge up to 0.50 MGD of treated wastewater from the City of Westmorland Wastewater Treatment Plant, hereinafter Facility. Additional information was requested from the Discharger on February 4, 2007. In response, the Board received a request from the Discharger on January 26, 2007 for a 30-day extension to submit the information required to finalize the processing of the City's renewal application. The additional information was provided on March 13, 2007. The application was deemed complete on March 13, 2007.

For the purposes of this Order, references to "Discharger" or "permittee" in applicable federal and state laws, regulations, plans, or policy are held to be equivalent to references to the Discharger herein.

- B. Facility Description.** The Discharger owns and operates a wastewater collection and disposal system and provides a sewerage service to the City of Westmorland which is located in the Imperial Valley, south of the Salton Sea. The wastewater collection and disposal system serves a population of 2,400. The treatment system consists of a sewage pump station, an influent flow meter, an oxidation ditch, two twenty-eight foot clarifiers, chlorine contact chambers, dechlorination operations and constructed wetlands. The Discharger may divert all of the chlorinated effluent flow, a portion of, or no flow to the constructed wetlands prior to the discharge to Trifolium Drain No. 6.

The constructed wetlands consist of two, 2-acre unlined wetland ponds which became operational on January 1, 2007. The two, unlined wetland ponds operate in parallel. The wetlands have a series of deep open water and shallow emergent vegetated sections, which include bulrush, cattail and other wetland native plant species. Effluent from the two wetlands is joined into a single pipe that flows by gravity back to the main outfall pipe prior to the discharge to Trifolium Drain No. 6 at Discharge Point 001 (see table on cover page).

The Facility also includes sludge drying beds and a septage receiving area.

Wastewater is discharged from Discharge Point 001 to the Trifolium Drain No. 6, which eventually discharges into the New River, a water of the United States, about 8 miles from the Salton Sea, within the Colorado River Basin. Attachment B provides a map of the area around the facility. Attachment C provides a flow schematic of the facility.

- C. Legal Authorities.** This Order is issued pursuant to Section 402 of the Federal Clean Water Act (CWA) and implementing regulations adopted by the U.S. Environmental Protection Agency (USEPA) and Chapter 5.5, Division 7 of the California Water Code (CWC) (commencing with Section 13370). It shall serve as an NPDES permit for point source discharges from this facility to surface waters. This Order also serves as WDRs pursuant to Article 4, Chapter 4, Division 7 of the CWC (commencing with Section 13260).

- D. Background and Rationale for Requirements.** The Regional Water Board developed the requirements in this Order based on information submitted as part of the application, through MRPs, and other available information. The Fact Sheet (Attachment F), which contains background information and rationale for Order requirements, is hereby incorporated into this Order and constitutes part of the Findings for this Order. Attachments A through E and G through I are also incorporated into this Order.
- E. California Environmental Quality Act (CEQA).** Under CWC Section 13389, this action to adopt an NPDES permit is exempt from the provisions of Chapter 3 of CEQA, commencing with Section 21100 of the Public Resources Code.
- F. Technology-Based Effluent Limitations.** Section 301(b) of the CWA and implementing USEPA permit regulations at Section 122.44, Title 40 of the Code of Federal Regulations (CFR¹), require that permits include conditions meeting applicable technology-based requirements at a minimum, and any more stringent effluent limitations necessary to meet applicable water quality standards. The discharge authorized by this Order must meet minimum federal technology-based requirements based on Secondary Treatment Standards at Part 133 and Best Professional Judgment (BPJ) in accordance with Part 125, Section 125.3. A detailed discussion of the technology-based effluent limitations development is included in the Fact Sheet.
- G. Water Quality-Based Effluent Limitations.** Section 301(b) of the CWA and Section 122.44(d) require that permits include limitations more stringent than applicable federal technology-based requirements where necessary to achieve applicable water quality standards.

Section 122.44(d)(1)(i) mandates that permits include effluent limitations for all pollutants that are or may be discharged at levels that have the reasonable potential to cause or contribute to an exceedance of a water quality standard, including numeric and narrative objectives within a standard. Where reasonable potential has been established for a pollutant, but there is no numeric criterion or objective for the pollutant, water quality-based effluent limitations (WQBELs) must be established using: (1) USEPA criteria guidance under CWA Section 304(a), supplemented where necessary by other relevant information; (2) an indicator parameter for the pollutant of concern; or (3) a calculated numeric water quality criterion, such as a proposed state criterion or policy interpreting the state's narrative criterion, supplemented with other relevant information, as provided in Section 122.44(d)(1)(vi).

- H. Water Quality Control Plans.** The Regional Water Board adopted a Water Quality Control Plan for the Colorado River Basin (hereinafter Basin Plan) on November 17, 1993, that designates beneficial uses, establishes water quality objectives, and contains implementation programs and policies to achieve those objectives for all waters addressed through the plan (includes amendments adopted by the Regional Water Board to date). In addition, the Basin Plan implements State Water Resources Control Board (State Water Board) Resolution No. 88-63, which established state policy that all waters, with certain exceptions, should be considered suitable or potentially suitable for municipal or domestic supply. This exception does not apply because the beneficial uses of the receiving water are not designated as such. Beneficial uses applicable to the Trifolium Drain No. 6 are summarized in Table 5 as follows:

¹ All further statutory references are to title 40 of the CFR unless otherwise indicated.

Table 5. Basin Plan Beneficial Uses

Discharge Point	Receiving Water Name	Beneficial Use(s)
001	Trifolium Drain No. 6 (Imperial Valley Drains)	<u>Existing:</u> Freshwater Replenishment (FRSH); Contact (REC-1) ^{1, 2} and Non-Contact (REC-2) ¹ Water Recreation; Warm Freshwater Habitat (WARM); Wildlife Habitat (WILD); Preservation or Rare, Threatened or Endangered Species (RARE) ³ .

¹ Unauthorized Use.

² The only REC-1 usage that is known to occur is from infrequent fishing activity.

³ Rare, endangered, or threatened wildlife exists in or utilizes some of this waterway(s). If the RARE beneficial use may be affected by a water quality control decision, responsibility for substantiation of the existence of rare, endangered, or threatened species on a case-by-case basis is upon the California Department of Fish and Game on its own initiative and/or at the request of the Regional Water Board; and such substantiation must be provided within a reasonable time frame as approved by the Regional Water Board.

Requirements of this Order implement the Basin Plan.

The immediate receiving water is the Trifolium Drain No. 6, which is a part of the Imperial Valley Drains. The 2006 USEPA 303(d) list of impaired waters (hereinafter 303(d) List) classifies the Imperial Valley Drains as impaired by sediment/silt, pesticides, dieldrin, DDT, endosulfan, PCBs, toxaphene and selenium. A sedimentation/siltation Total Maximum Daily Load (TMDL) for the Imperial Valley Drains has been approved by U.S. Environmental Protection Agency (USEPA). The sedimentation/siltation TMDL has established a WLA for sediment. The established Total Suspended Solids effluent limitations in this Order comply with the WLA for sediment established in the Imperial Valley Drains sedimentation/siltation TMDL. Further, the New River, to which the Trifolium Drain No. 6 is tributary, is listed as impaired by 1,2,4-trimethylbenzene, chlordane, chloroform, chlorpyrifos, DDT, diazinon, dieldrin, mercury, meta-para xylenes, nutrients, dissolved oxygen, o-xylenes, PCBs, p-cymene, p-dichlorobenzene, pesticides, selenium, toluene, toxaphene, toxicity, copper and trash. A pathogen and sedimentation/siltation TMDL have been approved by USEPA for the New River and are implemented in this Order. The pathogen and sedimentation/siltation TMDL's established WLA's for fecal coliform, *E. Coli*, enterococci and sediment. The established fecal coliform, *E. Coli*, enterococci and total suspended solids effluent limitations in this Order comply with the WLA's established in the New River pathogen and sedimentation/siltation TMDLs. Further, there are two TMDLs under development for dissolved oxygen and VOCs for the New River. A Trash TMDL for the New River has been approved by the Regional Water Board and State Water Board and is in the process of being approved by the Office of Administrative Law and the USEPA. In addition, the 303(d) List classifies the Salton Sea as impaired by nutrients, salt and selenium. Tributaries to the Salton Sea, including the New River, may be affected by the development of TMDLs for the New River. No TMDL has been developed to date for the Salton Sea, although a nutrient TMDL is under development for the Salton Sea that may impact the permitted discharges to tributaries to the Salton Sea (New River). The nutrient TMDL for the Salton Sea is tentatively scheduled for completion in 2009.

The State Water Board adopted the *Water Quality Control Plan for Control of Temperature in the Coastal and Interstate Waters and Enclosed Bays and Estuaries of California* (Thermal Plan) on May 18, 1972, and amended this plan on September 18, 1975. This plan contains temperature objectives for surface waters. The Thermal Plan does not apply to the Trifolium Drain No. 6.

- I. National Toxics Rule (NTR) and California Toxics Rule (CTR).** USEPA adopted the NTR on December 22, 1992, and later amended it on May 4, 1995 and November 9, 1999. About forty criteria in the NTR applied in California. On May 18, 2000, USEPA adopted the CTR. The CTR promulgated new toxics criteria for California and, in addition, incorporated the previously adopted NTR criteria that were applicable in the state. The CTR was amended on February 13, 2001. These rules contain water quality criteria for priority pollutants.
- J. State Implementation Policy.** On March 2, 2000, the State Water Board adopted the *Policy for Implementation of Toxics Standards for Inland Surface Waters, Enclosed Bays, and Estuaries of California* (State Implementation Policy or SIP). The SIP became effective on April 28, 2000 with respect to the priority pollutant criteria promulgated for California by the USEPA through the NTR and to the priority pollutant objectives established by the Regional Water Board in the Basin Plan. The SIP became effective on May 18, 2000 with respect to the priority pollutant criteria promulgated by the USEPA through the CTR. The State Water Board adopted amendments to the SIP on February 24, 2005 that became effective on July 13, 2005. The SIP establishes implementation provisions for priority pollutant criteria and objectives and provisions for chronic toxicity control. Requirements of this Order implement the SIP.
- K. Compliance Schedules and Interim Requirements.** Section 2.1 of the SIP provides that, based on a Discharger's request and demonstration that it is infeasible for an existing Discharger to achieve immediate compliance with an effluent limitation derived from a CTR criterion, compliance schedules may be allowed in an NPDES permit. Unless an exception has been granted under section 5.3 of the SIP, a compliance schedule may not exceed 5 years from the date that the permit is issued or reissued, nor may it extend beyond 10 years from the effective date of the SIP (or May 18, 2010) to establish and comply with CTR criterion-based effluent limitations. Where a compliance schedule for a final effluent limitation exceeds 1 year, the Order must include interim numeric limitations for that constituent or parameter. Where allowed by the Colorado River Basin Water Quality Control Plan, compliance schedules and interim effluent limitations or discharge specifications may also be granted to allow time to implement a new or revised water quality objective. This Order includes compliance schedules and interim effluent limitations and discharge specifications. A detailed discussion of the basis for the compliance schedule(s) and interim effluent limitation(s) and discharge specifications is included in the Fact Sheet.
- L. Alaska Rule.** On March 30, 2000, USEPA revised its regulation that specifies when new and revised state and tribal water quality standards (WQS) become effective for CWA purposes. (40 C.F.R. § 131.21; 65 Fed. Reg. 24641 (April 27, 2000).) Under the revised regulation (also known as the Alaska rule), new and revised standards submitted to USEPA after May 30, 2000, must be approved by USEPA before being used for CWA purposes. The final rule also provides that standards already in effect and submitted to USEPA by May 30, 2000 may be used for CWA purposes, whether or not approved by USEPA.
- M. Stringency of Requirements for Individual Pollutants.** This Order contains both technology-based and water quality-based effluent limitations for individual pollutants. The technology-based effluent limitations consist of restrictions on biochemical oxygen demand (BOD₅), total suspended solids (TSS), pH and percent removal of BOD₅ and TSS. Restrictions on BOD₅, TSS, pH and percent removal of BOD₅ and TSS are discussed in IV.B.2 in the Fact Sheet. This Order's technology-based pollutant restrictions implement the minimum, applicable federal technology-based requirements. These limitations are not more stringent than required by the CWA.

Water quality-based effluent limitations have been scientifically derived to implement water quality objectives that protect beneficial uses. Both the beneficial uses and the water quality objectives have been approved pursuant to federal law and are the applicable federal water quality standards. To the extent that toxic pollutant water quality-based effluent limitations were derived from the CTR, the CTR is the applicable standard pursuant to Section 131.38. The scientific procedures for calculating the individual water quality-based effluent limitations for priority pollutants are based on the CTR-SIP, which was approved by USEPA on May 18, 2000. All beneficial uses and water quality objectives contained in the Basin Plan were approved under state law and submitted to and approved by USEPA prior to May 30, 2000. Any water quality objectives and beneficial uses submitted to USEPA prior to May 30, 2000, but not approved by USEPA before that date, are nonetheless “applicable water quality standards for purposes of the CWA” pursuant to Section 131.21(c)(1). Collectively, this Order’s restrictions on individual pollutants are no more stringent than required to implement the requirements of the CWA.

- N. Anti-degradation Policy.** Section 131.12 requires that the state water quality standards include an anti-degradation policy consistent with the federal policy. The State Water Board established California’s anti-degradation policy in State Water Board Resolution No. 68-16. Resolution No. 68-16 incorporates the federal anti-degradation policy where the federal policy applies under federal law. Resolution No. 68-16 requires that existing quality of waters be maintained unless degradation is justified based on specific findings. The Regional Water Board’s Basin Plan implements, and incorporates by reference, both the state and federal anti-degradation policies. As discussed in detail in Fact Sheet section III.C.10, the permitted discharge is consistent with the anti-degradation provision of Section 131.12 and State Water Board Resolution No. 68-16.
- O. Anti-Backsliding Requirements.** Sections 402(o)(2) and 303(d)(4) of the CWA and federal regulations at Title 40, CFR, Section 122.44(l) prohibit backsliding in NPDES permits. These anti-backsliding provisions require effluent limitations in a reissued permit to be as stringent as those in the previous permit, with some exceptions where limitations may be relaxed. Some effluent limitations in this Order are less stringent than those in the previous Order. Numeric effluent limitations for total dissolved solids have been replaced by a narrative limitation. As discussed in detail the Fact Sheet, this relaxation of effluent limitations is consistent with the anti-backsliding requirements of the CWA and federal regulations.
- P. Endangered Species Act.** This Order does not authorize any act that results in the taking of a threatened or endangered species or any act this is now prohibited, or becomes prohibited in the future, under either the California Endangered Species Act (Fish and Game Code Sections 2050 to 2097) or the Federal Endangered Species Act (16 U.S.C.A. Sections 1531 to 1544). This Order requires compliance with effluent limits, receiving water limits, and other requirements to protect beneficial uses of waters of the state. The discharger is responsible for meeting all requirements of the applicable Endangered Species Act.
- Q. Monitoring and Reporting.** Section 122.48 requires that all NPDES permits specify requirements for recording and reporting monitoring results. CWC Sections 13267 and 13383 authorize the Regional Water Board to require technical and monitoring reports. The MRP establishes monitoring and reporting requirements to implement federal and state requirements. This MRP is provided in Attachment E.

- R. Standard and Special Provisions.** Standard Provisions, which apply to all NPDES permits in accordance with Section 122.41, and additional conditions applicable to specified categories of permits in accordance with Section 122.42, are provided in Attachment D. The Discharger must comply with all standard provisions and with those additional conditions that are applicable under Section 122.42. The Regional Water Board has also included in this Order special provisions applicable to the Discharger. A rationale for the special provisions contained in this Order is provided in the attached Fact Sheet.
- S. Provisions and Requirements Implementing State Law.** The provisions and requirements in subsection V.B and VI.C.4 of this Order are included to implement state law only. These provisions and requirements are not required or authorized under the federal CWA; consequently, violations of these provisions and requirements are not subject to the enforcement remedies that are available for NPDES violations.
- T. Notification of Interested Parties.** The Regional Water Board has notified the Discharger and interested agencies and persons of its intent to prescribe WDRs for the discharge and has provided them with an opportunity to submit their written comments and recommendations. Details of notification are provided in the Fact Sheet of this Order.
- U. Consideration of Public Comment.** The Regional Water Board, in a public meeting, heard and considered all comments pertaining to the discharge. Details of the Public Hearing are provided in the Fact Sheet of this Order.

III. DISCHARGE PROHIBITIONS

- A.** Bypass, overflow, discharge or spill of untreated or partially treated waste is prohibited.
- B.** The discharge of waste to land not owned or controlled by the Discharger is prohibited.
- C.** Discharge of treated wastewater at a location or in a manner different from that described in Findings of this Order is prohibited.
- D.** Except as allowed under the Standard Provisions for NPDES permits (hereinafter Standard Provisions), included as Attachment D, the bypass or overflow of untreated wastewater or wastes to the Trifolium Drain No. 6 is prohibited.
- E.** The Discharger shall not accept waste in excess of the design treatment capacity of the disposal system.
- F.** The discharge shall not cause degradation of any water supply.
- G.** The treatment or disposal of wastes from the facility shall not cause pollution or nuisance as defined in Section 13050, subdivisions (l) and (m), respectively, of the CWC.

IV. EFFLUENT LIMITATIONS AND DISCHARGE SPECIFICATIONS

A. Effluent Limitations – Discharge Point 001

1. Final Effluent Limitations – Discharge Point 001

a. The Discharger shall maintain compliance with the following effluent limitations at Discharge Point 001, with compliance measured at Monitoring Location EFF-001 as described in the attached MRP:

Table 6. Effluent Limitations

Parameter	Units	Effluent Limitations				
		Average Monthly	Average Weekly	Maximum Daily	Instantaneous Minimum	Instantaneous Maximum
Flow	MGD	0.50	---	---	---	---
Chlorine, Total Residual	mg/L	0.01	---	---	---	0.02
	lbs/day ¹	0.04	---	---	---	0.08
pH	pH units	---	---	---	6.0	9.0
Biochemical Oxygen Demand (BOD) (5-day @ 20 Deg. C)	mg/L	30	45	---	---	---
	lbs/day ¹	130	190	---	---	---
Copper, Total Recoverable ²	µg/L	2.9	---	5.8	---	---
	lbs/day ¹	0.012	---	0.024	---	---
Total Suspended Solids (TSS)	mg/L	30	45	---	---	---
	lbs/day ¹	130	190	---	---	---
Selenium, Total Recoverable	µg/L	4.1	---	8.2	---	---
	lbs/day ¹	0.017	---	0.034	---	---

¹ The mass-based effluent limitations are based on a design capacity of 0.50 MGD.

² The effluent limitations for Copper are applicable on May 18, 2010 provided the Discharger submits an Infeasibility Report for copper to the Regional Water Board by October 19, 2007.

b. **Percent Removal:** The average monthly percent removal of BOD 5-day @ 20°C and total suspended solids shall not be less than less than 85 percent.

c. **Toxicity:** There shall be no acute or chronic toxicity in the treatment plant effluent nor shall the treatment plant effluent cause any acute or chronic toxicity in the receiving water, as defined in Section V.C of the MRP. All waters shall be maintained free of toxic substances in concentrations which are toxic to, or which produce detrimental physiological responses in human, plant, animal, or indigenous aquatic life. Compliance with this objective will be determined by use of indicator organisms, analyses of species diversity, population density, growth anomalies, or bioassays of appropriate duration or other appropriate methods specified by the Regional Water Board.

- d. **Bacteria:** The bacterial concentrations in the wastewater effluent discharged to Trifolium Drain No. 6 shall not exceed the following concentrations, as measured by the following bacterial indicators:
- i. ***E. Coli.*** The geometric mean bacterial density (based on a minimum of not less than five samples equally spaced over a 30-day period) shall not exceed a Most Probable Number (MPN) of 126 MPN per 100 milliliters, nor shall any sample exceed the maximum allowable bacterial density of 400 MPN per 100 milliliters.
 - ii. **Enterococci.** The geometric mean bacterial density (based on a minimum of not less than five samples equally spaced over a 30-day period) shall not exceed a Most Probable Number (MPN) of 33 MPN per 100 milliliters, nor shall any sample exceed the maximum allowable bacterial density of 100 MPN per 100 milliliters.
 - iii. **Fecal Coliform.** The geometric mean bacterial density (based on a minimum of not less than five samples equally spaced over a 30-day period) shall not exceed a Most Probable Number (MPN) of 200 MPN per 100 milliliters, nor shall more than ten percent of the total samples during any 30-day period exceed 400 MPN per 100 milliliters.
- e. **Total Dissolved Solids:** Discharges of wastes or wastewater shall not increase the total dissolved solids content of receiving waters, unless it can be demonstrated to the satisfaction of the Regional Water Board that such an increase in total dissolved solids does not adversely affect beneficial uses of receiving waters.

2. Interim Effluent Limitations

- a. From September 19, 2007 to May 18, 2010, the Discharger shall maintain compliance with the following limitations at Discharge Point 001, with compliance measured at Monitoring Location EFF-001 as described in the attached MRP. These interim effluent limitations shall apply in lieu of the corresponding final effluent limitations specified for the same parameters during the time period indicated in this provision.

Table 7. Interim Effluent Limitations

Parameter	Units	Effluent Limitations			
		Average Monthly	Maximum Daily	Instantaneous Minimum	Instantaneous Maximum
Copper, Total Recoverable ¹	µg/L	7.9	7.9	---	---
	lbs/day ²	0.033	0.033	---	---

¹ In accordance with Special Provision VI.C.2.b of this Order, the Discharger shall submit a Copper Infeasibility Report by October 19, 2007 for the Interim Effluent Limitations described in Section IV.A.2 for copper to remain effective. If the Regional Water Board has not received the Copper Infeasibility Report by October 19, 2007, the final effluent limitations for copper specified in Section IV.A.1.a become effective on October 19, 2007.

² The mass-based effluent limitation is based on a design capacity of 0.50 MGD.

B. Land Discharge Specifications – Not Applicable

C. Reclamation Specifications – Not Applicable

V. RECEIVING WATER LIMITATIONS

A. Surface Water Limitations

Receiving water limitations are based on water quality objectives contained in the Basin Plan and are a required part of this Order. The discharge shall not cause the following in Trifolium Drain No. 6:

1. Result in the concentration of dissolved oxygen in the receiving water to fall below 5.0 mg/L. When dissolved oxygen in the receiving water is already below 5.0 mg/L, the discharge shall not cause any further depression.
2. Result in the presence of oil, grease, floating material (liquids, solids, foam and scum) or suspended material in amounts that create a nuisance or adversely affect beneficial uses.
3. Result in the deposition of pesticides or combination of pesticides detectable in concentrations that adversely affect beneficial uses.
4. Result in discoloration in the receiving water that adversely affects beneficial uses.
5. Result in the discharge of biostimulatory substances in concentrations that promote aquatic growths to the extent that such growths cause nuisance or adversely affect beneficial uses.
6. Results in an increase in turbidity that adversely affects the beneficial uses.
7. Result in the normal ambient pH of the receiving water to fall below 6.0 or exceed 9.0 units.
8. Result in the natural receiving water temperature to be altered, unless it can be demonstrated to the satisfaction of the Regional Water Board that such alteration in temperature does not adversely affect beneficial uses.
9. Result in the deposition of material that causes nuisance or adversely affects beneficial uses.
10. Result in the discharge of an individual chemical or combination of chemicals in concentrations that adversely affect beneficial uses.
11. Result in toxic pollutants to be present in the water column, sediments or biota in concentrations that adversely affect beneficial uses or that produce detrimental physiological responses in human, plant, animal, or aquatic life.
12. Result in an increase in taste or odor-producing substances that adversely affect beneficial uses.
13. Result in the violation of any applicable water quality standard for receiving waters adopted by the Regional Water Board or the State Water Board as required by the Federal CWA and regulations adopted thereunder. If more stringent applicable water quality standards are promulgated or approved pursuant to CWA Section 303 or amendments thereto, the Regional Water Board will revise and modify this Permit in accordance with such more stringent standards.

14. Result in the concentration of total dissolved solids in Trifolium Drain No. 6 to exceed an annual average concentration of 4,000 mg/L or an instantaneous maximum concentration of 4,500 mg/L.

B. Groundwater Limitations – Not Applicable

VI. PROVISIONS

A. Standard Provisions

1. **Federal Standard Provisions.** The Discharger shall comply with all Standard Provisions included in Attachment D of this Order.
2. **Regional Water Board Standard Provisions.** The Discharger shall comply with the following provisions:
 - a. The POTW shall be protected from any washout or erosion of wastes or covering material, and from any inundation, which could occur as a result of floods having a predicted frequency of once in 100 years.
 - b. The Discharger shall comply with all conditions of this Order. Noncompliance constitutes a violation of the Federal Clean Water Act and Porter-Cologne Water Quality Control Act, and is grounds for enforcement action; for permit termination, revocation and reissuance, or modification of WDRs; or denial of a permit renewal application.
 - c. The Discharger shall ensure that all site-operating personnel are familiar with the content of this Order, and shall maintain a copy of this Order at the site.
 - d. The Discharger's wastewater treatment plant shall be supervised and operated by persons possessing certification of appropriate grade pursuant to Section 3680, Chapter 26, Division 3, Title 23 of the California Code of Regulations (CCRs). The Discharger shall ensure that all operating personnel are familiar with the contents of this Order.
 - e. The Discharger shall immediately notify the Regional Water Board by phone at (760) 346-7491 and the Office of Emergency Services by phone at (800) 852-7550 to report any noncompliance that may endanger human health or the environment as soon as: (1) the Discharger has knowledge of the discharge; (2) notification is possible; and (3) notification can be provided without substantially impeding cleanup or other emergency measures. During non-business hours, the Discharger shall leave a voice message on the Regional Water Board's voice recorder. A written report shall also be provided within five (5) business days of the time the Discharger becomes aware of the incident. The written report shall contain a description of the noncompliance and its cause, the period of noncompliance, the anticipated time to achieve full compliance, and the steps taken or planned, to reduce, eliminate, and prevent recurrence of the noncompliance. The Discharger shall report all intentional or unintentional spills in excess of one thousand (1,000) gallons occurring within the facility or collection system to the Regional Water Board in accordance with the above time limits.
 - f. The Discharger shall provide a report to the Regional Water Board upon determining that the treatment plant's monthly average flow rate for any month exceeds 80 percent of the design treatment or disposal capacity. The report should indicate what steps, if any the Discharger intends to take to provide for the expected wastewater treatment capacity necessary when the plant reaches design capacity.

- g. Prior to any change in ownership or management of this operation, the Discharger shall transmit a copy of this Order to the succeeding owner/operator, and forward a copy of the transmittal letter to the Regional Water Board.
- h. Prior to any modifications in this facility, which would result in material change in the quality or, quantity of wastewater treated or discharged, or any material change in the location of discharge, the Discharger shall report all pertinent information in writing to the Regional Water Board and obtain revised requirements before any modifications are implemented.
- i. Adequate measures shall be taken to assure that flood or surface drainage waters do not erode or otherwise render portions of the discharge facilities inoperable.
- j. This Order does not authorize violation of any federal, state, or local laws or regulations.

B. Monitoring and Reporting Program (MRP) Requirements

The Discharger shall comply with the MRP requirements, and future revisions thereto, in Attachment E of this Order.

C. Special Provisions

1. Reopener Provisions

- a. This Order may be reopened for modification, or revocation and reissuance, as a result of the detection of a reportable priority pollutant generated by special conditions included in this Order. These special conditions may include, but are not limited to, fish tissue sampling, whole effluent toxicity, monitoring requirements on internal waste stream(s), and monitoring for surrogate parameters. Additional requirements may be included in this Order as a result of the special condition monitoring data.
- b. The Discharger shall submit data sufficient to determine if a WQBEL is required in the discharge permit as required under the SIP. It is the Discharger's responsibility to provide all information requested by the Regional Water Board for use in the analysis. The permit shall be reopened to establish WQBELs, if necessary.
- c. This Order may be modified, rescinded and reissued, for cause. The filing of a request by the Discharger for an Order modification, rescission and reissuance, or a notification of planned changes or anticipated noncompliance does not stay any Order condition. Causes for modification include the promulgation of new regulations, modification of land application plans, or modification in sludge use or disposal practices, or adoption of new regulations by the State Water Board or the Regional Water Board, including revisions to the Basin Plan.
- d. The Clean Water Act requires the Regional Water Board to modify, or terminate and reissue, the NPDES permit if a discharger must implement a pretreatment program. Public notice and a comment period are mandatory for these actions.

- e. This Order may be reopened and the Whole Effluent Toxicity (WET) Testing Requirements, contained in Section V of the MRP may be modified to address changes to USEPA or State Water Board policies or guidance regarding the testing or reporting requirements for WET testing.
- f. TMDLs for nutrients, dissolved oxygen, VOCs and trash as to be developed by the Regional Water Board. The permit may be reopened and modified to include appropriate requirements necessary to fully implement the approved TMDL, if needed.

2. Special Studies, Technical Reports and Additional Monitoring Requirements

- a. **Copper Infeasibility Report.** The Discharger shall submit to the Regional Water Board a Copper Infeasibility Report within 30 days of the effective date of this Order. If the Regional Water Board has not received the Copper Infeasibility Report by October 19, 2007, the final effluent limitations for copper, specified in Effluent Limitations, IV.A.1.a. of this Order are effective. The Copper Infeasibility Report shall provide:
 - i. Documentation that diligent efforts have been made to quantify pollutant levels in the discharge and the sources of the pollutant in the waste stream, and the results of those efforts;
 - ii. Documentation of source control and/or pollution minimization efforts currently underway or completed;
 - iii. A proposed schedule for additional or future source control measures, pollutant minimization actions, or waste treatment (i.e., facility upgrades); and
 - iv. A demonstration that the proposed schedule is as short as practicable.
- b. **Priority Pollutant Monitoring.** Within 90 days of the effective date of this Order, the Discharger shall submit to the Regional Water Board results of at least one upstream receiving water and effluent sampling event, for monitoring locations RSW-001 and EFF-001, respectively, analyzed for priority pollutants contained in the CTR. The Discharger shall ensure the analytical methods used for the analysis of the priority pollutants and the applicable Minimum Levels (MLs) reported for each priority pollutant comply with the analytical methods and minimum levels established in Appendix 4 of the SIP. The Discharger shall also comply with the monitoring and reporting requirements established in Sections 2.3 and 2.4 of the SIP. Attachment I provides the MLs for use in reporting and compliance determination purposes in accordance with Appendix 4 of the SIP
- c. **Toxicity Identification Evaluations or Toxicity Reduction Evaluations.** The Discharger shall submit to the Regional Water Board a toxicity reduction evaluation (TRE) workplan (1-2 pages) within 90 days of the effective date of this Order. This plan shall describe the steps the Discharger intends to follow in the event that toxicity is detected, and should include at a minimum.
 - i. A description of the investigation and evaluation techniques that will be used to identify potential causes/sources of toxicity, effluent variability, and treatment system efficiency;

- ii. A description of the facility's method of maximizing in-house treatment efficiency and good housekeeping practices, and a list of all chemicals used in operation of the facility;
 - iii. If a toxicity identification evaluation (TIE) is necessary, who will conduct it (i.e., in-house or outside consultant).
- d. **Translator Study.** Should the Discharger request to use a translator for metals and selenium different than the USEPA conversion factor, it shall complete a translator study within 2 years from the date of the issuance of this permit as stated in the SIP. In the event a translator study is not completed within the specified time, the USEPA conversion factor-based water quality standard as specified in the CTR shall be effective as a default standard.
- e. **Total Dissolved Solids Study.** The Discharger shall perform a study to evaluate whether a 400 mg/L incremental increase in salinity above the source water is practical and if not, what incremental increase is practical for its discharge. This report shall be submitted to the Regional Water Board's Executive Officer prior to the filing date for re-application. The following items describe the purpose and description of the minimum requirements for the report:
- i. The permitting authority may permit a discharge in excess of the 400 mg/L incremental increase at the time of issuance or reissuance of a NPDES discharge permit, upon satisfactory demonstration by the permittee that it is not practicable to attain the 400 mg/L limit.
 - ii. Demonstration by the applicant must include information on the following factors relating to the potential discharge:
 - 1) Description of the municipal entity and facilities.
 - 2) Description of the quantity and salinity of various waste streams into the collection system and contributing to total dissolved solids (TDS) of the discharge.
 - 3) Description of significant salt sources of the municipal wastewater collection system, and identification of entities responsible for each source, if available.
 - 4) Description of water rights, including diversions and consumptive use quantities.
 - 5) Description of the wastewater discharge, receiving waters, quantity, salt load, and salinity.
 - 6) Alternative plans for minimizing salt contribution from the various sources affecting the TDS of the discharge. Alternative plans should include:
 - (1) Description of system salt sources and alternative means of control; and
 - (2) Cost of alternative plans in dollars per ton, of salt removed from discharge.

- 7) Such other information pertinent to demonstration of non-practicability as the permitting authority may deem necessary.
- iii. In determining what permit conditions shall be required, the permit issuing authority shall consider the following criteria including, but not limited to:
 - 1) The practicability of achieving the 400 mg/L incremental increase.
 - 2) Where the 400 mg/L incremental increase is not determined to be practicable, the discharger shall provide the following:
 - (1) The impact of the proposed salt input of each alternative on the beneficial uses of the surface water in terms of tons per year and concentration;
 - (2) Costs per ton of salt removed from discharge of each alternative plan;
 - (3) Capability of minimizing the salt discharge;
 - (4) A proposed value for the practical incremental increase; and
 - (5) A justification for the proposed practical incremental increased value; including justification that it would not affect beneficial uses or that produce detrimental physiological responses in human, plant, animal, or aquatic life.

Following review of the report, this permit may be re-opened to establish an appropriate TDS effluent limit.

3. Best Management Practices and Pollution Prevention

a. Pollutant Minimization Program

The Discharger shall develop and conduct a Pollutant Minimization Program (PMP) as further described below when there is evidence (e.g., sample results reported as DNQ when the effluent limitation is less than the MDL, sample results from analytical methods more sensitive than those methods required by this Order, presence of whole effluent toxicity, health advisories for fish consumption, results of benthic or aquatic organism tissue sampling) that a priority pollutant is present in the effluent above an effluent limitation and either:

- i. A sample result is reported as DNQ and the effluent limitation is less than the RL; or
- ii. A sample result is reported as ND and the effluent limitation is less than the MDL, using definitions described in Attachment A and reporting protocols described in MRP section X.B.4.

The PMP shall include, but not be limited to, the following actions and submittals acceptable to the Regional Water Board:

- i. An annual review and semi-annual monitoring of potential sources of the reportable priority pollutant(s), which may include fish tissue monitoring and other bio-uptake sampling;

- ii. Quarterly monitoring for the reportable priority pollutant(s) in the influent to the wastewater treatment system;
- iii. Submittal of a control strategy designed to proceed toward the goal of maintaining concentrations of the reportable priority pollutant(s) in the effluent at or below the effluent limitation;
- iv. Implementation of appropriate cost-effective control measures for the reportable priority pollutant(s), consistent with the control strategy; and
- v. An annual status report that shall be sent to the Regional Water Board including:
 - 1) All PMP monitoring results for the previous year;
 - 2) A list of potential sources of the reportable priority pollutant(s);
 - 3) A summary of all actions undertaken pursuant to the control strategy; and
 - 4) A description of actions to be taken in the following year.

b. Storm Water

- i. In the event that there are storm water discharges associated with industrial activities, the Discharger shall submit a Notice of Intent and/or maintain coverage under the General Storm Water Permit.
 - 1) All storm water discharges from this Facility must comply with the lawful requirements of municipalities, counties, drainage districts, and other local agencies, regarding discharges of storm water to storm water drain systems or other courses under their jurisdiction.
 - 2) Storm water discharges from the Facility shall not cause or threaten to cause pollution or contamination.
 - 3) Storm water discharges from the Facility shall not contain hazardous substances equal to or in excess of a reportable quantity listed in 40 CFR Part 117 and/or 40 CFR Part 302.

4. Construction, Operation and Maintenance Specifications

a. Facility and Treatment Operation

- i. The Discharger shall, at all times, properly operate and maintain all systems and components of collection, treatment and control which are installed or used by the Discharger to achieve compliance with the conditions of this Order. Proper operation and maintenance includes effective performance, adequate process controls and appropriate quality assurance procedures. This provision requires the operation of backup or auxiliary facilities or similar systems when necessary to achieve compliance with the conditions of this Order. All systems both in service and reserved, shall be inspected and maintained on a regular basis. Records shall be kept of the inspection results and maintenance performed and made available to the Regional Water Board upon demand.

- ii. Temporary power shall be provided to maintain the plant in operation in the event of commercial power failure.
- iii. Adequate measures shall be taken to assure that unauthorized persons are effectively excluded from contact with the wastewater disposal facilities.
- iv. The Discharger shall implement acceptable operation and maintenance at the facility so that needed repair and maintenance are performed in a timely manner.

b. Spill Response Plan

- i. The Discharger shall review its current Spill Response Plan (SRP) developed under previous Order No. R7-2002-0004 and revise if needed within 60 days after the effective date of this Order. Revised plans shall be submitted for Regional Water Board staff review. Thereafter, the plan shall be updated annually, and shall be available for staff review during Regional Water Board inspections. The Discharger shall ensure that all operating personnel are familiar with the contents of the SRP. A copy of the SRP shall be maintained at the site and shall be accessible to all operating personnel.

5. Special Provisions for Municipal Facilities (POTWs Only)

a. Sludge Disposal Requirements

- i. The Discharger shall provide a plan as to the method, treatment, handling and disposal of sludge that is consistent with all state and federal laws and regulations and obtain prior written approval from the Regional Water Board specifying location and method of disposal, before disposing of treated or untreated sludge, or similar solid waste materials using an alternative method than that described in the Findings of the Order.
- ii. The Discharger shall maintain a permanent log of all solids hauled away from the treatment facility for use/disposal elsewhere and shall provide a summary of the volume, type (screenings, grit, raw sludge, digested sludge), use (agricultural, composting, etc.), and the destination in accordance with the MRP of this Order. The sludge that is stockpiled at the treatment facility shall be sampled and analyzed for those constituents listed in the sludge monitoring section of the MRP of this Order and as required by Part 503. The results of the analyses should be submitted to the Regional Water Board as part of the MRP.
- iii. All sludge generated at the wastewater treatment plant will be disposed, treated, or applied to land in accordance with Part 503.
- iv. Collected screenings, sludge, and other solids removed from liquid wastes shall be disposed of in a manner that is consistent with State Water Resources Control Board and Integrated Waste Management Board's joint regulations in Title 27 of the CCRs and that is approved by the Regional Water Board's Executive Officer.

b. Pretreatment

- i In the event that (i) the facility has a treatment capacity greater than 5 MGD and Industrial Users [40 CFR §403.3(h) are discharging pollutants which Pass Through [40 CFR §403.3(n)] or Interfere [40 CFR §403.3(i)] with the operation of the wastewater treatment facility or are otherwise subject to National Pretreatment Standards [40 CFR §403.3(j)], (ii) Cal. Code of Regs, Section 2233 of Title 23 requires the facility to have and enforce an adequate pretreatment program, or (iii) the Regional Water Board or its Executive Officer determines that other circumstances warrant in order to prevent Interference with the wastewater treatment facility or Pass Through, then:
 - 1) The Discharger shall be responsible for the compliance with all pretreatment requirements contained in CWA Part 403, and shall be subject to enforcement actions, penalties, and other remedies by the USEPA, or the Regional Water Board, as provided in the Federal Clean Water Act, as amended (33 USC 1251 et. seq.) (hereafter “Act”).
 - 2) Within 365 days of the significant industrial wastewaters being discharged to the wastewater treatment plant, the Discharger shall seek a formal approval of its Pretreatment Plan from the Regional Water Board.
 - 3) The Discharger must seek approval of its Pretreatment Program from the Regional Water Board subject to Provision VI.C.1.d of this Order in the event a Pretreatment Program is developed.

c. Collection Systems

- i The Discharger’s collection system is part of the system that is subject to this Order. As such, the Discharger must properly operate and maintain its collection system (40 C.F.R. § 122.41(e)). The Discharger must report any non-compliance (40 C.F.R. § 122.41(l)(6) and (7)) and mitigate any discharge from the collection system in violation of this Order (40 C.F.R. § 122.41(d)). See the Order at Standard Provision VI.A. and Attachment D, subsections I.C, I.D, V.E, and V.H.

6. Other Special Provisions

- a. The Discharger may be required to submit technical reports as directed by the Regional Water Board’s Executive Officer.
- b. The Discharger shall exclude from the wastewater treatment plant any liquid or solid waste that could adversely affect the plant operation or effluent quality. The excluded liquid or solid waste shall be disposed of in accordance with applicable regulations.

7. Compliance Schedules

- a. **Compliance Plan.** The Discharger shall implement a compliance plan, to be submitted to the Regional Water Board within one year of the effective date of this Order. The Compliance Plan shall identify the measures that will be taken to achieve compliance with the permit limitations specified in Effluent Limitations, IV.A.1.a. of this Order.

- b. **Compliance Plan Annual Reports.** The Discharger shall submit annual progress reports to describe the progress of studies and or actions undertaken to achieve compliance with the limitations in this Order by the deadline specified in section IV.A.2.a. The Regional Water Board shall receive the first annual progress report at the same time the annual summary report is due, as required in section X.B.3 of MRP in Attachment E.
- c. **Deliverables and Due Dates.** The Discharger shall comply with the following compliance schedules as summarized in Table 8:

Table 8. Compliance Schedule

Activity	Description	Due Date
Copper Infeasibility Report	The Discharger shall submit an Infeasibility Report that requests a compliance schedule to comply with new effluent limitations for copper pursuant to the implementation of the SIP and California Toxics Rule (CTR). The Discharger shall document that efforts are being made to quantify pollutant levels; document source control and pollutant minimization efforts; propose a schedule for additional source control measures; and demonstrate that the proposed schedule is as short as possible.	Within 30 days of the effective date of this Order
Spill Response Plan	The Discharger shall review its current Spill Response Plan (SRP) developed under previous Order No. R7-2002-0004 and revise if needed.	Within 60 days of the effective date of this Order
Priority Pollutant Monitoring	Submittal of laboratory analytical results for at least one round of upstream receiving water and effluent sampling, for monitoring locations RSW-001 and EFF-001, respectively, for priority pollutants. Analytical methods and reporting levels shall comply with requirements of the SIP.	Within 90 days of the effective date of this Order
TRE Workplan	Description of steps the Discharger will take in the event toxicity is detected. The workplan should describe investigation and evaluation techniques used to identify sources of toxicity; method for maximizing in-house efficiency; and identify the party who will conduct the TIE.	Within 90 days of the effective date of this Order
Copper Compliance Plan	The Discharger shall submit Compliance Plan that identifies the measures that will be taken to achieve compliance with the permit limitations specified in Effluent Limitations, IV.A.1.a. of this Order.	Within 1 year of the effective date of the Order
TDS Study	Submit a report indicating whether a 400 mg/L increase in salinity above the source water is practical.	Prior to filing date for re-application

VII. COMPLIANCE DETERMINATION

Compliance with the effluent limitations contained in section IV of this Order will be determined as specified below:

A. General.

Compliance with effluent limitations for priority pollutants shall be determined using sample reporting protocols defined in the MRP and Attachment A of this Order. For purposes of reporting and administrative enforcement by the Regional and State Water Boards, the Discharger shall be deemed out of compliance with effluent limitations if the concentration of the priority pollutant in the monitoring sample is greater than the effluent limitation and greater than or equal to the reporting level (RL).

B. Multiple Sample Data.

When determining compliance with an AMEL or MDEL for priority pollutants and more than one sample result is available, the Discharger shall compute the arithmetic mean unless the data set contains one or more reported determinations of "Detected, but Not Quantified" (DNQ) or "Not Detected" (ND). In those cases, the Discharger shall compute the median in place of the arithmetic mean in accordance with the following procedure:

1. The data set shall be ranked from low to high, ranking the reported ND determinations lowest, DNQ determinations next, followed by quantified values (if any). The order of the individual ND or DNQ determinations is unimportant.
2. The median value of the data set shall be determined. If the data set has an odd number of data points, then the median is the middle value. If the data set has an even number of data points, then the median is the average of the two values around the middle unless one or both of the points are ND or DNQ, in which case the median value shall be the lower of the two data points where DNQ is lower than a value and ND is lower than DNQ.

C. Average Monthly Effluent Limitation (AMEL).

If the average (or when applicable, the median determined by subsection B above for multiple sample data) of daily discharges over a calendar month exceeds the AMEL for a given parameter, this will represent a single violation, although the Discharger will be considered out of compliance for each day of that month for that parameter (e.g., resulting in 31 days of non-compliance in a 31-day month). If only a single sample is taken during the calendar month and the analytical result for that sample exceeds the AMEL, the Discharger will be considered out of compliance for that calendar month. The Discharger will only be considered out of compliance for days when the discharge occurs. For any one calendar month during which no sample (daily discharge) is taken, no compliance determination can be made for that calendar month.

D. Average Weekly Effluent Limitation (AWEL).

If the average of daily discharges over a calendar week exceeds the AWEL for a given parameter, this will represent a single violation, although the Discharger will be considered out of compliance for each day of that week for that parameter, resulting in 7 days of non-compliance. If only a single sample is taken during the calendar week and the analytical result for that sample exceeds the AWEL, the Discharger will be considered out of compliance for that calendar week. The Discharger will only be considered out of compliance for days when the

discharge occurs. For any one calendar week during which no sample (daily discharge) is taken, no compliance determination can be made for that calendar week.

E. Maximum Daily Effluent Limitation (MDEL).

If a daily discharge (or when applicable, the median determined by subsection B above for multiple sample data of a daily discharge) exceeds the MDEL for a given parameter, the Discharger will be considered out of compliance for that parameter for that 1 day only within the reporting period. For any 1 day during which no sample is taken, no compliance determination can be made for that day.

F. Instantaneous Minimum Effluent Limitation.

If the analytical result of a single grab sample is lower than the instantaneous minimum effluent limitation for a parameter, the Discharger will be considered out of compliance for that parameter for that single sample. Non-compliance for each sample will be considered separately (e.g., the results of two grab samples taken within a calendar day that both are lower than the instantaneous minimum effluent limitation would result in two instances of non-compliance with the instantaneous minimum effluent limitation).

G. Instantaneous Maximum Effluent Limitation.

If the analytical result of a single grab sample is higher than the instantaneous maximum effluent limitation for a parameter, the Discharger will be considered out of compliance for that parameter for that single sample. Non-compliance for each sample will be considered separately (e.g., the results of two grab samples taken within a calendar day that both exceed the instantaneous maximum effluent limitation would result in two instances of non-compliance with the instantaneous maximum effluent limitation).

H. Effect of Conducting a Pollutant Minimization Program (PMP).

If a sample result for a priority pollutant, or the arithmetic mean or median of multiple sample results is below the RL, and there is evidence that the priority pollutant is present in the effluent above an effluent limitation and the Discharger conducts a PMP for the priority pollutant (as described in Provision VI.C.3.a.), the Discharger shall not be deemed out of compliance.

I. Water Quality-Based Effluent Limitations.

1. In accordance with Section 2.4.5 of the SIP, compliance with water quality-based effluent limitations shall be determined as follows:
 - a. Dischargers shall be deemed out of compliance with an effluent limitation if the concentration of the priority pollutant in the monitoring sample is greater than the effluent limitation and greater than or equal to the reported Minimum Level (ML).
 - b. When determining compliance with an average monthly effluent limitation and more than one sample result is available in a month, the Discharger shall compute the arithmetic mean unless the data set contains one or more reported determinations of DNQ or ND. In those cases, the Discharger shall compute the median in place of the arithmetic mean in accordance with the following procedure:

- 1) The data set shall be ranked from low to high, reported ND determinations lowest, DNQ determinations next, and followed by quantified values (if any). The order of the individual ND or DNQ determinations is unimportant.
- 2) The median value of the data set shall be determined. If the data set has an odd number of data points, then the median is the middle value. If the data set has an even number of data points, then the median is the average of the two values around the middle unless one or both of the points are ND or DNQ, in which case the median value shall be the lower of the two data points where DNQ is lower than a value and ND is lower than DNQ.

If a sample result, or the arithmetic mean or median of multiple sample results, is below the reported ML, and there is evidence that the priority pollutant is present in the effluent above an effluent limitation and the Discharger conducts a PMP, the Discharger shall not be deemed out of compliance.

J. Mass and Concentration Limitation.

Compliance with mass and concentration effluent limitations for the same parameter shall be determined separately with their respective limitations. When the concentration of a constituent in an effluent sample is determined to be ND or DNQ, the corresponding mass emission rate (MER) determined from that sample concentration shall also be reported as ND or DNQ.

K. Percent Removal.

Compliance with the equivalent to secondary treatment standard for monthly average percent removal of biochemical oxygen demand and total suspended solids, pursuant to 40 CFR Part 133, shall be determined separately for each wastewater treatment facility discharging through an outfall. For each wastewater treatment facility, the monthly average percent removal is the average of the calculated daily discharge percent removals only for days on which the constituent concentrations is monitored in both the influent and effluent of the wastewater treatment facility at locations specified in the MRP (Attachment E) within a calendar month.

The percent removal for each day shall be calculated according to the following equation:

$$\begin{aligned} &\text{Daily discharge percent removal} \\ &= ((\text{Influent concentration} - \text{Effluent concentration}) / \text{Influent Concentration}) \times 100\% \end{aligned}$$

L. Acute and Chronic Toxicity Narrative Effluent Limitations.

Compliance with whole effluent toxicity (WET) limitations established in the Order shall be determined in accordance with Section III.B of the State Water Board's Water Quality Enforcement Policy.

M. Bacteria Effluent Limitations.

Compliance with the bacterial effluent limitations established in section IV.A.1.d of this Order shall be determined as follows:

1. If the calculated geometric mean bacterial concentrations for *E. coli*, enterococi or fecal coliform exceed the 30-day geometric mean effluent limitations summarized in the Limitations and Discharge Requirements section, IV.A.1.d of this Order, this will represent a single violation of the water quality-based effluent limitation for bacteria and the Discharger will be considered out of compliance for the month in which the samples were collected.
2. If the bacterial concentrations for *E. coli* or enterococci (when both samples are collected on the same day) exceed the maximum bacterial densities summarized in the Limitations and Discharge Requirements section, IV.A.1.d of this Order, this will represent a single violation of the water quality-based effluent limitation for bacteria and the Discharger will be considered out of compliance for the day in which the samples were collected.
3. If more than ten percent of the bacterial concentrations for fecal coliform exceed 400 MPN per 100 milliliters, this will represent a single violation of the water-quality-based effluent limitation for bacteria and the Discharger will be considered out of compliance for the month in which the samples were collected.

ATTACHMENT A – DEFINITIONS

Acutely Toxic Conditions, as used in the context of mixing zones, refers to lethality that occurs to mobile aquatic organisms that move or drift through the mixing zone.

Annual Average Effluent Limitation: the highest allowable average of monthly discharges over a calendar year, calculated as the sum of all monthly discharges measured during a calendar year divided by the number of monthly discharges measured during that year.

Arithmetic Mean (μ), also called the average, is the sum of measured values divided by the number of samples. For ambient water concentrations, the arithmetic mean is calculated as follows:

$$\text{Arithmetic mean} = \mu = \Sigma x / n \quad \text{where: } \Sigma x \text{ is the sum of the measured ambient water concentrations, and } n \text{ is the number of samples.}$$

Average Monthly Effluent Limitation (AMEL): the highest allowable average of daily discharges over a calendar month, calculated as the sum of all daily discharges measured during a calendar month divided by the number of daily discharges measured during that month.

Average Weekly Effluent Limitation (AWEL): the highest allowable average of daily discharges over a calendar week (Sunday through Saturday), calculated as the sum of all daily discharges measured during a calendar week divided by the number of daily discharges measured during that week.

Best Management Practices (BMPs): BMPs are methods, measures, or practices designed and selected to reduce or eliminate the discharge of pollutants to surface waters from point and non-point discharges including storm water. BMPs include structural and non-structural controls, and operation and maintenance procedures, which can be applied before, during, and/or after pollution producing activities.

Bioaccumulative pollutants are those substances taken up by an organism from its surrounding medium through gill membranes, epithelial tissue, or from food and subsequently concentrated and retained in the body of the organism.

Carcinogenic pollutants are substances that are known to cause cancer in living organisms.

Coefficient of Variation (CV) is a measure of the data variability and is calculated as the estimated standard deviation divided by the arithmetic mean of the observed values.

Daily Discharge: Daily Discharge is defined as either: (1) the total mass of the constituent discharged over the calendar day (12:00 am through 11:59 pm) or any 24-hour period that reasonably represents a calendar day for purposes of sampling (as specified in the permit), for a constituent with limitations expressed in units of mass or; (2) the unweighted arithmetic mean measurement of the constituent over the day for a constituent with limitations expressed in other units of measurement (e.g., concentration).

The daily discharge may be determined by the analytical results of a composite sample taken over the course of one day (a calendar day or other 24-hour period defined as a day) or by the arithmetic mean of analytical results from one or more grab samples taken over the course of the day.

For composite sampling, if 1 day is defined as a 24-hour period other than a calendar day, the analytical result for the 24-hour period will be considered as the result for the calendar day in which the 24-hour period ends.

Detected, but Not Quantified (DNQ) are those sample results less than the RL, but greater than or equal to the laboratory's MDL.

Dilution Credit is the amount of dilution granted to a discharge in the calculation of a water quality-based effluent limitation, based on the allowance of a specified mixing zone. It is calculated from the dilution ratio or determined through conducting a mixing zone study or modeling of the discharge and receiving water.

Effluent Concentration Allowance (ECA) is a value derived from the water quality criterion/objective, dilution credit, and ambient background concentration that is used, in conjunction with the coefficient of variation for the effluent monitoring data, to calculate a long-term average (LTA) discharge concentration. The ECA has the same meaning as waste load allocation (WLA) as used in USEPA guidance (Technical Support Document For Water Quality-based Toxics Control, March 1991, second printing, EPA/505/2-90-001).

Enclosed Bays means indentations along the coast that enclose an area of oceanic water within distinct headlands or harbor works. Enclosed bays include all bays where the narrowest distance between the headlands or outermost harbor works is less than 75 percent of the greatest dimension of the enclosed portion of the bay. Enclosed bays include, but are not limited to, Humboldt Bay, Bodega Harbor, Tomales Bay, Drake's Estero, San Francisco Bay, Morro Bay, Los Angeles-Long Beach Harbor, Upper and Lower Newport Bay, Mission Bay, and San Diego Bay. Enclosed bays do not include inland surface waters or ocean waters.

Estimated Chemical Concentration is the estimated chemical concentration that results from the confirmed detection of the substance by the analytical method below the ML value.

Estuaries means waters, including coastal lagoons, located at the mouths of streams that serve as areas of mixing for fresh and ocean waters. Coastal lagoons and mouths of streams that are temporarily separated from the ocean by sandbars shall be considered estuaries. Estuarine waters shall be considered to extend from a bay or the open ocean to a point upstream where there is no significant mixing of fresh water and seawater. Estuarine waters included, but are not limited to, the Sacramento-San Joaquin Delta, as defined in CWC Section 12220, Suisun Bay, Carquinez Strait downstream to the Carquinez Bridge, and appropriate areas of the Smith, Mad, Eel, Noyo, Russian, Klamath, San Diego, and Otay rivers. Estuaries do not include inland surface waters or ocean waters.

Existing Discharger means any Discharger that is not a new Discharger. An existing Discharger includes an "increasing Discharger" (i.e., an existing Facility with treatment systems in place for its current discharge that is or will be expanding, upgrading, or modifying its existing permitted discharge after the effective date of this Policy).

Incompletely-Mixed Discharge: An Incompletely-Mixed Discharge is a discharge that contributes to a condition that does not meet the meaning of a completely-mixed discharge condition.

Infeasible: Infeasible means not capable of being accomplished in a successful manner within a reasonable period of time, taking into account economic, environmental, legal, social, and technological factors.

Inland Surface Waters are all surface waters of the State that do not include the ocean, enclosed bays, or estuaries.

Instantaneous Maximum Effluent Limitation: the highest allowable value for any single grab sample or aliquot (i.e., each grab sample or aliquot is independently compared to the instantaneous maximum limitation).

Instantaneous Minimum Effluent Limitation: the lowest allowable value for any single grab sample or aliquot (i.e., each grab sample or aliquot is independently compared to the instantaneous minimum limitation).

Load Allocation (LA) is the portion of a receiving water's total maximum daily load that is allocated to one of its non-point sources of pollution or to natural background sources.

Maximum Daily Effluent Limitation (MDEL) means the highest allowable daily discharge of a pollutant, over a calendar day (or 24-hour period). For pollutants with limitations expressed in units of mass, the daily discharge is calculated as the total mass of the pollutant discharged over the day. For pollutants with limitations expressed in other units of measurement, the daily discharge is calculated as the arithmetic mean measurement of the pollutant over the day.

Median is the middle measurement in a set of data. The median of a set of data is found by first arranging the measurements in order of magnitude (either increasing or decreasing order). If the number of measurements (n) is odd, then the median = $X_{(n+1)/2}$. If n is even, then the median = $(X_{n/2} + X_{(n/2)+1})/2$ (i.e., the midpoint between the $n/2$ and $n/2+1$).

Method Detection Limit (MDL) is the minimum concentration of a substance that can be measured and reported with 99 percent confidence that the analyte concentration is greater than zero, as defined in title 40 of the CFR, Part 136, Attachment B, revised as of July 3, 1999.

Minimum Level (ML) is the concentration at which the entire analytical system must give a recognizable signal and acceptable calibration point. The ML is the concentration in a sample that is equivalent to the concentration of the lowest calibration standard analyzed by a specific analytical procedure, assuming that all the method specified sample weights, volumes, and processing steps have been followed.

Mixing Zone is a limited volume of receiving water that is allocated for mixing with a wastewater discharge where water quality criteria can be exceeded without causing adverse effects to the overall water body.

New Discharger includes any building, structure, Facility, or installation from which there is, or may be, a discharge of pollutants, the construction of which commenced after the effective date of this Policy.

Not Detected (ND) means those sample results less than the laboratory's MDL.

Objectionable Bottom Deposits are an accumulation of materials or substances on or near the bottom of a water body, which creates conditions that adversely impact aquatic life, human health, beneficial uses, or aesthetics. These conditions include, but are not limited to, the accumulation of pollutants in the sediments and other conditions that result in harm to benthic organisms, production of food chain organisms, or fish egg development. The presence of such deposits shall be determined by Regional Water Board(s) on a case-by-case basis.

Ocean Waters are the territorial marine waters of the State as defined by California law to the extent these waters are outside of enclosed bays, estuaries, and coastal lagoons. Discharges to ocean waters are regulated in accordance with the State Water Board's California Ocean Plan.

Persistent Pollutants are substances for which degradation or decomposition in the environment is nonexistent or very slow.

Pollutant Minimization Program (PMP) means waste minimization and pollution prevention actions that include, but are not limited to, product substitution, waste stream recycling, alternative waste management methods, and education of the public and businesses. The goal of the PMP shall be to reduce all potential sources of a priority pollutant(s) through pollutant minimization (control) strategies, including pollution prevention measures as appropriate, to maintain the effluent concentration at or below the water quality-based effluent limitation. Pollution prevention measures may be particularly appropriate for persistent bioaccumulative priority pollutants where there is evidence that beneficial uses are being impacted. The Regional Water Board may consider cost effectiveness when establishing the requirements of a PMP. The completion and implementation of a Pollution Prevention Plan, if required pursuant to Water Code Section 13263.3(d), shall be considered to fulfill the PMP requirements.

Pollution Prevention means any action that causes a net reduction in the use or generation of a hazardous substance or other pollutant that is discharged into water and includes, but is not limited to, input change, operational improvement, production process change, and product reformulation (as defined in Water Code Section 13263.3). Pollution prevention does not include actions that merely shift a pollutant in wastewater from one environmental medium to another environmental medium, unless clear environmental benefits of such an approach are identified to the satisfaction of the State or Regional Water Board.

Public Entity includes the federal government or a state, county city and county, city, district, public authority, or public agency.

Reporting Level (RL) is the ML (and its associated analytical method) chosen by the Discharger for reporting and compliance determination from the MLs included in this Order. The MLs included in this Order correspond to approved analytical methods for reporting a sample result that are selected by the Regional Water Board either from Appendix 4 of the SIP in accordance with section 2.4.2 of the SIP or established in accordance with section 2.4.3 of the SIP. The ML is based on the proper application of method-based analytical procedures for sample preparation and the absence of any matrix interferences. Other factors may be applied to the ML depending on the specific sample preparation steps employed. For example, the treatment typically applied in cases where there are matrix-effects is to dilute the sample or sample aliquot by a factor of ten. In such cases, this additional factor must be applied to the ML in the computation of the RL.

Satellite Collection System is the portion, if any, of a sanitary sewer system owned or operated by a different public agency than the agency that owns and operates the wastewater treatment facility that a sanitary sewer system is tributary to.

Source of Drinking Water is any water designated as municipal or domestic supply (MUN) in a Regional Water Board Basin Plan.

Standard Deviation (σ) is a measure of variability that is calculated as follows:

$$\sigma = (\sum[(x - \mu)^2]/(n - 1))^{0.5}$$

where:

x is the observed value;

μ is the arithmetic mean of the observed values; and

n is the number of samples.

State Implementation Policy (SIP): The Policy for Implementation of Toxics Standards for Inland Surface Waters, Enclosed Bays, and Estuaries of California.

Teratogenic pollutants are substances that are known to cause structural abnormalities or birth defects in living organisms.

Toxicity Reduction Evaluation (TRE) is a study conducted in a step-wise process designed to identify the causative agents of effluent or ambient toxicity, isolate the sources of toxicity, evaluate the effectiveness of toxicity control options, and then confirm the reduction in toxicity. The first steps of the TRE consist of the collection of data relevant to the toxicity, including additional toxicity testing, and an evaluation of facility operations and maintenance practices, and Best Management Practices. A Toxicity Identification Evaluation (TIE) may be required as part of the TRE, if appropriate. (A TIE is a set of procedures to identify the specific chemical(s) responsible for toxicity. These procedures are performed in three phases (characterization, identification, and confirmation) using aquatic organism toxicity tests.)

ATTACHMENT B – MAP

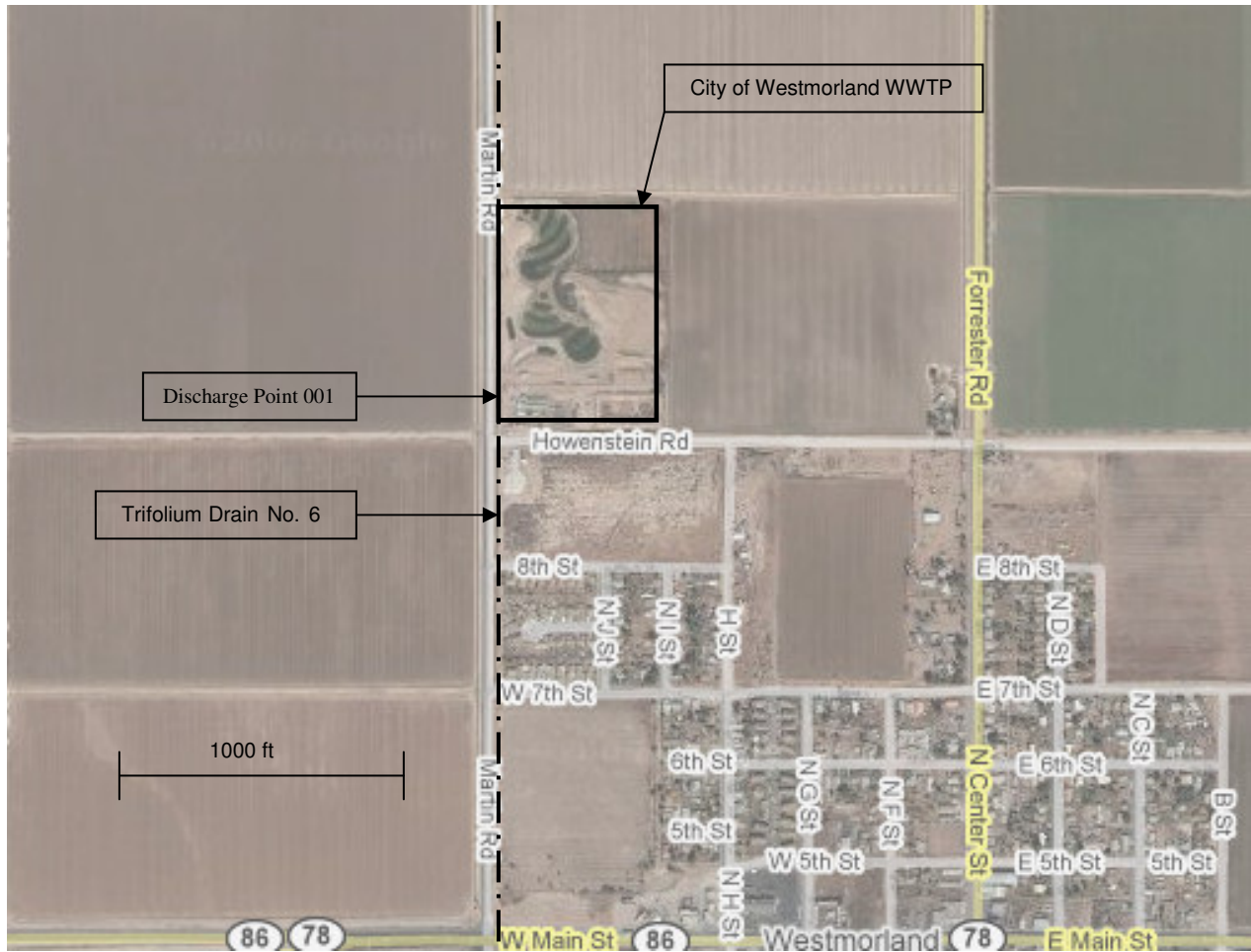

ATTACHMENT C – FLOW SCHEMATIC

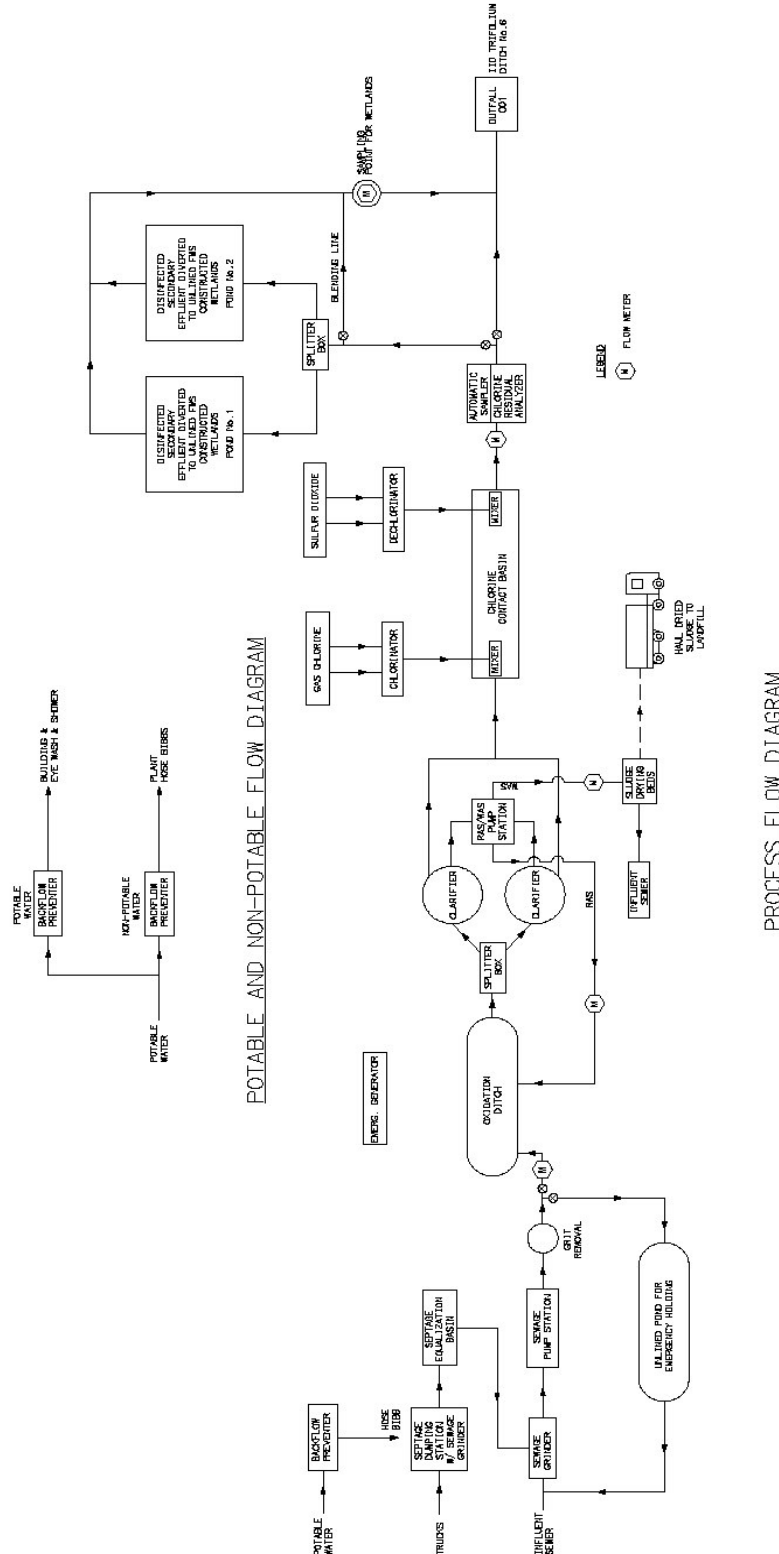

ATTACHMENT D – STANDARD PROVISIONS

I. STANDARD PROVISIONS – PERMIT COMPLIANCE

A. Duty to Comply

1. The Discharger must comply with all of the conditions of this Order. Any noncompliance constitutes a violation of the Clean Water Act (CWA) and the CWC and is grounds for enforcement action, for permit termination, revocation and reissuance, or modification; or denial of a permit renewal application. (40 C.F.R. § 122.41(a).)
2. The Discharger shall comply with effluent standards or prohibitions established under Section 307(a) of the CWA for toxic pollutants and with standards for sewage sludge use or disposal established under Section 405(d) of the CWA within the time provided in the regulations that establish these standards or prohibitions, even if this Order has not yet been modified to incorporate the requirement. (40 C.F.R. § 122.41(a)(1).)

B. Need to Halt or Reduce Activity Not a Defense

It shall not be a defense for a Discharger in an enforcement action that it would have been necessary to halt or reduce the permitted activity in order to maintain compliance with the conditions of this Order. (40 C.F.R. § 122.41(c).)

C. Duty to Mitigate

The Discharger shall take all reasonable steps to minimize or prevent any discharge or sludge use or disposal in violation of this Order that has a reasonable likelihood of adversely affecting human health or the environment. (40 C.F.R. § 122.41(d).)

D. Proper Operation and Maintenance

The Discharger shall at all times properly operate and maintain all facilities and systems of treatment and control (and related appurtenances) which are installed or used by the Discharger to achieve compliance with the conditions of this Order. Proper operation and maintenance also includes adequate laboratory controls and appropriate quality assurance procedures. This provision requires the operation of backup or auxiliary facilities or similar systems that are installed by a Discharger only when necessary to achieve compliance with the conditions of this Order. (40 C.F.R. § 122.41(e).)

E. Property Rights

1. This Order does not convey any property rights of any sort or any exclusive privileges. (40 C.F.R. § 122.41(g).)
2. The issuance of this Order does not authorize any injury to persons or property or invasion of other private rights, or any infringement of state or local law or regulations. (40 C.F.R. § 122.5(c).)

F. Inspection and Entry

The Discharger shall allow the Regional Water Board, State Water Board, United States Environmental Protection Agency (USEPA), and/or their authorized representatives (including an authorized contractor acting as their representative), upon the presentation of credentials and other documents, as may be required by law, to (40 C.F.R. § 122.41(i); Wat. Code, § 13383):

1. Enter upon the Discharger's premises where a regulated facility or activity is located or conducted, or where records are kept under the conditions of this Order (40 C.F.R. § 122.41(i)(1));
2. Have access to and copy, at reasonable times, any records that must be kept under the conditions of this Order (40 C.F.R. § 122.41(i)(2));
3. Inspect and photograph, at reasonable times, any facilities, equipment (including monitoring and control equipment), practices, or operations regulated or required under this Order (40 C.F.R. § 122.41(i)(3)); and
4. Sample or monitor, at reasonable times, for the purposes of assuring Order compliance or as otherwise authorized by the CWA or the Water Code, any substances or parameters at any location. (40 C.F.R. § 122.41(i)(4).)

G. Bypass

1. Definitions
 - a. "Bypass" means the intentional diversion of waste streams from any portion of a treatment facility. (40 C.F.R. § 122.41(m)(1)(i).)
 - b. "Severe property damage" means substantial physical damage to property, damage to the treatment facilities, which causes them to become inoperable, or substantial and permanent loss of natural resources that can reasonably be expected to occur in the absence of a bypass. Severe property damage does not mean economic loss caused by delays in production. (40 C.F.R. § 122.41(m)(1)(ii).)
2. Bypass not exceeding limitations. The Discharger may allow any bypass to occur which does not cause exceedances of effluent limitations, but only if it is for essential maintenance to assure efficient operation. These bypasses are not subject to the provisions listed in Standard Provisions – Permit Compliance I.G.3, I.G.4, and I.G.5 below. (40 C.F.R. § 122.41(m)(2).)
3. Prohibition of bypass. Bypass is prohibited, and the Regional Water Board may take enforcement action against a Discharger for bypass, unless (40 C.F.R. § 122.41(m)(4)(i)):
 - a. Bypass was unavoidable to prevent loss of life, personal injury, or severe property damage (40 C.F.R. § 122.41(m)(4)(i)(A));

- b. There were no feasible alternatives to the bypass, such as the use of auxiliary treatment facilities, retention of untreated wastes, or maintenance during normal periods of equipment downtime. This condition is not satisfied if adequate back-up equipment should have been installed in the exercise of reasonable engineering judgment to prevent a bypass that occurred during normal periods of equipment downtime or preventive maintenance (40 C.F.R. § 122.41(m)(4)(i)(B)); and
 - c. The Discharger submitted notice to the Regional Water Board as required under Standard Provisions – Permit Compliance I.G.5 below. (40 C.F.R. § 122.41(m)(4)(i)(C).)
 4. The Regional Water Board may approve an anticipated bypass, after considering its adverse effects, if the Regional Water Board determines that it will meet the three conditions listed in Standard Provisions – Permit Compliance I.G.3 above. (40 C.F.R. § 122.41(m)(4)(ii).)
 5. Notice
 - a. Anticipated bypass. If the Discharger knows in advance of the need for a bypass, it shall submit a notice, if possible at least 10 days before the date of the bypass. (40 C.F.R. § 122.41(m)(3)(i).)
 - b. Unanticipated bypass. The Discharger shall submit notice of an unanticipated bypass as required in Standard Provisions – Reporting V.E below (24-hour notice). (40 C.F.R. § 122.41(m)(3)(ii).)

H. Upset

Upset means an exceptional incident in which there is unintentional and temporary noncompliance with technology based permit effluent limitations because of factors beyond the reasonable control of the Discharger. An upset does not include noncompliance to the extent caused by operational error, improperly designed treatment facilities, inadequate treatment facilities, lack of preventive maintenance, or careless or improper operation. (40 C.F.R. § 122.41(n)(1).)

1. Effect of an upset. An upset constitutes an affirmative defense to an action brought for noncompliance with such technology based permit effluent limitations if the requirements of Standard Provisions – Permit Compliance I.H.2 below are met. No determination made during administrative review of claims that noncompliance was caused by upset, and before an action for noncompliance, is final administrative action subject to judicial review. (40 C.F.R. § 122.41(n)(2).)
2. Conditions necessary for a demonstration of upset. A Discharger who wishes to establish the affirmative defense of upset shall demonstrate, through properly signed, contemporaneous operating logs or other relevant evidence that (40 C.F.R. § 122.41(n)(3)):
 - a. An upset occurred and that the Discharger can identify the cause(s) of the upset (40 C.F.R. § 122.41(n)(3)(i));
 - b. The permitted facility was, at the time, being properly operated (40 C.F.R. § 122.41(n)(3)(ii));

- c. The Discharger submitted notice of the upset as required in Standard Provisions – Reporting V.E.2.b below (24-hour notice) (40 C.F.R. § 122.41(n)(3)(iii)); and
 - d. The Discharger complied with any remedial measures required under Standard Provisions – Permit Compliance I.C above. (40 C.F.R. § 122.41(n)(3)(iv).)
3. Burden of proof. In any enforcement proceeding, the Discharger seeking to establish the occurrence of an upset has the burden of proof. (40 C.F.R. § 122.41(n)(4).)

II. STANDARD PROVISIONS – PERMIT ACTION

A. General

This Order may be modified, revoked and reissued, or terminated for cause. The filing of a request by the Discharger for modification, revocation and reissuance, or termination, or a notification of planned changes or anticipated noncompliance does not stay any Order condition. (40 C.F.R. § 122.41(f).)

B. Duty to Reapply

If the Discharger wishes to continue an activity regulated by this Order after the expiration date of this Order, the Discharger must apply for and obtain a new permit. (40 C.F.R. § 122.41(b).)

C. Transfers

This Order is not transferable to any person except after notice to the Regional Water Board. The Regional Water Board may require modification or revocation and reissuance of the Order to change the name of the Discharger and incorporate such other requirements as may be necessary under the CWA and the Water Code. (40 C.F.R. § 122.41(l)(3); § 122.61.)

III. STANDARD PROVISIONS – MONITORING

- A. Samples and measurements taken for the purpose of monitoring shall be representative of the monitored activity. (40 C.F.R. § 122.41(j)(1).)
- B. Monitoring results must be conducted according to test procedures under Part 136 or, in the case of sludge use or disposal, approved under Part 136 unless otherwise specified in Part 503 unless other test procedures have been specified in this Order. (40 C.F.R. § 122.41(j)(4); § 122.44(i)(1)(iv).)

IV. STANDARD PROVISIONS – RECORDS

- A. Except for records of monitoring information required by this Order related to the Discharger's sewage sludge use and disposal activities, which shall be retained for a period of at least five years (or longer as required by Part 503), the Discharger shall retain records of all monitoring information, including all calibration and maintenance records and all original strip chart recordings for continuous monitoring instrumentation, copies of all reports required by this Order, and records of all data used to complete the application for this Order, for a period of at least three (3) years from the date of the sample, measurement, report or application. This period may be extended by request of the Regional Water Board Executive Officer at any time. (40 C.F.R. § 122.41(j)(2).)

B. Records of monitoring information shall include:

1. The date, exact place, and time of sampling or measurements (40 C.F.R. § 122.41(j)(3)(i));
2. The individual(s) who performed the sampling or measurements (40 C.F.R. § 122.41(j)(3)(ii));
3. The date(s) analyses were performed (40 C.F.R. § 122.41(j)(3)(iii));
4. The individual(s) who performed the analyses (40 C.F.R. § 122.41(j)(3)(iv));
5. The analytical techniques or methods used (40 C.F.R. § 122.41(j)(3)(v)); and
6. The results of such analyses. (40 C.F.R. § 122.41(j)(3)(vi).)

C. Claims of confidentiality for the following information will be denied (40 C.F.R. § 122.7(b)):

1. The name and address of any permit applicant or Discharger (40 C.F.R. § 122.7(b)(1)); and
2. Permit applications and attachments, permits and effluent data. (40 C.F.R. § 122.7(b)(2).)

V. STANDARD PROVISIONS – REPORTING

A. Duty to Provide Information

The Discharger shall furnish to the Regional Water Board, State Water Board, or USEPA within a reasonable time, any information which the Regional Water Board, State Water Board, or USEPA may request to determine whether cause exists for modifying, revoking and reissuing, or terminating this Order or to determine compliance with this Order. Upon request, the Discharger shall also furnish to the Regional Water Board, State Water Board, or USEPA copies of records required to be kept by this Order. (40 C.F.R. § 122.41(h); Wat. Code, § 13267.)

B. Signatory and Certification Requirements

1. All applications, reports, or information submitted to the Regional Water Board, State Water Board, and/or USEPA shall be signed and certified in accordance with Standard Provisions – Reporting V.B.2, V.B.3, V.B.4, and V.B.5 below. (40 C.F.R. § 122.41(k).)
2. All permit applications shall be signed by either a principal executive officer or ranking elected official. For purposes of this provision, a principal executive officer of a federal agency includes: (i) the chief executive officer of the agency, or (ii) a senior executive officer having responsibility for the overall operations of a principal geographic unit of the agency (e.g., Regional Administrators of USEPA). (40 C.F.R. § 122.22(a)(3).)
3. All reports required by this Order and other information requested by the Regional Water Board, State Water Board, or USEPA shall be signed by a person described in Standard Provisions – Reporting V.B.2 above, or by a duly authorized representative of that person. A person is a duly authorized representative only if:

- a. The authorization is made in writing by a person described in Standard Provisions – Reporting V.B.2 above (40 C.F.R. § 122.22(b)(1));
 - b. The authorization specifies either an individual or a position having responsibility for the overall operation of the regulated facility or activity such as the position of plant manager, operator of a well or a well field, superintendent, position of equivalent responsibility, or an individual or position having overall responsibility for environmental matters for the company. (A duly authorized representative may thus be either a named individual or any individual occupying a named position.) (40 C.F.R. § 122.22(b)(2)); and
 - c. The written authorization is submitted to the Regional Water Board and State Water Board. (40 C.F.R. § 122.22(b)(3).)
4. If an authorization under Standard Provisions – Reporting V.B.3 above is no longer accurate because a different individual or position has responsibility for the overall operation of the facility, a new authorization satisfying the requirements of Standard Provisions – Reporting V.B.3 above must be submitted to the Regional Water Board and State Water Board prior to or together with any reports, information, or applications, to be signed by an authorized representative. (40 C.F.R. § 122.22(c).)
 5. Any person signing a document under Standard Provisions – Reporting V.B.2 or V.B.3 above shall make the following certification:

“I certify under penalty of law that this document and all attachments were prepared under my direction or supervision in accordance with a system designed to assure that qualified personnel properly gather and evaluate the information submitted. Based on my inquiry of the person or persons who manage the system or those persons directly responsible for gathering the information, the information submitted is, to the best of my knowledge and belief, true, accurate, and complete. I am aware that there are significant penalties for submitting false information, including the possibility of fine and imprisonment for knowing violations.” (40 C.F.R. § 122.22(d).)

C. Monitoring Reports

1. Monitoring results shall be reported at the intervals specified in the MRP (Attachment E) in this Order. (40 C.F.R. § 122.22(l)(4).)
2. Monitoring results must be reported on a Discharge Monitoring Report (DMR) form or forms provided or specified by the Regional Water Board or State Water Board for reporting results of monitoring of sludge use or disposal practices. (40 C.F.R. § 122.41(l)(4)(i).)
3. If the Discharger monitors any pollutant more frequently than required by this Order using test procedures approved under Part 136 or, in the case of sludge use or disposal, approved under Part 136 unless otherwise specified in Part 503, or as specified in this Order, the results of this monitoring shall be included in the calculation and reporting of the data submitted in the DMR or sludge reporting form specified by the Regional Water Board. (40 C.F.R. § 122.41(l)(4)(ii).)

4. Calculations for all limitations, which require averaging of measurements, shall utilize an arithmetic mean unless otherwise specified in this Order. (40 C.F.R. § 122.41(l)(4)(iii).)

D. Compliance Schedules

Reports of compliance or noncompliance with, or any progress reports on, interim and final requirements contained in any compliance schedule of this Order, shall be submitted no later than 14 days following each schedule date. (40 C.F.R. § 122.41(l)(5).)

E. Twenty-Four Hour Reporting

1. The Discharger shall report any noncompliance that may endanger health or the environment. Any information shall be provided orally within 24 hours from the time the Discharger becomes aware of the circumstances. A written submission shall also be provided within five (5) days of the time the Discharger becomes aware of the circumstances. The written submission shall contain a description of the noncompliance and its cause; the period of noncompliance, including exact dates and times, and if the noncompliance has not been corrected, the anticipated time it is expected to continue; and steps taken or planned to reduce, eliminate, and prevent reoccurrence of the noncompliance. (40 C.F.R. § 122.41(l)(6)(i).)
2. The following shall be included as information that must be reported within 24 hours under this paragraph (40 C.F.R. § 122.41(l)(6)(ii)):
 - a. Any unanticipated bypass that exceeds any effluent limitation in this Order. (40 C.F.R. § 122.41(l)(6)(ii)(A).)
 - b. Any upset that exceeds any effluent limitation in this Order. (40 C.F.R. § 122.41(l)(6)(ii)(B).)
3. The Regional Water Board may waive the above-required written report under this provision on a case-by-case basis if an oral report has been received within 24 hours. (40 C.F.R. § 122.41(l)(6)(iii).)

F. Planned Changes

The Discharger shall give notice to the Regional Water Board as soon as possible of any planned physical alterations or additions to the permitted facility. Notice is required under this provision only when (40 C.F.R. § 122.41(l)(1)):

1. The alteration or addition to a permitted facility may meet one of the criteria for determining whether a facility is a new source in Section 122.29(b) (40 C.F.R. § 122.41(l)(1)(i)); or
2. The alteration or addition could significantly change the nature or increase the quantity of pollutants discharged. This notification applies to pollutants that are not subject to effluent limitations in this Order. (40 C.F.R. § 122.41(l)(1)(ii).)
3. The alteration or addition results in a significant change in the Discharger's sludge use or disposal practices, and such alteration, addition, or change may justify the application of permit conditions that are different from or absent in the existing permit, including notification of additional use or disposal sites not reported during the permit application process or not reported pursuant to an approved land application plan. (40 C.F.R. § 122.41(l)(1)(iii).)

G. Anticipated Noncompliance

The Discharger shall give advance notice to the Regional Water Board or State Water Board of any planned changes in the permitted facility or activity that may result in noncompliance with General Order requirements. (40 C.F.R. § 122.41(l)(2).)

H. Other Noncompliance

The Discharger shall report all instances of noncompliance not reported under Standard Provisions – Reporting V.C, V.D, and V.E above at the time monitoring reports are submitted. The reports shall contain the information listed in Standard Provision – Reporting V.E above. (40 C.F.R. § 122.41(l)(7).)

I. Other Information

When the Discharger becomes aware that it failed to submit any relevant facts in a permit application, or submitted incorrect information in a permit application or in any report to the Regional Water Board, State Water Board, or USEPA, the Discharger shall promptly submit such facts or information. (40 C.F.R. § 122.41(l)(8).)

VI. STANDARD PROVISIONS – ENFORCEMENT

- A. The Regional Water Board is authorized to enforce the terms of this permit under several provisions of the Water Code, including, but not limited to, Sections 13385, 13386, and 13387.

VII. ADDITIONAL PROVISIONS – NOTIFICATION LEVELS

A. Publicly-Owned Treatment Works (POTWs)

All POTWs shall provide adequate notice to the Regional Water Board of the following (40 C.F.R. § 122.42(b)):

1. Any new introduction of pollutants into the POTW from an indirect discharger that would be subject to Sections 301 or 306 of the CWA if it were directly discharging those pollutants (40 C.F.R. § 122.42(b)(1)); and
2. Any substantial change in the volume or character of pollutants being introduced into that POTW by a source introducing pollutants into the POTW at the time of adoption of the Order. (40 C.F.R. § 122.42(b)(2).)
3. Adequate notice shall include information on the quality and quantity of effluent introduced into the POTW as well as any anticipated impact of the change on the quantity or quality of effluent to be discharged from the POTW. (40 C.F.R. § 122.42(b)(3).)

ATTACHMENT E – MONITORING AND REPORTING PROGRAM

Table of Contents

Attachment E – Monitoring and Reporting Program (MRP) E-2

I. General Monitoring Provisions E-2

II. Monitoring Locations E-4

III. Influent Monitoring Requirements..... E-5

 A. Monitoring Location INF-001 E-5

IV. Effluent Monitoring Requirements E-6

 A. Monitoring Location EFF-001 E-6

V. Whole Effluent Toxicity Testing Requirements E-8

 A. Monitoring Requirements E-8

 B. Quality Assurance E-9

 C. Accelerated Monitoring Requirements E-9

 D. Conducting Toxicity Identification Evaluations and Toxicity Reduction Evaluations..... E-10

 E. Definition of Toxicity E-11

 F. Reporting E-11

VI. Land Discharge Monitoring Requirements – Not Applicable E-12

VII. Reclamation Monitoring Requirements – Not Applicable E-12

VIII. Receiving Water Monitoring Requirements – Surface Water and Groundwater..... E-12

 A. Monitoring Location – RSW-001 E-12

 B. Monitoring Location – RSW-002 E-13

 C. Visual Monitoring Upstream and Downstream Receiving Water Sampling Points E-14

IX. Other Monitoring Requirements E-14

 A. Water Supply Monitoring..... E-14

 B. Monitoring Location SLD-001..... E-15

 C. Pretreatment Monitoring – Not Applicable E-15

 D. Monitoring Location INT-001 E-15

X. Reporting Requirements E-15

 A. General Monitoring and Reporting Requirements E-15

 B. Self Monitoring Reports (SMRs)..... E-16

 C. Discharge Monitoring Reports (DMRs)..... E-19

 D. Other Reports E-19

List of Tables

Table E-1. Monitoring Station Locations E-4

Table E-2. Influent Monitoring INF-001 E-5

Table E-3. Effluent Monitoring EFF-001 E-6

Table E-4. Whole Effluent Toxicity Testing..... E-8

Table E-5. Whole Effluent Toxicity Test Species..... E-8

Table E-6. Receiving Water Monitoring RSW-001 E-13

Table E-7. Receiving Water Monitoring RSW-002 E-14

Table E-8. Sludge Monitoring SLD-001..... E-15

Table E-9. Monitoring Periods and Reporting Schedule..... E-17

Table E-10. Self-Monitoring Report – Mailing Address..... E-18

Table E-11. Discharge Monitoring Reports – Mailing Addresses..... E-19

Table E-12. Operations and Maintenance Report E-19

Attachment E – Monitoring and Reporting Program (MRP)

The CFR Section 122.48 requires that all NPDES permits specify monitoring and reporting requirements. Water Code Sections 13267 and 13383 also authorize the Regional Water Quality Control Board (Regional Water Board) to require technical and monitoring reports. This MRP establishes monitoring and reporting requirements, which implement the federal and California regulations.

I. GENERAL MONITORING PROVISIONS

- A.** Samples and measurements taken as required herein shall be representative of the volume and nature of the monitored discharge. All samples shall be taken at the monitoring locations specified below and, unless otherwise specified, before the monitored flow joins or is diluted by any other waste stream, body of water, or substance. Monitoring locations shall not be changed without notification to and the approval of this Regional Water Board.
- B.** Appropriate flow measurement devices and methods consistent with accepted scientific practices shall be selected and used to ensure the accuracy and reliability of measurements of the volume of monitored discharges. The devices shall be installed, calibrated and maintained to ensure that the accuracy of the measurements is consistent with the accepted capability of that type of device. Devices selected shall be capable of measuring flows with a maximum deviation of less than ± 10 percent from true discharge rates throughout the range of expected discharge volumes. Guidance in selection, installation, calibration and operation of acceptable flow measurement devices can be obtained from the following references:
 - 1. "A Guide to Methods and Standards for the Measurement of Water Flow," U.S. Department of Commerce, National Bureau of Standards, NBS Special Publication 421, May 1975, 96 pp. (Available from the U.S. Government Printing Office, Washington, D.C. 20402. Order by SD Catalog No. C13.10:421.)
 - 2. "Water Measurement Manual," U.S. Department of Interior, Bureau of Reclamation, Second Edition, Revised Reprint, 1974, 327 pp. (Available from the U.S. Government Printing Office, Washington D.C. 20402. Order by Catalog No. 172.19/2:W29/2, Stock No. S/N 24003-0027.)
 - 3. "Flow Measurement in Open Channels and Closed Conduits," U.S. Department of Commerce, National Bureau of Standards, NBS Special Publication 484, October 1977, 982 pp. (Available in paper copy or microfiche from National Technical Information Services (NTIS) Springfield, VA 22151. Order by NTIS No. PB-273 535/5ST.)
 - 4. "NPDES Compliance Sampling Manual," U.S. Environmental Protection Agency, Office of Water Enforcement, Publication MCD-51, 1977, 140 pp. (Available from the General Services Administration (8FFS), Centralized Mailing Lists Services, Building 41, Denver Federal Center, CO 80225.)
- C.** Unless otherwise approved by the Regional Water Board's Executive Officer, all analyses shall be conducted at a laboratory certified for such analyses by the State Department of Health Services. All analyses shall be conducted in accordance with the latest edition of "Guidelines Establishing Test Procedures for Analysis of Pollutants", promulgated by the United States Environmental Protection Agency.

- D.** All monitoring instruments and devices used by the discharger to fulfill the prescribed monitoring program shall be properly maintained and calibrated as necessary to ensure their continued accuracy. All flow measurement devices shall be calibrated at least once per year to ensure continued accuracy of the devices.
- E.** Monitoring results, including noncompliance, shall be reported at intervals and in a manner specified in this MRP.
- F.** If the facility is not in operation, or there is no discharge during a required reporting period, the Discharger shall forward a letter to the Regional Water Board indicating that there has been no activity during the required reporting period.

II. MONITORING LOCATIONS

The Discharger shall establish the following monitoring locations to demonstrate compliance with the effluent limitations, discharge specifications, and other requirements in this Order:

Table E-1. Monitoring Station Locations

Discharge Point Name	Monitoring Location Name	Monitoring Location Description
---	INF-001	Wastewater influent to the treatment facility
001	EFF-001	Effluent wastewater from the treatment facility; Latitude 33° 02' 45" North and Longitude 115° 37' 44" West.
---	RSW-001	Receiving water (Trifolium Drain No. 6) monitoring location not to exceed 100 feet upstream from the location where effluent enters the Trifolium Drain No. 6.
---	RSW-002	Receiving water (Trifolium Drain No. 6) monitoring location not to exceed 200 feet downstream from the location where the effluent enters the Trifolium Drain No. 6.
---	SLD-001	Sludge, prior to removal and disposal
---	INT-001	Visual freeboard monitoring shall occur.

III. INFLUENT MONITORING REQUIREMENTS

A. MONITORING LOCATION INF-001

1. The Discharger shall monitor the wastewater influent to the treatment facility at INF-001 as follows:

Table E-2. Influent Monitoring INF-001

Parameter	Units	Sample Type	Minimum Sampling Frequency	Required Analytical Test Method
Flow	MGD ¹	Flow meter reading	1x/Day	See Footnote 2
Biochemical Oxygen Demand (BOD) (5-Day @ 20 Deg. C)	mg/L ³	24-hour composite ⁴	1x/Week	See Footnote 5
Total Suspended Solids (TSS)	mg/L	24-hour composite ⁴	1x/Week	See Footnote 5

¹ MGD = Million Gallons per Day

² Reported monthly with monthly average daily flow

³ mg/L = milligrams per liter

⁴ Samples shall be flow-proportional composite samples.

⁵ Pollutants shall be analyzed using the analytical methods described in 40 CFR Part 136; for priority pollutants the methods must meet the lowest minimum levels (MLs) specified in Attachment 4 of the SIP, included as Attachment I. Where no methods are specified for a given pollutant, the methods must be approved by this Regional Water Board or the State Water Board.

IV. EFFLUENT MONITORING REQUIREMENTS

A. MONITORING LOCATION EFF-001

1. The Discharger shall monitor secondary treated wastewater at EFF-001 as follows. If more than one analytical test method is listed for a given parameter, the Discharger must select from the listed methods and corresponding Minimum Level:

Table E-3. Effluent Monitoring EFF-001

Parameter	Units	Sample Type	Minimum Sampling Frequency	Required Analytical Test Method
Flow	MGD	Flow Meter Reading	Continuous	See Footnote 1
Chlorine, Total Residual	mg/L	Continuous	Continuous ²	See Footnote 3
	lbs/day			
Enterococci	MPN ⁴ / 100 ml	Grab	5x/Month ⁵	See Footnote 3
Escherichia Coli (E. Coli)	MPN/ 100 ml	Grab	5x/Month ⁵	See Footnote 3
Fecal Coliform	MPN/ 100 ml	Grab	5x/Month ⁵	See Footnote 3
Dissolved Oxygen	mg/L	Grab	1x/Week	See Footnote 3
pH	pH Units	Grab	1x/Week	See Footnote 3
Temperature	°F	Grab	1x/Week	See Footnote 3
BOD 5-Day 20° C	mg/L	24-Hour Composite ⁶	1x/Week	See Footnote 3
	lbs/day			
Total Suspended Solids (TSS)	mg/L	24-Hour Composite ⁶	1x/Week	See Footnote 3
	lbs/day			
Copper, Total Recoverable	µg/L	24-Hour Composite ⁶	1x/Month	See Footnote 3
	lbs/day			
Selenium, Total Recoverable	µg/L	24-Hour Composite ⁶	1x/Month	See Footnote 3
	lbs/day			
Total Dissolved Solids	mg/L	24-Hour Composite ⁶	1x/Month	See Footnote 3
Ammonia Nitrogen, Total (as N)	mg/L	Grab	1x/Quarter	See Footnote 3
Hardness (as CaCO ₃)	mg/L	24-Hour Composite ⁶	1x/Quarter	See Footnote 3
Nitrates as Nitrogen (as N)	mg/L	Grab	1x/Quarter	See Footnote 3
Nitrites as Nitrogen (as N)	mg/L	Grab	1x/Quarter	See Footnote 3
Nitrogen, Total (as N)	mg/L	Grab	1x/Quarter	See Footnote 3
Ortho-Phosphate (as P)	mg/L	Grab	1x/Quarter	See Footnote 3
Phosphate, Total (as P)	mg/L	Grab	1x/Quarter	See Footnote 3
Sulfates	mg/L	Grab	1x/Quarter	See Footnote 3
Oil and Grease	mg/L	Grab	1x/Year	See Footnote 3
Priority Pollutants ^{7,8}	µg/L	24-Hour Composite ⁶	1x/Year	See Footnote 3

- ¹ Report Total Daily Flow.
- ² Until such time when continuous monitoring for total residual chlorine is commenced, compliance with effluent limitations for total residual chlorine will be determined using grab samples collected throughout the operators' work period. Samples shall be collected within the first and last hours of the operators' work period, and at least every 4 hours in between. The Discharger shall provide all monitoring data for total residual chlorine and report the maximum daily concentration with each monthly SMR.
- ³ Pollutants shall be analyzed using the analytical methods described in 40 CFR Part 136. For priority pollutants, the methods must meet the lowest minimum levels (MLs) specified in Attachment 4 of the SIP, included as Attachment I. Where no methods are specified for a given pollutant, the methods must be approved by this Regional Water Board or the State Water Board.
- ⁴ MPN = Most Probable number.
- ⁵ Five samples equally spaced over a 30-day period with a minimum of one sample per week.
- ⁶ Samples shall be flow-proportional composite samples.
- ⁷ Priority Pollutants as defined by the California Toxics Rule (CTR) defined in Finding II.I of the Limitations and Discharge Requirements of this Order, and included as Attachment G. For priority pollutants the methods must meet the lowest minimum levels (MLs) specified in Attachment 4 of the SIP, where no methods are specified for a given pollutant, by methods approved by this Regional Water Board or the State Water Board.
- ⁸ Volatile organic samples and samples with holding times of less than 24 hours shall be grab samples; the remainder shall be 24-hour composite samples.

V. WHOLE EFFLUENT TOXICITY TESTING REQUIREMENTS

A. MONITORING REQUIREMENTS

1. Bioassays shall be performed to evaluate the toxicity of the discharged wastewater in accordance with the following procedures unless otherwise specified by the Regional Water Board’s Executive Officer or his designee:
 - a. Bioassays shall be conducted on a sensitive fish species and an invertebrate species as approved by the Regional Water Board’s Executive Officer. *Pimephales promelas* (fathead minnow) and *Ceriodaphnia dubia* (water flea) are suggested test species that may be utilized. The bioassays shall be conducted in accordance with the protocol given in EPA/821-R-02-013 – *Short Term Methods for Estimating the Chronic Toxicity of Effluent and Receiving Waters to Freshwater Organisms, 4th Edition*, and EPA/821-R-02-012 – *Methods for Measuring the Acute Toxicity of Effluents and Receiving Waters for Freshwater and Marine Organisms, 5th Edition*, or subsequent editions.
2. The Discharger shall conduct chronic and acute toxicity testing on the final effluent discharged at monitoring point EFF-001.

Table E-4. Whole Effluent Toxicity Testing

Test	Units	Sample Type	Minimum Sampling Frequency
Chronic Toxicity	TU _c ¹	Grab	1x/Quarter
Acute Toxicity	TU _a ^{2,3,4} & % Survival	Grab	1x/Quarter

¹ Chronic toxicity units.

² Acute toxicity units.

³ Acute Bioassay results can be calculated from chronic bioassay test for *Pimephales promelas*.

⁴ Discharger can provide Pass/Fail when using a t-test.

3. Both test species given below shall be used to measure chronic and acute toxicity:

Table E-5. Whole Effluent Toxicity Test Species

Species	Effect	Test Duration (days)	Reference
Fathead Minnow (<i>Pimephales promelas</i>)	Larval Survival and Growth	7	EPA/821-R-02-013 (Chronic) EPA/821-R-02-012 ¹ (Acute)
Water Flea (<i>Ceriodaphnia dubia</i>)	Survival and Reproduction	7	EPA/821-R-02-013 (Chronic) EPA/821-R-02-012 (Acute)

¹ Acute bioassay results can be calculated from chronic bioassay test for *Pimephales promelas*.

4. Toxicity Test References for Conducting Toxicity Tests
 - a. Methods for Measuring the Acute Toxicity of Effluents and Receiving Waters to Freshwater and Marine Organisms, Fifth Edition, EPA/821-R-02-012, October 2002 or subsequent editions.

- b. Short Term Methods for Estimating the Chronic Toxicity of Effluents and Receiving Water for Freshwater Organisms, Fourth Edition, EPA/821-R-02-013, October 2002 or subsequent editions.

B. QUALITY ASSURANCE

1. Dilution and control waters may be obtained from an unaffected area of receiving waters. Synthetic (standard) dilution is an option and may be used if the above source is suspected to have toxicity greater than 1.0 TU_c.
2. A series of at least five dilutions and a control shall be tested for chronic toxicity testing and may be used for acute toxicity testing. The series shall include the following concentrations: 12.5, 25, 50, 75, and 100 percent effluent.
3. For the acute toxicity testing using a t-test, two dilutions shall be used, i.e., 100 percent effluent and a control (when a t-test is used instead of an LC50).
4. If organisms are not cultured in-house, concurrent testing with a referenced toxicant shall be conducted. Where organisms are cultured in-house, monthly reference toxicant testing is sufficient. Reference toxicant tests also shall be conducted using the same test conditions as the effluent toxicity tests (e.g., same test duration).
5. If either the reference toxicant test or effluent test does not meet all test acceptability criteria (TAC) as specified in the toxicity test references, then the permittee must re-sample and retest within 15 working days or as soon as possible. The retesting period begins when the Discharger receives the test results that indicate retesting is needed or collects the first sample required to complete the retest.
6. The reference toxicant and effluent tests must meet the upper and lower bounds on test sensitivity as determined by calculating the percent minimum significant difference (PMSD) for each test result. The test sensitivity bound is specified for each test method in the respective methods manuals.

C. ACCELERATED MONITORING REQUIREMENTS

When the numeric toxicity trigger is exceeded during regular toxicity monitoring, and the testing meets all test acceptability criteria, the Discharger shall initiate accelerated monitoring to confirm the effluent toxicity.

The Discharger shall implement an accelerated monitoring frequency consisting of performing three (3) toxicity tests in a nine (9)-week period beginning from the date the Discharger receives an initial exceedance of the chronic or acute toxicity triggers described below:

Any chronic toxicity test that exceeds 2 chronic toxicity units (TU_c) or a three (3)-sample median (consecutive samples) that exceeds 1 TU_c shall trigger an accelerated monitoring frequency. In addition, any acute toxicity test results showing high toxicity shall trigger an accelerated monitoring frequency. High acute toxicity is defined as follows:

- a. Less than 80% survival when acute toxicity is calculated from results of the chronic toxicity test (only for *Pimephales promelas*), or

- b. Less than 90% survival when acute toxicity is calculated from the results of the acute toxicity test, or
- c. Results of acute toxicity t-test for 100% effluent concentration that is reported as failed.

The scope of accelerated monitoring shall be limited to the species and analytical method that failed the test.”

The numeric toxicity triggers are not an effluent limitation, they are the toxicity threshold at which the Discharger is required to perform accelerated monitoring to confirm effluent toxicity, as well as, the threshold to initiate a toxicity reduction evaluation (TRE) if toxicity is confirmed.

If implementation of the generic TRE workplan indicates the source of the exceedance of the toxicity trigger (for instance, a temporary plant upset), then only one additional test is necessary. If exceedance of the toxicity trigger is detected in this test, the Discharger will continue with accelerated monitoring requirements or implement the Toxicity Identification and Toxicity Reduction Evaluations.

If none of the three tests indicated exceedance of the toxicity trigger, then the permittee may return to the normal bioassay testing frequency.

D. CONDUCTING TOXICITY IDENTIFICATION EVALUATIONS AND TOXICITY REDUCTION EVALUATIONS

- 1. A Toxicity Identification Evaluation (TIE) shall be triggered if testing from the accelerated monitoring frequency indicates any of the following:
 - a. Two of the three accelerated chronic toxicity tests are reported as failed tests meeting any of the conditions specified in section V.C of this MRP; or
 - b. Two of the three acute toxicity tests are reported as failed tests meeting any of the conditions specified in section V.C of this MRP.
 - c. The TIE shall be initiated within 15 days following failure of the second accelerated monitoring test.
 - d. If a TIE is triggered prior to the completion of the accelerated testing, the accelerated testing schedule may be terminated, or used as necessary in performing the TIE.
- 2. The TIE shall be conducted to identify and evaluate toxicity in accordance with procedures recommended by the United States Environmental Protection Agency (USEPA) which include the following:
 - a. Toxicity Identification Evaluation: Characterization of Chronically Toxic Effluents, Phase I, (USEPA, 1992a);
 - b. Methods for Aquatic Toxicity Identification Evaluations: Phase I Toxicity Characterization Procedures, Second Edition (USEPA, 1991a);
 - c. Methods for Aquatic Toxicity Identification Evaluations: Phase II Toxicity Identification Procedures for Sampling Exhibiting Acute and Chronic Toxicity (USEPA, 1993a);

- d. Methods for Aquatic Toxicity Identification Evaluations: Phase III Toxicity Confirmation Procedures for Samples Exhibiting Acute and Chronic Toxicity (USEPA, 1993b);
3. As part of the TIE investigation, the Discharger shall be required to implement its TRE workplan. The Discharger shall take all reasonable steps to control toxicity once the source of the toxicity is identified. A failure to conduct required toxicity tests or a TRE within a designated period shall result in the establishment of numerical effluent limitations for chronic toxicity in a permit or appropriate enforcement action. Recommended guidance in conducting a TRE include the following:
 - a. Toxicity Reduction Evaluation Guidance for Municipal Wastewater Treatment Plants, August 1999, EPA/833B-99/002;
 - b. Clarifications Regarding Toxicity Reduction and Identification Evaluations in the NPDES Program dated March 27, 2001, USEPA Office of Wastewater Management, Office of Regulatory Enforcement.

E. DEFINITION OF TOXICITY

1. Chronic toxicity measures sublethal effect (e.g., reduced growth, reproduction) to experimental test organisms exposed to an effluent or ambient waters compared to that of the control organisms.
2. Chronic toxicity shall be measured in TU_c , where $TU_c = 100/NOEC$. The no observed effect concentration (NOEC) is the highest concentration of toxicant to which organisms are exposed in a chronic test that causes no observable adverse effect on the test organisms (e.g., the highest concentration of toxicant to which the values for the observed responses are not statistically significantly different from the controls).
3. Acute toxicity is a measure of primarily lethal effects that occur over a ninety-six (96) hour period. Acute toxicity for *Pimephales promelas* can be calculated from the results of the chronic toxicity test for *Pimephales promelas* and reported along with the results of each chronic test. Acute toxicity for *Ceriodaphnia dubia* cannot be calculated from the results of the chronic toxicity test for *Ceriodaphnia dubia* because the test design is not amenable to calculation of a lethal concentration (LC50) value as needed for the acute requirement.
4. Acute toxicity shall be measured in Tu_a , where $Tu_a = 100/LC50$ and percent survival or as pass/fail using a t-test. LC50 is the toxicant concentration that would cause death in 50 percent of the test organisms.

F. REPORTING

1. The Discharger shall submit the analysis and results of the toxicity test, including any accelerated testing in toxicity units with the discharge monitoring reports for the month in which the last test is conducted.
2. If a TIE is conducted the Discharger shall submit the results of the TIE with the discharge monitoring reports for the month in which the final report is completed.
3. If the TRE Workplan has been initiated, the Discharger shall report on the progress of the actions being taken and include this information with each monthly monitoring report.

VI. LAND DISCHARGE MONITORING REQUIREMENTS – NOT APPLICABLE

VII. RECLAMATION MONITORING REQUIREMENTS – NOT APPLICABLE

VIII. RECEIVING WATER MONITORING REQUIREMENTS – SURFACE WATER AND GROUNDWATER

A. MONITORING LOCATION – RSW-001

1. The Discharger shall monitor Trifolium Drain No. 6 at RSW-001 as follows. In the event that no receiving water is present at RWS-001, no receiving water monitoring data are required for station RSW-001.

Table E-6. Receiving Water Monitoring RSW-001

Parameter	Units	Sample Type	Minimum Sampling Frequency	Required Analytical Test Method
Ammonia Nitrogen, Total (as N)	mg/L	Grab	1xQuarter	See Footnote 1
Dissolved Oxygen	mg/L	Grab	1xQuarter	See Footnote 1
Hardness (as CaCO ₃)	mg/L	Grab	1xQuarter	See Footnote 1
Nitrates as Nitrogen (as N)	mg/L	Grab	1xQuarter	See Footnote 1
Nitrites as Nitrogen (as N)	mg/L	Grab	1xQuarter	See Footnote 1
Nitrogen, Total (as N)	mg/L	Grab	1xQuarter	See Footnote 1
Ortho-Phosphate (as P)	mg/L	Grab	1xQuarter	See Footnote 1
pH	pH Units	Grab	1xQuarter	See Footnote 1
Phosphate, Total (as P)	mg/L	Grab	1xQuarter	See Footnote 1
Temperature	^o F	Grab	1xQuarter	See Footnote 1
Total Dissolved Solids	mg/L	Grab	1xQuarter	See Footnote 1
Priority Pollutants ²	µg/L	Grab	1x/Year	See Footnote 1

¹ Pollutants shall be analyzed using the analytical methods described in 40 CFR Part 136; for priority pollutants the methods must meet the lowest minimum levels (MLs) specified in Attachment 4 of the SIP, included as Attachment H. Where no methods are specified for a given pollutant, the methods must be approved by this Regional Water Board or the State Water Board.

² Priority Pollutants as defined by the California Toxics Rule (CTR) defined in Finding II.I of the Limitations and Discharge Requirements of this Order, and included as Attachment G.

B. Monitoring Location – RSW-002

1. The Discharger shall monitor the Trifolium Drain No. 6 at RSW-002 as follows. In the event that no receiving water is present at RWS-002, no receiving water monitoring data are required for station RSW-002.

Table E-7. Receiving Water Monitoring RSW-002

Parameter	Units	Sample Type	Minimum Sampling Frequency	Required Analytical Test Method
Dissolved Oxygen	mg/L	Grab	1xQuarter	See Footnote 1
pH (Hydrogen Ion)	pH Units	Grab	1xQuarter	See Footnote 1
Temperature	°F	Grab	1xQuarter	See Footnote 1
Total Dissolved Solids	mg/L	Grab	1xQuarter	See Footnote 1

¹ Pollutants shall be analyzed using the analytical methods described in 40 CFR Part 136; for priority pollutants the methods must meet the lowest minimum levels (MLs) specified in Attachment 4 of the SIP, included as Attachment H. Where no methods are specified for a given pollutant, the methods must be approved by this Regional Water Board or the State Water Board.

C. VISUAL MONITORING UPSTREAM AND DOWNSTREAM RECEIVING WATER SAMPLING POINTS

1. In conducting the receiving water sampling, a log shall be kept of the receiving water conditions at Stations RSW-001 and RSW-002. In the event that no receiving water is present at station RSW-001, no receiving water monitoring data is required for station RSW-001. Notes on receiving water conditions shall be summarized in the monitoring report. Attention shall be given to the presence or absence of:
 - a. Floating or suspended matter;
 - b. Discoloration;
 - c. Aquatic life (including plants, fish, shellfish, birds);
 - d. Visible film, sheen or coating;
 - e. Fungi, slime, or objectionable growths; and
 - f. Potential nuisance conditions.

IX. OTHER MONITORING REQUIREMENTS

A. WATER SUPPLY MONITORING

The Discharger is required to obtain or acquire quarterly total dissolved solids concentrations of the source water, either through monitoring or obtaining the data from the drinking water purveyor. This information will be compiled and summarized in a report, in accordance with Provision VI.C.2.e of the Order.

B. MONITORING LOCATION SLD-001

1. Sludge that is generated at the treatment facility shall be sampled and analyzed for the following prior to disposal:

Table E-8. Sludge Monitoring SLD-001

Constituent	Units	Sample Type	Minimum Sampling Frequency	Required Analytical Test Method
Arsenic	mg/kg	Grab	1x/Year	See Footnote 1
Cadmium	mg/kg	Grab	1x/Year	See Footnote 1
Copper	mg/kg	Grab	1x/Year	See Footnote 1
Lead	mg/kg	Grab	1x/Year	See Footnote 1
Mercury	mg/kg	Grab	1x/Year	See Footnote 1
Molybdenum	mg/kg	Grab	1x/Year	See Footnote 1
Nickel	mg/kg	Grab	1x/Year	See Footnote 1
Selenium	mg/kg	Grab	1x/Year	See Footnote 1
Zinc	mg/kg	Grab	1x/Year	See Footnote 1
Fecal Coliform	MPN/gram	Grab	1x/Year	See Footnote 1

¹ Pollutants shall be analyzed using the analytical methods described in 40 CFR Part 503.

2. The Discharger shall report annually on the quantity, location and method of disposal of all sludge and similar solid materials being produced at the wastewater treatment plant.

C. PRETREATMENT MONITORING – NOT APPLICABLE

D. MONITORING LOCATION INT-001

Visual Monitoring of Unit Processes:

1. The Discharger shall maintain a log summarizing the visual observations for Stations INT-001. The log book shall be readily available for inspection by regulatory representatives upon request. The Discharger shall record daily visual observations for each unit process and shall pay particular attention to the following:
 - a) Freeboard depth
 - b) Scum/Foam
 - c) Oil/Sheen

X. REPORTING REQUIREMENTS

A. GENERAL MONITORING AND REPORTING REQUIREMENTS

1. The Discharger shall comply with all Standard Provisions (Attachment D) related to monitoring, reporting, and recordkeeping.
2. The Discharger shall report the results of acute and chronic toxicity testing, TRE and TIE as required in section V, “Whole Effluent Toxicity Testing Requirements”.

3. The results of any analysis taken, more frequently than required using analytical methods, monitoring procedures and performed at the locations specified in this MRP shall be reported to the Regional Water Board.

B. SELF MONITORING REPORTS (SMRS)

1. At any time during the term of this permit, the State or Regional Water Board may notify the Discharger to electronically submit Self-Monitoring Reports (SMRs) using the State Water Board's California Integrated Water Quality System (CIWQS) Program Web site (<http://www.waterboards.ca.gov/ciwqs/index.html>). Until such notification is given, the Discharger shall submit hard copy SMRs. The CIWQS Web site will provide additional directions for SMR submittal in the event there will be service interruption for electronic submittal.
2. The Discharger shall report in the SMR the results for all monitoring specified in this MRP under sections III through IX. The Discharger shall submit monthly, quarterly, and an annual SMR(s) including the results of all required monitoring using USEPA-approved test methods or other test methods specified in this Order. If the Discharger monitors any pollutant more frequently than required by this Order, the results of this monitoring shall be included in the calculations and reporting of the data submitted in the SMR.
3. Monitoring periods and reporting for all required monitoring shall be completed according to the following schedule shown in Table E-9:

Table E-9. Monitoring Periods and Reporting Schedule

Sampling Frequency	Monitoring Period Begins On	Monitoring Period	SMR Due Date
Continuous	September 19, 2007	All	First day of second month following month of sampling
1x/Day	September 19, 2007	(Midnight through 11:59 PM) or any 24-hour period that reasonably represents a calendar day for purposes of sampling.	First day of second month following month of sampling
5x/Month	October 1, 2007	1 st day of calendar month through the last day of calendar month	First day of second month following month of sampling
1x/Week	September 23, 2007	Sunday through Saturday	First day of second month following month of sampling
1x/Month	October 1, 2007	1 st day of calendar month through last day of calendar month	First day of second month following month of sampling
1x/Quarter	October 1, 2007	January 1 through March 31 April 1 through June 30 July 1 through September 30 October 1 through December 31	First day of second month following the monitoring period
1x/Year	September 19, 2007	January 1 through December 31	First day of second month following the monitoring period

4. Reporting Protocols. The Discharger shall report with each sample result the applicable Reporting Level (RL) and the current Method Detection Limit (MDL), as determined by the procedure in Part 136.

The Discharger shall report the results of analytical determinations for the presence of chemical constituents in a sample using the following reporting protocols:

- a. Sample results greater than or equal to the RL shall be reported as measured by the laboratory (i.e., the measured chemical concentration in the sample).
- b. Sample results less than the RL, but greater than or equal to the laboratory's MDL, shall be reported as "Detected, but Not Quantified," or DNQ. The estimated chemical concentration of the sample shall also be reported.

For the purposes of data collection, the laboratory shall write the estimated chemical concentration next to DNQ as well as the words "Estimated Concentration" (may be shortened to "Est. Conc."). The laboratory may, if such information is available, include numerical estimates of the data quality for the reported result. Numerical estimates of data quality may be percent accuracy (\pm a percentage of the reported value), numerical ranges (low to high), or any other means considered appropriate by the laboratory.

- c. Sample results less than the laboratory's MDL shall be reported as "Not Detected," or ND.

- d. Dischargers are to instruct laboratories to establish calibration standards so that the ML value (or its equivalent if there is differential treatment of samples relative to calibration standards) is the lowest calibration standard. At no time is the Discharger to use analytical data derived from *extrapolation* beyond the lowest point of the calibration curve.
5. Multiple Sample Data. If the permit contains an AMEL for a priority pollutant and more than one sample result is available for the pollutant, the Discharger shall report the arithmetic mean unless the data set contains one or more reported determinations of DNQ or ND. In those cases, the Discharger shall report the median in place of the arithmetic mean in accordance with the following procedure:
- a. The data set shall be ranked from low to high, ranking the reported ND determinations lowest, DNQ determinations next, followed by quantified values (if any). The order of the individual ND or DNQ determinations is unimportant.
 - b. The median value of the data set shall be determined. If the data set has an odd number of data points, then the median is the middle value. If the data set has an even number of data points, then the median is the average of the two values around the middle unless one or both of the points are ND or DNQ, in which case the median value shall be the lower of the two data points where DNQ is lower than a value and ND is lower than DNQ.
6. The Discharger shall submit SMRs in accordance with the following requirements:
- a. The Discharger shall arrange all reported data in a tabular format. The data shall be summarized to clearly illustrate whether the facility is operating in compliance with interim and/or final effluent limitations. The Discharger is not required to duplicate the submittal of data that is entered in a tabular format within CIWQS. When electronic submittal of data is required and CIWQS does not provide for entry into a tabular format within the system, the Discharger shall electronically submit the data in a tabular format as an attachment.
 - b. The Discharger shall attach a cover letter to the SMR. The information contained in the cover letter shall clearly identify violations of the WDRs; discuss corrective actions taken or planned; and the proposed time schedule for corrective actions. Identified violations must include a description of the requirement that was violated and a description of the violation.
 - c. SMRs must be submitted to the Regional Water Board, signed and certified as required by the Standard Provisions (Attachment D), to the address listed below in Table E-10:

Table E-10. Self-Monitoring Report – Mailing Address

Standard Mail/FedEx/UPS/Other Private Carriers
California Regional Water Quality Control Board Colorado River Basin Region 73-720 Fred Waring, Suite 100 Palm Desert, CA 92260

C. DISCHARGE MONITORING REPORTS (DMRS)

1. As described in Section X.B.1 above, at any time during the term of this permit, the State or Regional Water Board may notify the Discharger to electronically submit SMRs that will satisfy federal requirements for submittal of Discharge Monitoring Reports (DMRs). Until such notification is given, the Discharger shall submit DMRs in accordance with the requirements described below.
2. DMRs must be signed and certified as required by the standard provisions (Attachment D). The Discharge shall submit the original DMR and one copy of the DMR to the address listed in Table E-11 below:

Table E-11. Discharge Monitoring Reports – Mailing Addresses

STANDARD MAIL	FEDEX/UPS/ OTHER PRIVATE CARRIERS
State Water Resources Control Board Division of Water Quality c/o DMR Processing Center PO Box 100 Sacramento, CA 95812-1000	State Water Resources Control Board Division of Water Quality c/o DMR Processing Center 1001 I Street, 15 th Floor Sacramento, CA 95814

3. All discharge monitoring results must be reported on the official USEPA pre-printed DMR forms (EPA Form 3320-1). Forms that are self-generated or modified cannot be accepted.

D. OTHER REPORTS

1. The Discharger shall report the results of any special studies, compliance reports, acute and chronic toxicity testing, TRE/TIE, and Pollution Prevention Plans required under the Special Provisions – VI.C of this Order. The Discharger shall report the progress in satisfaction of compliance schedule dates specified in Special Provisions – VI.C of this Order. The Discharger shall submit reports with the first monthly SMR scheduled to be submitted on or immediately following the report due date, or February 1 for annual reports, in compliance with SMR reporting requirements described in subsection X.B.6 above.
2. **Operations and Maintenance Report.** The Discharger shall report the following as shown in Table E-12:

Table E-12. Operations and Maintenance Report

Activity	Reporting Frequency
The amount of chemical used (i.e., chlorine, sulfur dioxide, etc.,) shall be monitored daily and reported monthly. Measured in pounds per day.	1x/Month
To inspect and document any operation/maintenance problems by inspecting each unit process. In addition, calibration of flow meters and mechanical equipment shall be performed in a timely manner and documented.	1x/Year

3. **Septage Haulers Waste Log.** The Discharger shall maintain records of sources of disposal waste brought to the Facility by septage haulers (i.e., wastes from septic tank and portable toilet facilities). The Discharger currently maintains a record of wastes received and shall continue maintaining such records. The Discharger shall obtain information including the date, time, volume of waste discharged, vehicle license number, and source of waste. The Discharger is not required to report this information to the Regional Water Board; however, is required to maintain the Manifest on-site and available for inspection.

ATTACHMENT F – FACT SHEET

Table of Contents

Attachment F – Fact Sheet F-3

I. Permit Information..... F-3

II. Facility Description F-4

 A. Description of Wastewater and Biosolids Treatment or Controls F-4

 B. Discharge Points and Receiving Waters F-5

 C. Summary of Existing Requirements and Self-Monitoring Report (SMR) Data F-5

 D. Compliance Summary F-7

 E. Planned Changes F-8

III. Applicable Plans, Policies, and Regulations F-8

 A. Legal Authorities F-8

 B. California Environmental Quality Act (CEQA)..... F-8

 C. State and Federal Regulations, Policies, and Plans F-8

 D. Impaired Water Bodies on CWA 303(d) List..... F-8

 E. Other Plans, Policies and Regulations F-8

IV. Rationale For Effluent Limitations and Discharge Specifications F-8

 A. Discharge Prohibitions F-8

 B. Technology-Based Effluent Limitations F-8

 1. Scope and Authority F-8

 2. Applicable Technology-Based Effluent Limitations..... F-8

 C. Water Quality-Based Effluent Limitations (WQBELs) F-8

 1. Scope and Authority F-8

 2. Applicable Beneficial Uses and Water Quality Criteria and Objectives..... F-8

 3. Determining the Need for WQBELs F-8

 4. WQBEL Calculations F-8

 5. Whole Effluent Toxicity (WET) F-8

 D. Final Effluent Limitations..... F-8

 1. Mass-based Effluent Limitations F-8

 2. Final Effluent Limitations..... F-8

 3. Satisfaction of Anti-Backsliding Requirements..... F-8

 4. Satisfaction of Anti-degradation Policy..... F-8

 5. Stringency of Requirements for Individual Pollutants F-8

 E. Interim Effluent Limitations..... F-8

 F. Land Discharge Specifications – Not Applicable F-8

 G. Reclamation Specifications – Not Applicable F-8

V. Rationale for Receiving Water Limitations F-8

 A. Surface Water..... F-8

 B. Groundwater – Not Applicable F-8

VI. Rationale for Monitoring and Reporting Requirements F-8

 A. Influent Monitoring F-8

 B. Effluent Monitoring F-8

 C. Whole Effluent Toxicity Testing Requirements..... F-8

 D. Receiving Water Monitoring..... F-8

 1. Surface Water F-8

 2. Groundwater – Not Applicable F-8

E.	Other Monitoring Requirements	F-8
1.	Water Supply Monitoring	F-8
2.	Biosolids/Sludge Monitoring.....	F-8
VII.	Rationale for Provisions	F-8
A.	Standard Provisions	F-8
B.	Special Provisions.....	F-8
1.	Reopener Provisions	F-8
2.	Special Studies and Additional Monitoring Requirements	F-8
3.	Best Management Practices and Pollution Prevention.....	F-8
4.	Construction, Operation, and Maintenance Specifications.....	F-8
5.	Special Provisions for Municipal Facilities (POTWs Only).....	F-8
6.	Other Special Provisions	F-8
7.	Compliance Schedules	F-8
VIII.	Public Participation.....	F-8
A.	Notification of Interested Parties	F-8
B.	Written Comments	F-8
C.	Public Hearing	F-8
D.	Waste Discharge Requirements Petitions	F-8
E.	Information and Copying.....	F-8
F.	Register of Interested Persons.....	F-8
G.	Additional Information	F-8

List of Tables

Table F-1.	Facility Information.....	F-3
Table F-2.	Historic Effluent Limitations and Monitoring Data	F-5
Table F-3.	Effluent Characteristics	F-7
Table F-4.	Compliance Summary.....	F-7
Table F-5.	Basin Plan Beneficial Uses	F-8
Table F-6.	Summary of Technology-based Effluent Limitations	F-8
Table F-7.	Basis for Limitations.....	F-8
Table F-8.	Applicable Beneficial Uses and Water Quality Criteria and Objectives.....	F-8
Table F-9.	Summary of Reasonable Potential Analysis.....	F-8
Table F-10.	Summary of Water Quality-based Effluent Limitations	F-8
Table F-11.	Summary of Final Effluent Limitations.....	F-8
Table F-12.	Interim Effluent Limitations.....	F-8

ATTACHMENT F – FACT SHEET

As described in section II of this Order, this Fact Sheet includes the legal requirements and technical rationale that serve as the basis for the requirements of this Order.

This Order has been prepared under a standardized format to accommodate a broad range of discharge requirements for Dischargers in California. Only those sections or subsections of this Order that are specifically identified as “not applicable” have been determined not to apply to this Discharger. Sections or subsections of this Order not specifically identified as “not applicable” are fully applicable to this Discharger.

I. PERMIT INFORMATION

The following table summarizes administrative information related to the facility.

Table F-1. Facility Information

WDID	7A 13 0112 012
Discharger	City of Westmorland
Name of Facility	City of Westmorland Wastewater Treatment Plant
Facility Address	5305 Martin Road
	Westmorland, CA 92281
	Imperial County
Facility Contact, Title and Phone	Lucas G. Agatep, Chief Operator (760) 344-0146
Authorized Person to Sign and Submit Reports	Henry Graham, City Mayor (760) 344-3411
Mailing Address	P.O. Box 699 Westmorland, CA 92281
Billing Address	SAME
Type of Facility	Publicly Owned Treatment Works (POTW)
Major or Minor Facility	Minor
Threat to Water Quality	2
Complexity	B
Pretreatment Program	N
Reclamation Requirements	None
Facility Permitted Flow	0.50 million gallons per day (MGD)
Facility Design Flow	0.50 MGD
Watershed	Imperial Hydrologic Unit
Receiving Water	Trifolium Drain No. 6
Receiving Water Type	Drain

- A. The City of Westmorland (hereinafter Discharger) is the owner and operator of City of Westmorland Wastewater Treatment Plant (as per permit renewal) (hereinafter Facility), a publicly owned treatment works (POTW).

For the purposes of this Order, references to “discharger” or “permittee” in applicable federal and state laws, regulations, plans, or policy are held to be equivalent to references to the Discharger herein.

- B. The Facility discharges wastewater to Trifolium Drain No. 6, which discharges to the New River, a water of the United States, and is currently regulated by Order R7-2002-0004 which was adopted on January 16, 2002 and expired on January 16, 2007. The terms and conditions of the current Order have been automatically continued and remain in effect until new WDRs and NPDES permit are adopted pursuant to this Order.
- C. The Discharger filed a ROWD and submitted an application for renewal of its WDRs and NPDES permit on September 26, 2006. Supplemental information was requested on January 4, 2007. In response, the Board received a request from the Discharger on January 26, 2007 for a 30-day extension to submit the information required to finalize the processing of the City's renewal application. This information was received on March 13, 2007. A site visit was conducted on November 29, 2006, to observe operations and collect additional data to develop permit limitations and conditions.

II. FACILITY DESCRIPTION

The Discharger owns and operates a wastewater collection, treatment and disposal system (hereinafter referred to as the Facility) and provides sewerage service to a population of 2,400 located in the City of Westmorland which is located in the Imperial Valley, south of the Salton Sea. The wastewater treatment plant has a treatment capacity of 0.5 MGD and is located in SW ¼ of Section 4, T13S, R13E, SBB&M.

A. DESCRIPTION OF WASTEWATER AND BIOSOLIDS TREATMENT OR CONTROLS

The treatment system consists of a sewage receiving area and pump station, an influent flow meter, an oxidation ditch, two 28-foot clarifiers, chlorine contact chambers, dechlorination operations and constructed wetlands. The Discharger may divert all of the chlorinated effluent flow, a portion of, or no flow to the constructed wetlands prior to the discharge to Trifolium Drain No. 6. The effluent is chlorinated using gaseous chlorine and dechlorinated prior to flowing to the wetlands. The unlined constructed wetland ponds are currently regulated by Order No. R7-2005-0062 for discharges to groundwater.

The constructed wetlands consist of two, 2-acre unlined wetland ponds which became operational on January 1, 2007. The two, unlined wetland ponds operate in parallel. The wetlands have a series of deep open water and shallow emergent vegetated sections, which include bulrush, cattail and other wetland native plant species. Effluent from the two wetlands is joined into a single pipe that flows by gravity back to the main outfall pipe prior to the discharge to Discharge Point 001 (see table on cover page) to Trifolium Drain No. 6, and then discharged to the New River, a water of the United States, about 8 miles from the Salton Sea, within Colorado River Basin.

The facility also includes sludge drying beds.

Based on the data provided by the Discharger for the previous permit term, the maximum average daily discharge to the receiving waters was 0.215 million gallons per day (MGD) and the facility generated 50 dry metric tons of sludge during which was removed and disposed of at the La Paz County Landfill.

B. DISCHARGE POINTS AND RECEIVING WATERS

Wastewater is discharged into Trifolium Drain No. 6, Latitude 33° 02' 45" North; Longitude 115° 37' 44" West. Discharged water flows through Trifolium Drain No. 6 for approximately 3.5 miles before entering the New River, approximately 8 miles from the Salton Sea. All wastewater discharged from this Facility is discharged through Discharge Point 001. The discharge consists of secondary treated domestic wastewater.

C. SUMMARY OF EXISTING REQUIREMENTS AND SELF-MONITORING REPORT (SMR) DATA

Effluent limitations contained in the existing Order for discharges from Discharge Point 001 (Monitoring Point EFF-001) and representative monitoring data from the term of the previous Order are as shown in Table F-2:

Table F-2. Historic Effluent Limitations and Monitoring Data

Parameter	Units	Effluent Limitation				Monitoring Data (From November 2001 To July 2006)			
		Average Monthly	Average Weekly	Log ¹ Mean	Maximum Daily	Highest Average Monthly Discharge	Highest Average Weekly Discharge	Log ¹ Mean	Highest Daily Discharge
Biochemical Oxygen Demand (BOD) (5-day @ 20 Deg. C)	mg/L	30	45	---	---	8	13	---	---
Removal Efficiency for BOD ₅ (30-Day)	%	85	---	---	---	97.7 ²	---	---	---
pH	pH Units	---	---	---	6.0 - 9.0	---	6.25 – 7.86 ³	---	---
Total Suspended Solids (TSS)	mg/L	30	45	---	---	10.8	16	---	---
Removal Efficiency for TSS (30-Day)	%	85	---	---	---	95.7 ²	---	---	---

Parameter	Units	Effluent Limitation				Monitoring Data (From November 2001 To July 2006)			
		Average Monthly	Average Weekly	Log ¹ Mean	Maximum Daily	Highest Average Monthly Discharge	Highest Average Weekly Discharge	Log ¹ Mean	Highest Daily Discharge
Chlorine, Total Residual	mg/L	0.01	---	---	0.02 ⁴	0.01	---	---	0.14
Escherichia Coli (E. Coli) ⁵	MPN/100ml	---	---	126 ⁶	400	---	---	207	16,000
Total Dissolved Solids (TDS)	mg/L	4,000	4,500	---	---	1,939	2,520	---	---

“---”No effluent limitation is applicable.

¹ The log mean of the Most Probable Number (MPN) is based on a minimum of not less than five (5) samples for any 30-day period.

² This value represents the lowest reported value of the minimum percent removal of the pollutant

³ This represents the range of reported pH values.

⁴ The reported value is an instantaneous maximum.

⁵ Escherichia Coli limits became effective on October 1, 2002.

⁶ The reported data were based on a minimum of not less than five (5) samples for any 30-day period.

The ROWD described the existing discharge as follows:

Annual Average Effluent Flow – 0.252 MGD

Maximum Daily Effluent Flow – 0.358 MGD

The ROWD described the effluent characteristics in Table F-3 as follows:

Table F-3. Effluent Characteristics

Constituent	Units	Maximum Daily	Average Daily
pH Lowest	s.u.	6.43	---
pH Highest	s.u.	6.94	---
Temperature (Winter)	°F	18	---
Temperature (Summer)	°F	31	---
Biochemical Oxygen Demand	mg/L	4.2	3.7
Total Suspended Solids	mg/L	4.5	3.8
Fecal Coliform	MPN/100 mL	140	54
Ammonia as Nitrogen	mg/L	0.56	0.56
Total Residual Chlorine	mg/L	0.0097	0.007
Dissolved Oxygen	mg/L	4.23	3.22
Total Kjeldahl Nitrogen	mg/L	21.81	18.28
Nitrate plus Nitrite as Nitrogen	mg/L	18.4	15.01
Oil and Grease	mg/L	7	3.9
Phosphorus	mg/L	1.89	1.73
Total Dissolved Solids	mg/L	1,804	1,644

D. COMPLIANCE SUMMARY

The available effluent monitoring data and Notice of Violation (NOV) records indicate that the Discharger exceeded effluent limitations contained in Order No. R7-2002-0004 for E. Coli, total chlorine residual, and toxicity. A violation in recordkeeping was also noted.

Table F-4. Compliance Summary

Date	Violation Type	Parameter	Reported Effluent Value	Permit Limitation	Units
2/2006	Maximum	E. coli	500	400	MPN/100 ml
8/3/2005	Maximum	E. coli	1,600	400	MPN/100 ml
8/24/2005	Maximum	E. coli	1,600	400	MPN/100 ml
7/25/2005	Maximum	E. coli	900	400	MPN/100 ml
3/23/2005	Maximum	E. coli	500	400	MPN/100 ml
7/2004	Maximum	E. coli	500	400	MPN/100 ml
1/2004	Maximum	E. coli	9,000	400	MPN/100 ml
12/2003	Maximum	E. coli	1,600	400	MPN/100 ml
8/26/2003	Maximum	E. coli	16,000	400	MPN/100 ml
7/31/2005	Log Mean	E. coli	207	126	MPN/100 ml
8/31/2003	Log Mean	E. coli	158	126	MPN/100 ml
8/2003	Average Monthly	Total Chlorine Residual	0.01	0.14	mg/L

The available effluent monitoring data indicated that the Discharger did not meet the effluent limit of 90% survival for acute toxicity of *C. dubia* (i.e., water flea) twice during the permit term: 70% survival was observed on November 20, 2002 and 40% survival was observed on August 21, 2002. The NOV reported the 40% survival on September 30, 2002 instead of August 21, 2002. The available effluent monitoring data indicated that the Discharger did not meet the

effluent limit of 90% survival for acute toxicity of *P. promelas* (i.e., fathead minnow) once during the permit term: 82.5% survival was observed on March 6, 2002.

The available effluent monitoring data indicated that the Discharger did not meet the effluent limit of 80% survival for chronic toxicity of *C. dubia* (i.e., water flea) three times during the permit term: 12.5% survival was observed on January 24, 2005; 50% survival was observed on November 20, 2002 and again on August 21, 2002. The available effluent monitoring data indicated that the Discharger exceeded the chronic toxicity trigger for the survival of *C. dubia* ($Tu_c = <2$) one time ($Tu_c = 8.0$ collected on January 24, 2005). The NOV recorded the occurrence on March 31, 2005 instead of January 24, 2005.

Further, violations identified during a compliance evaluation inspection by the Regional Water Board on April 21, 2004 identified deficiencies in paperwork and recommended that a NOV be issued to request that paperwork be updated.

E. PLANNED CHANGES

During the new permit term, the Discharger will be operating constructed wetlands in conjunction with the existing treatment plant. The constructed wetlands became operational on January 1, 2007 and are currently regulated by Order No. R7-2005-0062.

III. APPLICABLE PLANS, POLICIES, AND REGULATIONS

The requirements contained in the proposed Order are based on the requirements and authorities described in this section.

A. LEGAL AUTHORITIES

This Order is issued pursuant to Section 402 of the Federal Clean Water Act (CWA) and implementing regulations adopted by the U.S. Environmental Protection Agency (USEPA) and Chapter 5.5, Division 7 of the CWC (commencing with Section 13370). It shall serve as an NPDES permit for point source discharges from this facility to surface waters. This Order also serves as WDRs pursuant to Article 4, Chapter 4, Division 7 of the Water Code (commencing with Section 13260).

B. CALIFORNIA ENVIRONMENTAL QUALITY ACT (CEQA)

Under Water Code Section 13389, this action to adopt an NPDES permit is exempt from the provisions of Chapter 3 of CEQA, commencing with Section 21100 of the Public Resources Code.

C. STATE AND FEDERAL REGULATIONS, POLICIES, AND PLANS

- 1. Water Quality Control Plans.** The Regional Water Quality Control Board (Regional Water Board) adopted a Water Quality Control Plan for the Colorado River Basin (hereinafter Basin Plan) on November 17, 1993 that designates beneficial uses, establishes water quality objectives, and contains implementation programs and policies to achieve those objectives for all waters addressed through the plan (includes amendments adopted by the Regional Water Board to date). In addition, the Basin Plan implements State Water Resources Control Board (State Water Board) Resolution No. 88-63, which established state policy that all waters, with certain exceptions, should be considered suitable or potentially suitable for municipal or domestic supply. This exception does not apply because the beneficial uses of

the receiving water are not designated as a municipal or domestic water supply. Beneficial uses applicable to Trifolium Drain No. 6, one of the Imperial Valley Drains, are as described in Table F-5:

Table F-5. Basin Plan Beneficial Uses

Discharge Point	Receiving Water Name	Beneficial Use(s)
001	Trifolium Drain (Imperial Valley Drains)	Existing: Freshwater Replenishment (FRSH); Contact (REC-1) ^{1, 2} and Non-Contact (REC-2) ¹ Water Recreation; Warm Freshwater Habitat (WARM); Wildlife Habitat (WILD); Preservation or Rare, Threatened or Endangered Species (RARE) ³ .

¹ Unauthorized Use.

² The only REC-1 usage that is known to occur is from infrequent fishing.

³ Rare, endangered, or threatened wildlife exists in or utilizes some of this waterway(s). If the RARE beneficial use may be affected by a water quality control decision, responsibility for substantiation of the existence of rare, endangered, or threatened species on a case-by-case basis is upon the California Department of Fish and Game on its own initiative and/or at the request of the Regional Water Board; and such substantiation must be provided within a reasonable time frame as approved by the Regional Water Board.

Requirements of this Order implement the Basin Plan.

2. **Thermal Plan.** The State Water Board adopted a *Water Quality Control Plan for Control of Temperature in the Coastal and Interstate Waters and Enclosed Bays and Estuaries of California* (Thermal Plan) on May 18, 1972, and amended this plan on September 18, 1975. This plan contains temperature objectives for surface waters. The Thermal Plan does not apply to Trifolium Drain No. 6 or the New River.
3. **National Toxics Rule (NTR) and California Toxics Rule (CTR).** USEPA adopted the NTR on December 22, 1992, and later amended it on May 4, 1995 and November 9, 1999. About forty criteria in the NTR applied in California. On May 18, 2000, USEPA adopted the CTR. The CTR promulgated new toxics criteria for California and, in addition, incorporated the previously adopted NTR criteria that were applicable in the state. The CTR was amended on February 13, 2001. These rules contain water quality criteria for priority pollutants.
4. **State Implementation Policy.** On March 2, 2000, the State Water Board adopted the *Policy for Implementation of Toxics Standards for Inland Surface Waters, Enclosed Bays, and Estuaries of California* (State Implementation Policy or SIP). The SIP became effective on April 28, 2000 with respect to the priority pollutant criteria promulgated for California by the USEPA through the NTR and to the priority pollutant objectives established by the Regional Water Board in the Basin Plan. The SIP became effective on May 18, 2000 with respect to the priority pollutant criteria promulgated by the USEPA through the CTR. The State Water Board adopted amendments to the SIP on February 24, 2005 that became effective on July 13, 2005. The SIP establishes implementation provisions for priority pollutant criteria and objectives and provisions for chronic toxicity control. Requirements of this Order implement the SIP.

5. **Emergency Planning and Community Right to Know Act.** Section 13263.6(a), CWC, requires that “the Regional Water Board shall prescribe effluent limitations as part of the WDRs of a POTW for all substances that the most recent toxic chemical release data reported to the state emergency response commission pursuant to Section 313 of the Emergency Planning and Community Right to Know Act of 1986 (42 U.S.C. Sec. 11023) (EPCRA) indicate as discharged into the POTW, for which the State Water Board or the Regional Water Board has established numeric water quality objectives, and has determined that the discharge is or may be discharged at a level which will cause, have the reasonable potential to cause, or contribute to, an excursion above any numeric water quality objective.”
6. **Storm Water Requirements.** USEPA promulgated Federal Regulations for storm water on November 16, 1990 in 40 CFR Parts 122, 123, and 124. The NPDES Industrial Storm Water Program regulates storm water discharges from wastewater treatment facilities. Wastewater treatment plants are applicable industries under the storm water program and are obligated to comply with the Federal Regulations.
7. **Endangered Species Act.** This Order does not authorize any act that results in the taking of a threatened or endangered species or any act that is now prohibited, or becomes prohibited in the future, under either the California Endangered Species Act (California Fish and Game Code Sections 2050 to 2097) or the Federal Endangered Species Act (16 U.S.C.A. Sections 1531 to 1544). This Order requires compliance with effluent limits, receiving water limits, and other requirements to protect the beneficial uses of waters of the state. The Discharger is responsible for meeting all requirements of the applicable Endangered Species Act
8. **Alaska Rule.** On March 30, 2000, USEPA revised its regulation that specifies when new and revised state and tribal water quality standards (WQS) become effective for CWA purposes (40 C.F.R. § 131.21, 65 Fed. Reg. 24641 (April 27, 2000)). Under the revised regulation (also known as the Alaska rule), new and revised standards submitted to USEPA after May 30, 2000, must be approved by USEPA before being used for CWA purposes. The final rule also provides that standards already in effect and submitted to USEPA by May 30, 2000, may be used for CWA purposes, whether or not approved by USEPA.
9. **Stringency of Requirements for Individual Pollutants.** This Order contains both technology-based and water quality-based effluent limitations for individual pollutants. The technology-based effluent limitations consist of restrictions on BOD₅, TSS, pH and percent removal of BOD and TSS. Restrictions on BOD₅, TSS, pH and percent removal of BOD and TSS are discussed in section IV.B.2 of the Fact Sheet. This Order’s technology-based pollutant restrictions implement the minimum, applicable federal technology-based requirements. These limitations are no more stringent than required by the CWA. Water quality-based effluent limitations have been scientifically derived to implement water quality objectives that protect beneficial uses. Both the beneficial uses and the water quality objectives have been approved pursuant to federal law and are the applicable federal water quality standards. To the extent that toxic pollutant water quality-based effluent limitations were derived from the CTR, the CTR is the applicable standard pursuant to Title 40, CFR Section 131.38.¹ The scientific procedures for calculating the individual water quality-based effluent limitations are based on the CTR-SIP, which was approved by USEPA on May 18, 2000. All beneficial uses and water quality objectives contained in the Basin Plan were approved under State law and submitted to and approved by USEPA prior to May 30, 2000.

¹ All further statutory references are to title 40 of the CFR unless otherwise indicated.

Any water quality objectives and beneficial uses submitted to USEPA prior to May 30, 2000, but not approved by USEPA before that date, are nonetheless “applicable water quality standards for purposes of the CWA” pursuant to Section 131.21(c)(1). Collectively, this Order’s restrictions on individual pollutants are no more stringent than required to implement the requirements of the CWA.

- 10. Anti-degradation Policy.** Section 131.12 requires that the state water quality standards include an anti-degradation policy consistent with the federal policy. The State Water Board established California’s anti-degradation policy in State Water Board Resolution No. 68-16. Resolution No. 68-16 incorporates the federal anti-degradation policy where the federal policy applies under federal law. Resolution No. 68-16 requires that existing quality of waters be maintained unless degradation is justified based on specific findings.

The source water for the City of Westmorland and the entire Imperial Valley is the Colorado River. Average annual precipitation in the Imperial Valley is insignificant (~ 2 inches/year). Therefore, the Trifolium Drain No. 6 is an effluent dominated surface water that exclusively carries the discharge from the Discharger’s WWTP and agricultural returns flows in the form of tilewater, tailwater and occasionally operational spills of irrigation water from adjacent farmlands. Tailwater is irrigation water that does not percolate into the soil, and exits the lower end of the field into the drain. Tailwater tends to erode fields and thus acquire silt and sediments as it crosses and exits a field. Tilewater is water that has percolated through the soil, but is not absorbed by crops. Tilewater flushes salts from the soil. This highly saline water accumulates in tile lines beneath the fields, wherein it is transported to drains by gravity flow or a sump system. Consequently, “background” water quality in the drain is difficult to establish for the purpose of conducting a typical antidegradation analysis. In other words, it is very likely that the Trifolium Drain No. 6 has historically contained “background” water from farmland that contains pollutants at concentrations that violate certain Basin Plan water quality objectives for those pollutants—in particular pesticides, silt/sediment², and selenium as discussed in Finding No. H of this permit. They also contain nutrients (e.g., phosphorous) at concentrations that contribute to the nutrient impairment of the Salton Sea, but the agricultural return flows are essentially free of BOD and fecal coliform bacteria and have pH well within the receiving water quality objective of 6.0 to 9.0 pH Units.

The discharge from the WWTP contains conventional pollutants (BOD, TSS, fecal coliform bacteria and pH) that are controlled through best practicable control technology currently available (BPT) and best available technology economically achievable (BCT) to prevent exceedance of the receiving water quality objectives for those pollutants and prevent adverse impacts on the REC I and REC II beneficial uses of the Drain. The discharge also contains TDS, but at a concentration significantly below the 4000 mg/L TDS WQO for the receiving water. Except for selenium, the discharge from the WWTP does not contain any of the 303(d) List impairing pollutants for the receiving water at detectable levels. Therefore, except for selenium, the discharge is not likely to contribute to exceedances of the WQOs for 303(d) pollutants. Selenium has been found in the WWTP effluent at a Maximum Effluent Concentration (MEC) of 3.2 ug/L, which is below the receiving water quality objective of 5 ug/L. Although the effluent discharge exhibits reasonable potential to contribute to violation of the WQO for selenium as the maximum detected upstream receiving water concentration (B) for Trifolium Drain No. 6 exceeds the WQO for selenium, therefore a WQBEL for selenium was derived from water quality criteria established in the CTR. The discharge also contains copper which is being controlled through a WQBEL

² Silt/sediment can be measured in terms of TSS.

derived from water quality criteria established in the CTR. The established WQBELs for copper and selenium prevent adverse impacts of the WARM, WILD, and RARE beneficial uses of the Drain and ensure compliance with the Basin Plan narrative water quality objective for metals (see Basin Plan, Ch 3, Item N, p. 4). Further, in the case of copper, the Order establishes interim effluent limitations that are effective from September 19, 2007 to May 18, 2010 and final WQBELs effective thereafter. The Discharger is required to submit an Infeasibility Report to the Regional Water Board by October 19, 2007 that documents efforts the Discharger has made to quantify pollutant levels, document source control and pollutant minimization efforts, propose a schedule for additional source control measures and demonstrate that the proposed schedule is as short as possible. The Discharger is also required to submit a Compliance Plan within one year of adoption of the Order that identifies the measures that will be taken to achieve compliance with the permit limitations specified in Effluent Limitations, IV.A.1.a. of this Order. Nevertheless, the BOD, TSS, bacteria, selenium, and copper in the discharge are likely to lower water quality in the receiving water (i.e., cause degradation). For conventional pollutants, including BOD, TSS and bacteria, this degradation is restricted to pollutants associated with domestic wastewater, is localized and will not result in water quality less than that prescribed in the Basin Plan. For toxic pollutants, including Copper and Selenium, this degradation will be not significant once controlled and will not result in water quality less than prescribed in the Basin Plan.

The discharge from the WWTP as permitted herein reflects best practicable treatment and control (BPTC) for the subject wastewater. The control is intended to assure that the discharge does not create a condition of pollution or nuisance and that the highest "background" water quality as defined above will be maintained. The WWTP incorporates:

- a. technology for secondary treated domestic wastewater;
- b. sludge handling facilities;
- c. an operation and maintenance manual;
- d. staffing to assure proper operation and maintenance; and
- e. a standby emergency power generator of sufficient size to operate the necessary treatment units during periods of loss of commercial power.

The discharge is necessary to accommodate economic development in the area and essential public services to the City of Westmorland, which are a benefit to the State. Based on the foregoing, the discharge as permitted herein is consistent with Resolution No. 68-16

- 11. Anti-Backsliding Requirements.** Sections 402(o)(2) and 303(d)(4) of the CWA and federal regulations at Title 40, CFR Section 122.44(l) prohibit backsliding in NPDES permits. These anti-backsliding provisions require that effluent limitations in a reissued permit must be as stringent as those in the previous permit, with some exceptions in which limitations may be relaxed.

D. IMPAIRED WATER BODIES ON CWA 303(D) LIST

The immediate receiving water is the Trifolium Drain No. 6, which is a part of the Imperial Valley Drains. The 2006 USEPA 303(d) list of impaired waters (hereinafter 303(d) List) classifies the Imperial Valley Drains as impaired by sediment/silt, pesticides, dieldrin, DDT, endosulfan, PCBs, toxaphene and selenium. A sedimentation/siltation Total Maximum Daily Load (TMDL) for the Imperial Valley Drains has been approved by USEPA. The sedimentation/siltation TMDL has established a WLA for sediment. The established Total Suspended Solids effluent limitations in this Order comply with the WLA for sediment established in the Imperial Valley Drains sedimentation/siltation TMDL. Further, the New River, to which the Trifolium Drain No. 6

is tributary, is listed as impaired by 1,2,4-trimethylbenzene, chlordane, chloroform, chlorpyrifos, DDT, diazinon, dieldrin, mercury, meta-para xylenes, nutrients, dissolved oxygen, o-xylenes, PCBs, p-cymene, p-dichlorobenzene, pesticides, selenium, toluene, toxaphene, toxicity, copper and trash. A pathogen and sedimentation/siltation TMDL have been approved by USEPA for the New River and are implemented in this Order. The pathogen and sedimentation/siltation TMDL's established WLA's for fecal coliform, *E. Coli*, enterococci and sediment. The established fecal coliform, *E. Coli*, enterococci and total suspended solids effluent limitations in this Order comply with the WLA's established in the New River pathogen and sedimentation/siltation TMDLs. Further, there are two TMDLs under development for dissolved oxygen and VOCs for the New River. A Trash TMDL for the New River has been approved by the Regional Water Board and State Water Board and is in the process of being approved by the Office of Administrative Law and the USEPA. In addition, the 303(d) List classifies the Salton Sea as impaired by nutrients, salt and selenium. Tributaries to the Salton Sea, including the New River, may be affected by the development of TMDLs for the New River. No TMDL has been developed to date for the Salton Sea, although a nutrient TMDL is under development for the Salton Sea that may impact the permitted discharges to tributaries to the Salton Sea (New River). The nutrient TMDL for the Salton Sea is tentatively scheduled for completion in 2009.

E. OTHER PLANS, POLICES AND REGULATIONS

Federal regulations for storm water discharges require specific categories of facilities, which discharge storm water associated with industrial activity (storm water), to obtain NPDES permits and to implement Best Conventional Pollutant Technology (BCT) and Best Available Technology Economically Achievable (BAT) to reduce or eliminate industrial storm water pollution.

The State Water Board adopted Order No. 97-03-DWQ (General Permit No. CAS000001), specifying WDRs for discharges of storm water associated with industrial activities, excluding construction activities, and requiring submittal of a Notice of Intent by industries to be covered under the Permit. Coverage under the General Permit is not required because there are no storm water flows from the facility. Storm water is retained on-site by berms and grading and does not discharge from the facility.

IV. RATIONALE FOR EFFLUENT LIMITATIONS AND DISCHARGE SPECIFICATIONS

The CWA requires point source dischargers to control the amount of conventional, non-conventional, and toxic pollutants that are discharged into the waters of the United States. The control of pollutants discharged is established through effluent limitations and other requirements in NPDES permits. There are two principal bases for effluent limitations in Title 40 of the CFR: Section 122.44(a) requires that permits include applicable technology-based limitations and standards; and Section 122.44(d) requires that permits include water quality-based effluent limitations to attain and maintain applicable numeric and narrative water quality criteria to protect the beneficial uses of the receiving water. Where reasonable potential has been established for a pollutant, but there is no numeric criterion or objective for the pollutant, water quality-based effluent limitations (WQBELs) may be established: (1) using USEPA criteria guidance under CWA Section 304(a), supplemented where necessary by other relevant information; (2) on an indicator parameter for the pollutant of concern; or (3) using a calculated numeric water quality criterion, such as a proposed state criterion or policy interpreting the state's narrative criterion, supplemented with other relevant information, as provided in Section 122.44(d)(1)(vi).

Effluent and receiving water limitations in this Order are based on the federal CWA, Basin Plan, State Water Board's plans and policies, USEPA guidance and regulations, and best practicable waste treatment technology. While developing effluent limitations and receiving water limitations, monitoring requirements, and special conditions for the draft permit, the following information sources were used:

1. USEPA NPDES Application Forms 1, 2A, and 2S dated March 13, 2007.
2. CFR – Title 40
3. Water Quality Control Plan (Colorado River Basin – Region 7) as amended to date.
4. Regional Water Board files related to City of Westmorland Wastewater Treatment Plant NPDES permit CA0105007

A. DISCHARGE PROHIBITIONS

Effluent and receiving water limitations in this Order are based on the Federal CWA, Basin Plan, State Water Board's plans and policies, USEPA guidance and regulations, and best practicable waste treatment technology.

B. TECHNOLOGY-BASED EFFLUENT LIMITATIONS

1. Scope and Authority

Section 301(b) of the CWA and implementing USEPA permit regulations at section 122.44, title 40 of the CFR, require that permits include conditions meeting applicable technology-based requirements at a minimum, and any more stringent effluent limitations necessary to meet applicable water quality standards. The discharge authorized by this Order must meet minimum federal technology-based requirements based on Secondary Treatment Standards at Part 133.

- a. Secondary Treatment Standards. Regulations promulgated in 40 CFR §125.3(a)(1) require technology-based effluent limitations for municipal dischargers to be placed in NPDES permits based on Secondary Treatment Standards or Equivalent to Secondary Treatment Standards.

The Federal Water Pollution Control Act Amendments of 1972 (Public Law 92-500) established the minimum performance requirements for POTWs [defined in Section 304(d)(1)]. Section 301(b)(1)(B) of that Act requires that such treatment works must, at a minimum, meet effluent limitations based on secondary treatment as defined by the USEPA Administrator.

Based on this statutory requirement, USEPA developed secondary treatment regulations, which are specified in 40 CFR Part 133. These technology-based regulations apply to all municipal wastewater treatment plants and identify the minimum level of effluent quality attainable by secondary treatment in terms of biochemical oxygen demand (BOD₅), total suspended solids (TSS), and pH.

2. Applicable Technology-Based Effluent Limitations

- a. This facility meets the technology-based regulations for the minimum level of effluent quality attainable by secondary treatment in terms of biochemical oxygen demand (BOD₅), TSS, and pH as summarized in Table F-5. Previous Order No. R7-2002-0004 established technology-based effluent limits to meet applicable secondary treatment standards. These effluent limitations have been carried over from the previous Order. Further, mass-based effluent limitations are based on a design flow rate of 0.5 MGD.

The technology-based effluent limitations for the discharge from the treatment system through Discharge Point No. 001 at Monitoring Location EFF- 001 are summarized in Table F-6 below:

**Summary of Technology-based Effluent Limitations
 Discharge Point 001**

Table F-6. Summary of Technology-based Effluent Limitations

Parameter	Units	Effluent Limitations				
		Average Monthly	Average Weekly	Maximum Daily	Instantaneous Minimum	Instantaneous Maximum
Flow	MGD	0.5	---	---	---	---
Biochemical Oxygen Demand (BOD) (5-day @ 20 Deg. C)	mg/L	30	45	---	---	---
	lbs/day ¹	125	188	---	---	---
Total Suspended Solids (TSS)	mg/L	30	45	---	---	---
	lbs/day ¹	125	188	---	---	---
pH	pH units	---	---	---	6.0	9.0
Removal Efficiency for BOD and TSS	%	85	---	---	---	---

“---” No effluent limitation is applicable.

¹ The mass-based effluent limitations are based on a design capacity of 0.50 MGD.

b. Basis for Limitations. The basis for limitations is summarized in Table F-7 below:

Table F-7. Basis for Limitations

Constituents	Basis for Limitations
Biochemical Oxygen Demand (BOD)	Discharges to waters that support aquatic life and are dependent on oxygen. Organic matter in the discharge may consume oxygen as it breaks down.
Total Suspended Solids (TSS)	High levels of suspended solids can adversely impact aquatic habitat. Untreated or improperly treated wastewater can contain high amounts of suspended solids.
Hydrogen Ion (pH)	Hydrogen Ion (pH) is a measure of Hydrogen Ion concentration in the water. A range specified between 6.0 and 9.0 ensures suitability of biological life. This limitation has been adopted in the Basin Plan of the Region.
Flow	The design capacity of the treatment plant is currently 0.50 MGD.

C. WATER QUALITY-BASED EFFLUENT LIMITATIONS (WQBELS)

1. Scope and Authority

Section 301(b) of the CWA and Section 122.44(d) require that permits include limitations more stringent than applicable federal technology-based requirements where necessary to achieve applicable water quality standards.

Section 122.44(d)(1)(i) mandates that permits include effluent limitations for all pollutants that are or may be discharged at levels that have the reasonable potential to cause or contribute to an exceedance of a water quality standard, including numeric and narrative objectives within a standard. Where reasonable potential has been established for a pollutant, but there is no numeric criterion or objective for the pollutant, water quality-based effluent limitations (WQBELs) must be established using: (1) USEPA criteria guidance under CWA Section 304(a), supplemented where necessary by other relevant information; (2) an indicator parameter for the pollutant of concern; or (3) a calculated numeric water quality criterion, such as a proposed state criterion or policy interpreting the state’s narrative criterion, supplemented with other relevant information, as provided in Section 122.44(d)(1)(vi).

The process for determining reasonable potential and calculating WQBELs when necessary is intended to protect the designated uses of the receiving water as specified in the Basin Plan, and achieve applicable water quality objectives and criteria that are contained in other state plans and policies, or any applicable water quality criteria contained in the CTR and NTR.

2. Applicable Beneficial Uses and Water Quality Criteria and Objectives

Table F-8 summarizes the applicable water quality criteria/objectives for priority pollutants reported in detectable concentrations in the effluent or receiving water. The hardness value used to conduct the Reasonable Potential Analysis was 400 mg/L. These criteria were used in conducting the Reasonable Potential Analysis (RPA) for this Order.

Table F-8. Applicable Beneficial Uses and Water Quality Criteria and Objectives

CTR No.	Parameter	Selected Criteria	CTR/NTR Water Quality Criteria				
			Freshwater		Saltwater		Human Health for Consumption of:
			Acute	Chronic	Acute	Chronic	Organisms Only
			µg/L	µg/L	µg/L	µg/L	µg/L
2	Arsenic	36	340	150	69	36	--
3	Beryllium	No Criteria	--	--	--	--	--
5a	Chromium (III)	644	5405	644	--	--	--
6	Copper	3.73	51.68	30.50	5.78	3.73	--
7	Lead	8.52	476.82	18.58	220.82	8.52	--
9	Nickel	8.28	1,515.92	168.54	74.75	8.28	4,600
10	Selenium	5	--	5	290.58	71.14	--
12	Thallium	6.3	--	--	--	--	6.3
13	Zinc	85.62	387.83	387.83	95.14	85.62	--

3. Determining the Need for WQBELs

In accordance with section 1.3 of the SIP, the Regional Water Board conducted a RPA for each priority pollutant with an applicable criterion or objective to determine if a WQBEL is required in the Order. The Regional Water Board analyzed effluent data to determine if a pollutant in a discharge has the reasonable potential to cause or contribute to an excursion above a state water quality standard. For all parameters that have the reasonable potential to cause or contribute to an excursion above a water quality standard, numeric WQBELs are required. The RPA considers criteria from the CTR and NTR, and when applicable, water quality objectives specified in the Basin Plan. To conduct the RPA, the Regional Water Board identified the maximum observed effluent concentration (MEC) for each constituent, based on data provided by the Discharger.

Section 1.3 of the SIP provides the procedures for determining reasonable potential to exceed applicable water quality criteria and objectives. The SIP specifies three triggers to complete a RPA:

- 1) Trigger 1 – If the MEC is greater than or equal to the CTR water quality criteria or applicable objective (C), a limit is needed.
- 2) Trigger 2 – If background water quality (B) > C and the pollutant is detected in the effluent, a limit is needed.
- 3) Trigger 3 – If other related information, such as a 303(d) listing for a pollutant, discharge type, compliance history, etc., indicates that a WQBEL is required.

Sufficient effluent and ambient data are needed to conduct a complete RPA. If data are not sufficient, the Discharger will be required to gather the appropriate data for the Regional Water Board to conduct the RPA. In accordance with Section 1.2 of the SIP, the Regional Water Board shall have discretion to consider if any data are inappropriate for use in determining reasonable potential. To provide additional data for evaluating reasonable

potential, Special Provision VI.C.2.a of this Order requires the Discharger to conduct at least one round of effluent monitoring for priority pollutants and submit the laboratory results in accordance with the requirements contained in Section 2.4.2 of the SIP, within 90 days of the effective date of this Order. Upon review of the data, and if the Regional Water Board determines that WQBELs are needed to protect the beneficial uses, the permit will be reopened for appropriate modification.

The RPA was performed on available priority pollutant monitoring data collected by the Discharger on November 27, 2001. Based on the RPA, copper and selenium demonstrated reasonable potential to cause or contribute to an excursion above a water quality standard. Data used in the RPA are summarized in Table F-9.

Table F-9. Summary of Reasonable Potential Analysis

CTR No.	Parameter	Applicable Water Quality Criteria (C)	Max Effluent Concentration (MEC)	Maximum Detected Receiving Water Concentration (B)	RPA Result - Limit Required?	Reason
		µg/L	µg/L	µg/L		
2	Arsenic	36	3.5	5	No	MEC and B < C
3	Beryllium	No Criteria	< 0.4 (ND)	0.6	No	No Criteria
5a	Chromium (III)	644	< 1.1 (ND)	3.1	No	MEC and B < C
6	Copper	3.73	7.9	12	Yes	MEC >=C
7	Lead	8.52	0.9	3.6	No	MEC and B < C
9	Nickel	8.28	2.3	3.9	No	MEC and B < C
10	Selenium	5	3.2	7.7	Yes	B > C, and detected in effluent
12	Thallium	6.3	0.3 (DNQ)	1.4	No	MEC < C & B = ND
13	Zinc	85.62	8	9	No	MEC and B < C

ND = Not detected at or above detection limit for reporting

DNQ = Detected, but not quantified

4. WQBEL Calculations

a. Final WQBELs are based on monitoring results and following the calculation process outlined in section 1.4 of the SIP. A table providing the calculation for all applicable WQBELs for this Order is provided in Attachment I of this Order.

b. WQBELs Calculation Example

Using copper as an example, the following demonstrates how WQBELs based on aquatic life criterion were established for Order No. R7-2007-0034. The process for developing these limits is in accordance with section 1.4 of the SIP. Attachment I summarizes the development and calculation of all WQBELs for this Order using the process described below.

Step 1: For each constituent requiring an effluent limit, identify the applicable water quality criteria or objective. For each criterion determine the effluent concentration allowance (ECA) using the following steady state equation:

$$ECA = C + D(C-B) \quad \text{when } C > B, \text{ and}$$

$$ECA = C \quad \text{when } C \leq B,$$

Where C = The priority pollutant criterion/objective, adjusted if necessary for hardness, pH and translators. In this Order a hardness value of 400 mg/L (as CaCO₃) was used for development of hardness-dependant criteria, and a pH of 7.5 was used for pH-dependant criteria.

D = The dilution credit, and

B = The ambient background concentration

For this Order, dilution was not allowed due to the nature of the receiving water and quantity of the effluent; therefore:

$$ECA = C$$

For copper, the applicable water quality criteria are:

$$ECA_{acute} = 5.78 \mu\text{g/L}$$

$$ECA_{chronic} = 3.73 \mu\text{g/L}$$

$$ECA_{human\ health} = \text{Not Available}$$

Step 2: For each ECA based on aquatic life criterion/objective, determine the long-term average discharge condition (LTA) by multiplying the ECA by a factor (multiplier). The multiplier is a statistically based factor that adjusts the ECA to account for effluent variability. The value of the multiplier varies depending on the coefficient of variation (CV) of the data set and whether it is an acute or chronic criterion/objective. Table 1 of the SIP provides pre-calculated values for the multipliers based on the value of the CV. Equations to develop the multipliers in place of using values in the tables are provided in section 1.4, Step 3 of the SIP and will not be repeated here.

$$LTA_{acute} = ECA_{acute} \times \text{Multiplier}_{acute}$$

$$LTA_{chronic} = ECA_{chronic} \times \text{Multiplier}_{chronic}$$

The CV for the data set must be determined before the multipliers can be selected and will vary depending on the number of samples and the standard deviation of a data set. If the data set is less than 10 samples, or at least 80% of the samples in the data set are reported as non-detect, the CV shall be set equal to 0.6.

For copper, the following data was used to develop the acute and chronic LTA using Table 1 of the SIP:

<u>No. of Samples</u>	<u>CV</u>	<u>Multiplier_{acute}</u>	<u>Multiplier_{chronic}</u>
4	0.6	0.32	0.53

$$LTA_{acute} = 5.78 \mu\text{g/L} \times 0.32 = 1.86 \mu\text{g/L}$$

$$LTA_{chronic} = 3.73 \mu\text{g/L} \times 0.53 = 1.97 \mu\text{g/L}$$

Step 3: Select the most limiting (lowest) of the LTA.

$$LTA = \text{most limiting of } LTA_{\text{acute}} \text{ or } LTA_{\text{chronic}}$$

For copper, the most limiting LTA was the LTA_{acute}

$$LTA = 1.86 \mu\text{g/L}$$

Step 4: Calculate the WQBELs by multiplying the LTA by a factor (multiplier). WQBELs are expressed as Average Monthly Effluent Limitations (AMEL) and Maximum Daily Effluent Limitations (MDEL). The multiplier is a statistically based factor that adjusts the LTA for the averaging periods and exceedance frequencies of the criteria/objectives and the effluent limitations. The value of the multiplier varies depending on the probability basis, the coefficient of variation (CV) of the data set, the number of samples (for AMEL) and whether it is monthly or daily limit. Table 2 of the SIP provides pre-calculated values for the multipliers based on the value of the CV and the number of samples. Equations to develop the multipliers in place of using values in the tables are provided in section 1.4, Step 5 of the SIP and will not be repeated here.

$$AMEL_{\text{aquatic life}} = LTA \times AMEL_{\text{multiplier}}$$

$$MDEL_{\text{aquatic life}} = LTA \times MDEL_{\text{multiplier}}$$

AMEL multipliers are based on a 95th percentile occurrence probability, and the MDEL multipliers are based on the 99th percentile occurrence probability. If the number of samples is less than four (4), the default number of samples to be used is four (4).

For copper, the following data was used to develop the AMEL and MDEL for aquatic life using Table 2 of the SIP:

<u>No. of Samples</u>	<u>CV</u>	<u>Multiplier_{MDEL}</u>	<u>Multiplier_{AMEL}</u>
4	0.6	3.11	1.55

$$AMEL_{\text{aquatic life}} = 1.85 \times 1.55 = 2.9 \mu\text{g/L}$$

$$MDEL_{\text{aquatic life}} = 1.85 \times 3.11 = 5.8 \mu\text{g/L}$$

Step 5: For the ECA based on human health, set the AMEL equal to the $ECA_{\text{human health}}$

$$AMEL_{\text{human health}} = ECA_{\text{human health}}$$

However, for copper, there $ECA_{\text{human health}} = \text{Not Available}$. The CTR does not contain a numeric copper criterion protective of human health; therefore, it was not possible to develop a copper AMEL based on human health criteria.

Step 6: Calculate the MDEL for human health by multiplying the AMEL by the ratio of the $Multiplier_{\text{MDEL}}$ to the $Multiplier_{\text{AMEL}}$. Table 2 of the SIP provides pre-calculated ratios to be used in this calculation based on the CV and the number of samples.

A copper MDEL_{human health} could not be calculated because a copper AMEL_{human health} was not available. There are no criteria protective of human health for copper; therefore, none of the limitations for copper are based on human health criteria.

Step 7: Select the lower of the AMEL and MDEL based on aquatic life and human health as the water-quality based effluent limit for the Order.

AMEL _{aquatic life}	MDEL _{aquatic life}	AMEL _{human health}	MDEL _{human health}
2.9 µg/L	5.8 µg/L	Not Applicable	Not Applicable

For copper, there are no human health criteria; therefore, the AMEL and MDEL based on aquatic life criteria are considered for WQBELs. The lowest (most restrictive) effluent limits, those based on aquatic life criteria, were incorporated into this Order.

c. WQBELs Based on Basin Plan Objectives

- 1) Previous Order No. R7-2002-0004 established WQBELs for TDS. These WQBELs were based on receiving water quality objectives established in the Basin Plan that state any discharge to Trifolium Drain No. 6 shall not cause the concentration of TDS in the surface water to exceed a 30-Day Average of 4,000 mg/L and a 7-Day Average of 4,500 mg/L. Due to the misapplication of the Basin Plan receiving water quality objectives for TDS as numeric effluent limitations, this Order replaces the numeric effluent limitations for TDS of the previous permit with a narrative effluent limitation and establishes a receiving water limitation for TDS to accurately apply the WQO of the Basin Plan. The replacement of those numeric effluent limitations with a narrative effluent limitation and receiving water limitation for TDS does not constitute backsliding due to the exception contained in Section 402(o)(2)(B)(ii) of the CWA which states that if the Administrator determines that a technical mistake or mistake in interpretation of the law were made when establishing the limits, the appropriate application of those laws is justified. Further, the effluent data were compared to the Basin Plan receiving water quality objectives; the reported concentrations in the discharge are all less than the water quality objectives.
- 2) The Basin Plan states that any discharge to a water body with a REC1 designated use shall not have bacterial densities in excess of the following:
 - i. ***E. Coli***. The geometric mean bacterial density (based on a minimum of not less than five samples equally spaced over a 30-day period) shall not exceed a Most Probable Number (MPN) of 126 MPN per 100 milliliters, nor shall any sample exceed the maximum allowable bacterial density of 400 MPN per 100 milliliters.
 - ii. **Enterococci**. The geometric mean bacterial density (based on a minimum of not less than five samples equally spaced over a 30-day period) shall not exceed a Most Probable Number (MPN) of 33 MPN per 100 milliliters, nor shall any sample exceed the maximum allowable bacterial density of 100 MPN per 100 milliliters.
 - iii. **Fecal Coliform**. The geometric mean bacterial density (based on a minimum of not less than five samples equally spaced over a 30-day period) shall not exceed a Most Probable Number (MPN) of 200 MPN per 100 milliliters, nor shall more than ten percent of the total samples during any 30-day period exceed 400 MPN per 100 milliliters.

Effluent limitations for *E.coli*, enterococci and fecal coliform are incorporated in this Order. The bacterial indicators of *E. coli*, enterococci and fecal coliform are used to estimate the presence of pathogens in the wastewater effluent discharged to outfall 001. Effluent limitations for *E. coli*, enterococci and fecal coliform shall be used as indicators to determine the effectiveness of the municipal wastewater treatment facilities disinfection system.

- 3) The Basin Plans general surface water objectives state that all waters shall be maintained free of toxic substances in concentrations which are toxic to, or which produce detrimental physiological responses in human, plant, animal, or indigenous aquatic life. Chlorine is known to be toxic to aquatic life. The previous Order establishes numeric effluent limitations for total chlorine residual. These effluent limitations are carried over to the proposed Order. Wastewater discharged to Trifolium Drain No. 6 shall not contain a total chlorine residual greater than 0.2 mg/L as an instantaneous maximum and 0.01 mg/L as a monthly average.
- 4) The Water Quality-based Effluent Limitations for Discharge Point 001 are as follows:

**Summary of Water Quality-based Effluent Limitations
 Discharge Point 001**

Table F-10. Summary of Water Quality-based Effluent Limitations

Parameter	Units	Effluent Limitations				
		Average Monthly	Average Weekly	Maximum Daily	Instantaneous Minimum	Instantaneous Maximum
Copper, Total Recoverable	µg/L	2.9	---	5.8	---	---
	lbs/day ¹	0.012	---	0.024	---	---
Selenium, Total Recoverable	µg/L	4.1	---	8.2	---	---
	lbs/day ¹	0.017	---	0.034	---	---
Chlorine, Total Residual	mg/L	0.01	---	---	---	0.02
	lbs/day ¹	0.04	---	---	---	0.08
Enterococci	MPN/100mls	33 ³	--	100	--	--
Escherichia Coli (E. Coli)	MPN/100mls	126 ²	---	400	---	---
Fecal Coliform	MPN/100mls	200 ²	---	400 ³	---	---

¹ The mass-based effluent limitations are based on a design capacity of 0.5 MGD.

² Based on a minimum of not less than five samples for any 30-day period.

³ No more than ten percent of the total fecal coliform samples collected during any 30-day period shall exceed 400 MPN per 100 milliliters.

5. Whole Effluent Toxicity (WET)

Whole effluent toxicity (WET) protects the receiving water quality from the aggregate toxic effect of a mixture of pollutants in the effluent. WET tests measure the degree of response of exposed aquatic test organisms to an effluent. The WET approach allows for protection of the narrative “no toxics in toxic amounts” criterion while implementing numeric criteria for toxicity. There are two types of WET tests: acute and chronic. An acute toxicity test is conducted over a shorter time period and measures mortality. A chronic toxicity test is

conducted over a longer period of time and may measure mortality, reproduction, and growth.

The Basin Plan specifies a narrative objective for toxicity, requiring that all waters be maintained free of toxic substances in concentrations that are lethal to or produce other detrimental response on aquatic organisms. Detrimental response includes but is not limited to decreased growth rate, decreased reproductive success of resident or indicator species, and/or significant alterations in population, community ecology, or receiving water biota.

This Order implements the narrative objective for toxicity, requiring there shall be no acute or chronic toxicity in the treatment plant effluent. In addition, the Order establishes thresholds that when exceeded requires the Discharger to conduct accelerated toxicity testing and/or conduct toxicity identification evaluation (TIE) and toxicity reduction evaluation (TRE) studies.

On November 17, 2002, the Discharger initiated 4th Quarter bioassay/accelerated monitoring and TIE testing. According to the Discharger, there were difficulties in taking these tests to completion (letter dated, December 4, 2002). Based on correspondence between the Discharger and the laboratory, several problems prevented the Discharger from obtaining results, including the use of unhealthy fathead minnows for the test. All other test results are discussed in Section II.D. of the Fact Sheet.

In addition to the Basin Plan requirements, section 4 of the SIP states that a chronic toxicity effluent limitation is required in permits for all discharges that will cause, have the reasonable potential to cause, or contribute to chronic toxicity in receiving waters. Therefore, in accordance with the SIP, this Order requires the Discharger to conduct chronic toxicity testing for discharges to the Trifolium Drain No. 6 (one of the Imperial Valley Drains).

D. FINAL EFFLUENT LIMITATIONS

Table F-11, below, summarizes the proposed effluent limitations for the discharge through Discharge Point 001. Proposed effluent limitations are based on secondary treatment standards, California Toxics Rule, and Colorado River Basin Plan Water Quality Standards.

1. Mass-based Effluent Limitations

Title 40 CFR Section 122.45(f)(1) requires effluent limitations be expressed in terms of mass, with some exceptions, and 40 CFR 122.45(f)(2) allows pollutants that are limited in terms of mass to additionally be limited in terms of other units of measurement. This Order includes effluent limitations expressed in terms of mass and concentration. In addition, pursuant to the exceptions to mass limitations provided in 40 CFR 122.45(f)(1), some effluent limitations are not expressed in terms of mass, such as pH and temperature, and when the applicable standards are expressed in terms of concentration (e.g. CTR criteria and MCLs) and mass limitations are not necessary to protect the beneficial uses of the receiving water.

Mass-based effluent limitations are established using the following formula:

$$\text{Mass (lbs/day)} = \text{flow rate (MGD)} \times 8.34 \times \text{effluent limitation (mg/L)}$$

where: Mass = mass limitation for a pollutant (lbs/day)

Effluent limitation = concentration limit for a pollutant (mg/L)

Flow rate = discharge flow rate (MGD)

2. Final Effluent Limitations

- a. The Discharger shall maintain compliance with the following effluent limitations at Discharge Point 001, with compliance measured at Monitoring Location EFF-001 as described in the MRP.

Summary of Final Effluent Limitations Discharge Point 001 at Monitoring Location EFF-001

Table F-11. Summary of Final Effluent Limitations

Parameter	Units	Effluent Limitations					Basis
		Average Monthly	Average Weekly	Maximum Daily	Instantaneous Minimum	Instantaneous Maximum	
Daily Effluent Flow	MGD	0.5	---	---	---	---	
Biochemical Oxygen Demand (BOD) (5-day @ 20 Deg. C)	mg/L	30	45	---	---	---	40 CFR 133
	lbs/day	130	190	---	---	---	
Total Suspended Solids (TSS)	mg/L	30	45	---	---	---	40 CFR 133
	lbs/day	130	190	---	---	---	
pH	s.u.	---	---	---	6.0	9.0	40 CFR 133
Copper, Total Recoverable ¹	µg/L	2.9	---	5.8	---	---	CTR, SIP
	lbs/day	0.012	---	0.024	---	---	
Selenium, Total Recoverable	µg/L	4.1	---	8.2	---	---	CTR, SIP
	lbs/day	0.017	---	0.034	---	---	
Chlorine, Total Residual	mg/L	0.01	---	---	---	0.02	Basin Plan
	lbs/day	0.04	---	---	---	0.08	

¹ The effluent limitations for Copper are applicable on May 18, 2010 provided the Discharger submits an Infeasibility Report for copper to the Regional Water Board by October 19, 2007.

- b. **Percent Removal:** The average monthly percent removal of BOD 5-day 20°C and total suspended solids shall not be less than 85 percent.
- c. **Toxicity:** There shall be no acute or chronic toxicity in the treatment plant effluent nor shall the treatment plant effluent cause any acute or chronic toxicity in the receiving water. All waters shall be maintained free of toxic substances in concentrations which are toxic to, or which produce detrimental physiological responses in human, plant, animal, or indigenous aquatic life. Compliance with this objective will be determined by use of indicator organisms, analyses of species diversity, population density, growth anomalies, or bioassays of appropriate duration or other appropriate methods specified by the Regional Water Board.
- d. **Bacteria:** The bacterial concentrations in the wastewater effluent discharged to the New River shall not exceed the following concentrations, as measured by the following bacterial indicators:

- i. ***E. Coli***. The geometric mean bacterial density (based on a minimum of not less than five samples equally spaced over a 30-day period) shall not exceed a Most Probable Number (MPN) of 126 MPN per 100 milliliters, nor shall any sample exceed the maximum allowable bacterial density of 400 MPN per 100 milliliters.
 - ii. **Enterococci**. The geometric mean bacterial density (based on a minimum of not less than five samples equally spaced over a 30-day period) shall not exceed a Most Probable Number (MPN) of 33 MPN per 100 milliliters, nor shall any sample exceed the maximum allowable bacterial density of 100 MPN per 100 milliliters.
 - iii. **Fecal Coliform**. The geometric mean bacterial density (based on a minimum of not less than five samples equally spaced over a 30-day period) shall not exceed a Most Probable Number (MPN) of 200 MPN per 100 milliliters, nor shall more than ten percent of the total samples during any 30-day period exceed 400 MPN per 100 milliliters.
- e. **Total Dissolved Solids:** Discharges of wastes or wastewater shall not increase the total dissolved solids content of receiving waters, unless it can be demonstrated to the satisfaction of the Regional Water Board that such an increase in total dissolved solids does not adversely affect beneficial uses of receiving waters.

3. Satisfaction of Anti-Backsliding Requirements

Title 40 CFR Sections 402(o)(2) and 303(d)(4) of the CWA and federal regulations at Title 40, CFR Section 122.44(l) prohibit backsliding in NPDES permits. These anti-backsliding provisions require that effluent limitations in a reissued permit must be as stringent as those in the previous permit, with some exceptions in which limitations may be relaxed. Some effluent limitations in this Order are less stringent than those in the previous Order. The numeric effluent limitations for total dissolved solids has been replaced by a narrative limitation. As discussed in detail in section IV.C.4 of this Fact Sheet, this relaxation of effluent limitations is consistent with the anti-backsliding requirements of the CWA and federal regulations.

4. Satisfaction of Anti-degradation Policy

Section 131.12 requires that the state water quality standards include an anti-degradation policy consistent with the federal policy. The State Water Board established California's anti-degradation policy in State Water Board Resolution No. 68-16. Resolution No. 68-16 incorporates the federal anti-degradation policy where the federal policy applies under federal law. Resolution No. 68-16 requires that existing water quality be maintained unless degradation is justified based on specific findings. The Regional Water Board's Basin Plan implements, and incorporates by reference, both the State and federal anti-degradation policies. As discussed in detail in Fact Sheet section III.C.10, the permitted discharge is consistent with the anti-degradation provision of Section 131.12 and State Water Board Resolution No. 68-16.

5. Stringency of Requirements for Individual Pollutants

This Order contains both technology-based and water quality-based effluent limitations for individual pollutants. The technology-based effluent limitations consist of restrictions on BOD₅, TSS, pH, and percent removal for BOD and TSS. Restrictions on BOD₅, TSS, pH, and percent removal for BOD and TSS are discussed in Section IV.B.2.a of the Fact Sheet. This Order's technology-based pollutant restrictions implement the minimum, applicable federal technology-based requirements. The water quality-based effluent limitations consist of restrictions on copper, selenium, total chlorine residual, enterococci, *E. Coli* and fecal coliform. Restrictions on copper, selenium, total chlorine residual, enterococci, *E. Coli* and fecal coliform are discussed in Section IV.C of the Fact Sheet.

Water quality-based effluent limitations have been scientifically derived to implement water quality objectives that protect beneficial uses. Both the beneficial uses and the water quality objectives have been approved pursuant to federal law and are the applicable federal water quality standards. To the extent that toxic pollutant WQBELs were derived from the CTR, the CTR is the applicable standard pursuant to Section 131.38. The scientific procedures for calculating the individual WQBELs for priority pollutants are based on the CTR-SIP, which was approved by USEPA on May 18, 2000. All beneficial uses and water quality objectives contained in the Basin Plan were approved under state law and submitted to and approved by USEPA prior to May 30, 2000. Any water quality objectives and beneficial uses submitted to USEPA prior to May 30, 2000, but not approved by USEPA before that date, are nonetheless "applicable water quality standards for purposes of the CWA" pursuant to Section 131.21(c)(1). Collectively, this Order's restrictions on individual pollutants are no more stringent than required to implement the requirements of the CWA.

E. INTERIM EFFLUENT LIMITATIONS

The Discharger may not be able to consistently comply with the new effluent limitations for copper. Therefore, interim limits have been set as follows:

1. The governing WQC for copper is 3.73 µg/L, the saltwater aquatic life criteria contained in the CTR. Copper demonstrated reasonable potential to exceed water quality criteria, and final WQBELs are required. The WQBELs calculated pursuant to SIP procedures are 2.9 µg/L AMEL and 5.8 µg/L MDEL.

The Discharger is required to submit a Copper Feasibility Study by October 19, 2007 to demonstrate that it is infeasible to comply immediately with the WQBELs. Therefore, based on a review of self-monitoring data, an interim effluent limit for copper is required. Section 2.2 of the SIP states numeric interim limitations must be based on current treatment Facility performance or on existing permit limitations, whichever is more stringent. The previous permit did not contain an effluent limitation for copper. The Regional Water Board evaluated effluent monitoring data submitted for copper for the period from November 2001 through July 2006; to date, the Discharger has provided only one data point for copper. There are insufficient data to statistically evaluate performance. The Regional Water Board set the interim limitation equal to the MEC value for copper, 7.9 µg/L, for both the average monthly and maximum daily interim limit. These interim limitations are based on the best professional judgment of Regional Water Board staff.

Table F-12. Interim Effluent Limitations

Parameter	Units	Date Effluent Limit Becomes Effective	Maximum Daily Effluent Limit (MDEL)	Average Monthly Effluent Limit (AMEL)
Copper (interim)	µg/L	September 19, 2007 ¹	7.9	7.9
	lbs/day ²		0.033	0.033
Copper (final)	µg/L	May 18, 2010	5.8	2.9
	lbs/day ²		0.024	0.012

¹ In accordance with Special Provision VI.C.2.b of this Order, the Discharger shall submit a Copper Infeasibility Report by October 19, 2007 for the Interim Effluent Limitations described in Section IV.A.2 for copper to remain effective. If the Regional Water Board has not received the Copper Infeasibility Report by October 19, 2007, the final effluent limitations for copper specified in Section IV.A.1.a become effective on October 19, 2007.

² Based on a design treatment capacity of 0.50 MGD.

F. LAND DISCHARGE SPECIFICATIONS – NOT APPLICABLE

G. RECLAMATION SPECIFICATIONS – NOT APPLICABLE

V. RATIONALE FOR RECEIVING WATER LIMITATIONS

The receiving water limitations in the proposed Order are based upon the water quality objectives contained in the Basin Plan. As such, they are a required part of the proposed Order.

A. SURFACE WATER

The surface water receiving water limitations in the proposed Order are based upon the water quality objectives contained in the Basin Plan and are carried forward from the previous Order. As such, they are a required part of the proposed Order. The receiving water limitations for dissolved oxygen, pH and temperature are as follows:

The discharge shall not cause the concentration of dissolved oxygen in the receiving water to fall below 5.0 mg/L. When the dissolved oxygen in the receiving water is already below 5.0 mg/L, the discharge shall not cause any further depression.

The discharge shall not result in the normal ambient pH of the receiving water to fall below 6.0 or exceed 9.0 units.

The discharge shall not result in the natural receiving water temperature to be altered, unless it can be demonstrated to the satisfaction of the Regional Water Board that such alteration in temperature does not adversely affect beneficial uses.

Also, a new receiving water limitation was added for TDS based on the Regional Water Board’s Basin Plan as follows:

The discharge shall not cause the concentration of total dissolved solids in the Trifolium Drain No. 6 to exceed an annual average concentration of 4,000 mg/L or an instantaneous maximum concentration of 4,500 mg/L.

B. GROUNDWATER – NOT APPLICABLE

VI. RATIONALE FOR MONITORING AND REPORTING REQUIREMENTS

Section 122.48 requires that all NPDES permits specify requirements for recording and reporting monitoring results. Water Code Sections 13267 and 13383 authorizes the Regional Water Board to require technical and monitoring reports. The MRP, Attachment E of this Order, establishes monitoring and reporting requirements to implement federal and state requirements. The following provides the rationale for the monitoring and reporting requirements contained in the MRP for this facility.

A. INFLUENT MONITORING

This Order carries forward the treatment plant influent monitoring requirements. In addition, influent flow monitoring has been established to determine if adequate treatment capacity is available at the facility and determine compliance with Provision VI.A.2.f of the Order.

B. EFFLUENT MONITORING

The Discharger is required to conduct monitoring of the permitted discharges in order to evaluate compliance with permit conditions. Monitoring requirements are given in the proposed MRP. This provision requires compliance with the MRP, and is based on Sections 122.44(i), 122.62, 122.63 and 124.5. The MRP is a standard requirement in almost all NPDES permits (including the proposed Order) issued by the Regional Water Board. In addition to containing definitions of terms, it specifies general sampling/analytical protocols and the requirements of reporting of spills, violations, and routine monitoring data in accordance with NPDES regulations, the CWC, and Regional Water Board's policies. The MRP also contains sampling program specific for the Discharger's wastewater treatment plant. It defines the sampling stations and frequency, pollutants to be monitored, and additional reporting requirements. Pollutants to be monitored include all pollutants for which effluent limitations are specified. Further, in accordance with section 1.3 of the SIP, periodic monitoring is required for all priority pollutants defined by the CTR, for which criteria apply and for which no effluent limitations have been established, to evaluate reasonable potential to cause or contribute to an excursion above a water quality standard.

Monitoring for those pollutants expected to be present in the discharge from the Facility, EFF-001, will be required as shown in the proposed MRP and as required by the SIP.

Monitoring requirements are largely unchanged from the previous Order. Monitoring once per month for copper and selenium have been established because copper was detected in the effluent at levels above final WQBELs and selenium was detected in the effluent and was also detected in the receiving water at levels above final WQBELs. In addition, monitoring for enterococci and fecal coliform have been added to be consistent with the requirements of the Basin Plan. Further, the previous Order included a specific effluent monitoring requirement for dioxin. Due to the inclusion of dioxin monitoring in the priority pollutant monitoring required by this Order, the dioxin-specific monitoring requirement has been removed. Finally, annual monitoring for priority pollutants in the effluent is required in accordance with the SIP.

C. WHOLE EFFLUENT TOXICITY TESTING REQUIREMENTS

Whole effluent toxicity (WET) testing requirements establish monitoring of the effluent to ensure that the receiving water quality is protected from the aggregate toxic effect of a mixture of pollutants in the effluent. An acute toxicity test is conducted over a short time period and measures mortality. A chronic toxicity test is conducted over a longer period of time and may measure mortality, reproduction, and growth.

This requirement establishes conditions and protocol by which compliance with the Basin Plan narrative water quality objective for toxicity will be demonstrated and in accordance with section 4.0 of the SIP. Conditions include required monitoring and evaluation of the effluent for acute and chronic toxicity and numerical values for chronic toxicity evaluation to be used as 'triggers' for initiating accelerated monitoring and toxicity reduction evaluation(s).

The WET testing requirements contained in the MRP, Section V were developed based on the Draft National Whole Effluent Toxicity Implementation Guidance Under the NPDES Program developed by USEPA (Docket ID. No. OW-2004-0037). This is the most current guidance available to the Regional Water Board. This Order includes a reopener to allow the requirements of this section to be revised pending the issuance of final guidance or policies developed by either the USEPA or State Water Board.

D. RECEIVING WATER MONITORING

1. Surface Water

Surface water monitoring is required to determine compliance with receiving water limitations and to characterize the water quality of the receiving water pursuant to the SIP and Basin Plan. To provide ambient background receiving water quality data, monitoring requirements for monitoring location RSW-001 have been carried over from those established for RSW-001 in the previous Order. Due to insufficient data for priority pollutants, annual monitoring for priority pollutants has been included in this Order. In the event that no receiving water is present at station RSW-001, receiving water monitoring may be suspended until receiving water flow is present at station RSW-001.

2. Groundwater – Not Applicable

E. OTHER MONITORING REQUIREMENTS

1. Water Supply Monitoring

The Discharger is required to obtain or acquire quarterly total dissolved solids concentrations of the source water, either through monitoring or obtaining the data from the drinking water purveyor. This information will be compiled and summarized in a quarterly report, in accordance with Provision VI.C.2.e of the proposed Order.

2. Biosolids/Sludge Monitoring

This section establishes monitoring and reporting requirements for the storage, handling and disposal practices of sludge generated from the operation of this Facility. All sludge and or solids generated at the treatment plant will be disposed, treated, or applied to land in accordance with Federal Regulations 40 CFR 503. The previous Order required sludge monitoring on an annual basis. This monitoring will be carried over from the previous permit.

VII. RATIONALE FOR PROVISIONS

A. STANDARD PROVISIONS

Standard Provisions, which apply to all NPDES permits in accordance with 40 CFR Section 122.41, and additional conditions applicable to specified categories of permits in accordance with Section 122.42, are provided in Attachment D. The Discharger must comply with all standard provisions and with those additional conditions that are applicable under Section 122.42.

Section 122.41(a)(1) and (b) through (n) establish conditions that apply to all State-issued NPDES permits. These conditions must be incorporated into the permits either expressly or by reference. If incorporated by reference, a specific citation to the regulations must be included in the Order. Section 123.25(a)(12) allows the state to omit or modify conditions to impose more stringent requirements. In accordance with Section 123.25, this Order omits federal conditions that address enforcement authority specified in Sections 122.41(j)(5) and (k)(2) because the enforcement authority under the Water Code is more stringent. In lieu of these conditions, this Order incorporates by reference Water Code Section 13387(e).

B. SPECIAL PROVISIONS

1. Reopener Provisions

This provision is based on Part 123. The Regional Water Board may reopen the permit to modify permit conditions and requirements. Causes for modifications include the promulgation of new regulations, modification in sludge use or disposal practices, or adoption of new regulations by the State Water Board or Regional Water Board, including revisions to the Basin Plan.

2. Special Studies and Additional Monitoring Requirements

- a. **Monitoring for Priority Pollutants.** This provision is based on the SIP. This provision requires the Discharger to implement monitoring and reporting methods established in the SIP, Sections 2.3 and 2.4.
- b. **Copper Infeasibility Report.** This provision is based on the SIP, Section 2.1 of the SIP, Compliance Schedules.
- c. **Toxicity Identification Evaluations or Toxicity Reduction Evaluations.** This provision is based on the SIP, Section 4, Toxicity Control Provisions.
- d. **Translator Study.** This provision is based on the SIP. This provision allows the Discharger to conduct an optional translator study, based on the SIP at the Discharger's discretion. This provision is based on the need to gather site-specific information in order to apply a different translator from the default translator specified in the CTR and SIP. Without site-specific data, the default translators are used with the CTR criteria.
- e. **Total Dissolved Solids (TDS) Study.** The purpose of this study is to provide more detailed information on the Regional Board's development of salinity standards pursuant to Section 303 of the CWA and through the NPDES permitting authority in the regulation of municipal and industrial sources (see section 402 of the Federal Water Pollution Control Act). As part of the Regional Board's development of salinity standards, the Regional Board is requiring a study to determine what is a reasonable increase in salinity for municipal discharges to surface waters and its impact on the beneficial uses of waters of the United States. As part of the 1996 Review of the Water Quality Standards for Salinity of the Colorado River System dated June 1996, the study proposed that an incremental increase in salinity shall be 400 mg/L or less, which is considered to be a reasonable incremental increase above the flow weighted average salinity of the source water supply. As part of this permit, the Discharger is required to perform a study to evaluate whether a 400 mg/L incremental increase in salinity above the source water is practical and if not, what incremental increase is practical for their discharge. This report shall be submitted to the Regional Board's Executive Officer prior to the filing date for re-application.

3. Best Management Practices and Pollution Prevention

- a. **Pollutant Minimization Program.** This provision is based on the requirements of Section 2.4.5 of the SIP.

- b. **Storm Water.** This provision is based on Water Quality Order No. 97-03-DWQ, NPDES General Permit No. CAS000001 for Discharges of Storm Water Associated with Industrial Activities.

4. Construction, Operation, and Maintenance Specifications

- a. **Facility and Treatment Operation.** This provision is based on the requirements of 40 CFR §122.41(e) and the previous Order.
- b. **Spill Response Plan.** This provision is based on the requirements of 40 CFR §122.41(e) and the previous Order.
- c. **Operations Plan for Constructed Wetlands.** This requirement is based on the Discharger's proposal to include an adjacent facultative wetlands as additional treatment on the effluent discharged through Discharge Point 001. The Discharger is required develop an Operations Plan which evaluates treatment purposes, maintenance and upkeep schedules and any additional operational issues that may affect the plant's ability to comply with effluent limitations.

5. Special Provisions for Municipal Facilities (POTWs Only)

- a. **Sludge Disposal Requirements.** Requirements are based on the previous Order and 40 CFR Part 503.
- b. **Pretreatment Program Requirements.** Requirements are based on the previous Order and 40 CFR Part 403.

6. Other Special Provisions

Special Provisions VI.C.6.a, VI.C.6.b, and VI.C.6.c are included to ensure the compliance with requirements established in Order No. R7-2007-0034, and are based on the previous Order, the CWA, USEPA regulations, CWC, and Regional Water Board plans and policies.

7. Compliance Schedules

- a. This Order establishes final effluent limitations for copper that are new limitations for the facility. This Order also contains interim effluent limitations and a compliance schedule that provides the Discharger time to bring their facility into compliance with the newly established final limitations for copper. In accordance with section 2.1 of the SIP, interim limitations and compliance schedules can only be provided by the Regional Water Board after the Discharger has submitted a report that demonstrates and justifies that it is infeasible for the Discharger to achieve immediate compliance with newly established final effluent limitations. Infeasible means not capable of being accomplished in a successful manner within a reasonable period of time, taking into account economic, environmental, legal, social and technological factors. As required by Special Provision VI.C.7.a in the proposed Order, the Discharger shall implement the Copper Compliance Plan that identifies the measures that will be taken to achieve compliance with the permit limitations specified in Effluent Limitations, section IV.A.1.a of this Order.

The provision for compliance schedule is based on Section 2.1 (Compliance Schedules) of the SIP. The proposed permit allows the Discharger until May 18, 2010 to be in compliance with the final effluent limitations for copper. Annual reporting is required to inform the Regional Water Board about the progress made by the Discharger to achieve compliance with the final limitations within the specified time. During the interim period, the Discharger is required to meet the interim limitations.

VIII. PUBLIC PARTICIPATION

The Regional Water Board is considering the issuance of WDRs that will serve as an NPDES permit for the City of Westmorland Wastewater Treatment Plant. As a step in the WDRs adoption process, the Regional Water Board staff has developed tentative WDRs. The Regional Water Board encourages public participation in the WDRs adoption process.

A. NOTIFICATION OF INTERESTED PARTIES

The Regional Water Board has notified the Discharger and interested agencies and persons of its intent to prescribe WDRs for the discharge and has provided them with an opportunity to submit their written comments and recommendations. Notification was provided through the following newspapers: Desert Sun and Imperial Valley Press.

B. WRITTEN COMMENTS

The staff determinations are tentative. Interested persons are invited to submit written comments concerning these tentative WDRs. Comments must be submitted either in person or by mail to the Executive Office at the Regional Water Board at the address above on the cover page of this Order.

To be fully responded to by staff and considered by the Regional Water Board, written comments should be received at the Regional Water Board offices by 5:00 p.m. on August 31, 2007.

C. PUBLIC HEARING

The Regional Water Board will hold a public hearing on the tentative WDRs during its regular Board meeting on the following date and time and at the following location:

Date: September 19, 2007
Time: 10:00 a.m.
Location: City of Council Chambers
City of La Quinta
78-495 Calle Tampico
La Quinta, CA 92253

Interested persons are invited to attend. At the public hearing, the Regional Water Board will hear testimony, if any, pertinent to the discharge, WDRs, and permit. Oral testimony will be heard; however, for accuracy of the record, important testimony should be in writing.

Please be aware that dates and venues may change. Our Web address is www.waterboards.ca/gov/coloradoriver where you can access the current agenda for changes in dates and locations.

D. WASTE DISCHARGE REQUIREMENTS PETITIONS

Any aggrieved person may petition the State Water Resources Control Board to review the decision of the Regional Water Board regarding the final WDRs. The petition must be submitted within 30 days of the Regional Water Board's decision to the following address:

State Water Resources Control Board
Office of Chief Counsel
P.O. Box 100
Sacramento, CA 95812-0100

E. INFORMATION AND COPYING

The ROWD (ROWD), related documents, tentative effluent limitations and special provisions, comments received, and other information are on file and may be inspected at the address above at any time between 8:30 a.m. and 4:45 p.m., Monday through Friday. Copying of documents may be arranged through the Regional Water Board by calling Colorado River Basin Regional Water Board at (760) 346-7491.

F. REGISTER OF INTERESTED PERSONS

Any person interested in being placed on the mailing list for information regarding the WDRs and NPDES permit should contact the Regional Water Board, reference this facility, and provide a name, address, and phone number.

G. ADDITIONAL INFORMATION

Requests for additional information or questions regarding this order should be directed to Kirk Larkin at (760) 776-8964.

ATTACHMENT G – LIST OF PRIORITY POLLUTANTS

Table G-1 List of Priority Pollutants

CTR Number	Parameter	CAS Number	Suggested Analytical Methods
1	Antimony	7440360	EPA 6020/200.8
2	Arsenic	7440382	EPA 1632
3	Beryllium	7440417	EPA 6020/200.8
4	Cadmium	7440439	EPA 1638/200.8
5a	Chromium (III)	16065831	EPA 6020/200.8
5a	Chromium (VI)	18540299	EPA 7199/1636
6	Copper	7440508	EPA 6020/200.8
7	Lead	7439921	EPA 1638
8	Mercury	7439976	EPA 1669/1631
9	Nickel	7440020	EPA 6020/200.8
10	Selenium	7782492	EPA 6020/200.8
11	Silver	7440224	EPA 6020/200.8
12	Thallium	7440280	EPA 6020/200.8
13	Zinc	7440666	EPA 6020/200.8
14	Cyanide	57125	EPA 9012A
15	Asbestos	1332214	EPA/600/R-93/116(PCM)
16	2,3,7,8-TCDD	1746016	EPA 8290 (HRGC) MS
17	Acrolein	107028	EPA 8260B
18	Acrylonitrile	107131	EPA 8260B
19	Benzene	71432	EPA 8260B
20	Bromoform	75252	EPA 8260B
21	Carbon Tetrachloride	56235	EPA 8260B
22	Chlorobenzene	108907	EPA 8260B
23	Chlorodibromomethane	124481	EPA 8260B
24	Chloroethane	75003	EPA 8260B
25	2-Chloroethylvinyl Ether	110758	EPA 8260B
26	Chloroform	67663	EPA 8260B
27	Dichlorobromomethane	75274	EPA 8260B
28	1,1-Dichloroethane	75343	EPA 8260B
29	1,2-Dichloroethane	107062	EPA 8260B
30	1,1-Dichloroethylene	75354	EPA 8260B
31	1,2-Dichloropropane	78875	EPA 8260B
32	1,3-Dichloropropylene	542756	EPA 8260B

CTR Number	Parameter	CAS Number	Suggested Analytical Methods
33	Ethylbenzene	100414	EPA 8260B
34	Methyl Bromide	74839	EPA 8260B
35	Methyl Chloride	74873	EPA 8260B
36	Methylene Chloride	75092	EPA 8260B
37	1,1,2,2-Tetrachloroethane	79345	EPA 8260B
38	Tetrachloroethylene	127184	EPA 8260B
39	Toluene	108883	EPA 8260B
40	1,2-Trans-Dichloroethylene	156605	EPA 8260B
41	1,1,1-Trichloroethane	71556	EPA 8260B
42	1,1,2-Trichloroethane	79005	EPA 8260B
43	Trichloroethylene	79016	EPA 8260B
44	Vinyl Chloride	75014	EPA 8260B
45	2-Chlorophenol	95578	EPA 8270C
46	2,4-Dichlorophenol	120832	EPA 8270C
47	2,4-Dimethylphenol	105679	EPA 8270C
48	2-Methyl-4,6-Dinitrophenol	534521	EPA 8270C
49	2,4-Dinitrophenol	51285	EPA 8270C
50	2-Nitrophenol	88755	EPA 8270C
51	4-Nitrophenol	100027	EPA 8270C
52	3-Methyl-4-Chlorophenol	59507	EPA 8270C
53	Pentachlorophenol	87865	EPA 8270C
54	Phenol	108952	EPA 8270C
55	2,4,6-Trichlorophenol	88062	EPA 8270C
56	Acenaphthene	83329	EPA 8270C
57	Acenaphthylene	208968	EPA 8270C
58	Anthracene	120127	EPA 8270C
59	Benzidine	92875	EPA 8270C
60	Benzo(a)Anthracene	56553	EPA 8270C
61	Benzo(a)Pyrene	50328	EPA 8270C
62	Benzo(b)Fluoranthene	205992	EPA 8270C
63	Benzo(ghi)Perylene	191242	EPA 8270C
64	Benzo(k)Fluoranthene	207089	EPA 8270C
65	Bis(2-Chloroethoxy)Methane	111911	EPA 8270C
66	Bis(2-Chloroethyl)Ether	111444	EPA 8270C
67	Bis(2-Chloroisopropyl)Ether	108601	EPA 8270C
68	Bis(2-Ethylhexyl)Phthalate	117817	EPA 8270C
69	4-Bromophenyl Phenyl Ether	101553	EPA 8270C
70	Butylbenzyl Phthalate	85687	EPA 8270C
71	2-Chloronaphthalene	91587	EPA 8270C
72	4-Chlorophenyl Phenyl Ether	7005723	EPA 8270C

CTR Number	Parameter	CAS Number	Suggested Analytical Methods
73	Chrysene	218019	EPA 8270C
74	Dibenzo(a,h)Anthracene	53703	EPA 8270C
75	1,2-Dichlorobenzene	95501	EPA 8260B
76	1,3-Dichlorobenzene	541731	EPA 8260B
77	1,4-Dichlorobenzene	106467	EPA 8260B
78	3,3'-Dichlorobenzidine	91941	EPA 8270C
79	Diethyl Phthalate	84662	EPA 8270C
80	Dimethyl Phthalate	131113	EPA 8270C
81	Di-n-Butyl Phthalate	84742	EPA 8270C
82	2,4-Dinitrotoluene	121142	EPA 8270C
83	2,6-Dinitrotoluene	606202	EPA 8270C
84	Di-n-Octyl Phthalate	117840	EPA 8270C
85	1,2-Diphenylhydrazine	122667	EPA 8270C
86	Fluoranthene	206440	EPA 8270C
87	Fluorene	86737	EPA 8270C
88	Hexachlorobenzene	118741	EPA 8260B
89	Hexachlorobutadiene	87863	EPA 8260B
90	Hexachlorocyclopentadiene	77474	EPA 8270C
91	Hexachloroethane	67721	EPA 8260B
92	Indeno(1,2,3-cd)Pyrene	193395	EPA 8270C
93	Isophorone	78591	EPA 8270C
94	Naphthalene	91203	EPA 8260B
95	Nitrobenzene	98953	EPA 8270C
96	N-Nitrosodimethylamine	62759	EPA 8270C
97	N-Nitrosodi-n-Propylamine	621647	EPA 8270C
98	N-Nitrosodiphenylamine	86306	EPA 8270C
99	Phenanthrene	85018	EPA 8270C
100	Pyrene	129000	EPA 8270C
101	1,2,4-Trichlorobenzene	120821	EPA 8260B
102	Aldrin	309002	EPA 8081A
103	alpha-BHC	319846	EPA 8081A
104	beta-BHC	319857	EPA 8081A
105	gamma-BHC	58899	EPA 8081A
106	delta-BHC	319868	EPA 8081A
107	Chlordane	57749	EPA 8081A
108	4,4'-DDT	50293	EPA 8081A
109	4,4'-DDE	72559	EPA 8081A
110	4,4'-DDD	72548	EPA 8081A
111	Dieldrin	60571	EPA 8081A
112	alpha-Endosulfan	959988	EPA 8081A

CTR Number	Parameter	CAS Number	Suggested Analytical Methods
113	beta-Endosulfan	33213659	EPA 8081A
114	Endosulfan Sulfate	1031078	EPA 8081A
115	Endrin	72208	EPA 8081A
116	Endrin Aldehyde	7421934	EPA 8081A
117	Heptachlor	76448	EPA 8081A
118	Heptachlor Epoxide	1024573	EPA 8081A
119	PCB-1016	12674112	EPA 8082
120	PCB-1221	11104282	EPA 8082
121	PCB-1232	11141165	EPA 8082
122	PCB-1242	53469219	EPA 8082
123	PCB-1248	12672296	EPA 8082
124	PCB-1254	11097691	EPA 8082
125	PCB-1260	11096825	EPA 8082
126	Toxaphene	8001352	EPA 8081A

ATTACHMENT H – STATE WATER BOARD MINIMUM LEVELS

The State Water Board Minimum Levels (MLs) in this appendix are for use in reporting and compliance determination purposes in accordance with Section 2.4 of the State Implementation Policy. These MLs were derived from data for priority pollutants provided by State certified analytical laboratories in 1997 and 1998. These MLs shall be used until new values are adopted by the State Water Board and become effective. The following tables (Tables 2a - 2d) present MLs for four major chemical groupings: volatile substances, semi-volatile substances, inorganics, and pesticides and PCBs. The MLs in this appendix are in parts per billion (µg/L).

Table H-1 Volatile Substances

Table 2a - VOLATILE SUBSTANCES*	GC	GCMS
1,1 Dichloroethane	0.5	1
1,1 Dichloroethylene	0.5	2
1,1,1 Trichloroethane	0.5	2
1,1,2 Trichloroethane	0.5	2
1,1,2,2 Tetrachloroethane	0.5	1
1,2 Dichlorobenzene (volatile)	0.5	2
1,2 Dichloroethane	0.5	2
1,2 Dichloropropane	0.5	1
1,3 Dichlorobenzene (volatile)	0.5	2
1,3 Dichloropropene (volatile)	0.5	2
1,4 Dichlorobenzene (volatile)	0.5	2
Acrolein	2.0	5
Acrylonitrile	2.0	2
Benzene	0.5	2
Bromoform	0.5	2
Methyl Bromide	1.0	2
Carbon Tetrachloride	0.5	2
Chlorobenzene	0.5	2
Chlorodibromo-methane	0.5	2
Chloroethane	0.5	2
Chloroform	0.5	2
Chloromethane	0.5	2
Dichlorobromo-methane	0.5	2
Dichloromethane	0.5	2
Ethylbenzene	0.5	2
Tetrachloroethylene	0.5	2
Toluene	0.5	2
Trans-1,2 Dichloroethylene	0.5	1
Trichloroethene	0.5	2
Vinyl Chloride	0.5	2

*The normal method-specific factor for these substances is 1; therefore, the lowest standard concentration in the calibration curve is equal to the above ML value for each substance.

Table H-2 Semi-Volatile Substances

Table 2b - SEMI-VOLATILE SUBSTANCES*	GC	GCMS	LC	COLOR
Benzo (a) Anthracene	10	5		
1,2 Dichlorobenzene (semivolatile)	2	2		
1,2 Diphenylhydrazine		1		
1,2,4 Trichlorobenzene	1	5		
1,3 Dichlorobenzene (semivolatile)	2	1		
1,4 Dichlorobenzene (semivolatile)	2	1		
2 Chlorophenol	2	5		
2,4 Dichlorophenol	1	5		
2,4 Dimethylphenol	1	2		
2,4 Dinitrophenol	5	5		
2,4 Dinitrotoluene	10	5		
2,4,6 Trichlorophenol	10	10		
2,6 Dinitrotoluene		5		
2- Nitrophenol		10		
2-Chloroethyl vinyl ether	1	1		
2-Chloronaphthalene		10		
3,3' Dichlorobenzidine		5		
Benzo (b) Fluoranthene		10	10	
3-Methyl-Chlorophenol	5	1		
4,6 Dinitro-2-methylphenol	10	5		
4- Nitrophenol	5	10		
4-Bromophenyl phenyl ether	10	5		
4-Chlorophenyl phenyl ether		5		
Acenaphthene	1	1	0.5	
Acenaphthylene		10	0.2	
Anthracene		10	2	
Benzidine		5		
Benzo(a) pyrene		10	2	
Benzo(g,h,i)perylene		5	0.1	
Benzo(k)fluoranthene		10	2	
bis 2-(1-Chloroethoxyl) methane		5		
bis(2-chloroethyl) ether	10	1		
bis(2-Chloroisopropyl) ether	10	2		
bis(2-Ethylhexyl) phthalate	10	5		
Butyl benzyl phthalate	10	10		
Chrysene		10	5	
di-n-Butyl phthalate		10		
di-n-Octyl phthalate		10		
Dibenzo(a,h)-anthracene		10	0.1	
Diethyl phthalate	10	2		
Dimethyl phthalate	10	2		
Fluoranthene	10	1	0.05	
Fluorene		10	0.1	
Hexachloro-cyclopentadiene	5	5		

Table 2b - SEMI-VOLATILE SUBSTANCES*	GC	GCMS	LC	COLOR
Hexachlorobenzene	5	1		
Hexachlorobutadiene	5	1		
Hexachloroethane	5	1		
Indeno(1,2,3,cd)-pyrene		10	0.05	
Isophorone	10	1		
N-Nitroso diphenyl amine	10	1		
N-Nitroso-dimethyl amine	10	5		
N-Nitroso -di n-propyl amine	10	5		
Naphthalene	10	1	0.2	
Nitrobenzene	10	1		
Pentachlorophenol	1	5		
Phenanthrene		5	0.05	
Phenol **	1	1		50
Pyrene		10	0.05	

*With the exception of phenol by colorimetric technique, the normal method-specific factor for these substances is 1,000; therefore, the lowest standard concentration in the calibration curve is equal to the above ML value for each substance multiplied by 1,000.

**Phenol by colorimetric technique has a factor of 1.

Table H-3 Inorganics

Table 2c – INORGANICS*	FAA	GFAA	ICP	ICPMS	SPGFAA	HYDRIDE	CVAA	COLOR	DCP
Antimony	10	5	50	0.5	5	0.5			1,000
Arsenic		2	10	2	2	1		20	1,000
Beryllium	20	0.5	2	0.5	1				1,000
Cadmium	10	0.5	10	0.25	0.5				1,000
Chromium (total)	50	2	10	0.5	1				1,000
Chromium VI	5							10	
Copper	25	5	10	0.5	2				1,000
Cyanide								5	
Lead	20	5	5	0.5	2				10,000
Mercury				0.5			0.2		
Nickel	50	5	20	1	5				1,000
Selenium		5	10	2	5	1			1,000
Silver	10	1	10	0.25	2				1,000
Thallium	10	2	10	1	5				1,000
Zinc	20		20	1	10				1,000

*The normal method-specific factor for these substances is 1; therefore, the lowest standard concentration in the calibration curve is equal to the above ML value for each substance.

Table H-4 Pesticides and PCBs

Table 2d – PESTICIDES – PCBs*	GC
4,4'-DDD	0.05
4,4'-DDE	0.05
4,4'-DDT	0.01
a-Endosulfan	0.02
alpha-BHC	0.01
Aldrin	0.005
b-Endosulfan	0.01
Beta-BHC	0.005
Chlordane	0.1
Delta-BHC	0.005
Dieldrin	0.01
Endosulfan Sulfate	0.05
Endrin	0.01
Endrin Aldehyde	0.01
Heptachlor	0.01
Heptachlor Epoxide	0.01
Gamma-BHC (Lindane)	0.02
PCB 1016	0.5
PCB 1221	0.5
PCB 1232	0.5
PCB 1242	0.5
PCB 1248	0.5
PCB 1254	0.5
PCB 1260	0.5
Toxaphene	0.5

*The normal method-specific factor for these substances is 100; therefore, the lowest standard concentration in the calibration curve is equal to the above ML value for each substance multiplied by 100.

Techniques:

- GC - Gas Chromatography
- GCMS - Gas Chromatography/Mass Spectrometry
- HRGCMS - High Resolution Gas Chromatography/Mass Spectrometry (i.e., EPA 1613, 1624, or 1625)
- LC - High Pressure Liquid Chromatography
- FAA - Flame Atomic Absorption
- GFAA - Graphite Furnace Atomic Absorption
- HYDRIDE - Gaseous Hydride Atomic Absorption
- CVAA - Cold Vapor Atomic Absorption
- ICP - Inductively Coupled Plasma
- ICPMS - Inductively Coupled Plasma/Mass Spectrometry
- SPGFAA - Stabilized Platform Graphite Furnace Atomic Absorption (i.e., EPA 200.9)
- DCP - Direct Current Plasma
- COLOR – Colorimetric

ATTACHMENT I – SUMMARY OF WQBELS CALCULATIONS

The WQBELS developed for this Order are summarized below and were calculated as described in the methodology summarized in Attachment F, Fact Sheet and are contained in section IV.A.1.a of this Order.

Table I-1 Summary of WQBELS Calculations

CTR #	Parameters	Human Health Calculations			Aquatic Life Calculations											Effluent Limitations	
		Organism Only			Saltwater / Freshwater												
		AMEL HH = ECA = C HH only	MDEL/ AMEL multiplier	MDEL HH	ECA acute = C acute	ECA acute multiplier	LTA acute	ECA chronic = C chronic	ECA chronic multiplier	LTA chroni c	Lowest LTA	AMEL multiplier 95	AMEL aquati c life	MDEL multiplier 99	MDEL aquatic life	AMEL	MDEL
		µg/L		µg/L	µg/L		µg/L	µg/L		µg/L	µg/L					µg/L	µg/L
6	Copper	n/a	2.01	n/a	5.78	0.32	1.86	3.73	0.53	1.97	1.86	1.55	2.88	3.11	5.78	2.9	5.8
10	Selenium	n/a	2.01	n/a	20	0.32	6.42	5	0.53	2.64	2.64	1.55	4.09	3.11	8.21	4.1	8.2

Notes:

- C = Water Quality Criteria
- HH = Human health
- AMEL = Average monthly effluent limitation
- MDEL = Maximum daily effluent limitation
- ECA = Effluent concentration allowance
- LTA = Long-term average concentration