

**CALIFORNIA REGIONAL WATER QUALITY CONTROL BOARD
LAHONTAN REGION**

2501 Lake Tahoe Boulevard, South Lake Tahoe, CA 96150
(530) 542-5400 Fax (530) 544-2271
<http://www.waterboards.ca.gov/lahontan>

**WATER QUALITY ORDER NO. R6T-2022-0057
NPDES NO. CA0103063
WDID NO. 6A180045901**

**NATIONAL POLLUTANT DISCHARGE ELIMINATION SYSTEM PERMIT
AND WASTE DISCHARGE REQUIREMENTS
FOR
BASELOAD POWER WENDEL, LLC,
WENDEL GEOTHERMAL POWER PLANT**

The following Discharger is subject to waste discharge requirements (WDRs) set forth in this Order:

Discharger **Baseload Power Wendel, LLC**
Name of Facility **Wendel Geothermal Power Plant**
Facility Address **733-015 Antola Road
Wendel, California 96136
Lassen County**

Table 1. Discharge Location

Discharge Point	Effluent Description	Discharge Point Latitude (North-South)	Discharge Point Longitude (East-West)	Receiving Water
001	Spent Geothermal Fluids	40° 21' 24"	120° 15' 23"	Wendel Hot Springs

This Order was adopted on: **November 9, 2022**
This Order shall become effective on: **Dec 10, 2022**
This Order shall expire on: **Dec 8, 2027**

The Discharger must file a Report of Waste Discharge as an application for reissuance of WDRs in accordance with Title 23, California Code of Regulations, and an application for reissuance of a National Pollutant Discharge Elimination System (NPDES) permit no later than: **180 days prior to the Order expiration date**. The U.S. Environmental Protection Agency (U.S. EPA) and the California Regional Water Quality Control Board, Lahontan Region have classified this discharge as follows: Minor discharge.

BASELOAD POWER WENDEL, LLC
WENDEL GEOTHERMAL POWER PLANT

ORDER R6T-2022-0057
NPDES NO. CA0103063

I, Michael R Plaziak, Executive Officer, do hereby certify that this Order with all attachments is a full, true, and correct copy of the Order adopted by the California Regional Water Quality Control Board, Lahontan Region, on **November 9, 2022**.



MICHAEL R. PLAZIAK, PG
EXECUTIVE OFFICER

TABLE OF CONTENTS

1. FACILITY INFORMATION 6
2. FINDINGS 6
3. DISCHARGE PROHIBITIONS 7
4. EFFLUENT LIMITATIONS AND DISCHARGE PROHIBITIONS 8
 4.1. Effluent Limitations – Discharge Point 001 8
 4.2. Land Discharge Specifications – Not Applicable 8
 4.3. Recycling Specifications – Not Applicable 8
5. RECEIVING WATER LIMITATIONS 8
 5.1. Surface Water Limitations 9
 5.2. Groundwater Limitations 11
6. PROVISIONS 12
 6.1. Standard Provisions 12
 6.2. Monitoring and Reporting Program (MRP) Requirements 14
 6.3. Special Provisions 14
7. COMPLIANCE DETERMINATION 17

TABLE OF TABLES

Table 1. Discharge Location 1
Table 2. Effluent Limitations 8

TABLE OF ATTACHMENTS

ATTACHMENT A – DEFINITIONS 1
ATTACHMENT B – MAP 1
ATTACHMENT C – FLOW SCHEMATIC 1
ATTACHMENT D – STANDARD PROVISIONS 1
ATTACHMENT E – MONITORING AND REPORTING PROGRAM E-1
ATTACHMENT F – FACT SHEET F-1
ATTACHMENT G – BEST MANAGEMENT PRACTICES PLAN REQUIREMENTS... G-1

1. FACILITY INFORMATION

Information describing the Wendel Geothermal Power Plant (Facility) is summarized on the cover page and in sections 1 and 2 of the Fact Sheet (Attachment F). Section 1 of the Fact Sheet also includes information regarding the Facility's permit application.

2. FINDINGS

The California Regional Water Quality Control Board, Lahontan Region (Lahontan Water Board), finds:

- 2.1. **Legal Authorities.** This Order serves as a Waste Discharge Requirement (WDR) pursuant to article 4, chapter 4, division 7 of the California Water Code (commencing with section 13260). This Order is also issued pursuant to section 402 of the federal Clean Water Act (CWA) and implementing regulations adopted by U.S. EPA and chapter 5.5, division 7 of the Water Code (commencing with section 13370). It shall serve as a National Pollutant Discharge Elimination System (NPDES) permit authorizing the Discharger to discharge into waters of the United States at the discharge location described in Table 1 subject to the WDRs in this Order.
- 2.2. **Background and Rationale for Requirements.** The Lahontan Water Board developed the requirements in this Order based on information submitted as part of the application, through monitoring and reporting programs, and other available information. The Fact Sheet (Attachment F), which contains background information and rationale for the requirements in this Order, is hereby incorporated into and constitutes Findings for this Order. Attachments A through E and G are also incorporated into this Order.
- 2.3. **Provisions and Requirements Implementing State Law.** The provisions/requirements in subsection 5.2 of this Order are included to implement state law only. These provisions/requirements are not required or authorized under the federal CWA; consequently, violations of these provisions/requirements are not subject to the enforcement remedies that are available for NPDES violations.
- 2.4. **The Right to Access to Clean Water.** Water Code section 106.3 states in part "...every human being has the right to safe, clean, affordable, and accessible water adequate for human consumption, cooking, and sanitary purposes." This Order does not authorize discharges to sources of drinking water and requires monitoring for potential degradation of water quality.
- 2.5. **California Environmental Quality Act.** This action to adopt an NPDES permit is statutorily exempt from the provisions of the California Environmental Quality Act (CEQA, Public Resources Code sections 21000, et seq.), pursuant to section 13389 of the Water Code.
- 2.6. **Notification of Interested Parties.** The Lahontan Water Board has notified the Discharger and interested agencies and persons of its intent to prescribe WDRs for the discharge and has provided them with an opportunity to submit their written

comments and recommendations. Details of the notification are provided in the Fact Sheet.

- 2.7. **Consideration of Public Comment.** The Lahontan Water Board, in a public meeting, heard and considered all comments pertaining to the discharge. Details of the public hearing are provided in the Fact Sheet.

THEREFORE, IT IS HEREBY ORDERED that Order No. R6T-2015-0010 is rescinded upon the effective date of this Order except for enforcement purposes, and, in order to meet the provisions contained in division 7 of the Water Code (commencing with section 13000) and regulations adopted thereunder, and the provisions of the CWA and regulations and guidelines adopted thereunder, the Discharger must comply with the requirements in this Order. This action in no way prevents the Lahontan Water Board from taking enforcement action for past violations of the previous Order.

3. DISCHARGE PROHIBITIONS

- 3.1. In accordance with the Region-wide and Unit/Area-Specific Prohibitions in section 4.1 of the *Water Quality Control Plan for the Lahontan Region* (Basin Plan), the discharger must comply with the following prohibitions unless a specific exemption is granted in writing by the Lahontan Water Board:
- 3.1.1. The discharge of waste¹ that causes violation of any narrative or numeric water quality objective contained in the Basin Plan is prohibited.
- 3.1.2 Where any numeric or narrative water quality objective contained in the Basin Plan is already being violated, the discharge of waste that causes further degradation or pollution is prohibited.
- 3.1.3. The discharge of waste that could affect the quality of waters of the state that is not authorized by the State Water Resources Control Board (State Water Board) or Lahontan Water Board through waste discharge requirements, NPDES permit, cease and desist order, certification of water quality compliance pursuant to CWA section 401, or other appropriate regulatory mechanism is prohibited.
- 3.1.4. The discharge of untreated sewage², garbage, or other solid wastes into surface waters of the Region is prohibited.
- 3.1.5. The discharge of pesticides to surface or ground waters is prohibited.
- 3.2. The discharge of waste (discharge), except to authorized discharge point Discharge Point 001, is prohibited.
- 3.3. The discharge must not cause pollution as defined in section 13050 of the Water Code, or a threatened pollution.

¹ "Waste" is defined in Water Code section 13050 subdivision (d) and includes, but is not limited to, waste earthen materials (such as soil, silt, sand, clay, rock, or other organic or mineral material).

² , "Untreated sewage" is that which exceeds secondary treatment standards of the Federal Water Pollution Control Act, which are incorporated in section 4.4 of the Basin Plan.

- 3.4. Neither the treatment nor the discharge must cause a nuisance as defined in section 13050 of the Water Code.
- 3.5. **Maximum Daily Flow.** Discharges exceeding a maximum daily flow of 1.152 million gallons per day (MGD) are prohibited.
- 3.6. **Petroleum-Based Lubricant.** The discharge of petroleum-based oil lubricants is prohibited.

4. EFFLUENT LIMITATIONS AND DISCHARGE PROHIBITIONS

4.1. Effluent Limitations – Discharge Point 001

4.1.1. Final Effluent Limitations – Discharge Point 001

Table 2. Effluent Limitations

Parameter	Units	Average Monthly	Maximum Daily	Instantaneous Minimum	Instantaneous Maximum
Arsenic, Total Recoverable	µg/L	--	270	--	--
Copper, Total Recoverable	µg/L	--	10	--	--
Lead, Total Recoverable	µg/L	--	5.8	--	--
Mercury, Total Recoverable	µg/L	--	0.31	--	--
Boron, Total Recoverable	µg/L	--	5,700	--	--
Molybdenum, Total Recoverable	µg/L	--	71	--	--

4.1.1.1. The Discharger must maintain compliance with the above effluent limitations at Discharge Point 001, with compliance measured at Monitoring Location EFF-001 as described in the Monitoring and Reporting Program, Attachment E.

4.1.2. Interim Effluent Limitations – Not Applicable

4.2. Land Discharge Specifications – Not Applicable

4.3. Recycling Specifications – Not Applicable

5. RECEIVING WATER LIMITATIONS

Receiving water limitations are based on water quality objectives contained in the Basin Plan and are a required part of this Order. The discharge must not cause the following in Wendel Hot Springs:

5.1. Surface Water Limitations

5.1.1. This Discharger must not cause a violation of any applicable water quality standard for receiving water adopted by the Lahontan Water Board or the State Water Board as required by the Federal Water Pollution Control Act and regulations adopted thereunder.

5.1.2. **Water Quality Objectives Which Apply to All Surface Waters:** These narrative and numerical water quality objectives apply to all surface waters (including wetlands) within the Lahontan Region and can be found in chapter 3 of the Basin Plan. The discharge to surface waters of flows generated within, or as a result of, the Facility must not cause a violation of the following water quality objectives for the surface waters of the Susanville Hydrologic Unit:

5.1.2.1. **Bacteria, Coliform.** Waters must not contain concentrations of coliform organisms attributable to anthropogenic sources, including human and livestock wastes. The fecal coliform concentration during any 30-day period must not exceed a log mean most probable number (MPN) of 20 per 100 mL, nor must more than 10 percent of all samples collected during any 30-day period exceed 40 MPN per 100 mL. U.S. EPA recommends that the log mean should ideally be based on a minimum of not less than five samples collected as evenly spaced as practicable during any 30-day period (Reference: *Ambient Water Quality Criteria for Bacteria – 1986*, EPA 440/5-84-002, page 2). However, a log mean concentration exceeding 20 MPN per 100 mL for any 30-day period must indicate violation of this objective even if fewer than five samples were collected.

5.1.2.2. **Biostimulatory Substances.** Waters must not contain biostimulatory substances in concentrations that promote aquatic growths to the extent that such growths cause nuisance or adversely affect the water for beneficial uses.

5.1.2.3. **Chemical Constituents.** Waters must not contain concentrations of chemical constituents in amounts that adversely affect the water for beneficial uses. The receiving water has been designated as agricultural supply (AGR) and must not contain concentrations of chemical constituents in amounts that adversely affect the water for beneficial uses (i.e., agricultural purposes).

5.1.2.4. **Color.** Waters must be free of coloration that causes nuisance or adversely affects the water for beneficial uses.

5.1.2.5. **Dissolved Oxygen.** The dissolved oxygen concentration, as percent saturation, must not be depressed by more than 10 percent, nor must the minimum dissolved oxygen concentration be less than 80 percent of saturation.

5.1.2.6. **Floating Materials.** Waters must not contain floating materials, including solids, liquids, foams, and scum, in concentrations that cause nuisance or adversely affect the water for beneficial uses. For natural high-quality waters, the concentrations of floating material must not be altered to the extent that such alterations are discernible at the 10 percent significance level.

5.1.2.7. **Nondegradation of Aquatic Communities and Populations.** All wetlands must be free of substances attributable to wastewater or other discharges that

produce adverse physiological responses in humans, animals, or plants; or that lead to the presence of undesirable or nuisance aquatic life. All wetlands must be free from activities that would substantially impair the biological community as it naturally occurs due to physical, chemical, and hydrologic processes.

- 5.1.2.8. **Oil and Grease.** Waters must not contain oils, greases, waxes, or other materials in concentrations that result in a visible film or coating on the surface of the water or on objects in the water, that cause nuisance, or that otherwise adversely affect the water for beneficial uses. For natural high quality waters, the concentration of oils, greases, or other film or coat generating substances must not be altered.
- 5.1.2.9. **Radioactivity.** Radionuclides must not be present in concentrations that are deleterious to human, plant, animal, or aquatic life or that result in the accumulation of radionuclides in the food web to an extent that presents a hazard to human, plant, animal, or aquatic life.
- 5.1.2.10. **Sediment.** The suspended sediment load and suspended sediment discharge rate of surface waters must not be altered in such a manner as to cause nuisance or adversely affect the water for beneficial uses.
- 5.1.2.11. **Settleable Materials.** Waters must not contain substances in concentrations that result in deposition of material that causes nuisance or that adversely affects the water for beneficial uses. For natural high-quality waters, the concentration of settleable materials must not be raised by more than 0.1 milliliter per liter.
- 5.1.2.12. **Suspended Material.** Waters must not contain suspended materials in concentrations that cause nuisance or that adversely affect the water for beneficial uses. For natural high-quality waters, the concentration of total suspended materials must not be altered to the extent that such alterations are discernible at the 10 percent significance level.
- 5.1.2.13. **Taste and Odor.** Waters must not contain taste or odor-producing substances in concentrations that impart undesirable tastes or odors to fish or other edible products of aquatic origin, that cause nuisance, or that adversely affect the water for beneficial uses. For naturally high-quality waters, the taste and odor must not be altered.
- 5.1.2.14. **Temperature.** The natural receiving water temperature of all waters must not be altered unless it can be demonstrated to the satisfaction of the Lahontan Water Board that such an alteration in temperature does not adversely affect the water for beneficial uses.
- 5.1.2.15. **Toxicity.** All waters must be maintained free of toxic substances in concentrations that are toxic to, or that produce detrimental physiological responses in human, plant, animal, or aquatic life. Compliance with this objective will be determined by use of indicator organisms, analyses of species diversity, population density, growth anomalies, bioassays of appropriate duration, and/or other appropriate methods as specified by the Lahontan Water Board.

The survival of aquatic life in surface waters subjected to a waste discharge, or other controllable water quality factors, must not be less than that for the same water body in areas unaffected by the waste discharge, or when necessary, for other control water that is consistent with the requirements for “experimental water” as defined in *Standard Methods for the Examination of Water and Wastewater* (American Public Health Association, et al. 2012, or subsequent editions).

5.1.2.16. **Turbidity.** Waters must be free of changes in turbidity that cause nuisance or adversely affect the water for beneficial uses. Increases in turbidity must not exceed natural levels by more than 10 percent.

5.1.3. **Water Quality Objectives Which Apply to Honey Lake:** These numerical water quality objectives apply to Honey Lake and can be found in chapter 3 of the Basin Plan. The discharge to surface waters of flows generated within, or as a result of, the Facility must not cause a violation of the following water quality objectives for the surface waters of the Honey Lake:

5.1.3.1. The average value at any given time (based on 3 samples from 3 different locations) must not exceed:

5.1.3.1.1. Arsenic (in mg/L) = $37,113 \times (\text{lake volume in acre-feet})^{-0.98418}$

5.1.3.1.2. Boron (in mg/L) = $836,820 \times (\text{lake volume in acre-feet})^{-0.98133}$

5.1.3.1.3. Molybdenum (in mg/L) = $16,667 \times (\text{lake volume in acre-feet})^{-0.97658}$

5.1.3.2. The pH (based on the average of values from at least 3 samples from 3 different locations) must not at any time be depressed below 8.0 nor raised above 10.0.

5.2. Groundwater Limitations

5.2.1. The groundwater limitations in this Order are based upon the water quality objectives contained in the Basin Plan (pages 3-13 and 3-14) and are a required part of this Order. Water quality objectives that apply to the Honey Lake Valley Basin include the following:

5.2.1.1. **Bacteria, Coliform.** In groundwaters designated as municipal and domestic supply (MUN), the median concentration of coliform organisms over any seven-day period must be less than 1.1 MPN per 100 mL.

5.2.1.2. Chemical Constituents:

5.2.1.2.1 Groundwaters designated as MUN must not contain concentrations of chemical constituents in excess of the maximum contaminant level (MCL) or secondary maximum contaminant level (SMCL) based upon drinking water standards specified in the following provisions of Title 22 of the California Code of Regulations, which are incorporated by reference into this Order: Table 64431-A (Inorganic Chemicals), Table 64431-B (Fluoride), Table 64444-A (Organic Chemicals), Table 64449- A (SMCLs-Consumer Acceptance Limits), and Table 64449-B (SMCLs-Ranges). This incorporation-by-reference

is prospective including future changes to the incorporated provisions as the changes take effect.

- 5.2.1.2.2 Groundwaters designated as AGR must not contain concentrations of chemical constituents in amounts that adversely affect the water for beneficial uses (i.e., agricultural purposes).
- 5.2.1.2.3 Groundwaters must not contain chemical constituents that adversely affect the water for beneficial uses.
- 5.2.1.3. **Radioactivity.** Groundwaters designated as MUN must not contain concentrations of radionuclides in excess of the limits specified in Table 4 of section 64443 (Radioactivity) of Title 22 of the California Code of Regulations, which is incorporated by reference into this Order. This incorporation-by-reference is prospective including future changes to the incorporated provisions as the changes take effect.
- 5.2.1.4. **Taste and Odor.** Groundwaters must not contain taste- or odor-producing substances in concentrations that cause nuisance or that adversely affect beneficial uses. For groundwaters designated as MUN, at a minimum, concentrations must not exceed adopted SMCLs specified in Table 64449-A (SMCLs-Consumer Acceptance Limits) and Table 64449-B (Secondary Maximum Contaminant Levels Ranges) of Title 22 of the California Code of Regulations, which is incorporated by reference into this Order. This incorporation-by-reference is prospective including future changes to the incorporated provisions as the changes take effect.

6. PROVISIONS

6.1. Standard Provisions

- 6.1.1. The Discharger must comply with all Standard Provisions included in Attachment D.
- 6.1.2. The Discharger must comply with the following provisions. In the event that there is any conflict, duplication, or overlap between provisions specified by this Order, the more stringent provision shall apply:
- 6.1.2.1. Surface waters as used in this Order include, but are not limited to, wetlands and live streams, either perennial or ephemeral, which flow in natural or artificial watercourses, and natural lakes and artificial impoundments of waters within the State of California.
- 6.1.2.2. Groundwaters as used in this Order include, but are not limited to, all subsurface waters being above atmospheric pressure, and the capillary fringe of these waters.
- 6.1.2.3. The requirements prescribed herein do not authorize the commission of any act causing injury to the property of another, nor protect the Discharger from liabilities under federal, state, or local laws, nor guarantee the Discharger a capacity right in the receiving waters.
- 6.1.2.4. All discharges authorized by this Order must be consistent with the terms and conditions of this Order. The discharge of any pollutant more frequently than, or

at a level in excess of, that identified and authorized by this Order shall constitute a violation of the terms and conditions of this Order.

- 6.1.2.5. Pursuant to Water Code section 13263, subdivision (g), no discharge of waste into the waters of the state, whether or not the discharge is made pursuant to waste discharge requirements, shall create a vested right to continue the discharge. All discharges of waste into waters of the state are privileges, not rights.
- 6.1.2.6. Failure to comply with this Order may constitute a violation of the Water Code and/or the CWA and is grounds for enforcement action or for permit termination, revocation and re-issuance, or modification.
- 6.1.2.7. The Discharger must take all reasonable steps to minimize or prevent any discharge in violation of this Order that has a reasonable likelihood of adversely affecting human health or the environment.
- 6.1.2.8. The Water Code and the CWA provide for civil liability and criminal penalties for violations of the Order limits including imposition of civil liability or referral to the Attorney General.
- 6.1.2.9. A copy of the NPDES permit must be kept and maintained by the Discharger and be available at all times to operating personnel.
- 6.1.2.10. Provisions of the Order are severable. If any provision of the requirements is found invalid, the remainder of the requirements must not be affected.
- 6.1.2.11. In the event the Discharger is unable to comply with any of the conditions of this Order due to:
 - 6.1.2.11.1 Breakdown or serious malfunction of water treatment equipment;
 - 6.1.2.11.2 Accidents caused by human error or negligence;
 - 6.1.2.11.3 Overflows from the system; or
 - 6.1.2.11.4 Other causes such as acts of nature.

The Discharger must notify the Lahontan Water Board Executive Officer as soon as the Discharger or the Discharger's agents have knowledge of any discharge in violation of this Order, or any emergency discharge or other discharge of water to the receiving water, in accordance with the notification requirements in the Standard Provisions for NPDES Permits, included in this Order as Attachment D, and with Water Code sections 13267 and 13383.

- 6.1.2.12. Pursuant to Water Code section 13267, subdivision (b), the Discharger must notify the Lahontan Water Board of any substantial change in the volume or character of pollutants introduced into the Facility from the conditions existing at the time of adoption of this Order.
- 6.1.2.13. Adequate notice must include information on the quality and quantity of effluent discharged into the receiving waters for the Facility, as well as any anticipated impact of the change on the quantity or quality of the effluent to be discharged from the Facility. A substantial change in volume is considered an

increase in excess of 10 percent of the mean daily flow rate. The Discharger must forward a copy of such notice directly to the U.S. EPA Regional Administrator.

- 6.1.2.14. The Discharger must file a Report of Waste Discharge (ROWD) with the Lahontan Water Board at least 180 days before making any material change or proposed change in the character, location, or volume of the discharge.
- 6.1.2.15. Pursuant to Water Code section 13260, subdivision (c), any change in the ownership and/or operation of property subject to the NPDES Permit must be reported to the Lahontan Water Board within 10 days of the change. Notification of applicable NPDES Permit requirements must be furnished in writing to the new owners and/or operators, and a copy of such notification must be sent to the Lahontan Water Board within 10 days of the change.
- 6.1.2.16. If a Discharger becomes aware that any information submitted to the Lahontan Water Board is incorrect, the Discharger must immediately notify the Lahontan Water Board, in writing, and correct that information.
- 6.1.2.17. If the Discharger becomes aware that its NPDES Permit is no longer needed (because the discharge will cease), the Discharger must notify the Lahontan Water Board in writing within 10 days and request that the Order be rescinded.
- 6.1.2.18. Failure to comply with provisions or requirements of this Order, or violation of other applicable laws or regulations governing discharges from this facility, may subject the Discharger to administrative or civil liabilities, criminal penalties, and/or other enforcement remedies to ensure compliance. Additionally, certain violations may subject the Discharger to civil or criminal enforcement from appropriate local, state, or federal law enforcement entities.
- 6.1.2.19. In the event the Discharger does not comply or will be unable to comply for any reason, with any prohibition, maximum daily effluent limitation, or receiving water limitation of this Order, the Discharger must notify the Lahontan Water Board by telephone (530) 542-5400 within 24 hours of having knowledge of such noncompliance and must confirm this notification in writing within five days, unless the Lahontan Water Board waives confirmation. The written notification must state the nature, time, duration, and cause of noncompliance, and must describe the measures being taken to remedy the current noncompliance and prevent recurrence including, where applicable, a schedule of implementation. Other noncompliance requires written notification as above at the time of the normal monitoring report.

6.2. Monitoring and Reporting Program (MRP) Requirements

The Discharger must comply with the MRP, and future revisions thereto, in Attachment E.

6.3. Special Provisions

6.3.1. Reopener Provisions

- 6.3.1.1. If more stringent applicable water quality standards are promulgated or approved pursuant to section 303 of the Federal Water Pollution Control Act or

amendments thereto, the Lahontan Water Board may revise and modify this Order in accordance with such more stringent standards.

6.3.1.2. The Lahontan Water Board may reopen this Order to establish new conditions or effluent limitations should monitoring data, toxicity testing data, or other new information indicate that a constituent is discharged at a level that will do any of the following:

6.3.1.2.1. Cause, have reasonable potential to cause, or contribute to an in-stream excursion above any water quality criteria or objective, or

6.3.1.2.2. Cause, have reasonable potential to cause, or contribute to a violation of any narrative water quality objective contained in the Basin Plan.

6.3.1.3. **Intake Water Credits.** The Discharger submitted information as detailed in section 1.4.4 of the *Policy for Implementation of Toxics Standards for Inland Surface Waters, Enclosed Bays, and Estuaries of California* (SIP) demonstrating that the required conditions are met for intake water credits. As the SIP conditions were met, the Lahontan Water Board included effluent limitations based on the 99th percentile value representing the upper range of the variability between intake and effluent pollutant concentrations, not to exceed the maximum observed intake concentration, due to sampling and analysis variability. To the extent that the characteristics of the influent (and subsequently the effluent) change, the effluent limitations specified in this Order may be modified, if new information is submitted by the Discharger to the Lahontan Water Board.

6.3.2. **Special Studies, Technical Papers and Additional Monitoring Requirements**

6.3.2.1. **Intake Water Credit Summary Report for Copper, Lead, and Mercury**

During the term of this permit, the Discharger must conduct a study to confirm conditions for intake water credits in accordance with Section 1.4.4 of the SIP, and prepare a report that will provide the Lahontan Water Board with the data to evaluate the applicability of intake credits to the Facility's discharge for the next permit issuance, reissuance, or renewal. At a minimum and to the satisfaction of the Lahontan Water Board, the report must address the following conditions for intake water credits as detailed in section 1.4.4 of the SIP for copper, lead, and mercury:

1. *"The observed maximum ambient background concentration, as determined in section 1.4.3.1, and the intake water concentration of the pollutant exceeds the most stringent applicable criterion/objective for that pollutant;*
2. *The intake water credits provided are consistent with any TMDL applicable to the discharge that has been approved by the RWQCB, SWRCB, and U.S. EPA;*
3. *The intake water is from the same water body as the receiving water body. The discharger may demonstrate this condition by showing that:*

- a. *the ambient background concentration of the pollutant in the receiving water, excluding any amount of the pollutant in the facility's discharge, is similar to that of the intake water;*
- b. *there is a direct hydrological connection between the intake and discharge points;*
- c. *the water quality characteristics are similar in the intake and receiving waters; and*
- d. *the intake water pollutant would have reached the vicinity of the discharge point in the receiving water within a reasonable period of time and with the same effect had it not been diverted by the discharger.*

The RWQCB may also consider other factors when determining whether the intake water is from the same water body as the receiving water body;

4. *The facility does not alter the intake water pollutant chemically or physically in a manner that adversely affects water quality and beneficial uses; and*
5. *The timing and location of the discharge does not cause adverse effects on water quality and beneficial uses that would not occur if the intake water pollutant had been left in the receiving water body."*

Lahontan Water Board will consider all historical and current water quality data of the ambient Wendel Hots Springs towards granting intake credits. If the Discharger has or knows of any additional information that it wishes to be considered, please provide that information within this report. The intake credit summary report must be submitted to the Lahontan Water Board no later than **November 9, 2024**.

6.3.3. Best Management Practices and Pollution Prevention

6.3.3.1. Best Management Practices Plan. The Discharger must develop and implement a Best Management Practices (BMP) Plan that includes site-specific plans and procedures implemented and/or to be implemented to prevent the generation and potential release of additional pollutants from the Facility to waters of the state. The BMP Plan must particularly focus on the area and processes associated with the geothermal power plant and be developed in accordance with the requirements contained in Attachment G to this Order. The BMP Plan must be developed to prevent the introduction of chemicals or other substances into the effluent from the Facility and prevent the addition of pollutants from the other non-permitted process waters, spills, or other sources of pollutants at the Facility.

The BMP Plan must be developed and implemented as soon as possible, but no later than 120 days from the effective date of this Order. The Discharger must also submit a copy of the BMP Plan to the Executive Officer within 120 days from the effective date of this Order.

6.3.4. Construction, Operation and Maintenance Specifications – Not Applicable

.6.3.5. Special Provisions for Publicly-Owned Treatment Works (POTWs) – Not Applicable

6.3.6. Other Special Provisions – Not Applicable

6.3.7. Compliance Schedules – Not Applicable

7. COMPLIANCE DETERMINATION

7.1. Multiple Sample Data

When determining compliance with a maximum daily effluent limitation (MDEL) and more than one sample result is available, the Discharger must compute the arithmetic mean unless the data set contains one or more reported determinations of “Detected, but Not Quantified” (DNQ) or “Not Detected” (ND). In those cases, the Discharger must compute the median in place of the arithmetic mean in accordance with the following procedure:

- 7.1.1. The data set shall be ranked from low to high, ranking the reported ND determinations lowest, DNQ determinations next, followed by quantified values (if any). The order of the individual ND or DNQ determinations is unimportant.
- 7.1.2. The median value of the data set must be determined. If the data set has an odd number of data points, then the median is the middle value. If the data set has an even number of data points, then the median is the average of the two values around the middle unless one or both of the points are ND or DNQ, in which case the median value must be the lower of the two data points where DNQ is lower than a value and ND is lower than DNQ.

7.2. Limitation Bases

7.2.1. Maximum Daily Effluent Limitation (MDEL)

If a daily discharge exceeds the MDEL for a given parameter, the Discharger will be considered out of compliance for that parameter for that one day only within the reporting period. For any one day during which no sample is taken, no compliance determination can be made for that calendar day.

ATTACHMENT A – DEFINITIONS

Arithmetic Mean (μ)

Also called the average, is the sum of measured values divided by the number of samples. For ambient water concentrations, the arithmetic mean is calculated as follows:

$$\text{Arithmetic mean } (\mu) = \frac{\sum x}{n}$$

where: $\sum x$ is the sum of the measured ambient water concentrations, and n is the number of samples.

Average Monthly Effluent Limitation (AMEL)

The highest allowable average of daily discharges over a calendar month, calculated as the sum of all daily discharges measured during a calendar month divided by the number of daily discharges measured during that month.

Average Weekly Effluent Limitation (AWEL)

The highest allowable average of daily discharges over a calendar week (Sunday through Saturday), calculated as the sum of all daily discharges measured during a calendar week divided by the number of daily discharges measured during that week.

Best Management Practices (BMPs)

Schedules of activities, prohibitions of practices, maintenance procedures, and other management practices to prevent or reduce the pollution of surface waters. BMPs also include treatment requirements, operating procedures, and practices to control site runoff, spillage or leaks, and solids or waste disposal.

Bioaccumulative

Those substances taken up by an organism from its surrounding medium through gill membranes, epithelial tissue, or from food and subsequently concentrated and retained in the body of the organism.

Carcinogenic

Pollutants are substances that are known to cause cancer in living organisms.

Coefficient of Variation (CV)

CV is a measure of the data variability and is calculated as the estimated standard deviation divided by the arithmetic mean of the observed values.

Daily Discharge

Daily Discharge is defined as either: (1) the total mass of the constituent discharged over the calendar day (12:00 am through 11:59 pm) or any 24-hour period that reasonably represents a calendar day for purposes of sampling (as specified in the permit), for a constituent with limitations expressed in units of mass or; (2) the unweighted arithmetic mean measurement of the constituent over the day for a constituent with limitations expressed in other units of measurement (e.g., concentration).

The daily discharge may be determined by the analytical results of a composite sample taken over the course of one day (a calendar day or other 24-hour period defined as a day) or by the arithmetic mean of analytical results from one or more grab samples taken over the course of the day.

For composite sampling, if 1 day is defined as a 24-hour period other than a calendar day, the analytical result for the 24-hour period will be considered as the result for the calendar day in which the 24-hour period ends.

Detected, but Not Quantified (DNQ)

DNQ are those sample results less than the RL, but greater than or equal to the laboratory's MDL. Sample results reported as DNQ are estimated concentrations.

Dilution Credit

Dilution Credit is the amount of dilution granted to a discharge in the calculation of a water quality-based effluent limitation, based on the allowance of a specified mixing zone. It is calculated from the dilution ratio or determined through conducting a mixing zone study or modeling of the discharge and receiving water.

Effluent Concentration Allowance (ECA)

ECA is a value derived from the water quality criterion/objective, dilution credit, and ambient background concentration that is used, in conjunction with the coefficient of variation for the effluent monitoring data, to calculate a long-term average (LTA) discharge concentration. The ECA has the same meaning as wasteload allocation (WLA) as used in U.S. EPA guidance (Technical Support Document For Water Quality-based Toxics Control, March 1991, second printing, EPA/505/2-90-001).

Enclosed Bays

Enclosed Bays means indentations along the coast that enclose an area of oceanic water within distinct headlands or harbor works. Enclosed bays include all bays where the narrowest distance between the headlands or outermost harbor works is less than 75 percent of the greatest dimension of the enclosed portion of the bay. Enclosed bays include, but are not limited to, Humboldt Bay, Bodega Harbor, Tomales Bay, Drake's Estero, San Francisco Bay, Morro Bay, Los Angeles-Long Beach Harbor, Upper and Lower Newport Bay, Mission Bay, and San Diego Bay. Enclosed bays do not include inland surface waters or ocean waters.

Estimated Chemical Concentration

The estimated chemical concentration that results from the confirmed detection of the substance by the analytical method below the ML value.

Estuaries

Estuaries means waters, including coastal lagoons, located at the mouths of streams that serve as areas of mixing for fresh and ocean waters. Coastal lagoons and mouths of streams that are temporarily separated from the ocean by sandbars shall be considered estuaries. Estuarine waters shall be considered to extend from a bay or the open ocean to a point upstream where there is no significant mixing of fresh water and

seawater. Estuarine waters included, but are not limited to, the Sacramento-San Joaquin Delta, as defined in Water Code section 12220, Suisun Bay, Carquinez Strait downstream to the Carquinez Bridge, and appropriate areas of the Smith, Mad, Eel, Noyo, Russian, Klamath, San Diego, and Otay rivers. Estuaries do not include inland surface waters or ocean waters.

Inland Surface Waters

All surface waters of the state that do not include the ocean, enclosed bays, or estuaries.

Instantaneous Maximum Effluent Limitation

The highest allowable value for any single grab sample or aliquot (i.e., each grab sample or aliquot is independently compared to the instantaneous maximum limitation).

Instantaneous Minimum Effluent Limitation

The lowest allowable value for any single grab sample or aliquot (i.e., each grab sample or aliquot is independently compared to the instantaneous minimum limitation).

Maximum Daily Effluent Limitation (MDEL)

The highest allowable daily discharge of a pollutant, over a calendar day (or 24-hour period). For pollutants with limitations expressed in units of mass, the daily discharge is calculated as the total mass of the pollutant discharged over the day. For pollutants with limitations expressed in other units of measurement, the daily discharge is calculated as the arithmetic mean measurement of the pollutant over the day.

Median

The middle measurement in a set of data. The median of a set of data is found by first arranging the measurements in order of magnitude (either increasing or decreasing order)

If the number of measurements (n) is odd, then:

$$\text{median} = \frac{X_{(n+1)}}{2}$$

If n is even, then:

$$\text{median} = \frac{X_{\frac{n}{2}} + X_{\frac{n}{2}+1}}{2}$$

(i.e., the midpoint between the (n/2 and ((n/2)+1))).

Method Detection Limit (MDL)

MDL is the minimum concentration of a substance that can be reported with 99 percent confidence that the measured concentration is distinguishable from method blank results, as defined in 40 Code of Federal Regulations (C.F.R.). part 136, Attachment B.

Minimum Level (ML)

ML is the concentration at which the entire analytical system must give a recognizable signal and acceptable calibration point. The ML is the concentration in a sample that is equivalent to the concentration of the lowest calibration standard analyzed by a specific analytical procedure, assuming that all the method specified sample weights, volumes, and processing steps have been followed.

Mixing Zone

Mixing Zone is a limited volume of receiving water that is allocated for mixing with a wastewater discharge where water quality criteria can be exceeded without causing adverse effects to the overall water body.

Not Detected (ND)

Sample results which are less than the laboratory's MDL.

Persistent Pollutants

Persistent pollutants are substances for which degradation or decomposition in the environment is nonexistent or very slow.

Pollutant Minimization Program (PMP)

PMP means waste minimization and pollution prevention actions that include, but are not limited to, product substitution, waste stream recycling, alternative waste management methods, and education of the public and businesses. The goal of the PMP shall be to reduce all potential sources of a priority pollutant(s) through pollutant minimization (control) strategies, including pollution prevention measures as appropriate, to maintain the effluent concentration at or below the water quality-based effluent limitation. Pollution prevention measures may be particularly appropriate for persistent bioaccumulative priority pollutants where there is evidence that beneficial uses are being impacted. The Lahontan Water Board may consider cost effectiveness when establishing the requirements of a PMP. The completion and implementation of a Pollution Prevention Plan, if required pursuant to Water Code section 13263.3(d), shall be considered to fulfill the PMP requirements.

Pollution Prevention

Pollution Prevention means any action that causes a net reduction in the use or generation of a hazardous substance or other pollutant that is discharged into water and includes, but is not limited to, input change, operational improvement, production process change, and product reformulation (as defined in Water Code section 13263.3). Pollution prevention does not include actions that merely shift a pollutant in wastewater from one environmental medium to another environmental medium, unless clear environmental benefits of such an approach are identified to the satisfaction of the State Water Resources Control Board (State Water Board) or Lahontan Water Board.

Reporting Level (RL)

The RL is the ML (and its associated analytical method) chosen by the Discharger for reporting and compliance determination from the MLs included in this Order, including an additional factor if applicable as discussed herein. The MLs included in this Order

correspond to approved analytical methods for reporting a sample result that are selected by the Lahontan Water Board either from Appendix 4 of the SIP in accordance with section 2.4.2 of the SIP or established in accordance with section 2.4.3 of the SIP. The ML is based on the proper application of method-based analytical procedures for sample preparation and the absence of any matrix interferences. Other factors may be applied to the ML depending on the specific sample preparation steps employed. For example, the treatment typically applied in cases where there are matrix-effects is to dilute the sample or sample aliquot by a factor of ten. In such cases, this additional factor must be applied to the ML in the computation of the RL.

Source of Drinking Water

Any water designated as municipal or domestic supply (MUN) in a Lahontan Water Board Basin Plan.

Standard Deviation (σ)

Standard Deviation is a measure of variability that is calculated as follows:

$$\text{Standard Deviation } (\sigma) = \frac{\sum(X-\mu)^2}{(n-1)^{0.5}}$$

where: x is the observed value; μ is the arithmetic mean of the observed values; and n is the number of samples.

Toxicity Reduction Evaluation (TRE)

TRE is a study conducted in a step-wise process designed to identify the causative agents of effluent or ambient toxicity, isolate the sources of toxicity, evaluate the effectiveness of toxicity control options, and then confirm the reduction in toxicity. The first steps of the TRE consist of the collection of data relevant to the toxicity, including additional toxicity testing, and an evaluation of facility operations and maintenance practices, and best management practices. A Toxicity Identification Evaluation (TIE) may be required as part of the TRE, if appropriate. (A TIE is a set of procedures to identify the specific chemical(s) responsible for toxicity. These procedures are performed in three phases (characterization, identification, and confirmation) using aquatic organism toxicity tests.)

ATTACHMENT B – MAP

Figure B-1. Wendel Geothermal Power Plant Overview Map

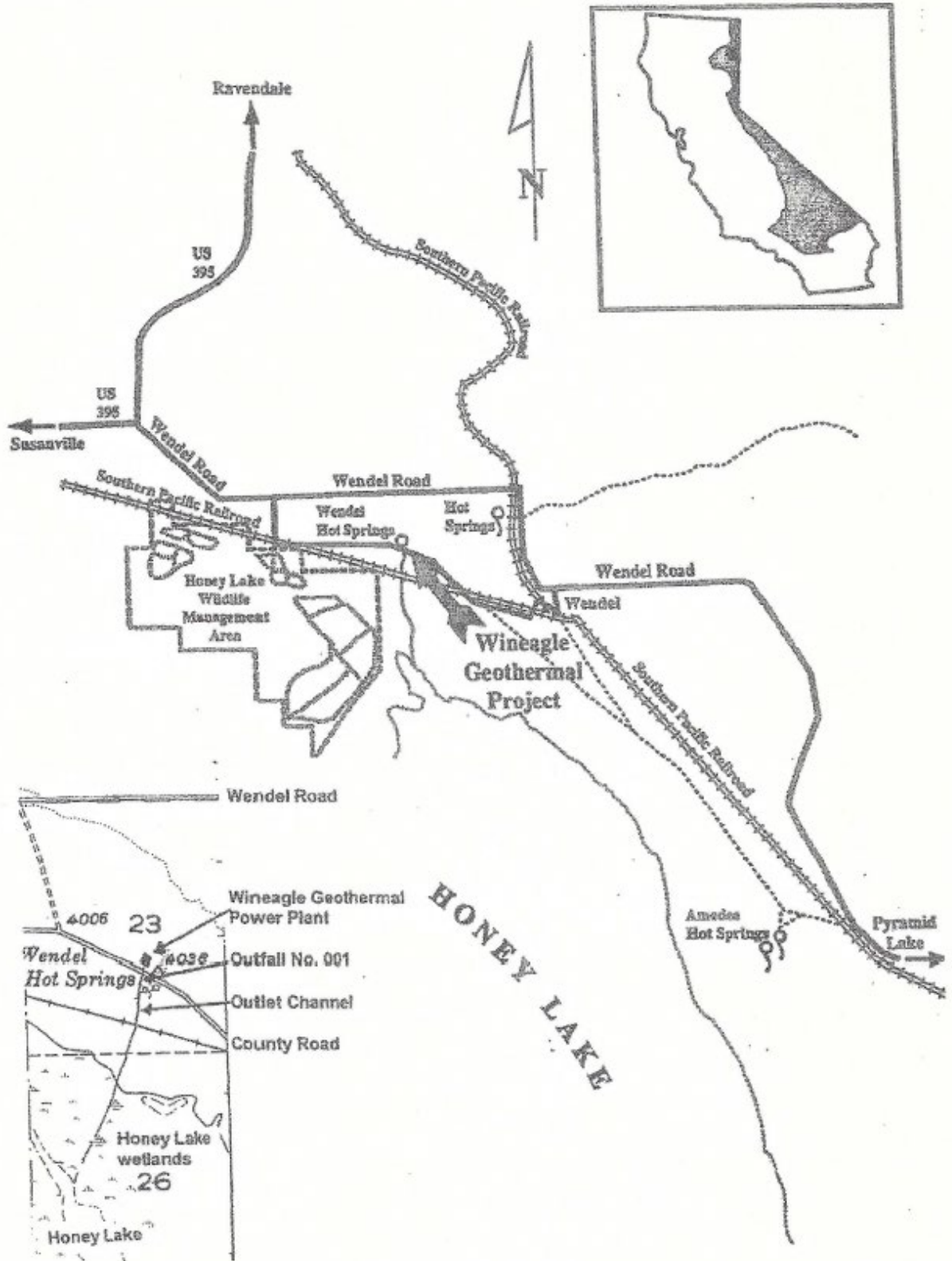
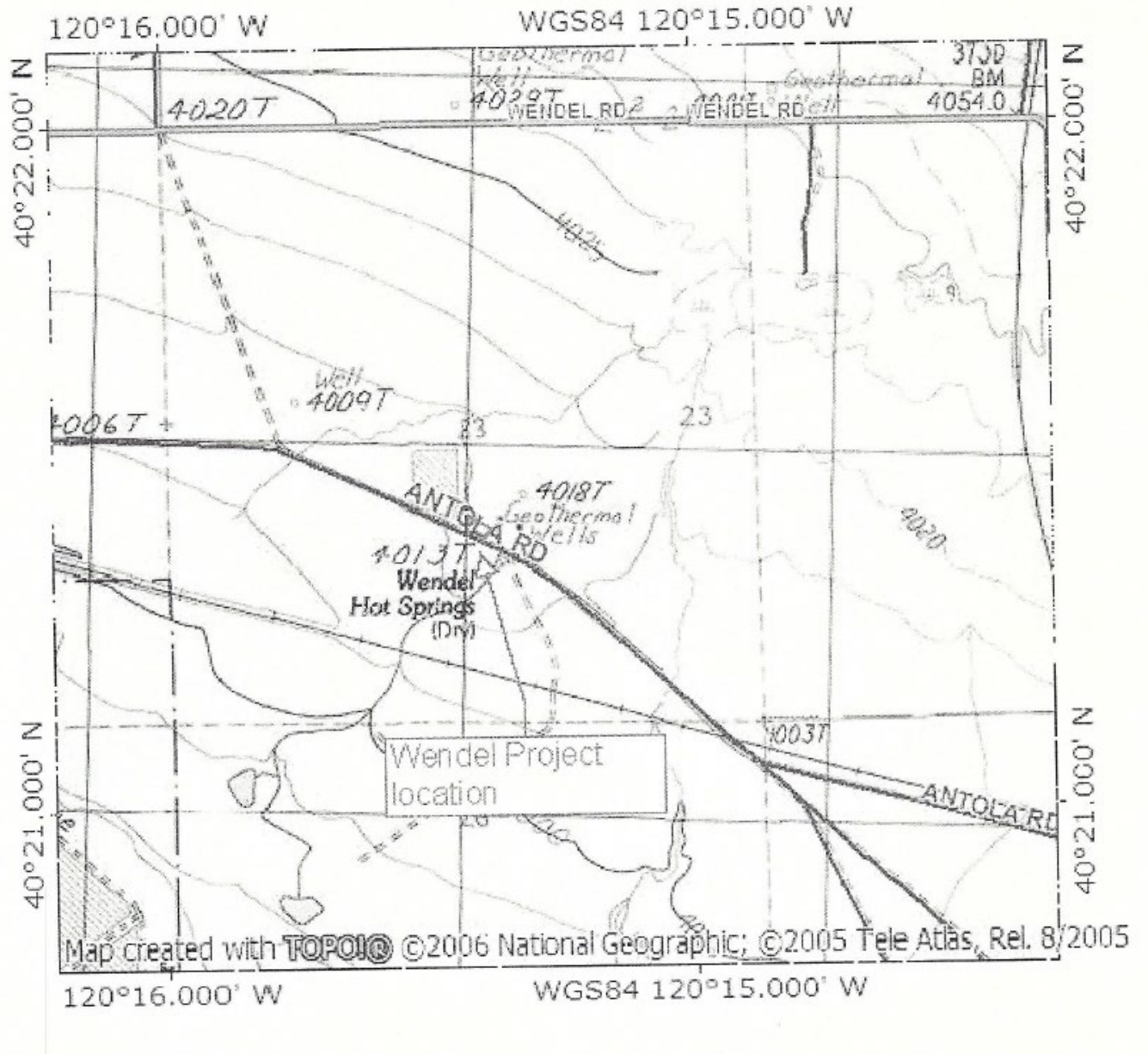

Figure B-2. Wendel Geothermal Power Plant Topographical Map



ATTACHMENT C – FLOW SCHEMATIC

Figure C-1. Wendel Geothermal Power Plant Wastewater Flow Schematic

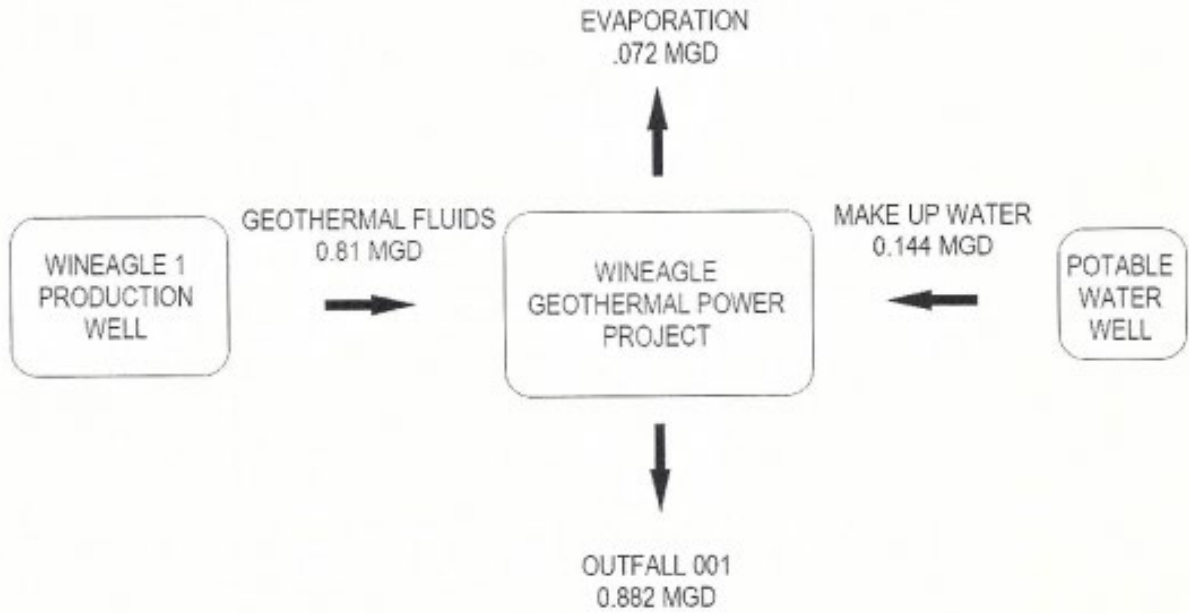
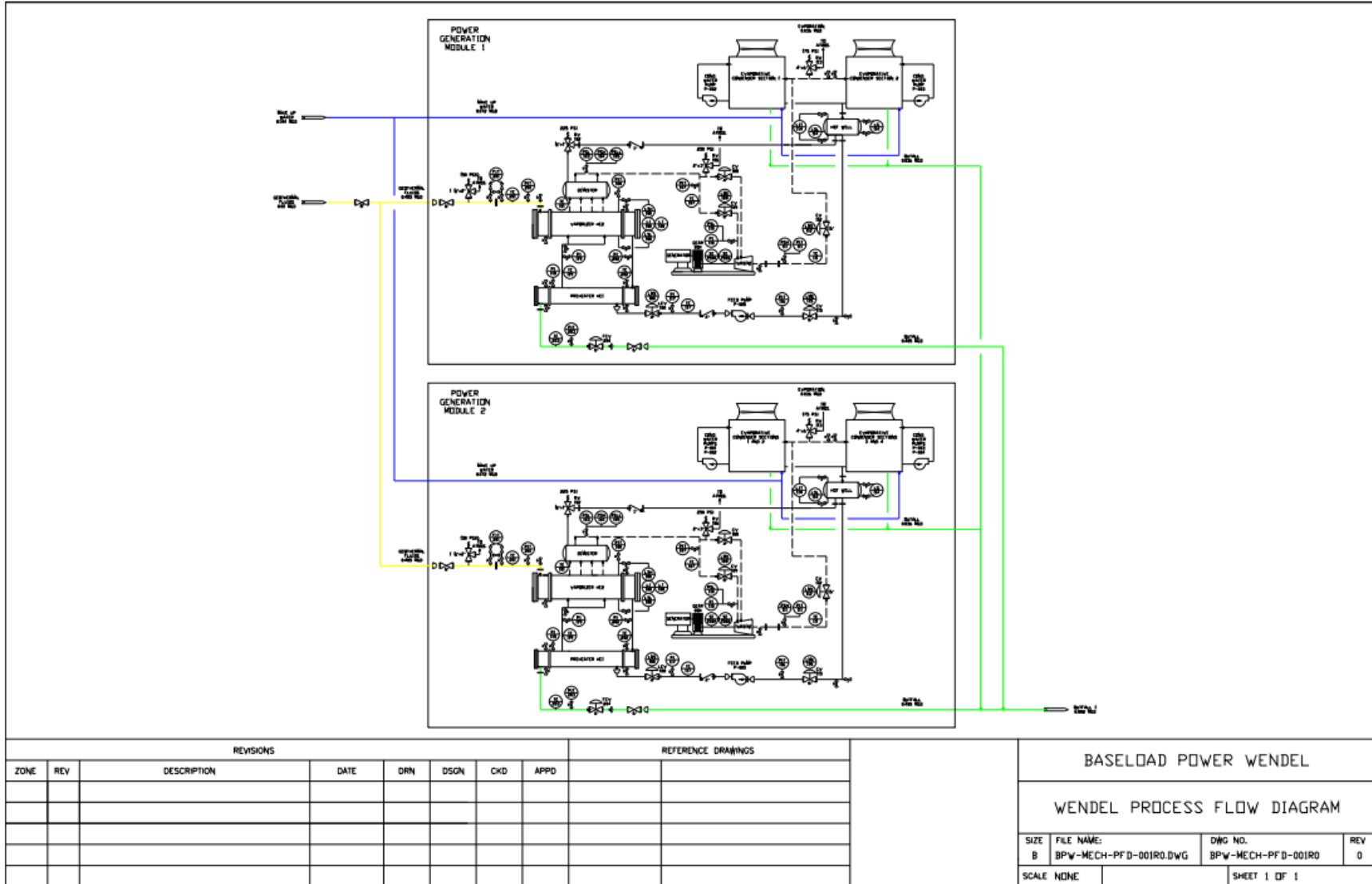

Figure C-2. Wendel Geothermal Power Plant Process Flow Diagram



ATTACHMENT D – STANDARD PROVISIONS

1. STANDARD PROVISIONS – PERMIT COMPLIANCE

1.1. Duty to Comply

- 1.1.1. The Discharger must comply with all of the terms, requirements, and conditions of this Order. Any noncompliance constitutes a violation of the Clean Water Act (CWA) and the California Water Code and is grounds for enforcement action; permit termination, revocation and reissuance, or modification; denial of a permit renewal application; or a combination thereof. (40 Code of Federal Regulations (C.F.R.) § 122.41(a); Wat. Code, §§ 13261, 13263, 13265, 13268, 13000, 13001, 13304, 13350, 13385)
- 1.1.2. The Discharger must comply with effluent standards or prohibitions established under Section 307(a) of the CWA for toxic pollutants within the time provided in the regulations that establish these standards or prohibitions, even if this Order has not yet been modified to incorporate the requirement. (40 C.F.R. § 122.41(a)(1))

1.2. Need to Halt or Reduce Activity Not a Defense

It shall not be a defense for a Discharger in an enforcement action that it would have been necessary to halt or reduce the permitted activity in order to maintain compliance with the conditions of this Order. (40 C.F.R. § 122.41(c))

1.3. Duty to Mitigate

The Discharger must take all reasonable steps to minimize or prevent any discharge in violation of this Order that has a reasonable likelihood of adversely affecting human health or the environment. (40 C.F.R. § 122.41(d))

1.4. Proper Operation and Maintenance

The Discharger must at all times properly operate and maintain all facilities and systems of treatment and control (and related appurtenances) which are installed or used by the Discharger to achieve compliance with the conditions of this Order. Proper operation and maintenance also include adequate laboratory controls and appropriate quality assurance procedures. This provision requires the operation of backup or auxiliary facilities or similar systems that are installed by a Discharger only when necessary to achieve compliance with the conditions of this Order. (40 C.F.R. § 122.41(e))

1.5. Property Rights

- 1.5.1. This Order does not convey any property rights of any sort or any exclusive privileges. (40 C.F.R. § 122.41(g))
- 1.5.2. The issuance of this Order does not authorize any injury to persons or property or invasion of other private rights, or any infringement of state or local law or regulations. (40 C.F.R. § 122.5(c))

1.6. Inspection and Entry

The Discharger must allow the Lahontan Water Board, State Water Board, U.S. EPA, and/or their authorized representatives (including an authorized contractor acting as their representative), upon the presentation of credentials and other documents, as may be required by law, to (33 U.S.C. § 1318(a)(4)(B); 40 C.F.R. § 122.41(i); Wat. Code, §§ 13267, 13383):

- 1.6.1. Enter upon the Discharger's premises where a regulated facility or activity is located or conducted, or where records are kept under the conditions of this Order (33 U.S.C. § 1318(a)(4)(B)(i); 40 C.F.R. § 122.41(i)(1); Wat. Code, §§ 13267, 13383);
- 1.6.2. Have access to and copy, at reasonable times, any records that must be kept under the conditions of this Order (33 U.S.C. § 1318(a)(4)(B)(ii); 40 C.F.R. § 122.41(i)(2); Wat. Code, §§ 13267, 13383);
- 1.6.3. Inspect and photograph, at reasonable times, any facilities, equipment (including monitoring and control equipment), practices, or operations regulated or required under this Order (33 U.S.C. § 1318(a)(4)(B)(ii); 40 C.F.R. § 122.41(i)(3); Wat. Code, §§ 13267, 13383); and
- 1.6.4. Sample or monitor, at reasonable times, for the purposes of assuring Order compliance or as otherwise authorized by the CWA or the Water Code, any substances or parameters at any location. (33 U.S.C. § 1318(a)(4)(B); 40 C.F.R. § 122.41(i)(4); Wat. Code, §§ 13267, 13383)

1.7. Bypass

1.7.1. Definitions

- 1.7.1.1. "Bypass" means the intentional diversion of waste streams from any portion of a treatment facility. (40 C.F.R. § 122.41(m)(1)(i))
- 1.7.1.2. "Severe property damage" means substantial physical damage to property, damage to the treatment facilities, which causes them to become inoperable, or substantial and permanent loss of natural resources that can reasonably be expected to occur in the absence of a bypass. Severe property damage does not mean economic loss caused by delays in production. (40 C.F.R. § 122.41(m)(1)(ii))
- 1.7.2. **Bypass not exceeding limitations.** The Discharger may allow any bypass to occur which does not cause exceedances of effluent limitations, but only if it is for essential maintenance to assure efficient operation. These bypasses are not subject to the provisions listed in Standard Provisions – Permit Compliance 1.7.3, 1.7.4, and 1.7.5 below. (40 C.F.R. § 122.41(m)(2))
- 1.7.3. **Prohibition of bypass.** Bypass is prohibited, and the Lahontan Water Board may take enforcement action against a Discharger for bypass, unless (40 C.F.R. § 122.41(m)(4)(i)):
 - 1.7.3.1. Bypass was unavoidable to prevent loss of life, personal injury, or severe property damage (40 C.F.R. § 122.41(m)(4)(i)(A));

- 1.7.3.2. There were no feasible alternatives to the bypass, such as the use of auxiliary treatment facilities, retention of untreated wastes, or maintenance during normal periods of equipment downtime. This condition is not satisfied if adequate back up equipment should have been installed in the exercise of reasonable engineering judgment to prevent a bypass that occurred during normal periods of equipment downtime or preventive maintenance (40 C.F.R. § 122.41(m)(4)(i)(B)); and
- 1.7.3.3. The Discharger submitted notice to the Lahontan Water Board as required under Standard Provisions – Permit Compliance 1.7.5 below. (40 C.F.R. § 122.41(m)(4)(i)(C).)
- 1.7.4. The Lahontan Water Board may approve an anticipated bypass, after considering its adverse effects, if the Lahontan Water Board determines that it will meet the three conditions listed in Standard Provisions – Permit Compliance 1.7.3 above. (40 C.F.R. § 122.41(m)(4)(ii))

1.7.5. Notice

- 1.7.5.1. **Anticipated bypass.** If the Discharger knows in advance of the need for a bypass, it must submit prior notice, if possible, at least 10 days before the date of the bypass. The notice shall be sent to the Lahontan Water Board. As of December 21, 2023, all notices must be submitted electronically to the initial recipient defined in Standard Provisions – Reporting 5.10 below. Notices shall comply with 40 C.F.R. part 3, 40 C.F.R. section 122.22, and 40 C.F.R. part 127. (40 C.F.R. § 122.41(m)(3)(i))
- 1.7.5.2. **Unanticipated bypass.** The Discharger must submit a notice of an unanticipated bypass as required in Standard Provisions - Reporting V.E below (24-hour notice). The notice must be sent to the Lahontan Water Board. As of December 21, 2023, all notices must be submitted electronically to the initial recipient defined in Standard Provisions – Reporting 5.10 below. Notices must comply with 40 C.F.R. part 3, 40 C.F.R. section 122.22, and 40 C.F.R. part 127. (40 C.F.R. § 122.41(m)(3)(ii))

1.8. Upset

Upset means an exceptional incident in which there is unintentional and temporary noncompliance with technology-based permit effluent limitations because of factors beyond the reasonable control of the Discharger. An upset does not include noncompliance to the extent caused by operational error, improperly designed treatment facilities, inadequate treatment facilities, lack of preventive maintenance, or careless or improper operation. (40 C.F.R. § 122.41(n)(1))

- 1.8.1. **Effect of an upset.** An upset constitutes an affirmative defense to an action brought for noncompliance with such technology-based permit effluent limitations if the requirements of Standard Provisions – Permit Compliance 1.8.2 below are met. No determination made during administrative review of claims that noncompliance was caused by upset, and before an action for noncompliance, is final administrative action subject to judicial review. (40 C.F.R. § 122.41(n)(2))

- 1.8.2 **Conditions necessary for a demonstration of upset.** A Discharger who wishes to establish the affirmative defense of upset must demonstrate, through properly signed, contemporaneous operating logs or other relevant evidence that (40 C.F.R. § 122.41(n)(3)):
- 1.8.2.1. An upset occurred and that the Discharger can identify the cause(s) of the upset (40 C.F.R. § 122.41(n)(3)(i));
 - 1.8.2.2. The permitted facility was, at the time, being properly operated (40 C.F.R. § 122.41(n)(3)(ii));
 - 1.8.2.3. The Discharger submitted notice of the upset as required in Standard Provisions – Reporting 5.5.2.2 below (24-hour notice) (40 C.F.R. § 122.41(n)(3)(iii)); and
 - 1.8.2.4. The Discharger complied with any remedial measures required under Standard Provisions – Permit Compliance 1.3 above. (40 C.F.R. § 122.41(n)(3)(iv))
- 1.8.3. **Burden of proof.** In any enforcement proceeding, the Discharger seeking to establish the occurrence of an upset has the burden of proof. (40 C.F.R. § 122.41(n)(4))

2. STANDARD PROVISIONS – PERMIT ACTION

2.1. General

This Order may be modified, revoked and reissued, or terminated for cause. The filing of a request by the Discharger for modification, revocation and reissuance, or termination, or a notification of planned changes or anticipated noncompliance does not stay any Order condition. (40 C.F.R. § 122.41(f))

2.2. Duty to Reapply

If the Discharger wishes to continue an activity regulated by this Order after the expiration date of this Order, the Discharger must apply for and obtain a new permit. (40 C.F.R. § 122.41(b))

2.3. Transfers

This Order is not transferable to any person except after notice to the Lahontan Water Board. The Lahontan Water Board may require modification or revocation and reissuance of the Order to change the name of the Discharger and incorporate such other requirements as may be necessary under the CWA and the Water Code. (40 C.F.R. §§ 122.41(l)(3), 122.61)

3. STANDARD PROVISIONS – MONITORING

- 3.1. Samples and measurements taken for the purpose of monitoring must be representative of the monitored activity. (40 C.F.R. § 122.41(j)(1))
- 3.2. Monitoring must be conducted according to test procedures approved under 40 C.F.R. part 136 for the analyses of pollutants unless another method is required under 40 C.F.R. chapter 1, subchapter N. Monitoring must be conducted according to sufficiently sensitive test methods approved under 40 C.F.R. part 136 for the

analysis of pollutants or pollutant parameters or as required under 40 C.F.R. chapter 1, subchapter N. For the purposes of this paragraph, a method is sufficiently sensitive when:

- 3.2.1. The method minimum level (ML) is at or below the level of the most stringent effluent limitation established in the permit for the measured pollutant or pollutant parameter, and either the method ML is at or below the level of the most stringent applicable water quality criterion for the measured pollutant or pollutant parameter or the method ML is above the applicable water quality criterion but the amount of the pollutant or pollutant parameter in the facility's discharge is high enough that the method detects and quantifies the level of the pollutant or pollutant parameter in the discharge; or
- 3.2.2. The method has the lowest ML of the analytical methods approved under 40 C.F.R. part 136 or required under 40 C.F.R. chapter 1, subchapter N for the measured pollutant or pollutant parameter. In the case of pollutants or pollutant parameters for which there are no approved methods under 40 C.F.R. part 136, or otherwise required under 40 C.F.R. chapter 1, subchapter N, monitoring must be conducted according to a test procedure specified in this Order for such pollutants or pollutant parameters. (40 C.F.R. §§ 122.21(e)(3), 122.41(j)(4), 122.44(i)(1)(iv))

4. STANDARD PROVISIONS – RECORDS

4.1. The Discharger must retain records of all monitoring information, including all calibration and maintenance records and all original strip chart recordings for continuous monitoring instrumentation, copies of all reports required by this Order, and records of all data used to complete the application for this Order, for a period of at least three (3) years from the date of the sample, measurement, report or application. This period may be extended by request of the Lahontan Water Board Executive Officer at any time. (40 C.F.R. § 122.41(j)(2))

4.2. Records of monitoring information must include:

- 4.2.1. The date, exact place, and time of sampling or measurements (40 C.F.R. § 122.41(j)(3)(i));
- 4.2.2. The individual(s) who performed the sampling or measurements (40 C.F.R. § 122.41(j)(3)(ii));
- 4.2.3. The date(s) analyses were performed (40 C.F.R. § 122.41(j)(3)(iii));
- 4.2.4. The individual(s) who performed the analyses (40 C.F.R. § 122.41(j)(3)(iv));
- 4.2.5. The analytical techniques or methods used (40 C.F.R. § 122.41(j)(3)(v)); and
- 4.2.6. The results of such analyses. (40 C.F.R. § 122.41(j)(3)(vi))

4.3. Claims of confidentiality for the following information will be denied (40 C.F.R. § 122.7(b)):

- 4.3.1. The name and address of any permit applicant or Discharger (40 C.F.R. § 122.7(b)(1)); and

- 4.3.2. Permit applications and attachments, permits and effluent data.
(40 C.F.R. § 122.7(b)(2))

5. STANDARD PROVISIONS – REPORTING

5.1. Duty to Provide Information

The Discharger must furnish to the Lahontan Water Board, State Water Board, or U.S. EPA within a reasonable time, any information which the Lahontan Water Board, State Water Board, or U.S. EPA may request to determine whether cause exists for modifying, revoking and reissuing, or terminating this Order or to determine compliance with this Order. Upon request, the Discharger must also furnish to the Lahontan Water Board, State Water Board, or U.S. EPA copies of records required to be kept by this Order.

(40 C.F.R. § 122.41(h); Wat. Code, §§ 13267, 13383.)

5.2. Signatory and Certification Requirements

- 5.2.1. All applications, reports, or information submitted to the Lahontan Water Board, State Water Board, and/or U.S. EPA must be signed and certified in accordance with Standard Provisions – Reporting 5.2.2, 5.2.3, 5.2.4, 5.2.5, and 5.2.6 below.
(40 C.F.R. § 122.41(k).)

- 5.2.2. All permit applications must be signed by a responsible corporate officer. For the purpose of this section, a responsible corporate officer means: (i) A president, secretary, treasurer, or vice-president of the corporation in charge of a principal business function, or any other person who performs similar policy- or decision-making functions for the corporation, or (ii) the manager of one or more manufacturing, production, or operating facilities, provided, the manager is authorized to make management decisions which govern the operation of the regulated facility including having the explicit or implicit duty of making major capital investment recommendations, and initiating and directing other comprehensive measures to assure long term environmental compliance with environmental laws and regulations; the manager can ensure that the necessary systems are established or actions taken to gather complete and accurate information for permit application requirements; and where authority to sign documents has been assigned or delegated to the manager in accordance with corporate procedures. (40 C.F.R. § 122.22(a)(1))

- 5.2.3. All reports required by this Order and other information requested by the Lahontan Water Board, State Water Board, or U.S. EPA must be signed by a person described in Standard Provisions – Reporting 5.2.2 above, or by a duly authorized representative of that person. A person is a duly authorized representative only if:

- 5.2.3.1. The authorization is made in writing by a person described in Standard Provisions – Reporting 5.2.2 above (40 C.F.R. § 122.22(b)(1));
- 5.2.3.2. The authorization specifies either an individual or a position having responsibility for the overall operation of the regulated facility or activity such as the position of plant manager, operator of a well or a well field, superintendent,

position of equivalent responsibility, or an individual or position having overall responsibility for environmental matters for the company. (A duly authorized representative may thus be either a named individual or any individual occupying a named position.) (40 C.F.R. § 122.22(b)(2)); and

- 5.2.3.3. The written authorization is submitted to the Lahontan Water Board and State Water Board. (40 C.F.R. § 122.22(b)(3))
- 5.2.4. If an authorization under Standard Provisions – Reporting 5.2.3 above is no longer accurate because a different individual or position has responsibility for the overall operation of the facility, a new authorization satisfying the requirements of Standard Provisions – Reporting 5.2.3 above must be submitted to the Lahontan Water Board and State Water Board prior to or together with any reports, information, or applications, to be signed by an authorized representative. (40 C.F.R. § 122.22(c))
- 5.2.5. Any person signing a document under Standard Provisions – Reporting 5.2.2 or 5.2.3 above must make the following certification:
“I certify under penalty of law that this document and all attachments were prepared under my direction or supervision in accordance with a system designed to assure that qualified personnel properly gather and evaluate the information submitted. Based on my inquiry of the person or persons who manage the system or those persons directly responsible for gathering the information, the information submitted is, to the best of my knowledge and belief, true, accurate, and complete. I am aware that there are significant penalties for submitting false information, including the possibility of fine and imprisonment for knowing violations.” (40 C.F.R. § 122.22(d))
- 5.2.6. Any person providing the electronic signature for documents described in Standard Provisions – 5.2.1, 5.2.2, or 5.2.3 that are submitted electronically must meet all relevant requirements of Standard Provisions – Reporting 5.2, and must ensure that all relevant requirements of 40 C.F.R. part 3 (Cross-Media Electronic Reporting) and 40 C.F.R. part 127 (NPDES Electronic Reporting Requirements) are met for that submission. (40 C.F.R. § 122.22(e))

5.3. Monitoring Reports

- 5.3.1. Monitoring results must be reported at the intervals specified in the Monitoring and Reporting Program (Attachment E) in this Order. (40 C.F.R. § 122.41(l)(4))
- 5.3.2. Monitoring results must be reported on a Discharge Monitoring Report (DMR) form or forms provided or specified by the Lahontan Water Board or State Water Board. As of December 21, 2016, all reports and forms must be submitted electronically to the initial recipient defined in Standard Provisions – Reporting 5.10 and comply with 40 C.F.R. part 3, 40 C.F.R. section 122.22, and 40 C.F.R. part 127. (40 C.F.R. § 122.41(l)(4)(i))
- 5.3.3. If the Discharger monitors any pollutant more frequently than required by this Order using test procedures approved under 40 C.F.R. part 136, or another method required for an industry-specific waste stream under 40 C.F.R. chapter 1, subchapter N, the results of such monitoring must be included in the calculation

and reporting of the data submitted in the DMR or reporting form specified by the Lahontan Water Board or State Water Board.

(40 C.F.R. § 122.41(l)(4)(ii))

- 5.3.4. Calculations for all limitations, which require averaging of measurements, must utilize an arithmetic mean unless otherwise specified in this Order.

(40 C.F.R. § 122.41(l)(4)(iii))

5.4. Compliance Schedules

Reports of compliance or noncompliance with, or any progress reports on, interim and final requirements contained in any compliance schedule of this Order, must be submitted no later than 14 days following each schedule date.

(40 C.F.R. § 122.41(l)(5))

5.5. Twenty-Four Hour Reporting

- 5.5.1. The Discharger must report any noncompliance which may endanger health or the environment. Any information must be provided orally within 24 hours from the time the Discharger becomes aware of the circumstances. A report must also be provided within five (5) days of the time the Discharger becomes aware of the circumstances. The report must contain a description of the noncompliance and its cause; the period of noncompliance, including exact dates and times, and if the noncompliance has not been corrected, the anticipated time it is expected to continue; and steps taken or planned to reduce, eliminate, and prevent reoccurrence of the noncompliance.

For noncompliance events related to combined sewer overflows, sanitary sewer overflows, or bypass events, these reports must include the data described above (with the exception of time of discovery) as well as the type of event (i.e., combined sewer overflow, sanitary sewer overflow, or bypass event), type of overflow structure (e.g., manhole, combined sewer overflow outfall), discharge volume untreated by the treatment works treating domestic sewage, types of human health and environmental impacts of the event, and whether the noncompliance was related to wet weather.

As of December 21, 2023, all reports related to combined sewer overflows, sanitary sewer overflows, or bypass events must be submitted to the Lahontan Water Board and must be submitted electronically to the initial recipient defined in Standard Provisions – Reporting 5.10 The reports must comply with 40 C.F.R. part 3, 40 C.F.R. section 122.22, and 40 C.F.R. part 127. The Lahontan Water Board may also require the Discharger to electronically submit reports not related to combined sewer overflows, sanitary sewer overflows, or bypass events under this section. (40 C.F.R. § 122.41(l)(6)(i))

- 5.5.2. The following must be included as information that must be reported within 24 hours:

- 5.5.2.1. Any unanticipated bypass that exceeds any effluent limitation in this Order.

(40 C.F.R. § 122.41(l)(6)(ii)(A))

5.5.2.2. Any upset that exceeds any effluent limitation in this Order.
(40 C.F.R. § 122.41(l)(6)(ii)(B))

5.5.3. The Lahontan Water Board may waive the above required written report on a case-by-case basis if an oral report has been received within 24 hours. (40 C.F.R. § 122.41(l)(6)(ii)(B))

5.6. Planned Changes

The Discharger must give notice to the Lahontan Water Board as soon as possible of any planned physical alterations or additions to the permitted facility. Notice is required under this provision only when (40 C.F.R. § 122.41(l)(1)):

5.6.1. The alteration or addition to a permitted facility may meet one of the criteria for determining whether a facility is a new source in section 122.29(b) (40 C.F.R. § 122.41(l)(1)(i)); or

5.6.2. The alteration or addition could significantly change the nature or increase the quantity of pollutants discharged. This notification applies to pollutants that are subject neither to effluent limitations in this Order nor to notification requirements under section 122.42(a)(1) (see Additional Provisions—Notification Levels 7.1.1). (40 C.F.R. § 122.41(l)(1)(ii))

5.7. Anticipated Noncompliance

The Discharger must give advance notice to the Lahontan Water Board of any planned changes in the permitted facility or activity that may result in noncompliance with this Order's requirements. (40 C.F.R. § 122.41(l)(2))

5.8. Other Noncompliance

The Discharger must report all instances of noncompliance not reported under Standard Provisions – Reporting 5.3, 5.4, and 5.5 above at the time monitoring reports are submitted. The reports must contain the information listed in Standard Provision – Reporting 5.5 above. For noncompliance events related to combined sewer overflows, sanitary sewer overflows, or bypass events, these reports must contain the information described in Standard Provision – Reporting 5.5 and the applicable required data in appendix A to 40 C.F.R. part 127. The Lahontan Water Board may also require the Discharger to electronically submit reports not related to combined sewer overflows, sanitary sewer overflows, or bypass events under this section. (40 C.F.R. § 122.41(l)(7))

5.9 Other Information

When the Discharger becomes aware that it failed to submit any relevant facts in a permit application, or submitted incorrect information in a permit application or in any report to the Lahontan Water Board, State Water Board, or U.S. EPA, the Discharger must promptly submit such facts or information. (40 C.F.R. § 122.41(l)(8))

5.10. Initial Recipient for Electronic Reporting Data

The owner, operator, or the duly authorized representative is required to electronically submit NPDES information specified in appendix A to

40 C.F.R. part 127 to the initial recipient defined in 40 C.F.R. section 127.2(b). U.S. EPA will identify and publish the list of initial recipients on its website and in the Federal Register, by state and by NPDES data group [see 40 C.F.R. section 127.2(c)]. U.S. EPA will update and maintain this listing. (40 C.F.R. § 122.41(l)(9))

6. STANDARD PROVISIONS – ENFORCEMENT

6.1. The Lahontan Water Board is authorized to enforce the terms of this permit under several provisions of the Water Code, including, but not limited to, sections 13268, 13385, 13386, and 13387.

7. ADDITIONAL PROVISIONS – NOTIFICATION LEVELS

7.1. Non-Municipal Facilities

Existing manufacturing, commercial, mining, and silvicultural Dischargers must notify the Lahontan Water Board as soon as they know or have reason to believe (40 C.F.R. § 122.42(a)):

7.1.1. That any activity has occurred or will occur that would result in the discharge, on a routine or frequent basis, of any toxic pollutant that is not limited in this Order, if that discharge will exceed the highest of the following "notification levels" (40 C.F.R. § 122.42(a)(1)):

7.1.1.1. 100 micrograms per liter ($\mu\text{g/L}$) (40 C.F.R. § 122.42(a)(1)(i));

7.1.1.2. 200 $\mu\text{g/L}$ for acrolein and acrylonitrile; 500 $\mu\text{g/L}$ for 2,4 dinitrophenol and 2-methyl 4,6 dinitrophenol; and 1 milligram per liter (mg/L) for antimony (40 C.F.R. § 122.42(a)(1)(ii));

7.1.1.3. Five (5) times the maximum concentration value reported for that pollutant in the Report of Waste Discharge (40 C.F.R. § 122.42(a)(1)(iii)); or

7.1.1.4. The level established by the Lahontan Water Board in accordance with section 122.44(f). (40 C.F.R. § 122.42(a)(1)(iv))

7.1.2. That any activity has occurred or will occur that would result in the discharge, on a non-routine or infrequent basis, of any toxic pollutant that is not limited in this Order, if that discharge will exceed the highest of the following "notification levels" (40 C.F.R. § 122.42(a)(2)):

7.1.2.1. 500 micrograms per liter ($\mu\text{g/L}$) (40 C.F.R. § 122.42(a)(2)(i));

7.1.2.2. 1 milligram per liter (mg/L) for antimony (40 C.F.R. § 122.42(a)(2)(ii));

7.1.2.3. Ten (10) times the maximum concentration value reported for that pollutant in the Report of Waste Discharge (40 C.F.R. § 122.42(a)(2)(iii)); or

7.1.2.4. The level established by the Lahontan Water Board in accordance with section 122.44(f). (40 C.F.R. § 122.42(a)(2)(iv))

ATTACHMENT E – MONITORING AND REPORTING PROGRAM

TABLE OF CONTENTS

1. GENERAL MONITORING PROVISIONS.....E-2
2. MONITORING LOCATIONSE-3
3. INFLUENT MONITORING REQUIREMENTS.....E-4
 3.1. Monitoring Location INF-001E-4
4. EFFLUENT MONITORING REQUIREMENTS.....E-5
 4.1. Monitoring Location EFF-001E-5
5. WHOLE EFFLUENT TOXICITY TESTING REQUIREMENTS – NOT APPLICABLE.E-6
6. LAND DISCHARGE MONITORING REQUIREMENTS – NOT APPLICABLEE-7
7. RECYCLING MONITORING REQUIREMENTS – NOT APPLICABLEE-7
8. RECEIVING WATER MONITORING REQUIREMENTS – NOT APPLICABLEE-7
9. OTHER MONITORING REQUIREMENTS – NOT APPLICABLEE-7
10. REPORTING REQUIREMENTSE-7
 10.1. General Monitoring and Reporting Requirements.....E-7
 10.2. Self-Monitoring Reports (SMRs)E-7
 10.3. Discharge Monitoring Reports (DMRs)E-9
 10.4. Other ReportsE-10
 10.5. Summary of ReportsE-10

TABLE OF TABLES

Table E-1. Monitoring Station Locations.....E-3
Table E-2. Influent MonitoringE-4
Table E-3. Effluent Monitoring.....E-5
Table E-4. Monitoring Periods and Reporting Schedule.....E-8
Table E-5. Summary of ReportsE-10

ATTACHMENT E – MONITORING AND REPORTING PROGRAM

Section 308 of the federal Clean Water Act (CWA) and sections 122.41(h), (j)-(l), 122.44(i), and 122.48 of title 40 of the Code of Federal Regulations (40 C.F.R.) require that all NPDES permits specify monitoring and reporting requirements. Water Code sections 13267 and 13383 also authorize the Lahontan Water Board to establish monitoring, inspection, entry, reporting, and recordkeeping requirements. This MRP establishes monitoring, reporting, and recordkeeping requirements that implement the federal and California laws and/or regulations.

1. GENERAL MONITORING PROVISIONS

- 1.1. Samples and measurements taken as required herein must be representative of the volume and nature of the monitored discharge. All samples must be taken at the monitoring locations specified below and, unless otherwise specified, before the monitored flow joins or is diluted by any other waste stream, body of water, or substance. Monitoring locations must not be changed without notification to and the approval from the Lahontan Water Board.
- 1.2. Effluent samples must be taken downstream of the last addition of wastes to the treatment or discharge works where a representative sample may be obtained prior to mixing with the receiving waters. Samples must be collected at such a point and in such a manner to ensure a representative sample of the discharge.
- 1.3. Appropriate flow measurement devices and methods consistent with accepted scientific practices must be selected and used to ensure accuracy and reliability for measuring discharge volumes. The flow measurement devices must be installed, calibrated, and maintained to ensure that the accuracy of the measurements is consistent with the accepted capability of that type of device. Devices selected must be capable of measuring flows with a maximum deviation of less than ± 10 percent from true discharge rates throughout the range of expected discharge volumes.
- 1.4. **Laboratory Certification:** Laboratories analyzing monitoring samples must be certified by the State Water Resources Control Board (State Water Board), in accordance with the provision of Water Code section 13176, and must include quality assurance/quality control data with their reports. In the event a certified laboratory is not available to the Discharger, analyses performed by a non-certified laboratory or using field test kits will be accepted provided that a Quality Assurance/Quality Control Program (QA/QC) is instituted by the laboratory and approved by the Executive Officer. Documentation of QA/QC protocols and adherence to the protocols must be kept in the laboratory or at the site for field test kits and must be available for inspection by Lahontan Water Board staff. The QA/QC Program must conform to U.S. EPA guidelines or to procedures approved by the Lahontan Water Board. Supplemental field testing for constituents that could be analyzed by a certified laboratory may be done in the field with test kits and meters provided:
 - 1.4.1. Samples collected at the minimum-required monitoring frequencies are performed by a certified lab,

- 1.4.2. A QA/QC program approved by the Executive Officer or Designee is followed,
- 1.4.3. Detection limits, accuracy, and precision of the kits and meters meet U.S. EPA and Surface Water Ambient Monitoring Program (SWAMP) standards, and
- 1.4.4. All results for field testing must be reported to the Lahontan Water Board in semi-annual self-monitoring reports (SMRs). Supporting QA/QC data must be determined using an established program and retained onsite and reported if requested.
- 1.5. All monitoring instruments and devices used by the Discharger to fulfill the prescribed monitoring program must be properly maintained and calibrated as necessary to ensure their continued accuracy. All flow measurement devices must be calibrated at least once per year to ensure continued accuracy of the devices.
- 1.6. Monitoring results, including noncompliance, must be reported at intervals and in a manner specified in this Monitoring and Reporting Program (MRP).
- 1.7. The results of all monitoring required by this Order must be reported to the Lahontan Water Board and must be submitted in such a format as to allow direct comparison with the limitations and requirements of this Order. Unless otherwise specified, discharge flows must be reported in terms of the monthly average and the daily maximum discharge flows.

2. MONITORING LOCATIONS

The Discharger must establish the following monitoring locations to demonstrate compliance with the effluent limitations, discharge specifications, and other requirements in this Order:

Table E-1. Monitoring Station Locations

Discharge Point Name	Monitoring Location Name	Monitoring Location Description
--	INF-001	At the wellhead prior to the heat exchange process.
001	EFF-001	A location where a representative sample of the effluent from the Facility can be collected, uninfluenced by any surfacing geothermal springs; from the discharge pipe into the receiving water and prior to mixing in the receiving water channel. Latitude: 40° 21' 24" N Longitude: -120° 15' 23" W

The North latitude and West longitude information in Table E-1 are approximate for administrative purposes.

3. INFLUENT MONITORING REQUIREMENTS

3.1. Monitoring Location INF-001

Table E-2. Influent Monitoring

Parameter	Units	Sample Type	Minimum Sampling Frequency	Required Analytical Test Method
Flow	MGD	Meter	Continuous	--
pH	Standard units	Grab	2/Year ¹	2
Arsenic, Total Recoverable	µg/L	Grab	2/Year ^{1,3}	2,4
Bis (2-Ethylhexyl) Phthalate	µg/L	Grab	2/Year ^{1,3}	2,4,5
Copper, Total Recoverable	µg/L	Grab	2/Year ^{1,3}	2,4
Lead, Total Recoverable	µg/L	Grab	2/Year ^{1,3}	2,4
Mercury, Total Recoverable	µg/L	Grab	2/Year ^{1,3}	2,4
Zinc, Total Recoverable	µg/L	Grab	2/Year ^{1,3}	2,4
Remaining Priority Pollutants ⁶	µg/L	Grab	3,7	2,4
Boron, Total Recoverable	µg/L	Grab	2/Year ¹	2
Hardness (as CaCO ₃)	mg/L	Grab	2/Year ^{1,3}	2
Molybdenum, Total Recoverable	µg/L	Grab	2/Year ¹	2
Benzene	µg/L	Grab	2/Year ¹	2
Toluene	µg/L	Grab	2/Year ¹	2
Temperature	°F/°C	Grab	2/Year ^{1,8}	2

Table E-2 Notes:

1. Pollutants must be sampled in May and November, concurrent with effluent samples.
2. Pollutants must be analyzed using the analytical methods described in 40 C.F.R. part 136.
3. Hardness must be sampled concurrently with priority pollutants.

4. For priority pollutant constituents the reporting level (RL) must be consistent with sections 2.4.2 and 2.4.3 of the *Policy for Implementation of Toxics Standards for Inland Surface Waters, Enclosed Bays, and Estuaries of California* (SIP). If more than one analytical test method is listed for a given pollutant, the Discharger must select the lowest minimum levels (MLs) specified in Appendix 4 of the SIP.
 5. In order to verify if bis (2-ethylhexyl) phthalate is truly present, the Discharger must take steps to assure that sample containers, sampling apparatus, and analytical equipment are not sources of the detected contaminant.
 6. A list of all 126 priority pollutants can be found in Appendix 4 of the SIP.
 7. Pollutants must be sampled in May and November during the fourth year following the adoption date of this Order.
 8. Temperature must be measured and recorded during any sample collection.
- 3.1.1. The Discharger must monitor geothermal fluid at the wellhead prior to the heat exchange process at Monitoring Location INF-001 as described above. If more than one analytical test method is listed for a given parameter, the Discharger must select from the listed methods and corresponding ML.

4. EFFLUENT MONITORING REQUIREMENTS

4.1. Monitoring Location EFF-001

Table E-3. Effluent Monitoring

Parameter	Units	Sample Type	Minimum Sampling Frequency	Required Analytical Test Method and (Minimum Level, units), respectively
Flow	MGD	Meter	Continuous	--
pH	Standard units	Grab	2/Year ¹	2
Arsenic, Total Recoverable	µg/L	Grab	2/Year ^{1,3}	2,4
Bis (2-Ethylhexyl) Phthalate	µg/L	Grab	2/Year ^{1,3}	2,4,5
Copper, Total Recoverable	µg/L	Grab	2/Year ^{1,3}	2,4
Lead, Total Recoverable	µg/L	Grab	2/Year ^{1,3}	2,4
Mercury, Total Recoverable	µg/L	Grab	2/Year ^{1,3}	2,4
Zinc, Total Recoverable	µg/L	Grab	2/Year ^{1,3}	2,4

Parameter	Units	Sample Type	Minimum Sampling Frequency	Required Analytical Test Method and (Minimum Level, units), respectively
Remaining Priority Pollutants ⁶	µg/L	Grab	3, 7	2,4
Boron, Total Recoverable	µg/L	Grab	2/Year ¹	2,4
Hardness (as CaCO ₃)	mg/L	Grab	2/Year ¹	2
Molybdenum, Total Recoverable	µg/L	Grab	2/Year ¹	2
Benzene	µg/L	Grab	2/Year ¹	2
Toluene	µg/L	Grab	2/Year ¹	2
Temperature	°F/°C	Grab	2/Year ^{1,8}	2

Table E-3 Notes:

1. Pollutants must be sampled in May and November, concurrent with influent samples.
 2. Pollutants must be analyzed using the analytical methods described in 40 C.F.R. part 136.
 3. Hardness must be sampled concurrently with priority pollutants.
 4. For priority pollutant constituents the RL must be consistent with sections 2.4.2 and 2.4.3 of the SIP. If more than one analytical test method is listed for a given pollutant, the Discharger must select the lowest MLs specified in Appendix 4 of the SIP.
 5. In order to verify if bis (2-ethylhexyl) phthalate is truly present, the Discharger must take steps to assure that sample containers, sampling apparatus, and analytical equipment are not sources of the detected contaminant.
 6. A list of all 126 priority pollutants can be found in Appendix 4 of the SIP.
 7. Pollutants must be sampled in May and November during the fourth year following the adoption date of this Order.
 8. Temperature must be measured and recorded during any sample collection.
- 4.1.1. The Discharger must monitor effluent from the Facility at Monitoring Location EFF-001 as described above. If more than one analytical test method is listed for a given parameter, the Discharger must select from the listed methods and corresponding ML.

5. WHOLE EFFLUENT TOXICITY TESTING REQUIREMENTS – NOT APPLICABLE

6. LAND DISCHARGE MONITORING REQUIREMENTS – NOT APPLICABLE

7. RECYCLING MONITORING REQUIREMENTS – NOT APPLICABLE

8. RECEIVING WATER MONITORING REQUIREMENTS – NOT APPLICABLE

9. OTHER MONITORING REQUIREMENTS – NOT APPLICABLE

10. REPORTING REQUIREMENTS

10.1. General Monitoring and Reporting Requirements

The Discharger must comply with all Standard Provisions (Attachment D) related to monitoring, reporting, and recordkeeping.

- 10.1.1. The Discharger must submit a summary annual monitoring report. The report must contain all data collected for the year in a table, and both tabular and graphical summaries of the monitoring data obtained during the previous year(s).
- 10.1.2. The Discharger must calculate and report the result of compliance with maximum daily effluent limitations, as necessary. Additional samples may be collected to demonstrate compliance.
- 10.1.3. The Discharger must report to the Lahontan Water Board any toxic chemical release data it reports to the State Emergency Response Commission within 15 days of reporting the data to the Commission pursuant to section 313 of the “Emergency Planning and Community Right to Know Act of 1986.”
- 10.1.4. For each parameter with an effluent limitation listed in this Order, the Discharger must determine and report compliance with respect to the effluent limitation. The Discharger must determine and report compliance with respect to each receiving water limitation specified in the Order. For parameters with no monitoring required, the Discharger must report “Not Determined.”
- 10.1.5. As part of the Report of Waste Discharge (ROWD) submitted in accordance with the cover page of this Order and Table E-5, below, the Discharger must provide all reported data in an Excel tabular format that can be used to evaluate compliance with interim and/or final effluent limitations and conduct a reasonable potential analysis. Electronic submittal of data is required to be uploaded into the State Water Board’s California Integrated Water Quality System (CIWQS) Program. If the State Water Board’s Permit Entry Tool does not allow data to be submitted, it must be provided separately.

10.2. Self-Monitoring Reports (SMRs)

- 10.2.1. The Discharger must electronically submit SMRs using the State Water Board’s [CIWQS Program website](http://www.waterboards.ca.gov/water_issues/programs/ciwqs) (http://www.waterboards.ca.gov/water_issues/programs/ciwqs). The CIWQS website will provide additional information for SMR submittal in the event there will be a planned service interruption for electronic submittal.

10.2.2. The Discharger must report in the SMR the results for all monitoring specified in this MRP under sections 3 through 9. The Discharger must submit semiannual SMRs including the results of all required monitoring using U.S. EPA-approved test methods or other test methods specified in this Order. SMRs are to include all new monitoring results obtained since the last SMR was submitted. If the Discharger monitors any pollutant more frequently than required by this Order, the results of this monitoring must be included in the calculations and reporting of the data submitted in the SMR.

10.2.3. Monitoring periods and reporting for all required monitoring must be completed according to the following schedule:

Table E-4. Monitoring Periods and Reporting Schedule

Sampling Frequency	Monitoring Period Begins On	Monitoring Period	SMR Due Date
Continuous	Permit effective date	All	Submit with semi-annual SMR
Semiannually	Permit effective date	1 January through 30 June 1 July through 31 December	1 August 1 February of following year

10.2.4. **Reporting Protocols.** The Discharger must report with each sample result the applicable RL and the current Method Detection Limit (MDL), as determined by the procedure in 40 C.F.R. part 136. The Discharger must report the results of analytical determinations for the presence of chemical constituents in a sample using the following reporting protocols:

10.2.4.1. Sample results greater than or equal to the RL must be reported as measured by the laboratory (i.e., the measured chemical concentration in the sample).

10.2.4.2. Sample results less than the RL, but greater than or equal to the laboratory’s MDL, must be reported as “Detected, but Not Quantified,” or DNQ. The estimated chemical concentration of the sample must also be reported. For the purposes of data collection, the laboratory must write the estimated chemical concentration next to DNQ. The laboratory may, if such information is available, include numerical estimates of the data quality for the reported result. Numerical estimates of data quality may be percent accuracy (\pm a percentage of the reported value), numerical ranges (low to high), or any other means considered appropriate by the laboratory.

10.2.4.3. Sample results less than the laboratory’s MDL must be reported as “Not Detected,” or ND.

10.2.4.4. Dischargers are to instruct laboratories to establish calibration standards so that the ML value (or its equivalent if there is differential treatment of samples relative to calibration standards) is the lowest calibration standard. At no time is the Discharger to use analytical data derived from extrapolation beyond the lowest point of the calibration curve.

- 10.2.5. **Compliance Determination.** Compliance with effluent limitations for priority pollutants must be determined using sample reporting protocols defined above and in Attachment A. For purposes of reporting and administrative enforcement by the Lahontan Water Board and State Water Board, the Discharger must be deemed out of compliance with effluent limitations if the concentration of the priority pollutant in the monitoring sample is greater than the effluent limitation and greater than or equal to the RL.
- 10.2.6. **Multiple Sample Data.** When determining compliance with a maximum daily effluent limitation for priority pollutants and more than one sample result is available, the Discharger must compute the arithmetic mean unless the data set contains one or more reported determinations of “Detected, but Not Quantified” (DNQ) or “Not Detected” (ND). In those cases, the Discharger must compute the median in place of the arithmetic mean in accordance with the following procedure:
- 10.2.6.1. The data set must be ranked from low to high, ranking the reported ND determinations lowest, DNQ determinations next, followed by quantified values (if any). The order of the individual ND or DNQ determinations is unimportant.
- 10.2.6.2. The median value of the data set must be determined. If the data set has an odd number of data points, then the median is the middle value. If the data set has an even number of data points, then the median is the average of the two values around the middle unless one or both of the points are ND or DNQ, in which case the median value must be the lower of the two data points where DNQ is lower than a value and ND is lower than DNQ.
- 10.2.7. The Discharger must submit SMRs in accordance with the following requirements:
- 10.2.7.1. The Discharger must arrange all reported data in a tabular format. The data must be summarized to clearly illustrate whether the facility is operating in compliance with interim and/or final effluent limitations. The Discharger is not required to duplicate the submittal of data that is entered in a tabular format within CIWQS. When electronic submittal of data is required and CIWQS does not provide for entry into a tabular format within the system, the Discharger must electronically submit the data in a tabular format as an attachment.
- 10.2.7.2. The Discharger must attach a cover letter to the SMR. The information contained in the cover letter must clearly identify violations of the waste discharge requirements; discuss corrective actions taken or planned; and the proposed time schedule for corrective actions. Identified violations must include a description of the requirement that was violated and a description of the violation.
- 10.3. Discharge Monitoring Reports (DMRs)**
- 10.4.1. DMRs are U.S. EPA reporting requirements. The Discharger must electronically certify and submit DMRs together with SMRs using Electronic Self-Monitoring Reports module eSMR 2.5 or any upgraded version. Electronic DMR submittal must be in addition to electronic SMR submittal. Information about electronic

DMR submittal is available at the [DMR website](http://www.waterboards.ca.gov/water_issues/programs/discharge_monitoring) at:
 (http://www.waterboards.ca.gov/water_issues/programs/discharge_monitoring).

10.4. Other Reports

10.4.1. The Discharger must report the results of any special studies and best management practices (BMPs) required by the Special Provisions in section 6.3 of the Order. The Discharger must submit reports with the first semiannual SMR scheduled to be submitted on or immediately following the report due date.

10.4.2. The Discharger must submit a copy of the BMP Plan, as required by Special Provision 6.3.3.1, to the Executive Officer within 120 days from the effective date of this Order.

10.4.4. Operation and Maintenance:

A summary of any operational problems and maintenance activities must be submitted to the Lahontan Water Board with each semiannual SMR. This summary must discuss:

10.4.4.1. Any modification to plant operations.

10.4.4.2. Any maintenance conducted on the plant.

10.4.4.3. Any problems occurring with plant operations.

10.4.4.4. The calibration of any flow measuring devices.

10.4.5. **Report of Waste Discharge (ROWD).** The Discharger must file a ROWD in accordance with title 23, California Code of Regulations, as application for re-issuance of waste discharge requirements no later than specified in Table 3 of the Order. The ROWD must include a delimited formatted file, such as Excel®, that contains all monitored data that include, for each value, constituent, measurement date, measured value, MDL/RDL, and measurement units, and analysis method (for the previous permit cycle). In addition, the ROWD will also include annual average flow at Monitoring Locations EFF-001. The data date range is from **November 9, 2022** through the month before the ROWD due date.

10.5. Summary of Reports

The following table summarizes all reports the Discharger is required to submit.

Table E-5. Summary of Reports

Report Name	Location of Requirement	Monitoring Period	Due Date
Semiannual Influent and Effluent Monitoring Report	MRP sections 3 and 4	1 January through 30 June 1 July through 31 December	1 August 1 February of following year
Intake Credit Summary Report	Order section 6.3.2	N/A	November 9, 2024

Report Name	Location of Requirement	Monitoring Period	Due Date
BMP Plan	Order section 6.3.3.1	N/A	March 10, 2023
Operation and Maintenance Summary	MRP section 10.4.4	1 January through 30 June 1 July through 31 December	Submit with semiannual SMR
Report of Waste Discharge (ROWD)	MRP section 10.4.5	N/A	180 days before expiration date

ATTACHMENT F – FACT SHEET

1. PERMIT INFORMATION..... F-3

2. FACILITY DESCRIPTION F-4

 2.1. Description of Wastewater and Biosolids Treatment and Controls F-5

 2.2. Discharge Points and Receiving Waters F-5

 2.3. Summary of Existing Requirements and SMR Data F-5

 2.4. Compliance Summary..... F-6

 2.5. Planned Changes – Not Applicable F-6

3. APPLICABLE PLANS, POLICIES, AND REGULATIONS F-6

 3.1. Legal Authorities F-6

 3.2. California Environmental Quality Act (CEQA) F-7

 3.3. State and Federal Laws, Regulations, Policies, and Plans F-7

 3.4. Impaired Water Bodies on the CWA section 303(d) List F-9

 3.5. Other Plans, Polices and Regulations – Not Applicable..... F-10

4. RATIONALE FOR EFFLUENT LIMITATIONS AND DISCHARGE SPECIFICATIONS F-10

 4.1. Discharge Prohibitions F-10

 4.2. Technology-Based Effluent Limitations F-11

 4.3. Water Quality-Based Effluent Limitations (WQBELs)..... F-12

 4.4. Final Effluent Limitation Considerations F-33

 4.5. Interim Effluent Limitations – Not Applicable..... F-35

 4.6. Land Discharge Specifications – Not Applicable..... F-35

 4.7. Recycling Specifications – Not Applicable F-35

5. RATIONALE FOR RECEIVING WATER LIMITATIONS F-35

 5.1. Surface Water F-35

 5.2. Groundwater F-35

6. RATIONALE FOR PROVISIONS F-35

 6.1. Standard Provisions F-35

 6.2. Special Provisions..... F-36

7. RATIONALE FOR MONITORING AND REPORTING REQUIREMENTS..... F-36

 7.1. Influent Monitoring F-37

 7.2. Effluent Monitoring F-37

 7.3. Whole Effluent Toxicity Testing Requirements – Not Applicable..... F-38

 7.4. Receiving Water Monitoring F-38

 7.5. Other Monitoring Requirements – Not Applicable..... F-38

8. PUBLIC PARTICIPATION..... F-38

 8.1. Notification of Interested Parties F-38

 8.2. Written Comments F-39

 8.3. Public Hearing..... F-39

 8.4. Reconsideration of Waste Discharge Requirements..... F-39

 8.5. Information and Copying F-40

 8.6. Register of Interested Persons..... F-40

 8.7. Additional Information F-40

TABLE OF TABLES

Table F-1. Facility Information..... F-3
Table F-2. Historic Effluent Limitations and Monitoring Data¹ F-6
Table F-3. Basin Plan Beneficial Uses F-8
Table F-4. Reasonable Potential Analysis Summary for Discharge Point 001 F-15
Table F-5. Comparison of Influent Pollutant Concentrations to Applicable Water Quality Objectives F-24
Table F-6 – Facility Intake Water Compared to Surfacing Wendel Hot Springs F-29
Table F-7. Final Effluent Limitations for Discharge Point 001..... F-32

ATTACHMENT F – FACT SHEET

As described in section II.B of this Order, the Lahontan Water Board incorporates this Fact Sheet as findings of the Lahontan Water Board supporting the issuance of this Order. This Fact Sheet includes the legal requirements and technical rationale that serve as the basis for the requirements of this Order.

This Order has been prepared under a standardized format to accommodate a broad range of discharge requirements for Dischargers in California. Only those sections or subsections of this Order that are specifically identified as “not applicable” have been determined not to apply to this Discharger. Sections or subsections of this Order not specifically identified as “not applicable” are fully applicable to this Discharger.

1. PERMIT INFORMATION

The following table summarizes administrative information related to the facility.

Table F-1. Facility Information

WDID	6A180045901
Discharger	Baseload Power Wendel, LLC
Name of Facility	Wendel Geothermal Power Plant
Facility Address	733-015 Antola Road Wendel, CA 96136 Lassen
Facility Contact, Title and Phone	Larry Bandt, Project Manager, (775) 233-3641
Authorized Person to Sign and Submit Reports	Alexander Helling, President, 46-73-772-4020
Mailing Address	Ingmar Bergmans Gata 2, 114 34 Stockholm, Sweden
Billing Address	SAME
Type of Facility	Geothermal Power Production (SIC Code 4961)
Major or Minor Facility	Minor
Threat to Water Quality	3
Complexity	C
Pretreatment Program	Not Applicable
Recycling Requirements	Not Applicable

Facility Permitted Flow	1.152 million gallons per day (MGD)
Facility Design Flow	1.152 MGD
Watershed	Susanville Hydrologic Unit
Receiving Water	Wendel Hot Springs
Receiving Water Type	Inland surface water

1.1. Baseload Power Wendel, LLC (hereinafter Discharger) is the owner and operator of Wendel Geothermal Power Plant (hereinafter Facility), a geothermal power production plant. Northern Cross Land and Cattle Co. owns the property at 733-015 Antola Road on which the Facility is located.

For the purposes of this Order, references to the “discharger” or “permittee” in applicable federal and state laws, regulations, plans, or policy are held to be equivalent to references to the Discharger herein.

1.2. The Facility discharges wastewater to a natural channel that historically drained Wendel Hot Springs, a water of the United States, within the Susanville Hydrologic Unit. The Facility was previously regulated by Order R6T-2015-0010 and National Pollutant Discharge Elimination System (NPDES) Permit No. CA0103063 adopted on March 11, 2015 and expired on April 30, 2020. Attachment B provides maps of the area around the Facility. Attachment C provides flow schematics of the Facility.

1.3. The Discharger filed a Report of Waste Discharge (ROWD) and submitted an application for issuance of its waste discharge requirements (WDRs) and NPDES permit on January 11, 2021. Supplemental information was requested on February 10, 2021 and March 30, 2021 and received on February 22, 2021, March 3, 2021, March 10, 2021, June 16, 2021, and August 18, 2021. The application was deemed complete on August 23, 2021. A site visit was conducted on May 19th, 2021, to observe operations and collect additional data to develop permit limitations and requirements for waste discharge.

1.4. Regulations at 40 C.F.R. section 122.46 limit the duration of NPDES permits to a fixed term not to exceed five years. However, pursuant to California Code of Regulations, title 23, section 2235.4, the terms and conditions of an expired permit are automatically continued pending reissuance of the permit if the Discharger complies with all federal NPDES requirements for continuation of expired permits.

2. FACILITY DESCRIPTION

The Facility is located in Lassen County, California, approximately 20 miles east of the City of Susanville. The Facility lies within Section 22, T30N, R15E, MDB&M near the Wendel Hot Springs in Honey Lake Valley, as shown in Attachment B.

The Facility was placed into operation in 1986 and is currently entered in a Power Purchase Agreement with Lassen Municipal Utility District for the sale of California certified renewable energy. The Facility pumps thermally heated groundwater from the

Wendel geothermal reservoir from a depth of approximately 1,500 feet below the ground surface. A maximum flow of 800 gallons per minute (gpm) of geothermal fluid is pumped from a single production well, Wineagle #1, to a 700-kilowatt Rankine-cycle power plant. Heat is extracted through a heat exchange process and no chemicals are added to the flow by the Discharger (e.g., for scale control or to prevent pipe fouling) other than chemicals that may be scavenged from internal Facility piping or machinery. The spent geothermal fluids discharge through Discharge Point 001 to a natural channel that historically drained the Wendel Hot Springs. After the operation of the Wineagle #1 production well, the Wendel Hot Springs ceased to surface and flow into the existing channel. The discharge temperature is approximately 71°C (160°F) or less. Attachment C provides a flow schematic of the production well at the Facility.

2.1. Description of Wastewater and Biosolids Treatment and Controls

The geothermal fluid discharged from the power plant through Discharge Point 001 is not treated prior to discharge.

2.2. Discharge Points and Receiving Waters

The Facility is located near the northern margin of Honey Lake. The Honey Lake Valley Basin is a portion of the Basin and Range Geomorphic Province and is situated between the granitic Sierra Nevada mountain range to the southwest and the basaltic (volcanic) Modoc Plateau to the north. Local faults in the vicinity of the Facility reportedly trend in a north-northwest direction. Honey Lake is a relatively shallow terminal remnant of Lake Lahontan, which formerly covered vast portions of the region. Near the Facility, the granitic basement rocks are overlain by volcanic rock and sedimentary deposits. The groundwaters of Honey Lake Valley are recharged by precipitation, snowmelt, and seepage from streams and irrigation. Geothermal waters are related to the fault system and are reportedly associated with a deep aquifer underlying a non-thermal aquifer.

On June 15, 2021, the Discharger conducted a test to calculate the artesian flow from the Wineagle #1 geothermal well for comparison to the Facility's pumping rate. The flow test determined that the Facility pumps thermally heated groundwater from the Wendel geothermal reservoir at a rate (800 gpm) well below the artesian flow of the Wineagle #1 geothermal well (1,402 gpm).

The discharge point for the effluent to the receiving water channel is located at latitude 40° 21' 24" N and longitude 120° 15' 23" W (Discharge Point 001), within the Susan River Hydrologic Area (Department of Water Resources Hydrologic Unit No. 637.20).

2.3. Summary of Existing Requirements and SMR Data

Effluent limitations contained in the existing Order for discharges from Discharge Point 001 (Monitoring Location EFF-001) and representative monitoring data are as follows. The Facility did not discharge during the term of the previous Order; therefore, Table F-2 includes effluent monitoring data collected by Regional Water Board staff in addition to data provided with the permit application.

Table F-2. Historic Effluent Limitations and Monitoring Data¹

Parameter	Units	Average Monthly	Average Weekly	Maximum Daily	Highest Average Monthly Discharge	Highest Average Weekly Discharge	Highest Daily Discharge
Flow	MGD	--	--	1.152	--	--	NA
Arsenic, Total Recoverable	µg/L	--	--	270	--	--	210
Boron, Total Recoverable	µg/L	--	--	5,900	--	--	5800
Copper, Total Recoverable	µg/L	--	--	19	--	--	7
Lead, Total Recoverable	µg/L	--	--	18	--	--	ND
Mercury, Total Recoverable	µg/L	--	--	0.77	--	--	1.2
Molybdenum, Total Recoverable	µg/L	--	--	73	--	--	62

Table F-2 Notes:

NA is Not Available

ND is Not Detected

1. Table F-2 includes monitoring data collected by the Discharger on November 18, 2020 and reported in the ROWD.

2.4. Compliance Summary

The Discharger was not subject to any enforcement actions during the term of Order R6T-2015-0010.

2.5. Planned Changes – Not Applicable

3. APPLICABLE PLANS, POLICIES, AND REGULATIONS

The requirements contained in this Order are based on the requirements and authorities described in this section.

3.1. Legal Authorities

This Order serves as WDRs pursuant to article 4, chapter 4, division 7 of the California Water Code (commencing with section 13260). This Order is also issued pursuant to section 402 of the federal Clean Water Act (CWA) and implementing regulations adopted by the U.S. EPA and chapter 5.5, division 7 of the Water Code

(commencing with section 13370). It shall serve as an NPDES permit authorizing the Discharger to discharge into waters of the United States at the discharge location described in Table 1 subject to the WDRs in this Order.

3.2. California Environmental Quality Act (CEQA)

Under Water Code section 13389, this action to adopt an NPDES permit is exempt from CEQA, (commencing with section 21100) of division 13 of the Public Resources Code. This action also involves the re-issuance of WDRs for an existing facility with a discharge to groundwater of the Honey Lake Valley Basin and, as such, is also exempt from CEQA as an existing facility for which no expansion of its existing use is being permitted pursuant to title 14, California Code of Regulations, section 15301.

3.3. State and Federal Laws, Regulations, Policies, and Plans

3.3.1. **Water Quality Control Plan.** The Lahontan Water Board adopted *The Water Quality Control Plan for the Lahontan Region* (hereinafter Basin Plan) on March 31, 1995 that designates beneficial uses, establishes water quality objectives, and contains implementation programs and policies to achieve those objectives for all waters addressed through the plan. Requirements in this Order implement the Basin Plan. In addition, the Basin Plan implements State Water Board Resolution 88-63, which established state policy that all waters, with certain exceptions, should be considered suitable or potentially suitable for municipal or domestic supply (MUN). However, the Basin Plan does not designate municipal uses for Wendel Hot Springs based on a Use Attainability Analysis and a U.S. EPA-approved Basin Plan amendment that removed this potential surface water use after consideration of Resolution 88-63 criteria and federal water quality standards regulations.

The Basin Plan also identifies beneficial uses of groundwater that are applicable to all groundwater in the Lahontan Region. Beneficial uses of specific groundwater basins in the Lahontan Region are designated in Table 2-2 of the Basin Plan. The Facility is located within the Honey Lake Valley Basin. Unless otherwise designated by the Lahontan Water Board, all groundwaters are considered suitable, or potentially suitable, for MUN.

Thus, the beneficial uses applicable to Wendel Hot Springs in the Susanville Hydrologic Unit and groundwater in the Honey Lake Valley Basin are as follows.

Table F-3. Basin Plan Beneficial Uses

Discharge Point	Receiving Water Name	Beneficial Use(s)
001	Wendel Hot Springs	Agricultural Supply (AGR); Groundwater Recharge (GWR); Freshwater Replenishment (FRSH); Hydropower Generation (POW); Water Contact Recreation (REC-1); Non-Contact Water Recreation (REC-2); Wildlife Habitat (WILD); and Water Quality Enhancement (WQE).
	Honey Lake Valley Basin	Agricultural Supply (AGR); Freshwater Replenishment (FRSH); Industrial Service Supply (IND); Municipal and Domestic Supply (MUN); Wildlife Habitat (WILD).

3.3.2. National Toxics Rule (NTR) and California Toxics Rule (CTR). U.S. EPA adopted the NTR on December 22, 1992, and later amended it on May 4, 1995 and November 9, 1999. About forty criteria in the NTR applied in California. On May 18, 2000, U.S. EPA adopted the CTR. The CTR promulgated new toxics criteria for California and, in addition, incorporated the previously adopted NTR criteria that were applicable in the state. The CTR was amended on February 13, 2001. These rules contain federal water quality criteria for priority pollutants.

3.3.3. State Implementation Policy. On March 2, 2000, the State Water Board adopted the *Policy for Implementation of Toxics Standards for Inland Surface Waters, Enclosed Bays, and Estuaries of California* (State Implementation Policy or SIP). The SIP became effective on April 28, 2000, with respect to the priority pollutant criteria promulgated for California by the U.S. EPA through the NTR and to the priority pollutant objectives established by the Lahontan Water Board in the Basin Plan. The SIP became effective on May 18, 2000, with respect to the priority pollutant criteria promulgated by the U.S. EPA through the CTR. The State Water Board adopted amendments to the SIP on February 24, 2005, that became effective on July 13, 2005. The SIP establishes implementation provisions for priority pollutant criteria and objectives and provisions for chronic toxicity control. Requirements of this Order implement the SIP.

3.3.4. Antidegradation Policy. Federal regulation 40 C.F.R. section 131.12 requires that the state water quality standards include an antidegradation policy consistent with the federal policy. The State Water Board established California's antidegradation policy in State Water Board Resolution 68-16 ("Statement of Policy with Respect to Maintaining High Quality of Waters in California").

Resolution 68-16 is deemed to incorporate the federal antidegradation policy where the federal policy applies under federal law. Resolution 68 16 requires that existing water quality be maintained unless degradation is justified based on specific findings. The Lahontan Water Board's Basin Plan implements, and incorporates by reference, both the State and federal antidegradation policies. The permitted discharge must be consistent with the antidegradation provision of 40 C.F.R. section 131.12 and State Water Board Resolution 68-16.

- 3.3.5. **Anti-Backsliding Requirements.** Sections 402(o) and 303(d)(4) of the CWA and federal regulations at 40 C.F.R. section 122.44(l) restrict backsliding in NPDES permits. These anti-backsliding provisions require that effluent limitations in a reissued permit must be as stringent as those in the previous permit, with some exceptions in which limitations may be relaxed.
- 3.3.6. **Endangered Species Act Requirements.** This Order does not authorize any act that results in the taking of a threatened or endangered species or any act that is now prohibited, or becomes prohibited in the future, under either the California Endangered Species Act (Fish and Game Code, §§ 2050 to 2097) or the Federal Endangered Species Act (16 U.S.C.A. §§ 1531 to 1544). This Order requires compliance with effluent limits, receiving water limits, and other requirements to protect the beneficial uses of waters of the state. The Discharger is responsible for meeting all requirements of the applicable Endangered Species Act.

3.4. Impaired Water Bodies on the CWA section 303(d) List

U.S. EPA approved the State's 2014 and 2016 CWA section 303(d) list of impaired water bodies on April 6, 2018, prepared pursuant to CWA section 303(d), which requires identification of specific water bodies where it is expected that water quality standards will not be met after implementation of technology-based effluent limitations on point sources. The Lahontan Water Board plans to adopt Total Maximum Daily Loads (TMDLs) for applicable pollutants in impaired water bodies on the 303(d) list where it has not done so already. TMDLs establish waste load allocations (WLAs) for point sources and load allocations for non-point sources and are established to achieve the water quality standards for the impaired water bodies.

Wendel Hot Springs is not listed as an impaired water body. However, Honey Lake which ultimately receive discharges from the Facility, is listed on the 2018 CWA section 303(d) list as impaired. Honey Lake is listed as impaired for arsenic and salinity/TDS/chlorides; the sources for both impairments are unknown.

The Honey Lake Area Wetlands is listed for metals and the source of impairment is unknown. TMDLs for both Honey Lake and the Honey Lake Area Wetlands impairments are planned for completion by 2031. There are two areas along Honey Lake that are wildlife management areas that support wetlands that are fed by freshwater inputs from the west of Honey Lake and do not receive water from Wendel Hot Springs, (Honey Lake Waterfowl Management Area and Honey Lake State Wildlife Area).

The Basin Plan identifies Honey Lake as a receiving water of Wendel Hot Springs. The Basin Plan does not identify Honey Lake Wetlands as a receiving water of Wendel Hot Springs. In addition, there are wetlands created by the geothermal waters that are not connected or considered part of the Honey Lake Area Wetlands, and are not receiving waters for Wendel Hot Springs.

3.5. Other Plans, Policies and Regulations – Not Applicable

4. RATIONALE FOR EFFLUENT LIMITATIONS AND DISCHARGE SPECIFICATIONS

The CWA requires point source dischargers to control the amount of conventional, non-conventional, and toxic pollutants that are discharged into the waters of the United States. The control of pollutants discharged is established through effluent limitations and other requirements in NPDES permits. There are two principal bases for effluent limitations in the Code of Federal Regulations:

40 C.F.R. section 122.44(a) requires that permits include applicable technology-based limitations and standards; and 40 C.F.R. section 122.44(d) requires that permits include water quality-based effluent limitations to attain and maintain applicable numeric and narrative water quality criteria to protect the beneficial uses of the receiving water.

4.1. Discharge Prohibitions

- 4.1.1. The discharge prohibitions established in this Order are from waste discharge prohibitions in the Basin Plan that apply to the entire Lahontan Region (section 4.1) or based on discharge prohibitions specified in the Water Code.
- 4.1.2. Consistent with the Region-wide prohibition established in section 4.1 of the Basin Plan, this Order prohibits the discharge of pesticides to surface or groundwaters. Exemptions may be granted by the Water Board provided that specific exemption criteria specified in section 4.1 of the Basin Plan are satisfied.
- 4.1.3. This maximum daily flow prohibition in section 3.1.8 of the Order is based on the design flow of the Facility. Order R6T-2015-0010 included flow as an effluent limit based on the Facility design flow. Flow is not a pollutant and therefore has been changed from an effluent limit to a discharge prohibition in this Order, which is an equivalent level of regulation. This Order is not less stringent because compliance with flow as a discharge prohibition will be calculated the same way as the previous Order.
- 4.1.4. This Order prohibits the discharge of petroleum-based oil lubricants. To prevent the addition of petroleum-based chemicals into the effluent from the Facility, the Discharger is required to use non-petroleum-based pump oil lubricants. The ROWD did not identify the use or discharge of petroleum-based products from the Facility. The Discharger's planned use of a lubricant during pump operation was identified by Lahontan Water Board staff during an inspection in May 2021. In the Notice of Complete ROWD letter issued to the Discharger in August 2021, the Lahontan Water Board requested the Discharger research and utilize a non-petroleum-based pump lubricant. On February 23, 2022, the Discharger supplied

information concluding that food grade machinery oil would be a suitable alternative.

4.2. Technology-Based Effluent Limitations

4.2.1. Scope and Authority

Section 301(b) of the CWA and implementing U.S. EPA permit regulations at 40 C.F.R. section 122.44 require that permits include conditions meeting applicable technology-based requirements at a minimum, and any more stringent effluent limitations necessary to meet applicable water quality standards. The discharge authorized by this Order must meet minimum federal technology-based requirements based on Best Professional Judgment (BPJ) in accordance with 40 C.F.R. section 125.3.

The CWA requires that technology-based effluent limitations be established based on several levels of controls:

- 4.2.1.1. Best practicable treatment control technology (BPT) represents the average of the best existing performance by well-operated facilities within an industrial category or subcategory. BPT standards apply to toxic, conventional, and non-conventional pollutants.
- 4.2.1.2. Best available technology economically achievable (BAT) represents the best existing performance of treatment technologies that are economically achievable within an industrial point source category. BAT standards apply to toxic and non-conventional pollutants.
- 4.2.1.3. Best conventional pollutant control technology (BCT) represents the control from existing industrial point sources of conventional pollutants including biochemical oxygen demand, total suspended solids, fecal coliform, pH, and oil and grease. The BCT standard is established after considering a two-part reasonableness test. The first test compares the relationship between the costs of attaining a reduction in effluent discharge and the resulting benefits. The second test examines the cost and level of reduction of pollutants from the discharge from publicly owned treatment works to the cost and level of reduction of such pollutants from a class or category of industrial sources. Effluent limitations must be reasonable under both tests.
- 4.2.1.4. New source performance standards (NSPS) represent the best available demonstrated control technology standards. The intent of NSPS guidelines is to set limitations that represent state-of-the-art treatment technology for new sources.

The CWA requires U.S. EPA to develop effluent limitations, guidelines and standards (ELGs) representing application of BPT, BAT, BCT, and NSPS. Section 402(a)(1) of the CWA and 40 C.F.R. section 125.3 authorize the use of BPJ to derive technology-based effluent limitations on a case-by-case basis where ELGs are not available for certain industrial categories and/or pollutants of

concern. Where BPJ is used, the Lahontan Water Board must consider specific factors outlined in 40 C.F.R. section 125.3.

4.2.2. Applicable Technology-Based Effluent Limitations

There are no ELGs applicable to discharges associated with geothermal power plants. Therefore technology-based effluent limitations will be established for Discharge Point 001 based on BPJ, as described further below.

4.2.1.2. Best Management Practices Plan. Due to the lack of national ELGs for discharges from the geothermal power plant and pursuant to 40 C.F.R. section 122.44(k), the Discharger is required to develop and implement a Best Management Practices (BMP) Plan. The BMP Plan, based on BPJ, will serve as the equivalent of technology-based effluent limitations, to carry out the purposes and intent of the CWA. The Discharger is specifically required to develop and implement a BMP Plan in accordance with the requirements specified in Attachment G. The purpose of the BMP Plan will be to prevent the introduction of chemicals or other substances into the Facility and prevent the addition of pollutants from other non-permitted process waters, spills, or other potential sources of pollutants at the Facility. The BMP Plan must include site-specific plans and procedures implemented and/or to be implemented to prevent pollutants from being discharged to Wendel Hot Springs.

4.3. Water Quality-Based Effluent Limitations (WQBELs)

4.3.1. Scope and Authority

CWA section 301(b) and 40 C.F.R. section 122.44(d) require that permits include limitations more stringent than applicable federal technology-based requirements where necessary to achieve applicable water quality standards.

Section 122.44(d)(1)(i) of 40 C.F.R. requires that permits include effluent limitations for all pollutants that are or may be discharged at levels that have the reasonable potential to cause or contribute to an exceedance of a water quality standard, including numeric and narrative objectives within a standard. Where reasonable potential has been established for a pollutant, but there is no numeric criterion or objective for the pollutant, water quality-based effluent limitations (WQBELs) must be established using: (1) U.S. EPA criteria guidance under CWA section 304(a), supplemented where necessary by other relevant information; (2) an indicator parameter for the pollutant of concern; or (3) a calculated numeric water quality criterion, such as a proposed state criterion or policy interpreting the state's narrative criterion, supplemented with other relevant information, as provided in section 122.44(d)(1)(vi).

The process for determining reasonable potential and calculating WQBELs when necessary is intended to protect the designated uses of the receiving water as specified in the Basin Plan and achieve applicable water quality objectives and criteria that are contained in other state plans and policies, or any applicable water quality criteria contained in the CTR and NTR.

4.3.2. Applicable Beneficial Uses and Water Quality Criteria and Objectives

The Basin Plan designates beneficial uses, establishes water quality objectives, and contains implementation programs and policies to achieve those objectives for all waters addressed through the plan. In addition, the Basin Plan implements State Water Board Resolution No. 88-63, which established state policy that all waters, with certain exceptions, should be considered suitable or potentially suitable for municipal or domestic supply.

The federal CWA section 101(a)(2), states: *“it is the national goal that wherever attainable, an interim goal of water quality which provides for the protection and propagation of fish, shellfish, and wildlife, and for recreation in and on the water be achieved by July 1, 1983.”* Federal Regulations, developed to implement the requirements of the CWA, create a rebuttable presumption that all waters be designated as fishable and swimmable. Federal Regulations, 40 C.F.R. sections 131.2 and 131.10, require that all waters of the State be regulated to protect the beneficial uses of public water supply, protection and propagation of fish, shellfish and wildlife, recreation in and on the water, agricultural, industrial and other purposes including navigation. 40 C.F.R. section 131.3(e) defines existing beneficial uses as those uses actually attained after November 28, 1975, whether or not they are included in the water quality standards. Federal regulation, 40 C.F.R. section 131.10 requires that uses be obtained by implementing effluent limitations, requires that all downstream uses be protected and states that in no case shall a state adopt waste transport or waste assimilation as a beneficial use for any waters of the United States.

4.3.2.1. **Receiving Water and Beneficial Uses.** The Facility discharges wastewater to the Wendel Hot Springs, a water of the United States. The beneficial uses applicable to the Wendel Hot Springs are presented in Table F-3.

4.3.2.2. **Water Quality Objectives.** The water quality objectives applicable to the receiving water for this discharge are from the Basin Plan; the CTR, established by U.S. EPA at 40 C.F.R. section 131.38; and the NTR, established by U.S. EPA at 40 C.F.R. section 131.36. Some pollutants have water quality objectives established by more than one of these sources.

4.3.2.2.1 **Basin Plan.** The Basin Plan specifies numeric and narrative water quality objectives for pollutants in order to protect beneficial uses. The narrative toxicity objective states, *“All waters shall be maintained free of toxic substances in concentrations that are toxic to, or that produce detrimental physiological responses in human, plant, animal, or aquatic life.”* The Chemical Constituents provisions in the Basin Plan also states, *“Water designated as AGR shall not contain concentrations of chemical constituents in amounts that adversely affect the water for beneficial uses (i.e., agricultural purposes).”* Effluent limitations and provisions contained in this Order are designed to implement these objectives, based on available information.

4.3.2.2.2 **CTR.** The CTR specifies numeric aquatic life criteria for 23 priority toxic pollutants and numeric human health criteria for 57 priority toxic pollutants. These criteria apply to all inland surface waters and enclosed bays and

estuaries. Human health criteria are further identified as for “water and organisms” or for “organisms only.”

4.3.2.2.3 **NTR.** The NTR establishes numeric aquatic life criteria for selenium and numeric human health criteria for 33 toxic organic pollutants.

4.3.3. **Determining the Need for WQBELs**

Assessing whether a pollutant has reasonable potential to exceed a water quality objective in the water body is the fundamental step in determining whether or not a WQBEL is required.

4.3.3.1. **Reasonable Potential Analysis Methodology**

According to SIP section 1.3, the RPA begins with identifying the observed maximum effluent concentration (MEC) for each pollutant based on effluent concentration data. There are three triggers in determining reasonable potential:

- 4.3.3.1.1. Trigger 1 is activated if the MEC is greater than or equal to the lowest applicable water quality objective ($MEC \geq$ water quality objective), which has been adjusted, if appropriate, for pH, hardness, and translator data. If the MEC is greater than or equal to the adjusted water quality objective, then that pollutant has reasonable potential, and a WQBEL is required.
- 4.3.3.1.2. Trigger 2 is activated if the observed maximum ambient background concentration (B) is greater than the adjusted water quality objective ($B >$ water quality objective) and the pollutant is detected in any of the effluent samples.
- 4.3.3.1.3. Trigger 3 is activated if a review of other information determines that a WQBEL is required to protect beneficial uses, even though both MEC and B are less than the water quality objective.

To maintain consistency in methodology for permitting discharges of various constituents, the Lahontan Water Board used the same procedures required by the SIP for CTR constituents to evaluate reasonable potential and, where necessary, develop WQBELs for non-CTR constituents. For constituents with no promulgated numeric water quality criteria or objectives, the Lahontan Water Board interpreted narrative objectives from the Basin Plan to establish the basis for reasonable potential and effluent limitation calculations.

4.3.3.2. **Data and Information Used for the RPA**

The following describes the data used to perform an RPA for discharges from Discharge Point 001.

- 4.3.3.2.1. **Effluent Data.** Effluent monitoring data reported in the Discharger’s ROWD, one additional sample collected on November 18, 2020, and the nature of the discharge from Discharge Point 001 were analyzed to determine if the discharge has reasonable potential.
- 4.3.3.2.2. **Hardness.** Some freshwater metal objectives are hardness dependent. The lower the hardness, the more stringent the resulting criterion is. Effluent

hardness data was not collected by the Discharger during the term of Order R6T-2015-0010; therefore, hardness data collected during the term of previous Order R6T-2009-0006 was used to determine water quality objectives for hardness-dependent metals for this Order. Effluent hardness data collected during the term of previous Order R6T-2009-0006 ranged from 39.9 mg/L (as CaCO₃) to 47.4 mg/L (as CaCO₃). The low end of the range was conservatively used to determine the objectives for this Order.

4.3.3.2.3. **Ambient Background Data.** The ambient receiving waters for the discharges are remnants of the former Wendel Hot Springs, and associated wetlands and channels on the margins of, or terminating at, Honey Lake. No upstream (i.e., ambient background) receiving water data has been collected.

Order R6T-2015-0010 required monitoring of the influent, which is considered representative of the natural geothermal fluid prior to heat exchange within the Facility. Consistent with Order R6T-2015-0010, influent data was used to represent ambient background data for the purposes of determining whether a reasonable potential exists based on Trigger 2.

4.3.3.2.4. **Assimilative Capacity/Mixing Zone.** The Discharger has not provided an approved dilution/mixing zone study that meets the requirements in section 1.4.2.2 of the SIP; therefore, the worst-case dilution is assumed to be zero to provide protection of the receiving water beneficial uses. The impact of assuming zero assimilative capacity within the receiving water is that effluent limitations are applied end-of-pipe, with no allowance for dilution within the receiving water.

4.3.3.3. **Reasonable Potential Analysis.** The MECs and the most stringent applicable water quality objectives used in the RPA are presented in the following table, along with the RPA results for each pollutant. Reasonable potential was not determined for all pollutants because there are no water quality objectives for all pollutants, and monitoring data are unavailable for others. Based on a review of the influent and effluent data collected, the pollutants that exhibit reasonable potential by Trigger 1 are arsenic, bis (2-ethylhexyl) phthalate, boron, copper, mercury, and molybdenum.

Table F-4. Reasonable Potential Analysis Summary for Discharge Point 001

CTR #	Priority Pollutants	Governing Water Quality Objective (µg/L)	MEC or Minimum DL (µg/L)	Maximum Background or Minimum DL (µg/L) ^{1,2}	RPA Results ³
1	Antimony	4,300	<5	4	No Limit
2	Arsenic	150	210	210	Limit Required
3	Beryllium	No Criteria	<5	2	Undetermined
4	Cadmium	1.2	<5	Not Available	No Limit
5a	Chromium (III)	98	<5	2	No Limit

CTR #	Priority Pollutants	Governing Water Quality Objective (µg/L)	MEC or Minimum DL (µg/L)	Maximum Background or Minimum DL (µg/L) ^{1,2}	RPA Results ³
5b	Chromium (VI)	11	Not Available	0.2	No Limit
6	Copper	4.3	7	280 (DNQ)	Limit Required
7	Lead	0.99	<5	24 (DNQ)	No Limit, see section 4.3.3.3.2 below
8	Mercury	0.012	1.2	39	Limit Required
9	Nickel	24	5	Not Available	No Limit
10	Selenium	5	<25	Not Available	No Limit
11	Silver	0.84	<5	Not Available	No Limit
12	Thallium	6.3	<2.5	Not Available	No Limit
13	Zinc	55	<50	Not Available	No Limit
14	Cyanide	5.2	<0.005	Not Available	No Limit
15	Asbestos	No Criteria	<0.9	Not Available	Undetermined
16	2,3,7,8 TCDD	0.0000000 14	<0.00000 0368	Not Available	No Limit
17	Acrolein	780	<1	<1.9	No Limit
18	Acrylonitrile	0.66	<2.4	<4	No Limit
19	Benzene	71	8.5	0.15 (DNQ)	No Limit
20	Bromoform	360	<0.67	<0.25	No Limit
21	Carbon Tetrachloride	4.4	<0.05	<0.088	No Limit
22	Chlorobenzene	21,000	<0.05	<0.13	No Limit
23	Chlorodibromomethane	34	<0.05	<0.088	No Limit
24	Chloroethane	No Criteria	<0.057	<0.12	Undetermined
25	2-Chloroethylvinyl ether	No Criteria	<0.2	Not Available	Undetermined
26	Chloroform	No Criteria	<0.05	<0.098	Undetermined
27	Dichlorobromomethane	46	<0.05	<0.49	No Limit
28	1,1-Dichloroethane	No Criteria	<0.051	<0.086	Undetermined
29	1,2-Dichloroethane	99	<0.068	<0.11	No Limit
30	1,1-Dichloroethylene	3.2	<0.05	<0.14	No Limit
31	1,2-Dichloropropane	39	<0.05	<0.14	No Limit

CTR #	Priority Pollutants	Governing Water Quality Objective (µg/L)	MEC or Minimum DL (µg/L)	Maximum Background or Minimum DL (µg/L) ^{1,2}	RPA Results ³
32	1,3-Dichloropropylene	1,700	<0.05	Not Available	No Limit
33	Ethylbenzene	29,000	0.32 (DNQ)	<0.077	No Limit
34	Methyl Bromide	4,000	<0.077	<0.18	No Limit
35	Methyl Chloride	No Criteria	<0.055	<0.12	Undetermined
36	Methylene Chloride	1,600	<0.055	<0.14	No Limit
37	1,1,2,2-Tetrachloroethane	11	<0.066	<0.092	No Limit
38	Tetrachloroethylene	8.9	<0.05	<0.11	No Limit
39	Toluene	200,000	3.1	<0.11	No Limit
40	1,2-Trans-Dichloroethylene	140,000	<0.056	<0.12	No Limit
41	1,1,1-Trichloroethane	No Criteria	<0.05	<0.083	Undetermined
42	1,1,2-Trichloroethane	42	<0.05	<0.1	No Limit
43	Trichloroethylene	81	<0.081	<0.1	No Limit
44	Vinyl Chloride	525	<0.059	<0.1	No Limit
45	2-Chlorophenol	400	<0.2	Not Available	No Limit
46	2,4-Dichlorophenol	790	<0.23	Not Available	No Limit
47	2,4-Dimethylphenol	2,300	<0.2	Not Available	No Limit
48	2-methyl-4,6-Dinitrophenol	765	<0.24	Not Available	No Limit
49	2,4-Dinitrophenol	14,000	<0.2	Not Available	No Limit
50	2-Nitrophenol	No Criteria	<0.2	Not Available	Undetermined
51	4-Nitrophenol	No Criteria	<0.3	Not Available	Undetermined
52	3-Methyl-4-Chlorophenol	No Criteria	<0.2	Not Available	Undetermined
53	Pentachlorophenol	8.2	<0.4	Not Available	No Limit
54	Phenol	4,600,000	3.3	Not Available	No Limit
55	2,4,6-Trichlorophenol	6.5	<0.2	Not Available	No Limit
56	Acenaphthene	2,700	<0.2	Not Available	No Limit

CTR #	Priority Pollutants	Governing Water Quality Objective (µg/L)	MEC or Minimum DL (µg/L)	Maximum Background or Minimum DL (µg/L) ^{1,2}	RPA Results ³
57	Acenaphthylene	No Criteria	<0.2	Not Available	Undetermined
58	Anthracene	110,000	<0.2	Not Available	No Limit
59	Benzidine	0.00054	<1.6	Not Available	No Limit
60	Benzo(a)Anthracene	0.049	<0.21	Not Available	No Limit
61	Benzo(a)Pyrene	0.049	<0.2	Not Available	No Limit
62	Benzo(b)Fluoranthene	0.049	<0.24	Not Available	No Limit
63	Benzo(ghi)Perylene	No Criteria	<0.33	Not Available	Undetermined
64	Benzo(k)Fluoranthene	0.049	<0.3	Not Available	No Limit
65	Bis(2-Chloroethoxy)Methane	No Criteria	<0.2	Not Available	Undetermined
66	Bis(2-Chloroethyl)Ether	1.4	<0.31	Not Available	No Limit
67	Bis(2-Chloroisopropyl)Ether	170,000	<0.2	Not Available	No Limit
68	Bis(2-Ethylhexyl)Phthalate	5.9	30	Not Available	No Limit ⁴
69	4-Bromophenyl Phenyl Ether	No Criteria	<0.2	Not Available	Undetermined
70	Butylbenzyl Phthalate	5,200	<0.2	Not Available	No Limit
71	2-Chloronaphthalene	4,300	<0.2	Not Available	No Limit
72	4-Chlorophenyl Phenyl Ether	No Criteria	<0.2	Not Available	Undetermined
73	Chrysene	0.049	<0.2	Not Available	No Limit
74	Dibenzo(a,h)Anthracene	0.049	<0.34	Not Available	No Limit
75	1,2-Dichlorobenzene	17,000	<0.05	<0.11	No Limit
76	1,3-Dichlorobenzene	2,600	<0.05	<0.11	No Limit
77	1,4-Dichlorobenzene	2,600	<0.05	<0.15	No Limit
78	3,3 Dichlorobenzidine	0.080	<0.53	Not Available	No Limit

CTR #	Priority Pollutants	Governing Water Quality Objective (µg/L)	MEC or Minimum DL (µg/L)	Maximum Background or Minimum DL (µg/L) ^{1,2}	RPA Results ³
79	Diethyl Phthalate	120,000	<0.2	Not Available	No Limit
80	Dimethyl Phthalate	2,900,000	<0.2	Not Available	No Limit
81	Di-n-Butyl Phthalate	12,000	<0.2	Not Available	No Limit
82	2,4-Dinitrotoluene	9.1	<0.4	Not Available	No Limit
83	2,6-Dinitrotoluene	No Criteria	<0.2	Not Available	Undetermined
84	Di-n-Octyl Phthalate	No Criteria	<0.21	Not Available	Undetermined
85	1,2-Diphenylhydrazine	0.54	<0.2	Not Available	No Limit
86	Fluoranthene	370	<0.28	Not Available	No Limit
87	Fluorene	14,000	<0.2	Not Available	No Limit
88	Hexachlorobenzene	0.00077	<0.25	Not Available	No Limit
89	Hexachlorobutadiene	50	<0.2	<0.36	No Limit
90	Hexachlorocyclopentadiene	17,000	<0.31	Not Available	No Limit
91	Hexachloroethane	8.9	<0.2	Not Available	No Limit
92	Indeno(1,2,3-cd)Pyrene	0.049	<0.29	Not Available	No Limit
93	Isophorone	600	<0.2	Not Available	No Limit
94	Naphthalene	No Criteria	<0.2	<0.32	Undetermined
95	Nitrobenzene	1,900	<0.2	Not Available	No Limit
96	N-Nitrosodimethylamine	8.1	<1.2	Not Available	No Limit
97	N-Nitrosodi-n-Propylamine	1.4	<0.21	Not Available	No Limit
98	N-Nitrosodiphenylamine	16	<0.2	Not Available	No Limit
99	Phenanthrene	No Criteria	<0.2	Not Available	Undetermined

CTR #	Priority Pollutants	Governing Water Quality Objective (µg/L)	MEC or Minimum DL (µg/L)	Maximum Background or Minimum DL (µg/L) ^{1,2}	RPA Results ³
100	Pyrene	11,000	<0.22	Not Available	No Limit
101	1,2,4-Trichlorobenzene	No Criteria	<0.2	<0.29	Undetermined
102	Aldrin	0.00014	<0.0011	Not Available	No Limit
103	alpha-BHC	0.013	<0.0016	Not Available	No Limit
104	beta-BHC	0.046	<0.0018	Not Available	No Limit
105	gamma-BHC	0.063	<0.0015	Not Available	No Limit
106	delta-BHC	No Criteria	<0.0014	Not Available	Undetermined
107	Chlordane	0.00059	<0.068	Not Available	No Limit
108	4,4'-DDT	0.00059	<0.00082	Not Available	No Limit
109	4,4'-DDE	0.00059	<0.00081	Not Available	No Limit
110	4,4'-DDD	0.00084	<0.0012	Not Available	No Limit
111	Dieldrin	0.00014	<0.00078	Not Available	No Limit
112	alpha-Endosulfan	0.056	<0.00081	Not Available	No Limit
113	beta-Endosulfan	0.056	<0.0014	Not Available	No Limit
114	Endosulfan Sulfate	240	<0.001	Not Available	No Limit
115	Endrin	0.036	<0.00093	Not Available	No Limit
116	Endrin Aldehyde	0.81	<0.001	Not Available	No Limit
117	Heptachlor	0.00021	<0.00095	Not Available	No Limit
118	Heptachlor Epoxide	0.00011	<0.0016	Not Available	No Limit
119-125	PCBs ⁵	0.00017	<0.11	Not Available	No Limit
126	Toxaphene	0.00020	<0.57	Not Available	No Limit

CTR #	Priority Pollutants	Governing Water Quality Objective (µg/L)	MEC or Minimum DL (µg/L)	Maximum Background or Minimum DL (µg/L) ^{1,2}	RPA Results ³
	Ammonia, as N (mg/L)	0.37	0.2	Not Available	No Limit
	Boron	700	5,800	5,700 (DNQ)	Limit Required
	Molybdenum	10	62	68 (DNQ)	Limit Required

Table F-4 Notes:

1. The MEC and maximum background concentration are the actual detected concentrations unless preceded by a “<” sign, in which case the value shown is the minimum detection level (DL).
 2. The MEC or maximum background concentration is “Not Available” when there are no influent monitoring data for the constituent.
 3. RPA Results
 = Limit Required, if MEC > WQO, B > WQO and MEC is detected, or Trigger 3;
 = No Limit, if MEC and B are < WQO or all effluent data are undetected; or
 = Undetermined (Ud), if no criteria have been promulgated or there are insufficient data.
 4. See section 4.3.3.3.1, below, for a discussion of the RPA results for bis (2-ethylhexyl) phthalate.
 5. Total PCBs includes the sum of the following congeners: PCB-1016, PCB-1221, PCB-1232, PCB-1242, PCB1248, PCB-1254, and PCB-1260.
- 4.3.3.3.1. **Bis (2-Ethylhexyl) Phthalate.** Although reasonable potential for bis (2-ethylhexyl) phthalate was indicated by Trigger 1 (the MEC is greater than the applicable water quality objective), effluent limitations are not being established at this time. Bis (2-ethylhexyl) phthalate is commonly used as a plasticizer and, therefore, needs to be sampled with glass containers to avoid false positive results. Neither the Discharger’s ROWD nor the lab reports for the November 18, 2020 sampling event indicated whether steps were taken to assure that sample containers, sampling apparatus, and analytical equipment were not sources of the detected contaminant. Furthermore, no influent data for bis (2-ethylhexyl) phthalate was available for comparison to the November 18, 2020 sample. Section 1.3, step 8 of the SIP allows the Lahontan Water Board to require additional monitoring for a pollutant in place of an effluent limitation if data are unavailable or insufficient. Instead of effluent limitations, influent and effluent monitoring for bis (2 ethylhexyl) phthalate will be required semiannually. Furthermore, this Order requires the Discharger to take steps to assure that sample containers, sampling apparatus, and analytical equipment are not sources of the detected

contaminant. Should monitoring results indicate that the discharge has the reasonable potential to cause or contribute to an exceedance of a water quality standard, this Order may be reopened and modified by adding an appropriate effluent limitation.

- 4.3.3.3.2. **Lead.** Although influent and effluent data collected since the issuance of Order R6T-2015-0010 indicate that no reasonable potential exists for lead, this Order retains effluent limitations for total recoverable lead. The maximum observed influent concentration for lead was 24 µg/L based on a May 19, 2021 sample collected by the Lahontan Water Board. Based on ten influent samples collected prior to the adoption of Order R6T-2015-0010, the maximum observed influent concentration for lead was 5.8 µg/L. According to the laboratory reports corresponding to the May 19, 2021 influent lead sample, the influent lead result of 24 µg/L is an estimated value and due to the sample matrix, the reporting level was raised.

The single effluent lead sample collected on November 18, 2020 was non-detect; however, the reporting level (RL) was 5 µg/L, which is greater than the governing water quality objective of 0.99 µg/L. As described in section 3.2 of Attachment D to this Order (Standard Provisions), monitoring must be conducted according to sufficiently sensitive test methods approved under 40 C.F.R. part 136 for the analysis of pollutants or pollutant parameters. A method is sufficiently sensitive when the method minimum level (ML) is at or below the level of the most stringent effluent limitation established in the permit for the measured pollutant, and either the method ML is at or below the level of the most stringent applicable water quality criterion for the measured pollutant or the method ML is above the applicable water quality criterion but the amount of the pollutant in the Facility's discharge is high enough that the method detects and quantifies the level of the pollutant in the discharge. The RL for the November 18, 2020 effluent lead sample was greater than the governing water quality objective and the result was non-detect; therefore, the November 18, 2020 effluent monitoring event for lead was not conducted according to sufficiently sensitive test methods approved under 40 C.F.R. part 136.

Section 1.2 of the SIP states, "*The RWQCB shall have discretion to consider if any data are inappropriate or insufficient for use in implementing this Policy.*" The May 19, 2021 influent sample result for lead is an estimated value and appears to be an outlier compared to the remainder of the influent data collected since 2009. Additionally, the November 18, 2020 effluent monitoring event for lead was not conducted according to sufficiently sensitive test methods approved under 40 C.F.R. part 136. Therefore, the Lahontan Water Board concludes that the influent and effluent lead samples collected on May 19, 2021 and November 18, 2020, respectively, are insufficient for use in the RPA and effluent limitations for lead have been retained in this Order.

4.3.4. **WQBEL Calculations**

4.3.4.1. **Pollutants That Did Not Demonstrate Reasonable Potential**

WQBELs are not included in this Order for constituents that do not demonstrate reasonable potential or where it was undetermined whether WQBELs were necessary (e.g., where the reported detection levels are higher than the applicable criteria/objectives). However, monitoring during the term of this Order for those pollutants is required in accordance with section 1.3 of the SIP. If concentrations of these constituents are found to have increased significantly, the Discharger will be required to investigate the sources of the increases. Remedial measures are required if the increases pose a threat to receiving water quality.

For those constituents where the reported laboratory detection levels were higher than the applicable criteria/objectives, the analysis was not conducted according to the sufficiently sensitive methods rule. Section 3.2 of Attachment D to this Order (Standard Provisions), requires that monitoring must be conducted according to sufficiently sensitive test methods approved under 40 C.F.R. part 136 for the analysis of pollutants or pollutant parameters. A method is sufficiently sensitive when the method minimum level (ML), is at or below the level of the most stringent effluent limitation established in the permit for the measured pollutant, and either the method ML is at or below the level of the most stringent applicable water quality criterion for the measured pollutant or the method ML is above the applicable water quality criterion but the amount of the pollutant in the Facility's discharge is high enough that the method detects and quantifies the level of the pollutant in the discharge. The Discharger is responsible for ensuring that the reported results are conducted in a manner that complies with the sufficiently sensitive methods.

4.3.4.2. **Pollutants with Reasonable Potential**

This Order includes WQBELs for arsenic, boron, copper, lead, mercury, and molybdenum for discharges from Discharge Point 001. WQBELs for these parameters were calculated based on the allowance on intake credits, as described below.

4.3.4.2.1. **SIP Intake Water Credit Requirements.** SIP section 1.4.4 provides for intake water credits under specific circumstances. When met, a discharger may discharge a mass or concentration of a pollutant that is no greater than the mass or concentration found in its intake water (e.g., the discharger may add a mass of the pollutant to its waste stream if it also removes an equal or greater mass prior to discharge, resulting in no net addition of the pollutant). This Order provides intake water credits for arsenic, boron, copper, lead, mercury, and molybdenum discharges from Discharge Point 001, which comply with the SIP requirements.

In accordance with section 1.4.4 of the SIP, the Lahontan Water Board may consider pollutants in intake water on a pollutant-by-pollutant and discharge by-discharge basis when establishing WQBELs provided that the Discharger has demonstrated to the satisfaction of the Lahontan Water Board that five

specified conditions are met. A previous discharger submitted a May 2005 report, *A Review of Arsenic Levels in Intake and Discharge Waters at the Wineagle Power Plant, Lassen County, California* (GeothermEx, Inc.), addressing the SIP conditions. Upon review of this report, the Lahontan Water Board concurred that the SIP conditions were met for intake credits for arsenic, as well as the non-CTR constituents boron and molybdenum. Previous Order R6T-2009-0006 required a previous discharger to develop and submit an Intake Water Credit Summary Report to characterize the quality of the intake water and wastewater discharge. The previous discharger submitted a January 2011 report, *Wendel Energy Operations 1, LLC "Wineagle" Intake Water Credit Summary Report* (Oski Energy, LLC), which evaluated intake and effluent water quality from four monitoring events between 2009 and 2010. After review of these reports and available data, the Lahontan Water Board concurs that the discharge meets the conditions, as outlined in the SIP, for intake credits for arsenic, boron, copper, lead, mercury, and molybdenum discharges from Discharge Point 001; specifically:

Condition 1. The observed maximum ambient background concentration, as determined in section 1.4.3.1 of the SIP, and the intake water concentration of the pollutant exceeds the most stringent applicable criterion/objective for that pollutant.

Table F-5 represents influent and effluent data collected at the Facility since Order R6T-2009-0006 was issued.

Table F-5. Comparison of Influent Pollutant Concentrations to Applicable Water Quality Objectives

Parameter	Sample Date	Reported Influent Concentration (µg/L)	Reported Effluent Concentration (µg/L)	Most Stringent Objective (µg/L)
Arsenic, Total Recoverable	5/21/2009	170	162	150
Arsenic, Total Recoverable	11/18/2009	199	177	150
Arsenic, Total Recoverable	6/3/2010	214	159	150
Arsenic, Total Recoverable	11/3/2010	200	180	150
Arsenic, Total Recoverable	5/9/2011	187	156	150
Arsenic, Total Recoverable	11/10/2011	157	170	150
Arsenic, Total Recoverable	5/9/2012	290	202	150
Arsenic, Total Recoverable	11/28/2012	249	144	150

Parameter	Sample Date	Reported Influent Concentration (µg/L)	Reported Effluent Concentration (µg/L)	Most Stringent Objective (µg/L)
Arsenic, Total Recoverable	5/1/2013	191	171	150
Arsenic, Total Recoverable	11/6/2013	160	154	150
Arsenic, Total Recoverable	5/1/2015	--	163	150
Arsenic, Total Recoverable	11/18/2020	--	210	150
Arsenic, Total Recoverable	5/19/2021	210	--	150
Boron, Total Recoverable	5/21/2009	5,400	4,900	750
Boron, Total Recoverable	11/18/2009	5,100	4,200	750
Boron, Total Recoverable	6/3/2010	5,600	4,200	750
Boron, Total Recoverable	11/3/2010	5,040	4,540	750
Boron, Total Recoverable	5/9/2011	4,400	3,900	750
Boron, Total Recoverable	11/10/2011	5,000	4,600	750
Boron, Total Recoverable	5/9/2012	4,900	4,400	750
Boron, Total Recoverable	11/28/2012	5,000	4,300	750
Boron, Total Recoverable	5/1/2013	4,800	4,200	750
Boron, Total Recoverable	11/6/2013	5,100	4,000	750
Boron, Total Recoverable	11/18/2020	--	5,800	750
Boron, Total Recoverable	5/19/2021	5,700 (DNQ)	--	750
Copper, Total Recoverable	5/21/2009	1	1	4.3
Copper, Total Recoverable	11/18/2009	2	1	4.3
Copper, Total Recoverable	6/3/2010	4	2	4.3
Copper, Total Recoverable	11/3/2010	<10	<10	4.3

Parameter	Sample Date	Reported Influent Concentration (µg/L)	Reported Effluent Concentration (µg/L)	Most Stringent Objective (µg/L)
Copper, Total Recoverable	5/9/2011	7	2	4.3
Copper, Total Recoverable	11/10/2011	10	12	4.3
Copper, Total Recoverable	5/9/2012	<10	2	4.3
Copper, Total Recoverable	11/28/2012	1.35	4	4.3
Copper, Total Recoverable	5/1/2013	2	2	4.3
Copper, Total Recoverable	11/6/2013	9	1	4.3
Copper, Total Recoverable	11/18/2020	--	7	4.3
Copper, Total Recoverable	5/19/2021	280 (DNQ)	--	4.3
Lead, Total Recoverable	5/21/2009	0.3	0.3	0.99
Lead, Total Recoverable	11/18/2009	<0.2	<0.2	0.99
Lead, Total Recoverable	6/3/2010	1.1	0.8	0.99
Lead, Total Recoverable	11/3/2010	<10	<10	0.99
Lead, Total Recoverable	5/9/2011	1.3	0.3	0.99
Lead, Total Recoverable	11/10/2011	5.8	0.9	0.99
Lead, Total Recoverable	5/9/2012	<5	0.3	0.99
Lead, Total Recoverable	11/28/2012	0.0352	1	0.99
Lead, Total Recoverable	5/1/2013	1.2	1.5	0.99
Lead, Total Recoverable	11/6/2013	0.7	<0.2	0.99
Lead, Total Recoverable	11/18/2020	--	<5	0.99
Lead, Total Recoverable	5/19/2021	24 (DNQ)	--	0.99
Mercury, Total Recoverable	5/21/2009	0.08	0.24	0.012

Parameter	Sample Date	Reported Influent Concentration (µg/L)	Reported Effluent Concentration (µg/L)	Most Stringent Objective (µg/L)
Mercury, Total Recoverable	11/18/2009	0.07	0.24	0.012
Mercury, Total Recoverable	6/3/2010	0.09	0.2	0.012
Mercury, Total Recoverable	11/3/2010	0.1	0.06	0.012
Mercury, Total Recoverable	5/9/2011	0.31	0.31	0.012
Mercury, Total Recoverable	11/10/2011	0.16	0.25	0.012
Mercury, Total Recoverable	5/9/2012	0.25	0.27	0.012
Mercury, Total Recoverable	11/28/2012	0.1	0.25	0.012
Mercury, Total Recoverable	5/1/2013	0.28	0.51	0.012
Mercury, Total Recoverable	11/6/2013	0.17	0.42	0.012
Mercury, Total Recoverable	11/18/2020	--	1.2	0.012
Mercury, Total Recoverable	5/19/2021	39	--	0.012
Molybdenum, Total Recoverable	5/21/2009	63	60	10
Molybdenum, Total Recoverable	11/18/2009	62	56	10
Molybdenum, Total Recoverable	6/3/2010	71	53	10
Molybdenum, Total Recoverable	11/3/2010	60	50	10
Molybdenum, Total Recoverable	5/9/2011	64	64	10
Molybdenum, Total Recoverable	11/10/2011	59	64	10
Molybdenum, Total Recoverable	5/9/2012	60	56	10
Molybdenum, Total Recoverable	11/28/2012	62	50	10
Molybdenum, Total Recoverable	5/1/2013	63	56	10
Molybdenum, Total Recoverable	11/18/2020	--	62	10

Parameter	Sample Date	Reported Influent Concentration (µg/L)	Reported Effluent Concentration (µg/L)	Most Stringent Objective (µg/L)
Molybdenum, Total Recoverable	5/19/2021	68 (DNQ)	--	10

Based on influent data collected at the Facility since Order R6T-2009-0006 was issued, this condition is met because the observed maximum intake water concentration for each pollutant exceeds the most stringent water quality criterion/objective.

Condition 2. The intake water credits provided are consistent with any TMDL applicable to the discharge that has been approved by the Regional Water Board, State Water Board, and U.S. EPA.

Wendel Hot Springs is not currently considered a water quality-limited segment requiring a TMDL. Honey Lake, to which Wendel Hot Springs is tributary, is listed on the CWA Section 303(d) List of Water Quality Limited Segments requiring TMDLs; however, additional studies are needed to verify whether impairment exists and whether a TMDL is needed. Arsenic in Honey Lake is known to originate from natural sources. Based on a past study contracted by the Lahontan Water Board, arsenic concentrations fluctuate based on flux from the sediments depending primarily on the ambient water levels, evaporation and dilution by runoff (*Analysis of the Effect of Arsenic, Boron, and Molybdenum in Water Discharges on Water Quality in Honey Lake*, Ruschemeyer and Tchobanoglous, UC Davis 1989).

There is no known connection with Wendel Hot Springs and the Honey Lake Area Wetlands. The Honey Lake Area Wetlands is listed on the CWA Section 303(d) List of Water Quality Limited Segments requiring TMDLs for metals. This listing also requires additional studies to verify whether impairment exists and whether a TMDL is needed as the source of the impairment is unknown.

Condition 3. The intake water is from the same water body as the receiving water body. The discharger may demonstrate this condition by showing that: a) the ambient background concentration of the pollutant in the receiving water, excluding any amount of the pollutant in the facility's discharge, is similar to that of the intake water; b) there is a direct hydrological connection between the intake and discharge points; c) the water quality characteristics are similar in the intake and receiving waters; and d) the intake water pollutant would have reached the vicinity of the discharge point in the receiving water within a reasonable period of time and with the same effect had it not been diverted by the discharger.

While there is some natural variation, as discussed under Condition 1, the ambient background concentration of each of the pollutants in the receiving water (that is, the local hot springs) is similar to that of the intake water (that is, produced water). From February 2022 through July 2022, the Discharger

collected water samples from the surfacing Wendel Hot Springs for the six constituents with Intake Water Credits. Twelve samples were collected from two locations each. The canal sampling location is from the naturally surfacing geothermal water found in the canal/ditch immediately south of Antola Road and southeast of Discharge Point 001. The center pool location is from a surfacing pool of geothermal water near the center of Wendel Hot Springs. Both the canal and center pool locations ceased flowing when the power plant was operating. A summary of that data compared to the intake water reported during the 2009 and 2015 Orders is provided below:

Table F-6 – Facility Intake Water Compared to Surfacing Wendel Hot Springs

Parameter	Units	Facility Intake			Canal			Center Pool		
		Min	Med	Max	Min	Med	Max	Min	Med	Max
Arsenic	µg/L	157	199	290	190	210	220	190	210	240
Boron	µg/L	4400	5020	5600	4900	5200	5400	5000	5300	5500
Copper	µg/L	1	3	10	2	3.5	430	2	3	6
Lead	µg/L	0.0352	1.1	5.8	<2	5.5	8	<2	<2	<2
Mercury	µg/L	0.07	0.16	39	0.6	3.3	57	0.4	0.55	1.1
Molybdenum	µg/L	59	62	71	60	60	70	60	60	80

The data show the range of concentrations in the surfacing Wendel Hot Springs to be similar to the geothermal fluids from the production well, and that the concentrations of the surfacing water naturally vary in range.

There is a direct and long-recognized hydrological connection between the Facility intake and natural hot springs along a fault zone near the Facility. Historically, geothermal water rose from a deep reservoir (depth greater than 3,000 feet) and then surfaced as hot springs at the land surface. A report authored by GeothermEx, Inc. in 1984 titled, *Drilling History, Geology and Test Results of Wineagle #1 Well, Wendel, Lassen County, California for Carson Development Company, Sacramento, California* contains the following determination about the original siting location of the Wineagle #1 well prior to drilling: “The location for drilling Wineagle #1 was selected with the objective of intersecting a permeable fault at a depth of about 1,300 to 1,500 feet. The fault targeted for intersection is the same structure which is channeling water to Wendel Hot Springs.” Production from the Facility well diverts the upflowing geothermal water from its natural exit at the hot springs. When the well has been producing, the surfacing of geothermal water ceases. During the

production period from 1986-2018, Wendel Hot Springs did not see the naturally surfacing geothermal fluid. Moreover, when the well stops producing, Wendel Hot Springs reappears from the natural flow up the fault. When the Facility ceased power production in 2018, Wendel Hot Springs has resurfaced naturally discharging geothermal waters again.

Given the very small estimated volume of the fault zone, the constituents in the intake water would have reached the vicinity of the discharge point in the receiving water (hot springs or Honey Lake) within a matter of months, and in a similar concentration, had it not been diverted by production of geothermal water for the Facility.

Condition 4. The facility does not alter the intake water pollutant chemically or physically in a manner that adversely affects water quality and beneficial uses.

As previously discussed in this Fact Sheet, except for removal of heat from the extracted groundwater, the Facility does not alter the groundwater that is eventually discharged to the receiving water by the addition of chemicals or other pollutants.

Condition 5. The timing and location of the discharge does not cause adverse effects on water quality and beneficial uses that would not occur if the intake water pollutant had been left in the receiving water body.

The timing and location of the discharge from the Facility does not cause adverse effects on water quality and beneficial uses that would not occur if the pollutants in the intake water had been left in the intake water body, because (a) the hot springs will continue to surface geothermal water with similar pollutant concentrations and (b) there are no municipal uses of the water for either the local hot springs or Honey Lake.

Therefore, the Lahontan Water Board will allow intake water credits for arsenic, boron, copper, lead, mercury, and molybdenum. This credit is to offset elevated levels of these pollutants found in the intake water. As stated in section 1.4.4 of the SIP, the Lahontan Water Board "*may establish effluent limitations allowing the facility to discharge a mass and concentration of the intake water pollutant that is no greater than the mass and concentration in the facility's intake water ... so there is no net addition of the pollutant in the discharge compared to the intake water.*"

- 4.3.4.2.2. **Calculation of Intake Water Credits for Discharge Point 001.** To qualify for an intake water credit, the effluent pollutant concentration must be less than or equal to the intake pollutant concentration. However, intake and effluent data collected on the same day may differ due to factors unrelated to Facility operations, such as sampling and laboratory analytical variability. Since the residence time of geothermal water from intake to discharge is of relatively short duration, samples taken on the same day should be representative of the same water (assuming the samples are collected within a reasonably short time from each other). Concurrent influent and effluent samples were

not collected during the term of Order R6T-2015-0010. However, as shown in Table F-5, variability between the influent and effluent occurred throughout the term of previous Order R6T-2009-0006; for the same pollutants, there were times when the effluent concentrations were slightly higher than the influent concentrations, as well as instances when the influent concentrations were higher than effluent concentrations.

In order to account for the variability among the influent and effluent samples collected by the Discharger, the methodology for developing effluent limitations was revised. Since the residence time of geothermal water from intake to discharge is of relatively short duration and the Discharger does not alter the waste stream except for the removal of heat, the Lahontan Water Board has assumed the influent and effluent pollutant concentration are drawn from the same distribution. Thus, the log-transformed 99th percentile concentration of the available data from both the influent and effluent monitoring locations was calculated. The resulting 99th percentile value represents the upper range of the variability between intake and effluent pollutant concentrations due to sampling and analysis variability. When used as the basis for the effluent limitation, it results in an intake credit that captures the variability between influent and effluent data and prevents the discharge of additional pollutant mass. The 99th percentile effluent limit also implies that one percent of the time a value could occur that will exceed the 99th percentile, but a higher percentile might include extreme and possibly false values, which might mask a legitimate violation; a lower percentile might result in violations due to sample variability instead of the addition of pollutants. Since limited influent and effluent data was collected over the term of Order R6T-2015-0010, influent and effluent data collected at the Facility since Order R6T-2009-0006 was also considered for determining the 99th percentile effluent limits.

The maximum observed influent concentration for copper was 280 µg/L based on a May 19, 2021 sample collected by the Lahontan Water Board. Based on ten influent samples collected prior to the adoption of Order R6T-2015-0010, the maximum observed influent concentration for copper was 10 µg/L. According to the laboratory reports corresponding to the May 19, 2021 influent copper sample, the influent copper result of 280 µg/L is an estimated value and due to the sample matrix, the reporting limit was raised. Section 1.2 of the SIP states, "*The RWQCB shall have discretion to consider if any data are inappropriate or insufficient for use in implementing this Policy.*" The May 19, 2021 influent sample result for copper is an estimated value and appears to be an outlier compared to the remainder of the influent data collected since 2009. Therefore, the Lahontan Water Board has not considered the May 19, 2021 influent copper result when calculating the 99th percentile effluent limit.

The maximum observed influent concentration for mercury was 39 µg/L based on a May 19, 2021 sample collected by the Lahontan Water Board. Based on ten influent samples collected prior to the adoption of Order R6T-2015-0010,

the maximum observed influent concentration for mercury was 0.31 µg/L. Section 1.2 of the SIP states, “*The RWQCB shall have discretion to consider if any data are inappropriate or insufficient for use in implementing this Policy.*” The May 19, 2021 influent sample result for mercury appears to be an outlier compared to the remainder of the influent data collected since 2009. Therefore, the Lahontan Water Board has not considered the May 19, 2021 influent mercury result when calculating the 99th percentile effluent limit.

As described in section 4.3.3.3.2 of this Fact Sheet, the May 19, 2021 influent sample result for lead is an estimated value and appears to be an outlier compared to the remainder of the influent data collected since 2009. Additionally, the November 18, 2020 effluent monitoring event for lead was not conducted according to sufficiently sensitive test methods approved under 40 C.F.R. part 136. Therefore, the Lahontan Water Board has not considered the influent and effluent results for lead collected on May 19, 2021 and November 18, 2020, respectively, when calculating the 99th percentile effluent limit.

Consistent with SIP section 1.4.4, which requires the Facility to discharge a mass and concentration of the intake water pollutant that is no greater than the mass and concentration found in the Facility’s intake water. Where the 99th percentile value for a pollutant exceeds the maximum observed influent concentration, the maximum observed influent concentration is established as the effluent limitation. The final effluent limitations for arsenic, boron, copper, lead, mercury and molybdenum, which account for intake credits, are shown in the table below.

Table F-7. Final Effluent Limitations for Discharge Point 001

Parameter	Units	99th Percentile Value	Maximum Influent Concentration	Maximum Daily Effluent Limitation
Arsenic, Total Recoverable	µg/L	270	290	270
Boron, Total Recoverable	µg/L	6,200	5,700	5,700
Copper, Total Recoverable	µg/L	20	10	10
Lead, Total Recoverable	µg/L	18	5.8	5.8
Mercury, Total Recoverable	µg/L	1.1	0.31	0.31
Molybdenum, Total Recoverable	µg/L	74	71	71

The maximum daily effluent limits above were established by an intake credit analysis. If the intake geothermal water concentrations appear to be

increasing, intake credit analyses in conjunction with trend analyses may be necessary to establish revised effluent limitations. 40 C.F.R. section 122.45(d) requires, unless impracticable, that effluent limitations for continuous discharges be stated as maximum daily and average monthly effluent limitations. The method for deriving effluent limitations that account for pollutant concentrations in the intake to the Facility (i.e., intake credits) is based on statistically based upper bound (99th percentile) of the influent data. As such, this upper bound estimate is used to evaluate whether the Discharger contributes pollutant mass or concentrations above those levels contained in the influent to the Facility. Therefore, compliance with a maximum daily effluent limitation is considered more appropriate for this discharge situation where intake credits are being applied.

4.3.5. Whole Effluent Toxicity (WET)

No WET data exists for the discharge from the Facility. In light of the fact that no aquatic life designated uses apply to Wendel Hot Springs or Honey Lake, this Order does not require WET testing.

4.4. Final Effluent Limitation Considerations

4.4.1. Anti-Backsliding Requirements

Sections 402(o) and 303(d)(4) of the CWA and federal regulations at 40 C.F.R. section 122.44(l) prohibit backsliding in NPDES permits. These anti-backsliding provisions require effluent limitations in a reissued permit to be as stringent as those in the previous permit, with some exceptions where limitations may be relaxed. All effluent limitations in this Order are at least as stringent as the effluent limitations in the previous Order.

4.4.1.1. **Flow.** Order R6T-2015-0010 included flow as an effluent limit based on the Facility design flow. Compliance with the effluent limits for flow in Order R6T-2015-0010 was calculated based on the maximum daily effluent flow. Flow is not a pollutant and therefore has been changed from an effluent limit to a discharge prohibition in this Order, which is an equivalent level of regulation. This Order is not less stringent because compliance with flow as a discharge prohibition will be calculated the same way as the previous Order. Flow as a discharge prohibition adequately regulates the Facility, does not allow for an increase in the discharge of pollutants, and does not constitute backsliding.

4.4.2. Antidegradation Policies

The permitted surface water discharge is consistent with the antidegradation provisions of 40 C.F.R. section 131.12 and State Water Board Resolution 68-16. This Order does not allow for an increase in flow or mass of pollutants to the receiving water. Therefore, a complete antidegradation analysis is not necessary. The Order requires compliance with applicable federal technology-based standards and with WQBELs where the discharge could have the reasonable potential to cause or contribute to an exceedance of water quality standards. The permitted discharge is consistent with the antidegradation provisions of

40 C.F.R. section 131.12 and State Water Board Resolution 68-16. Compliance with these requirements will result in the use of best practicable treatment or control of the discharge. The impact on existing water quality will be insignificant.

It is also acknowledged that the Facility removes heat from the geothermal fluid to produce electricity and as a result discharges from the Facility will be slightly cooler than what would occur naturally. Based on semiannual monitoring data collected during the term of previous Order R6T-2009-0006, the discharge of the cooled geothermal effluent to the Wendel Hot Springs is approximately 25 degrees Celsius cooler than the temperature of the geothermal fluid as it is extracted. Since the discharge of the cooled geothermal fluid from the Facility has occurred since 1986, no further impacts to aquatic life from the continued discharge of the cooled geothermal fluid are expected in the Wendel Hot Springs.

From a broader perspective, any degradation that could occur as a result of discharges from the Facility is considered in the best interest of the people of the state. The Facility provides energy without producing greenhouse gas emissions that contribute to climate change, and as described in section 4.3.4, the mass and concentration of any pollutant discharged are expected to occur even in the absence of the Facility. The discharge from the Facility also provides fresh water that supports wetland habitats and potentially reduces salinity in Honey Lake, where the discharge ultimately reaches.

Therefore, the issuance of this Order is consistent with the federal antidegradation provisions of 40 C.F.R. section 131.12 and State Water Board Resolution 68-16.

4.4.3. **Stringency of Requirements for Individual Pollutants**

This Order contains both technology-based and water quality-based effluent limitations. Technology-based restrictions are discussed in section 4.2 of the Fact Sheet. This Order's technology-based pollutant restrictions implement the minimum, applicable federal technology-based requirements.

This Order includes WQBELs for arsenic, boron, copper, lead, mercury, and molybdenum at Discharge Point 001. WQBELs have been scientifically derived to implement water quality objectives that protect beneficial uses. Both the beneficial uses and the water quality objectives have been approved pursuant to federal law and are the applicable federal water quality standards. The scientific procedures for calculating the WQBELs are based on the SIP, which was approved by U.S. EPA on May 18, 2000. All beneficial uses and water quality objectives contained in the Basin Plan were approved under state law and submitted to and approved by U.S. EPA prior to May 30, 2000. Collectively, this Order's restrictions on individual pollutants are no more stringent than required to implement the requirements of the CWA.

4.5. Interim Effluent Limitations – Not Applicable

4.6. Land Discharge Specifications – Not Applicable

4.7. Recycling Specifications – Not Applicable

5. RATIONALE FOR RECEIVING WATER LIMITATIONS

The receiving water limitations in this Order are based upon the water quality objectives contained in the Basin Plan.

5.1. Surface Water

The Basin Plan contains numeric and narrative water quality objectives applicable to all surface waters within the Lahontan Region. Water quality objectives include an objective to maintain the high-quality waters pursuant to federal regulations (section 131.12) and State Water Board Resolution 68-16. Additionally, *Part 3 of the Water Quality Control Plan for Inland Surface Waters, Enclosed Bays, and Estuaries of California – Bacteria Provisions and a Water Quality Standards Variance Policy* (Statewide Bacteria Provisions) contains numeric water quality objectives for bacteria in waters with Water Contact Recreation (REC-1) beneficial use. Surface water limitations in this Order are included to ensure protection of beneficial uses of the receiving waters associated with Wendel Hot Springs.

The narrative objective for chemical constituents in the Basin Plan states that *“Waters shall not contain concentrations of chemicals that adversely affect the water beneficial uses.”* The receiving waters collectively have the following beneficial uses: Agricultural Supply (AGR); Groundwater Recharge (GWR); Freshwater Replenishment (FRSH); Hydropower Generation (POW); Water Contact Recreation (REC-1); Non-Contact Water Recreation (REC-2); Wildlife Habitat (WILD); and Water Quality Enhancement (WQE).

5.2. Groundwater

The Basin Plan contains numeric and narrative water quality objectives applicable to all groundwaters within the Lahontan Region. Groundwater quality objectives include an objective to maintain the high-quality waters pursuant to State Water Board Resolution 68-16. Groundwaters in the Honey Lake Valley Basin may not meet all objectives for applicable beneficial uses due to natural factors, including natural geothermal activity. Site specific monitoring and analyses are, in general, needed to establish the local groundwater quality conditions. Groundwater limitations in this Order are included to ensure protection of background water quality and beneficial uses of groundwater that may be affected by discharges.

6. RATIONALE FOR PROVISIONS

6.1. Standard Provisions

Standard Provisions, which apply to all NPDES permits in accordance with 40 C.F.R. section 122.41, and additional conditions applicable to specified categories of permits in accordance with 40 C.F.R. section 122.42, are provided in

Attachment D. The Discharger must comply with all standard provisions and with those additional conditions that are applicable under section 122.42.

Sections 122.41(a)(1) and (b) through (n) of 40 C.F.R. establish conditions that apply to all state-issued NPDES permits. These conditions must be incorporated into the permits either expressly or by reference. If incorporated by reference, a specific citation to the regulations must be included in the Order.

Section 123.25(a)(12) of 40 C.F.R. allows the state to omit or modify conditions to impose more stringent requirements. In accordance with 40 C.F.R. section 123.25, this Order omits federal conditions that address enforcement authority specified in 40 C.F.R. sections 122.41(j)(5) and (k)(2) because the enforcement authority under the Water Code is more stringent. In lieu of these conditions, this Order incorporates by reference Water Code section 13387(e).

6.2. Special Provisions

6.2.1. Reopener Provisions

These provisions are based on 40 C.F.R. section 122.62 and allow modification of this Order and its effluent limitations as necessary in response to updated water quality objectives, regulations, or other new relevant information that may be established in the future and other circumstances as allowed by law.

6.2.2. Special Studies and Additional Monitoring Requirements – Not Applicable

6.2.3. Best Management Practices and Pollution Prevention

6.2.3.1. Best Management Practices Plan. This Order requires that the Discharger develop and implement a Best Management Practices (BMP) Plan. The BMP Plan requirements are specified in Attachment G to the Order, which are consistent with the general guidance contained in the U.S. EPA *Guidance Manual for Developing Best Management Practices (BMPs)* (EPA 833-B-93-004).

6.2.4. Construction, Operation, and Maintenance Specifications – Not Applicable

6.2.5. Special Provisions for Publicly-Owned Treatment Works (POTWs) – Not Applicable

6.2.6. Other Special Provisions – Not Applicable

6.2.7. Compliance Schedules – Not Applicable

7. RATIONALE FOR MONITORING AND REPORTING REQUIREMENTS

CWA section 308 and 40 C.F.R. sections 122.41(h), (j)-(l), 122.44(i), and 122.48 require that all NPDES permits specify monitoring and reporting requirements. Water Code sections 13267 and 13383 also authorize the Lahontan Water Board to establish monitoring, inspection, entry, reporting, and recordkeeping requirements. The Monitoring and Reporting Program (MRP), Attachment E of this Order establishes monitoring, reporting, and recordkeeping requirements that implement federal and state requirements. The following provides the rationale for the monitoring and reporting requirements contained in the MRP for this Facility.

7.1. Influent Monitoring

Influent monitoring is required to collect data on the characteristics of the wastewater and to assess compliance with effluent limitations (i.e., use for calculating intake credits).

7.1.1. Monitoring Location INF-001

7.1.1.1. Influent monitoring frequencies (2/Year) and sample type (grab) for arsenic, boron, copper, lead, mercury, and molybdenum have been retained from Order R6T-2015- 0010 to assess the levels of pollutants in the extracted groundwater for these parameters. In addition, the influent monitoring frequencies and sample type for flow, pH, hardness, and temperature have been retained from Order R6T-2015- 0010 to assess the quality of the influent for these parameters.

7.1.1.2. This Order requires semiannual influent monitoring for bis (2-ethylhexyl) phthalate to assess the quality of the influent for this parameter and requires the Discharger to take steps to assure that sample containers, sampling apparatus, and analytical equipment are not sources of the detected contaminant.

7.1.1.3. Monitoring data collected over the term of Order R6T-2015- 0010 for zinc did not demonstrate reasonable potential to exceed water quality objectives/criteria. Thus, specific monitoring requirements for zinc have not been retained from Order R6T-2015- 0010.

7.1.1.4. Due to the potential presence of priority pollutants in high concentrations in the influent over which the Discharger has no control, this Order retains the periodic monitoring requirement from Order R6T-2015- 0010 for priority pollutants. This Order requires monitoring twice (May and November) during the fourth year of the permit term, concurrent with effluent priority pollutant monitoring, to collect data for priority pollutants (including hardness) and conduct an assessment of the quality of the influent for the next permit renewal.

7.2. Effluent Monitoring

Pursuant to the requirements of 40 C.F.R. section 122.44(i)(2), effluent monitoring is required for all constituents with effluent limitations. Effluent monitoring is necessary to assess compliance with effluent limitations, and to assess the impacts of the discharge on the receiving stream and groundwater.

7.2.1. Monitoring Location EFF-001

7.2.1.1. Effluent monitoring frequencies (2/Year) and sample type (grab) for arsenic, boron, copper, lead, mercury, and molybdenum have been retained from Order R6T-2015- 0010 to determine compliance with effluent limitations for these parameters. In addition, the effluent monitoring frequencies and sample type for flow, pH, hardness, and temperature have been retained from Order R6T-2015- 0010 to assess the quality of the effluent for these parameters.

- 7.2.1.2. This Order requires semiannual effluent monitoring for bis (2-ethylhexyl) phthalate to assess the quality of the effluent for this parameter and requires the Discharger to take steps to assure that sample containers, sampling apparatus, and analytical equipment are not sources of the detected contaminant.
- 7.2.1.3. Monitoring data collected over the term of Order R6T-2015- 0010 for zinc did not demonstrate reasonable potential to exceed water quality objectives/criteria. Thus, specific monitoring requirements for zinc have not been retained from Order R6T-2015- 0010.
- 7.2.1.3. In accordance with section 1.3 of the SIP, periodic monitoring for priority pollutants for which criteria or objectives apply and for which no effluent limitations have been established is required. This Order requires monitoring twice (May and November) during the fourth year of the permit term, concurrent with influent priority pollutant monitoring, in order to collect data for priority pollutants (including hardness) and conduct an RPA for the next permit renewal.

7.3. Whole Effluent Toxicity Testing Requirements – Not Applicable

7.4. Receiving Water Monitoring

Due to the fact that the Facility well diverts upflowing geothermal water from its natural exit at the hot springs, there is no upstream receiving water. Further, the immediate discharge at the Facility to the Wendel Hot Springs area makes monitoring downstream of the discharge impractical. The monitoring requirements contained in this Order for the influent to the Facility (i.e., the geothermal water as it exits the well), will be used to characterize the background surface and ground water.

7.5. Other Monitoring Requirements – Not Applicable

8. PUBLIC PARTICIPATION

The Lahontan Water Board has considered the issuance of WDRs that will serve as an NPDES permit for the Wendel Geothermal Power Plant. As a step in the WDR adoption process, the Lahontan Water Board staff has developed tentative WDRs and has encouraged public participation in the WDR adoption process.

8.1. Notification of Interested Parties

The Lahontan Water Board notified the Discharger and interested agencies and persons of its intent to prescribe WDRs for the discharge and provided an opportunity to submit written comments and recommendations. Notification and the proposed Order was provided on the Lahontan Water Board Website and to all known interested parties.

The public had access to the agenda and any changes in dates and locations through the Lahontan Water Board's website at <https://www.waterboards.ca.gov/lahontan/>

8.2. Written Comments

Interested persons were invited to submit written comments concerning tentative WDRs as provided through the notification process. Comments were due either in person or by mail to the Executive Office at the Lahontan Water Board at the address on the cover page of this Order.

To be fully responded to by staff and considered by the Lahontan Water Board, the written comments were due at the Lahontan Water Board office by 5:00 p.m. on **April 12, 2022**.

On August 18, 2022, revisions to the Order were released for a limited scope review and public comment period. Interested persons were invited to submit written comments according to the Water Board's Public Notice of Available Document for Limited Scope Review and Comment (August 18, 2022).

Comments were due either in person or by mail to the Executive Office at the Lahontan Water Board at the address on the cover of this Order. To be fully responded to by staff and considered by the Lahontan Water Board, the written comments were due at the Lahontan Water Board office by 5:00 p.m. on **September 19, 2022**.

8.3. Public Hearing

The Lahontan Water Board held a public hearing on the proposed WDRs during its regular Board meeting on the following date and time and at the following location:

Date: June 9, 2022
Time: 9:00 am
Location: Hampton Inn and Suites,
2710 Lenwood Road Barstow Ca 92311
And via Video and teleconference

The Lahontan Water Board reopened and continued the public hearing on the proposed WDRs/NPDES permit during its regular Board meeting at the following date and time and at the following location:

Date: November 9, 2022
Time: 9:00am
Location: Video and teleconference only

Interested persons were invited to attend. At the public hearing, the Lahontan Water Board heard testimony pertinent to the discharge, WDRs, and permit. For accuracy of the record, important testimony was requested in writing.

8.4. Review of Waste Discharge Requirements

Any person aggrieved by this action of the Lahontan Water Board may petition the State Water Board to review the action in accordance with Water Code section 13320 and California Code of Regulations, title 23, sections 2050 and following. The State Water Board must receive the petition by 5:00 p.m., within 30 calendar days of the date of adoption of this Order at the following address, except that if the thirtieth day following the date of this Order falls on a Saturday,

Sunday, or state holiday, the petition must be received by the State Water Board by 5:00 p.m. on the next business day:

State Water Resources Control Board
Office of Chief Counsel
P.O. Box 100, 1001 I Street
Sacramento, CA 95812-0100

Or by email at waterqualitypetitions@waterboards.ca.gov

For [instructions on how to file a water quality petition for review](#), see:
(http://www.waterboards.ca.gov/public_notices/petitions/water_quality/wqpetition_instr.shtml)

8.5. Information and Copying

The ROWD, other supporting documents, and comments received are on file and may be inspected at the address above at any time between 8:30 a.m. and 4:45 p.m., Monday through Friday. Copying of documents may be arranged through the Lahontan Water Board by calling (530) 542-5400.

8.6. Register of Interested Persons

Any person interested in being placed on the mailing list for information regarding the WDRs and NPDES permit should contact the Lahontan Water Board, reference this facility, and provide a name, address, and phone number.

8.7. Additional Information

Requests for additional information or questions regarding this order should be directed to Trevor Miller at (530) 542-5430.

ATTACHMENT G – BEST MANAGEMENT PRACTICES PLAN REQUIREMENTS

- 1. Implementation.** The Discharger must develop and implement a Best Management Practices (BMP) Plan that achieves the objectives and the specific requirements listed below. The BMP Plan must be implemented as soon as possible, but no later than 120 days from the effective date of this Order. The Discharger must also submit a copy of the BMP Plan to the Executive Officer within 120 days from the effective date of this Order.
- 2. Purpose.** Through implementation of the BMP Plan the Discharger must prevent or minimize the generation and the potential for the release of pollutants from the Wendel Geothermal Power Plant to the waters of the United States through normal operations and ancillary activities.
- 3. Objectives.** The Discharger must develop the BMP Plan consistent with the following objectives for the control of pollutants:
 - 3.1. The number and quantity of pollutants and the toxicity of effluent generated, discharged or potentially discharged from the Wendel Geothermal Power Plant must be reduced by the Discharger to the extent feasible by managing each influent waste stream in the most appropriate manner.
 - 3.2. Under the BMP Plan, and any Standard Operating Procedures (SOPs) included in the Plan, the Discharger must ensure proper operation and maintenance of the Wendel Geothermal Power Plant. The Discharger must establish specific objectives for the control of pollutants by conducting the following evaluations.
 - 3.2.1. Each facility component or system must be examined for its waste minimization opportunities and its potential for causing a release of pollutants that would violate water quality objectives for waters of the United States due to equipment failure, improper operation, and natural phenomena such as rain or snowfall, etc. The examination must include all normal operations and ancillary activities including, for example, material storage areas, plant site runoff, in-plant transfer, process and material handling areas, loading or unloading operations, spillage or leaks, sludge and waste disposal, or drainage from raw material storage.
 - 3.2.2. Where experience or reason indicates a reasonable potential for equipment failure (e.g., a tank overflow or leakage), natural condition (e.g., precipitation), or other circumstances to release pollutants that would violate water quality objectives for waters of the United States, the program should include a prediction of the direction, rate of flow and total quantity of pollutants which could be discharged from the facility as a result of each condition or circumstance.
- 4. Requirements.** The BMP Plan must be consistent with the objectives in Part 3 above and the general guidance contained in the publication entitled *Guidance Manual for Developing Best Management Practices (BMPs)* (U.S. EPA, 1993) or any subsequent revisions to the guidance document. The BMP Plan must:

- 4.1. Be documented in narrative form, must include any necessary plot plans, drawings or maps, and must be developed in accordance with good engineering practices. The BMP Plan must be organized and written with the following structure:
 - 4.1.1. Name and location of the facility.
 - 4.1.2. Statement of BMP policy.
 - 4.1.3. Specific management practices and standard operating procedures to achieve the above objectives, including, but not limited to, the following:
 - 4.1.3.1. Modification of equipment, facilities, technology, processes, and procedures;
 - 4.1.3.2. Reformulation or redesign of products;
 - 4.1.3.3. Substitution of materials; and
 - 4.1.3.4. Improvement in management, inventory control, materials handling or general operational phases of the Facility.
 - 4.1.4. Risk identification and assessment.
 - 4.1.5. Reporting of BMP incidents.
 - 4.1.6. Materials compatibility.
 - 4.1.7. Good housekeeping.
 - 4.1.8. Preventative maintenance.
 - 4.1.9. Inspections and records.
 - 4.1.10. Security.
 - 4.1.11. Employee Training.
- 4.2. Include the following provisions concerning BMP Plan review:
 - 4.2.1. Be reviewed by plant engineering staff and the plant manager.
 - 4.2.2. Include a statement that the above reviews have been completed and that the BMP Plan fulfills the requirements set forth in this permit.
- 4.3. Establish specific BMPs to meet the objectives identified in part 3 of Attachment G, addressing each component or system capable of generating or causing a release of significant amounts of pollutants, and identifying specific preventative or remedial measures to be implemented.
- 4.4. Establish specific best management practices or other measures which ensure that the following specific requirements are met:
 - 4.4.1. If applicable, ensure proper management of solid and hazardous waste in accordance with regulations promulgated under the Resource Conservation and Recovery Act (RCRA). Management practices required under RCRA regulations must be referenced in the BMP Plan.
 - 4.4.2. If applicable, reflect requirements for Spill Prevention, Control, and Countermeasure (SPCC) plans under Section 311 of the Act and

40 C.F.R. part 112 and may incorporate any part of such plans into the BMP Plan by reference.

- 4.4.3. If applicable, reflect requirements for storm water control under section 402(p) of the Act and the regulations at 40 C.F.R. sections 122.26 and 122.44, and otherwise eliminate to the extent practicable, contamination of storm water runoff.
- 4.4.4. No discharge during or 48 hours after cleaning or maintenance dredging work performed in the spray cooling ponds that would suspend and/or dissolve arsenic and metal-laden sediments.
- 5. Documentation.** The Discharger must maintain a copy of the BMP Plan at the facility and must make the plan available to the Lahontan Water Board upon request. All offices of the Discharger that are required to maintain a copy of the NPDES permit must also maintain a copy of the BMP Plan.
- 6. BMP Plan Modification.** The Discharger must amend the BMP Plan whenever there is a change in the facility or in the operation of the facility which materially increases the generation of pollutants or their release or potential release to the receiving waters. The Discharger must also amend the Plan, as appropriate, when plant operations covered by the BMP Plan change. Any such changes to the BMP Plan must be consistent with the objectives and specific requirements listed above. All changes in the BMP Plan must be reported to the Lahontan Water Board in writing.
- 7. Modification for Ineffectiveness.** At any time, if the BMP Plan proves to be ineffective in achieving the general objective of preventing and minimizing the generation of pollutants and their release and potential release to the receiving waters and/or the specific requirements above, the permit and/or the BMP Plan must be subject to modification to incorporate revised BMP requirements.