

Tetra Tech Inc.

# Attachment B: Evaluation of Multi- Benefit Projects

# CONTENTS

---

List of Tables .....	iii
List of Figures.....	iii
Acronyms/ abbreviations .....	iv
<b>EXECUTIVE SUMMARY .....</b>	<b>V</b>
<b>1.0 INTRODUCTION .....</b>	<b>6</b>
<b>2.0 BACKGROUND AND EXISTING CONDITIONS.....</b>	<b>6</b>
2.1 Individual Site Conditions.....	8
2.1.1 Arcadia Arboretum Natural Treatment and Groundwater Recharge Project .....	8
2.1.2 Rio Hondo Ecosystem Restoration Project and Arcadia Wash Water Conservation Diversion .....	10
2.1.3 Encanto Park Stormwater Capture Project .....	14
2.1.4 Basin 3E Enhancements at Santa Fe Spreading Grounds Project.....	16
<b>3.0 WATER QUALITY ANALYSIS .....</b>	<b>18</b>
3.1 Drainage Area Delineation .....	18
3.1.1 Rio Hondo Drainage .....	19
3.1.2 San Gabriel River Drainage.....	19
3.1.3 Big Dalton Wash Drainage .....	19
3.1.4 Eaton Wash Drainage .....	19
3.2 Optimization Modeling.....	19
3.2.1 Rio Hondo Optimization Results .....	20
3.2.2 San Gabriel River Optimization .....	21
3.2.3 Big Dalton Wash and Eaton Wash .....	22
<b>4.0 PROPOSED CONCEPTS .....</b>	<b>22</b>
4.1 Arcadia Arboretum Natural Treatment and Groundwater Recharge Project .....	23
4.1.1 Potential Constraints .....	24
4.2 Rio Hondo Ecosystem Restoration Project and Arcadia Wash Water Conservation Diversion .....	25
4.2.1 Phase 1 – Arcadia Wash Water Conservation Diversion .....	25
4.2.2 Phase 2 – Rio Hondo Ecosystem Restoration Project.....	26
4.2.4 Potential Constraints .....	27
4.3 Encanto Park Stormwater Capture Project .....	28
4.3.1 Potential Constraints .....	29
4.4 Basin 3E Enhancements at Santa Fe Spreading Grounds Project .....	30
4.4.2 Potential Constraints .....	31

<b>5.0 LONG TERM MONITORING</b> .....	<b>32</b>
<b>6.0 SCHEDULE AND COST ESTIMATES</b> .....	<b>32</b>
6.1 Project Schedule .....	32
6.2 Construction Cost.....	33
6.3 Project Implementation Costs .....	33
6.4 Operations and Maintenance Costs.....	34
<b>7.0 REGULATORY AND PERMITTING EVALUATION</b> .....	<b>34</b>
7.1 Regional Water Quality Control Board, LOs Angeles REgion (NPDES Permit No. CAS004001).....	35
7.2 South Coast Air Quality Management District.....	35
7.3 Los Angeles County Flood Control District .....	35
7.4 US Army Corps of Engineers (USACE) Section 408 Permit .....	36
7.5 CEQA/NEPA .....	36
7.5.1 Historical Resources.....	36
7.5.2 Archaeological Resources.....	36
7.5.3 Paleontological Resources .....	37
7.5.4 Burial Sites.....	37
7.6 Local Permits .....	37
<b>8.0 CONCLUSION AND RECOMMENDATIONS</b> .....	<b>37</b>
<b>9.0 REFERENCES</b> .....	<b>39</b>
<b>APPENDIX B.1 ARCADIA ARBORETUM NATURAL TREATMENT AND GROUNDWATER RECHARGE PROJECT EVALUATION</b> .....	<b>1</b>
<b>APPENDIX B.2 RIO HONDO ECOSYSTEM RESTORATION PROJECT AND ARCADIA WASH WATER CONSERVATION DIVERSION EVALUATION</b> .....	<b>2</b>
<b>APPENDIX B.3 ENCANTO PARK STORMWATER CAPTURE PROJECT EVALUATION</b> .....	<b>3</b>
<b>APPENDIX B.4 BASIN 3E ENHANCEMENTS AT SANTA FE SPREADING GROUNDS PROJECT EVALUATION</b> .....	<b>4</b>
<b>APPENDIX B.5 POTENTIAL GREEN STREET PROJECTS AND EXAMPLE CONFIGURATIONS AND DETAILS</b> .....	<b>5</b>

## LIST OF TABLES

---

Table 1. Regional Drainage Area .....	7
Table 2. Rio Hondo Regional BMP Optimization Results .....	21
Table 3. San Gabriel River Regional BMP Optimization Results .....	22
Table 4. Green Streets Summary .....	22
Table 5. Project Schedule Summary .....	33
Table 6. Estimated Capital Construction Costs for Proposed BMP Sites .....	33
Table 7. Project Delivery Costs .....	34
Table 8. Total Project Implementation Costs Summarized .....	34
Table 9. Regional BMP Project Summary Table .....	37
Table 10. Green Street Recommendation Summary Table .....	38

## LIST OF FIGURES

---

Figure 1. Regional BMP and Potential Green Street Locations .....	7
Figure 2. Arcadia Wash Arboretum Natural Treatment and Groundwater Recharge Project Drainage Area and Location Map .....	8
Figure 3. Arcadia Arboretum Natural Treatment and Groundwater Recharge Project Existing Conditions .....	9
Figure 4. Arcadia Wash Water Conservation Diversion Drainage Area and Location Map .....	10
Figure 5. Arcadia Wash Existing Conditions Map .....	11
Figure 6. Rio Hondo Ecosystem Restoration Project Drainage Area and Location Map .....	12
Figure 7. Rio Hondo Ecosystem Restoration Project Existing Site Conditions .....	13
Figure 8. Encanto Park Stormwater Capture Project Existing Site Conditions .....	14
Figure 9. Encanto Park Existing Conditions Map .....	15
Figure 10. Basin 3E Drainage Area and Location Map .....	16
Figure 11. Basin 3E Enhancements at Santa Fe Spreading Grounds Existing Site Conditions .....	17
Figure 12. Water Quality Compliance Points .....	18
Figure 13. Cost-Effectiveness Curve for Regional Projects within the Rio Hondo Drainage Area (note that modeled costs are relative – see engineering cost estimated in each appendix) .....	20
Figure 14. Cost-Effectiveness Curve for Regional Projects within the San Gabriel River Drainage Area (note that modeled costs are relative – see engineering cost estimated in each appendix) .....	21
Figure 15. Site Layout for Arcadia Arboretum Natural Treatment and Groundwater Recharge Project .....	23
Figure 16. Rendering of the Arboretum Wet and Dry Ponds in Wet Weather .....	24
Figure 17. Phase 1 Site Layout – Arcadia Wash Water Conservation Diversion .....	25
Figure 18. Phase 2 – Rio Hondo Ecosystem Restoration Project .....	26
Figure 19. Encanto Park Stormwater Capture Project Site Layout .....	28
Figure 20. Rendering of Proposed Subsurface Structure at Encanto Park .....	29
Figure 21. Basin 3E Enhancements at Santa Fe Spreading Grounds Site Layout .....	30
Figure 22. Rendering of Proposed Basin 3E Enhancements .....	31
Figure 23. Santa Fe Spreading Grounds Adjacent to Basin 3E Schematic .....	32

## ACRONYMS/ ABBREVIATIONS

Acronyms/Abbreviations	Definition
BMP	Best Management Practice
EWMP	Enhanced Watershed Management Program
LACFCD	Los Angeles County Flood Control District
LID	Low Impact Development
Los Angeles Regional Board	California Regional Water Quality Control Board, Los Angeles Region
LSPC	Loading Simulation Program in C++
MCM	Minimum Control Measure
MS4	Multiple Separate Storm Sewer System
MS4 Permit	Los Angeles Regional Board Order R4-2012-0175, <i>Waste Discharge Requirements for Municipal Separate Storm Sewer System (MS4) Discharges within the Coastal Watersheds of Los Angeles County, except those Discharges Originating from the City of Long Beach MS4</i>
RAA	Reasonable Assurance Analysis
rEWMP	Revised Enhanced Watershed Management Plan
RH	Rio Hondo
RH/SGR WQG	Rio Hondo/San Gabriel River Water Quality Group
SFSG	Santa Fe Spreading Grounds
SGR	San Gabriel River
SUSTAIN	System for Urban Stormwater Treatment and Analysis Integration
SWPPP	Storm Water Pollution Prevention Plan
TMDL	Total Maximum Daily Load
WMMS	LACFCD's Watershed Management Modeling System
WMP	Watershed Management Program
WY	Water Year
USEPA	US Environmental Protection Agency

# EXECUTIVE SUMMARY

## Project Overview

This report was developed to evaluate the Rio Hondo/San Gabriel River Water Quality Group's (RH/SGR WQG) four (4) multi-benefit regional projects identified in the revised Enhances Watershed Management Plan (rEWMP) for the RH/SGR. In order to address the water quality limits as set forth in the rEWMP, the objective of this pre-feasibility study was to evaluate the development of the regional projects listed below:

1. Arcadia Arboretum Natural Treatment and Groundwater Recharge Project
2. Rio Hondo Ecosystem Restoration Project and Arcadia Wash Water Conservation Diversion
3. Encanto Park Stormwater Capture Project
4. Basin 3E Enhancements at Santa Fe Spreading Grounds Project

The pre-feasibility study addresses feasibility with respect to each site's implementation and operations. The implementation components include expected design flows, water quality, potential for infiltration, identification of major components and equipment, and basic site layouts. The study will then provide estimates for operations and maintenance needs and cost.

## Water Quality Context

The RH/SGR rEWMP area, consisting of the County of Los Angeles and the Cities, Arcadia, Bradbury, Duarte, Monrovia, and Sierra Madre, contains mostly residential area as well steep slopes from the San Gabriel Mountains. The rEWMP watershed management area (19,416 acres) is comprised of three major drainage systems: Rio Hondo, San Gabriel River, and Big Dalton Wash.

The highest priority pollutant addressed by the rEWMP is metals, which based on the TMDL established by the Regional Board as well as an assessment of pollutant loadings at the compliance points selected for the EWMP jurisdictions. The rEWMP analysis specifically identified zinc as the pollutant driving implementation of new pollutant source control and watershed control measures. This report evaluates the potential to meet the RH/SGR rEWMP water quality compliance targets through the cumulative performance of the proposed regional BMP's, in addition to the contribution from enhanced Minimum control measures (MCMs) and non-structural distributed BMPs. The study includes recommendations for the optimal design and configuration of the proposed facilities, with further discussion on the MCMs provided in Attachment C (Revise Reasonable Assurance Analysis).

## Project Concept Performance

Through the collaborative effort with the RH/SGR WQG, Tetra Tech developed optimized project concepts focused on maximizing pollutant load reduction based on diversion rates and available project area. This regional project evaluation details the optimal project designs for the four regional projects and distributed green streets, their associated performance, and costs. The combined performance of the final proposed regional BMP configurations meets and exceeds the rEWMP's pollutant reduction compliance targets, while minimizing footprint sizes. An appendix for each regional site provides the details of its respective project concept.

## 1.0 INTRODUCTION

The Rio Hondo/San Gabriel River Water Quality Group (RH/SGR WQG) is comprised of the County of Los Angeles, Los Angeles County Flood Control District (LACFCD) and the Cities of Azusa, Arcadia, Bradbury, Duarte, Monrovia, and Sierra Madre. While the City of Azusa was a member of this WQG, they have elected to continue implementing the 2016 EWMP within their jurisdictional area, and therefore are not included as a member agency participating in this rEWMP update. The RH/SGR WQG has developed a Revised Enhanced Watershed Management Program (rEWMP) to address concerns with their existing EWMP as well as expand it to include multi-benefit regional best management practice (BMP) projects. The potential stormwater BMPs discussed in this feasibility study will be an opportunity for the WQG to address multi-benefit goals, such as site development, regional water quality improvements, recreational open space, and habitat development. The proposed regional BMP projects are listed below:

1. Arcadia Arboretum Natural Treatment and Groundwater Recharge Project
2. Rio Hondo Ecosystem Restoration Project and Arcadia Wash Water Conservation Diversion
3. Encanto Park Stormwater Capture Project
4. Basin 3E Enhancements at Santa Fe Spreading Grounds Project

These stormwater BMPs will be a critical component to addressing the WQG's water quality treatment objectives as stated in the RH/SGR rEWMP. Additional distributed BMPs such as green streets will also be implemented where additional treatment is required to meet the water quality targets.

The analysis performed for each proposed regional structural BMP project demonstrates opportunities for how smart and innovative design can help the RH/SGR WQG comply with its TMDLs and permits by maximizing their water quality benefits, but also identify the potential for multiple additional benefits, such as water supply and community amenities. This feasibility study outlines the analysis performed for each of the proposed regional BMP sites in consideration.

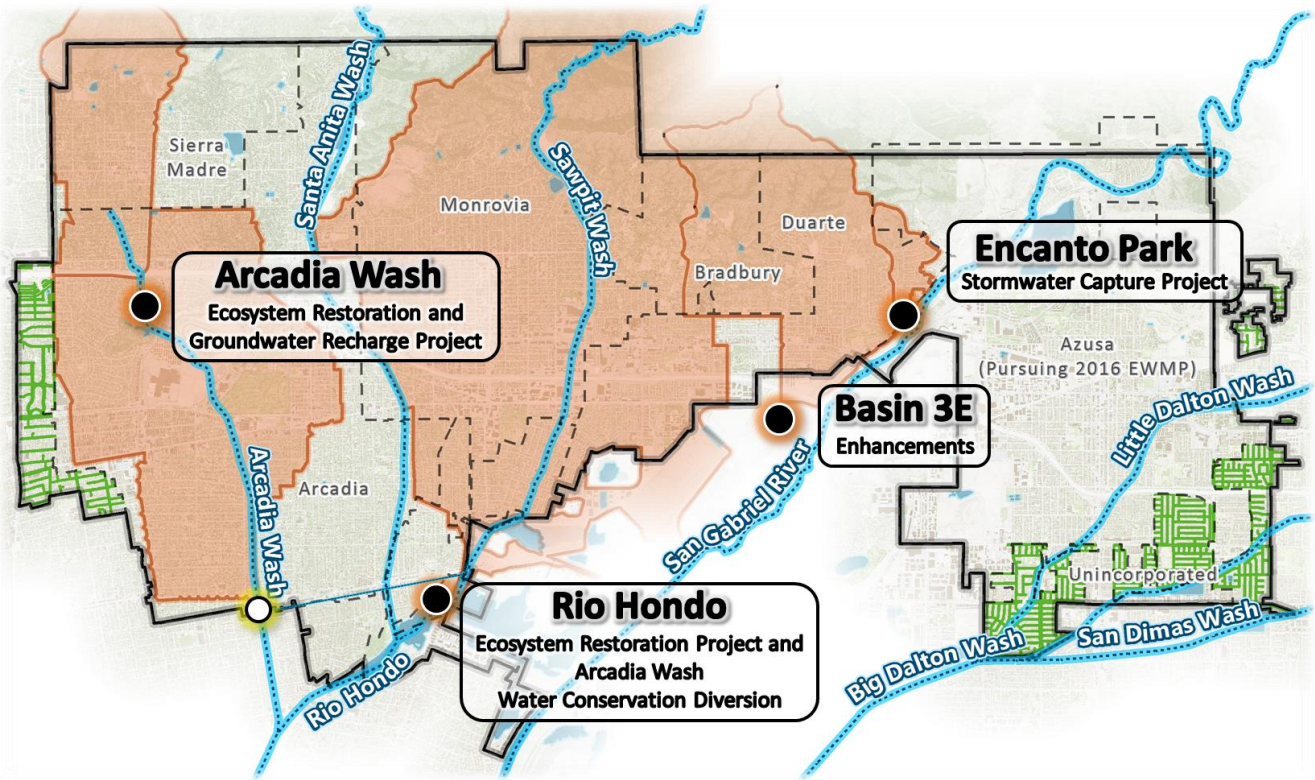
## 2.0 BACKGROUND AND EXISTING CONDITIONS

The rEWMP watershed management area (19,416 acres) is comprised of four major drainage systems: Rio Hondo, San Gabriel River and Big Dalton Wash. A small portion of the western rEWMP watershed management area drains west to Eaton Wash. The Big Dalton Wash drainage areas is a hydrologically linked sub watersheds tributary to the San Gabriel River. The Eaton Wash Watershed is tributary to the Rio Hondo Watershed, which are both tributary to the downstream Los Angeles River Watershed. The San Gabriel River drainage area is comprised mainly of the San Gabriel Mountains. The Rio Hondo and Big Dalton Wash drainage areas include a combination of both natural mountainous terrain and urban built out area. See **Table 1** for a summary of the tributary areas. Also included in the table is a column for areas considered "sump" area because they do not drain to anywhere within the EWMP boundary, meaning that in the watershed model this area does not have a downstream reach. Also, the total drainage area in the table includes area downstream of the revised EWMP boundary because this area is tributary to the compliance points being analyzed. Compliance points were selected to capture the entire drainage area contributed from the EWMP boundary.

**Table 1.** Regional Drainage Area

	Rio Hondo	San Gabriel River	Big Dalton Wash	Eaton Wash	Sump Area
Total Drainage Area (acres)	31,345	153,282	24,238	n/a	n/a
Revised EWMP Boundary (acres)	15,870	2,198	1,348	829	387
Percent of rEWMP Boundary	62%	9%	5%	4%	n/a
Additional Area Downstream (acres)	2,065	2,312	861	n/a	n/a

The RH/SGR WQG is proposing four regional BMP projects to meet the compliance targets set forth in the rEWMP. The location of these regional BMPs can be seen in **Figure 1**. Regional BMP and Potential Green Street Locations below. The locations of the proposed regional BMPs were chosen due to their potential for providing maximum water quality benefits for the downstream receiving waters. The majority of the tributary area is urbanized, with only a portion still in its natural condition.



**Figure 1.** Regional BMP and Potential Green Street Locations

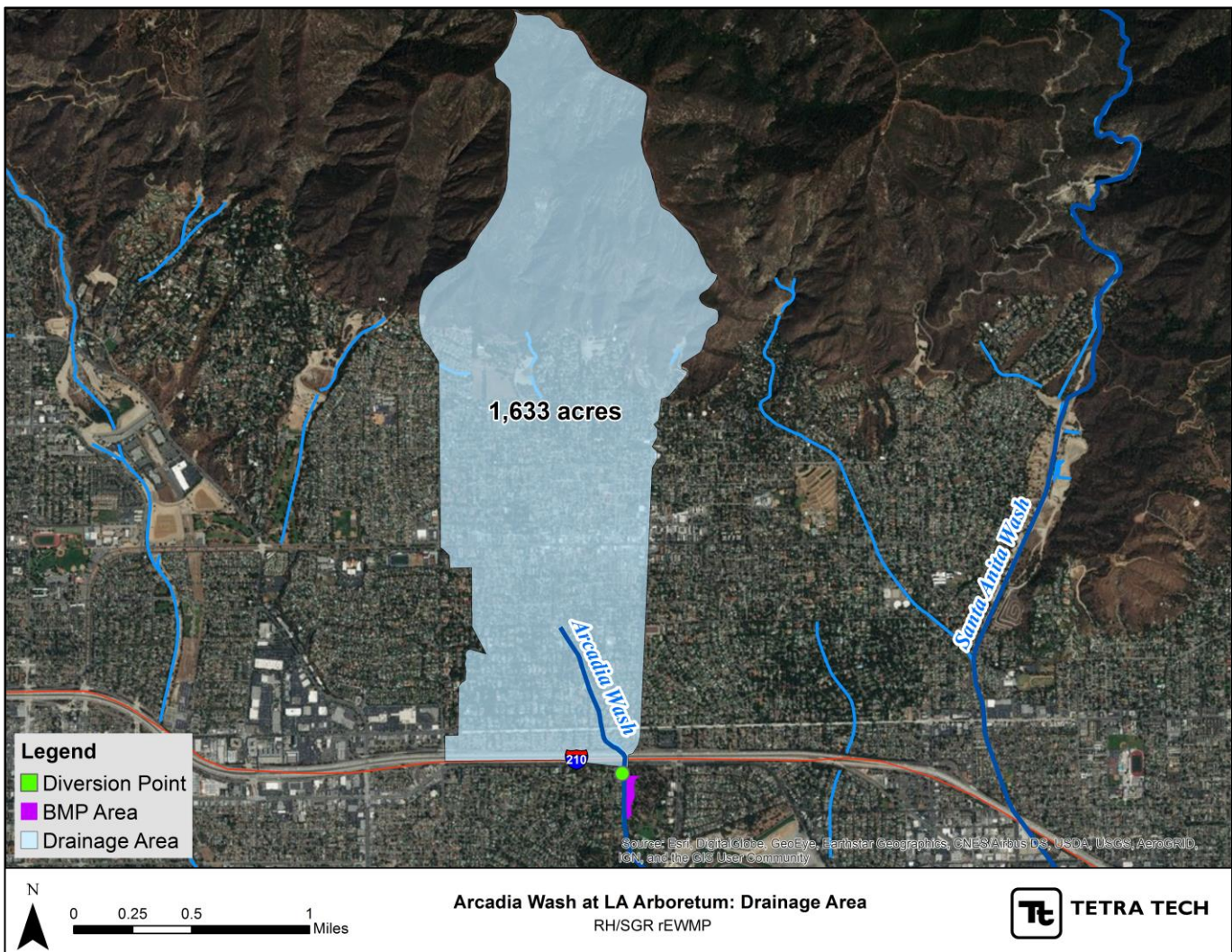


## 2.1 INDIVIDUAL SITE CONDITIONS

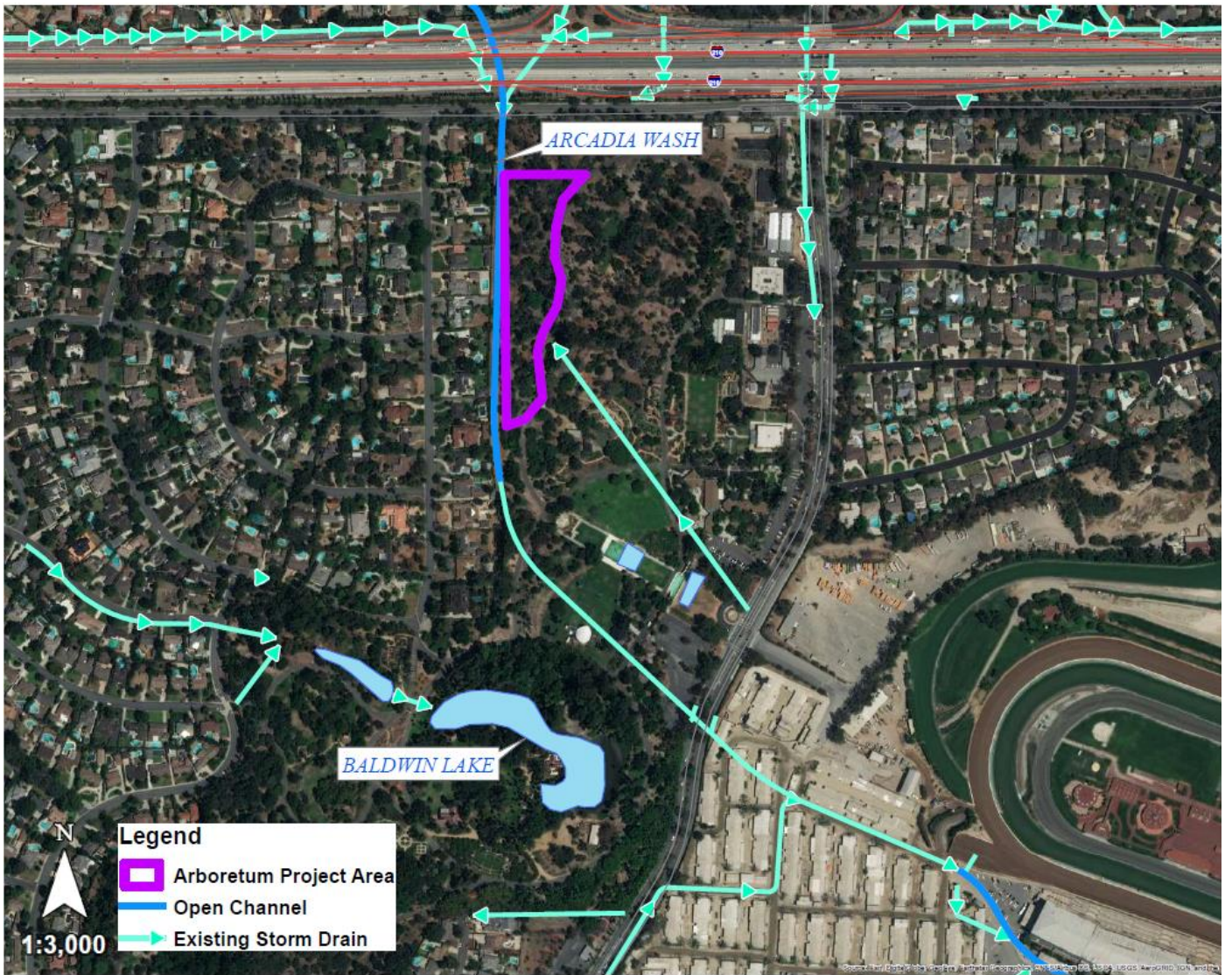
A brief overview of the existing site conditions for each regional BMP location as well as its drainage map can be found in the following sections. A full description and analysis of each individual site is included in its respective appendix section.

### 2.1.1 Arcadia Arboretum Natural Treatment and Groundwater Recharge Project

The Los Angeles Arboretum and Botanical Garden is located in the City of Arcadia, within a 1,633-acre watershed (**Figure 2**) which drains through the upstream storm drain system to Arcadia Wash then directly into the Rio Hondo Tributary. See **Figure 3** for an existing site conditions map.



**Figure 2.** Arcadia Wash Arboretum Natural Treatment and Groundwater Recharge Project Drainage Area and Location Map

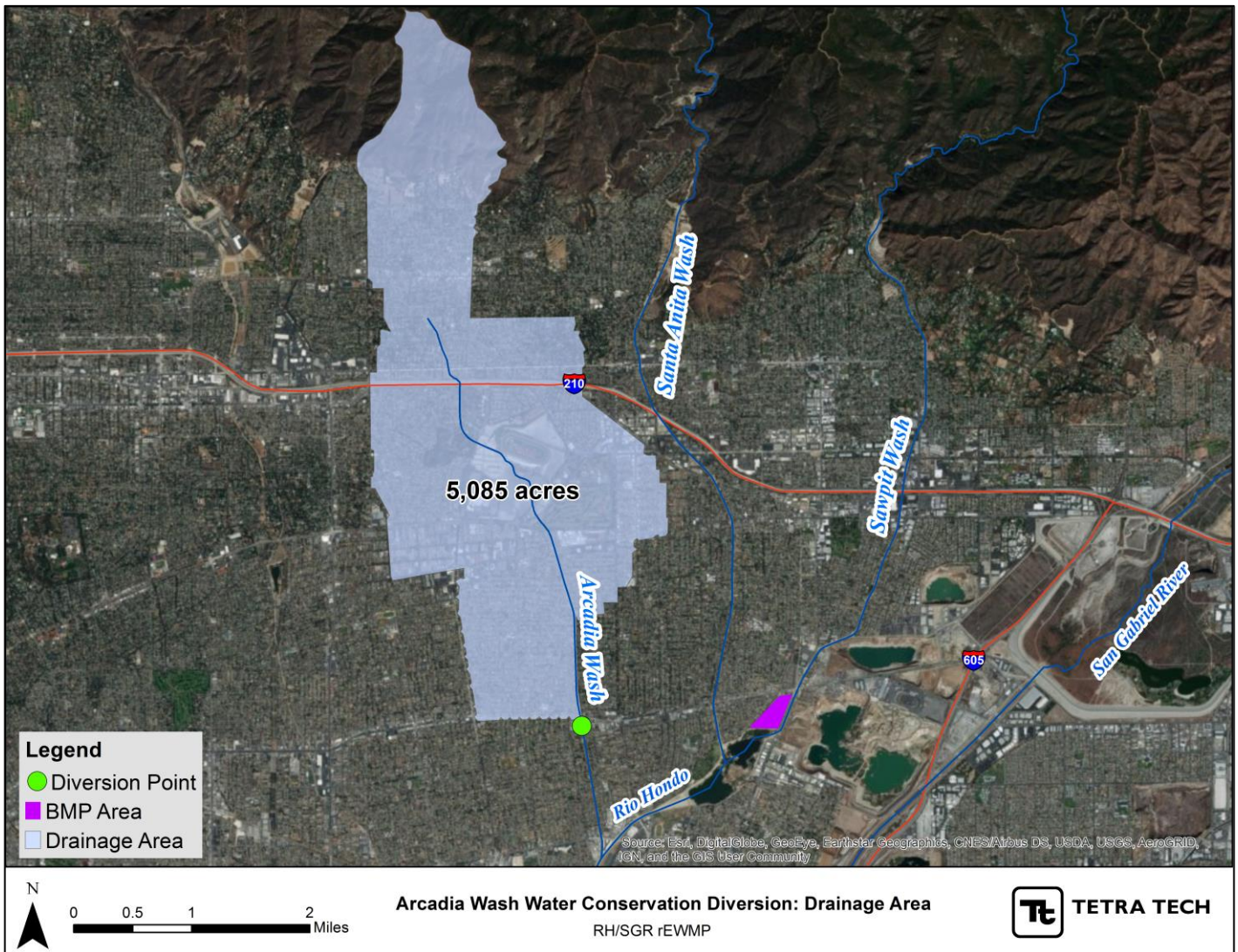


**Figure 3.** Arcadia Arboretum Natural Treatment and Groundwater Recharge Project Existing Conditions

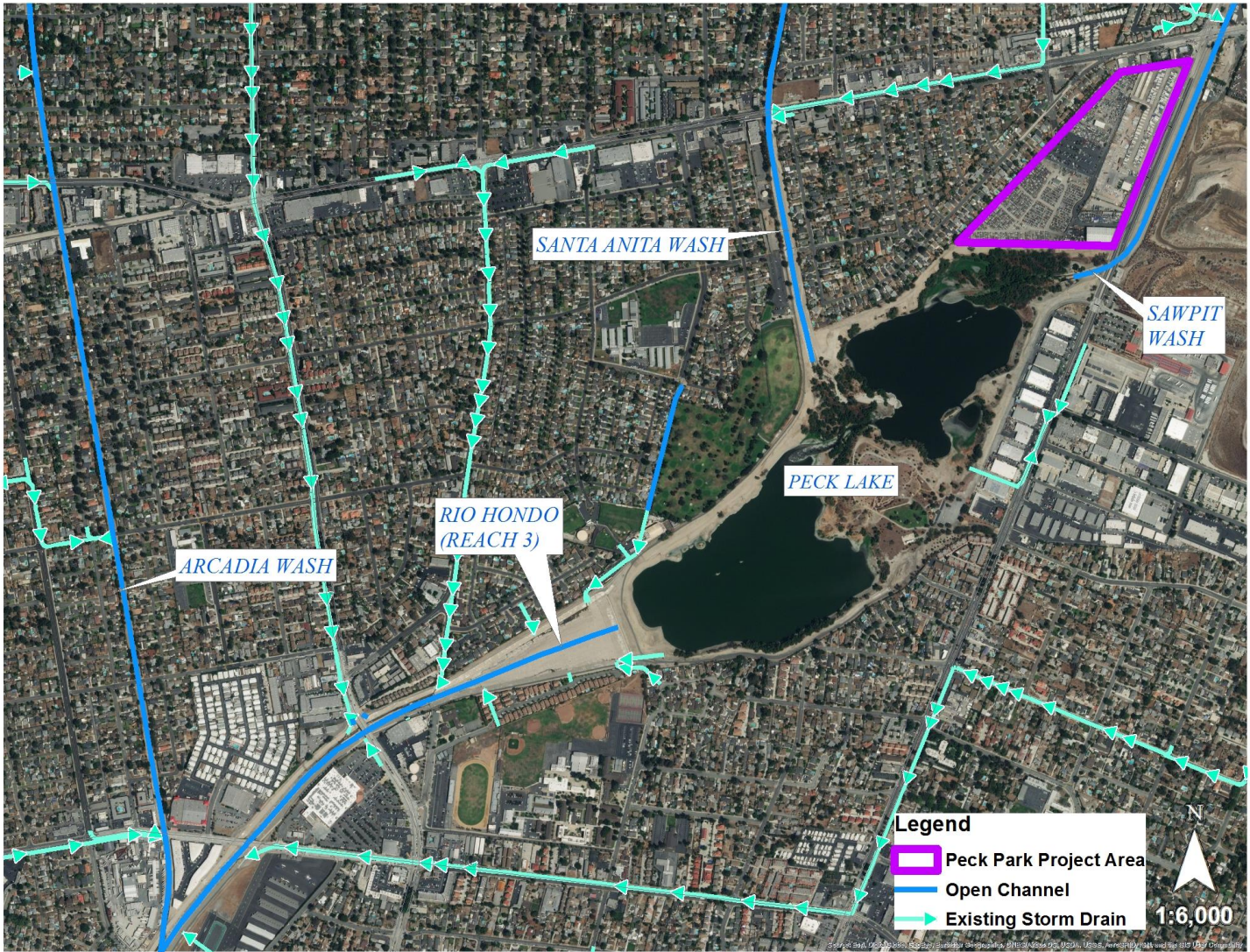
## 2.1.2 Rio Hondo Ecosystem Restoration Project and Arcadia Wash Water Conservation Diversion

### Phase 1

The Arcadia Wash Water Conservation Diversion Project is located in the City of Arcadia, within a 5,085-acre watershed (**Figure 4**), that drains water through the upstream storm drain system to Arcadia Wash. Arcadia drains directly into the Rio Hondo Tributary south of Peck Lake. See **Figure 5** for an existing site conditions map.



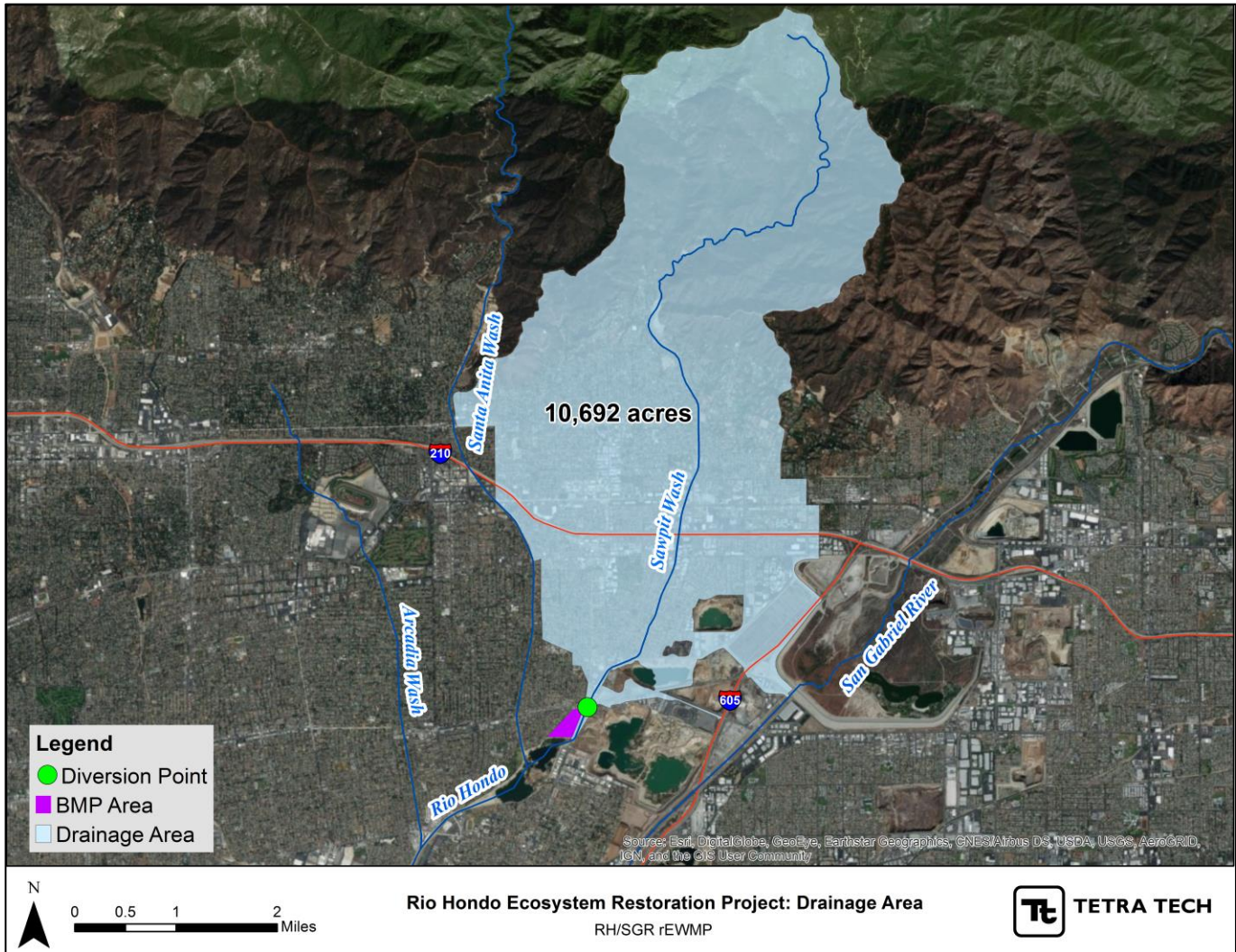
**Figure 4.** Arcadia Wash Water Conservation Diversion Drainage Area and Location Map



**Figure 5.** Arcadia Wash Existing Conditions Map

## Phase 2

The Rio Hondo Ecosystem Restoration Project is located in the southern portion of the cities of Arcadia and Monrovia, within a 10,692-acre watershed (**Figure 6**), which drains through the upstream storm drain system to Sawpit Wash. Sawpit Wash is a tributary to Peck Lake and the downstream Rio Hondo Tributary. See **Figure 7** for an existing site conditions map.



**Figure 6.** Rio Hondo Ecosystem Restoration Project Drainage Area and Location Map



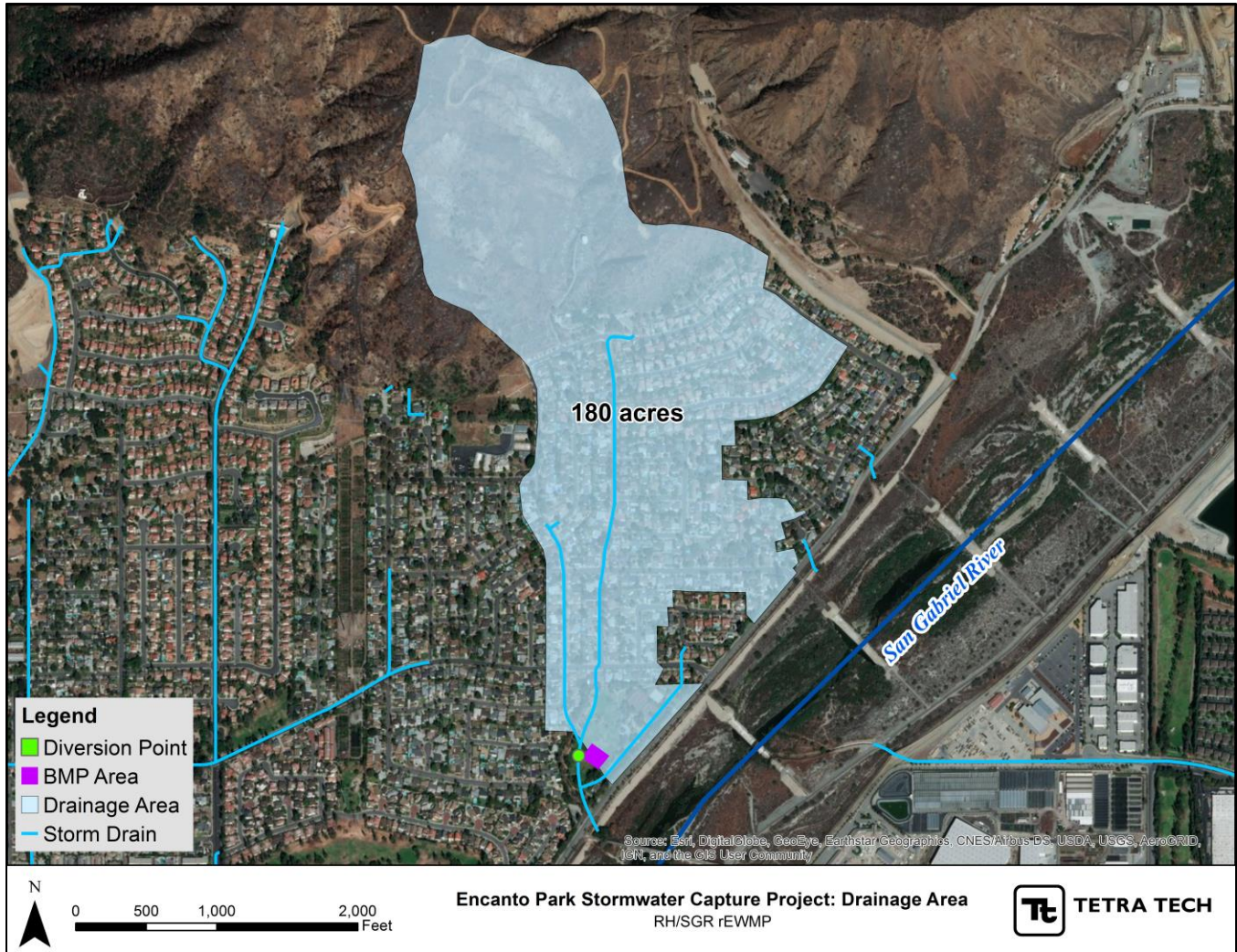
**Figure 7.** Rio Hondo Ecosystem Restoration Project Existing Site Conditions

### 2.1.2.2 Improvement Plans by Others

There are current improvement plans for a Clark Street Pump Station and Pipeline at the Peck Road Water Conservation Park by LA County Department of Public Works. These plans include construction of a pressurized pipe to pump water from residential and industrial properties east of Peck Road starting at Durfee Ave. This pipe will discharge flows to the Peck Road Water Conservation Park, therefore part of the construction plan is to dredge the existing basin near the Santa Anita Wash Outfall. Dredging efforts by others could benefit the feasibility of the Rio Hondo Ecosystem Restoration Project by increasing the capacity of the basin. An additional project is being proposed for sediment removal and construction of a pump station, pipeline, and outlet structure. The proposed pump station at Peck Road Spreading Basin would convey stored water to the San Gabriel River between the Santa Fe Dam Outlet and the 10 freeway, because there are higher infiltration rates in the San Gabriel River. The sediment removal efforts are focused on removing build-up at the outlet of Santa Anita Wash, which would allow the pump station to convey water from both basins at Peck Road.

### 2.1.3 Encanto Park Stormwater Capture Project

Encanto Park is located in the City of Duarte, within a 180-acre watershed (**Figure 8**), that drains through the upstream storm drain system directly into the San Gabriel River. See **Figure 9** below for an existing site conditions map.



**Figure 8.** Encanto Park Stormwater Capture Project Existing Site Conditions

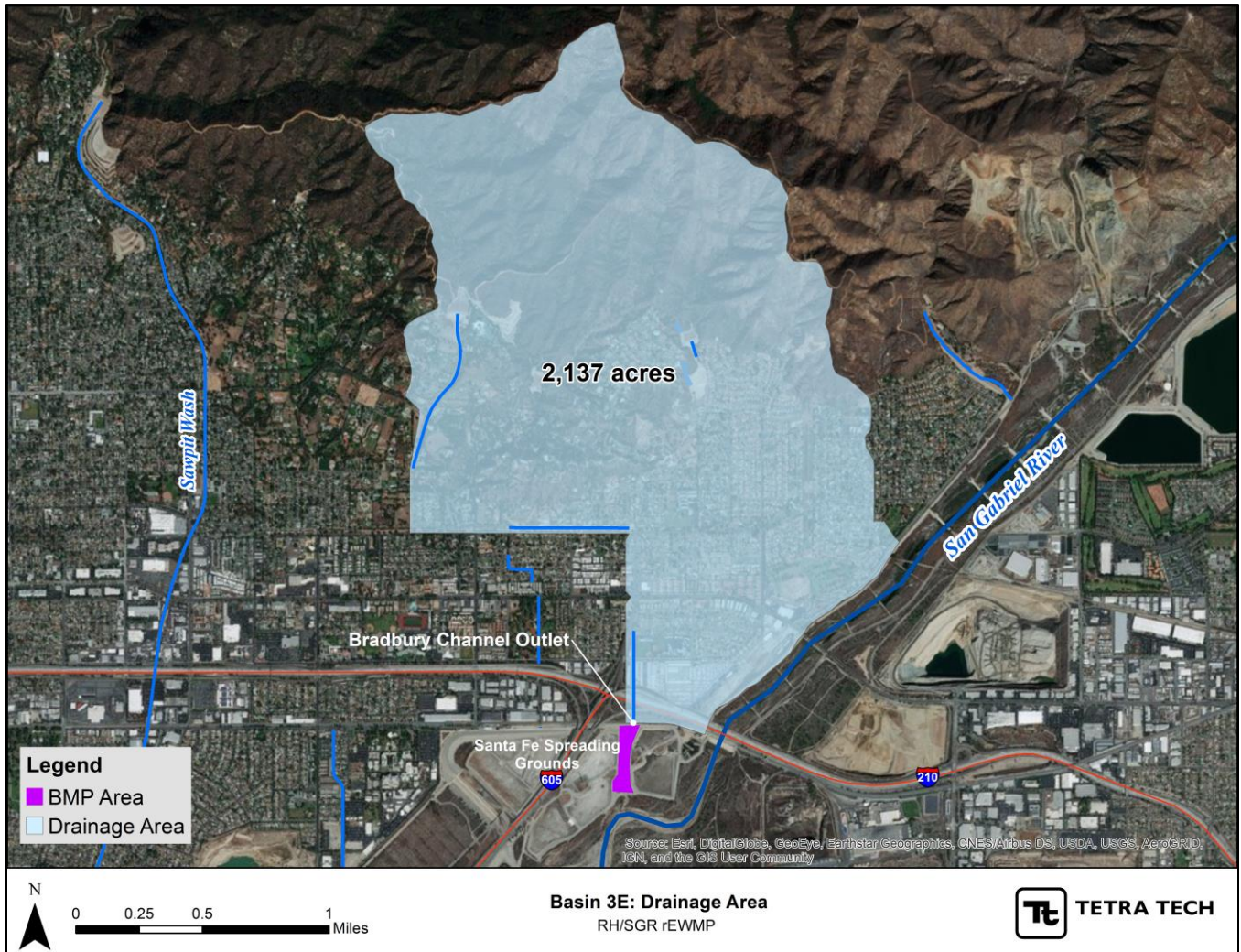


**Figure 9.** Encanto Park Existing Conditions Map

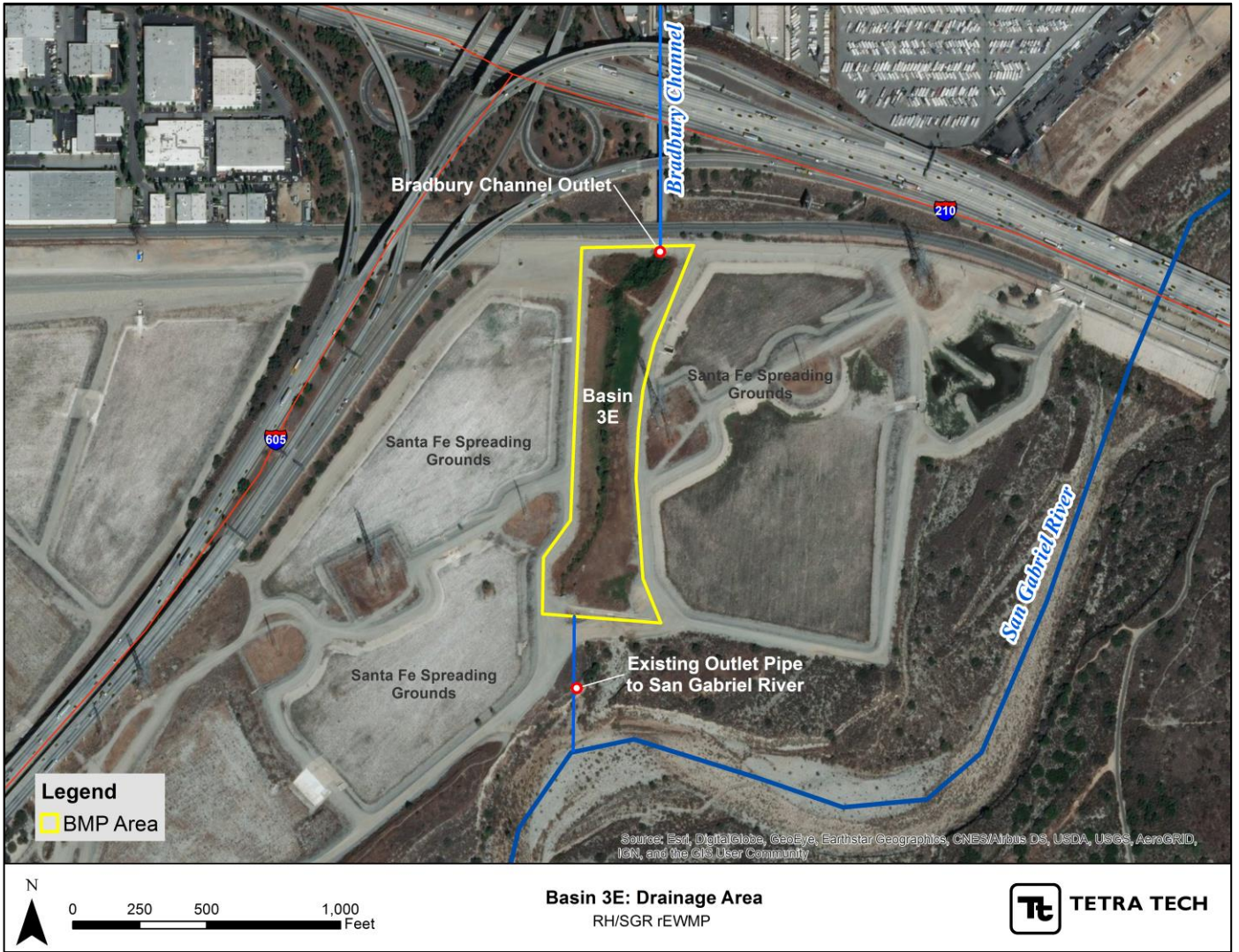


## 2.1.4 Basin 3E Enhancements at Santa Fe Spreading Grounds Project

Basin 3E is located at the Santa Fe Spreading Grounds, within a 2,137-acre watershed (**Figure 10**), which drains areas of Bradbury and Duarte through the upstream storm drain system to the San Gabriel River. See **Figure 11** below for an existing site conditions map.



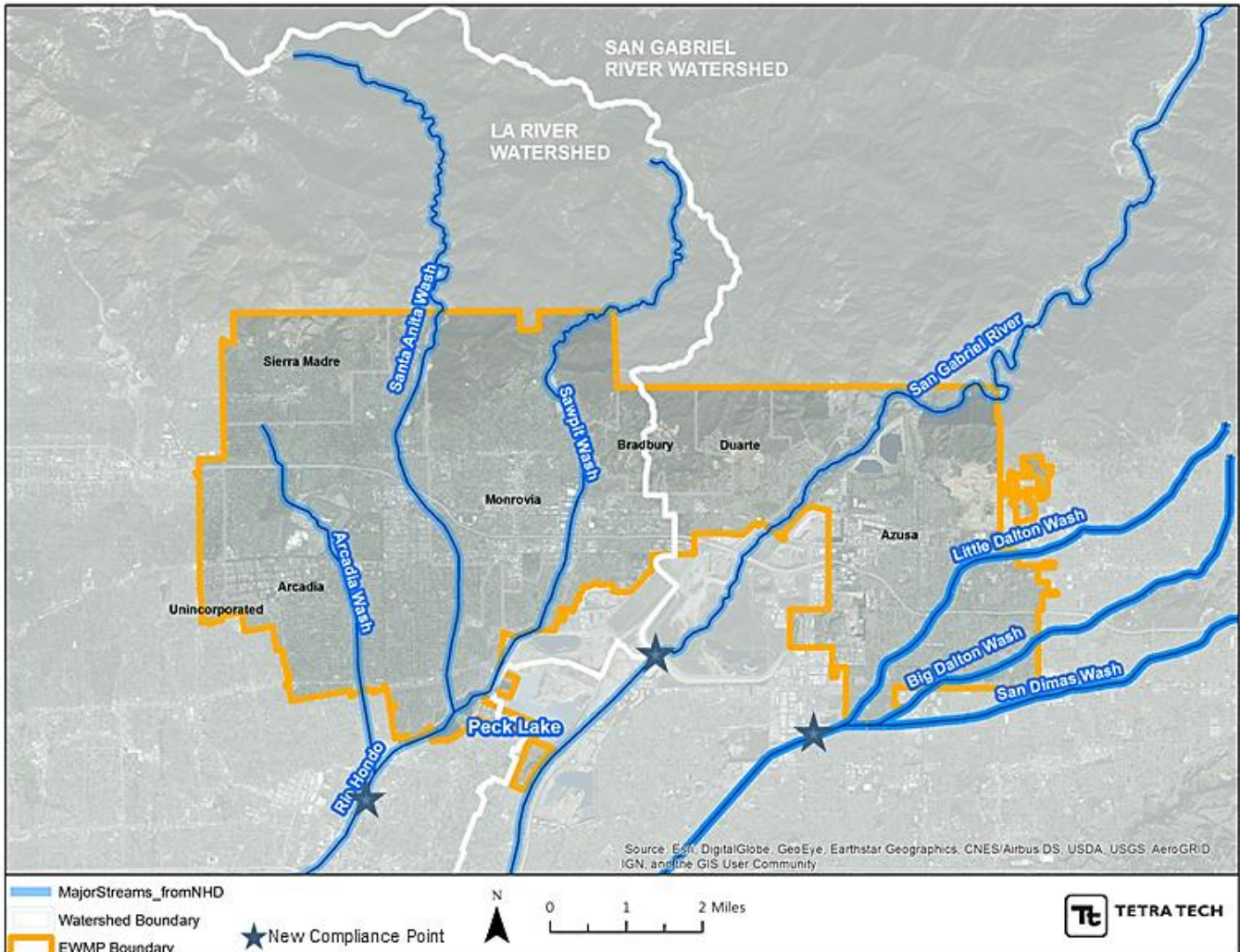
**Figure 10.** Basin 3E Drainage Area and Location Map



**Figure 11.** Basin 3E Enhancements at Santa Fe Spreading Grounds Existing Site Conditions

### 3.0 WATER QUALITY ANALYSIS

The water quality analysis was modeled for three compliance points, one at the downstream end of each of the tributary drainage areas. See **Figure 12** below for the compliance locations used in the water quality modeling. The revised analysis added a compliance point along the San Gabriel River, and moved the Big Dalton Wash compliance point downstream to account for the additional Little Dalton and San Dimas Wash tributary area. Loading Simulation Program in C++ (LSPC), which integrates GIS and Access, were utilized for this project. For a more detailed summary on the water quality modeling assumptions please refer to Attachment C. The following sections detail the steps taken to optimize the size of the recommended BMP.



**Figure 12.** Water Quality Compliance Points

### 3.1 DRAINAGE AREA DELINEATION

Drainage area delineation for Rio Hondo, the San Gabriel River, and Big Dalton Wash watershed was performed in ArcGIS using shapefiles from the LA County GIS portal. Drainage areas were refined for each regional project by using elevation data and the tributary storm drain pipes conveying flows within the watershed.

### 3.1.1 Rio Hondo Drainage

This watershed has a 31,344-acre drainage area. The rEWMP drainage area within the Rio Hondo Watershed is 15,870 acres. The Arcadia Arboretum Natural Treatment and Groundwater Recharge Project, the Rio Hondo Ecosystem Restoration Project, and the Arcadia Wash Water Conservation Diversion have drainage areas that tributary to the Rio Hondo.

### 3.1.2 San Gabriel River Drainage

The San Gabriel River drainage area starts in the hills of the San Gabriel Mountains, traveling downstream through urbanized city. This watershed drainage area delineated to 153,282 acres. The rEWMP drainage area within the Rio Hondo Watershed is 2,198 acres. The Encanto Park Stormwater Capture Project and the Basin 3E Enhancements at Santa Fe Spreading Grounds Project have drainage areas that are tributary to the San Gabriel River.

### 3.1.3 Big Dalton Wash Drainage

Big Dalton Wash drainage area runs through the eastern side of the EWMP boundary, and has a watershed area of 24,237 acres. This drainage area is mostly within the City of Azusa jurisdiction, with other areas of unincorporated county. As discussed in the revised RAA, the City of Azusa has opted to remove itself from the EWMP group and pursue other compliance measures. As such, there are no proposed regional BMPs diverting water from Big Dalton Wash. The rEWMP drainage area within the Big Dalton Wash watershed is 1,348 acres. The pollutant load reduction required by the analysis of this drainage area will be accounted for by other compliance measures such as green streets which have been analyzed herein.

### 3.1.4 Eaton Wash Drainage

A small portion of the western rEWMP drainage area drains west to Eaton Wash. The rEWMP drainage area tributary to the Eaton Wash watershed is 829 acres. The pollutant load reduction required by the analysis of this drainage area will be accounted for by other compliance measures such as green streets which have been analyzed herein.

## 3.2 OPTIMIZATION MODELING

---

For this study, the Los Angeles County Watershed Management Modeling System (WMMS) was used within the LSPC to simulate contaminant loading, runoff volume, and other baseline hydrology parameters. A more detailed description on the watershed modeling methodology and results that informed this feasibility study can be found in the revised Reasonable Assurance Analysis (RAA) in Attachment C of the rEWMP. The results from the revised RAA recommended using the critical water year as the critical condition for compliance, which was 2003 for the Rio Hondo. The limiting priority pollutant used in the water quality analysis based on the existing conditions was zinc.

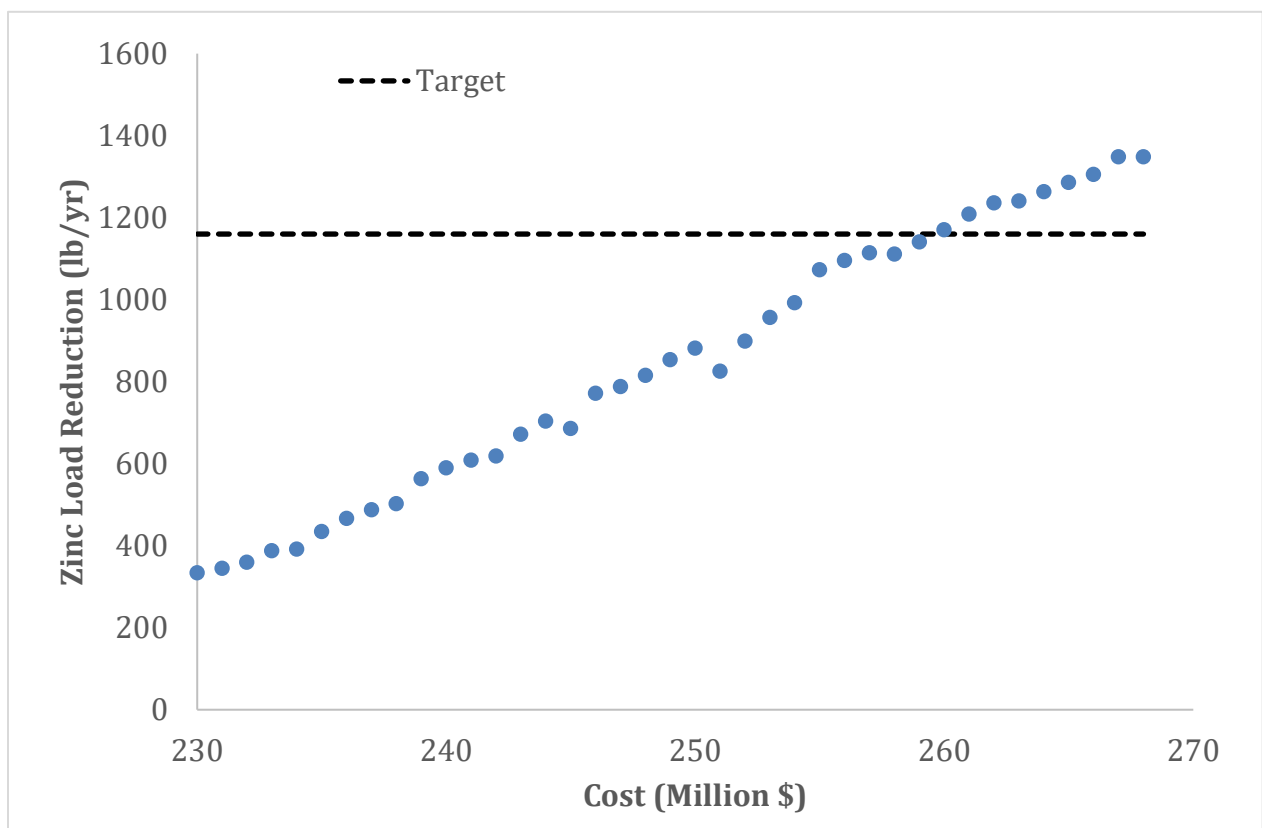
The optimum BMP footprint and diversion rate was determined for each BMP site based on the long-term average annual zinc reduction, simulated using the EPA System for Urban Stormwater Treatment and Analysis Integration (SUSTAIN) model. To optimize the selection and placement of BMPs, SUSTAIN iteratively runs different combinations of BMP properties, varied within a specified range, to generate a cost-effectiveness curve. These curves show the additional load reductions from potential multi-benefit regional project configurations, beyond that already achieved from redevelopment projects and MCMs. The recommended BMP sizes and diversion rates to BMPs are based on the most cost-effective scenario.

The annual critical condition for load reduction requirements was determined by comparing the average rainfall within a ten-year period (2002-2011) that was closest to the 90<sup>th</sup> percentile average rainfall. The runoff treated by the BMP was then simulated using the critical water year (determined for the Rio Hondo Watershed as 2003 and

the San Gabriel River Watershed as 2004). Configurations of the multi-benefit regional projects are discussed in the optimization results for the Rio Hondo and San Gabriel River. Since the BMP optimization for each watershed is based on all tributary BMPs, the achieved load reduction and cost presented are contingent upon implementing all projects for each watershed (i.e., project performance is interdependent because the BMPs are in a treatment train).

### 3.2.1 Rio Hondo Optimization Results

As discussed in the RAA, the cost-effectiveness curve allowed for the selection of the optimum configurations which achieve the numeric targets for pollutant load reduction. The curves show the additional load reductions from potential multi-benefit regional project configurations, beyond that already achieved from redevelopment projects and MCMs. The lower the slope of the curve, the less additional load reduction achieved at the same incremental increase to the cost. Configurations of the multi-benefit regional projects which meet the required load reductions and exhibit the maximum performance for the given cost were reviewed and the recommended configuration and associated cost-effectiveness curve are shown in **Figure 13** and **Table 2**.



**Figure 13.** Cost-Effectiveness Curve for Regional Projects within the Rio Hondo Drainage Area (note that modeled costs are relative – see engineering cost estimated in each appendix).

**Table 2.** Rio Hondo Regional BMP Optimization Results

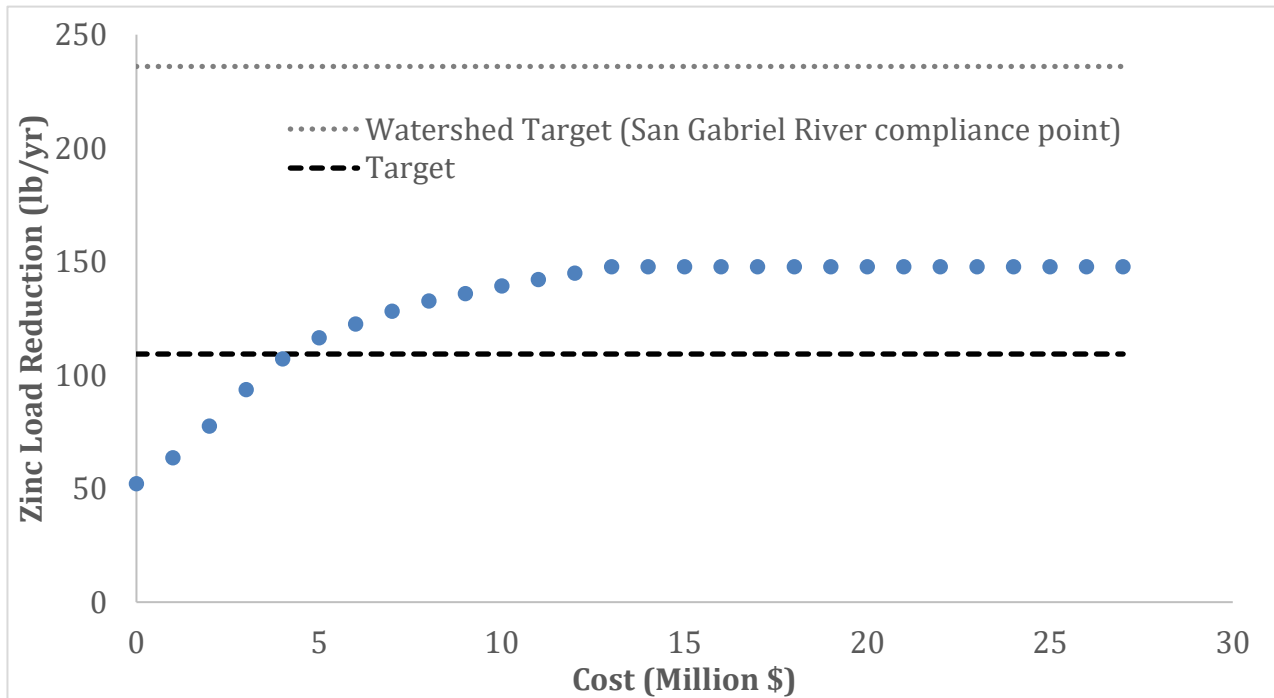
Parameter	Arboretum Wetland Pond	Arboretum Recharge Pond (each side) <sup>1</sup>	Rio Hondo Wetland
Length (feet)	500	500	2400
Width (feet)	50	30	150
Height (feet)	2.5	3	4
Diversion Rate (cfs)	30	N/A	185 (Sawpit Wash) + 37 (Arcadia Wash)
Load Reduction <sup>2</sup> (lb/yr)	854.0 (22.3%)		

**Notes:**

1. The concept layout has a wetland pond in the center, with a recharge pond on both sides of the wetland pond.
2. Existing Wet Days Zn Load for the Rio Hondo was 3,822 lbs/yr.

### 3.2.2 San Gabriel River Optimization

The same method of analyzing the cost-effectiveness curve and allowing that to guide the optimization parameters was complete for the San Gabriel River. A summary of results from the optimization analysis can be found in **Figure 14** and **Table 3** below.



**Figure 14.** Cost-Effectiveness Curve for Regional Projects within the San Gabriel River Drainage Area (note that modeled costs are relative – see engineering cost estimated in each appendix).

**Table 3.** San Gabriel River Regional BMP Optimization Results

Parameter	Encanto Underground Storage	Basin 3E Detention Basin
Length (feet)	75	550
Width (feet)	150	180
Height (feet)	5	5
Diversion Rate (cfs)	3	N/A
Load Reduction <sup>1</sup> (lb/yr)	64.3 (7.5%)	

**Note:**

1. Existing Wet Days Zn Load for the San Gabriel River was 852 lbs/yr.

### 3.2.3 Big Dalton Wash and Eaton Wash

No regional BMPs were evaluated for these areas. Distributed green infrastructure is required to meet the required load reductions for Big Dalton Wash (BDW) and Eaton Wash (EW). An initial screening of potential green street opportunities was completed for the County of Los Angeles area within the BDW and EW drainage areas. Using the same optimization modeling many configurations were identified, varying the length of potential green street opportunities. In **Table 4** below is a summary of the green streets parameters required to meet the LA County required load reduction. Because the City of Azusa is no longer pursuing compliance measures with the EWMP group, LA County area is the only jurisdiction within EWMP boundary tributary to Big Dalton Wash. Please see the Revised RAA in Attachment C for further details. In addition, a Fact Sheet has been created to give general details about potential green infrastructure concepts and locations that might be feasible within the EWMP boundary. This Fact Sheet can be found in Appendix B.5.

**Table 4.** Green Streets Summary

	Total Footprint (acres)	Total Length* (miles)	Cost, Including 20 Year O&M (Million \$)	Load Reduction (lb/yr)	Treated Drainage Area (acres)
<b>Big Dalton Wash</b>	3.8	7.8	11.4	54.7 (3.7%)	674.7
<b>Eaton Wash</b>	5.2	10.7	15.8	59.5 (18.4%)	326.6

\*Note: Assumed 4' width.

## 4.0 PROPOSED CONCEPTS

The proposed concepts were developed to address the pollutant load reduction required in the most efficient manner. By taking into consideration the tradeoff between cost and pollutant removal within the watershed based on the optimization, the individual sizing for each BMP was then determined. Within the appendix for each regional BMP, the follow parameters are discussed in detail:

1. Site Layout
2. Pretreatment Method
3. BMP Components and Benefits

## 4.1 ARCADIA ARBORETUM NATURAL TREATMENT AND GROUNDWATER RECHARGE PROJECT

The regional BMP system will divert runoff from Arcadia Wash to a sediment forebay for pretreatment, with flows then entering a wetland surrounded by two groundwater recharge ponds. This system will have a controlled outlet with pump station to convey up to 1 cfs of treated water through a meandering stream to Baldwin Lake. The site layout is provided in **Figure 15**. A rendering show in **Figure 16** has also been created to give a conceptual picture of what the constructed wet and dry ponds could look like when full. The preliminary construction cost estimated for this project is \$5,893,433. Additional project details including the site layout, project fact sheet, and detailed cost estimated can be found in Appendix 2.1 of this study.



**Figure 15.** Site Layout for Arcadia Arboretum Natural Treatment and Groundwater Recharge Project





**Figure 16.** Rendering of the Arboretum Wet and Dry Ponds in Wet Weather

### 4.1.1 Potential Constraints

One of the constraints in designing this BMP is the large amount of excavation required. To keep diversion costs lower and to simplify the system, it would be ideal for the diversion to be gravity fed. To accomplish that, the existing land would need 10 feet to 15 feet of excavation. Arcadia Wash is approximately 13 feet below the existing grade at the Arboretum, and even with the amount of ponding generated from the inflatable rubber dam it would require significant excavation. Excavation and hauling dirt can be costly measures.

Another constraint is the dry weather flow that is present in Arcadia Wash. There needs to be enough dry weather flow to sustain the wetlands, while also allowing for a 1 cfs steady discharge to Baldwin Lake for sustainability. If dry weather flow is insufficient, then Baldwin Lake may not improve in condition. The use of gates between the sediment basin and the wetland/recharge ponds will aide in this constraint by allowing the flows to be contained first to the wetlands to sustain plant life, and second to the recharge ponds to benefit the groundwater basin.

## 4.2 RIO HONDO ECOSYSTEM RESTORATION PROJECT AND ARCADIA WASH WATER CONSERVATION DIVERSION

The concept for the Rio Hondo Ecosystem Restoration stormwater BMP and Arcadia Wash Water Conservation Diversion is split into two phases. These phases are discussed below.

### 4.2.1 Phase 1 – Arcadia Wash Water Conservation Diversion

Phase 1 of this Regional BMP System will focus on water conservation efforts for Arcadia Wash to recharge water into the San Gabriel Groundwater Basin. This phase will not only provide water conservation benefits by recharging flow from Arcadia Wash, but will also provide incidental water quality benefits to help meet the 50% milestone for the LA River Metals TMDL. Phase 1 of this project is primarily a water conservation project, and is considered an update to the baseline watershed model rather than a water quality BMP.

Runoff from Arcadia Wash will be diverted to a pretreatment device at the intersection of Live Oak Avenue and conveyed approximately 10,000 to the east to Sawpit Wash. The flows will be conveyed via gravity until passing Santa Anita Wash, at which point a pump station will be used to lift the flows for continued gravity flow to Sawpit Wash. See **Figure 17** for the Phase 1 site layout.



**Figure 17.** Phase 1 Site Layout – Arcadia Wash Water Conservation Diversion

## 4.2.2 Phase 2 – Rio Hondo Ecosystem Restoration Project

Phase 2 of this project is where the majority of the regional water quality benefits will be achieved. This phase combines the water conservation benefits from Phase 1 with the additional pollutant load reduction and habitat restoration benefits provided by a constructed wetland. This project will also provide a natural treatment system to the downstream spreading basin at Peck Park. A temporary inundation area adjacent to the wetland will allow for groundwater recharge as well.

Phase 2 of this project will divert runoff from Sawpit Wash (and the Phase 1 Arcadia wash flows) to convey stormwater flows to a sediment basin before entering an 8.3-acre constructed wetlands habitat with adjacent groundwater recharge basins prior to discharge into the Peck Road Water Conservation basins and to the downstream Rio Hondo Channel. See **Figure 18** for the Phase 2 site layout.



**Figure 18.** Phase 2 – Rio Hondo Ecosystem Restoration Project

#### **4.2.4 Potential Constraints**

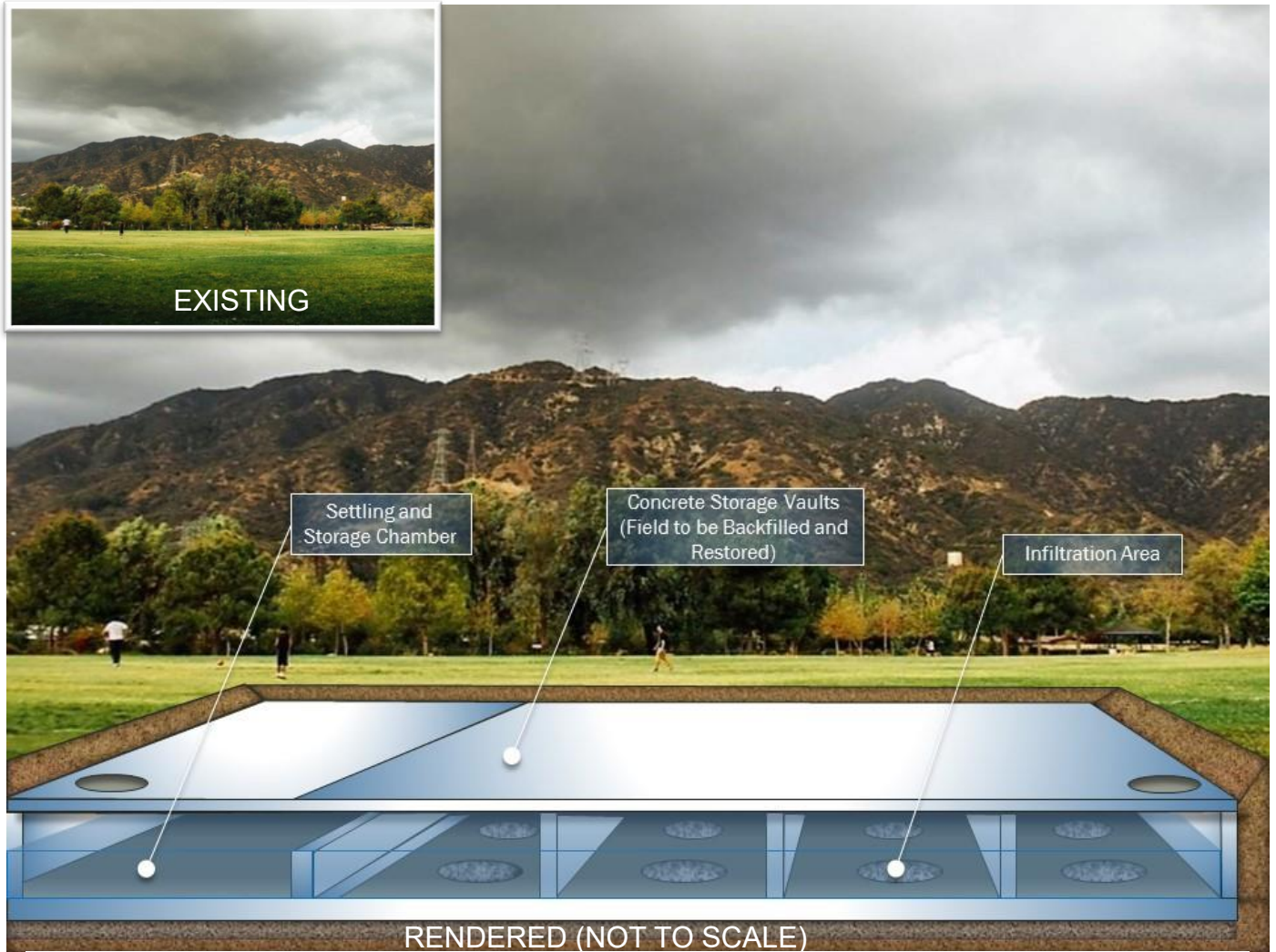
One constraint for this BMP project would be the time and money needed to acquire the 24-acre piece of commercial land that is owned by various private businesses. Acquisition could cause delays in the design and construction process, which leads to an unknown timeline. Additionally, based on the desktop investigation on preliminary infiltration feasibility (Exhibit B.2.3 of Appendix B.2), the soils may be subject to liquefaction, which will not affect the infiltration capabilities, but the appropriate setbacks will need to be met for constructing near the surrounding houses to ensure no potential damage to their foundations. This constraint will not hinder the overall feasibility of the project, but a consideration for the design and construction phases.

### 4.3 ENCANTO PARK STORMWATER CAPTURE PROJECT

The regional BMP system will divert runoff from the existing 72-inch RCP LACFCD storm drain within a concrete diversion structure, into an 18-inch diameter pipe, from the storm drain to a pretreatment device. Flows from the pretreatment device will enter and underground infiltration gallery via gravity. The site layout is provided in **Figure 19**. A rendering show in **Figure 20** has also been created to give a conceptual picture of what the subsurface structure will look like beneath Encanto Park.



Figure 19. Encanto Park Stormwater Capture Project Site Layout



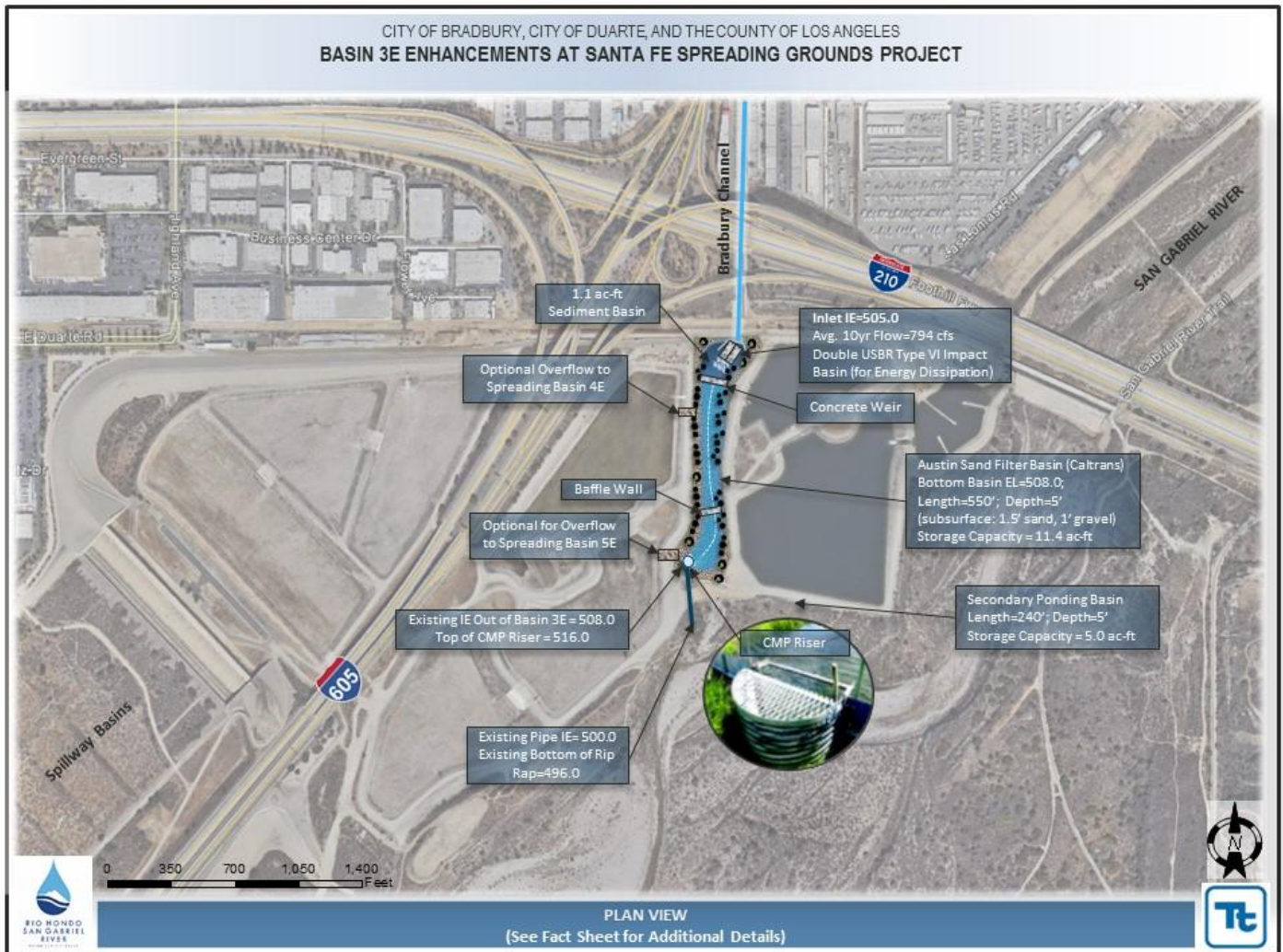
**Figure 20.** Rendering of Proposed Subsurface Structure at Encanto Park

### 4.3.1 Potential Constraints

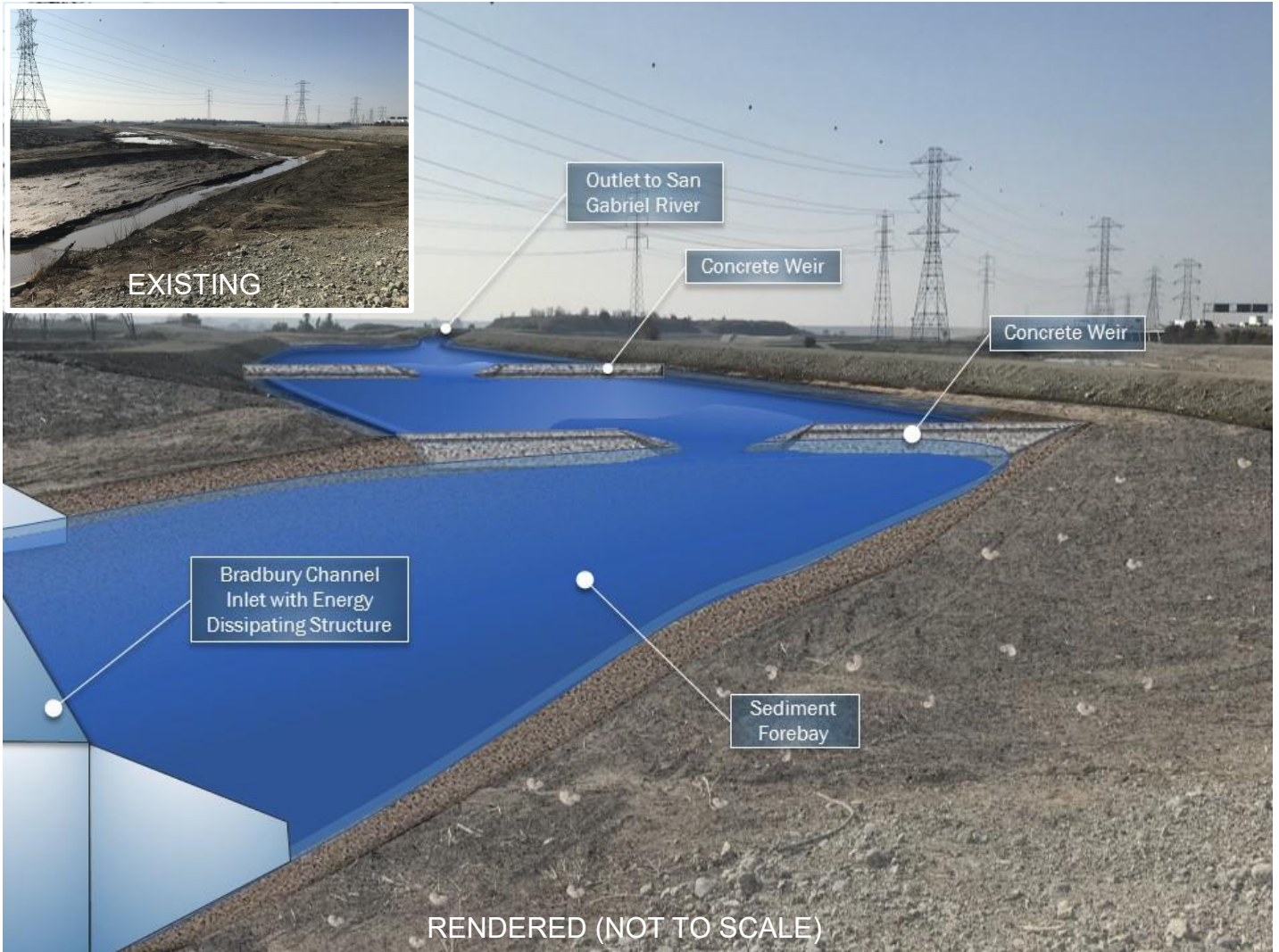
The Encanto Park project does not initially pose any major constraints. Due to its close proximity to the San Gabriel River, infiltration rates should be high. As is the case with the construction of any stormwater device planned underneath a park, there will be a season of construction which will leave the field of the park unusable. This will place a temporary hold on any sports leagues, planned community events, etc. that would typically take place there. A contingency plan would need to be put in place to temporarily relocate any activities until construction were complete.

## 4.4 BASIN 3E ENHANCEMENTS AT SANTA FE SPREADING GROUNDS PROJECT

The regional BMP system will enhance the existing flood control detention basin at the Santa Fe Spreading Grounds (SFSG) by constructing a sediment forebay with an energy dissipating mechanism for pretreatment. Flows from the sediment basin will spill over a concrete weir to a secondary basin where water will be filtered through a sand filter media with a geotextile bottom and perforated underdrains to convey treated flows to the San Gabriel River. There will be a second concrete weir with overflow that will drain into a smaller basin that will provide additional treatment as well as utilize the downstream portion of the basin that is not needed for the water quality sizing. The site layout is provided in **Figure 21**. A rendering show in **Figure 22** has also been created to give a conceptual picture of what the Basin 3E enhancements would look like.



**Figure 21.** Basin 3E Enhancements at Santa Fe Spreading Grounds Site Layout

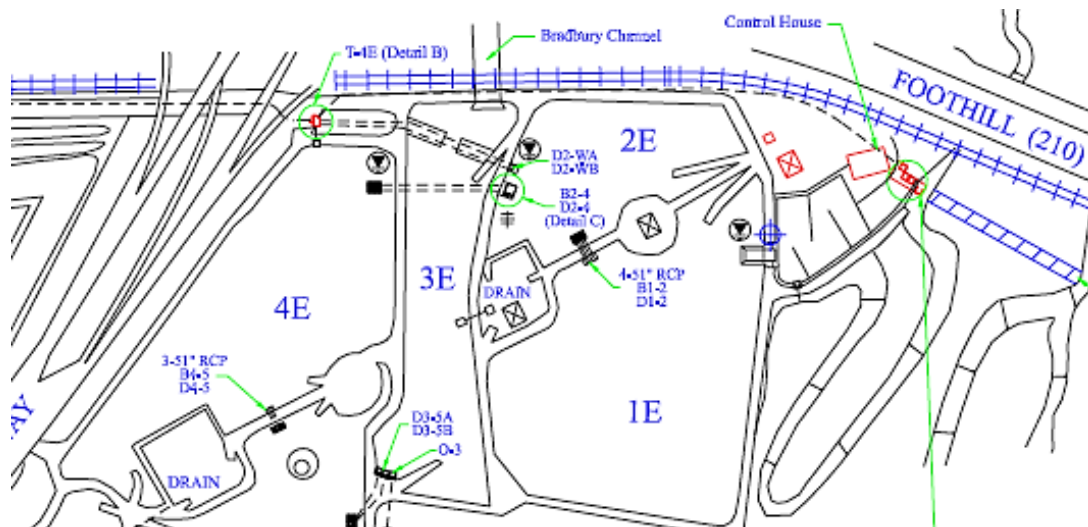


**Figure 22.** Rendering of Proposed Basin 3E Enhancements

#### 4.4.2 Potential Constraints

Basin 3E is constrained by its size. It is currently surrounded by the Santa Fe Spreading Grounds as shown in **Figure 23**. Keeping the side slopes within the allowable 3:1 maximum will constrain the amount of additional depth that can be gained in the basin. An additional constraint for this project would be funding. The spreading grounds are located on property owned by the US Army Corps of Engineers and operated by the Los Angeles County Flood Control District. Due to this, no recreational use can be pursued, which may limit the funding that would be available for this type of retrofit of an existing facility.





**Figure 23.** Santa Fe Spreading Grounds Adjacent to Basin 3E Schematic

## 5.0 LONG TERM MONITORING

The installation of a permanent monitoring system at each project site will include equipment that measures flow and water quality in both dry and wet seasons. The monitoring system will afford the RH/SGR WQG the ability to measure the effectiveness of the regional structural BMPs to infiltrate diverted flows and remove pollutants. Additionally, a permanent monitoring system will provide project performance data useful for adaptive management and sustained achievement of project performance goals. The monitoring plan includes collecting water quality samples at the inlet and outlet of each BMP to measure water quality improvement and ensure compliance. Additional monitoring equipment, including water level meters and soil moisture sensors are recommended to monitor and track the long-term performance of the regional structural BMPs. A continuous monitoring system can provide significant insight into the current and long-term performance of the BMPs. A water level logger at the surface of the soil media can collect data on the ponding depth and ultimately determine the infiltration rate at the surface. This data can be used to determine the performance throughout a rain event and demonstrate any decreases in performance from the start of the rain event to the end; an overall reduction in infiltration could indicate an impending maintenance need allowing staff to predict when maintenance will be required rather than reacting to a visual indicator. A soil moisture sensor strategically placed in the BMP could also indicate if the system is performing as designed and identify any potential performance limitations.

## 6.0 SCHEDULE AND COST ESTIMATES

The cost estimates and project schedule have been created to validate that the preliminary designs for each proposed BMP site may be built within the specified budget and within the time allocated to use the funds.

### 6.1 PROJECT SCHEDULE

A timeline for implementation of each regional structural BMP site has been estimated based on all the projects being implemented at the same time. Depending on the RH/SGR WQG's available funds and project preference, this timeline can be shifted for each project by changing the dates and keeping the working days the same and meeting the EWMP milestone deadlines. A detailed schedule estimate is provided in each appendix, and a summary is provided in **Table 5**.

**Table 5.** Project Schedule Summary

Regional BMP Site	Phase 1		Phase 2	
	Start	Finish	Start	Finish
Arcadia Arboretum Natural Treatment and Groundwater Recharge Project	1/11/2018	1/11/2028	-	-
Rio Hondo Ecosystem Restoration Project and Arcadia Wash Water Conservation Diversion	1/11/2021	1/11/2024	7/11/2023	1/11/2028
Encanto Park Stormwater Capture Project	9/30/2022	9/30/2026	-	-
Basin 3E Enhancements at Santa Fe Spreading Grounds Project	3/30/2019	9/30/2023	3/30/2019	9/30/2026

## 6.2 CONSTRUCTION COST

The construction costs associated with each concept entail various components of the projects that a Contractor would construct for the City. Construction costs do not include items of work not directly performed by the Contractor, such as a City’s construction management during construction. The construction costs were developed using various source of cost information. Unit costs were based on Caltrans historical data and RSMMeans cost data. All costs were approximately adjusted to 2018 dollars based respectively on the Caltrans Construction Cost Index and RSMMeans Historical Cost Index. The estimated capital construction costs for the proposed BMPs are listed in **Table 6**. Detailed cost estimates are included in each Appendix.

**Table 6.** Estimated Capital Construction Costs for Proposed BMP Sites

Regional BMP Site	Estimated Capital Construction Cost
Acadia Arboretum Natural Treatment and Groundwater Recharge Project	\$5,893,433
Rio Hondo Ecosystem Restoration Project and Arcadia Wash Water Conservation Diversion	Phase 1 - \$9,382,125; Phase 2 - \$48,562,020 Total - \$57,944,145
Encanto Park Stormwater Capture Project	\$1,779,388
Basin 3E Enhancements at Santa Fe Spreading Grounds Project	\$2,078,718
<b>Total</b>	<b>\$67,695,684</b>

## 6.3 PROJECT IMPLEMENTATION COSTS

Project implementation costs include all the necessary items to provide a finished product. Costs include predesign, design, construction, construction management, and post construction work. The estimated project delivery costs for predesign, design, and construction management are based on a percentage of the construction costs. Their typical breakdown is provided below in **Table 7**. The full project costs of each project are included in their respective Appendix. A summary table is provided in **Table 8** for total project costs.

**Table 7.** Project Delivery Costs

Item Description	Percentage of Construction Costs
Feasibility Study	15%
Design	1.5%
Environmental Documentation and Permitting	1%
Construction Administration	10%

**Table 8.** Total Project Implementation Costs Summarized

Regional BMP Site	Construction Costs	Project Delivery Costs	Total Implementation Costs
Acadia Arboretum Natural Treatment and Groundwater Recharge Project	\$5,893,433	\$2,445,772	\$8,339,205
Rio Hondo Ecosystem Restoration Project and Arcadia Wash Water Conservation Diversion	\$57,944,145	\$22,888,496	\$80,832,641
Encanto Park Stormwater Capture Project	\$1,779,388	\$702,864	\$2,482,252
Basin 3E Enhancements at Santa Fe Spreading Grounds Project	\$2,078,718	\$821,107	\$2,899,825
		<b>TOTAL</b>	<b>\$94,553,923</b>

## 6.4 OPERATIONS AND MAINTENANCE COSTS

The operations and maintenance cost estimates were developed on the basis that a service contractor would maintain the various components of the system. Operation of the system during wet weather and dry weather events will be managed by the City/County. Operations of the diversion structure will incorporate coordination and notifications to the LACFCD to ensure that there will be no effect to the flood control conveyance system operation. The operation and maintenance costs for each site vary depending on the design components involved. A detailed table with annual estimated operation and maintenance activities and associated costs are provided in each appendix.

## 7.0 REGULATORY AND PERMITTING EVALUATION

Consultation with regulatory agencies and acquisition of permits is required before the project components can be constructed. The following sections summarize regulatory permits and approvals relevant to the RH/SGR rEWMP projects.

## 7.1 REGIONAL WATER QUALITY CONTROL BOARD, LOS ANGELES REGION (NPDES PERMIT NO. CAS004001)

---

On November 8, 2012, the Los Angeles Regional Water Quality Control Board adopted the Los Angeles County National Pollutant Discharge Elimination System (NPDES) Municipal Separate Storm Sewer System (MS4) Permit (Order No. R4-2012-0175, NPDES No. CAS00904001) for municipal stormwater and urban runoff discharges within the County of Los Angeles. The permit was issued to the LACFCD, the County of Los Angeles, and 84 incorporated cities within the coastal watersheds of Los Angeles County (with the exception of the City of Long Beach).

In compliance with the Los Angeles County NPDES MS4 Permit (Order No. R4-2012-0175), the RH/SGR WQG developed an EWMP to address water quality priorities by completing a comprehensive stormwater management plan that optimizes pollutant reduction and financial resources. In response to an error found in the EWMP RAA, a revised EWMP was developed to accurately assess and address the priority pollutants and determine a plan for implementation of enhanced MCMs, redevelopment LIDs, green streets, and multi-benefit regional projects.

## 7.2 SOUTH COAST AIR QUALITY MANAGEMENT DISTRICT

---

Construction activities in the South Coast Air Basin are subject to South Coast Air Quality Management District's (SCAQMD) Rule 403. Rule 403 sets requirements to regulate operations, which periodically may cause fugitive dust emissions into the atmosphere by requiring actions to prevent, reduce, or mitigate fugitive dust emissions.

All construction in the South Coast Air Basin must incorporate best available control measures (BACT) included in Table 1 of Rule 403. Additionally, large operations (defined as active operations on 50 acres or more), or projects with daily earth-moving or throughput volume of 3,850 cubic meters or more, three times during the most recent 365-day period, are further required to submit a large operation notification, identify a certified dust control supervisor, implement measures from Tables 2 and 3 of Rule 403, and maintain daily records.

## 7.3 LOS ANGELES COUNTY FLOOD CONTROL DISTRICT

---

The LACFCD is responsible for managing flood risk and conserving stormwater for groundwater recharge. The LACFCD system also provides control of debris, collection of surface stormwater from streets, and replenishes groundwater with stormwater and imported and recycled waters. The LACFCD covers the 2,753 square-mile portion of Los Angeles County south of the east-west projection of Avenue S, excluding Catalina Island. It is a special district governed by the County of Los Angeles Board of Supervisors, and its functions are carried out by the Los Angeles County Department of Public Works.

In order to continue to fulfill these responsibilities and maintain the existing level of service, any proposed construction within the LACFCD right-of-way requires approval from the LACFCD. Coordination with the Los Angeles County Department of Public Works staff, who act also on behalf of the LACFCD, will be critical in the development of this project.

The following describes the potential approval requirements from the LACFCD.

**Flood Control Permit** - A Flood Control Permit is required to ensure that a proposed use does not interfere with the LACFCD's operation and maintenance responsibilities. The following activities would require a Flood Control Permit:

- New Flood Control or Water Conservation Facility Construction
- Modifications to Existing Facilities
- BMP Installation for Water Quality Improvements

**Use or Maintenance Agreement** - However, depending on the scope, timeframe, and/or perpetual maintenance requirements of the proposed activity, the LACFCD may also require the project proponent to enter into a use or

maintenance agreement. If the LACFCD has fee ownership, then the LACFCD is the sole owner of the land. If LACFCD only has easement rights, the project proponent will be conditioned to obtain permission from the underlying fee owner before start of work.

## **7.4 US ARMY CORPS OF ENGINEERS (USACE) SECTION 408 PERMIT**

---

The Civil Works program by the USACE serves to provide the nation with quality and responsive management of the Nation's water resources. For other agencies/jurisdictions that may need to alter a Civil Works Program project and their associated lands, a Section 408 Permit is required. The USACE Section 408 Permit was created to ensure that these projects continue to provide their intended benefits to the public. Improvements or alterations to these projects are subject to the approval of USACE.

## **7.5 CEQA/NEPA**

---

Compliance with the California Environmental Quality Act (CEQA) would be required. A governmental agency is required to comply with CEQA procedures when the agency proposes to carry out or approve the activity/project. CEQA considers a "project" to be the whole of an action, which has a potential for resulting in either a direct physical change in the environment, or a reasonably foreseeable indirect physical change in the environment. The preparation of an Initial Study (IS) is typically the first step for projects determined not to be exempt from CEQA requirements. Initial Studies allow decision-makers the opportunity to review a proposed project and to make an environmental determination recommending the follow-on CEQA document. Initial Studies consider all phases of project planning, implementation, and operation and utilize the CEQA Guidelines IS Checklist form that covers 17 environmental resources topics. If the IS identifies that there is no substantial evidence that the project may have a significant impact on the environment (without or with mitigation) then a Negative Declaration or Mitigated Negative Declaration may be prepared. In the unlikely event that the IS identifies that the project may have a significant impact on the environment, then an Environmental Impact Report (EIR) is prepared. A description of investigations that may be required are included below.

Compliance with the National Environmental Policy Act (NEPA) would be required if there is a federal nexus (such as federal funding) and would need to comply with the implementing procedures of the applicable federal agency.

### **7.5.1 Historical Resources**

The Historical Resources assessment will investigate the occurrence of historically significant areas within the vicinity of a proposed project site, namely sites listed on or eligible for designation by the California Register of Historical Resources (CRHR). A resource should be considered a historical resource if it has previously been identified as significant in a historical resources survey.

If a Lead Agency is unsure about a resource, they should consider hiring a professional historian or archeologist who meets the Secretary of the Interior Standards Professional Qualifications for History, Architectural History, or Archeology. However, CEQA ultimately delegates final authority to the Lead Agency to determine if a resource is historically significant or not (CEQA Case Studies).

Similar projects within recent years to the submission of this report have identified historical wheat farms from the 1870s and shipper centers from the 1920s, which had no official historical designations.

### **7.5.2 Archaeological Resources**

Investigations by institutions such as The Native American Heritage Commission's search of the Sacred Lands Inventory will likely be required for full compliance. Further assessments for isolated artifacts or stream or topographical formations may also indicate the presence of subsurface prehistoric archaeological resources during excavation.

### 7.5.3 Paleontological Resources

Paleontological records may be assessed for records of known vertebrate fossils within the proposed project areas, as well as within older, sedimentary deposits.

### 7.5.4 Burial Sites

An investigation of known burial sites will occur prior to construction. In the event that an unknown burial site or human remains are found during excavation, mitigation should be implemented so that potential impacts remain at a less than significant level.

## 7.6 LOCAL PERMITS

Each city where the project is constructed may require building and grading permits. Traffic control will play an integral role during the trenching activities for the storm drains and discharge lines as well as the hauling of export from the project during the excavation phase of the project.

## 8.0 CONCLUSION AND RECOMMENDATIONS

The proposed stormwater BMPs have been developed to address the water quality objectives of the revised RAA for the RH/SGR EWMP, while taking into consideration the most cost-effective way to achieve regional benefit. While regional projects provide a more efficient way to achieve water quality goals, not all targets can be met by the proposed regional BMPs. As such, green streets are also recommended as a compliance measure to meet the pollutant reduction required for Big Dalton Wash and Eaton Wash.

A summary of the recommended green streets required as well as each proposed regional BMP to meet the pollutant reduction requirements are included in **Table 9** and **Table 10**. See the exhibits at the end of Appendix B.1 through B.4 for regional project Preliminary Capital Construction Cost Estimates, Project Concept Layouts, and the Project Fact Sheets. The Green Street Fact Sheets can be found in Appendix B.5.

**Table 9.** Regional BMP Project Summary Table

Parameter	RH Regional BMP			SGR Regional BMP	
	Arboretum Wetland Pond	Arboretum Recharge Pond (each side)	Rio Hondo Wetland	Encanto Underground Storage	Basin 3E Detention Basin
Length (feet)	500	500	2400	75	550
Width (feet)	50	30	150	150	180
Height (feet)	2.5	3	4	5	5
Diversion Rate (cfs)	30	N/A	185 (Sawpit Wash) + 37 (Arcadia Wash)	3	N/A
Cost (\$)	\$89,171,846			\$5,382,077	
Load Reduction (lb/yr)	854.0 (22.3%)			64.3 (7.5%)	

**Table 10.** Green Street Recommendation Summary Table

	Total Footprint (acres)	Total Length* (miles)	Cost, Including 20 Year O&M (Million \$)	Load Reduction (lb/yr)	Treated Drainage Area (acres)
<b>Big Dalton Wash</b>	3.8	7.8	11.4	54.7 (3.7%)	674.7
<b>Eaton Wash</b>	5.2	10.7	15.8	59.5 (18.4%)	326.6

**\*Note:** Assumed 4' width.

These project concepts are preliminary in nature based on available as-builts and water quality analysis; therefore, additional investigations are required to further develop the proposed project concepts. The following are the recommended studies that are required prior to moving forward towards the design phase of the projects.

- Geotechnical investigations, consisting of soil borings and infiltration testing, are required to determine the subsurface soil profile, depth to groundwater, and infiltration rates.
- Hydrology and hydraulic analyses for all applicable storm drain and channel diversions to appropriately design the sizing required for each diversion structure and pipes.

## 9.0 REFERENCES

- Los Angeles County Flood Control District. *Los Angeles County Storm Drain System*.  
<http://dpw.lacounty.gov/fcd/stormdrain/index.cfm>
- Los Angeles County Flood Control District . 1970. *As-built drawing for Arboretum Drains showing manholes, catchbasins, and inlet structures (FD1001301)*. April 1970.
- Los Angeles County Flood Control District . 1968. *As-built drawing for the Los Angeles County Flood Control District storm drain on Las Tunas Drive connecting to Arcadia Wash (PD033432, Drawing No. 364-602-D2.4)*. June 11, 1968.
- Los Angeles County Flood Control District . 1956. *As-built drawings for Bradbury Channel (PD005136, Drawing No. 30-D19)*. April 1956.
- Los Angeles County Department of Public Works. 2005. Santa Fe Spreading Grounds Operational Map. March, 2005. Revised by O. Pongpun and A. Ward.
- Los Angeles County Department of Public Works. 2005. Peck Road Spreading Basin Operational Map. March 2005. Revised by O. Pongpun and A. Ward.
- Cuenca, Fernando and Skopek, Peter. Tetra Tech. "*Desktop Evaluation Report, Preliminary Infiltration Feasibility Study, Rio Hondo and San Gabriel River EWMP Group, SW of Intersection between Peck Road and Live Oak Avenue, Arcadia, CA*" (Project No. TET 18-146E). February 14, 2018.
- "About | The Arboretum." *Los Angeles County Arboretum & Botanic Garden*, The Arboretum, [www.arboretum.org/about](http://www.arboretum.org/about).
- "Section 408." Headquarters U.S. Army Corps of Engineers, USACE, 1899, [www.usace.army.mil/Missions/Civil-Works/Section408/](http://www.usace.army.mil/Missions/Civil-Works/Section408/).
- United States, Congress, Los Angeles Region. "Order No. R4-2012-0175, NPDES Permit No. CAS00401." Order No. R4-2012-0175, NPDES Permit No. CAS00401. [www.waterboards.ca.gov/losangeles/water\\_issues/programs/stormwater/municipal/la\\_ms4/2012/Order%20R4-2012-0175%20-%20A%20Final%20Order%20revised.pdf](http://www.waterboards.ca.gov/losangeles/water_issues/programs/stormwater/municipal/la_ms4/2012/Order%20R4-2012-0175%20-%20A%20Final%20Order%20revised.pdf).



**APPENDIX B.1 ARCADIA ARBORETUM NATURAL TREATMENT AND  
GROUNDWATER RECHARGE PROJECT EVALUATION**

## CONTENTS

---

<b>1.0 SITE DESCRIPTION AND EXISTING HYDROLOGY</b> .....	<b>3</b>
1.1.1 Land Use Distribution .....	6
1.2 Existing Water Quality .....	6
1.3 Preliminary Geotechnical Findings .....	6
1.3.1 Existing Soil Types .....	7
1.3.2 Ground Water .....	7
1.3.3 Geotechnical Summary .....	7
<b>2.0 BMP DESIGN COMPONENTS</b> .....	<b>8</b>
2.1 Site Layout .....	9
2.2 Diversion Structure Analysis .....	10
2.3 Pretreatment .....	11
2.4 Natural Treatment and Recharge .....	11
<b>3.0 MONITORING PLAN</b> .....	<b>13</b>
3.1 Water Quality Monitoring.....	13
3.1.1 Flow Monitoring Methods .....	13
3.1.2 Composite Sampling Methods .....	13
3.2 Long-Term Performance Monitoring .....	13
<b>4.0 PERMITTING, SCHEDULE, AND COST ESTIMATE</b> .....	<b>14</b>
4.1 Environmental Documents and Permits.....	14
4.1.1 CEQA/NEPA.....	14
4.1.2 Local Construction Permits.....	15
4.2 Schedule .....	15
4.3 Cost Analysis .....	15
4.3.1 Construction Cost .....	15
4.3.2 Implementation Costs .....	17
4.3.3 Operations & Maintenance Cost .....	17
<b>EXHIBIT B.1.1 SITE PLAN</b> .....	<b>19</b>
<b>EXHIBIT B.1.2 FACT SHEET</b> .....	<b>21</b>

## LIST OF TABLES

---

Table 1. Land Use Distribution Summary.....	6
Table 2. Groundwater Wells in the Vicinity of the Site .....	7
Table 3. BMP Optimization Results.....	9

---

Table 4. Project Implementation Schedule..... 15  
Table 5. Construction Cost Estimate ..... 16  
Table 6. Total Project Cost ..... 17  
Table 7. Annual Estimated Operations & Maintenance Costs ..... 17

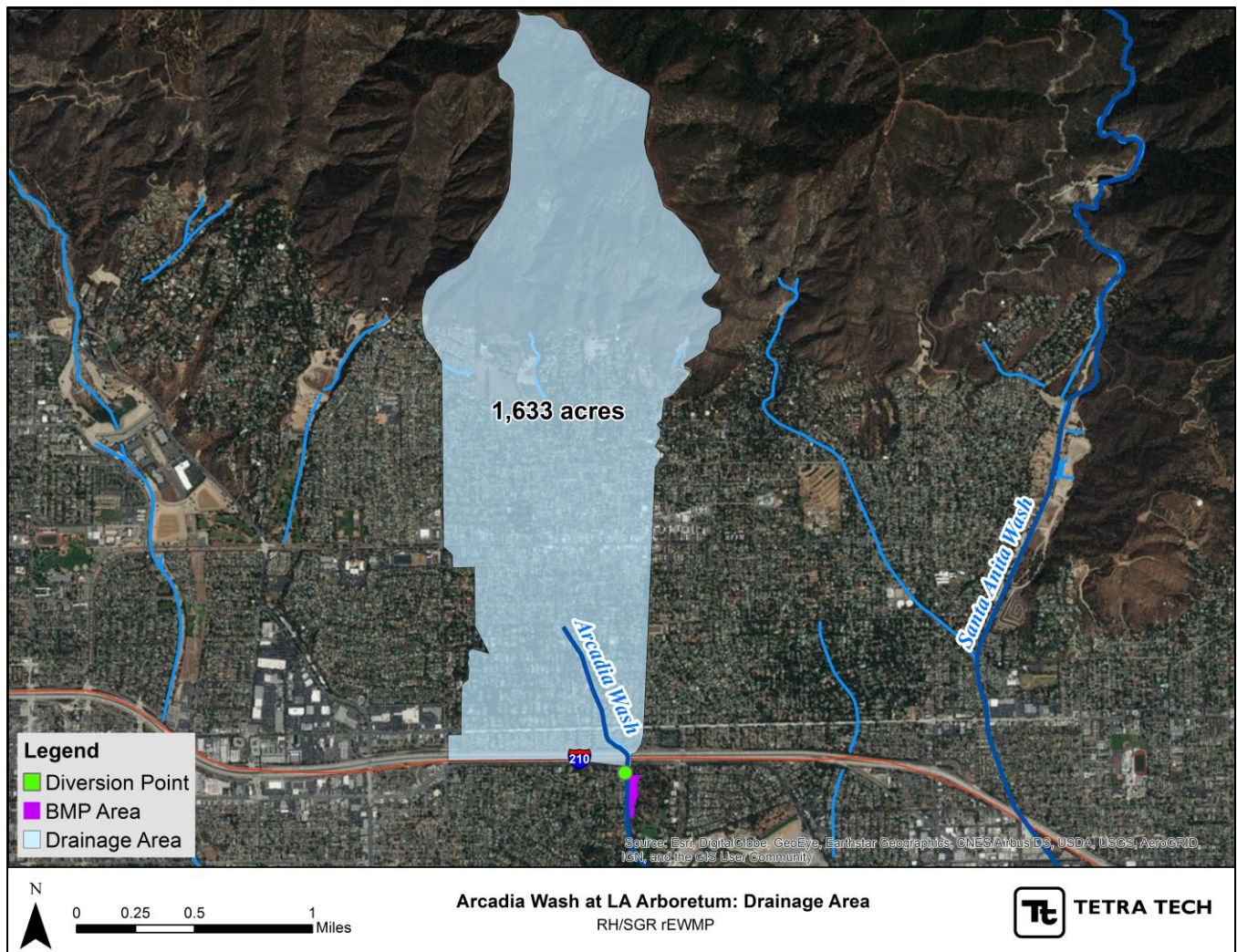
## LIST OF FIGURES

---

Figure 1. Arcadia Wash Drainage Map at Arboretum Diversion Point .....3  
Figure 2. Arboretum Area of Interest .....4  
Figure 3. Arcadia Wash Adjacent to Arboretum (left) and Area Adjacent to Arcadia Wash Looking Northwest to Southeast (right) .....4  
Figure 4. Tule Pond Existing Conditions and Outlet Structure .....5  
Figure 5. Baldwin Lake Looking West Towards Tule Pond Outlet .....5  
Figure 6. Cost-Effectiveness Curve for Regional Projects within the Rio Hondo Drainage Area (note that modeled costs are relative – see engineering cost estimated in each appendix) .....8  
Figure 7. Rendering of the Arboretum BMP Wet and Dry Ponds.....9  
Figure 8. Arcadia Arboretum Natural Treatment and Groundwater Recharge Project Site Layout ..... 10  
Figure 9. Typical Hydrodynamic Separator ..... 11  
Figure 10. Wetland Cross Section with Outlet Structure ..... 12  
Figure 11. Typical Cross Section..... 12

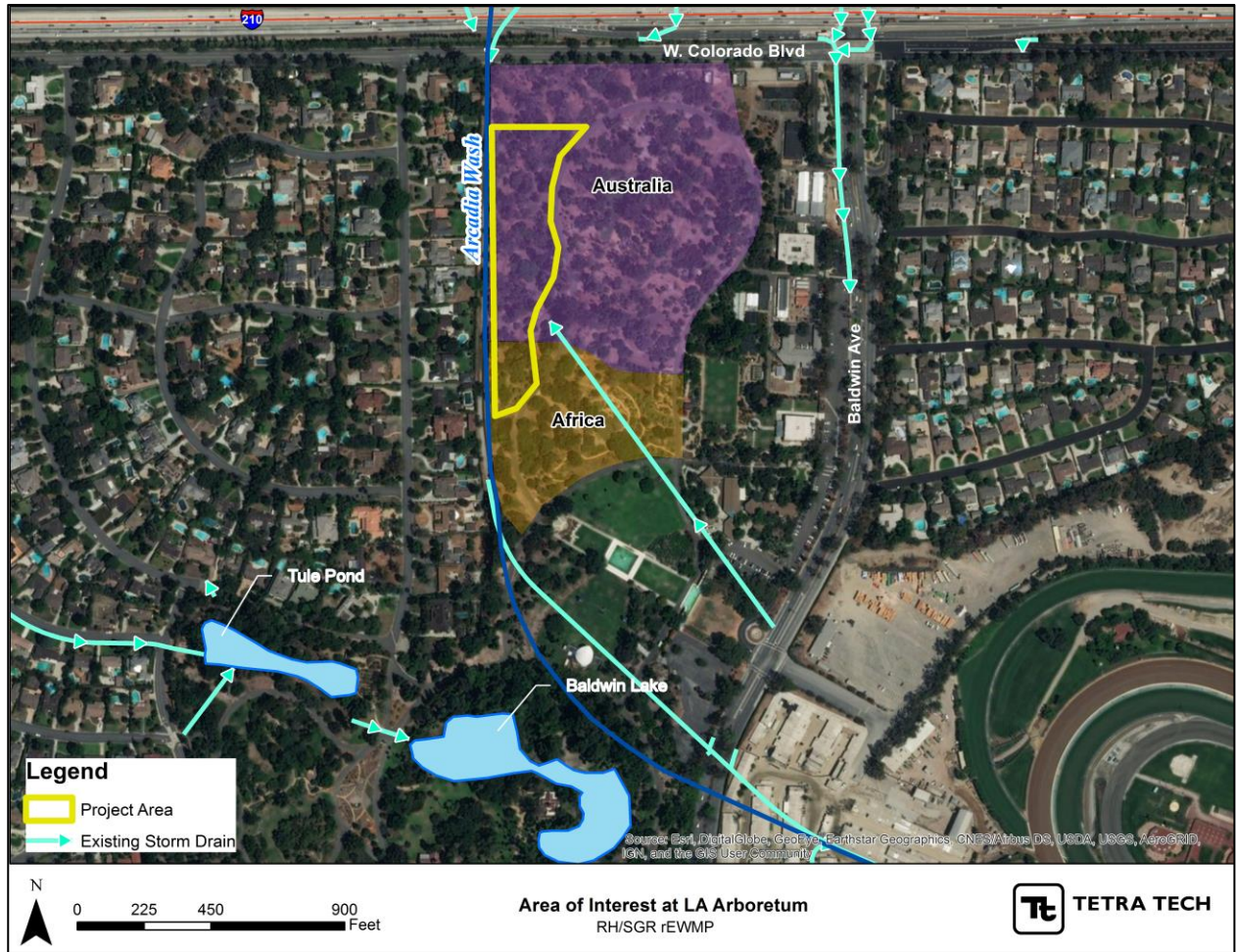
## 1.0 SITE DESCRIPTION AND EXISTING HYDROLOGY

The Los Angeles Arboretum and Botanic Garden is a 127-acre facility location in the City of Arcadia that exists to cultivate natural, horticultural, and historical resources for learning, enjoyment and inspiration (“About | The Arboretum”). Arcadia Wash is a large concrete flood control channel, which runs adjacent to the western edge of the Arboretum, that drains stormwater flows from the Cities of Arcadia and Sierra Madre through the upstream storm drain system directly into the Rio Hondo Tributary (**Figure 1**). At the project location, southeast of the intersection of Arcadia Wash and the 210 Freeway, Arcadia Wash has a tributary drainage area of 1,633-acres. Much of the drainage area is characterized by urban irrigated grass and vacant steep slope, which is due to the San Gabriel Mountains in the Los Angeles National forest as well as the residential housing that is south of the foothills.



**Figure 1.** Arcadia Wash Drainage Map at Arboretum Diversion Point

The Arboretum consists of many different plant collections, natural water features, and historical learning opportunities. The area of interest for this project is located within the African and Australian Collections that encompass a large section of the Arboretum, bounded by Arcadia Wash to the west, Bauer Lawn and Fountains to the south, administrative and greenhouse buildings to the east, and W. Colorado Boulevard to the north (**Figure 2**).



**Figure 2.** Arboretum Area of Interest

This area is currently planted with various trees, ranging in maturity. There is a meandering asphalt walking path that borders the eastern edge of the project area that is approximately 200 feet away from Arcadia Wash. Arcadia Wash is a Large concrete channel (approximately 14’W by 12’H) that has a chain link fence surrounding its walls. The surrounding adjacent area as mentioned is planted with trees and shrubs but does have some open space as shown in the existing site photos below (**Figure 3**).



**Figure 3.** Arcadia Wash Adjacent to Arboretum (left) and Area Adjacent to Arcadia Wash Looking Northwest to Southeast (right)

There are two existing water body features at the Arboretum which are of interest in the Tule Pond and Baldwin Lake. Tule Pond collects stormwater runoff from residential area to the west by three catch basins, located on Vaquero Road and N. Golden W. Avenue, with drain lines to the pond. The outlet for Tule Pond is a weir structure with a 48-inch RCP pipe that drains to Baldwin Lake (**Figure 4**), and is the main source of water supply for Baldwin Lake. Due to the land use and watershed characteristics, Tule Pond and consequently Baldwin Lake have been accumulating with sediment carried by the run-off. The three storm drain outlets to Tule Pond have been buried in sediment causing Tule Pond to be a dry water bed.

Baldwin Lake used to be a ten-foot-deep basin, but over the years of sediment accumulation and surrounding erosion the lake has become shallow and stagnant, creating a vector control hazard and habitat degradation (**Figure 5**). The Arboretum is seeking ways to restore Baldwin Lake, which will require a sustainable source of water that is not sediment laden.



**Figure 4.** Tule Pond Existing Conditions and Outlet Structure



**Figure 5.** Baldwin Lake Looking West Towards Tule Pond Outlet

### 1.1.1 Land Use Distribution

Understanding the tributary watershed land use can provide further insight into the best approach to be taken in the water quality assessment. The table provided below characterizes the land use distributions based on the Loading Simulation Program utilized in the water quality analysis performed for the feasibility study.

**Table 1.** Land Use Distribution Summary

Land Use	Area (acres)	Percent of Total Area
Commercial	16.4	1%
HD single-family residential	128.7	8%
Industrial	11.0	1%
Institutional	37.6	2%
LD single-family residential moderate slope	13.9	1%
LD single-family residential steep slope	1.8	0%
Multifamily residential	37.4	2%
Secondary roads	82.5	5%
Transportation	23.5	1%
Urban grass Irrigated	531.9	32%
Urban grass Non-irrigated	214.5	13%
Vacant moderate slope B	0.4	0%
Vacant moderate slope D	5.2	0%
Vacant steep slope B	191.8	11%
Vacant steep slope C	373.0	22%
Vacant steep slope D	13.8	1%

## 1.2 EXISTING WATER QUALITY

For this study, the Los Angeles County Watershed Management Modeling System (WMMS) was used within the LSPC to simulate contaminant loading, runoff volume, and other baseline hydrology parameters. A more detailed description on the watershed modeling methodology and results that informed this feasibility study can be found in the revised Reasonable Assurance Analysis (RAA) in Attachment C of the rEWMP. The results from the revised RAA recommended using the critical water year as the critical condition for compliance, which was 2003 for the Rio Hondo. The limiting priority pollutant used in the water quality analysis based on the existing conditions was zinc.

The Rio Hondo Watershed has a drainage area of 148,183-acres. The Arboretum Natural Treatment System and Groundwater Recharge Project is one of two regional BMP sites in the overarching feasibility study that is located within the Rio Hondo Watershed.

## 1.3 PRELIMINARY GEOTECHNICAL FINDINGS

At this stage in the EWMP process, geotechnical investigations were not performed. Preliminary research on the existing soils and groundwater conditions of the project area was performed to assess the feasibility of the project area as a regional BMP site. The geotechnical findings presented in this section are limited in nature, and will require subsurface soils explorations to verify feasibility.

### 1.3.1 Existing Soil Types

Based upon findings from a web soil survey provided by National Resource Conservation Service (NCRS), the soils at the site below the invert of the proposed BMP facility range from gravely sandy loam to very cobbly sand, with good drainage characteristics. NCRS’s interpretation of these soils correspond to a Hydrologic Soil Group of both A and B, with 30% of the soil composition in the “A” group. The capacity of the most limiting layer to transmit water ranges from 5.95 to 19.98 in/hr for the “A” soils to 0.57 to 1.98 in/hr for the “B” soils. The minimum required infiltration rate established by the Los Angeles County Department of Public Works (LACDPW) guidelines for in-site infiltration systems is 0.3 in/hr. The preliminary findings suggest that the project area has the potential to meet the minimum infiltration rate, but this cannot be determined until a subsurface investigation is performed.

### 1.3.2 Ground Water

A review of the well data from the LACDPW database (<http://dpw.lacounty.gov/general/wells/>) and the Geotracker database (<http://geotracker.waterboards.ca.gov/gama/>) for nearby wells was conducted and indicate groundwater depths as summarized in **Table 2**. As shown, the shallowest groundwater depth was recorded at 2.5 feet in 1983. Further assessment of LACDPW Well 4145G showed that since 1983 the shallowest groundwater depth observed was 23.7 feet in 1986. Based on this database search, preliminary results show that the groundwater has been deeper than 20 feet within the last 30 years. Based on the most recent results of groundwater depth nearby the site, it can be assumed that the last 30 years provide an accurate assessment of the current conditions and can be estimated as deeper than 20 feet for this site. This research suggests that groundwater is not expected to impact the design and construction of the proposed BMP.

**Table 2.** Groundwater Wells in the Vicinity of the Site

Well Identification	Monitoring Period	Approximate Location Relative to the Site	Shallowest Groundwater Depth (within the last 50 years)	Last Measured Depth
State #01N11W29G01 LACDPW Well ID: 4145G	Jan. 1931 to Oct. 2007	0.1 miles to the west	2.5 feet on Nov.1983	188.6 feet on Oct. 2007
State #01N11W29G001S	Apr. 2011 to Oct. 2016	0.25 miles to the south	58.9 feet on Oct. 2016	58.9 feet on Oct. 2016
State #01N11W28C002S	Apr. 2013 to Oct. 2016	0.64 miles to the northeast	121 feet on Apr. 2013	129.6 feet on Oct. 2016
State #01N11W30R03 LACDPW Well ID: 4136K	Jul. 1971 to Nov. 2013	0.89 miles to the southwest	73.2 feet on Apr. 1984	185 feet on Nov. 2013
State #01N11W29M02 LACDPW Well ID: 4136A	Oct. 1924 to Sept. 2010	0.79 miles to the southwest	51.5 feet on Apr. 1970	151 feet on Sept. 2010

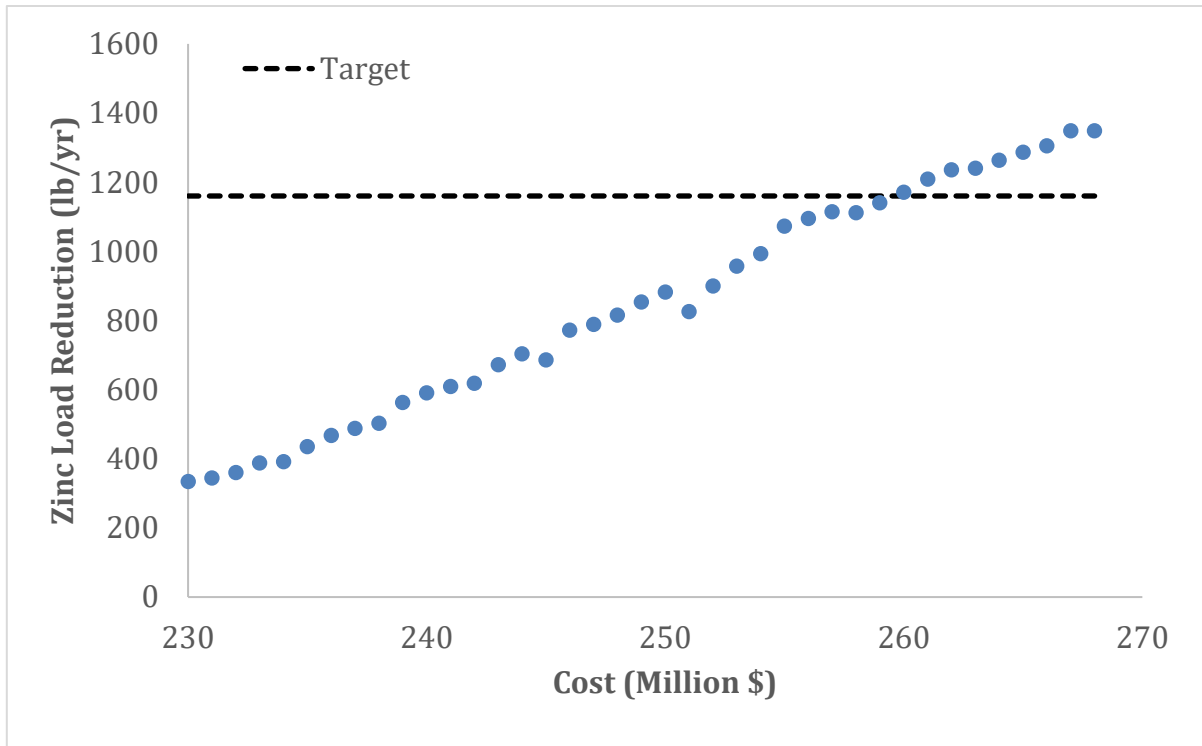
### 1.3.3 Geotechnical Summary

Based on the results of the preliminary desktop geotechnical investigation, it is Tetra Tech’s initial opinion that the proposed construction is feasible from a geotechnical standpoint. Once further soil exploration is performed, more definitive conclusions can be provided regarding the infiltration capabilities and groundwater constraints at this site.



## 2.0 BMP DESIGN COMPONENTS

The optimum BMP footprint and diversion rate was determined for the BMP site based on the long-term average annual zinc reduction, simulated using the EPA System for Urban Stormwater Treatment and Analysis Integration (SUSTAIN) model. To optimize the selection and placement of BMPs, SUSTAIN iteratively runs different combinations of BMP properties, varied within a specified range, to generate a cost-effectiveness curve (**Figure 6**). These curves show the additional load reductions from potential multi-benefit regional project configurations, beyond that already achieved from redevelopment projects and MCMs. The recommended BMP sizes and diversion rates to BMPs are based on the most cost-effective scenario.



**Figure 6.** Cost-Effectiveness Curve for Regional Projects within the Rio Hondo Drainage Area (note that modeled costs are relative – see engineering cost estimated in each appendix).

The annual critical condition for load reduction requirements was determined by comparing the average rainfall within a ten-year period (2002-2011) that was closest to the 90<sup>th</sup> percentile average rainfall. The runoff treated by the BMP was then simulated over this ten-year period using critical water year determined for the Rio Hondo Watershed as 2003. Configurations of the multi-benefit regional projects which meet the required load reductions and exhibit the maximum performance for the given cost were reviewed and the recommended configuration is presented below (**Table 3**). Since the BMP optimization for Rio Hondo Watershed is based on all tributary BMPs, the achieved load reduction and cost presented below are associated with the implementation of both this project and the downstream Rio Hondo Ecosystem Restoration project.

**Table 3.** BMP Optimization Results

Parameter	Arboretum Wet Pond	Arboretum Recharge Pond (each side) <sup>1</sup>
Length (ft)	500	500
Width (ft)	50	30
Height (ft)	2.5	3
BMP Capacity (ac-ft)	1.4	N/A
Diversion Rate (cfs)	30	N/A
Load Reduction <sup>2</sup> (lbs/yr)	35.7 (0.93%)	

**Notes:**

1. The concept layout has a wetland pond in the center, with a recharge pond on both sides of the wetland pond.
2. Existing Wet Days Zn Load for the Rio Hondo was 3,822 lbs/yr.

## 2.1 SITE LAYOUT

The regional BMP system will divert runoff from Arcadia Wash to a sediment forebay for pretreatment, with flows then entering a wetland surrounded by two groundwater recharge ponds. This system will have a controlled outlet with pump station to convey up to 1 cfs of treated water through a meandering stream to Baldwin Lake. A rendering was created in **Figure 7** to show a conceptual picture of what the BMP system could look like when both the wet and dry ponds are full (looking from northwest to southeast).



**Figure 7.** Rendering of the Arboretum BMP Wet and Dry Ponds

In addition to the Arcadia Wash diversion, this layout proposed the reconstruction of three catch basins (on Vaquero Rd and N. Golden W. Ave) with green street mechanisms, such as biofiltration, to treat the water previously being conveyed to Tule Pond. The green streets will be connected via storm drain and conveyed to a pretreatment device before being conveyed with by pipe via gravity to Baldwin Lake. Tule Pond is no longer necessary for treatment, and can be filled with dirt and restored as a new area for planting. The site layout is shown in **Figure 8** can also be found in Exhibit B.1.1.



**Figure 8.** Arcadia Arboretum Natural Treatment and Groundwater Recharge Project Site Layout

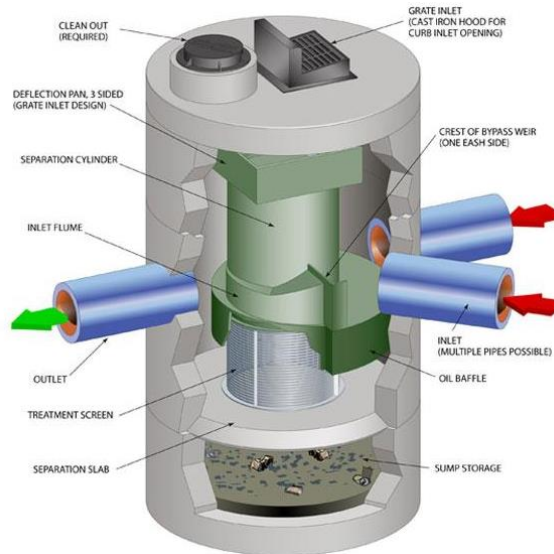
## 2.2 DIVERSION STRUCTURE ANALYSIS

The optimal flow rate determined from the water quality analysis was 30cfs. For wet weather flow diversion, an inflatable rubber dam (similar to the gates manufactured by Obermeyer Hydro Inc.) will be constructed. The inflatable dam will impound runoff to raise the water level 3 feet in Arcadia Wash, to convey flow to the system via gravity by a 30-inch RCP with a trash rack installed at the opening. For dry weather flows will enter the system by a grated drop inlet just downstream of the inflatable dam (not in operation in this condition) with a dry weather pump station to raise the water to the surface sediment basin.

## 2.3 PRETREATMENT

Stormwater runoff transports sediment, trash, and debris that can compromise the performance of stormwater facilities and pollute receiving waters. Pretreatment will be an integral component of the treatment strategies to extend the life of the proposed systems. Pretreatment is recommended in order to reduce the maintenance frequency of the BMP site stormwater facilities and to focus maintenance efforts to a concentrated area. Two means of pretreatment are being recommended for the Arcadia Wash diversion. The first method is by collecting trash via a grated cover over the wet weather storm drain diversion pipe or a grated drop inlet for the dry weather diversion. These grates will screen large trash and debris from entering into the system. The secondary pretreatment method is a sediment forebay upstream of the BMP facility. The sediment basin will allow for the fine particles to settle, conveying the less turbid flows by a gate or spillway connection to the wetland.

For the Tule Pond reconstruction, the stormflows will be routed from each catch basin and green street biofiltration mechanism to a hydrodynamic separator type pretreatment device. A typical hydrodynamic separator collects stormwater runoff on one or more sides of the structure then directs the water into a separation chamber where water begins swirling, forcing the particles out of the runoff. One-hundred percent of floatables and neutrally buoyant debris larger than the screen aperture is collected. Hydrodynamic separators typically have an 80% removal rate if total suspended solids (TSS). With the chambered system, hydrocarbons float to the top of the water surface and are prevented from being transported downstream. The size of the unit will be selected based on the estimated sediment removal and the routine maintenance required. **Figure 9** represents a typical Contech CDS type hydrodynamic separator.



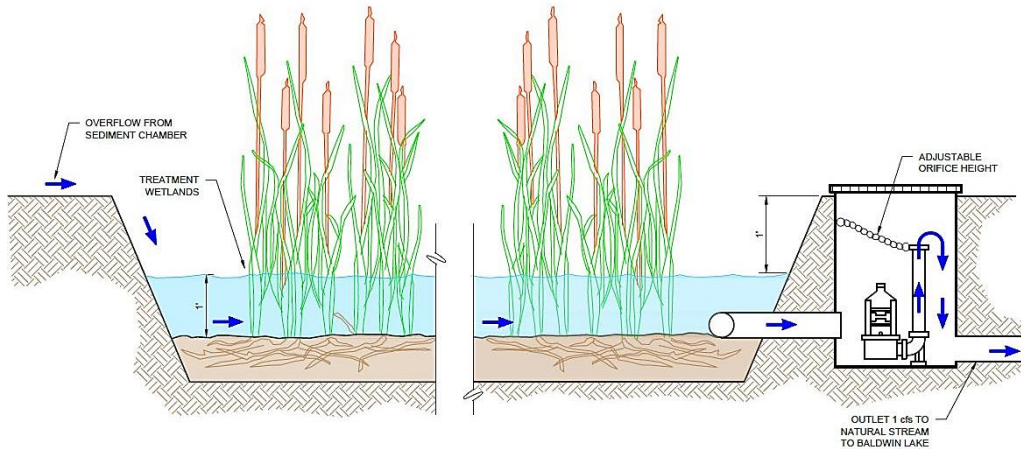
**Figure 9.** Typical Hydrodynamic Separator

Source: Contech Engineered Solutions

## 2.4 NATURAL TREATMENT AND RECHARGE

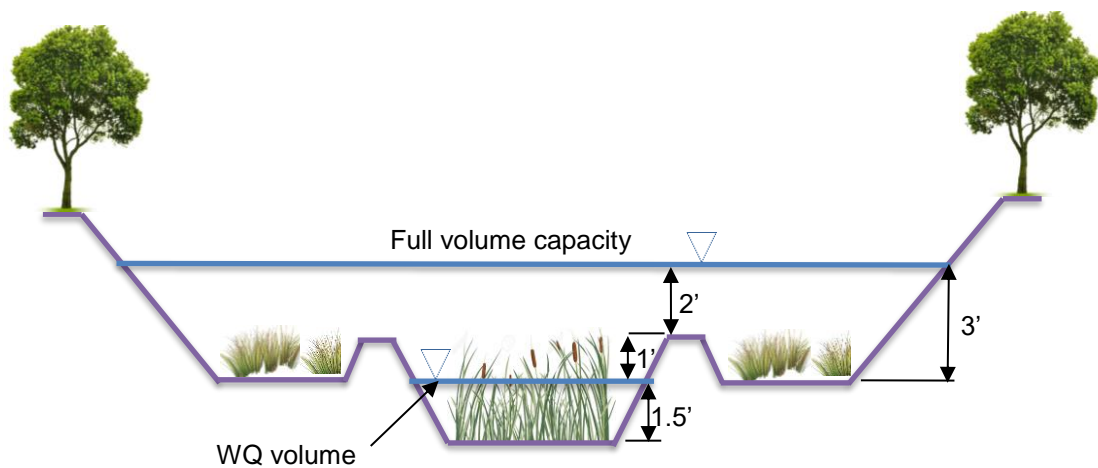
The wetland pond is the primary means of regional treatment for this site. According to California Stormwater Quality Association's (CASQA) BMP Handbook, constructed wetlands are constructed basins that have a permanent pool of water throughout the year (or at least during the wet season) and are shallow in depth with vegetation cover on the bottom. As stormwater flows through the wetland, pollutant removal is achieved through settling and biological uptake within the wetlands. Specific plants are chosen that will effectively remove nutrients

and dissolved pollutants from the stormwater through the root systems of the vegetation. The constructed wetland for this project will hold a water depth of 1.5 feet, with 1 foot of freeboard between the water surface and the berms separating the wetland from the recharge ponds. The cross-section in **Figure 10** shows an example wetland planting system with an outlet structure.



**Figure 10.** Wetland Cross Section with Outlet Structure

In larger storm events when the stormwater depth exceeds the 1.5-foot wetland ponding, the runoff will continue to fill the pond and drain into the surrounding groundwater recharge ponds via pipe and gate connections or an overflow connection. The invert of the recharge ponds will be at the same elevation as the ponding surface for the wetland, and will provide an additional 3 feet of depth for the system. The recharge ponds will fill with water and infiltrate into the Raymond Groundwater Basin, providing approximately 100 ac-ft/yr of recharge. This system is designed to drain the groundwater recharge basins within a maximum 72-hour period to sustain the health of the wetland vegetation by avoiding extended periods of inundation. The cross-section in **Figure 11** shows a schematic for the entire BMP section.



**Figure 11.** Typical Cross Section

At the downstream end of the wetland there will be an outlet structure constructed to convey 1cfs to a pump station that will raise the water back to the adjacent surface elevation at the top of the basin grading. The natural stream will surface flow via gravity over Arcadia Wash and outlet into Baldwin Lake. This will provide a sustainable water source to the lake and benefit habitat restoration as well as new habitat area potential surrounding the stream.

## 3.0 MONITORING PLAN

There are two goals of a monitoring plan: 1) water quality monitoring to document the performance of the BMP and to demonstrate compliance with the EMWP, and 2) long-term monitoring to maintain and track performance and predict required maintenance.

### 3.1 WATER QUALITY MONITORING

---

To verify the performance of the regional structural BMPs, flow weighted composite samples should be collected at the inlet and the outlet of the system. The exact monitoring locations will be determined upon further project implementation. At minimum, the samples should be analyzed for Zinc. It is recommended that analysis include all priority pollutants identified in the RH/SGR Coordinated Integrated Monitoring Program (CIMP).

#### 3.1.1 Flow Monitoring Methods

Flow at the BMP inlet location should be measured at pre-programmed intervals using an area-velocity bubbler (AVB) flow meter with an AVB sensor. Flow at the outlet should be measured using a Thel-Mar volumetric compound weir, which is capable of measuring low flows with a high degree of accuracy. A bubbler flow meter is recommended to measure flow depth behind the rubber dam in wet weather, which is then converted to a flow rate by the flow meter. The flow meter will continuously log the flow measurements at regular intervals during monitoring events.

#### 3.1.2 Composite Sampling Methods

A flow-weighted composite sample is comprised of a series of sample aliquots collected over the course of a storm event where the sample aliquot frequency is determined by a constant incremental flow volume measured by the flow meter. To collect the sample, a flow meter is pre-programmed with a pacing volume. When the accumulated flow reaches the pacing volume, the flow meter will trigger an automated sampler to collect a sample aliquot. This process continues until the storm ends. The pacing volume is determined by storm event forecast and the anticipated total volume of runoff. Ideally, pacing volumes will be set to fill one composite bottle for the duration of rainfall to ensure sufficient sample volume for all analyses; however, stormwater runoff durations may be shorter or longer (or the rainfall intensity may be less or greater) than anticipated. If the rainfall duration is longer than that predicted, additional clean, empty bottles may be added to the sampling system. The automated sampler should log the sample information during the course of the monitoring event.

### 3.2 LONG-TERM PERFORMANCE MONITORING

---

Additional monitoring equipment, including water level meters and soil moisture sensors, are recommended to monitor and track the long-term performance of the regional structural BMPs. A continuous monitoring system can provide significant insight into the current and long-term performance of the BMP. A water level logger at the surface of the soil media can collect data on the ponding depth and ultimately determine the infiltration rate at the surface. This data can be used to determine the performance throughout a rain event and demonstrate any decreases in performance from the start of the rain event to the end; an overall reduction in infiltration could indicate an impending maintenance need allowing staff to predict when maintenance will be required rather than reacting to a visual indicator. A soil moisture sensor strategically placed in the BMP could also indicate if the system is performing as designed and identify any potential performance limitations.

## 4.0 PERMITTING, SCHEDULE, AND COST ESTIMATE

A preliminary cost estimate and schedule has been created to give the EWMP group an idea of the funds that will need to be secured to construct this regional BMP facility as well as validate that the BMP site will meet milestones set forth in the EWMP.

### 4.1 ENVIRONMENTAL DOCUMENTS AND PERMITS

---

Consultation with regulatory agencies and acquisition of permits is required before the project components can be constructed. The following sections summarize regulatory permits and approvals relevant to the project.

#### 4.1.1 CEQA/NEPA

A governmental agency is required to comply with California Environmental Quality Act (CEQA) procedures when the agency proposes to carry out or approve the activity/project. CEQA considers a “project” to be the whole of an action, which has a potential for resulting in either a direct physical change in the environment, or a reasonably foreseeable indirect physical change in the environment. The preparation of an Initial Study (IS) is typically the first step for projects determined not to be exempt from CEQA requirements. Initial Studies allow decision-makers the opportunity to review a proposed project and to make an environmental determination recommending the follow-on CEQA document. Initial Studies consider all phases of project planning, implementation, and operation and utilize the CEQA Guidelines IS Checklist form that covers 17 environmental resources topics. If the IS identifies that there is no substantial evidence that the project may have a significant impact on the environment (without or with mitigation) then a Negative Declaration (ND) or Mitigated Negative Declaration (MND) may be prepared. In the unlikely event the IS identifies that the project may have a significant impact on the environment, then an Environmental Impact Report (EIR) would be required. A description of investigations that may be required are included below.

Compliance with the National Environmental Policy Act (NEPA) would be required if there is a federal nexus (such as federal funding). In addition, the project will need to comply with the implementing procedures of the applicable federal agency.

##### 4.1.1.1 Historical Resources

The Historical Resources assessment will investigate the occurrence of historically significant areas within the vicinity of a proposed project site, namely sites listed on or eligible for designation by the California Register of Historical Resources (CRHR). A resource should be considered a historical resource if it has previously been identified as significant in a historical resources survey.

If a Lead Agency is unsure about a resource, they should consider hiring a professional historian or archeologist who meets the Secretary of the Interior Standards Professional Qualifications for History, Architectural History, or Archeology. However, CEQA ultimately delegates final authority to the Lead Agency to determine if a resource is historically significant or not (CEQA Case Studies).

Similar projects within recent years to the submission of this report have identified historical wheat farms from the 1870s and shipper centers from the 1920s, which had no official historical designations.

##### 4.1.1.2 Archaeological Resources

Investigations by institutions such as The Native American Heritage Commission’s search of the Sacred Lands Inventory will likely be required for full compliance. Further assessments for isolated artifacts or stream or topographical formations may also indicate the presence of subsurface prehistoric archaeological resources during excavation.

### 4.1.1.3 Paleontological Resources

Paleontological records may be assessed for records of known vertebrate fossils within the proposed project areas, as well as within older, sedimentary deposits.

### 4.1.1.4 Burial Sites

An investigation of known burial sites will occur prior to construction. In the event that an unknown burial site or human remains are found during excavation, mitigation should be implemented so that potential impacts remain at a less than significant level.

## 4.1.2 Local Construction Permits

The City of Arcadia may require building and grading permits for construction of this design. Traffic control will play an integral role in construction of the facility and the impacts of hauling export soils from the project during the excavation phase.

## 4.2 SCHEDULE

---

An estimated project schedule is outlined in **Table 4**. The feasibility study will accomplish 10% level design. The design task includes predesign (30-60% design level) and final design (60-100% design).

**Table 4.** Project Implementation Schedule

Task	Start	Finish
Feasibility Study	1/11/2018	1/11/2023
Design	1/11/2023	1/11/2024
Environmental Documentation (IS/MND) & Permitting	1/11/2023	7/11/2025
Bid & Award	7/11/2025	1/11/2026
Construction	1/11/2026	1/11/2028

## 4.3 COST ANALYSIS

---

The cost analysis is utilized as a tool to ensure the preliminary design is within the amount of funds available to the project. If the cost analysis indicates that the project is not feasible, then the design will need to be adjusted to bring it within the project budget, while still meeting the project goals. The cost analysis was developed using various sources of information, as well as the Cost Estimator’s judgement. A summary of the total costs will be provided after the construction and implementation cost discussion.

### 4.3.1 Construction Cost

The construction costs entail various components of the projects that a Contractor would construct for the City. Construction costs do not include items of work not directly performed by the Contractor, such as a City’s construction management during construction. The construction costs were developed using various source of cost information. Unit costs were based on Caltrans historical data and RSMeans cost data. All costs were approximately adjusted to 2018 dollars based respectively on the Caltrans Construction Cost Index and RSMeans Historical Cost Index. The estimated capital construction costs for the proposed BMP are listed in **Table 5**.



**Table 5. Construction Cost Estimate**

ITEM NO	DESCRIPTION	QUANTITY	UNIT	UNIT PRICE	TOTAL
<b>Arcadia Wash Diversion, Pretreatment, and Conveyance</b>					<b>\$316,450</b>
1	Inflatable Gate Diversion (12-ft wide by 4-ft high)	1	EA	\$120,000.00	\$120,000
2	Channel Wall Modifications for New Intake	1	LS	\$7,000.00	\$7,000
3	Trash Rack for Diversion	1	EA	\$2,500.00	\$2,500
4	Active Control System	1	EA	\$75,000.00	\$75,000
5	Diversion Pipe (30-inch)	50	LF	\$375.00	\$18,750
6	Excavation for Conveyance Channel to Sediment Forebay	100	CY	\$15.00	\$1,500
7	Sluice Gate Between Basins	3	EA	\$20,000.00	\$60,000
8	Grading for Natural Creek Conveyance to Baldwin Lake	300	CY	\$15.00	\$4,500
9	Hauling	300	CY	\$30.00	\$9,000
10	Jack and Bore Arcadia Wash for Conveyance to Baldwin Lake	14	LF	\$1,300.00	\$18,200
<b>Dry Weather Pump Station</b>					<b>\$800,000</b>
11	Electical Service, Controls, and Instrumentation	1	LS	\$550,000.00	\$550,000
12	Grated Inlet and Dry Weather Pump Station (1.5 cfs)	1	LS	\$250,000.00	\$250,000
<b>Treatment and Recharge Ponds</b>					<b>\$2,565,600</b>
13	Excavation for Site Preparation	36,000	CY	\$15.00	\$540,000
14	Excavation for Wetland	3,000	CY	\$15.00	\$45,000
15	Excavation for Recharge Ponds	3,500	CY	\$15.00	\$52,500
16	Backfill, Fine Grading, and Compaction	1,500	CY	\$25.00	\$37,500
17	Wetland Planting (Irrigation & Plant Establishment)	25,000	SF	\$4.00	\$100,000
18	Hauling	27,270	CY	\$30.00	\$818,100
19	Pump Station for Flow to Baldwin Lake (5 CFS)	1	EA	\$200,000.00	\$200,000
20	Removal of Mature Trees	50	EA	\$1,000.00	\$50,000
21	General Site Improvements ( trails, benches, lodge poll fencing)	1	LS	\$300,000.00	\$300,000
22	Surrounding Planting and irrigation	100,000	SF	\$4.00	\$400,000
23	Gravel Access Road to Maintain Diversion	3,000	SF	\$7.50	\$22,500
<b>Green Streets for Tule Pond Treatment</b>					<b>\$851,360</b>
23	Pretreatment Unit	1	EA	\$75,000.00	\$75,000
24	Green Street Treatment Devices	3	EA	\$5,000.00	\$15,000
25	Diversion Pipe (18-inch)	225	LF	\$275.00	\$61,875
26	Diversion Pipe (30-inch)	50	LF	\$375.00	\$18,750
27	Diversion Pipe (54-inch)	325	LF	\$475.00	\$154,375
28	New Conveyance Pipe (60-inch)	900	LF	\$500.00	\$450,000
29	Remove Existing 48-inch RCP	212	LF	\$30.00	\$6,360
30	Backfill, Fine Grading, and Compaction	2,800	CY	\$25.00	\$70,000
<b>SUBTOTAL</b>					<b>\$4,533,410</b>
31	Mobilization/Demobilization (5% of Subtotal)				\$226,671
32	Estimating Contingency (25% of Subtotal)				\$1,133,353
<b>TOTAL COST</b>					<b>\$5,893,433</b>
Notes:					
1	This is an estimate only. These figures are supplied as a guide. Tetra Tech is not responsible for fluctuation in cost of material, labor or components, or unforeseen contingencies.				
2	Estimated costs provided for construction bid items only. For example, estimates for materials testing, staking, and construction management are not included.				
3	Unit costs are based on Caltrans historical cost data and RS Means 2008 cost data where available. The costs are approximately adjusted to 2018 dollars based on the Caltrans Construction Cost Index and RS Means Historical Cost Indexes, respectively.				

### 4.3.2 Implementation Costs

Project implementation costs include all the necessary items to provide a finished product. Costs include feasibility study, preliminary design, final design, environmental documentation and permitting, construction management, construction, and post construction work. The estimated project delivery costs are typically based on a percentage of the construction cost for predesign, design, and construction management. The project implementation subtotal and total capital construction cost is provided in **Table 6**.

**Table 6.** Total Project Cost

Item Description	Cost
Feasibility Study (15% of Construction)	\$884,015
Preliminary Design (3.5% of Construction)	\$206,270
Final Design (10% of Construction)	\$589,343
Environmental Documentation & Permitting	\$176,800
Construction Management (10% of Construction)	\$589,343
<b>SUBTOTAL</b>	<b>\$2,445,771</b>
Construction Cost	\$5,893,433
<b>Capital Cost TOTAL</b>	<b>\$8,330,204</b>

### 4.3.3 Operations & Maintenance Cost

The operations and maintenance cost estimates were developed on the basis that a service contractor would maintain the various components of the system. Operation of the system during wet weather and dry weather events will be managed by the City. Operations of the diversion structure will incorporate coordination and notifications to the Los Angeles County Flood Control District to ensure that there will be no effect to the flood control conveyance system operation. **Table 7** estimates annual costs for typical operations and maintenance activities, not including the cost of long-term monitoring.

**Table 7.** Annual Estimated Operations & Maintenance Costs

Description	Frequency	No. of Times per Year	Unit Price	Total
<b>Diversion</b>				
Rubber Dam System – Inspection and Cleaning	Monthly	12	\$750	\$9,000
Remove Accumulated Trash and Debris in the Basin and Trash Rack at Diversion	Semi-annually	2	\$500	\$100
Inspect Sediment Basin for Sediment Accumulation and Trash/Debris	Semi-annually	2	\$250	\$500
Remove Accumulated Trash and Debris in the Sediment Basin	Semi-annually	2	\$500	\$1,000

Arcadia Arboretum Natural Treatment and Groundwater Recharge Project

Remove Accumulated Sediment in the Forebay and Regrade	Every 5 Years	n/a	\$15,000	\$3,000
<b>Storage</b>				
Trim Vegetation at the Beginning of Wet Season	Annually	1	\$5,000	\$5,000
Inspect Health of Wetlands Vegetation	Monthly	12	\$750	\$9,000
Dry Season Irrigation for Wetlands	Half of the Year	6	\$2,000	\$12,000
<b>Pump Station</b>				
Dry Season Inspection and Cleaning (Vacuum)	Every Other Month	6	\$500	\$3,000
Wet Season Inspection and Cleaning (Vacuum)	Every Other Month	6	\$500	\$3,000
Electrical Usage	Monthly	12	\$460	\$5,520
Valve Maintenance	As-needed	1	\$1,000	\$1,000
Control Panel Maintenance	As-needed	1	\$1,000	\$1,000
Pump Replacement	Every 20 years	n/a	\$25,500	\$1,275
<b>TOTAL</b>				<b>\$53,395</b>

**EXHIBIT B.1.1 SITE PLAN**

CITY OF ARCADIA, CITY OF SIERRA MADRE, AND THE COUNTY OF LOS ANGELES  
**ARCADIA ARBORETUM NATURAL TREATMENT AND GROUNDWATER RECHARGE PROJECT**

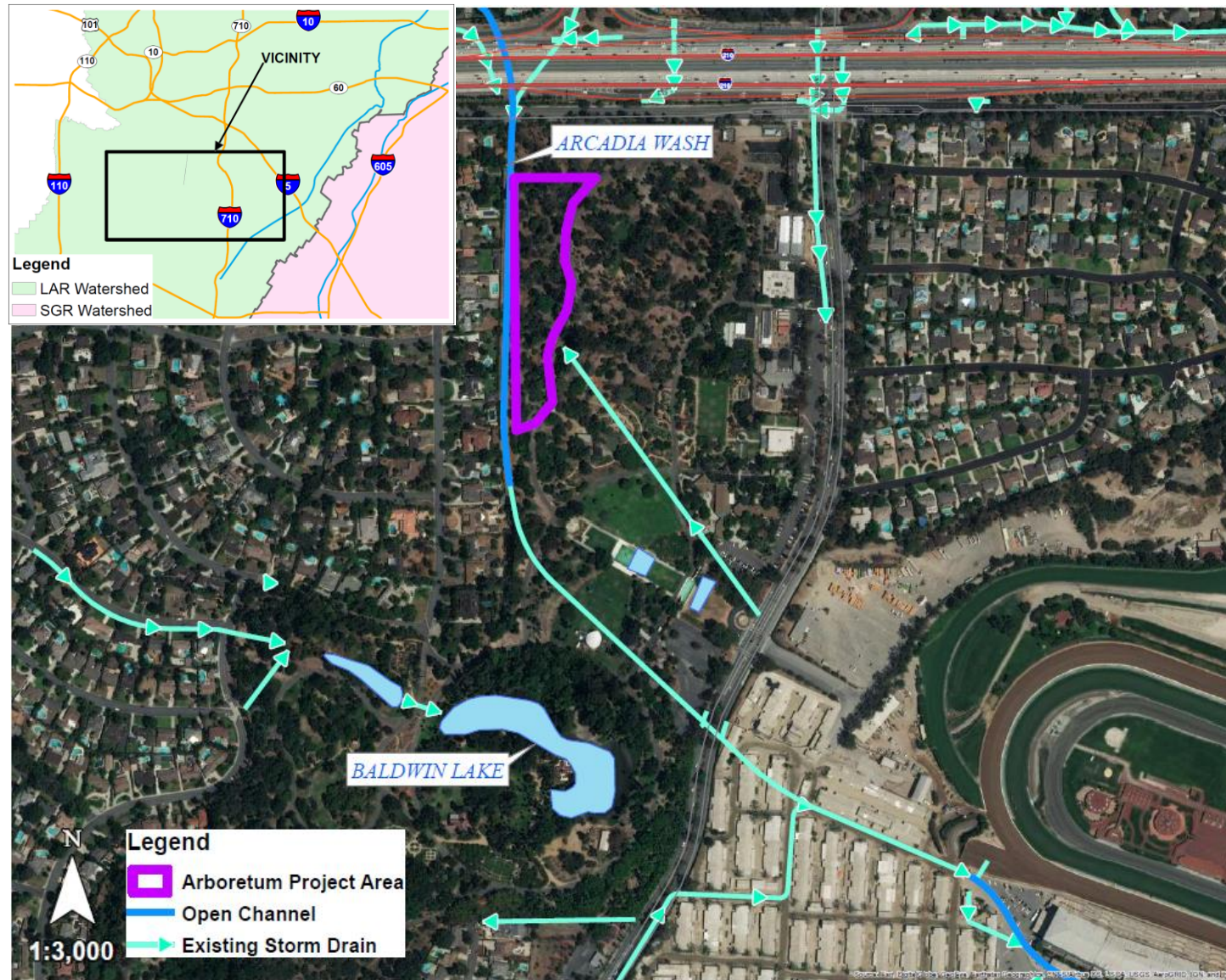


**PLAN VIEW**  
 (See Fact Sheet for Additional Details)

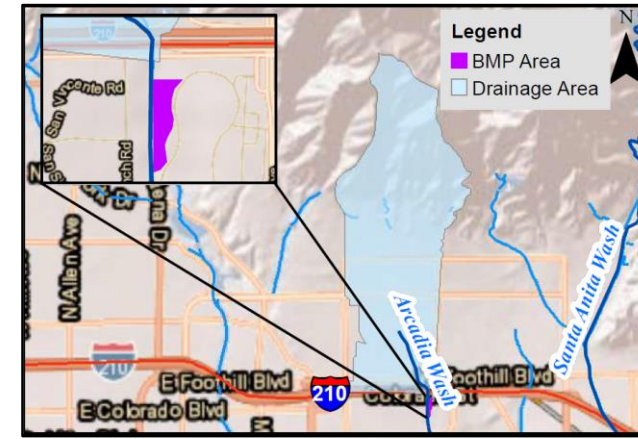


**EXHIBIT B.1.2 FACT SHEET**

**EXISTING SITE CONDITIONS**



**DRAINAGE AREA**



**DRAINAGE CHARACTERISTICS**

DRAINAGE AREA (acres)	1,633
HYDROLOGIC SOIL GROUP	A/B
APPROX. DEPTH TO GROUNDWATER (ft)	58.9
SOIL DESCRIPTION	Well-drained
MODELED AVERAGE ANNUAL RUNOFF VOLUME (ac-ft)	1,633

**BMP CHARACTERISTICS**

LOCATION: ARCADIA ARBORETUM

LAT: 34° 8'32.55"N  
 LONG: 118° 3'13.62"W

**Proposed BMP Description:** The proposed project would restore a degraded habitat along a 2,000-ft long section of the Arcadia Wash by constructing adjacent wetland ponds, groundwater (GW) recharge basins, and a meandering stream to Baldwin Lake. The project would consist of a rubber dam diversion structure to convey diverted flows from the Wash to the wetlands, GW recharge basins, and to the stream. The wetland ponds will create an area for native riparian habitat while providing a natural treatment system for the recharge basins to infiltrate into the Raymond GW Basin. Stormwater will also be conveyed to Baldwin Lake via a natural stream to provide additional habitat and sustained water. This project also proposes catch basin reconstruction into green street mechanisms on the 3 drain inlets to Tule Pond. The green streets will be pretreated and conveyed to Baldwin Lake via a new pipe. Tule Pond would then be filled with dirt to be used for planting.

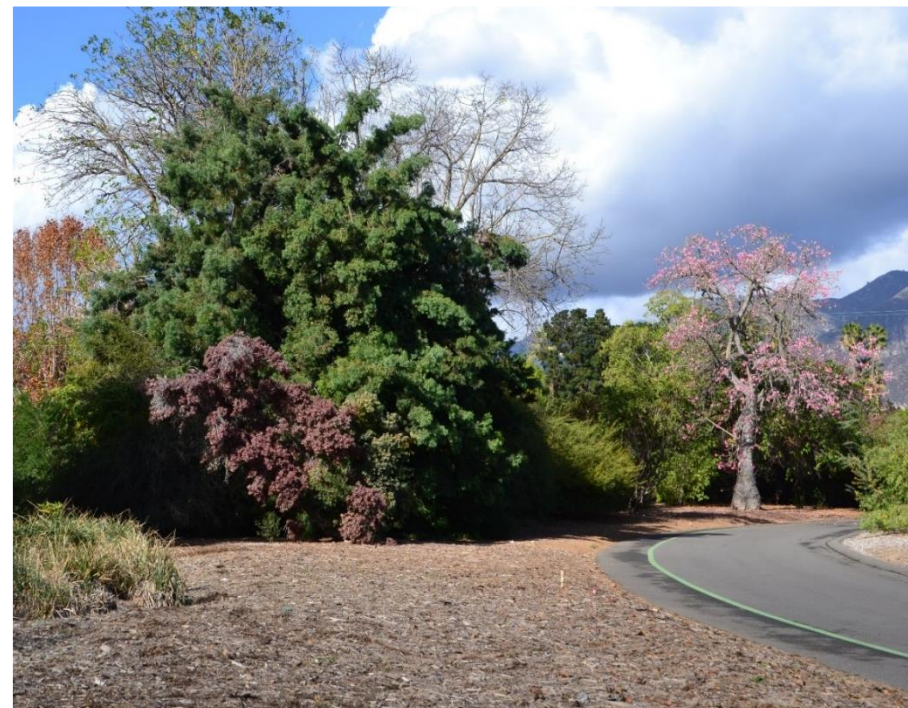
**Project Benefits:**

- Aquatic Ecosystem Restoration with a natural treatment wetlands and meandering stream adjacent to the Arcadia Wash
- Increase habitat value with native/riparian vegetation for migratory birds and other sensitive species located within the area
- GW recharge into the Raymond GW Basin and stormwater capture potential to provide a sustainable water supply for Baldwin Lake
- Water Quality Improvement in Arcadia Wash, which discharges to the LA River

**Arcadia Wash (Corps-Built Channel)**



**Northwest walking path adjacent to Arcadia Wash**



**Baldwin Lake**



**PROPOSED CONCEPTUAL SITE LAYOUT**

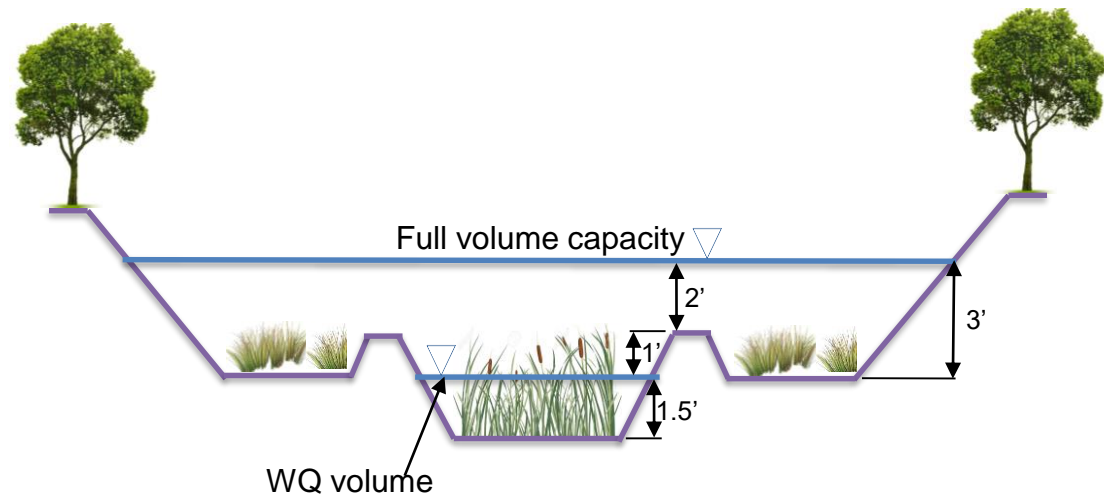


**PLANNING-LEVEL COST ESTIMATE**

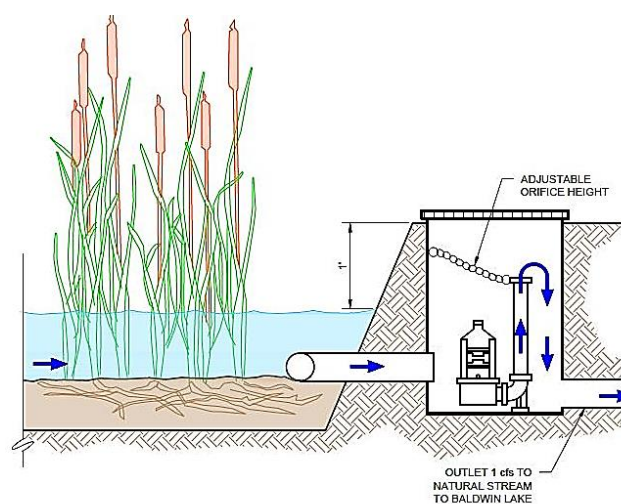
DESCRIPTION	TOTAL COST
Arcadia Wash Diversion, Pretreatment, and Conveyance	\$316,450
Dry Weather Pump Station	\$800,000
Treatment and Recharge Ponds	\$2,565,600
Green Streets for Tule Pond	\$851,360
<b>SUBTOTAL</b>	<b>\$4,533,410</b>
Mobilization/Demobilization (5% of Subtotal)	\$226,671
Estimating Contingency (25% of Subtotal)	\$1,133,353
<b>TOTAL COST</b>	<b>\$5,893,433</b>



**TYPICAL CROSS SECTION**



**WETLAND CROSS SECTION TO OUTLET**



**PROJECT CHARACTERISTICS**

Zinc Reduction Achieved (Note: this project is nested; % Zn reduction contingent upon downstream project)	845 lb/yr (22.4%)
Approx. Arcadia Wash Invert Elevation at Diversion	575.00
Design Diversion Rate	30 cfs
Design In-Stream Flow to Baldwin Lake	1 cfs
Estimated Storage Capacity for Wetland Pond	1.4 ac-ft
Estimate Annual Groundwater Recharge	103.6 ac-ft/yr
Aquatic Ecosystem Restoration Area	0.6 acres

CITY OF ARCADIA, CITY OF SIERRA MADRE, AND THE COUNTY OF LOS ANGELES  
**ARCADIA ARBORETUM NATURAL TREATMENT AND GROUNDWATER RECHARGE FACILITY**





**APPENDIX B.2 RIO HONDO ECOSYSTEM RESTORATION PROJECT AND  
ARCADIA WASH WATER CONSERVATION DIVERSION EVALUATION**

## CONTENTS

---

<b>1.0 SITE DESCRIPTION AND EXISTING HYDROLOGY .....</b>	<b>3</b>
1.1 Arcadia Wash Water Conservation Diversion .....	3
1.2 Rio Hondo Ecosystem Restoration Project.....	5
1.2.1 Land Use Distribution .....	8
1.3 Existing Water Quality.....	8
1.4 Preliminary Geotechnical Findings .....	9
1.4.1 Existing Soil Types .....	9
1.4.2 Ground Water .....	9
1.4.3 Geotechnical Summary .....	10
<b>2.0 BMP DESIGN COMPONENTS .....</b>	<b>10</b>
2.1 Phase 1 – Arcadia Wash Water Conservation Diversion .....	12
2.1.1 Site Layout.....	12
2.1.2 Diversion Structure Analysis.....	13
2.1.3 Pretreatment.....	13
2.1.4 Water Conservation.....	13
2.2 Phase 2 – Rio Hondo Ecosystem Restoration Project .....	14
2.2.1 Site Layout.....	14
2.2.2 Diversion Structure Analysis.....	15
2.2.3 Pretreatment.....	15
2.2.4 Ecosystem Restoration.....	15
<b>3.0 MONITORING PLAN .....</b>	<b>16</b>
3.1 Water Quality Monitoring.....	16
3.1.1 Flow Monitoring Methods .....	17
3.1.2 Composite Sampling Methods .....	17
3.2 Long-Term Performance Monitoring .....	17
<b>4.0 PERMITTING, SCHEDULE, AND COST ESTIMATE .....</b>	<b>17</b>
4.1 Environmental Documents and Permits.....	17
4.1.1 CEQA/NEPA.....	17
4.1.2 Local Construction Permits.....	18
4.2 Schedule .....	19
4.3 Cost Analysis .....	19
4.3.1 Construction Cost .....	19

4.3.2 Implementation Costs ..... 21

4.3.3 Operations & Maintenance Cost ..... 21

**EXHIBIT B.2.1 SITE PLAN ..... 23**

**EXHIBIT B.2.2 FACT SHEET ..... 25**

**EXHIBIT B.2.3 DESKTOP GEOTECHNICAL STUDY ..... 27**

## LIST OF TABLES

---

Table 1. Land Use Distribution Summary .....8

Table 2. Groundwater Wells in the Vicinity of the Site ..... 10

Table 3. BMP Optimization Results ..... 11

Table 4. Project Implementation Schedule ..... 19

Table 5. Construction Cost Estimate ..... 20

Table 6. Total Project Cost ..... 21

Table 7. Annual Estimated Operations & Maintenance Costs ..... 21

## LIST OF FIGURES

---

Figure 1. Arcadia Wash Drainage Map and at Diversion Point .....3

Figure 2. Arcadia Wash Confluence with the Rio Hondo .....4

Figure 3. North Spreading Basin Looking Towards Sawpit Wash Inlet.....5

Figure 4. South Spreading Basin Looking Towards Downstream Rio Hondo.....5

Figure 5. Sawpit Wash at Peck Park Lake .....6

Figure 6. Sawpit Wash Drainage Map at Diversion Point .....6

Figure 7. Rio Hondo Ecosystem Restoration Project & Arcadia Wash Water Conservation Diversion Area of Interest.....7

Figure 8. Cost-Effectiveness Curve for Regional Projects within the Rio Hondo Drainage Area (note that modeled costs are relative – see engineering cost estimated in each appendix) ..... 11

Figure 9. Phase 1 – Arcadia Wash Water Conservation Diversion Site Layout ..... 12

Figure 10. Typical DSBB System ..... 13

Figure 11. Phase 2 – Rio Hondo Ecosystem Restoration Project..... 14

Figure 12. Typical Section and Plan View of Rio Hondo Ecosystem Restoration Wetland ..... 16

## 1.0 SITE DESCRIPTION AND EXISTING HYDROLOGY

### 1.1 ARCADIA WASH WATER CONSERVATION DIVERSION

Arcadia wash is a large concrete channel that collects stormwater runoff from approximately 15,870 acres of the RHSGR WQG jurisdictional area, and is a direct tributary to Rio Hondo Reach 3 (just south of the Peck Road Water Conservation Basins). At the project diversion location, the intersection of Arcadia Wash and Live Oak Avenue, Arcadia Wash has a tributary area of 5,085-acres (**Figure 1**).

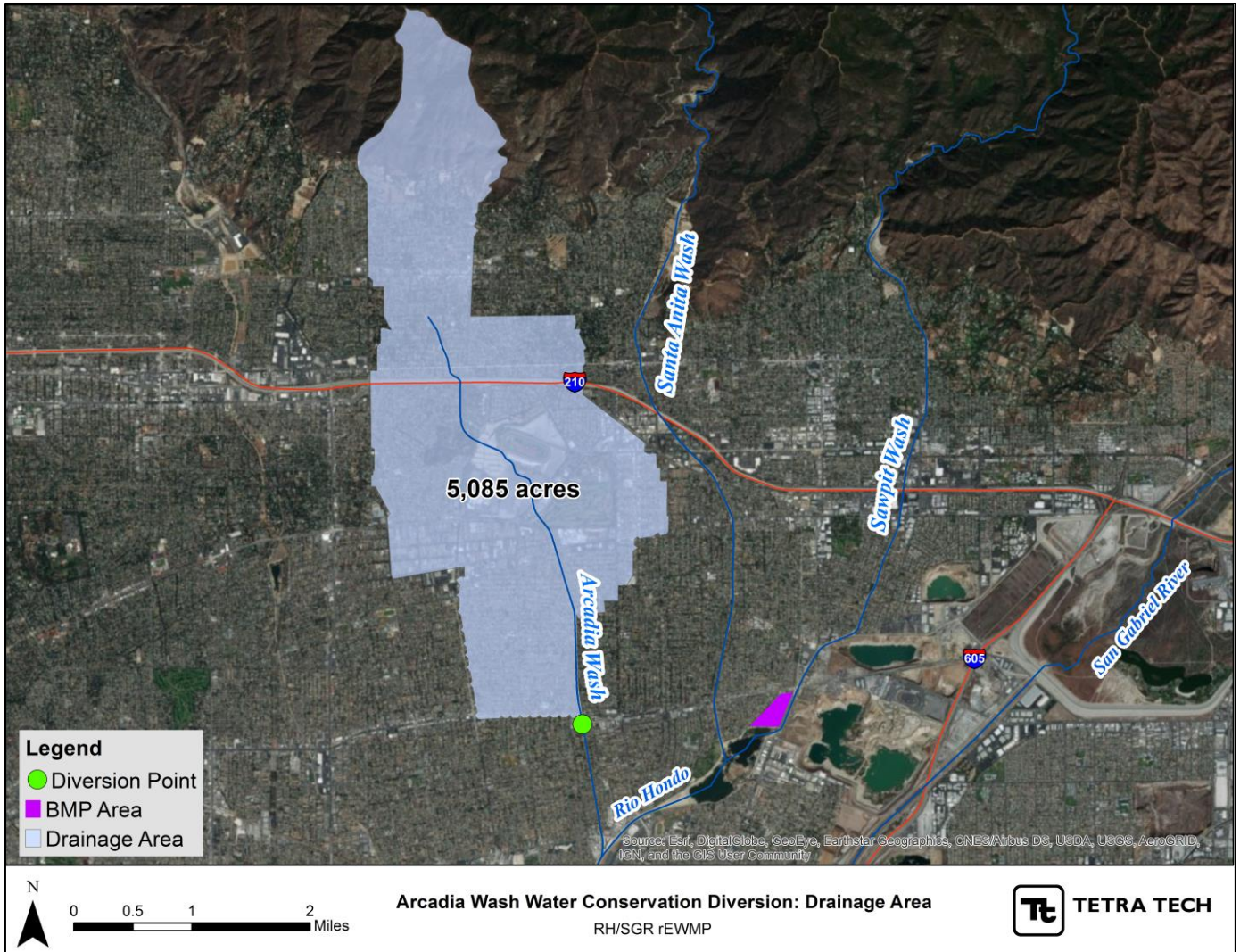


Figure 1. Arcadia Wash Drainage Map and at Diversion Point

The City of Arcadia relies heavily on groundwater, and in the existing condition Arcadia Wash is not providing water quality recharge advantages to the City. See **Figure 2** showing the confluence of Arcadia Wash and the Rio Hondo Channel.



**Figure 2.** Arcadia Wash Confluence with the Rio Hondo

## 1.2 RIO HONDO ECOSYSTEM RESTORATION PROJECT

---

The Peck Road Spreading Basin and Water Conservation Park is approximately 150 acres, located in the southern portion of the cities of Arcadia and Monrovia. Originally constructed as a gravel pit, the Los Angeles County Parks and Recreation Department converted it to a spreading basin and park in 1975. Santa Anita Wash from the west, and Sawpit Wash from the north, are the major tributaries to the spreading basin. Due to the sediment build up at the bottom of the lake, the water collected in the spreading basin recharges the groundwater solely through infiltration into the sidewalls. All flows exceeding what can be infiltrated in the soil drain downstream to Rio Hondo Reach 3. Sediment built up near the Santa Anita Wash outfall has also impacted the way the spreading basin functions, by creating a berm that has naturally separated the basin in two in dry weather (**Figure 3** and **Figure 4**).



**Figure 3.** North Spreading Basin Looking Towards Sawpit Wash Inlet

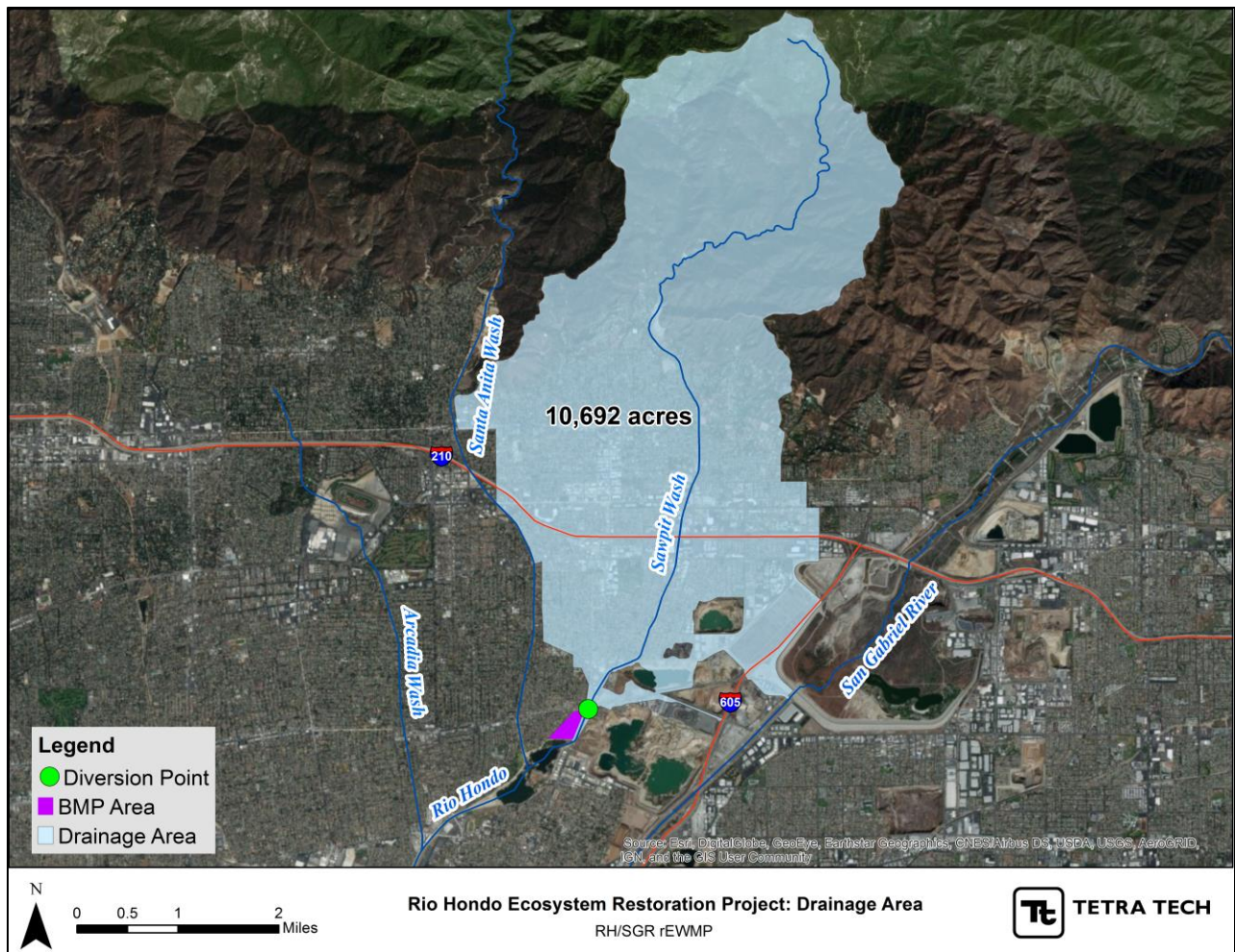


**Figure 4.** South Spreading Basin Looking Towards Downstream Rio Hondo

Sawpit Wash is a Corps built concrete-lined rectangular channel that captures flow beginning at the San Gabriel Mountains, draining through and intercepting flows from the Cities of Arcadia and Monrovia through the upstream storm drain system into the Peck Road Spreading Basin (**Figure 5**). Sawpit Wash has a tributary drainage area of 10,692-acres (**Figure 6**). Much of the drainage area is characterized urban grass and vacant steep slope, which can be attributed to both the composition of area including both the San Gabriel Mountains in the Angeles National Forest as well as the City of Arcadia residential area.



**Figure 5.** Sawpit Wash at Peck Park Lake



**Figure 6.** Sawpit Wash Drainage Map at Diversion Point

Sawpit wash crosses under Peck Road south of its intersection with Live Oak Road. The area of interest for this project are the parcels northeast of the Peck Road Spreading Basin, West of Peck Road, and south of Live Oak Road (**Figure 7**). A historical site assessment was performed as part of the preliminary geotechnical study, which discovered that the location of the proposed treatment facility area is currently occupied by commercial facilities, including a roofing materials company, storage facilities (mini and RV), an unidentified yard, and a vast majority by auto junk yards (Cuenca & Skopek, 3). The area north of the spreading basin and south of the commercial properties slopes down to dense mature trees and vegetation that is being sustained by runoff that drains from Sawpit Wash to the spreading basin.



**Figure 7.** Rio Hondo Ecosystem Restoration Project & Arcadia Wash Water Conservation Diversion Area of Interest



### 1.2.1 Land Use Distribution

Understanding the tributary watershed land use can provide further insight into the best approach to be taken in the water quality assessment. The table provided below characterizes the land use distributions for the entire project based on the Loading Simulation Program utilized in the water quality analysis performed for the feasibility study.

**Table 1.** Land Use Distribution Summary

Land Use	Area (acres)	Percent of Total Area
Agriculture moderate slope D	89.0	1%
Commercial	851.4	6%
HD single-family residential	1025.8	7%
Industrial	636.3	4%
Institutional	396.7	3%
LD single-family residential moderate slope	53.6	0%
LD single-family residential steep slope	13.9	0%
Multifamily residential	549.2	4%
Secondary roads	878.9	6%
Transportation	249.1	2%
Urban grass Irrigated	3769.5	24%
Urban grass Non-irrigated	1331.5	9%
Vacant moderate slope B	21.2	0%
Vacant moderate slope D	92.6	1%
Vacant steep slope B	1888.1	12%
Vacant steep slope C	2746.5	18%
Vacant steep slope D	814.2	5%
Water	43.0	0%

### 1.3 EXISTING WATER QUALITY

For this study, the Los Angeles County Watershed Management Modeling System (WMMS) was used within the LSPC to simulate contaminant loading, runoff volume, and other baseline hydrology parameters. A more detailed description on the watershed modeling methodology and results that informed this feasibility study can be found in the revised Reasonable Assurance Analysis (RAA) in Attachment C of the rEWMP. The results from the revised RAA recommended using the critical water year as the critical condition for compliance, which was 2003 for the Rio Hondo. The limiting priority pollutant used in the water quality analysis based on the existing conditions was zinc.

The Rio Hondo Watershed has a drainage area of 148,183-acres. The Rio Hondo Ecosystem Restoration Project and Arcadia Wash Water Conservation Diversion is one of two regional BMP sites in the overarching feasibility study that is located within the Rio Hondo Watershed.

## 1.4 PRELIMINARY GEOTECHNICAL FINDINGS

---

A desktop evaluation report was performed by Tetra Tech on February 14, 2018. This investigation evaluated the preliminary infiltration feasibility for a groundwater recharge facility as part of the proposed BMP, located southwest of the intersection between Peck Road and Live Oak Avenue in Arcadia. The preliminary geotechnical review provided in the Desktop Geotechnical Study (Tetra Tech 2018; Exhibit B.2.3) includes aerial photography review, subsurface conditions discussion, and seismicity analysis based on the available literature and resources for the site area. This section summarizes the findings from the preliminary evaluation specifically related to the onsite soil types and historic groundwater levels. To ascertain the characteristics of the onsite subsurface materials, a subsurface investigation consisting of soil boring logs and Cone Penetration Tests is recommended by Tetra Tech.

### 1.4.1 Existing Soil Types

Based upon findings from the desktop investigation, the site originally consisted of gravel and sand from major streams, and alluvial fan detritus from the San Gabriel Mountains. From historical site photos it was determined that the site was formerly used for mining, but after the mining, the native excavated alluvial materials were replaced with imported fill. Uncontrolled fills are likely to be looser and potentially have larger voids compared to engineered fills, and thus are considered potentially more suitable for infiltration potential. The nature of this fill material and its degree of compaction is unknown, but the USDA Natural Resource Conservation Service website ([websoilsurvey.sc.egov.usda.gov/App/WebSoilSurvey.aspx](http://websoilsurvey.sc.egov.usda.gov/App/WebSoilSurvey.aspx)) was used to obtain preliminary information regarding the infiltration capacity of the surficial soils. The available maps showed that surficial soils can be described as fine sandy loam. By using the estimated hydraulic conductivity and applying recommended safety factors according to the County of LA Guidelines, equivalent design infiltration rates were calculated as ranging between 0.07 and 0.25 inches/hour, which are lower than the minimum required design infiltration rate. Due to the nature of the site it is likely that a high degree of non-homogeneity of material composition will be found at the site during subsurface testing; therefore, the infiltration rates could vary greatly. It is recommended that several infiltration tests should be performed to accurately describe the soil characteristics and infiltration capabilities.

### 1.4.2 Ground Water

According to the State of California (CDMG, 1999), the historic high groundwater level near the site has been mapped at approximately 14 to 25 feet below the existing grade. This groundwater information is based on last century water well logs as well as the conditions prior to massive redevelopment within the last 50 years, and may not apply to the current conditions. Based on the City of Irwindale's interpretation of the anticipated conditions in the general area, the design groundwater depth is assumed as ranging between 54 and 70 feet deep.

A review of the well data from the LACDPW database (<http://dpw.lacounty.gov/general/wells/>) for nearby wells (less than 0.5 miles from the site) was conducted and indicate groundwater depths as summarized in **Table 2**. As shown, the shallowest groundwater depth was recorded at 42.1 feet in 1969. Based on the well data provided, it can be assumed that the groundwater at the site has been deeper than 42 feet within the last 50 years. These results confirm that the LA County guidelines will be met that require a 10-foot separation between infiltration facilities and the groundwater level. Fluctuations of the groundwater level, localized zones of perched water, and increased soil moisture content should be anticipated during and following the rainy season. Irrigation of landscaped areas on or adjacent to the site can also cause a fluctuation of local groundwater levels. Recharging and water management at the Santa Fe Dam has also been known to influence local groundwater levels (Tetra Tech; 2018). Based on the research and observed conditions, groundwater is not expected to impact the design and construction of the proposed BMP.

**Table 2.** Groundwater Wells in the Vicinity of the Site

Well Identification	Monitoring Period	Approximate Location Relative to the Site	Shallowest Groundwater Depth (within the last 50 years)	Last Measured Depth
State #01S11W11F04 LACDPW Well ID: 4199E	Sept. 1948 to Oct. 2008	0.19 miles to south	42.1 feet on Jun. 1969	215.1 feet on Oct. 2008
State #01S11W11C05 LACDPW Well ID: 4199L	Mar. 1962 to Nov. 2013	0.19 miles to the west	45 feet on Jun. 1969	144 feet on Nov. 2013
State #01S11W10H01 LACDPW Well ID: 4189G	Sept. 1953 to Oct. 2009	0.47 miles to the southwest	48.8 feet on Apr. 1969	137.6 feet on Oct. 2009
State #01S11W02L03 LACDPW Well ID: 4198R	Oct. 1964 to Oct. 2015	0.32 miles to the north	52.5 feet on Jun. 1969	156.5 feet on Oct. 2015
State #01S11W12G01 LACDPW Well ID: 3010D @ Hanson Pit	Aug. 1968 to Oct. 2017	0.5 miles to the east	53.1 feet on May 1969	169 feet on Apr. 2010

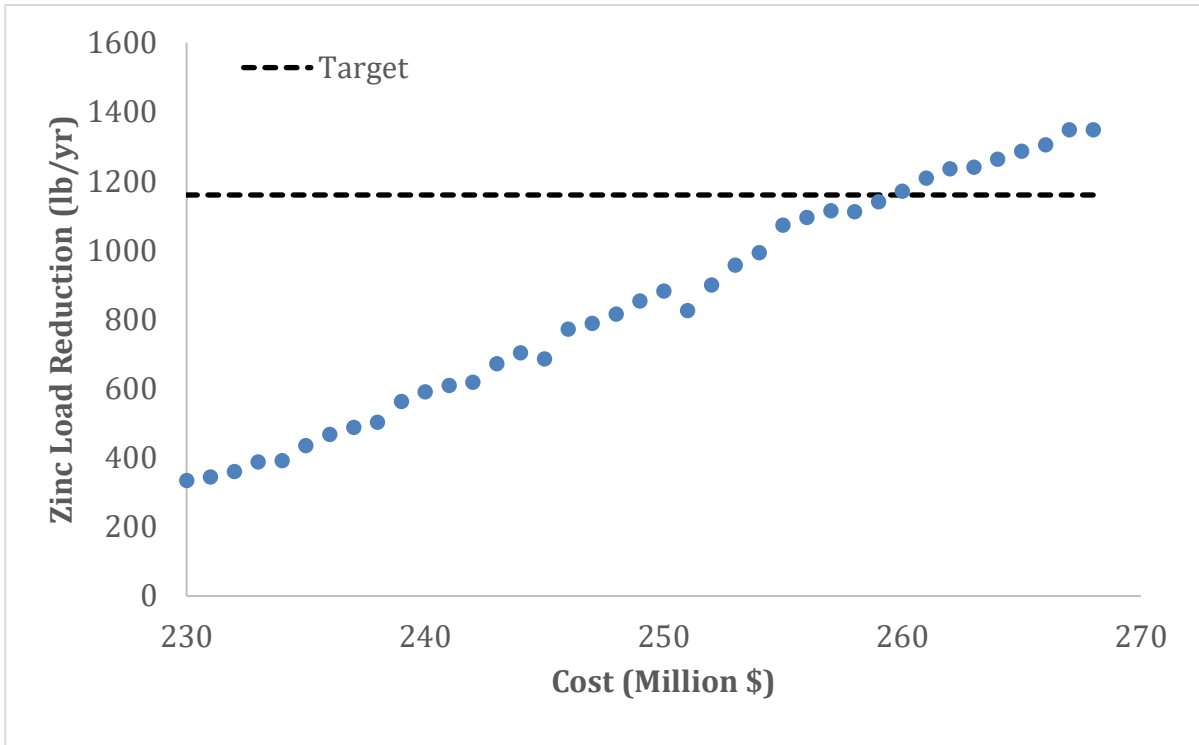
### 1.4.3 Geotechnical Summary

Based on the results of the preliminary desktop evaluation, it is Tetra Tech’s initial opinion that due to the potential presence of uncontrolled fills, this site may be suitable for infiltration potential. However, since the in-situ materials remain unknown, it is expected that that subsurface infiltration testing be performed according to the LA County infiltration criteria at the design stage of this project to verify assumptions. Additional conclusions and results from the geotechnical evaluation can be found in Exhibit B.2.3.

## 2.0 BMP DESIGN COMPONENTS

The optimum BMP footprint and diversion rate was determined for the BMP site based on the long-term average annual zinc reduction, simulated using the EPA System for Urban Stormwater Treatment and Analysis Integration (SUSTAIN) model. To optimize the selection and placement of BMPs, SUSTAIN iteratively runs different combinations of BMP properties, varied within a specified range, to generate a cost-effectiveness curve (**Figure 8**). These curves show the additional load reductions from potential multi-benefit regional project configurations, beyond that already achieved from redevelopment projects and MCMs. The recommended BMP sizes and diversion rates to BMPs are based on the most cost-effective scenario.

The annual critical condition for load reduction requirements was determined by comparing the average rainfall within a ten-year period (2002-2011) that was closest to the 90<sup>th</sup> percentile average rainfall. The runoff treated by the BMP was then simulated over this ten-year period using critical water year determined for the Rio Hondo Watershed as 2003. Configurations of the multi-benefit regional projects which meet the required load reductions and exhibit the maximum performance for the given cost were reviewed and the recommended configuration is presented below (**Table 3**). Since the BMP optimization for Rio Hondo Watershed is based on all tributary BMPs, the achieved load reduction and cost presented below are associated with the implementation of both this project and the upstream Arcadia Arboretum Natural Treatment and Groundwater Recharge Project.



**Figure 8.** Cost-Effectiveness Curve for Regional Projects within the Rio Hondo Drainage Area (note that modeled costs are relative – see engineering cost estimated in each appendix)

**Table 3.** BMP Optimization Results

Parameter	Rio Hondo Wetland
Length (ft)	2400
Width (ft)	150
Height (ft)	4
BMP Capacity (ac-ft)	26.9
Diversion Rate (cfs)	185 (Sawpit Wash) + 37 (Arcadia Wash)
Zinc Load Reduction (lbs/yr)	818.3 (21.4%)
• Phase 1	468.4
• Phase 2	349.9

**Notes:**

- Existing Wet Days Zn Load for the Rio Hondo was 3,822 lbs/yr.
- Phase 2 zinc load reduction is dependent on the construction of the upstream Arcadia Arboretum Ecosystem Restoration and Groundwater Recharge Project.

## 2.1 PHASE 1 – ARCADIA WASH WATER CONSERVATION DIVERSION

Phase 1 of this Regional BMP System will focus on water conservation efforts for Arcadia Wash to recharge water into the San Gabriel Groundwater Basin. This phase will not only provide water conservation benefits by recharging flow from Arcadia Wash, but will also provide incidental water quality benefits to help meet the 50% milestone for the LA River Metals TMDL. Phase 1 of this project is primarily a water conservation project, and is considered an update to the baseline watershed model rather than a standalone water quality BMP.

### 2.1.1 Site Layout

Runoff from Arcadia Wash will be diverted to a pretreatment device at the intersection of Live Oak Avenue and conveyed approximately 10,000 to the east to Sawpit Wash. The flows will be conveyed via gravity until passing Santa Anita Wash, at which point a pump station will be used to lift the flows for continued gravity flow to Sawpit Wash. The site layout highlighting Phase 1 is shown in **Figure 9** and can also be found in Exhibit B.2.1.



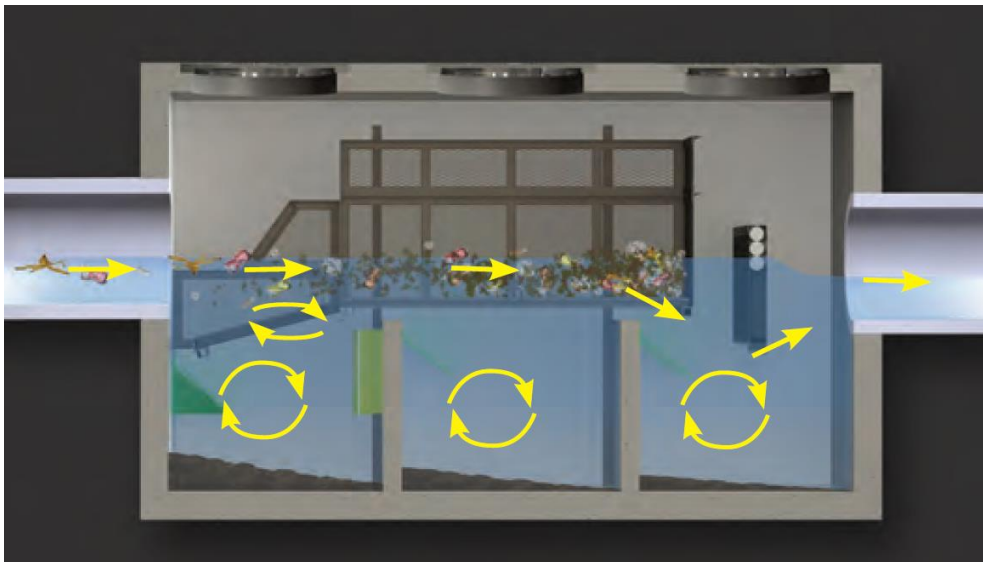
**Figure 9.** Phase 1 – Arcadia Wash Water Conservation Diversion Site Layout

### 2.1.2 Diversion Structure Analysis

The optimal flow rate determined from the water quality analysis was 37cfs. A grated drop inlet diversion will be constructed in Arcadia Wash to convey flow to a pretreatment unit then to Sawpit Wash by a 30-inch RCP. Approximately 4,000 feet of pipe will gravity flow under Live Oak Avenue from Arcadia Wash to Santa Anita Wash. Near the intersection of Santa Anita Wash and Live Oak Avenue a pump station will be constructed to lift the diverted flows to a normal storm drain depth (approximately between 4 and 6 feet below finished surface) for continued gravity flow conveyance the remaining 6,000 feet to Sawpit Wash. Property acquisition will be required for constructing the pump station. The sidewall of Sawpit Wash will need to be reconstructed for a 36-inch pipe inlet.

### 2.1.3 Pretreatment

Stormwater runoff transports sediment, trash, and debris that can compromise the performance of stormwater facilities and pollute receiving waters. Pretreatment will be an integral component of the treatment strategies to extend the life of the proposed systems. Pretreatment is recommended in order to reduce the maintenance frequency of the BMP site stormwater facilities and to focus maintenance efforts to a concentrated area. A Debris Separating Baffle Box (DSBB) by BioClean Environmental Services is proposed as the pretreatment solution for the Arcadia Wash diversion. With a diversion rate of 37 cfs, a DSBB-8-12 would be required based on their product specifications. The NSBB system uses screens that are suspended above the sedimentation chambers that capture and store trash and debris in a dry state, thus reducing potential nutrient leaching and bacteria growth. TSS is removed by routing the flows through a triple chambered system. An oil skimmer with hydrocarbon booms traps and absorbs oil. The NSBB system can remove more than 80 percent of TSS. **Figure 10** illustrates the typical operation of a DSBB system.



**Figure 10.** Typical DSBB System

Source: BioClean Environmental, Inc.

### 2.1.4 Water Conservation

Currently Arcadia Wash is not providing groundwater recharge benefits to the City of Arcadia because of its confluence location with the Rio Hondo south of the Peck Road Water Conservation Basin. By diverting flows from Arcadia Wash to Sawpit Wash, this water will now be routed to the Peck Road Water Conservation to provide increased volume for recharge into the Groundwater Basin.

## 2.2 PHASE 2 – RIO HONDO ECOSYSTEM RESTORATION PROJECT

Phase 2 of this project is where the majority of the regional water quality benefits will be achieved. This phase combines the water conservation benefits from Phase 1 with the additional pollutant load reduction and habitat restoration benefits provided by a constructed wetland. This project will also provide a natural treatment system to the downstream spreading basin at Peck Park. A temporary inundation area adjacent to the wetland will allow for groundwater recharge as well.

### 2.2.1 Site Layout

Phase 2 of this project will divert runoff from Sawpit Wash (and the Phase 1 Arcadia wash flows) to convey stormwater flows to sediment basin before entering an 8.3-acre constructed wetlands habitat with adjacent groundwater recharge basins prior to discharge into the Peck Road Water Conservation basins and to the downstream Rio Hondo Channel. The site layout highlighting Phase 2 is shown in **Figure 11** and can also be found in Exhibit B.2.1.



Figure 11. Phase 2 – Rio Hondo Ecosystem Restoration Project

## 2.2.2 Diversion Structure Analysis

The optimal flow rate determined from the water quality analysis was 185cfs. A grated drop inlet diversion will be constructed in Sawpit Wash (downstream of the Arcadia Wash diversion inlet) to convey flow to a sediment basin at the northern end of the project area by a 60-inch RCP. Approximately 350 feet of pipe will be constructed in Peck Road to gravity flow to the northeast corner of the project area, near the intersection of Live Oak Avenue and Peck Road. The commercial properties this project is proposed on will need to be acquired for the construction of this BMP. Depending on soil infiltration rates and additional details that will be determined in the design stage, the 21-acre parcel along the left half of the project area may only need to be acquired, in which right-of-way would need to be acquired through the northeastern parcel for storm drain construction and conveyance purposes. For gravity flow to be feasible for this diversion, excavation of the proposed site to depths of approximately  $\pm 20$  feet will be required.

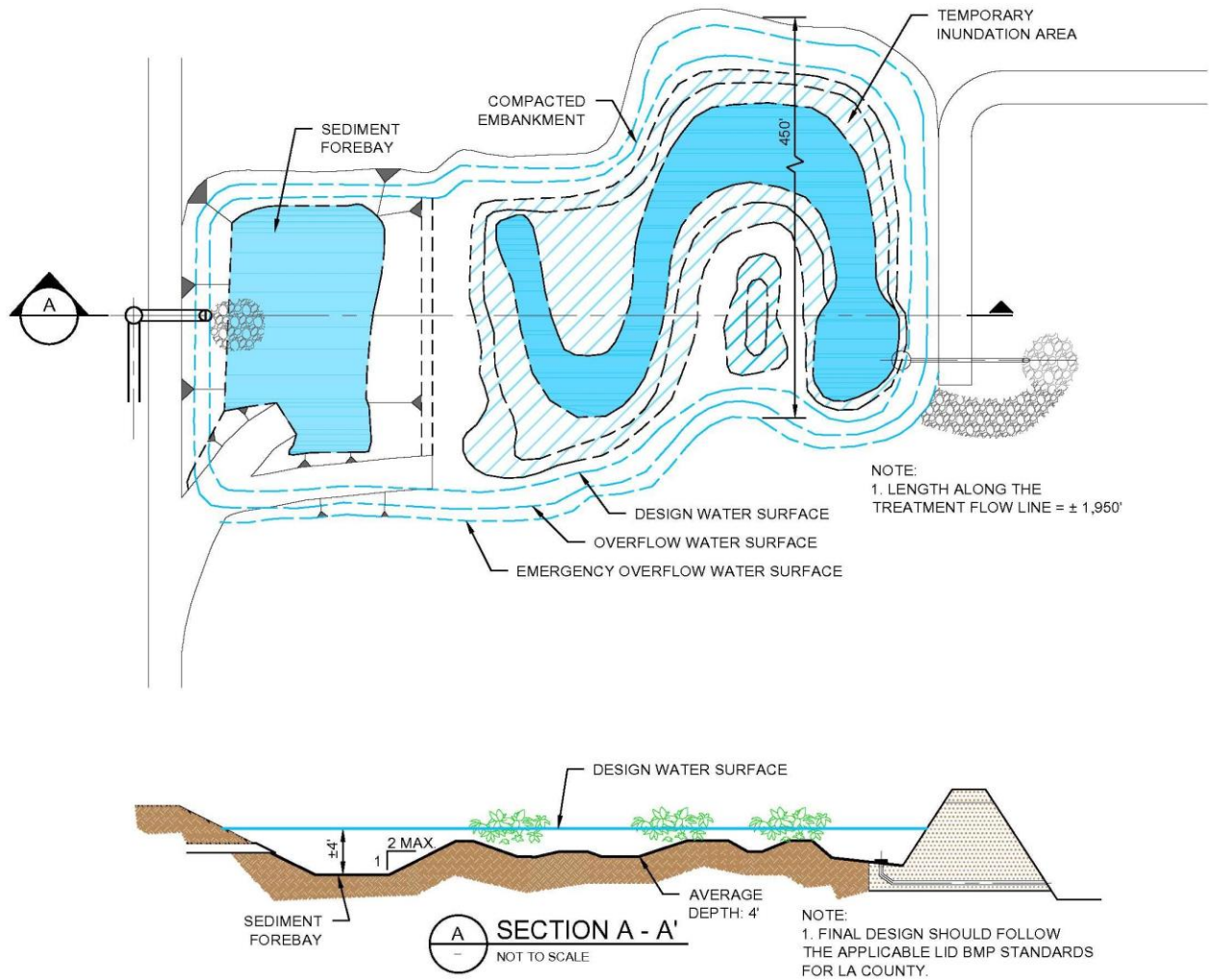
## 2.2.3 Pretreatment

As stated in the Phase 1 discussion, pretreatment is an integral component of the treatment strategies to extend the life of the proposed systems and is recommended in order to reduce the maintenance frequency and concentrate the maintenance efforts of the BMP site stormwater facility. The pretreatment method proposed for the Rio Hondo Ecosystem Restoration Project is a sediment forebay upstream of the BMP facility. The sediment basin will allow isolate gross sediments prior to entering the wetland. The forebay should be sized to contain approximately 3.3 ac-ft of volume (10% of the wetland volume). The sediment basin will increase the residence time, which will help settle coarse sediment particles and improve pollutant removal.

## 2.2.4 Ecosystem Restoration

The wetland is the primary means of regional treatment for this site. According to California Stormwater Quality Association's (CASQA) BMP Handbook, constructed wetlands are constructed basins that have a permanent pool of water throughout the year (or at least during the wet season) and are shallow in depth with vegetation cover on the bottom. As stormwater flows through the wetland, pollutant removal is achieved through settling and biological uptake within the wetlands. Specific plants are chosen that will effectively remove nutrients and dissolved pollutants from the stormwater through the root systems of the vegetation. The constructed wetland for this project will vary in depth as it meanders to the outlet (minimum 1% longitudinal slope), with an average depth of 4 feet. A ponding area will be constructed on both sides of the wetland before sloping up to meet the existing grade. Incorporating the adjacent ponding area into the design will allow for the wetland and ponding area to experience short periods of temporary inundation as the ponding infiltrates and recharges a larger stormwater capacity. The recharge ponds will fill with water and infiltrate into the San Gabriel Groundwater Basin, providing approximately 1,000 ac-ft/yr of recharge. This system is designed to drain the inundated area within a maximum 72-hour period to sustain the health of the wetland vegetation by avoiding extended periods of flooding. At the downstream end of the wetland there will be a spillway pipe connection to the Peck Road Water Conservations Basin. A plan view and cross section detail has been provided in **Figure 12**.





**Figure 12.** Typical Section and Plan View of Rio Hondo Ecosystem Restoration Wetland

### 3.0 MONITORING PLAN

There are two goals of a monitoring plan: 1) water quality monitoring to document the performance of the BMP and to demonstrate compliance with the EMWP, and 2) long-term monitoring to maintain and track performance and predict required maintenance.

#### 3.1 WATER QUALITY MONITORING

To verify the performance of the regional structural BMPs, flow weighted composite samples should be collected at the inlet and the outlet of the system. The exact monitoring locations will be determined upon further project implementation. At minimum, the samples should be analyzed for Zinc. It is recommended that analysis include all priority pollutants identified in the RH/SGR Coordinated Integrated Monitoring Program (CIMP).

### 3.1.1 Flow Monitoring Methods

Flow at the BMP inlet location should be measured at pre-programmed intervals using an area-velocity bubbler (AVB) flow meter with an AVB sensor. Flow at the outlet should be measured using a Thel-Mar volumetric compound weir, which is capable of measuring low flows with a high degree of accuracy. A bubbler flow meter is recommended to measure flow depth behind the rubber dam in wet weather, which is then converted to a flow rate by the flow meter. The flow meter will continuously log the flow measurements at regular intervals during monitoring events.

### 3.1.2 Composite Sampling Methods

A flow-weighted composite sample is comprised of a series of sample aliquots collected over the course of a storm event where the sample aliquot frequency is determined by a constant incremental flow volume measured by the flow meter. To collect the sample, a flow meter is pre-programmed with a pacing volume. When the accumulated flow reaches the pacing volume, the flow meter will trigger an automated sampler to collect a sample aliquot. This process continues until the storm ends. The pacing volume is determined by storm event forecast and the anticipated total volume of runoff. Ideally, pacing volumes will be set to fill one composite bottle for the duration of rainfall to ensure sufficient sample volume for all analyses; however, stormwater runoff durations may be shorter or longer (or the rainfall intensity may be less or greater) than anticipated. If the rainfall duration is longer than that predicted, additional clean, empty bottles may be added to the sampling system. The automated sampler should log the sample information during the course of the monitoring event.

## 3.2 LONG-TERM PERFORMANCE MONITORING

---

Additional monitoring equipment, including water level meters and soil moisture sensors, are recommended to monitor and track the long-term performance of the regional structural BMPs. A continuous monitoring system can provide significant insight into the current and long-term performance of the BMP. A water level logger at the surface of the soil media can collect data on the ponding depth and ultimately determine the infiltration rate at the surface. This data can be used to determine the performance throughout a rain event and demonstrate any decreases in performance from the start of the rain event to the end; an overall reduction in infiltration could indicate an impending maintenance need allowing staff to predict when maintenance will be required rather than reacting to a visual indicator. A soil moisture sensor strategically placed in the BMP could also indicate if the system is performing as designed and identify any potential performance limitations.

## 4.0 PERMITTING, SCHEDULE, AND COST ESTIMATE

A preliminary cost estimate and schedule has been created to give the EWMP group an idea of the funds that will need to be secured to construct this regional BMP facility as well as validate that the BMP site will meet milestones set forth in the EWMP.

### 4.1 ENVIRONMENTAL DOCUMENTS AND PERMITS

---

Consultation with regulatory agencies and acquisition of permits is required before the project components can be constructed. The following sections summarize regulatory permits and approvals relevant to the project.

#### 4.1.1 CEQA/NEPA

A governmental agency is required to comply with California Environmental Quality Act (CEQA) procedures when the agency proposes to carry out or approve the activity/project. CEQA considers a “project” to be the whole of an action, which has a potential for resulting in either a direct physical change in the environment, or a reasonably foreseeable indirect physical change in the environment. The preparation of an Initial Study (IS) is typically the

first step for projects determined not to be exempt from CEQA requirements. Initial Studies allow decision-makers the opportunity to review a proposed project and to make an environmental determination recommending the follow-on CEQA document. Initial Studies consider all phases of project planning, implementation, and operation and utilize the CEQA Guidelines IS Checklist form that covers 17 environmental resources topics. If the IS identifies that there is no substantial evidence that the project may have a significant impact on the environment (without or with mitigation) then a Negative Declaration (ND) or Mitigated Negative Declaration (MND) may be prepared. In the unlikely event the IS identifies that the project may have a significant impact on the environment, then an Environmental Impact Report (EIR) would be required. A description of investigations that may be required are included below.

Compliance with the National Environmental Policy Act (NEPA) would be required if there is a federal nexus (such as federal funding). In addition, the project will need to comply with the implementing procedures of the applicable federal agency.

#### **4.1.1.1 Historical Resources**

The Historical Resources assessment will investigate the occurrence of historically significant areas within the vicinity of a proposed project site, namely sites listed on or eligible for designation by the California Register of Historical Resources (CRHR). A resource should be considered a historical resource if it has previously been identified as significant in a historical resources survey.

If a Lead Agency is unsure about a resource, they should consider hiring a professional historian or archeologist who meets the Secretary of the Interior Standards Professional Qualifications for History, Architectural History, or Archeology. However, CEQA ultimately delegates final authority to the Lead Agency to determine if a resource is historically significant or not (CEQA Case Studies).

Similar projects within recent years to the submission of this report have identified historical wheat farms from the 1870s and shipper centers from the 1920s, which had no official historical designations.

#### **4.1.1.2 Archaeological Resources**

Investigations by institutions such as The Native American Heritage Commission's search of the Sacred Lands Inventory will likely be required for full compliance. Further assessments for isolated artifacts or stream or topographical formations may also indicate the presence of subsurface prehistoric archaeological resources during excavation.

#### **4.1.1.3 Paleontological Resources**

Paleontological records may be assessed for records of known vertebrate fossils within the proposed project areas, as well as within older, sedimentary deposits.

#### **4.1.1.4 Burial Sites**

An investigation of known burial sites will occur prior to construction. In the event that an unknown burial site or human remains are found during excavation, mitigation should be implemented so that potential impacts remain at a less than significant level.

### **4.1.2 Local Construction Permits**

The City of Monrovia may require building and grading permits for construction of this design. Traffic control will play an integral role in construction of the facility and the impacts of hauling export soils from the project during the excavation phase.

## 4.2 SCHEDULE

An estimated project schedule is outlined in **Table 4**. The feasibility study will accomplish 10% level design. The design task includes predesign (30-60% design level) and final design (60-100% design).

**Table 4.** Project Implementation Schedule

Task	PHASE 1 Start	PHASE 1 Finish	PHASE 2 Start	PHASE 2 Finish
Feasibility Study	1/11/2021	7/11/2021	7/11/2023	7/11/2024
Design	7/11/2021	1/11/2022	7/11/2024	7/11/2025
Environmental Documentation (IS/MND) & Permitting	7/11/2021	7/11/2022	7/11/2024	7/11/2025
Bid & Award	7/11/2022	1/11/2023	7/11/2025	1/11/2026
Construction	1/11/2023	1/11/2024	1/11/2026	1/11/2028

## 4.3 COST ANALYSIS

The cost analysis is utilized as a tool to ensure the preliminary design is within the amount of funds available to the project. If the cost analysis indicates that the project is not feasible, then the design will need to be adjusted to bring it within the project budget, while still meeting the project goals. The cost analysis was developed using various sources of information, as well as the Cost Estimator’s judgement. Costs do not include property acquisition. A summary of the total costs will be provided after the construction and implementation cost discussion.

### 4.3.1 Construction Cost

The construction costs entail various components of the projects that a Contractor would construct for the City. Construction costs do not include items of work not directly performed by the Contractor, such as a City’s construction management during construction. The construction costs were developed using various source of cost information. Unit costs were based on Caltrans historical data and RSMeans cost data. All costs were approximately adjusted to 2018 dollars based respectively on the Caltrans Construction Cost Index and RSMeans Historical Cost Index. The estimated capital construction costs for the proposed BMP are listed in **Table 5**.

**Table 5. Construction Cost Estimate**

ITEM NO	DESCRIPTION	QUANTITY	UNIT	UNIT PRICE	TOTAL
<b>PHASE 1 - Arcadia Wash Water Conservation Diversion</b>					
<b>Arcadia Wash Diversion, Pretreatment, and Conveyance</b>					<b>\$5,997,500</b>
1	Rubber Dam Diversion	1	EA	\$120,000.00	\$120,000
2	Pretreatment Device (39 CFS)	1	EA	\$150,000.00	\$150,000
3	Piping to Pretreatment (36" RCP)	20	LF	\$375.00	\$7,500
4	Piping to Sawpit Diversion Pipe (36" RCP)	10,000	LF	\$375.00	\$3,750,000
5	Excavation for Conveyance Pipe	6,000	CY	\$45.00	\$270,000
6	Pump Station	1	LS	\$1,100,000.00	\$1,100,000
7	Electrical Service, Controls, and Instrumentation	1	LS	\$600,000.00	\$600,000
<b>Estimated Land Acquisition</b>					<b>\$1,390,000</b>
8	Land for Pump House Structure	1	EA	1,390,000	\$1,390,000
<b>Phase 1 Subtotal</b>					<b>\$7,387,500</b>
9	Mobilization/Demobilization (5% of Subtotal)				\$147,750
10	Estimating Contingency (25% of Subtotal)				\$1,846,875
<b>Phase 1 Total Cost</b>					<b>\$9,382,125</b>
<b>PHASE 2 - Rio Hondo Ecosystem Restoration Project</b>					
<b>Sawpit Wash Diversion, Pretreatment, and Conveyance</b>					<b>\$16,789,000</b>
11	Rubber Dam Diversion	1	EA	\$150,000.00	\$150,000
12	Active Control System	1	EA	\$75,000.00	\$75,000
13	Diversion Structure	1	EA	\$60,000.00	\$60,000
14	Trash Rack for Diversion	1	EA	\$4,000.00	\$4,000
15	Piping to Wetland (60" RCP)	300	LF	\$500.00	\$150,000
16	Excavation for Conveyance Pipe	6,500	CY	\$45.00	\$292,500
17	Sediment Basin Excavation & Hauling	356,500	CY	\$45.00	\$16,042,500
18	Rip Rap Energy Dissipaters	30	TON	\$500.00	\$15,000
<b>Storage &amp; Treatment</b>					<b>\$17,536,400</b>
19	Bioswale Soil Media	21,700	CY	\$50.00	\$1,085,000
20	Drainage Rock	10,800	CY	\$58.00	\$626,400
21	Planting & Plant Establishment	292,500	SF	\$4.00	\$1,170,000
22	Excavation for Wetlands	325,000	CY	\$15.00	\$4,875,000
23	Hauling	325,000	CY	\$30.00	\$9,750,000
24	Overflow Structure	1	EA	\$30,000.00	\$30,000
<b>Estimated Land Acquisition</b>					<b>\$3,030,000</b>
25	Land for Wetlands	1	EA	3,030,000	\$3,030,000
<b>Phase 2 Subtotal</b>					<b>\$37,355,400</b>
26	Mobilization/Demobilization (5% of Subtotal)				\$1,867,770
27	Estimating Contingency (25% of Subtotal)				\$9,338,850
<b>Phase 2 Total Cost</b>					<b>\$48,562,020</b>
<b>TOTAL COST</b>					<b>\$57,944,145</b>

Notes:

- 1 This is an estimate only. These figures are supplied as a guide. Tetra Tech is not responsible for fluctuation in cost of material, labor or components, or unforeseen contingencies.
- 2 Estimate does not include surface (non-water quality) features.
- 3 The land acquisition costs were estimated from the LA Property Assessment Information 2017 Roll Values.
- 4 Estimated costs provided for construction bid items only. For example, estimates for materials testing, staking, and construction management are not included.
- 5 Unit costs are based on Caltrans historical cost data and RS Means 2008 cost data where available. The costs are approximately adjusted to 2018 dollars based on the Caltrans Construction Cost Index and RS Means Historical Cost Indexes, respectively.

### 4.3.2 Implementation Costs

Project implementation costs include all the necessary items to provide a finished product. Costs include feasibility study, preliminary design, final design, environmental documentation and permitting, construction management, construction, and post construction work. The estimated project delivery costs are typically based on a percentage of the construction cost for predesign, design, and construction management. The project implementation subtotal and total capital construction cost is provided in **Table 6**.

**Table 6.** Total Project Cost

Item Description	Cost
Feasibility Study (15% of Construction)	\$8,691,622
Preliminary Design (3.5% of Construction)	\$2,028,045
Final Design (10% of Construction)	\$5,794,415
Environmental Documentation & Permitting	\$580,000
Construction Management (10% of Construction)	\$5,794,415
<b>SUBTOTAL</b>	<b>\$22,888,497</b>
Construction Cost	\$57,944,145
<b>Capital Cost TOTAL</b>	<b>\$80,832,641</b>

### 4.3.3 Operations & Maintenance Cost

The operations and maintenance cost estimates were developed on the basis that a service contractor would maintain the various components of the system. Operation of the system during wet weather and dry weather events will be managed by the City. Operations of the diversion structure will incorporate coordination and notifications to the Los Angeles County Flood Control District to ensure that there will be no effect to the flood control conveyance system operation. **Table 7** estimates annual costs for typical operations and maintenance activities, not including the cost of long-term monitoring.

**Table 7.** Annual Estimated Operations & Maintenance Costs

Description	Frequency	No. of Times per Year	Unit Price	Total
<b>Diversion</b>				
Rubber Dam System – Inspection and Cleaning (Quantity = 2)	Monthly	12	\$750	\$18,000
Pretreatment Device – Vacuum	Monthly	12	\$250	\$3,000
Inspect Sediment Basin for Sediment Accumulation and Trash/Debris	Semi-annually	2	\$250	\$500
Remove Accumulated Trash and Debris in the Sediment Basin	Semi-annually	2	\$500	\$1,000
Remove Accumulated Sediment in the Forebay and Regrade	Every 5 Years	n/a	\$15,000	\$3,000

<b>Pump Station</b>				
Dry Season Inspection and Cleaning (Vacuum)	Every Other Month	6	\$500	\$3,000
Wet Season Inspection and Cleaning (Vacuum)	Every Other Month	6	\$500	\$3,000
Electrical Usage	Monthly	12	\$460	\$5,520
Valve Maintenance	As-needed	1	\$1,000	\$1,000
Control Panel Maintenance	As-needed	1	\$1,000	\$1,000
Pump Replacement	Every 20 years	n/a	\$25,500	\$1,275
<b>Storage</b>				
Trim Vegetation at the Beginning of Wet Season	Annually	1	\$5,000	\$5,000
Inspect Health of Wetlands Vegetation	Monthly	12	\$750	\$9,000
			<b>TOTAL</b>	<b>\$54,295</b>

## EXHIBIT B.2.1 SITE PLAN



CITIES OF ARCADIA, MONROVIA, AND SIERRA MADRE, LOS ANGELES COUNTY FLOOD CONTROL DISTRICT, AND THE COUNTY OF LOS ANGELES  
**RIO HONDO ECOSYSTEM RESTORATION PROJECT AND ARCADIA WASH WATER CONSERVATION DIVERSION**



PHASE 1

PHASE 2

Arcadia Wash Diversion = 37 cfs  
 Exist. IE=338.5  
 With Pretreatment Unit (DSBB)

L ≈ 10,000 ft

Rip-rap Energy  
 Dissipater &  
 Sediment Forebay  
 (3.3 ac-ft)



MH Connection  
 to Sawpit Wash

Property  
 Acquisition  
 Required

Parcel  
 Lines

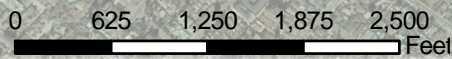
Spillway

Channel Diversion = 185 cfs  
 Sawpit Wash IE=332.0

Peck Road  
 Flood Control and  
 Water Conservation Basins

Peck Road  
 Water  
 Conservation  
 Park

Treatment Wetlands  
 Storage Capacity = 33.1 ac-ft  
 Length=2,400'; Depth=4'

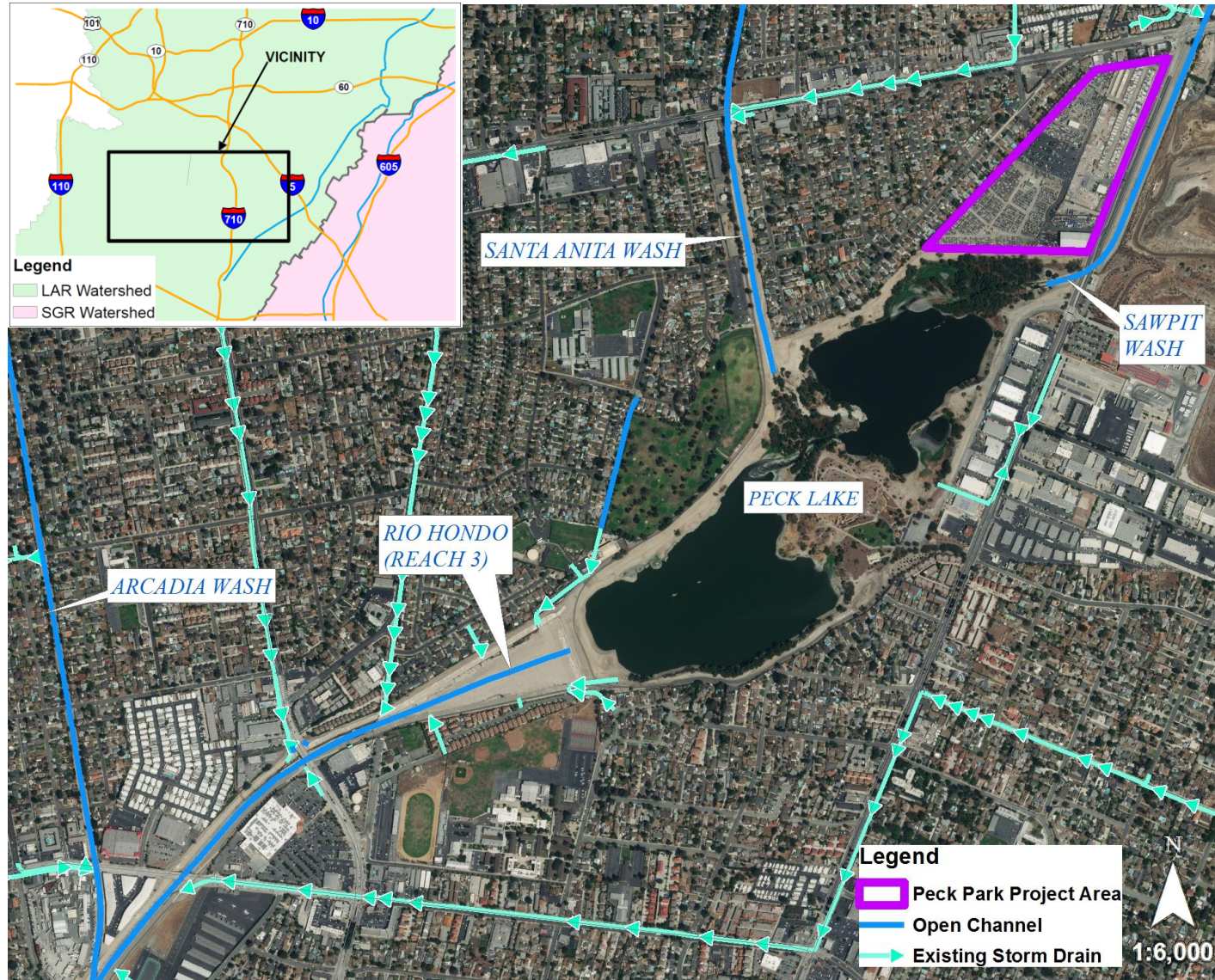


**PLAN VIEW**  
 (See Fact Sheet for Additional Details)

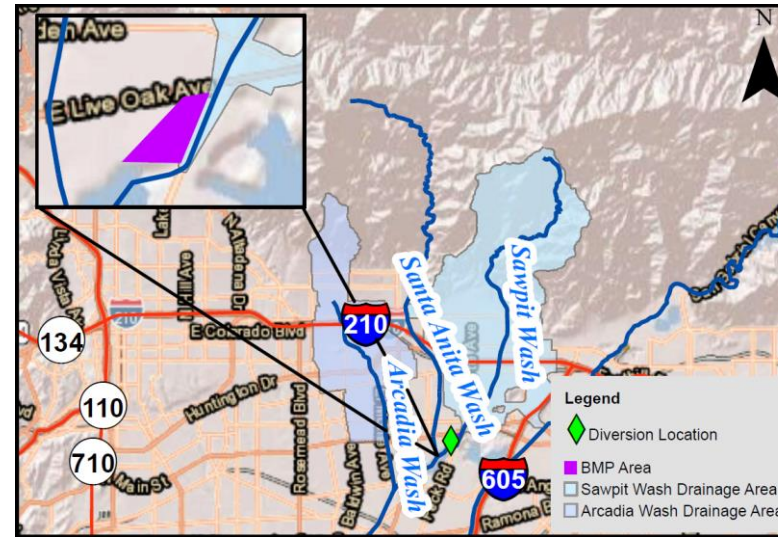


**EXHIBIT B.2.2 FACT SHEET**

## EXISTING SITE CONDITIONS



## DRAINAGE AREA



## DRAINAGE CHARACTERISTICS

DRAINAGE AREA OF EACH WASH (acres)	5,085 (Arcadia) 10,692 (Sawpit)
HYDROLOGIC SOIL GROUP	D
APPROX. DEPTH TO GROUNDWATER (ft)	42.1
SOIL DESCRIPTION	Well-drained/ somewhat excessively drained
MODELED AVERAGE ANNUAL RUNOFF VOLUME (ac-ft)	4,035.86 (Sawpit) 4,409.51 (Arcadia)

## BMP CHARACTERISTICS

LOCATION: CITIES OF ARCADIA AND MONROVIA

LAT: 34° 6'20.75"N  
LONG: 118° 0'33.85"W

**Proposed BMP Description:** The proposed project would restore a degraded Sawpit and Arcadia Wash by constructing approximately a 6.7-acre wetlands habitat area to treat stormwater flows prior to discharge into the Peck Road Water Conservation Basins and the downstream Rio Hondo Channel. The project would consist of two channel diversion structures and pipeline to convey stormwater flows from the Sawpit Wash and Arcadia Wash to the wetlands habitat area. Phase 1 would construct the Arcadia Wash Diversion to Sawpit Wash, and Phase 2 would construct the Sawpit Wash Diversion and the wetlands. The Arcadia Wash diversion would need a pretreatment unit and pump to convey flows to Sawpit Wash. The wetlands will create an area for native riparian habitat while providing a natural treatment system for the recharge basins downstream.

### Project Benefits:

- Aquatic Ecosystem Restoration with a natural treatment wetlands
- Increase habitat value with native/riparian vegetation for migratory birds and other sensitive species located within the area
- Water Quality Improvement in the Rio Hondo Channel, which discharges to the LA River

Vacant Lot - Potential Location for Pump and Pretreatment Unit (Source: Google Earth)



Arcadia Wash Confluence with Rio Hondo



Sawpit Wash (Corps Built Channel)



CITIES OF ARCADIA, MONROVIA, AND SIERRA MADRE, THE LOS ANGELES COUNTY FLOOD CONTROL DISTRICT, THE COUNTY OF LOS ANGELES, AND RIO HONDO ECOSYSTEM RESTORATION PROJECT AND ARCADIA WASH WATER CONSERVATION DIVERSION



**PROPOSED CONCEPTUAL SITE LAYOUT**



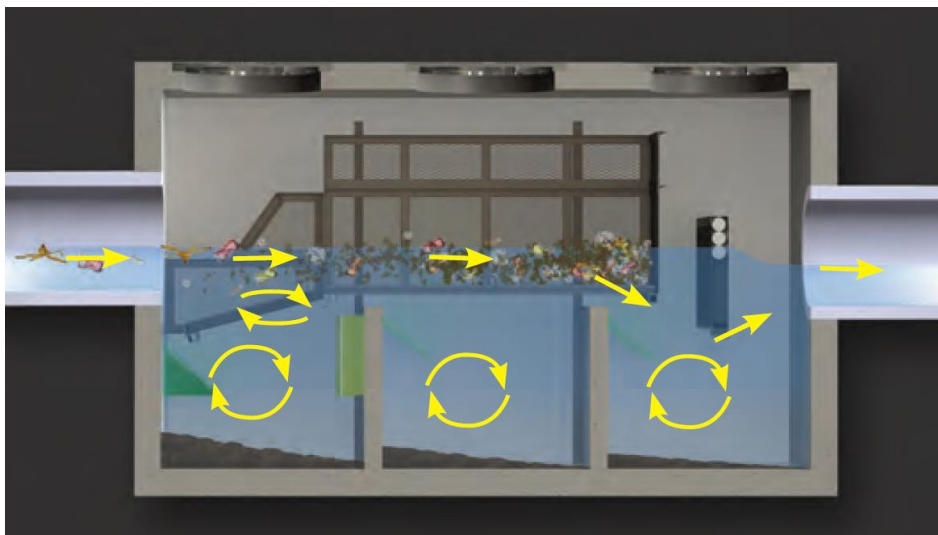
PLAN VIEW

**PLANNING-LEVEL COST ESTIMATE**

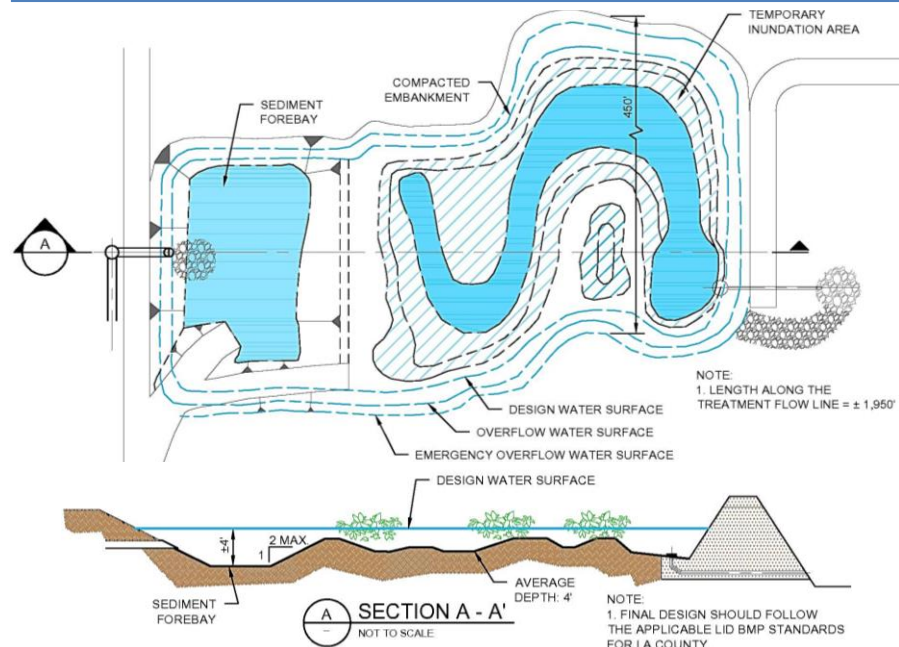
DESCRIPTION	TOTAL COST
<b>Phase 1 – Arcadia Wash Water Conservation Diversion</b>	
Arcadia Wash Diversion, Pretreatment, and Conveyance	\$5,997,500
Estimated Land Acquisition	\$1,390,000
<b>Phase 1 Subtotal</b>	<b>\$7,387,500</b>
Mobilization/Demobilization (5% of Subtotal)	\$147,750
Estimating Contingency (25% of Subtotal)	\$1,846,875
<b>Phase 1 Total Cost</b>	<b>\$9,382,125</b>
<b>Phase 2 – Rio Hondo Ecosystem Restoration Project</b>	
Sawpit Wash Diversion, Pretreatment, and Conveyance	\$16,789,000
Storage and Treatment	\$17,536,400
Estimated Land Acquisition	\$3,030,000
<b>Phase 2 Subtotal</b>	<b>\$37,355,400</b>
Mobilization/Demobilization (5% of Subtotal)	\$1,867,770
Estimating Contingency (25% of Subtotal)	\$9,338,850
<b>Phase 2 Total Cost</b>	<b>\$48,562,020</b>
<b>TOTAL COST</b>	<b>\$57,944,145</b>

**Note:** The land acquisition costs were estimated from the LA Property Assessment Information 2017 Roll Values.

**TYPICAL DEBRIS SEPARATING BAFFLE BOX (Source: BioClean Environmental, Inc.)**



**TYPICAL PLAN VIEW AND CROSS SECTION**



**PROJECT CHARACTERISTICS**

Zinc Reduction Achieved (Note: this project is nested; % Zn reduction contingent upon upstream project)	845 lb/yr (22.4%)
Design Diversion Rate from Sawpit Wash	185 cfs
Approx. Sawpit Wash Elevation at Diversion	332.0
Design Diversion Rate from Arcadia Wash	37 cfs
Approx. Arcadia Wash Invert Elevation at Diversion	338.5
Estimated Storage Capacity for Wetlands	33 ac-ft
Estimate Annual Groundwater Recharge	1,006 ac-ft/yr
Aquatic Ecosystem Restoration Area	6.7 acres

CITIES OF ARCADIA, MONROVIA, AND SIERRA MADRE, AND THE COUNTY OF LOS ANGELES  
**RIO HONDO ECOSYSTEM RESTORATION PROJECT AND ARCADIA WASH WATER CONSERVATION DIVERSION**



## **EXHIBIT B.2.3 DESKTOP GEOTECHNICAL STUDY**



Project No. TET 18-146E  
February 14, 2018

Mr. Brad Wardynski  
Tetra Tech  
3475 E. Foothill Blvd  
Pasadena, CA 91107

Subject: **DESKTOP EVALUATION REPORT  
PRELIMINARY INFILTRATION FEASIBILITY STUDY  
RIO HONDO AND SAN GABRIEL RIVER EWMP GROUP  
SW of Intersection between Peck Road and Live Oak Avenue  
Arcadia, California**

Dear Mr. Wardynski:

Presented herein is Tetra Tech's desktop evaluation report for the groundwater recharge program considered by the Rio Hondo and San Gabriel Enhanced Water Management Plan Group (EWMPG) to capture stormwater from the Sawpit Wash and subsequent treatment and infiltration at the project site located southwest of the intersection of Peck Road and Live Oak Avenue, in the City of Arcadia, California. This letter report summarizes the results of our research of the soils and groundwater conditions from readily available published literature and aerial photographs, and provides an opinion regarding the preliminary suitability of the onsite soils for infiltration. This letter report also provides recommendations for future investigation and infiltration testing at the site.

We appreciate the opportunity to provide our professional services on this project. If you have any questions regarding this report or if we can be of further service, please do not hesitate to contact the undersigned.

Respectfully submitted,  
**Tetra Tech**

*Fernando A. Cuenca*

Fernando Cuenca, Ph.D., P.E.  
Senior Project Engineer



*Peter Skopek*  
Peter Skopek, Ph.D., G.E.  
Principal Engineer



Distribution: Addressee (pdf by email [Brad.Wardynski@tetrattech.com](mailto:Brad.Wardynski@tetrattech.com))  
Emily Brown (pdf by email [Emily.brown@tetrattech.com](mailto:Emily.brown@tetrattech.com))

Filename: 2018-02-14 Rio Hondo SGR Desktop LET.docx

## 1. INTRODUCTION

This letter report presents the results of Tetra Tech’s desktop evaluation of the soils and groundwater conditions for the groundwater recharge program considered by the Rio Hondo and San Gabriel Enhanced Water Management Plan Group (EWMPG) to capture stormwater from the Sawpit Wash and subsequent treatment and infiltration at the project site located southwest of the intersection of Peck Road and Live Oak Avenue, in the City of Arcadia, California (see Figure 1). The project site is also located nearby quarries in the City of Irwindale, including the Hanson America Pit located approximately 0.2 miles to the east, URP Pit No.2 located approximately 0.5 miles to the northeast of the site, and URP Pit No.3 located approximately 1.3 miles to the northeast of the site.

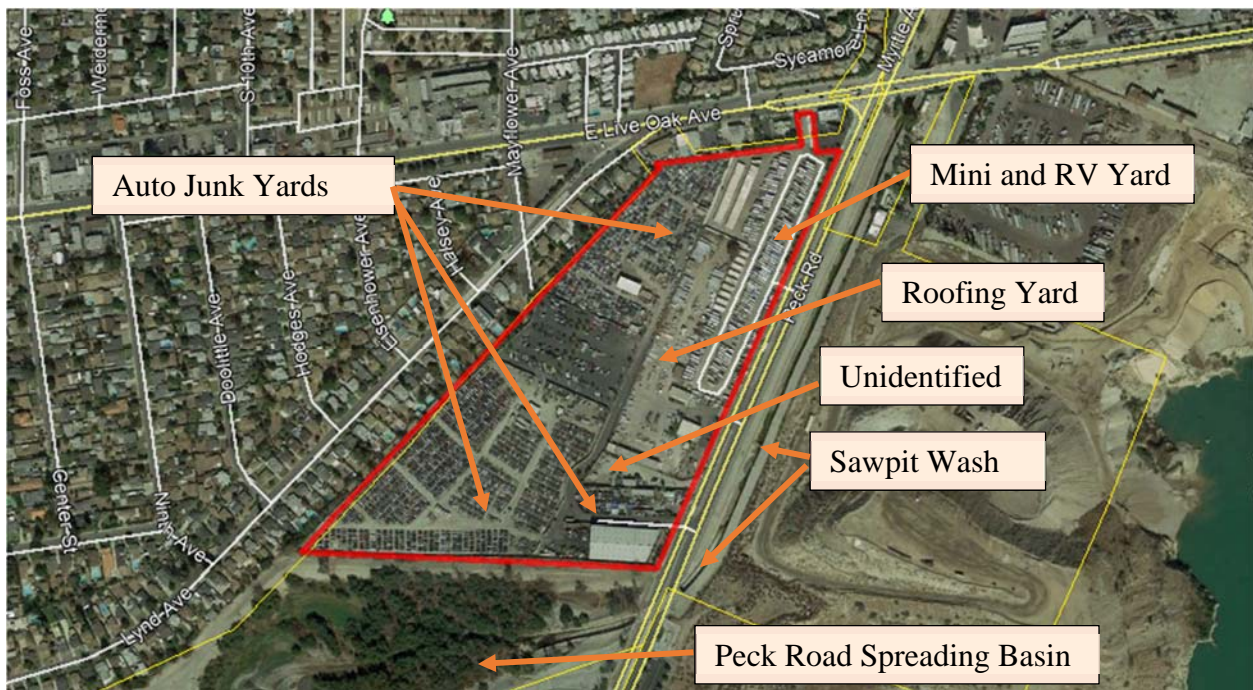


Figure 1. Approximate Site Location, City of Arcadia

## 2. SITE DESCRIPTION

The site is located immediately to the south of several restaurants located on the south side of Live Oak Avenue. The site is located immediately to the west of Peck Road and west of Sawpit Wash a concrete lined rectangular channel running north-south parallel to Peck Road. The Sawpit Wash turns west and goes under Peck Road at the southern end of the site flowing immediately into a

flood control basin known as Peck Road Spreading Basin located between Arcadia City Golf Course on the west and Peck Road Conservation Park to the east (see Figure 1).



**Figure 2. Project Site Features**

The site slopes gently towards the southwest with a maximum surface elevation of 354 feet at the northern boundary and a low elevation ranging from 334 to 342 feet along the southern boundary. Peck Road Spreading Basin located immediately to the south of the site has a bottom elevation of 280 feet in its northern part. Thus, the south slope leading from the site towards the Peck Road Spreading Basin is between about 54 and 62 feet high. There is no vegetation at the site, and the land is covered mostly by asphalt paved surfaces used for parking lots and storage yards with a several buildings in between.

The site has an area of about 32 acres and it is currently occupied by commercial facilities (see Figure 2) including:

- Roofing materials company (~4.4 acres);
- Storage facilities including mini and RV storage (~5.3 acres);
- An unidentified yard (~0.6 acres);
- The vast majority of the area is occupied by auto junk yards (~21.7 acres).

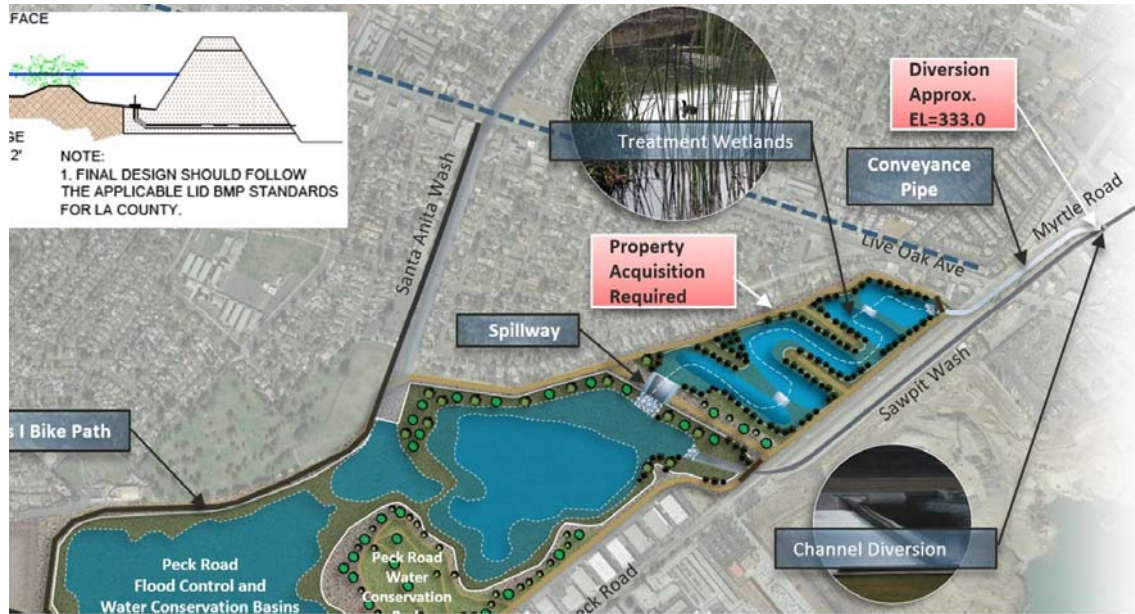
### 3. PROJECT DESCRIPTION

The project concept includes the following components (see Figure 3):

- Diversion and capture of stormwater from Sawpit Wash Channel at a location about 0.2 miles northeast of the site;



- Conveyance of captured stormwater to the site through an underground pipeline running under Myrtle Road and then under Peck Road and entering the site through the northeastern corner;
- Treatment and shallow infiltration at the site through a series of wetlands/shallow spreading basins built throughout the whole site;
- Construction of a spillway on the southern end of the site where any overflow would be discharged into Peck Road Spreading Basin.



**Figure 3. Proposed Project Components**

#### **4. SCOPE OF WORK**

Tetra Tech’s scope of services for this project consisted of the following tasks:

- Review of readily available background data, including in-house geotechnical data from our soil explorations in the vicinity of the proposed facilities to preliminarily assess the suitability of the onsite soils for infiltration purposes.
- Evaluation of groundwater conditions and provision of recommendations for future work and testing.
- Preparation of this letter report documenting the data acquired and our recommendations.

#### **5. AERIAL PHOTOGRAPH REVIEW**

Historical aerial photographs from the period between 1943 and 2011 were reviewed (see References). A summary of significant events at the site follows below:

- Early 1940s: Mining operations for aggregates took place throughout the whole site area during the 1940s. Images from 1943 indicate the presence of a deep excavation

at the site with a mining pit wall around the present site. The mining pit wall follows closely, although not exactly, along the current western and northern boundaries of the site, indicating that the properties immediately to the north of the site and to the west, where the current residences are located, are likely to be founded on native alluvium. The mining pit wall also follows closely Peck Road indicating that Peck Road was also built on native alluvium.

- 1947-1948: The southern two thirds of the site were excavated to a greater depth than the northern third. Aerial photographs from March 1947 indicate the presence of water at the bottom of the mining pit in the southern two thirds of the pit which indicates that in this area the pit was excavated to a depth of at least 35 feet, based on groundwater elevation of 309 feet from a nearby well on that date and a current ground elevation at about 345 feet. However, the full depth of the pit excavation is unknown. The current Peck Road Spreading Basin bottom in the northern end of the basin is at elevation of about 280 feet. This area was a part of the southern portion of the project site, which would indicate that the pit was excavated to a depth of 65 feet in this area. The northern third of the pit was not excavated as deep (less than 35 feet) since there is no water observed in this part of the pit on the reviewed photographs, but the full depth of excavation in this area is unknown.
- 1950-1960: In the 1950s reclamation of the pit seems to have taken place, with the southern two thirds of the site being brought to almost final reclamation grade by 1960. The northern third of the mining pit seems to have reached final grade at about the same time or before although it is not clear from the time gaps in the reviewed photographs. By 1960 the southern boundary of the present site and the general grading in this area had been defined by the fill slope along the southern boundary sloping down into the northern end of the Peck Road Spreading Basin where Sawpit Wash Channel flows into the basin.
- 1962-1965: Aerial photographs from 1962 indicate the presence of a new development including access roads and new houses built over the reclaimed fill materials at the northwest quadrangle of the site where currently some of the auto junk yards are located. Photographs from 1965 indicate that the houses were still there.
- 1970: Photographs from 1970 do not show the houses. The cause of removal of the houses is unknown and is not clear why the houses were present at the site for only a short period of time. A possible hypothetical explanation could be excessive settlement of the fill materials leading to structural damage of the dwellings.
- 1972: By 1972 different areas of the site were being used as auto junk yards, and the site general configuration has remained since then basically the same as that of today.

- 2017: The majority of the site is still occupied by auto junk yards and commercial use as indicated in the Section Site Description.

## 6. SUBSURFACE CONDITIONS

### 6.1. Regional Geology

The site is located near the north-central portion of the San Gabriel Valley, an east-trending structural depression located at the northeast extent of the Los Angeles basin. The San Gabriel Valley is bounded to the north by the San Gabriel Mountains which have been uplifted along the reverse faults that comprise the Sierra Madre Fault System. The northern portion of the San Gabriel Valley, in the vicinity of the site, has been infilled with sediments eroded from the San Gabriel Mountains and deposited on alluvial fans associated with the San Gabriel River, located about 2.7 miles northeast of the Pit, and the Sawpit Canyon drainage located about 3.9 miles to the northeast of the site. Based on mapping by the CDMG (1998), the alluvial fan deposits are late-Pleistocene to early-Holocene age and are composed primarily of sand and gravel that are moderately-well consolidated as indicated by the conditions exposed in nearby quarry walls (URP Pit No.2 located about 0.6 miles to the northeast of the site). In general, the presence of fine-grained horizons (i.e., silt and clay) is typically rare.

Geologic structure within the alluvial outwash fan complex is generally flat with a very gentle gradient to the south. No evidence of significant local folding or fault deformation has been observed in nearby quarry wall exposures (URP Pit No.2) or interpreted from the available aerial photographs or literature.

### 6.2. Site Geology

Originally the site was mantled by Quaternary alluvial deposits (Qg) of Holocene age consisting of gravel and sand of major streams and alluvial fan detritus from San Gabriel Mountains (Dibblee and Ehrenspeck, 1999). After mining, the excavated native alluvial materials were replaced with imported fill as well as some mining wash deposits to depths of at least 35 feet in the southern two thirds of the site and shallower but to unknown depths in the northern third of the site. Photographs from 1947 indicate that wash materials from mining activities had been placed in the northern area of the southern two thirds of the pit and they were fanning towards the south. Based on our experience with other mining pits in the area, these materials are usually dumped and placed in an uncontrolled manner and tend to be silts to sands in nature.

The fill materials used to reclaim the mining pit are in general unknown as well as the quality of the fill i.e., engineered fill vs. uncontrolled fill. However, it is conceivable based on our experience with other reclaimed fills in the area that the fill materials are likely to consist of soil fill and concrete rubble fill in addition to the mining wash materials. Some of the reclaimed mining pits in the Irwindale area also include tires and even localized areas of municipal solid waste but this was not observed in our limited aerial photograph review and was not part of our assessment.

The reclaimed fill materials are underlain by Quaternary-aged coarse-grained native alluvium deposited mainly by the San Gabriel River. The alluvium is divided into two units, younger (Qg,

Holocene age) and older alluvium (Qof, Holocene to Pleistocene age). It is likely that the majority of the younger alluvium was excavated during mining operations and thus, the older alluvium underlies most of the existing reclaimed fill materials.

Based upon alluvial exposures at the depth of mining in nearby quarries, Hanson America Pit, URP Pit No.2 and URP Pit No.3, the depth to bedrock is likely several hundred feet and the bedrock contact at the site is likely close to sea level.

### 6.3. Infiltration Capacity of Fill Materials

Although the nature of the fill materials is unknown as well as their degree of compaction, some preliminary information regarding the infiltration capacity of the surficial soils is provided by the USDA Natural Resources Conservation Service website (<https://websoilsurvey.sc.egov.usda.gov/App/WebSoilSurvey.aspx>) which maps the surficial soils at the site as consisting of discontinuous human-transported material overlying alluvium. The surficial soils are described as fine sandy loam with an estimated moderately high to high saturated hydraulic conductivity ranging between of 0.57 to 1.98 inches/hour. Assuming a hydraulic gradient of 1 and applying recommended reductions factors from the County of LA guidelines GS200.2 (2017) an equivalent design infiltration rate can be obtained. For this purpose the following reduction factors were assumed:

- a reduction factor  $RF_f$  of 2 to account for the direction of flow during the test and the reliability of the testing method (typical range between 2 and 3);
- a reduction factor  $RF_v$  of 2 (typical range between 1 and 3) to account for effects related to site subsurface variability; and
- a reduction factor  $RF_s$  of 2 (typical range between 1 and 3) to account for long-term siltation, and plugging of the facility.

Thus, the range of hydraulic conductivities provided above can be converted into equivalent design infiltration rates ranging between 0.07 and 0.25 inches/hour which are lower than the minimum design infiltration rate established by GS200.2 (2017).

Tetra Tech (2016) has performed infiltration testing per ASTM D3385 at the Manning Pit in the City of Irwindale on imported engineered fill fine-grained materials using a Double Ring Infiltrometer (DRI). The fill materials were recently placed in the pit during reclamation activities. The 2 DRI tests were conducted on engineered fill placed at 93 percent relative compaction as determined by ASTM D1557. The fill materials at the test locations were classified as sandy lean clay to lean clay with measured infiltration rates of about 0.05 inches/hour. This infiltration rate would correspond after applying the corresponding reduction factors to a design infiltration rate of about 0.007 inches/hour, much lower than the minimum design infiltration rate established by GS200.2 (2017). These infiltration rates may not be applicable to the majority of the project site, as it is surmised from the available information that it is very likely that the reclamation fill was mostly non-engineered fill.

Tetra Tech (2016) also performed infiltration testing on native alluvial materials using a DRI per ASTM D3385 at the Manning Pit located in the City of Irwindale about 4 miles to the east of the

site. The dense to very dense alluvial materials corresponded to the older alluvium, were somewhat cemented and consisted predominantly of gravel with sand and sand with gravel. The 2 measured DRI infiltration rates were between 6.9 and 7.5 inches/hour. These infiltration rates would correspond after applying the corresponding reduction factors to a design infiltration rate of about 0.9 inches/hour, higher than the minimum design infiltration rate established by GS200.2 (2017).

The nature and consistency of the fill materials at the site however is not known, and it is likely that a good portion of these materials consists of non-engineered fills placed with little or no compactive effort and made of materials with varying gradations ranging from fine-grained materials from mining wash operations to coarser-grained import materials including silty sands with cobbles and large concrete rubble particles. Thus, a high degree of non-homogeneity in the material composition is expected at the site. This non-homogeneity could also affect significantly the infiltration capacity at the site, with infiltration rates below and above the minimum acceptable infiltration rate.

In summary, because of the nature of the fill materials at the site and the likely variations in the degree of compaction, infiltration rates could vary widely at the site. For an effective design it is recommended that several infiltration tests be conducted at different locations throughout the whole site within the upper 10 to 15 feet to obtain a statistical measure of the infiltration rate that can be considered representative of the whole site and can be used as the overall design infiltration rate. If the design infiltration rate is found to be acceptable i.e., larger than the minimum percolation rate per GS 200.2 (2007), then this rate would need to be further confirmed at a later stage by large scale field percolation testing.

#### **6.4. Groundwater**

As reported by the CDMG (1999) for the El Monte Quadrangle, the interpolated historic high groundwater at the site is at a depth of 35 to 40 feet, i.e., at about elevation 305 to 310 feet. The interpolated historic high groundwater elevation contours for the site developed from circa 1945 (Irwindale Slope Stability Committee, 2003) indicate a high groundwater elevation of 320 feet, equivalent to a groundwater depth of about 14 to 25 feet below current grade elevation at the site (ranging from 334 to 345 feet). However, it is recognized that the CDMG groundwater contours are based on early last century water well logs (Mendenhall, 1905, Conkling, 1927) and also include water measurements from wells from the Central Basin Investigation (State Water Resources Board, 1952), Department of Water Resources (circa 1940's) which reflect conditions prior to massive infrastructure and urban development that has taken place in the last 50 years which modified the drainage and infiltration patterns and therefore they may not correspond or apply to current conditions and circumstances. For that reason the City of Irwindale (2003) has adopted groundwater levels for design purposes that correspond closer to the anticipated conditions in the general area within the design life of the quarries in the area. The anticipated design groundwater level for the project site is between 275 and 280 feet, i.e., groundwater depth between 54 and 70 feet.

Since early 2010, the City of Irwindale has maintained weekly to monthly lake water level records for URP Pit Nos.2 and 3. A compilation of data in graphic format is presented in Figure 4. Since

early 2010, lake levels in Pit No.2 have varied from a low elevation of around 172 feet (July of 2016) to a high elevation of around 239 feet (November of 2011). In general, recorded lake levels have been slightly higher at Pit No.3 as compared to Pit No.2, on the order of a few feet.

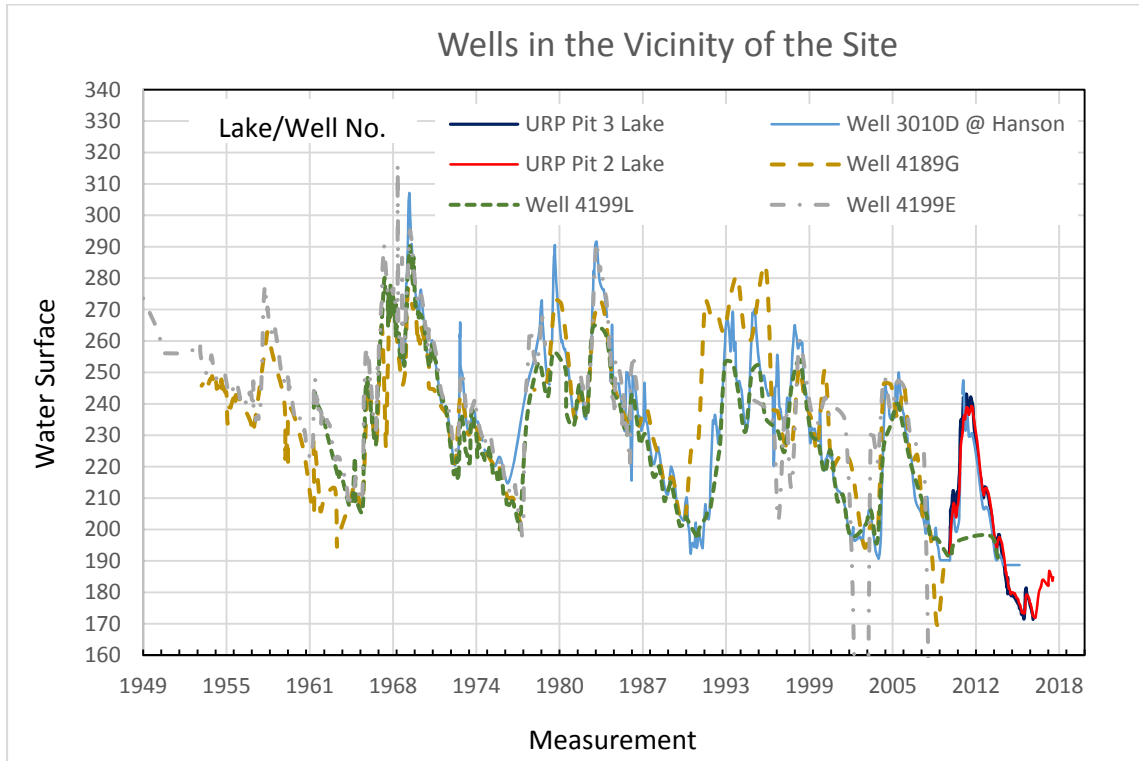
Well data from the Los Angeles County Department of Public Works (LACDPW) database (<http://dpw.lacounty.gov/general/wells/>) for nearby wells (less than 0.5 miles from the site) indicate groundwater elevations as summarized in Table 1. The historical data for these wells is also included in Figure 3. Historical groundwater data taken from 1968 to 2015 from a well located at Hanson Pit about 0.5 miles to the east of the site is also included in Figure 4. The historical groundwater data for all 3 nearby quarries (Pit 2, Pit 3 and Hanson) since 2010 is in good agreement. The data from all the wells is also in good agreement and the trends are the same throughout the whole monitoring period. The variations in water elevations among wells are at the most about 20 feet and they are likely attributed to variations in groundwater gradients throughout the general area.

**Table 1**  
**Groundwater Wells in the Immediate Vicinity of the Site**

Well Identification	Monitoring Period	Approximate location relative to the site	Maximum Water Surface Elevation
LACDPW Well ID 4199E State # 1S11W11F04	September 1948 to October 2010	Immediately to the south of the site on Peck Road Spreading Basin	316 feet on July 1968
LACDPW Well ID 4199L State # 1S11W11C05	March 1962 to November 2013	0.05 miles to the west	290 feet on June 1969
LACDPW Well ID 4189G State # 1S11W10H01	September 1953 to October 2009	0.25 miles to the southwest	284 feet on April 1996
LACDPW Well ID 3010D @ Hanson Pit State # 1S11W12G01	August 1968 to October 2017	0.5 miles to the east	350 feet on October 1985* 307 feet on May 1969
*This high groundwater elevation is an isolated point that does not fit the general pattern for this well or the other wells in the vicinity			

Based on the explorations at the site and the well data, it is our conclusion that the maximum groundwater at the site has been at about elevation 290 feet within the last 45 years, i.e., equivalent to a groundwater depth of about 44 to 55 feet below the current grade. Based on this well data and the groundwater design elevations from the City of Irwindale, the requirement by the LACDPW guidelines to maintain at least a 10 foot clearance between the invert of the infiltration facility and the groundwater level is met at this site, as shallow infiltration is being considered in the current project concept.

Fluctuations of the groundwater level, localized zones of perched water, and increased soil moisture content should be anticipated during and following the rainy season. Irrigation of landscaped areas adjacent to the site can also cause a fluctuation of local groundwater levels. Recharging and water management at the Santa Fe Dam has also been known to influence local groundwater levels.



**Figure 4. Groundwater Elevation from Pit Lake and Monitoring Well Data**

## 7. SEISMICITY

The closest active fault to the site is the Duarte Fault, part of the Sierra Madre Fault Zone, D section, located about 3 miles (4.8 km) to the north northeast of the site. These and other faults considered capable of generating shaking of seismic significance are summarized in Table 2.

**Table 2**  
**Regional Fault Sources**

<b>Fault/Fault Zone</b>	<b>Fault Type</b>	<b>Approximate Closest Distance to Site (km) <sup>(1)</sup></b>
Duarte Fault - Sierra Madre Fault Zone (D-Section)	Reverse	4.8
Sierra Madre Fault - Sierra Madre Fault Zone (D-Section)	Reverse	5.8
Raymond	Left Lateral Strike Slip	4.9
Sierra Madre Fault - Sierra Madre Fault Zone (C-Section)	Reverse	6.1
East Montebello Fault	Right Lateral Strike Slip	9.0
Upper Elysian Park Blind Thrust	Reverse	11.0
Indian Hill Fault	Right Lateral Strike Slip	11.0
San Jose Fault (Southern California)	Left Lateral Strike Slip	13.9
Elsinore Fault Zone (Whittier Section)	Right Lateral Strike Slip	14.1
Puente Hills Blind Thrust	Reverse	21.5
San Andreas Fault	Right Lateral Strike Slip	43

A large amount of seismic activity and associated events with their epicenters have been recorded surrounding the project site. Notable historic earthquakes in southern California of significance to the project are included in Table 3.



**Table 3**  
**Historic Earthquakes in Southern California**

Earthquake Name	Year	Fault and Fault Type	Earthquake Magnitude*	Epicenter	
				Latitude	Longitude
Chino Hills	2008	Whittier fault (left-lateral thrust)	5.5 M <sub>w</sub>	33.95°N	117.76°W
Northridge	1994	Northridge Thrust (blind thrust)	6.7 M <sub>w</sub>	34.21°N	118.54°W
Sierra Madre	1991	Clamshell-Sawpit Canyon fault (reverse)	5.8 M <sub>L</sub>	34.20°N	118.14°W
Upland	1990	San Jose fault (left-lateral strike-slip)	5.4 M <sub>L</sub>	34.13°N	117.70°W
Pasadena	1988	Raymond fault (left-lateral strike-slip)	5.0 M <sub>w</sub>	34.14°N	118.13°W
Whittier Narrows	1987	Puente Hills Fault (blind thrust)	5.9 M <sub>L</sub>	34.06°N	118.08°W
San Fernando	1971	San Fernando fault (thrust)	6.5-6.7 M <sub>w</sub>	34.42°N	118.37°W
Lytle Creek	1970	Lytle Creek fault (right-reverse)	5.2 M <sub>L</sub>	34.27°N	117.54°W
Torrance-Gardena	1941	Palos Verdes fault (right-reverse)	4.8 M <sub>L</sub>	33.82°N	118.22°W
Long Beach	1933	Newport-Inglewood fault (right-lateral strike-slip)	6.4 M <sub>w</sub>	33.63°N	118.00°W
San Jacinto	1923	San Jacinto fault (right-lateral strike-slip)	6.3 M <sub>L</sub>	34.00°N	117.24°W
San Jacinto	1918	San Jacinto fault (right-lateral strike-slip)	6.7 M <sub>w</sub>	33.65°N	117.43°W
Elsinore	1910	Elsinore fault (right-lateral strike-slip)	6 M <sub>L</sub>	33.75°N	117.45°W
Fort Tejon	1857	San Andreas fault (right-lateral strike-slip)	7.9 M <sub>w</sub>	35.43°N	120.19°W
*M <sub>w</sub> refers to Moment Magnitude scale M <sub>L</sub> refers to Local Magnitude scale					

Potential seismic sources of significance to the project include active faults previously listed and faults that are not known to break the ground surface but are considered active. This latter group of faults includes buried or “blind” thrust faults. Current tectonic models for the Los Angeles Basin include the presence of buried thrust faults, several of which are considered partly responsible for the north-to-south compression of the basin. Although these faults are not currently zoned by the State of California for surface rupture hazards (Earthquake Fault Zones), many are considered capable of generating seismic shaking of significance to structures.

Of these buried active faults the closest to the site is the Puente Hills Trust Fault (PHTF). The PHTF is currently defined as 3 separate but juxtaposed, generally east-west trending and north-dipping, fault surfaces underlying Downtown Los Angeles to Brea. From west to east these include the Los Angeles, Santa Fe Springs, and Coyote Hills segments. Based upon recent studies

by several researchers, including Shaw et al., (2002), Olsen and Cooke (2005), and Leon et al. (2007), the three fault surfaces are interpreted to extend from depths in excess of 9 miles on the north side of the Los Angeles Basin to less than 1.2 miles at the southerly limits of the fault surfaces in the central portion of the basin. Fault surface geometries are interpreted from historical petroleum exploration data, limited geotechnical subsurface exploration data, and limited seismicity (i.e.; the 1987 magnitude 5.9 Whittier Narrows earthquake).

Leon et al. (2007) estimates that upwards of 60 percent of the total Los Angeles Basin compression may be attributed to strain along the PHTF. Although ground rupture has not been officially attributed to the fault, the presence of youthful hills (e.g., Coyote Hills) and shallow folding at depth in the upper portion of the interpreted thrust ramp suggests recent activity. The PHTF is considered capable of generating earthquake magnitudes up to about  $M_w$  7.0.

### **7.1. Surface Fault Rupture**

Official Maps of Earthquake Fault Zones were reviewed to evaluate the location of the project site relative to active fault zones. Earthquake Fault Zones (known as Special Studies Zones prior to 1994) have been established in accordance with the Alquist-Priolo Special Studies Zones Act enacted in 1972 (California Geological Survey, 2008). The Act directs the State Geologist to delineate the regulatory zones that encompass surface traces of active faults that have a potential for future surface fault rupture. The purpose of the Alquist-Priolo Act is to regulate development near active faults in order to mitigate the hazard of surface fault rupture.

The site is not located within a designated Alquist-Priolo Earthquake Fault Zone for fault surface rupture hazard. Further review of the 2010 Fault Activity Map of California (Jennings and Bryant, 2010) indicates that no surface traces of any active or potentially active faults pass directly through or in the general vicinity of the site. The potential for surface rupture due to faulting occurring beneath the project site is considered to be minimal.

### **7.2. Seismic Hazard Zones**

Maps of seismic hazard zones are issued by the California Geological Survey (CGS, formerly California Department of Conservation, Division of Mines and Geology (CDMG)) in accordance with the Seismic Hazards Mapping Act enacted in April 1997. The intent of the Seismic Hazards Mapping Act is to provide for a statewide seismic hazard mapping and technical advisory program to assist cities and counties in developing compliance requirements to protect the public health and safety from the effects of strong ground shaking, liquefaction, landslides, or other ground failure and other seismic hazards caused by earthquakes.

Based on a review of the El Monte Quadrangle Official Map of Seismic Hazard Zones issued November 6, 2014, the proposed development is located within an area identified by the State of California as subject to the hazard of liquefaction.

It is anticipated that recharge at the site would likely increase the liquefaction potential within the fill materials although it should not impact significantly the performance of the proposed infiltration basins/wetlands. However, it is important that the design of the infiltration

basins/wetlands keeps a proper setback from the nearby homes and structures, as well as a proper setback from Peck Road to limit any increase in the liquefaction susceptibility of these areas.

### **7.3. Earthquake-Induced Landslides**

The site is not located in an Earthquake-induced Landslide Hazard Zone on the State of California El Monte Quadrangle Seismic Hazard Zones Map. Therefore the occurrence of an earthquake-induced landslide at the site is not considered to be a hazard to the site. However, it is likely that the reviewing agency for this project may require a new assessment of the static and seismic stability of the slopes on the southern end of the property under conditions that incorporate the new seepage conditions along that end. The design team will need to assess the proper hydraulic conditions for the design of the spillway and associated flood control structures along the southern end of the site.

### **7.4. Lateral Spreading**

As mentioned before the proposed development is located within an area identified by the State of California as subject to the hazard of liquefaction. The risk of lateral spreading would need to be evaluated on the exposed slope face along the southern edge of the property. It is also very likely that groundwater recharge through infiltration by the proposed project will increase the risk of lateral spreading if liquefaction is determined/identified to be a hazard at the site.

## **8. CONCLUSIONS AND RECOMMENDATIONS**

Based on our review of the available literature the site was used as an aggregate mining pit. The site was reclaimed. However, the fill materials used to reclaim the mining pit are in general unknown as well as the quality of the fill, i.e., engineered fill vs. uncontrolled fill. The fact that the houses that were built there in the 1960s remained there only for a few years may be an indication that the fill was performing poorly. It is also likely that the pit contains mining wash materials consisting of silts and fine-grained sands, which are materials that could limit infiltration. The site appears to be underlain by fill materials to a depth of 20 to 30 feet in the northern 1/3 of the site and to a depth of at least 35 feet and up to 65 feet in the southern 2/3 of the site.

Uncontrolled fills are likely to be looser and potentially have larger voids as compared to engineered fills, and thus are considered potentially more suitable for infiltration potential. However, the infiltration rates for the in situ materials remain unknown and it is anticipated that great variability in infiltration rates will occur spatially and at depth. Typically non-engineered fills possess variable infiltration rates. It is expected that this project would be designed on the basis of an overall characterization of the fill mass to establish a statistically significant infiltration rate. In practical terms this means performing multiple near-surface DRI tests and borehole percolation tests to assess the spatial variability of the fill infiltration rate and designing for a reasonable lower-bound. If after performing the recommended testing above, the site is considered feasible, large scale infiltration testing will likely be required to confirm the assumed performance in accordance with County of Los Angeles infiltration criteria and testing methods before the design can be finalized.

To ascertain the characteristics of the onsite subsurface materials, a subsurface investigation consisting of soil borings and Cone Penetration Tests (CPTs) is recommended. The proposed investigation would provide information regarding the properties of the fill materials and their variability throughout the site and with depth.

The borings/CPTs will also be needed to assess the stability of the southern slope descending into the adjacent Peck Road Spreading Basin under static and seismic conditions and to evaluate the liquefaction potential at the site under existing and operational conditions during recharge activities.

It is noted that the site is located in a zone mapped as subject to liquefaction hazard. However the effects of potential liquefaction on the performance of the spreading basins is not considered to be a design issue, except for the potential to influence the stability of the southern slope descending into the adjacent Peck Road Spreading Basin and the structures to be located there, i.e., spillway, earthen flood control structure. Given the presence of a free face slope along the southern boundary, the potential for lateral spreading will likely need to be evaluated.

The proposed flood control structures along the southern boundary including the proposed spillway and the earthen flood control dam will need to be designed considering the nature of the subsurface materials and the likelihood of liquefaction in that area. Ground improvement methods may be required on that end of the site in order to meet regulatory performance criteria that would include operational safety and diminishing risks related to the consequences of possible large deformations during seismic events.

It is also recommended that additional borings be drilled in the native alluvium present immediately outside of the project site to assess the liquefaction potential in those areas where the houses have been built adjacent to the western boundary and where the restaurants have been built adjacent to the northern boundary.

In summary, given the nature and history of the site, it is Tetra Tech's opinion that the project is possibly suitable and further investigation is warranted. The proposed infiltration basins for the site are likely to enhance the use of the land and improve the recharge of the groundwater within the basin. Tetra Tech recommends that the site be considered at this stage as potentially viable for infiltration pending further geotechnical investigations and infiltration testing, which will be required to assess the actual infiltration rates at the site which at the moment are unknown. Our review did not include any environmental assessment of the site and this will need to be addressed by others.

## 9. LIMITATIONS

The recommendations and opinions expressed in this report are based on Tetra Tech's limited initial review of the available information obtained through our research. It is expected that additional field explorations and infiltration testing will be needed to advance and support the design of the intended infiltration basins/wetlands. Furthermore, additional hydrogeological modeling will likely be required for the expected infiltration volumes for this project.

It should be noted that this study did not evaluate the presence of hazardous materials on any portion of the site. Conditions not observed and described in this report may be present on the site. Uncertainties relative to subsurface conditions can be reduced through additional subsurface exploration and small and large scale field infiltration testing. Additional subsurface evaluation, field infiltration testing, and laboratory testing can be performed upon request.

Site conditions, including groundwater level, can change with time as a result of natural processes or the activities of man at the subject site or at nearby sites. Changes to the applicable laws, regulations, codes, and standards of practice may occur as a result of government action or the broadening of knowledge. The findings of this document may, therefore, be invalidated over time, in part or in whole, by changes over which Tetra Tech has no control. Therefore, this report should be reviewed and recertified if it were to be used for a project design commencing more than 1 year after the date of issuance of this report.

This document is intended to be used only in its entirety. No portion of the document, by itself, is designed to completely represent any aspect of the project described herein. Tetra Tech should be contacted if the reader requires additional information or has questions regarding the content, interpretations presented, or completeness of this document. Reliance by others on the data presented herein or for purposes other than those stated in the text is authorized only if so permitted in writing by Tetra Tech. It should be understood that such an authorization may incur additional expenses and charges.

Tetra Tech has endeavored to perform its evaluation using the degree of care and skill ordinarily exercised under similar circumstances by reputable geotechnical professionals with experience in this area in similar soil conditions. No other warranty, either expressed or implied, is made as to the conclusions and recommendations contained in this report.

We appreciate the opportunity to assist you with this project. Should you have any questions, please feel free to contact our office.

## 10. SELECTED REFERENCES

- California Department of Conservation, Division of Mines and Geology, 2008, Guidelines for Evaluation and Mitigation of Seismic Hazards in California: Special Publication 117.
- California Department of Conservation, Division of Mines and Geology, 1998, Seismic Hazard Zone Report for the El Monte 7.5-Minute Quadrangle, Los Angeles County, California: Seismic Hazard Zone Report 024.
- California Department of Conservation, 1999, State of California Seismic Hazards Zones, Baldwin Park Quadrangle: Division of Mines and Geology, scale 1:24,000, Released March 25, 1999.
- California Department of Conservation, 2008, Seismic Hazard Zone Report for the Baldwin Park 7.5-Minute Quadrangle, Los Angeles County, California: Division of Mines and Geology Seismic Hazard Zone Report 022, 45 p., attachments.
- California Geological Survey (CGS), 2014, Earthquake Fault Zones and Seismic Hazard Zones for the El Monte Quadrangle 7.5-Minute Quadrangle, Revised Official Map, Los Angeles County.
- Cao, T., Bryant, W. A., Rowshandel B., Branum D., and Wills C. J., 2003, The Revised 2002 California Probabilistic Seismic Hazard Maps June 2003.
- County of Los Angeles, Department of Public Works (DPW), 2017, Administrative Manual, Guidelines for Design, Investigation, and Reporting Low Impact Development Stormwater Infiltration. GS200.2, Alhambra, California, dated June 30, 2017.
- County of Los Angeles, Department of Public Works (DPW), 2014, Low Impact Development Standards Manual, Alhambra, California, dated February, 2014.
- Department of Ecology State of Washington, 2014. 2012 Stormwater Management Manual for Western Washington as Amended in December 2014 (The 2014 SWMMWW). Publication Number 14-10-055.
- Dibblee, T.W., and Ehrenspeck, H.E., 1999, Geologic map of the El Monte and Baldwin Park quadrangles, Los Angeles County, California: Dibblee Geological Foundation, Dibblee Foundation Map DF-69, scale 1:24,000.
- Dibblee, T.W., and Minch, J.A., 2002, Geologic map of the Baldwin Park quadrangle, Los Angeles County, California: Dibblee Geological Foundation, Dibblee Foundation Map DF-89, scale 1:24,000.
- Harden, D.R., 2004, California Geology, Second Edition, Pearson Education Inc.

- Irwindale Slope Stability Committee, 2003, Guidelines for Stability Analyses of Open Pit Mines, Irwindale, California (dated December 24, 2003).
- Jennings, C.W. and Bryant, W.A., 2010, Fault Activity Map of California: California Geological Survey Geologic Data Map No. 6, scale: 1:750,000.
- Leon, L. A., Christofferson, S. A., Dolan, J. F., Shaw, J. H., and Pratt, T. L., 2007, Earthquake-by-earthquake fold growth above the Puente Hills, blind thrust fault, Los Angeles, California: Implications for fold kinematics and seismic hazard, *J. Geophys. Res.*, 112.
- Naval Facilities Engineering Command (NAVFAC), 1982. Soil Mechanics, Foundations and Earth Structures. Design Manuals 7.01 and 7.02.
- Norris, R. M., and R. W. Webb, 1990, *Geology of California*, John Wiley & Sons, N.Y.
- Olson, E.L. and Cooke, M.L., 2005, Application of Three Fault Growth Criteria to the Puente Hills Thrust System, Los Angeles, California, USA: *Journal of Structural Geology* 27(2005)1765-1777.
- Shaw, J., Plesch, A., Dolan, J. F., Pratt, T. L., Fiore, P., 2002, Puente Hills Blind-Thrust System, Los Angeles, California, *Bulletin of the Seismological Society of America (Seismological Society of America)* 92 (8): 2946–2960.
- United States Department of Agriculture (USDA) Natural Resources Conservation Service, 2007. *National Engineering Handbook - Part 630 Hydrology*. Chapter 7, Hydrologic Soil Groups.
- Terzaghi, K., Peck R., and Mesri G., (1996), *Soil Mechanics in Engineering Practice*, Third Edition, Published by Wiley-Interscience, February 7, 1996.
- Tetra Tech BAS GeoScience (2016), Construction Memorandum #26, Manning Pit Backfill and Reclamation, Infiltration Testing – Engineered Fill, Irwindale, California, dated November 2, 2016.

**Reviewed Aerial Photographs**

<b>Flight Date</b>	<b>Source</b>	<b>Flight</b>	<b>Frame</b>	<b>Scale</b>
1928	Fairchild Aerial Photography Col.	159	A-6, A-7	1"=1,000'
11-25-1943	Fairchild Aerial Photography Col.	C 8648	15, 16	1"=500'
3-15-1947	Fairchild Aerial Photography Col.	C 11290	1-25, 1-26	1"=500'
9-11-1948	Fairchild Aerial Photography Col.	C 12914	1-30, 1-31	1"=400'
11-10-1952	Continental Aerial Photo, Inc.	AXJ-5K	36, 37, 38	1"=1,666'
4-3-1960	Continental Aerial Photo, Inc.	311-3-55	21, 22	1"=300' (enlrg.)
10-21-1962	Continental Aerial Photo, Inc.	2382	98, 99	1"=300' (enlrg.)
9-10-1963	Continental Aerial Photo, Inc.	63175	120, 121	1"=300' (enlrg.)
5-8-1965	Continental Aerial Photo, Inc.	65200	215, 216	1"=300' (enlrg.)
1-30-1970	Continental Aerial Photo, Inc.	60-2	2:49, 50	1"=4,000'
1-30-1970	Continental Aerial Photo, Inc.	60-2	2:49, 50	1"=300' (enlrg.)
3-3-1971	Continental Aerial Photo, Inc.	71000	145, 146, 147	1"=2,000'
3-3-1971	Continental Aerial Photo, Inc.	71000	137, 138	1"=285' (enlrg.)
10-24-1975	Continental Aerial Photo, Inc.	75000	196, 197, 198	1"=2,000'
10-24-1975	Continental Aerial Photo, Inc.	75000	185, 186	1"=285' (enlrg.)
5-12-1979	Continental Aerial Photo, Inc.	FC-LA	4:193, 194, 195	1"=2,800'
1-2-1983	Continental Aerial Photo, Inc.	83001	199, 200, 201	1"=2,000'
1-27-1986	Continental Aerial Photo, Inc.	F	401, 402, 403	1"=2,800'
1-28-1986	Continental Aerial Photo, Inc.	F	502, 503, 504	1"=2,800'
7-7-1988	Continental Aerial Photo, Inc.		19143, 19144, 19159, 19160	1"=2,400'
5-25-1990	Continental Aerial Photo, Inc.	C81	8:38, 39, 40; 9:34, 35, 36	1"=2,400'
5-13-1993	Continental Aerial Photo, Inc.	C89	22:76, 77, 78	1"=2,000'



**APPENDIX B.3 ENCANTO PARK STORMWATER CAPTURE PROJECT  
EVALUATION**

## CONTENTS

---

<b>1.0 SITE DESCRIPTION AND EXISTING HYDROLOGY .....</b>	<b>3</b>
1.1.2 Land Use Distribution .....	6
1.2 Existing Water Quality .....	6
1.3 Preliminary Geotechnical Findings .....	6
1.3.1 Existing Soil Types .....	6
1.3.2 Ground Water .....	7
1.3.3 Geotechnical Summary .....	7
<b>2.0 BMP DESIGN COMPONENTS .....</b>	<b>7</b>
2.1 Site Layout .....	9
2.3 Diversion Structure Analysis .....	10
2.4 Pretreatment .....	10
2.5 Regional Structural BMP .....	11
<b>3.0 MONITORING PLAN .....</b>	<b>12</b>
3.1 Water Quality Monitoring.....	12
3.1.1 Flow Monitoring Methods .....	13
3.1.2 Composite Sampling Methods .....	13
3.2 Long-Term Performance Monitoring .....	13
<b>4.0 PERMITTING, SCHEDULE, AND COST ESTIMATE .....</b>	<b>13</b>
4.1 Environmental Documents and Permits.....	13
4.1.1 CEQA/NEPA.....	13
4.1.2 Local Construction Permits.....	14
4.2 Schedule .....	15
4.3 Cost Analysis .....	15
4.3.1 Construction Cost .....	15
4.3.3 Implementation Costs .....	17
4.3.4 Operations & Maintenance Cost .....	17
<b>EXHIBIT B.3.1 SITE PLAN .....</b>	<b>19</b>
<b>EXHIBIT B.3.2 FACT SHEET .....</b>	<b>21</b>

## LIST OF TABLES

---

Table 1. Land Use Distribution Summary.....	6
Table 2. Groundwater Wells in the Vicinity of the Site .....	7
Table 3. BMP Optimization Results.....	8

---

Table 4. Project Implementation Schedule..... 15  
Table 5. Construction Cost Estimate ..... 16  
Table 6. Total Project Cost ..... 17  
Table 7. Annual Estimated Operations & Maintenance Costs ..... 17

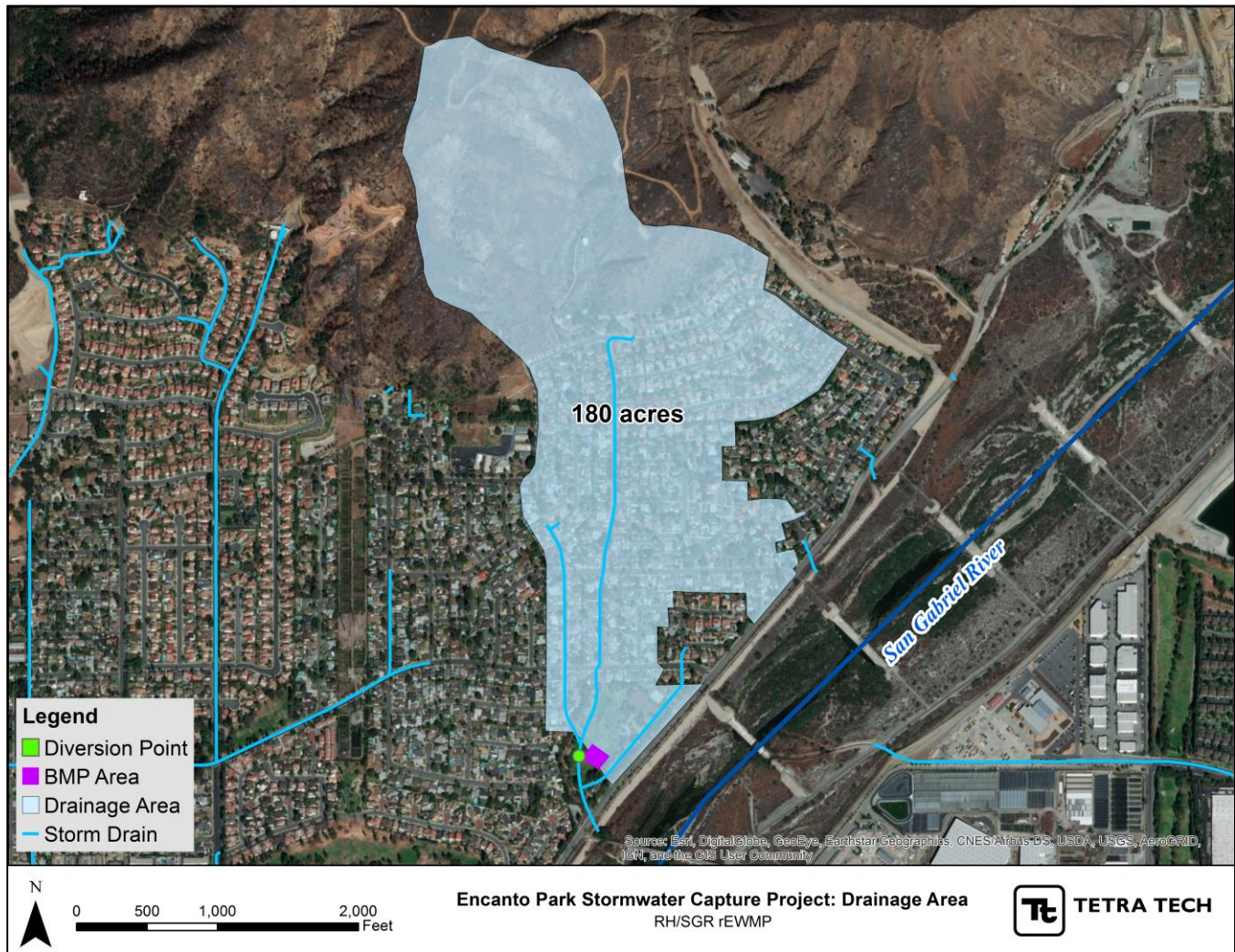
## LIST OF FIGURES

---

Figure 1. Project Drainage Area and Diversion Point.....3  
Figure 2. Near Western Park Boundary Looking Northeast Toward Baseball Diamond .....4  
Figure 3. Near Western Park Boundary Looking Towards Duarte Historical Museum .....4  
Figure 4. Grate Inlet at Downstream End of Natural Drainage Swale.....4  
Figure 5. Encanto Park Existing Site Conditions Map .....5  
Figure 6. Cost-Effectiveness Curve for Regional Projects within the San Gabriel River Drainage Area (note that modeled costs are relative – see engineering cost estimated in each appendix) .....8  
Figure 7. Rendering of Proposed Subsurface Structure at Encanto Park.....9  
Figure 8. Encanto Park Stormwater Capture Project Site Layout ..... 10  
Figure 9. Typical Hydrodynamic Separator ..... 11  
Figure 10. StormTrap Installation ad Bolivar Park BMP ..... 12

## 1.0 SITE DESCRIPTION AND EXISTING HYDROLOGY

Encanto Park is an 11.8-acre, multi-purpose recreational facility, located in the City of Duarte, which drains a 180-acre watershed area through the upstream storm drain system directly into the San Gabriel River. San Gabriel River runs parallel to Encanto Parkway which is parallel to the eastern edge of the park (**Figure 1**). Encanto Park has four sections: sports fields (**Figure 2**), a historical museum (**Figure 3**), boundary drainage swale and walking path, and covered seating. The sporting section contains a baseball field, grass soccer field, sand volleyball court, two tennis courts, and a basketball court. The historical is approximately 3,500 square feet building located at the south end of the park that is dedicated to commemorating the history of the City of Duarte. The boundary drainage swale is an enhance natural drainage feature that conveys small flows from site runoff to an inlet that connects to the storm drain system beneath Encanto Park (**Figure 4**). The park also has a walking path along the swale as an added amenity to enjoy the surrounding natural habitat and native animals. The covered gazebos that provide seating are located near the center of the park, separating the soccer and baseball field from the rest of the recreational amenities.



**Figure 1.** Project Drainage Area and Diversion Point



**Figure 2.** Near Western Park Boundary Looking Northeast Toward Baseball Diamond



**Figure 3.** Near Western Park Boundary Looking Towards Duarte Historical Museum



**Figure 4.** Grate Inlet at Downstream End of Natural Drainage Swale

A 72-inch RCP Los Angeles County Flood Control District (LACFCD) storm drain pipe (P.D. 263) drains along the western edge of the park, conveying dry and wet weather flows to discharge into the San Gabriel River near the southeast corner of the site. A 54-inch RCP City of Duarte storm drain pipe confluences with the 72-inch drain within the park limits near the center of the western boundary. Prior to the LACFCD drain discharge into the San Gabriel River, a 21-inch RCP City of Duarte storm drain joins this mainline at the southern corner of the site near the Duarte Historical Museum. The key determinants for placement of the proposed BMP within the park were the proximity to the storm drain, as well as minimizing impact on the functional use of the park amenities. The existing drainage conditions are shown in **Figure 5**.



**Figure 5.** Encanto Park Existing Site Conditions Map

### 1.1.2 Land Use Distribution

Understanding the tributary watershed land use can provide further insight into the best approach to be taken in the water quality assessment. The table provided below characterizes the land use distributions based on the Loading Simulation Program utilized in the water quality analysis performed for the feasibility study.

**Table 1.** Land Use Distribution Summary

Land Use	Area (acres)	Percent of Total Area
HD single-family residential	7.0	9%
Secondary roads	2.6	3%
Urban grass Irrigated	11.4	14%
Urban grass Non-irrigated	3.0	4%
Vacant steep slope B	34.0	42%
Vacant steep slope D	22.4	28%

## 1.2 EXISTING WATER QUALITY

---

For this study, the Los Angeles County Watershed Management Modeling System (WMMS) was used within the LSPC to simulate contaminant loading, runoff volume, and other baseline hydrology parameters. A more detailed description on the watershed modeling methodology and results that informed this feasibility study can be found in the revised Reasonable Assurance Analysis (RAA) in Attachment C of the rEWMP. The results from the revised RAA recommended using the critical water year as the critical condition for compliance, which was 2004 for the San Gabriel River. The limiting priority pollutant used in the water quality analysis based on the existing conditions was zinc.

The San Gabriel River Watershed has a drainage area of 71,511-acres. The Encanto Park Stormwater Capture Project is one of two regional BMP sites in the overarching feasibility study that is located within the San Gabriel River Watershed.

## 1.3 PRELIMINARY GEOTECHNICAL FINDINGS

---

At this stage in the EWMP process, geotechnical investigations were not performed. Preliminary research on the existing soils and groundwater conditions of the project area was performed to assess the feasibility of the project area as a regional BMP site. The geotechnical findings presented in this section are limited in nature, and will require subsurface soils explorations to verify feasibility.

### 1.3.1 Existing Soil Types

Based upon findings from a web soil survey provided by National Resource Conservation Service (NCRS), the typical soil profile at the site below the invert of the proposed BMP facility is very cobbly to extremely cobbly sand, with good drainage characteristics. NCRS’s interpretation of these soils correspond to Hydrologic Soil Group A. The capacity of the most limiting layer to transmit water is approximately 5.95 to 19.98 in/hr. The minimum required infiltration rate established by the Los Angeles County Department of Public Works (LACDPW) guidelines for in-site infiltration systems is 0.3 in/hr. The preliminary findings suggest that the project area has the potential to meet the minimum infiltration rate, but this cannot be determined until a subsurface investigation is performed and the applicable factors of safety are applied.

### 1.3.2 Ground Water

A review of the well data from the LACDPW database (<http://dpw.lacounty.gov/general/wells/>) and the Geotracker database (<http://geotracker.waterboards.ca.gov/gama/>) for nearby wells was conducted and indicate groundwater depths as summarized in **Table 2**. As shown, the shallowest groundwater depth was recorded at 26 feet in 1970. Based on this database search, preliminary results show that the groundwater has been deeper than 25 feet within the last 50 years. This research suggests that groundwater is not expected to impact the design and construction of the proposed BMP as the height of the proposed facility is only 5 feet.

**Table 2.** Groundwater Wells in the Vicinity of the Site

Well Identification	Monitoring Period	Approximate Location Relative to the Site	Shallowest Groundwater Depth (within the last 50 years)	Last Measured Depth
State #01N10W28M001S	Jul. 2011 to Jul. 2016	0.15 miles to the south	109 feet in Jul. 2016	109 feet in Jul. 2016
State #01N10W28M01 LACDPW Well ID: 4265A	Mar. 1970 to Oct. 2017	0.21 miles to the southwest	62.0 feet in Mar. 1970	131.5 feet in Oct. 2017
State #01N10W29A03 LACDPW Well ID: 4255A	Mar. 1928 to Jul. 2013	0.58 miles to the northwest	26.0 feet in Oct. 1987	46 feet in Jul. 2013
State #01N10W22P04 LACDPW Well ID: 4275F	Apr. 1988 to Aug. 2013	0.6 miles to the northeast	42.0 feet in May 1989	148.30 feet in Aug. of 2013
State #01N10W33C001S	Jul. 2011 to Jul 2016	0.65 miles to the southeast	282.5 feet in Jul. 2011	371.9 feet in Jul. 2016
State #01N10W29R02 LACDPW Well ID: 4256	Apr. 1968 to Jul 2013	0.65 miles to the southwest	198.3 feet in Feb. 1971	372 feet in Jul. 2013

### 1.3.3 Geotechnical Summary

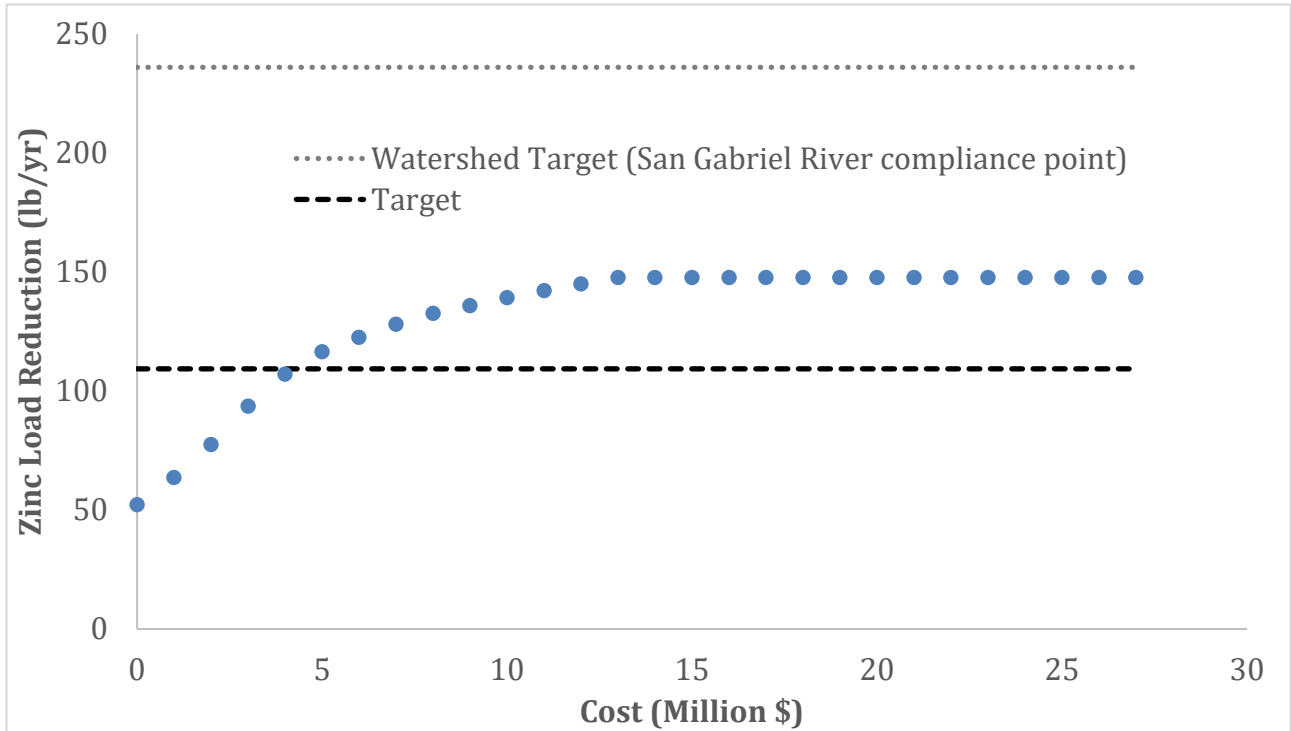
Based on the results of the preliminary desktop geotechnical investigation, it is Tetra Tech’s initial opinion that the proposed construction is feasible from a geotechnical standpoint. Once further soil exploration is performed, more definitive conclusions can be provided regarding the infiltration capabilities and groundwater constraints at this site.

## 2.0 BMP DESIGN COMPONENTS

The optimum BMP footprint and diversion rate was determined for the BMP site based on the long-term average annual zinc reduction, simulated using the EPA System for Urban Stormwater Treatment and Analysis Integration (SUSTAIN) model. To optimize the selection and placement of BMPs, SUSTAIN iteratively runs different combinations of BMP properties, varied within a specified range, to generate a cost-effectiveness curve (**Figure 6**). These curves show the additional load reductions from potential multi-benefit regional project configurations, beyond that already achieved from redevelopment projects and MCMs. The recommended BMP sizes and diversion rates to BMPs are based on the most cost-effective scenario.



The annual critical condition for load reduction requirements was determined by comparing the average rainfall within a ten-year period (2002-2011) that was closest to the 90<sup>th</sup> percentile average rainfall. The runoff treated by the BMP was then simulated over this ten-year period using critical water year determined for the San Gabriel River Watershed as 2004. Configurations of the multi-benefit regional projects which meet the required load reductions and exhibit the maximum performance for the given cost were reviewed and the recommended configuration is presented below (**Table 3**). Since the BMP optimization for San Gabriel River Watershed is based on all tributary BMPs, the achieved load reduction and cost presented below are associated with the implementation of both this project and the downstream Basin 3E Enhancements at the Santa Fe Spreading Grounds Project.



**Figure 6.** Cost-Effectiveness Curve for Regional Projects within the San Gabriel River Drainage Area (note that modeled costs are relative – see engineering cost estimated in each appendix)

**Table 3.** BMP Optimization Results

Parameter	Encanto Underground Storage
Length (ft)	75
Width (ft)	150
Height (ft)	5
BMP Capacity (ac-ft)	1.3
Diversion Rate (cfs)	3
Zinc Load Reduction (lbs/yr)	2.2 (0.26%)

\*Existing Wet Days Zn Load for the San Gabriel River was 852 lbs/yr.

## 2.1 SITE LAYOUT

The regional BMP system will divert runoff from the existing 72-inch RCP LACFCD storm drain within a concrete diversion structure, into an 18-inch diameter pipe, from the storm drain to a pretreatment device. Flows from the pretreatment device will enter and underground infiltration gallery via gravity. A rendering was created in **Figure 7** to show a conceptual picture of what the subsurface structural BMP system would look like. the site layout for is shown in **Figure 8**.



**Figure 7.** Rendering of Proposed Subsurface Structure at Encanto Park



Figure 8. Encanto Park Stormwater Capture Project Site Layout

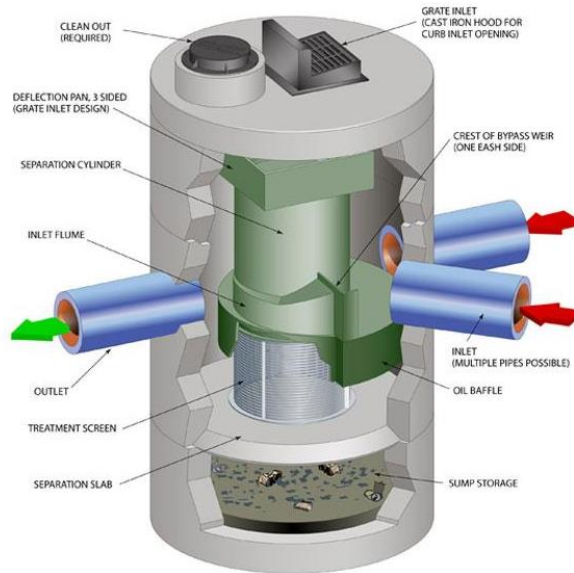
### 2.3 DIVERSION STRUCTURE ANALYSIS

The optimal flow rate determined from the water quality analysis was 3cfs. The diversion structure will be a concrete manhole or box with an internal weir and orifice sized to convey the 3cfs flow to the pretreatment device via gravity by an 18-inch RCP pipe.

### 2.4 PRETREATMENT

Stormwater runoff transports sediment, trash, and debris that can compromise the performance of stormwater facilities and pollute receiving waters. Pretreatment will be an integral component of the treatment strategies to extend the life of the proposed systems. Pretreatment is recommended in order to reduce the maintenance frequency of the BMP site stormwater facilities and to focus maintenance efforts to a concentrated area. The recommended pretreatment method is a hydrodynamic separator type pretreatment device. A typical hydrodynamic separator collects stormwater runoff on one or more sides of the structure then directs the water into a separation chamber where water begins swirling, forcing the particles out of the runoff. One-hundred percent of floatables and neutrally buoyant debris larger than the screen aperture is collected. Hydrodynamic

separators typically have an 80% removal rate if total suspended solids (TSS). With the chambered system, hydrocarbons float to the top of the water surface and are prevented from being transported downstream. The size of the unit will be selected based on the estimated sediment removal and the routine maintenance required. **Figure 9** represents a typical Contech CDS type hydrodynamic separator.



**Figure 9.** Typical Hydrodynamic Separator

*Source: Contech Engineered Solutions*

## 2.5 REGIONAL STRUCTURAL BMP

---

Underground storage/infiltration tanks provide initial stormwater detention and allow for infiltration where surface space is limited such as around paved streets, parking lots, and buildings. Precast concrete storage systems, such as the StormTrap, Oldcastle, and Jensen StormVault systems, made from durable, reinforced, and high-strength concrete would be the most appropriate modular unit for this project (vis-à-vis plastic modular units). They can be designed to exceed HS-20 loading, have varying depths of cover, and overcome buoyancy forces. Internal heights can vary to meet the desired storage volume. Cast-in-place structures are not considered a viable solution due to the time required to form, pour, and cure the structure. The additional time would create an additional burden on park operations and could extend the construction schedule.

The StormTrap Single Trap system allows for a maximum headroom of 5 feet and will provide water storage for the 1.3 ac-ft BMP volume. An example of a StormTrap Double Trap system that was installed at Bolivar Park in the City of Lakewood is shown in **Figure 10**. The Double Trap system allows for up to 11'-4" of headroom, which shows how versatile these modular units can be. The system will be configured to allow infiltration through the bottom of the system. The modular pieces are constructed offsite and delivered to the project site via truck and lifted into place with a crane. A typical day of installation may allow for 30 to 40 units to be placed in a day. The exact number of modules will depend on the selected vendor.



**Figure 10.** StormTrap Installation ad Bolivar Park BMP

## 3.0 MONITORING PLAN

There are two goals of a monitoring plan: 1) water quality monitoring to document the performance of the BMP and to demonstrate compliance with the EMWP, and 2) long-term monitoring to maintain and track performance and predict required maintenance.

### 3.1 WATER QUALITY MONITORING

To verify the performance of the regional structural BMPs, flow weighted composite samples should be collected at the inlet and the outlet of the system. The exact monitoring locations will be determined upon further project implementation. At minimum, the samples should be analyzed for Zinc. It is recommended that analysis include all priority pollutants identified in the RH/SGR Coordinated Integrated Monitoring Program (CIMP).

### 3.1.1 Flow Monitoring Methods

Flow at the BMP inlet location should be measured at pre-programmed intervals using an area-velocity bubbler (AVB) flow meter with an AVB sensor. Flow at the outlet should be measured using a Thel-Mar volumetric compound weir, which is capable of measuring low flows with a high degree of accuracy. A bubbler flow meter is recommended to measure flow depth behind the rubber dam in wet weather, which is then converted to a flow rate by the flow meter. The flow meter will continuously log the flow measurements at regular intervals during monitoring events.

### 3.1.2 Composite Sampling Methods

A flow-weighted composite sample is comprised of a series of sample aliquots collected over the course of a storm event where the sample aliquot frequency is determined by a constant incremental flow volume measured by the flow meter. To collect the sample, a flow meter is pre-programmed with a pacing volume. When the accumulated flow reaches the pacing volume, the flow meter will trigger an automated sampler to collect a sample aliquot. This process continues until the storm ends. The pacing volume is determined by storm event forecast and the anticipated total volume of runoff. Ideally, pacing volumes will be set to fill one composite bottle for the duration of rainfall to ensure sufficient sample volume for all analyses; however, stormwater runoff durations may be shorter or longer (or the rainfall intensity may be less or greater) than anticipated. If the rainfall duration is longer than that predicted, additional clean, empty bottles may be added to the sampling system. The automated sampler should log the sample information during the course of the monitoring event.

## 3.2 LONG-TERM PERFORMANCE MONITORING

---

Additional monitoring equipment, including water level meters and soil moisture sensors, are recommended to monitor and track the long-term performance of the regional structural BMPs. A continuous monitoring system can provide significant insight into the current and long-term performance of the BMP. A water level logger at the surface of the soil media can collect data on the ponding depth and ultimately determine the infiltration rate at the surface. This data can be used to determine the performance throughout a rain event and demonstrate any decreases in performance from the start of the rain event to the end; an overall reduction in infiltration could indicate an impending maintenance need allowing staff to predict when maintenance will be required rather than reacting to a visual indicator. A soil moisture sensor strategically placed in the BMP could also indicate if the system is performing as designed and identify any potential performance limitations.

## 4.0 PERMITTING, SCHEDULE, AND COST ESTIMATE

A preliminary cost estimate and schedule has been created to give the EWMP group an idea of the funds that will need to be secured to construct this regional BMP facility as well as validate that the BMP site will meet milestones set forth in the EWMP.

### 4.1 ENVIRONMENTAL DOCUMENTS AND PERMITS

---

Consultation with regulatory agencies and acquisition of permits is required before the project components can be constructed. The following sections summarize regulatory permits and approvals relevant to the project.

#### 4.1.1 CEQA/NEPA

A governmental agency is required to comply with California Environmental Quality Act (CEQA) procedures when the agency proposes to carry out or approve the activity/project. CEQA considers a “project” to be the whole of an action, which has a potential for resulting in either a direct physical change in the environment, or a reasonably foreseeable indirect physical change in the environment. The preparation of an Initial Study (IS) is typically the

first step for projects determined not to be exempt from CEQA requirements. Initial Studies allow decision-makers the opportunity to review a proposed project and to make an environmental determination recommending the follow-on CEQA document. Initial Studies consider all phases of project planning, implementation, and operation and utilize the CEQA Guidelines IS Checklist form that covers 17 environmental resources topics. If the IS identifies that there is no substantial evidence that the project may have a significant impact on the environment (without or with mitigation) then a Negative Declaration (ND) or Mitigated Negative Declaration (MND) may be prepared. In the unlikely event the IS identifies that the project may have a significant impact on the environment, then an Environmental Impact Report (EIR) would be required. A description of investigations that may be required are included below.

Compliance with the National Environmental Policy Act (NEPA) would be required if there is a federal nexus (such as federal funding). In addition, the project will need to comply with the implementing procedures of the applicable federal agency.

#### **4.1.1.1 Historical Resources**

The Historical Resources assessment will investigate the occurrence of historically significant areas within the vicinity of a proposed project site, namely sites listed on or eligible for designation by the California Register of Historical Resources (CRHR). A resource should be considered a historical resource if it has previously been identified as significant in a historical resources survey.

If a Lead Agency is unsure about a resource, they should consider hiring a professional historian or archeologist who meets the Secretary of the Interior Standards Professional Qualifications for History, Architectural History, or Archeology. However, CEQA ultimately delegates final authority to the Lead Agency to determine if a resource is historically significant or not (CEQA Case Studies).

Similar projects within recent years to the submission of this report have identified historical wheat farms from the 1870s and shipper centers from the 1920s, which had no official historical designations.

#### **4.1.1.2 Archaeological Resources**

Investigations by institutions such as The Native American Heritage Commission's search of the Sacred Lands Inventory will likely be required for full compliance. Further assessments for isolated artifacts or stream or topographical formations may also indicate the presence of subsurface prehistoric archaeological resources during excavation.

#### **4.1.1.3 Paleontological Resources**

Paleontological records may be assessed for records of known vertebrate fossils within the proposed project areas, as well as within older, sedimentary deposits.

#### **4.1.1.4 Burial Sites**

An investigation of known burial sites will occur prior to construction. In the event that an unknown burial site or human remains are found during excavation, mitigation should be implemented so that potential impacts remain at a less than significant level.

### **4.1.2 Local Construction Permits**

The City of Duarte may require building and grading permits for construction of this design. Traffic control will play an integral role in construction of the facility and the impacts of hauling export soils from the project during the excavation phase.

## 4.2 SCHEDULE

---

An estimated project schedule is outlined in **Table 4**. The feasibility study will accomplish 10% level design. The design task includes predesign (30-60% design level) and final design (60-100% design).

**Table 4.** Project Implementation Schedule

Task	Start	Finish
Feasibility Study	9/30/2022	3/30/2023
Design	3/30/2023	3/30/2024
Environmental Documentation (IS/MND) & Permitting	3/30/2023	9/30/2024
Bid & Award	9/30/2024	3/30/2025
Construction	3/30/2025	9/30/2026

## 4.3 COST ANALYSIS

---

The cost analysis is utilized as a tool to ensure the preliminary design is within the amount of funds available to the project. If the cost analysis indicates that the project is not feasible, then the design will need to be adjusted to bring it within the project budget, while still meeting the project goals. The cost analysis was developed using various sources of information, as well as the Cost Estimator’s judgement. A summary of the total costs will be provided after the construction and implementation cost discussion.

### 4.3.1 Construction Cost

The construction costs entail various components of the projects that a Contractor would construct for the City. Construction costs do not include items of work not directly performed by the Contractor, such as a City’s construction management during construction. The construction costs were developed using various source of cost information. Unit costs were based on Caltrans historical data and RSMeans cost data. All costs were approximately adjusted to 2018 dollars based respectively on the Caltrans Construction Cost Index and RSMeans Historical Cost Index. The estimated capital construction costs for the proposed BMP are listed in **Table 5**.



**Table 5. Construction Cost Estimate**

ITEM NO	DESCRIPTION	QUANTITY	UNIT	UNIT PRICE	TOTAL
<b>Diversion, Pretreatment, and Conveyance</b>					<b>\$252,125</b>
1	Diversion Structure	1	EA	\$150,000.00	\$150,000
2	Actuated Valve and Vault	1	EA	\$25,000.00	\$25,000
3	Pretreatment Device (3 cfs)	1	EA	\$40,000.00	\$40,000
4	Piping to Pretreatment (18" RCP)	30	LF	\$275.00	\$8,250
5	Piping to Storage (18" RCP)	30	LF	\$275.00	\$8,250
6	Excavation and Hauling for Conveyance Pipe	125	CY	\$45.00	\$5,625
7	Outlet Structure (connection to SD)	1	EA	\$15,000.00	\$15,000
<b>Pump Station and Conveyance</b>					<b>\$280,625</b>
8	Dry-Weather Pump Station (1.5 CFS)	1	EA	\$200,000.00	\$200,000
9	Electical Service, Controls, and Instrumentation	1	LS	\$60,000.00	\$60,000
10	18" RCP to Pump Station	75	LF	\$275.00	\$20,625
<b>Storage &amp; Treatment</b>					<b>\$836,010</b>
11	Excavaion for BMP	4,000	CY	\$15.00	\$60,000
12	Backfill, Fine Grading, and Compaction	1,900	CY	\$25.00	\$47,500
13	Hauling	2,100	CY	\$30.00	\$63,000
14	Underground Storage Tank (1.3 acre-feet)	2,100	CY	\$270.00	\$567,000
15	Install Units	520	EA	\$100.00	\$52,000
16	Subgrade (6" Stone Base with 2' Overhang Around Perimeter)	217	CY	\$30.00	\$6,510
17	Maintenace Holes	4	EA	\$10,000.00	\$40,000
<b>SUBTOTAL</b>					<b>\$1,368,760</b>
18	Mobilization/Demobilization (5% of Subtotal)				\$68,438
19	Estimating Contingency (25% of Subtotal)				\$342,190
<b>TOTAL COST</b>					<b>\$1,779,388</b>
<p>Notes:</p> <ol style="list-style-type: none"> <li>1 This is an estimate only. These figures are supplied as a guide. Tetra Tech is not responsible for fluctuation in cost of material, labor or components, or unforeseen contingencies.</li> <li>2 Estimate does not include surface (non-water quality) features.</li> <li>3 Estimated costs provided for construction bid items only. For example, estimates for materials testing, staking, and construction management are not included.</li> <li>4 Unit costs are based on Caltrans historical cost data and RS Means 2008 cost data where available. The costs are approximately adjusted to 2018 dollars based on the Caltrans Construction Cost Index and RS Means Historical Cost Indexes, respectively.</li> <li>3 Estimated does not include the cost for shoring.</li> </ol>					

### 4.3.3 Implementation Costs

Project implementation costs include all the necessary items to provide a finished product. Costs include feasibility study, preliminary design, final design, environmental documentation and permitting, construction management, construction, and post construction work. The estimated project delivery costs are typically based on a percentage of the construction cost for predesign, design, and construction management. The project implementation subtotal and total capital construction cost is provided in **Table 6**.

**Table 6.** Total Project Cost

Item Description	Cost
Feasibility Study (15% of Construction)	\$266,908
Preliminary Design (3.5% of Construction)	\$62,279
Final Design (10% of Construction)	\$177,939
Environmental Documentation & Permitting	\$17,795
Construction Management (10% of Construction)	\$177,939
<b>SUBTOTAL</b>	<b>\$702,860</b>
Construction Cost	\$1,779,388
<b>Capital Cost TOTAL</b>	<b>\$2,482,248</b>

### 4.3.4 Operations & Maintenance Cost

The operations and maintenance cost estimates were developed on the basis that a service contractor would maintain the various components of the system. Operation of the system during wet weather and dry weather events will be managed by the City. Operations of the diversion structure will incorporate coordination and notifications to the Los Angeles County Flood Control District to ensure that there will be no effect to the flood control conveyance system operation. **Table 7** estimates annual costs for typical operations and maintenance activities, not including the cost of long-term monitoring.

**Table 7.** Annual Estimated Operations & Maintenance Costs

Description	Frequency	No. of Times per Year	Unit Price	Total
<b>Diversion</b>				
Diversion System – Inspection and Cleaning	Monthly	12	\$250	\$6,000
Pretreatment Device - Vacuum	Monthly	12	\$250	\$3,000
Vacuum Truck Rental	Monthly	12	\$550	\$6,000
<b>Pump Station</b>				
Dry Season Inspection and Cleaning	Monthly	6	\$500	\$3,000
Wet Season Inspection and Cleaning	Monthly	6	\$500	\$3,000
Valve Maintenance	As-Needed	n/a	\$1000	\$1,000

Encanto Park Stormwater Capture Project

---

Electrical Usage	Monthly	12	\$460	\$5,520
Control Panel Maintenance	As-needed	1	\$1,000	\$1,000
Pump Replacement	Every 20 years	n/a	\$25,500	\$1,275
<b>Storage</b>				
Dry Season Inspection and Cleaning	Monthly	6	\$4,000	\$12,000
Wet Season Inspection and Cleaning	Monthly	6	\$4,000	\$12,000
<b>TOTAL</b>				<b>\$53,795</b>

---

**EXHIBIT B.3.1 SITE PLAN**

CITY OF DUARTE  
ENCANTO PARK STORMWATER CAPTURE PROJECT



PLAN VIEW  
(See Fact Sheet for Additional Details)

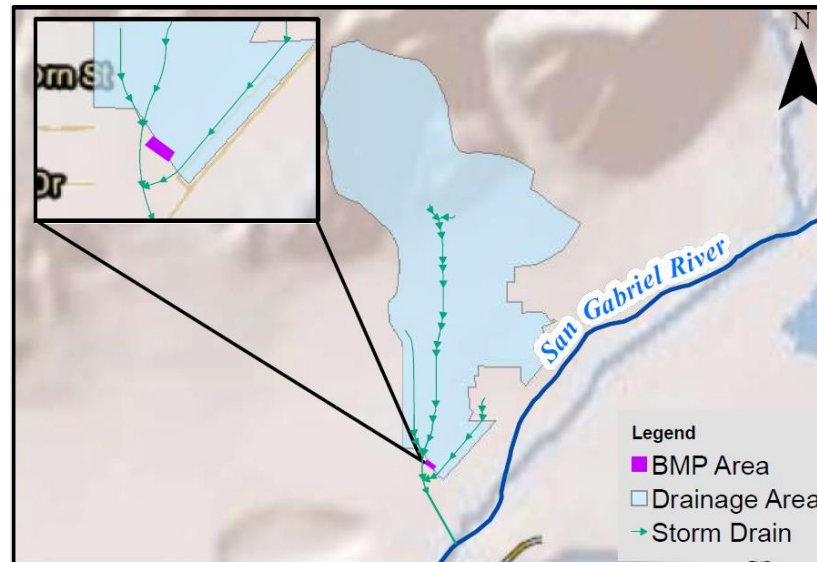


**EXHIBIT B.3.2 FACT SHEET**

**EXISTING SITE CONDITIONS**



**DRAINAGE AREA**



**DRAINAGE CHARACTERISTICS**

DRAINAGE AREA (acres)	180
HYDROLOGIC SOIL GROUP	D
APPROX. DEPTH TO GROUNDWATER (ft)	131.5
SOIL DESCRIPTION	Well-drained
MODELED AVERAGE ANNUAL RUNOFF VOLUME (ac-ft)	31.53

**BMP CHARACTERISTICS**

LOCATION: CITY OF DUARTE

LAT: 34° 8'37.97"N  
 LONG: 117°56'16.29"W

**Proposed BMP Description:** This proposed BMP for this project would divert runoff from an existing 72-inch LACFCD storm drain just south of its junction with City of Duarte's existing 54-inch storm drain. Pretreatment would be provided to capture gross solids and reduce maintenance frequency. The proposed BMP would provide a 1.3 acre-feet underground infiltration gallery or cistern to fully capture the design storm. A return line is proposed as an overflow to return treated water back into the existing 72-inch storm drain that outlets to the San Gabriel River.

**Project Benefits:**

- Groundwater recharge
- Flood control benefits
- Water quality improvements to the San Gabriel River
- Dry weather flow elimination
- Trash Capture

**Encanto Park Field – Location of proposed Subsurface Structure (from SW looking NE)**



**Existing Drainage Basin and Storm Drain Inlet at South End of Park (from NE looking SW)**



**Close Up of Existing Grate Inlet (Circled in Red to Left) from Natural Channel to SD (from SE looking NW)**

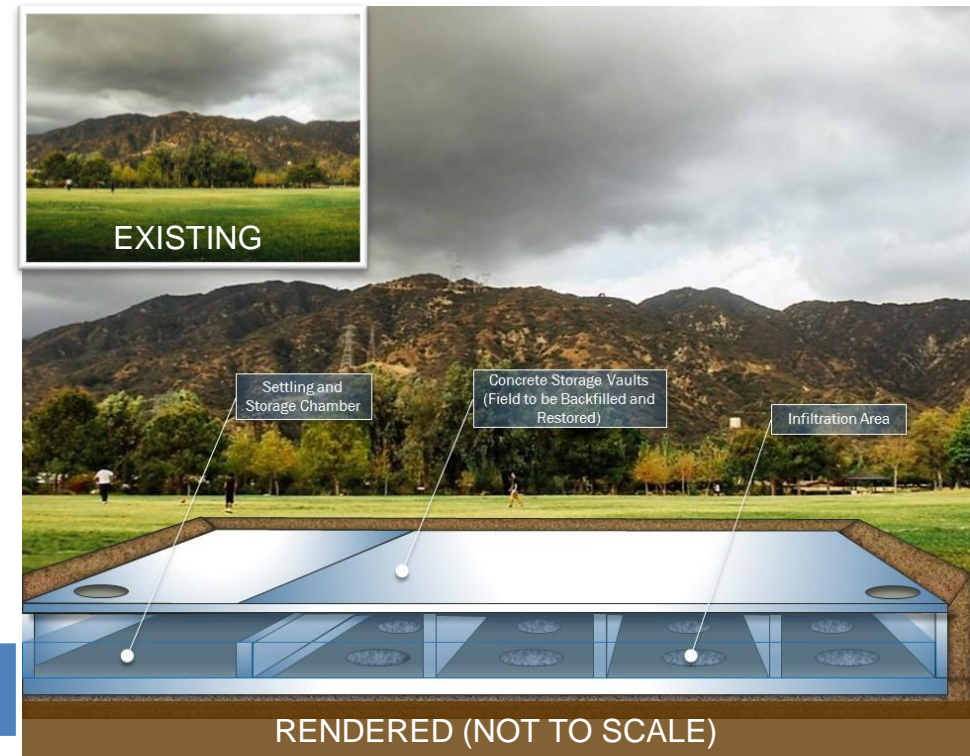


**PROPOSED CONCEPTUAL SITE LAYOUT**



**PLANNING-LEVEL COST ESTIMATE**

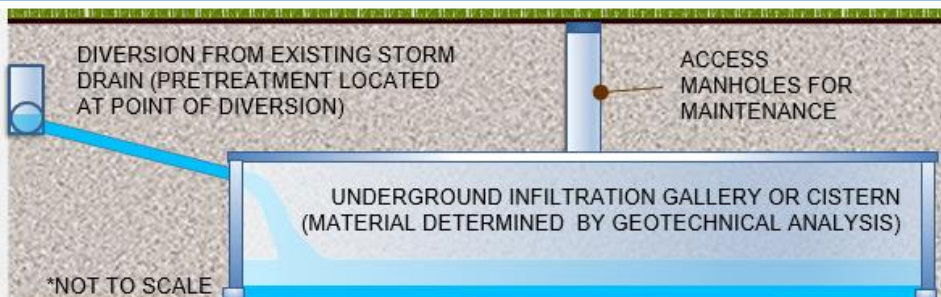
DESCRIPTION	TOTAL COST
Diversion, Pretreatment, and Conveyance	\$252,125
Pump Station and Conveyance	\$280,625
Storage and Treatment	\$836,010
<b>SUBTOTAL</b>	<b>\$1,368,760</b>
Mobilization/Demobilization (5% of Subtotal)	\$68,438
Estimating Contingency (25% of Subtotal)	\$342,190
<b>TOTAL COST</b>	<b>\$1,779,388</b>



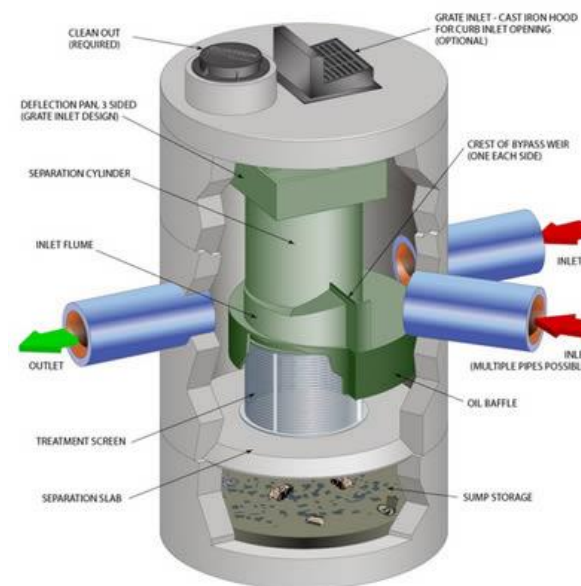
**TYPICAL STORMTRAP SUBSURFACE SYSTEM**



**CONCEPTUAL CROSS SECTION**



**TYPICAL HYDRODYNAMIC SEPARATOR PRETREATMENT DEVICE (Source: Contech)**



**PROJECT CHARACTERISTICS**

Zinc Reduction Achieved (Note: this project is nested; % Zn reduction contingent upon downstream project)	64.3 lb/yr (7.5%)
Design Diversion Rate (cfs)	3 cfs
Estimated Subsurface Storage Footprint (sq-ft)	11,250 sq-ft
Estimated Subsurface Storage Capacity (ac-ft)	1.3 ac-ft
Estimate Annual Groundwater Recharge (ac-ft/yr)	17.6 ac-ft/yr



**APPENDIX B.4 BASIN 3E ENHANCEMENTS AT SANTA FE SPREADING  
GROUNDS PROJECT EVALUATION**

## CONTENTS

---

<b>1.0 SITE DESCRIPTION AND EXISTING HYDROLOGY</b> .....	<b>3</b>
1.1.1 Land Use Distribution .....	6
1.2 Existing Water Quality .....	6
1.3 Preliminary Geotechnical Findings .....	6
1.3.1 Existing Soil Types .....	7
1.3.2 Ground Water .....	7
1.3.3 Geotechnical Summary .....	7
<b>2.0 BMP DESIGN COMPONENTS</b> .....	<b>7</b>
2.1 Site Layout .....	9
2.2 Energy Dissipation for Large Flows .....	10
2.3 Pretreatment .....	10
2.4 Regional Storage and Infiltration.....	11
<b>3.0 MONITORING PLAN</b> .....	<b>12</b>
3.1 Water Quality Monitoring.....	12
3.1.1 Flow Monitoring Methods .....	12
3.1.2 Composite Sampling Methods .....	12
3.2 Long-Term Performance Monitoring .....	12
<b>4.0 PERMITTING, SCHEDULE, AND COST ESTIMATE</b> .....	<b>13</b>
4.1 Environmental Documents and Permits.....	13
4.1.1 CEQA/NEPA.....	13
4.1.2 Local Construction Permits.....	14
4.2 Schedule .....	14
4.3 Cost Analysis .....	14
4.3.1 Construction Cost .....	14
4.3.2 Implementation Costs.....	16
4.3.3 Operations & Maintenance Cost .....	16
<b>EXHIBIT B.4.1 SITE PLAN</b> .....	<b>17</b>
<b>EXHIBIT B.4.2 FACT SHEET</b> .....	<b>19</b>

## LIST OF TABLES

---

Table 1. Land Use Distribution Summary.....	6
Table 2. Groundwater Wells in the Vicinity of the Site .....	7
Table 3. BMP Optimization Results.....	8

---

Table 4. Project Implementation Schedule..... 14  
Table 5. Construction Cost Estimate ..... 15  
Table 6. Total Project Cost ..... 16  
Table 7. Annual Estimated Operation & Maintenance Costs ..... 16

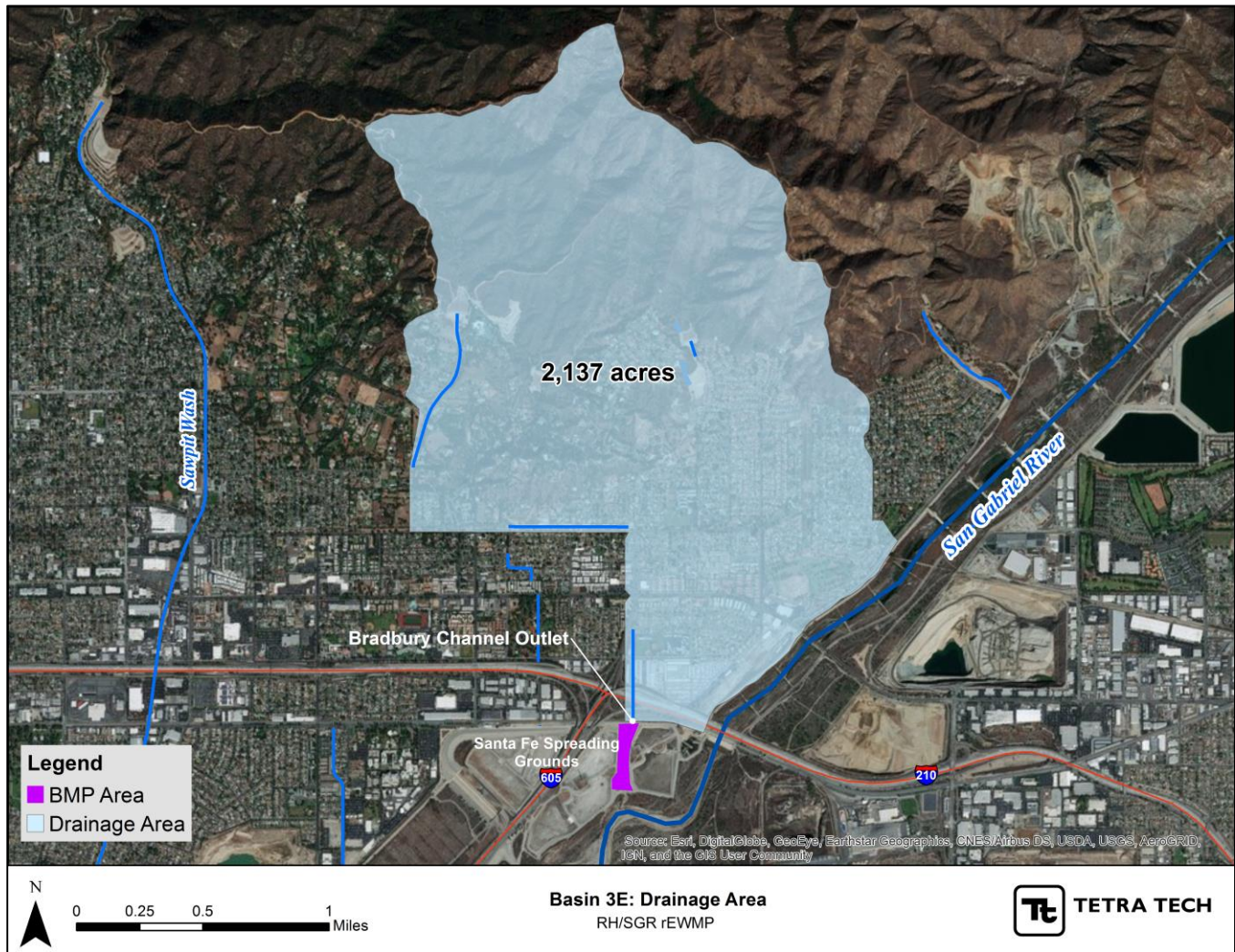
## LIST OF FIGURES

---

Figure 1. Project Drainage Area and Diversion Point.....3  
Figure 2. Basin 3E Looking from South (at Gate Valves) to North.....4  
Figure 3. Santa Fe Spreading Grounds Operational Map (LACFCD) .....4  
Figure 4. Bradbury Channel Outlet to Basin 3E with Standing Water (Looking from North to South) .....5  
Figure 5. Basin 3E Outlet Gate Values with 48-Inch CMP Pipes.....5  
Figure 6. Cost-Effectiveness Curve for Regional Projects within the San Gabriel River Drainage Area (note that modeled costs are relative – see engineering cost estimated in each appendix) .....8  
Figure 7. Rendering of Basin 3E Enhancements at Santa Fe Spreading Grounds .....9  
Figure 8. Basin 3E Enhancements at Santa Fe Spreading Grounds Site Layout..... 10  
Figure 9. Caltrans Austin Sand Filter Basin ..... 11  
Figure 10. Typical Subsurface Cross Section ..... 11

## 1.0 SITE DESCRIPTION AND EXISTING HYDROLOGY

Basin 3E is one of five spreading basins at the Santa Fe Spreading Grounds (SFSG) east of the 605 freeway and south of the 210 freeway. There are three additional spreading basins west of the 605 freeway. Bradbury Channel is a Los Angeles County Flood Control District (LACFCD) owned and operated channel, which drains approximately 2,137 acres of tributary area from the Cities of Bradbury and Duarte along with the Angeles National Forest to the San Gabriel River (**Figure 1**). Bradbury Channel transitions from an RCB to a 12-foot wide, 18-foot high open concrete channel. Prior to its outlet into the San Gabriel River (SGR), these flows are conveyed through Basin 3E at the SFSG (**Figure 2**). At the southern end of the basin there are three existing 48-inch CMP gate valves that control the outflow from Basin 3E to either Basin 5E, or to the SGR. In the current condition, only the valve to the San Gabriel River is open. The Operational Plan for the SFSG has been provided in **Figure 3**.



**Figure 1.** Project Drainage Area and Diversion Point

Basin 3E Enhancements at Santa Fe Spreading Grounds Project



Figure 2. Basin 3E Looking from South (at Gate Valves) to North

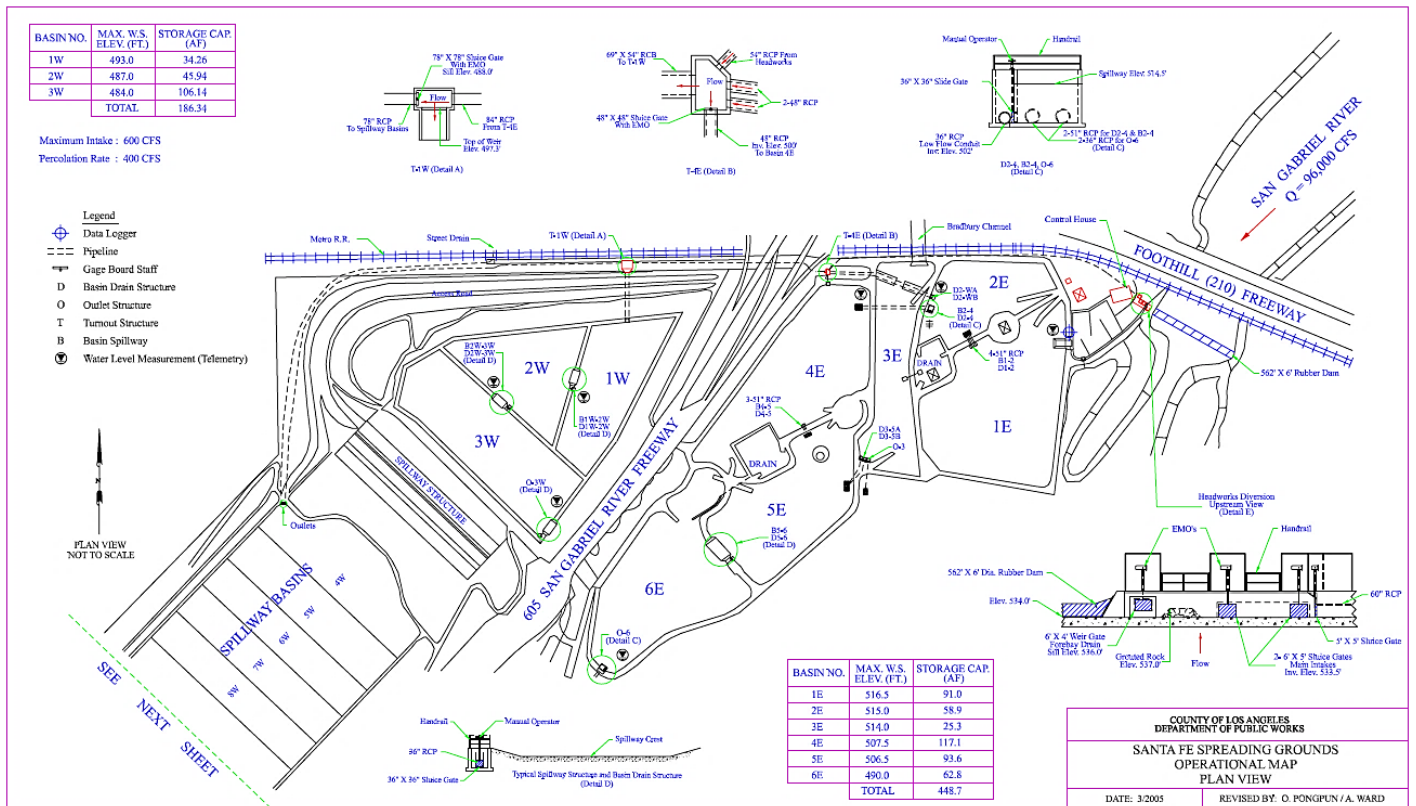


Figure 3. Santa Fe Spreading Grounds Operational Map (LACFCD)

Although Basin 3E is located at the SFSG, it is not operated or maintained like the surrounding spreading grounds. The original grading plans show that Basin 3E was designed with a deeper section of the basin near the Bradbury Channel inlet, most likely to capture sediment. Based on the nature of the catchment area that the channel conveys, there has been significant sediment buildup. The sediment has decreased infiltration capacities of the soil, and has in turn created pools of stagnant water (**Figure 4**). This has caused the maintenance division to grade a ditch down the center of the basin to facilitate dry weather flow conveyance to the SGR outlet (**Figure 5**).



**Figure 4.** Bradbury Channel Outlet to Basin 3E with Standing Water (Looking from North to South)



**Figure 5.** Basin 3E Outlet Gate Values with 48-Inch CMP Pipes

### 1.1.1 Land Use Distribution

Understanding the tributary watershed land use can provide further insight into the best approach to be taken in the water quality assessment. The table provided below characterizes the land use distributions based on the Loading Simulation Program utilized in the water quality analysis performed for the feasibility study.

**Table 1.** Land Use Distribution Summary

Land Use	Area (acres)	Percent of Total Area
Agriculture moderate slope D	24.6	2%
Commercial	15.4	1%
HD single-family residential	111.5	10%
Industrial	60.6	5%
Institutional	25.7	2%
LD single-family residential moderate slope	2.7	0%
LD single-family residential steep slope	2.0	0%
Multifamily residential	19.7	2%
Secondary roads	64.7	6%
Transportation	21.2	2%
Urban grass Irrigated	336.5	29%
Urban grass Non-irrigated	120.5	10%
Vacant moderate slope B	0.5	0%
Vacant moderate slope D	9.9	1%
Vacant steep slope B	188.5	16%
Vacant steep slope C	0.6	0%
Vacant steep slope D	153.4	13%

## 1.2 EXISTING WATER QUALITY

For this study, the Los Angeles County Watershed Management Modeling System (WMMS) was used within the LSPC to simulate contaminant loading, runoff volume, and other baseline hydrology parameters. A more detailed description on the watershed modeling methodology and results that informed this feasibility study can be found in the revised Reasonable Assurance Analysis (RAA) in Attachment C of the rEWMP. The results from the revised RAA recommended using the critical water year as the critical condition for compliance, which was 2004 for the San Gabriel River. The limiting priority pollutant used in the water quality analysis based on the existing conditions was zinc.

The San Gabriel River Watershed has a drainage area of 71,511-acres. The Basin 3E Enhancements at the Santa Fe Spreading Grounds Project is one of two regional BMP sites in the overarching feasibility study that is located within the San Gabriel River Watershed.

## 1.3 PRELIMINARY GEOTECHNICAL FINDINGS

At this stage in the EWMP process, geotechnical investigations were not performed. Preliminary research on the existing soils and groundwater conditions of the project area was performed to assess the feasibility of the project area as a regional BMP site. The geotechnical findings presented in this section are limited in nature, and will require subsurface soils explorations to verify feasibility.

### 1.3.1 Existing Soil Types

Based upon findings from a web soil survey provided by National Resource Conservation Service (NCRS), the soils at the site are characterized as spits and quarries, with good drainage characteristics. NCRS's interpretation of these soils correspond to a Hydrologic Soil Group B. Based on the 400cfs percolation rate from the SFSG Operational Map for the entire spreading grounds facility, it can be assumed that Basin 3E will have similarly high infiltration rates once the sediment is removed from the bottom of the basin. The preliminary findings suggest that the project area has the potential infiltrate at a high rate, but this cannot be determined until a subsurface investigation is performed.

### 1.3.2 Ground Water

A review of the well data from the LACDPW database (<http://dpw.lacounty.gov/general/wells/>) and the Geotracker database (<http://geotracker.waterboards.ca.gov/gama/>) for nearby wells was conducted and indicate groundwater depths as summarized in **Table 2**. As shown, the shallowest groundwater depth was recorded at 128.2 feet in 2006. Based on this database search, preliminary results show that the groundwater has been deeper than 128 feet within the last 50 years. This research suggests that groundwater is not expected to impact the design and construction of the proposed BMP.

**Table 2.** Groundwater Wells in the Vicinity of the Site

Well Identification	Monitoring Period	Approximate Location Relative to the Site	Shallowest Groundwater Depth (within the last 50 years)	Last Measured Depth
State # 01N10W31A01 LACFCD Well ID: 4246	Sept. 1930 to Jul. 2013	0.34 miles to the northwest	128.2 feet in Sept. 2006	312 feet in Jul. 2013
State #01N10W29R02 LACFCD Well ID: 4256	Apr. 1968 to Jul. 2013	0.66 miles to the north	198.3 feet in Feb. 1971	372 feet in Jul. 2013

### 1.3.3 Geotechnical Summary

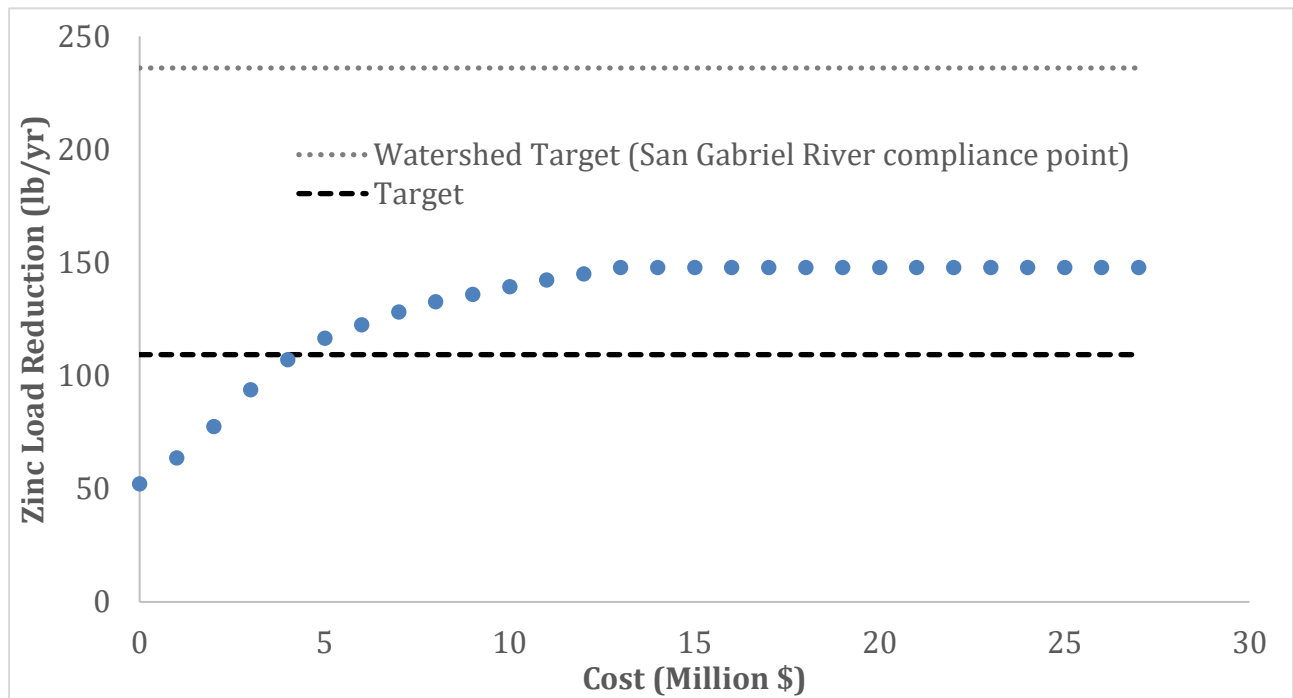
Based on the results of the preliminary desktop geotechnical investigation, it is Tetra Tech's initial opinion that the proposed construction is feasible from a geotechnical standpoint. Once further soil exploration is performed, more definitive conclusions can be provided regarding the infiltration capabilities and groundwater constraints at this site.

## 2.0 BMP DESIGN COMPONENTS

The optimum BMP footprint and diversion rate was determined for the BMP site based on the long-term average annual zinc reduction, simulated using the EPA System for Urban Stormwater Treatment and Analysis Integration (SUSTAIN) model. To optimize the selection and placement of BMPs, SUSTAIN iteratively runs different combinations of BMP properties, varied within a specified range, to generate a cost-effectiveness curve (**Figure 6**). These curves show the additional load reductions from potential multi-benefit regional project configurations, beyond that already achieved from redevelopment projects and MCMs. The recommended BMP sizes and diversion rates to BMPs are based on the most cost-effective scenario.



The annual critical condition for load reduction requirements was determined by comparing the average rainfall within a ten-year period (2002-2011) that was closest to the 90<sup>th</sup> percentile average rainfall. The runoff treated by the BMP was then simulated over this ten-year period using critical water year determined for the San Gabriel River Watershed as 2004. Configurations of the multi-benefit regional projects which meet the required load reductions and exhibit the maximum performance for the given cost were reviewed and the recommended configuration is presented below (**Table 3**). Since the BMP optimization for San Gabriel River Watershed is based on all tributary BMPs, the achieved load reduction and cost presented below are associated with the implementation of both this project and the upstream Encanto Park Stormwater Capture Project.



**Figure 6.** Cost-Effectiveness Curve for Regional Projects within the San Gabriel River Drainage Area (note that modeled costs are relative – see engineering cost estimated in each appendix)

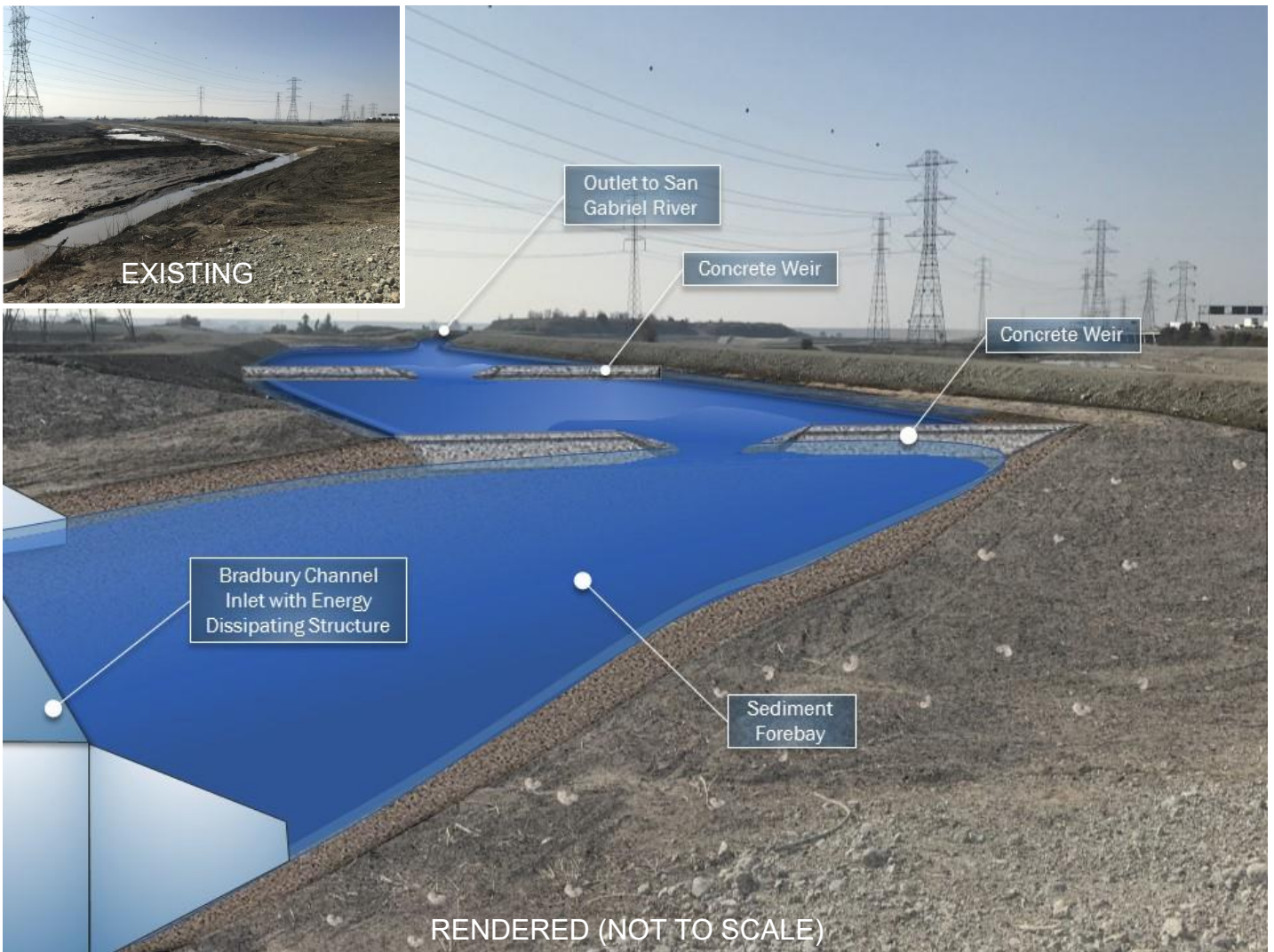
**Table 3.** BMP Optimization Results

Parameter	Basin 3E
Length (ft)	550
Width (ft)	180
Height (ft)	5
BMP Capacity (ac-ft)	11.4
Diversion Rate (cfs)	N/A
Zinc Load Reduction (lbs/yr)	62.1 (7.3%)
• Phase 1	24.6
• Phase 2	37.5

**Notes:** 1. Existing Wet Days Zn Load for the San Gabriel River was 852 lbs/yr.  
 2. Phase 2 zinc load reduction is dependent on construction of the upstream Encanto Park Stormwater Capture Project.

## 2.1 SITE LAYOUT

The regional BMP system will enhance the existing flood control detention basin at the SFSG by constructing a sediment forebay with an energy dissipating mechanism for pretreatment. Flows from the sediment basin will spill over a concrete weir to a secondary basin where water will be filtered through a sand filter media with a geotextile bottom and perforated underdrains to convey treated flows to the San Gabriel River. There will be a second concrete weir where overflow that will drain into a smaller basin that will provide additional treatment as well as utilize the downstream portion of the basin that is not needed for the water quality sizing. A rendering was created in **Figure 7** to show a conceptual picture of what the subsurface structural BMP system would look like. The site layout is shown in **Figure 8**.



**Figure 7.** Rendering of Basin 3E Enhancements at Santa Fe Spreading Grounds

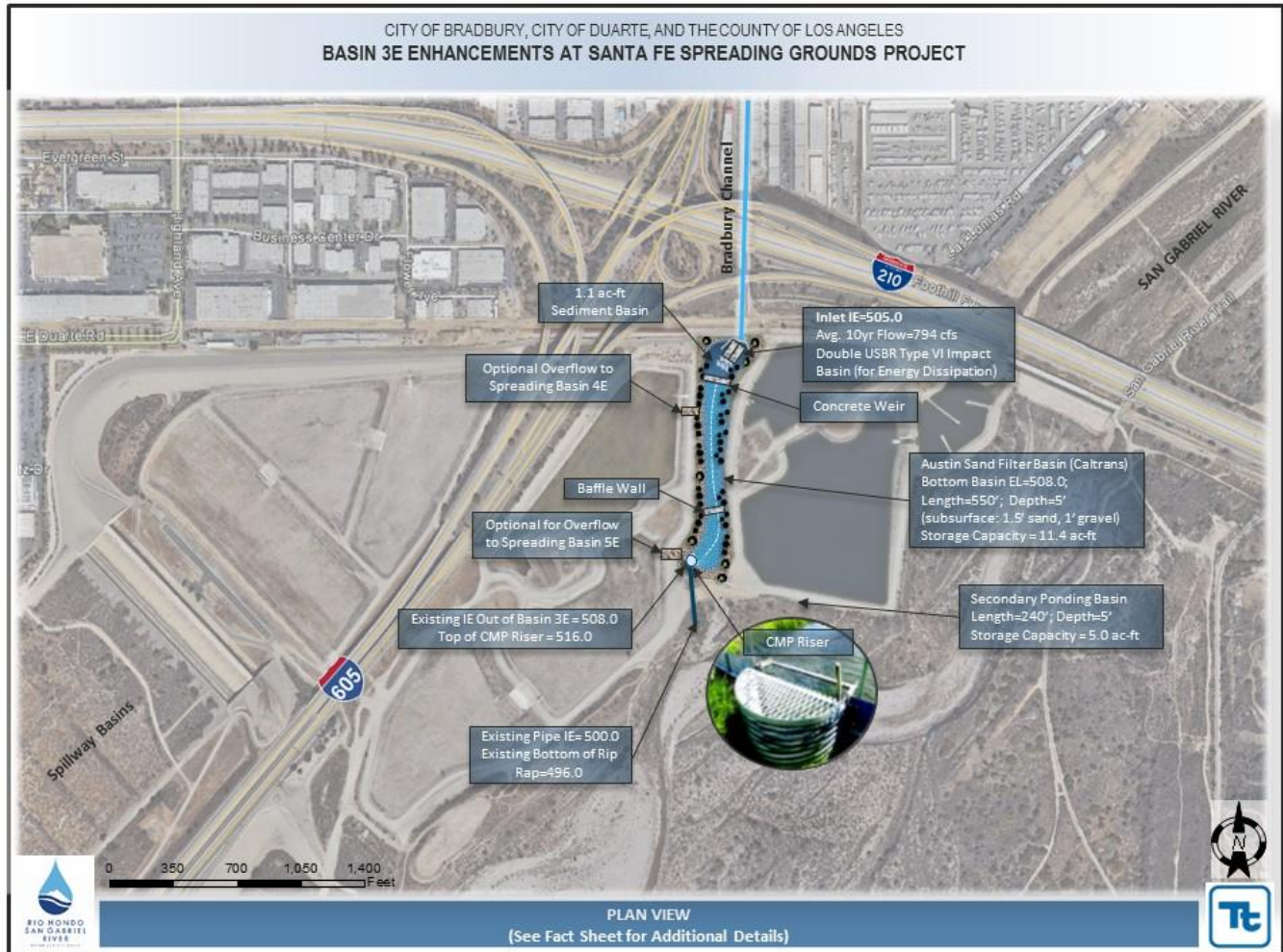


Figure 8. Basin 3E Enhancements at Santa Fe Spreading Grounds Site Layout

## 2.2 ENERGY DISSIPATION FOR LARGE FLOWS

This project is located at the outlet of a large 12-foot-wide by 18-foot-high concrete channel, and is conveying significant flows (approximately 794 cfs in wet weather) to the San Gabriel River. This concept does not propose to diver any flow, but will take the existing flow being conveyed by Bradbury Channel and provide treatment and recharge capacity. An energy dissipating structure, such as a USBR Type VI Impact Basin (or similar) will be constructed to decrease the velocity of the flows and allow for settling to take place for pretreatment as well as protect the concrete weir that will be constructed to separate the different basin sections.

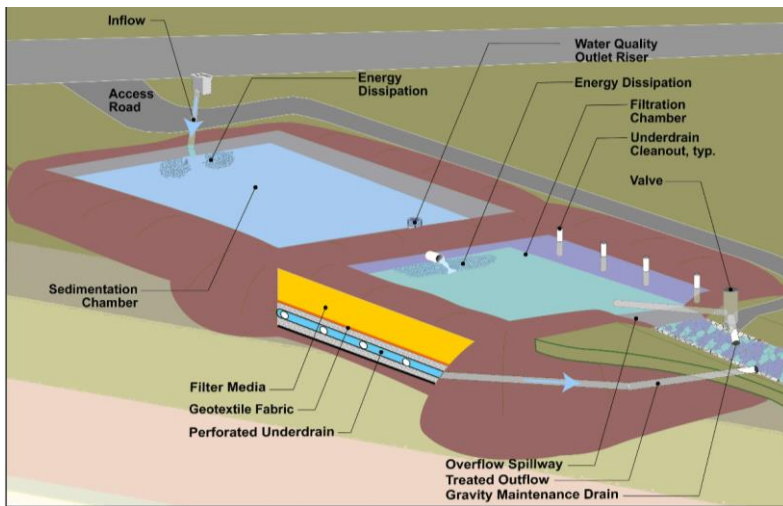
## 2.3 PRETREATMENT

Stormwater runoff transports sediment, trash, and debris that can compromise the performance of stormwater facilities and pollute receiving waters. Pretreatment will be an integral component of the treatment strategies to extend the life of the proposed systems. Pretreatment is recommended in order to reduce the maintenance frequency of the BMP site stormwater facilities and to focus maintenance efforts to a concentrated area. The recommended pretreatment method is a sediment forebay upstream of the BMP facility. The forebay should be

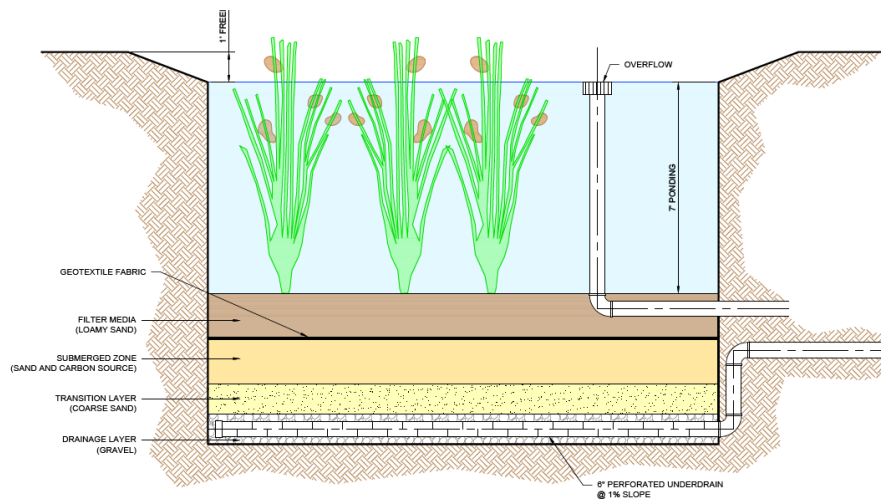
sized to contain about 10% of the total volume, which would be 1.1 ac-ft. The sediment basin will allow isolate gross sediments prior to entering the wetland. The sediment basin will increase the residence time, which will help settle coarse sediment particles and improve pollutant removal.

## 2.4 REGIONAL STORAGE AND INFILTRATION

The Basin 3E enhancements would require the existing basin to be dredged to remove the built-up sediment that has been accumulated over the years. The pretreatment sediment chamber will prevent much of the sediment from being transported to the BMP. Flows from the new sediment forebay will spill over into the first treatment basin which will have a volume of approximately 11.4 ac-ft. To encourage infiltration and convey cleaner water to the San Gabriel River, an Austin San Filter Type basin (Caltrans) will be constructed (**Figure 9**). The subsurface treatment mechanism is comprised of a 1.5-foot minimum sand filter layer, over a 1-foot minimum gravel layer with perforated underdrains collecting and conveying treated flow (**Figure 10**). An additional concrete weir will be constructed with overflow to a ponding basin of 5 ac-ft where infiltration into the groundwater table occur.



**Figure 9.** Caltrans Austin Sand Filter Basin



**Figure 10.** Typical Subsurface Cross Section

## 3.0 MONITORING PLAN

There are two goals of a monitoring plan: 1) water quality monitoring to document the performance of the BMP and to demonstrate compliance with the EMWP, and 2) long-term monitoring to maintain and track performance and predict required maintenance.

### 3.1 WATER QUALITY MONITORING

---

To verify the performance of the regional structural BMPs, flow weighted composite samples should be collected at the inlet and the outlet of the system. The exact monitoring locations will be determined upon further project implementation. At minimum, the samples should be analyzed for Zinc. It is recommended that analysis include all priority pollutants identified in the RH/SGR Coordinated Integrated Monitoring Program (CIMP).

#### 3.1.1 Flow Monitoring Methods

Flow at the BMP inlet location should be measured at pre-programmed intervals using an area-velocity bubbler (AVB) flow meter with an AVB sensor. Flow at the outlet should be measured using a Thel-Mar volumetric compound weir, which is capable of measuring low flows with a high degree of accuracy. A bubbler flow meter is recommended to measure flow depth behind the rubber dam in wet weather, which is then converted to a flow rate by the flow meter. The flow meter will continuously log the flow measurements at regular intervals during monitoring events.

#### 3.1.2 Composite Sampling Methods

A flow-weighted composite sample is comprised of a series of sample aliquots collected over the course of a storm event where the sample aliquot frequency is determined by a constant incremental flow volume measured by the flow meter. To collect the sample, a flow meter is pre-programmed with a pacing volume. When the accumulated flow reaches the pacing volume, the flow meter will trigger an automated sampler to collect a sample aliquot. This process continues until the storm ends. The pacing volume is determined by storm event forecast and the anticipated total volume of runoff. Ideally, pacing volumes will be set to fill one composite bottle for the duration of rainfall to ensure sufficient sample volume for all analyses; however, stormwater runoff durations may be shorter or longer (or the rainfall intensity may be less or greater) than anticipated. If the rainfall duration is longer than that predicted, additional clean, empty bottles may be added to the sampling system. The automated sampler should log the sample information during the course of the monitoring event.

### 3.2 LONG-TERM PERFORMANCE MONITORING

---

Additional monitoring equipment, including water level meters and soil moisture sensors, are recommended to monitor and track the long-term performance of the regional structural BMPs. A continuous monitoring system can provide significant insight into the current and long-term performance of the BMP. A water level logger at the surface of the soil media can collect data on the ponding depth and ultimately determine the infiltration rate at the surface. This data can be used to determine the performance throughout a rain event and demonstrate any decreases in performance from the start of the rain event to the end; an overall reduction in infiltration could indicate an impending maintenance need allowing staff to predict when maintenance will be required rather than reacting to a visual indicator. A soil moisture sensor strategically placed in the BMP could also indicate if the system is performing as designed and identify any potential performance limitations.

## 4.0 PERMITTING, SCHEDULE, AND COST ESTIMATE

A preliminary cost estimate and schedule has been created to give the EWMP group an idea of the funds that will need to be secured to construct this regional BMP facility as well as validate that the BMP site will meet milestones set forth in the EWMP.

### 4.1 ENVIRONMENTAL DOCUMENTS AND PERMITS

---

Consultation with regulatory agencies and acquisition of permits is required before the project components can be constructed. The following sections summarize regulatory permits and approvals relevant to the project.

#### 4.1.1 CEQA/NEPA

A governmental agency is required to comply with California Environmental Quality Act (CEQA) procedures when the agency proposes to carry out or approve the activity/project. CEQA considers a “project” to be the whole of an action, which has a potential for resulting in either a direct physical change in the environment, or a reasonably foreseeable indirect physical change in the environment. The preparation of an Initial Study (IS) is typically the first step for projects determined not to be exempt from CEQA requirements. Initial Studies allow decision-makers the opportunity to review a proposed project and to make an environmental determination recommending the follow-on CEQA document. Initial Studies consider all phases of project planning, implementation, and operation and utilize the CEQA Guidelines IS Checklist form that covers 17 environmental resources topics. If the IS identifies that there is no substantial evidence that the project may have a significant impact on the environment (without or with mitigation) then a Negative Declaration (ND) or Mitigated Negative Declaration (MND) may be prepared. In the unlikely event the IS identifies that the project may have a significant impact on the environment, then an Environmental Impact Report (EIR) would be required. A description of investigations that may be required are included below.

Compliance with the National Environmental Policy Act (NEPA) would be required if there is a federal nexus (such as federal funding). In addition, the project will need to comply with the implementing procedures of the applicable federal agency.

##### 4.1.1.1 Historical Resources

The Historical Resources assessment will investigate the occurrence of historically significant areas within the vicinity of a proposed project site, namely sites listed on or eligible for designation by the California Register of Historical Resources (CRHR). A resource should be considered a historical resource if it has previously been identified as significant in a historical resources survey.

If a Lead Agency is unsure about a resource, they should consider hiring a professional historian or archeologist who meets the Secretary of the Interior Standards Professional Qualifications for History, Architectural History, or Archeology. However, CEQA ultimately delegates final authority to the Lead Agency to determine if a resource is historically significant or not (CEQA Case Studies).

Similar projects within recent years to the submission of this report have identified historical wheat farms from the 1870s and shipper centers from the 1920s, which had no official historical designations.

##### 4.1.1.2 Archaeological Resources

Investigations by institutions such as The Native American Heritage Commission’s search of the Sacred Lands Inventory will likely be required for full compliance. Further assessments for isolated artifacts or stream or topographical formations may also indicate the presence of subsurface prehistoric archaeological resources during excavation.

### 4.1.1.3 Paleontological Resources

Paleontological records may be assessed for records of known vertebrate fossils within the proposed project areas, as well as within older, sedimentary deposits.

### 4.1.1.4 Burial Sites

An investigation of known burial sites will occur prior to construction. In the event that an unknown burial site or human remains are found during excavation, mitigation should be implemented so that potential impacts remain at a less than significant level.

## 4.1.2 Local Construction Permits

The City of Irwindale may require building and grading permits for construction of this design. Traffic control will play an integral role in construction of the facility and the impacts of hauling export soils from the project during the excavation phase.

## 4.2 SCHEDULE

---

An estimated project schedule is outlined in **Table 4**. The feasibility study will accomplish 10% level design. The design task includes predesign (30-60% design level) and final design (60-100% design).

**Table 4.** Project Implementation Schedule

Task	Start	Finish
Feasibility Study	3/30/2019	9/30/2019
Final Design	9/30/2019	9/30/2020
Environmental Documentation (IS/MND) & Permitting	9/30/2020	3/30/2022
Bid & Award	3/30/2022	9/30/2022
Construction - Phase 1	9/30/2022	9/30/2023
- Phase 2	9/30/2025	9/30/2026

## 4.3 COST ANALYSIS

---

The cost analysis is utilized as a tool to ensure the preliminary design is within the amount of funds available to the project. If the cost analysis indicates that the project is not feasible, then the design will need to be adjusted to bring it within the project budget, while still meeting the project goals. The cost analysis was developed using various sources of information, as well as the Cost Estimator's judgement. A summary of the total costs will be provided after the construction and implementation cost discussion.

### 4.3.1 Construction Cost

The construction costs entail various components of the projects that a Contractor would construct for the City. Construction costs do not include items of work not directly performed by the Contractor, such as a City's construction management during construction. The construction costs were developed using various source of cost information. Unit costs were based on Caltrans historical data and RSMeans cost data. All costs were

approximately adjusted to 2018 dollars based respectively on the Caltrans Construction Cost Index and RSMeans Historical Cost Index. The estimated capital construction costs for the proposed BMP are listed in **Table 5**

**Table 5.** Construction Cost Estimate

ITEM NO	DESCRIPTION	QUANTITY	UNIT	UNIT PRICE	TOTAL
<b>Bradbury Channel, Pretreatment, and Conveyance</b>					<b>\$547,700</b>
1	Sediment Basin Excavation & Hauling	2,000	CY	\$45.00	\$90,000
2	USBR Type VI Impact Basin	1	LS	\$400,000.00	\$400,000
3	Concrete Weir	277	CY	\$100.00	\$27,700
4	Sluice Gates for Connection to Spreading Basins	2	EA	\$15,000.00	\$30,000
<b>Storage &amp; Treatment</b>					<b>\$1,051,314</b>
5	Sand Filter Media	5,000	CY	\$45.00	\$225,000
6	Gravel Drainage Rock	3,333	CY	\$58.00	\$193,314
7	Excavation for Treatment Basin	11,667	CY	\$15.00	\$175,005
8	Dredge Secondary Ponding Basin (Remove Top 1' Layer)	2,333	CY	\$15.00	\$34,995
9	Hauling	14,000	CY	\$30.00	\$420,000
10	Retrofit Existing Outlet Structure	1	LS	\$3,000.00	\$3,000
<b>SUBTOTAL</b>					<b>\$1,599,014</b>
11	Mobilization/Demobilization (5% of Subtotal)				\$79,951
12	Estimating Contingency (25% of Subtotal)				\$399,754
<b>TOTAL COST</b>					<b>\$2,078,718</b>
<p>Notes:</p> <ol style="list-style-type: none"> <li>1 This is an estimate only. These figures are supplied as a guide. Tetra Tech is not responsible for fluctuation in cost of material, labor or components, or unforeseen contingencies.</li> <li>2 Estimate does not include surface (non-water quality) features.</li> <li>3 Estimated costs provided for construction bid items only. For example, estimates for materials testing, staking, and construction management are not included.</li> <li>4 Unit costs are based on Caltrans historical cost data and RS Means 2008 cost data where available. The costs are approximately adjusted to 2018 dollars based on the Caltrans Construction Cost Index and RS Means Historical Cost Indexes, respectively.</li> <li>4 This cost assumes that there is no soils contamination in the existing soils.</li> </ol>					



### 4.3.2 Implementation Costs

Project implementation costs include all the necessary items to provide a finished product. Costs include feasibility study, preliminary design, final design, environmental documentation and permitting, construction management, construction, and post construction work. The estimated project delivery costs are typically based on a percentage of the construction cost for predesign, design, and construction management. The project implementation subtotal and total capital construction cost is provided in **Table 6**.

**Table 6.** Total Project Cost

Item Description	Cost
Feasibility Study (15% of Construction)	\$311,808
Preliminary Design (3.5% of Construction)	\$72,755
Final Design (10% of Construction)	\$207,872
Environmental Documentation & Permitting	\$20,800
Construction Management (10% of Construction)	\$207,872
<b>SUBTOTAL</b>	<b>\$821,107</b>
Construction Cost	\$2,078,718
<b>Capital Cost TOTAL</b>	<b>\$2,899,825</b>

### 4.3.3 Operations & Maintenance Cost

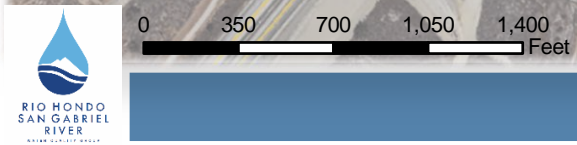
The operations and maintenance cost estimates were developed on the basis that a service contractor would maintain the various components of the system. Operation of the system during wet weather and dry weather events will be managed by the City. Operations of the diversion structure will incorporate coordination and notifications to the Los Angeles County Flood Control District to ensure that there will be no effect to the flood control conveyance system operation. **Table 7** estimates annual costs for typical operations and maintenance activities, not including the cost of long-term monitoring.

**Table 7.** Annual Estimated Operation & Maintenance Costs

Description	Frequency	No. of Times per Year	Unit Price	Total
Inspect Sediment Basin for Sediment Accumulation and Trash/Debris	Semi-annually	2	\$250	\$500
Remove Accumulated Trash and Debris in the Sediment Basin	Semi-annually	2	\$500	\$1,000
Remove Accumulated Sediment in the Forebay and Regrade	Every 5 Years	n/a	\$15,000	\$3,000
<b>TOTAL</b>				<b>\$4,500</b>

**EXHIBIT B.4.1 SITE PLAN**

CITY OF BRADBURY, CITY OF DUARTE, AND THE COUNTY OF LOS ANGELES  
**BASIN 3E ENHANCEMENTS AT SANTA FE SPREADING GROUNDS PROJECT**

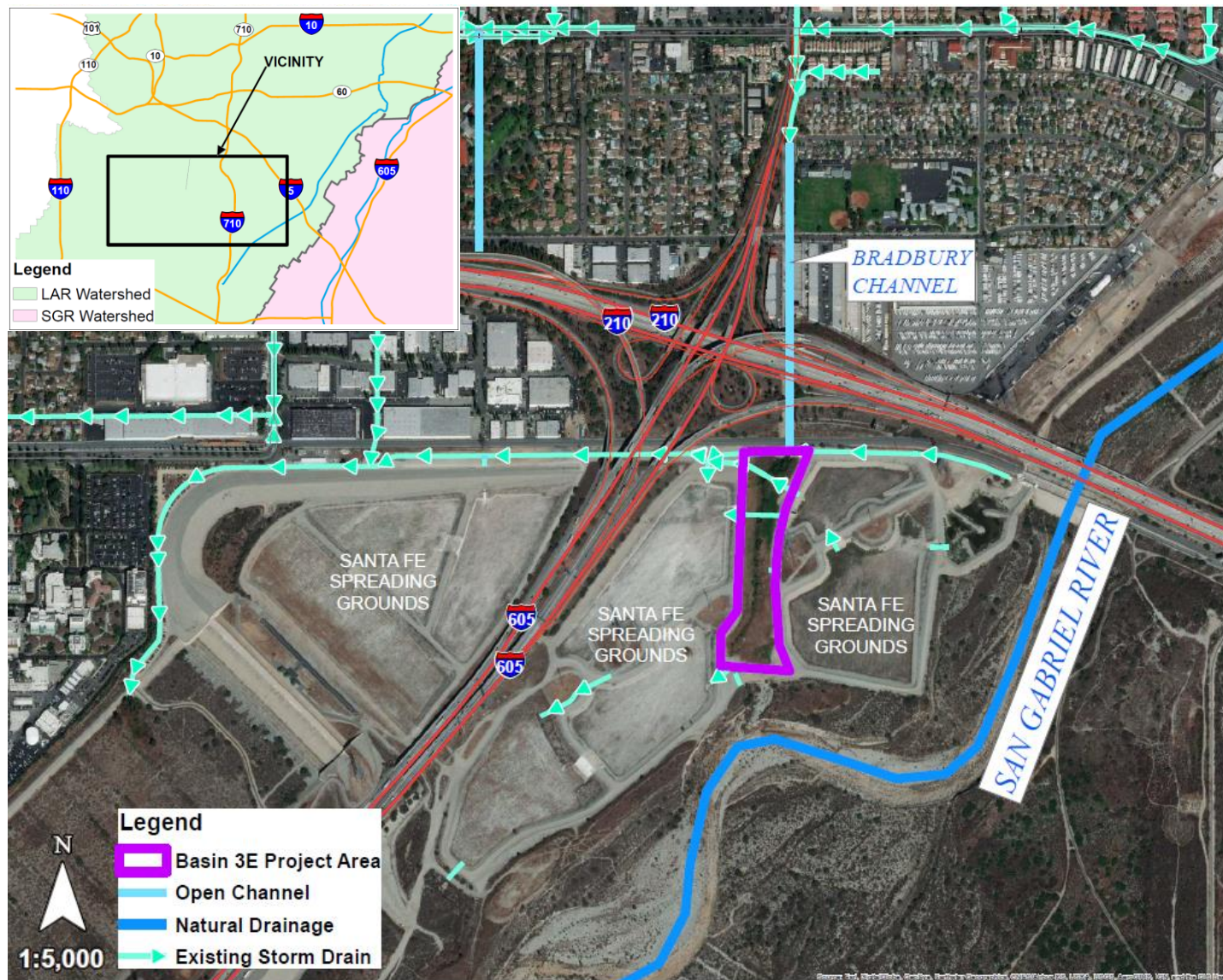


**PLAN VIEW**  
 (See Fact Sheet for Additional Details)

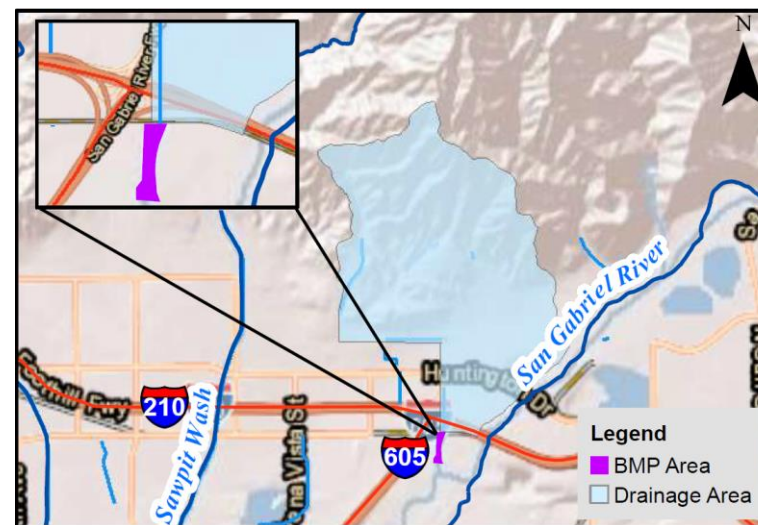


**EXHIBIT B.4.2 FACT SHEET**

**EXISTING SITE CONDITIONS**



**DRAINAGE AREA**



**DRAINAGE CHARACTERISTICS**

DRAINAGE AREA (acres)	2,137
HYDROLOGIC SOIL GROUP	B
APPROX. DEPTH TO GROUNDWATER (ft)	312
SOIL DESCRIPTION	Well-drained/ somewhat excessively drained
MODELED AVERAGE ANNUAL RUNOFF VOLUME (ac-ft)	793.52

**BMP CHARACTERISTICS**

LOCATION: CITY OF IRWINDALE	LAT: 34° 7'49.40"N LONG: 117°57'23.42"W
<b>Proposed BMP Description:</b> The proposed project would restore an existing detention basin at the outlet of Bradbury Channel by constructing a sand filter basin similar to the Austin Sand Filter by Caltrans and treating the water without negatively impacting the Santa Fe Spreading Grounds. The project would consist of a sedimentation chamber with a water quality riser to a filtration chamber that includes filter media, underdrain cleanouts, and overflow spillways to convey treated water either to the surrounding spreading grounds or to the spillway basins to the San Gabriel River. This sand filter basin will provide a natural treatment system for the recharge basins to infiltrate into the San Gabriel Groundwater Basin.	<b>Project Benefits:</b> <ul style="list-style-type: none"> <li>• Groundwater recharge</li> <li>• Aquatic Ecosystem Restoration with a natural treatment wetlands</li> <li>• Water Quality Improvement in the San Gabriel River</li> </ul>

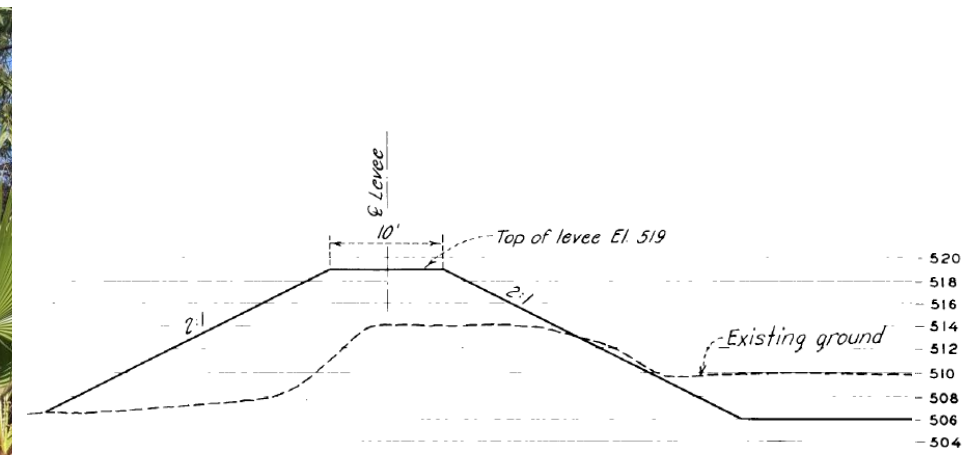
**Bradbury Channel Outlet to Existing Detention Basin**



**Basin 3E Outlet to the San Gabriel River**



**Existing Cross Section of Basin 3E**

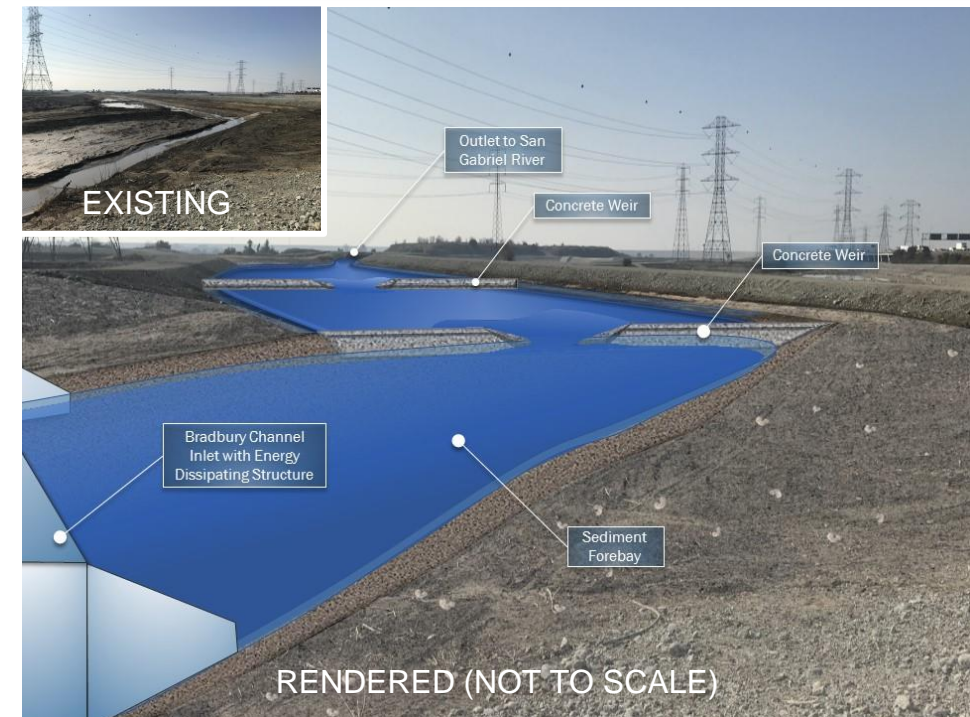


**PROPOSED CONCEPTUAL SITE LAYOUT**

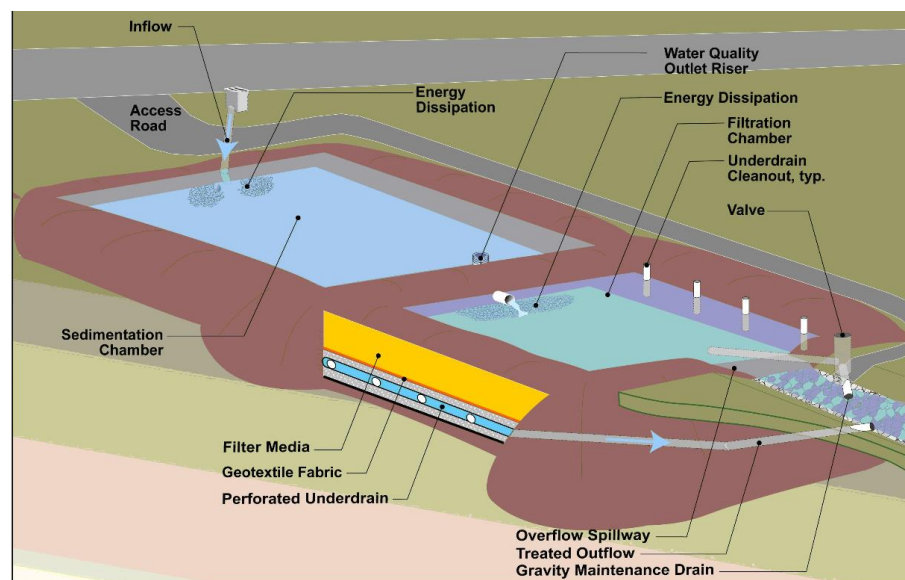


**PLANNING-LEVEL COST ESTIMATE**

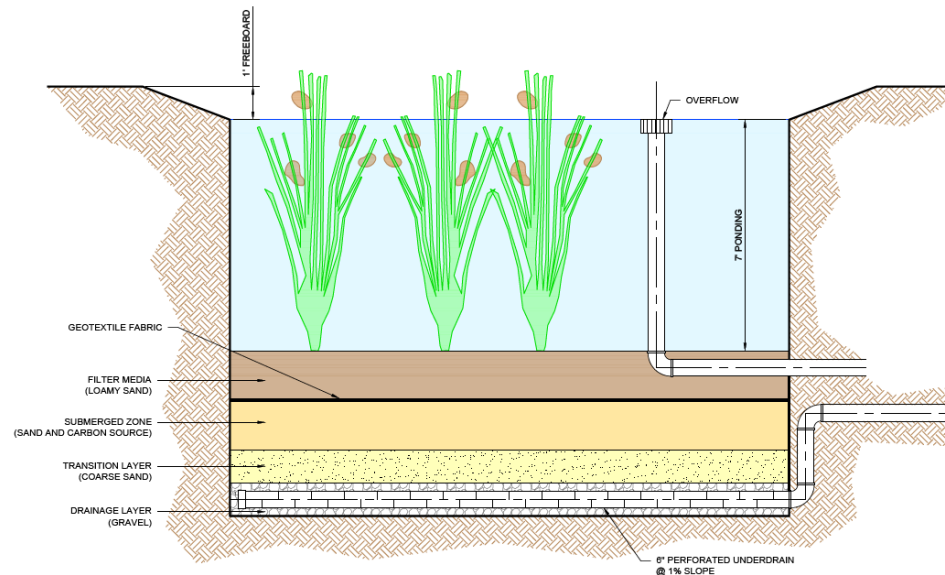
DESCRIPTION	TOTAL COST
Bradbury Channel, Pretreatment, and Conveyance	\$547,700
Storage and Treatment	\$1,051,314
<b>SUBTOTAL</b>	<b>\$1,599,014</b>
Mobilization/Demobilization (5% of Subtotal)	\$79,951
Estimating Contingency (25% of Subtotal)	\$399,754
<b>TOTAL COST</b>	<b>\$2,078,718</b>



**ISOMETRIC VIEW OF CALTRANS AUSTIN SAND FILTER BASIN**  
(Source: Caltrans DOT)



**TREATMENT SECTION**



**PROJECT CHARACTERISTICS**

Zinc Reduction Achieved (Note: this project is nested; % Zn reduction contingent upon downstream project)	64.3 lb/yr (7.5%)
Design Sand Depth Design Gravel Layer Depth	1.5' 1'
Estimated Storage Capacity for Basin	11.4 ac-ft
Estimate Annual Groundwater Recharge	337 ac-ft/yr

CITY OF BRADBURY, CITY OF DUARTE, AND THE COUNTY OF LOS ANGELES  
**BASIN 3E ENHANCEMENTS AT SANTA FE SPREADING GROUNDS PROJECT**



## **APPENDIX B.5 POTENTIAL GREEN STREET PROJECTS AND EXAMPLE CONFIGURATIONS AND DETAILS**

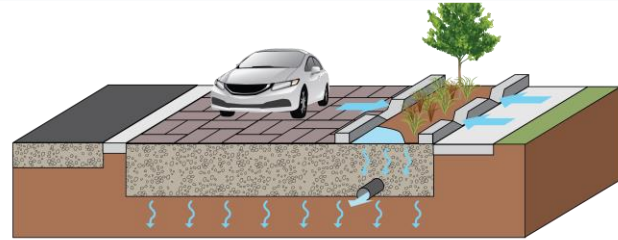
## Green Streets Role in rEWMP

Green streets and distributed stormwater control measures are required to meet the pollutant reduction targets of the rEWMP in areas not draining to a multi-benefit regional projects (specifically, in the Big Dalton Wash watershed and portions of the EWMP area that drain downstream from the Rio Hondo compliance point via Eaton Wash). The rEWMP green street strategy will be augmented during adaptive management.

Parameter	Big Dalton Wash	Eaton Wash
Assumed Drainage Area (acres)	674.7	326.6
Total Footprint (ac)	3.8	5.2
Total Length (miles) – Assuming 4' width	7.8	10.7
Achieved Load Reduction (lb/yr)	54.7 (3.7%)	59.5 (18.4%)
Cost, including 20 years O&M (million \$)	11.4	15.8

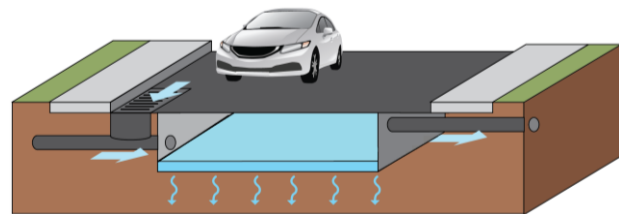
## Bio-(in)filtration

This is a soil and plant-based infiltration device that removes pollutants, through physical, biological, and chemical treatment processes. These facilities normally consist of a grass buffer strip, ponding area, mulch later, planting soil, and native vegetation. This unit can be lined (**biofiltration**) and stormwater is directed to an underdrain, or it can be open-bottom and stormwater can infiltrate (**bioinfiltration** – shown below). This type of green street device can be constructed within road islands to minimize the impact on surrounding infrastructure. **Porous Pavement** can also be incorporated into this BMP which consists of a rigid, load-bearing, durable surface with an underlying layered storage area. Stormwater is temporarily stored prior to infiltration. These BMPs are not mutually exclusive.



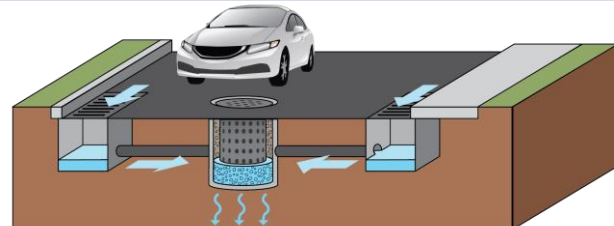
## Infiltration Gallery

This is a large open bottom unit that collects stormwater and allows for increased detention time as well as infiltration into the native soils. Infiltration galleries can be constructed anywhere within the street/median where utility conflicts can be avoided.

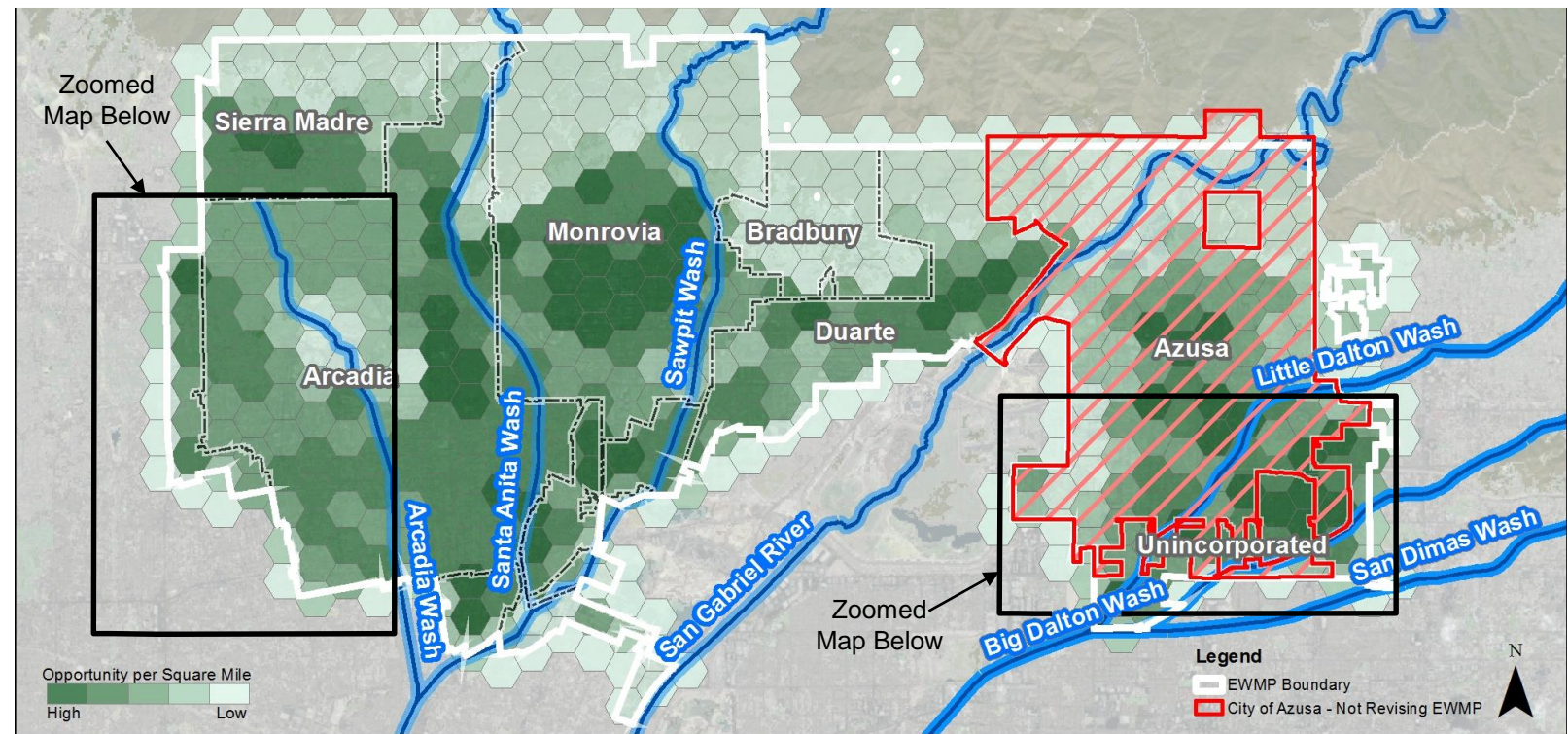


## Dry Well

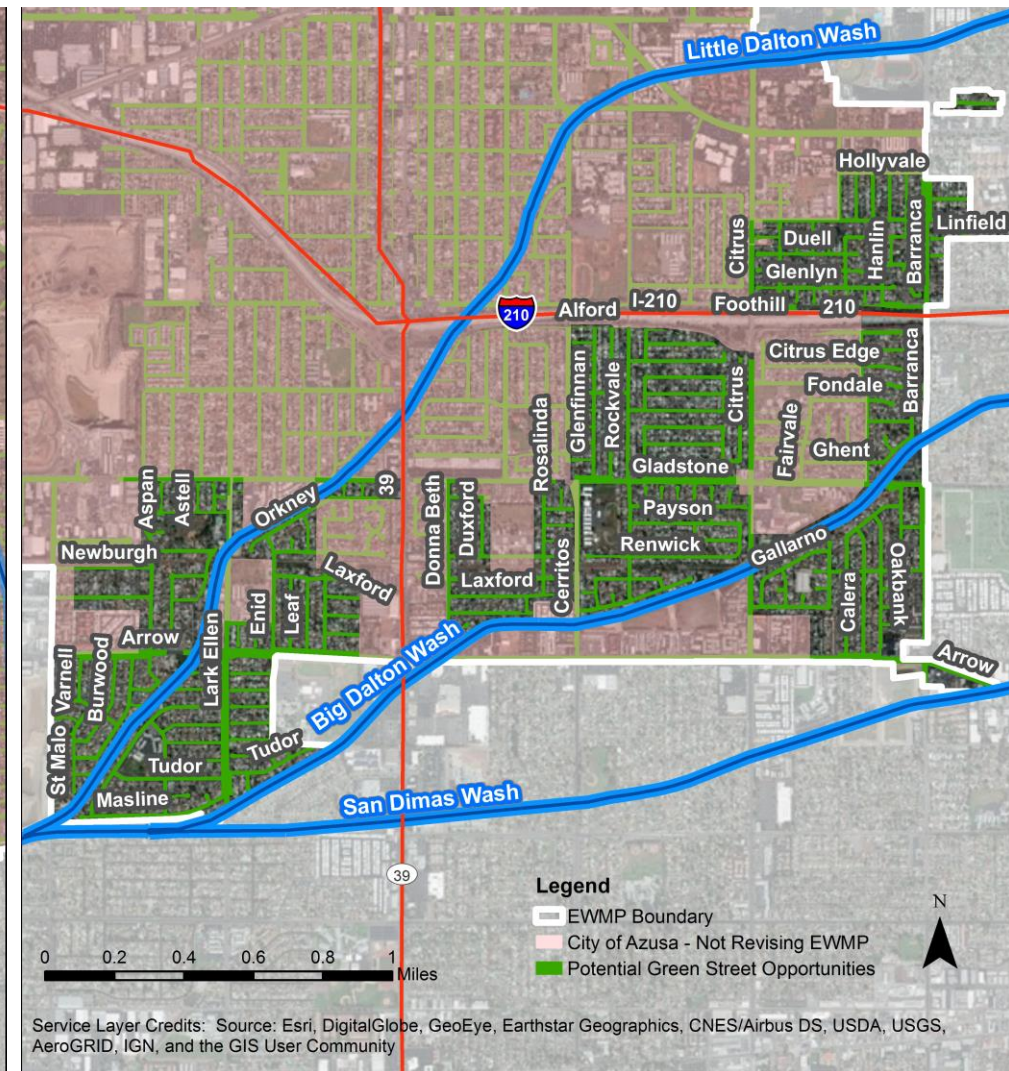
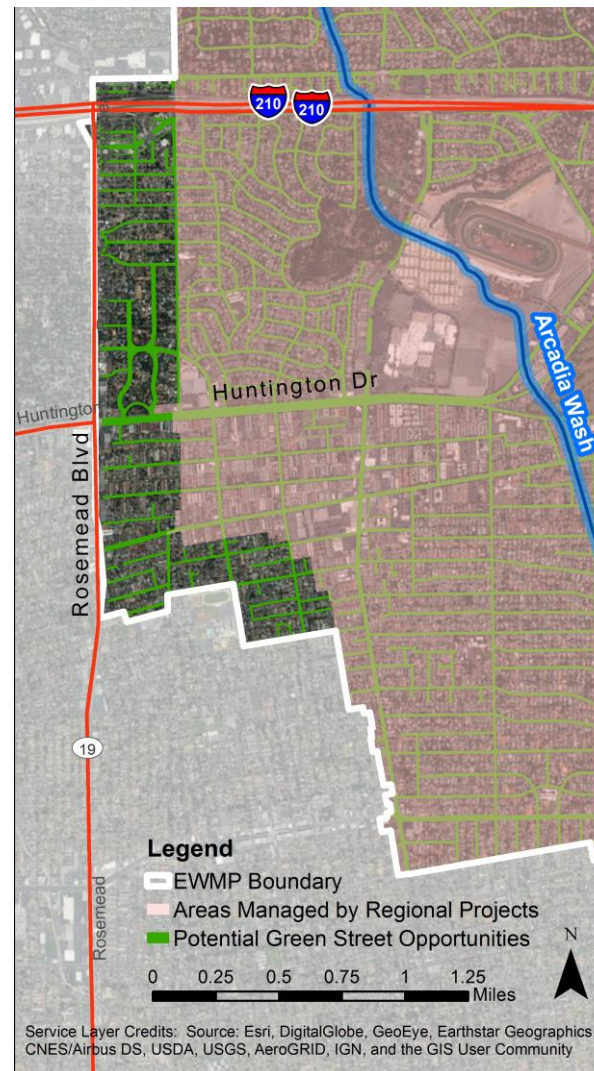
This is a perforated subsurface unit that intercepts runoff from storm drain inlets. Stormwater is then infiltrated to the underlying soil. Depending on the underlying soil conditions, the drywell may need to be constructed at a larger depth to obtain satisfactory infiltration rates. Drywells can be constructed within both the street or the median.



## Potential Green Street Opportunities



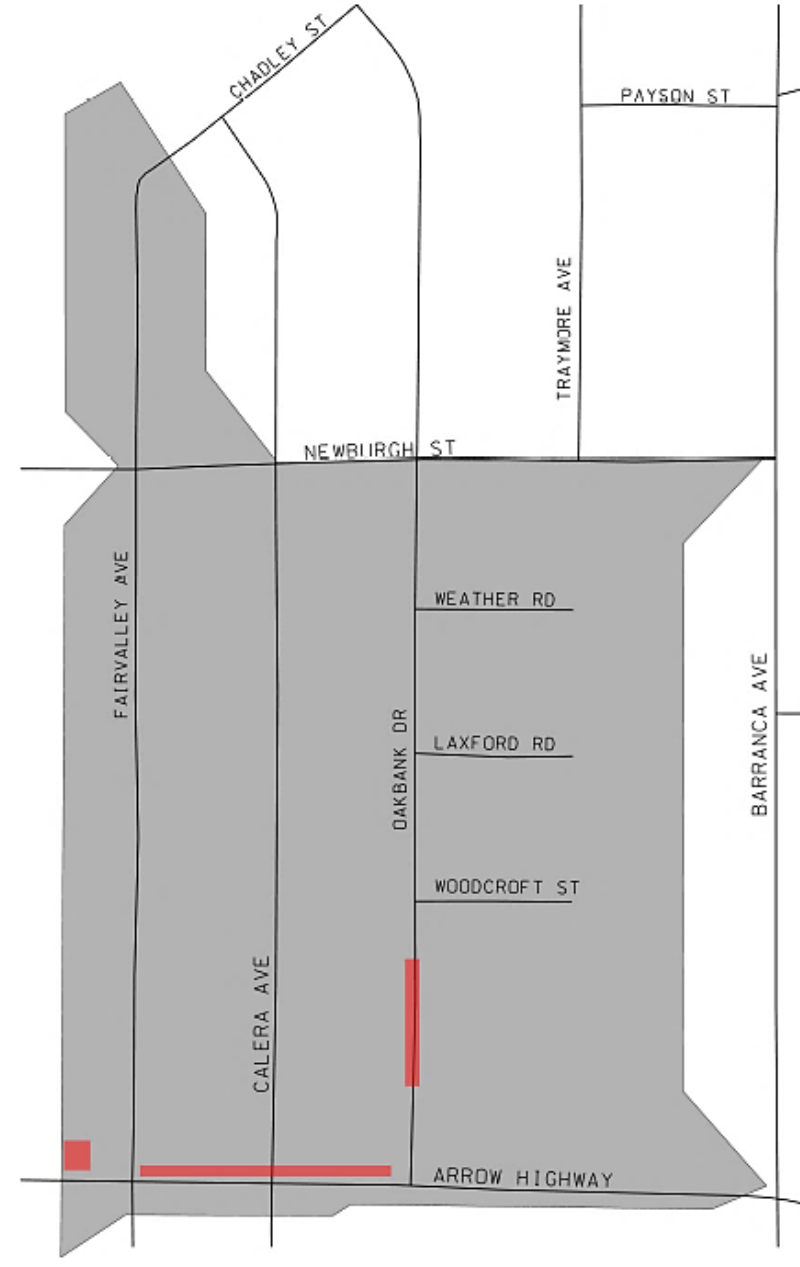
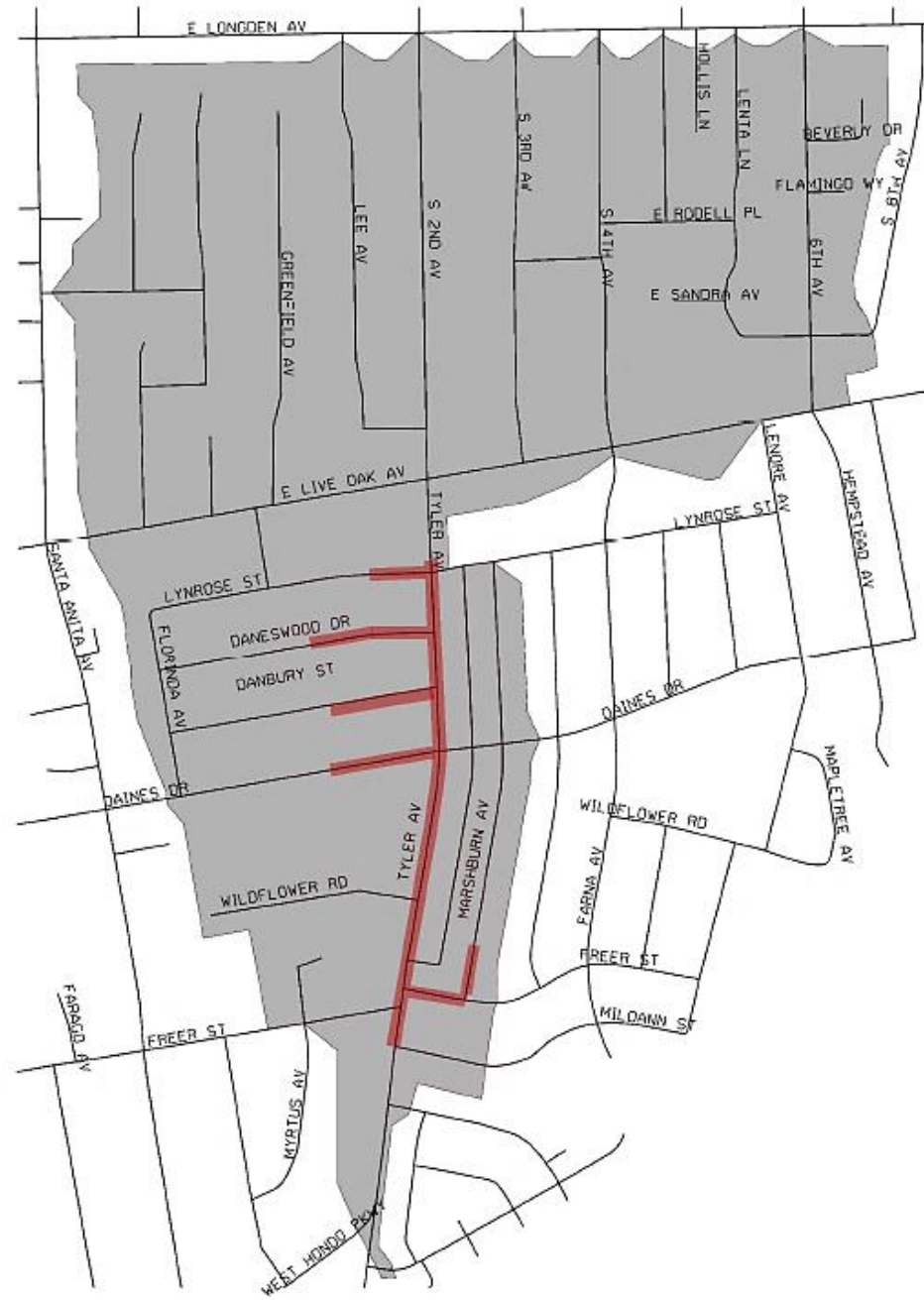
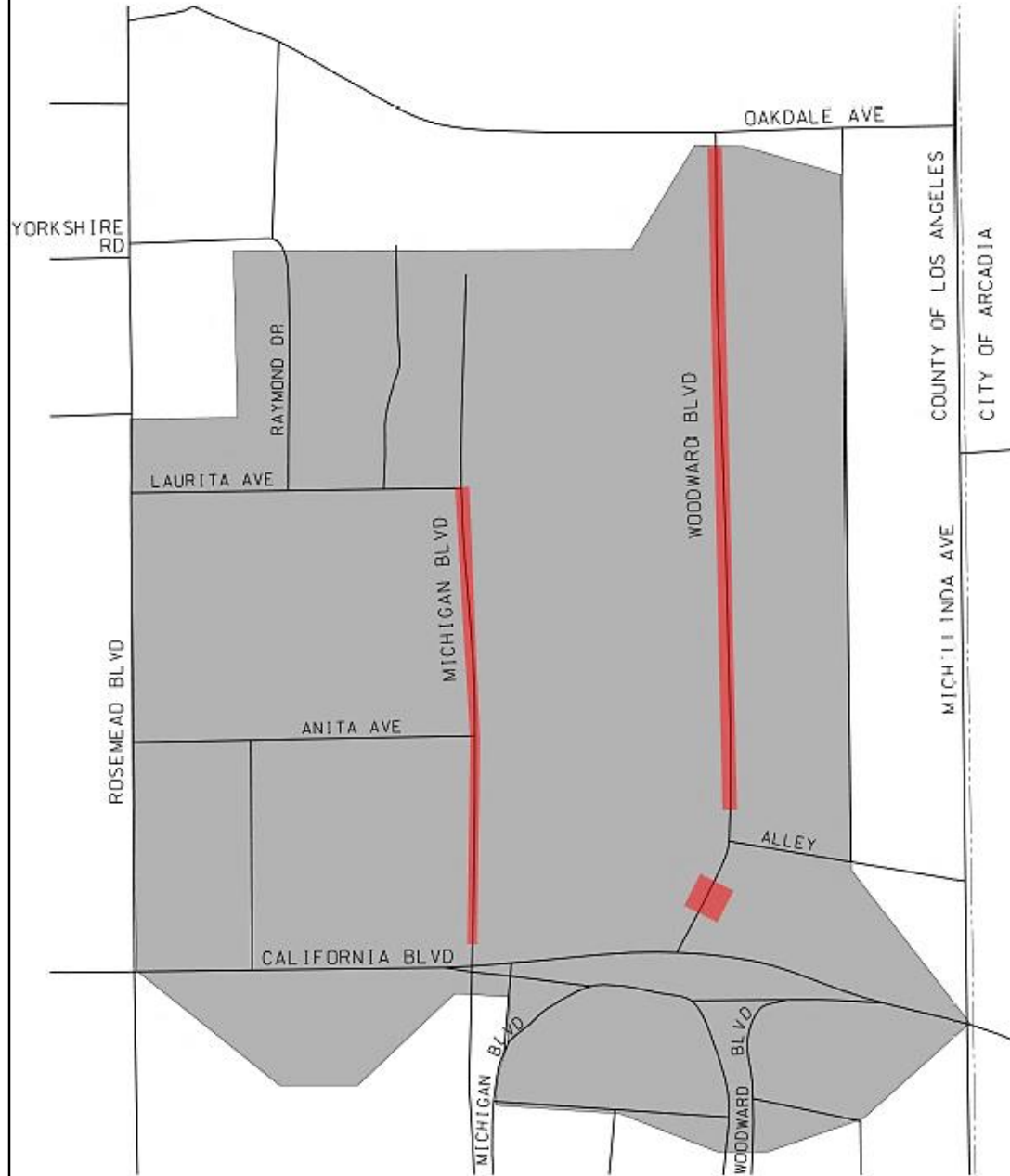
## Unincorporated County Areas Prioritized for Green Streets within the Big Dalton Wash and Eaton Wash Watersheds





**Selection Criteria**

- Prioritize green streets with “High” ranking in EWMP
- Not located in the drainage area of a regional project
- Close to a storm drain draining mainly County area and maximized drainage area
- Divert from a storm drain, not the receiving water body
- Green street located in a parkway, media, or residential street, or a combination.

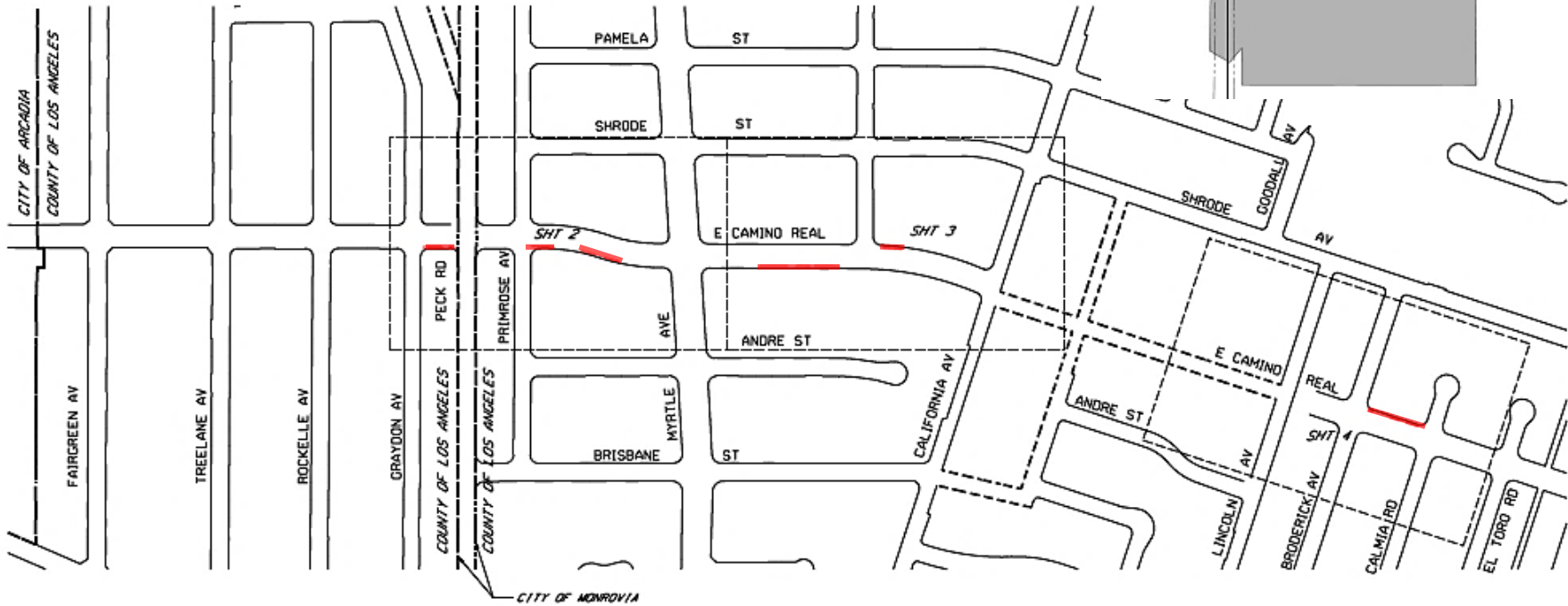


PLAN  
NO SCALE

**LEGEND**

- PROPOSED LID





LEGEND

■ PROPOSED LID

