

North Coast Regional Water Quality Control Board

**ORDER No. R1-2017-0005**  
**NPDES No. CA0022730**  
**WDID No. 1B83135OHUM**

**WASTE DISCHARGE REQUIREMENTS**

**FOR THE**

**CITY OF FORTUNA  
MUNICIPAL WASTEWATER TREATMENT PLANT  
HUMBOLDT COUNTY**

The following Permittee is subject to waste discharge requirements (WDRs) set forth in this Order:

**Table 1. Permittee Information**

<b>Permittee</b>	City of Fortuna
<b>Name of Facility</b>	Municipal Wastewater Treatment Plant
<b>Facility Address</b>	180 Dinsmore Drive
	Fortuna, CA 95540
	Humboldt County
<b>Type of Facility</b>	Publicly Owned Treatment Works (POTW)
<b>Facility Design Flow</b>	1.5 million gallons per day (mgd) (average dry weather treatment capacity) 7.0 mgd (peak wet weather flow capacity)

**Table 2. Discharge Locations**

<b>Discharge Point</b>	<b>Effluent Description</b>	<b>Discharge Point Latitude (North)</b>	<b>Discharge Point Longitude (West)</b>	<b>Receiving Water</b>
001	Treated municipal wastewater	40° 35' 21"	124° 09' 32"	Strongs Creek
003	Treated municipal wastewater	40° 35' 25"	124° 09' 42"	Percolation Ponds/ Eel River

**Table 3. Administrative Information**

This Order was adopted on:	<b>August 17, 2017</b>
This Order shall become effective on:	<b>November 1, 2017</b>
This Order shall expire on:	<b>October 30, 2022</b>
The Permittee shall file a Report of Waste Discharge as an application for reissuance of WDRs in accordance with title 23, California Code of Regulations, (CCR) and an application for reissuance of a National Pollutant Discharge Elimination System (NPDES) permit no later than:	<b>November 1, 2021</b>
The U.S. Environmental Protection Agency (U.S. EPA) and the California Regional Water Quality Control Board, North Coast Region have classified this discharge as follows:	Major

IT IS HEREBY ORDERED, that Waste Discharge Requirements (WDR) Order No. R1-2011-0004 and Monitoring and Reporting Program (MRP) No. R1-2011-0004, are rescinded upon the effective date of this Order except for enforcement purposes, and in order to meet the provisions contained in division 7 of the California Water Code (Water Code) (commencing with section 13000) and regulations and guidelines adopted thereunder, and the provisions of the federal Clean Water Act (CWA) and regulations and guidelines adopted thereunder, the Permittee shall comply with the requirements of this Order. This action in no way prevents the North Coast Regional Water Quality Control Board (Regional Water Board) from taking enforcement action for past violations of the previous permit.

I, Matthias St. John, Executive Officer, do hereby certify that this Order with all attachments is a full, true, and correct copy of the Order adopted by the California Regional Water Quality Control Board, North Coast Region, on **August 17, 2017**.

\_\_\_\_\_  
 Matthias St. John, Executive Officer

17\_0005\_Fortuna\_NPDES

**Contents**

I. Facility Information..... 4  
 II. Findings..... 4  
 III. Discharge Prohibitions ..... 4  
 IV. Effluent Limitations and Discharge Specifications..... 5  
     A. Effluent Limitations – Discharge Points 001 and 003 ..... 5  
     B. Land Discharge Specifications and Requirements– Not Applicable ..... 7  
     C. Water Recycling Specifications and Requirements – Not Applicable ..... 7  
     D. Other Requirements ..... 7  
 V. Receiving Water Limitations ..... 8  
     A. Surface Water Limitations ..... 8  
     B. Groundwater Limitations ..... 9  
 VI. Provisions..... 10  
     A. Standard Provisions..... 10  
     B. Monitoring and Reporting Program (MRP) Requirements..... 10  
     C. Special Provisions ..... 11  
 VII. Compliance Determination ..... 19

**Tables**

Table 1. Permittee Information ..... 1  
 Table 2. Discharge Locations ..... 1  
 Table 3. Administrative Information..... 2  
 Table 4. Final Effluent Limitations ..... 6  
 Table 5. Interim Effluent Limitations ..... 7  
 Table 6 Schedule for Compliance with Final Effluent Limitations for Total Ammonia and Nitrate ..... 18

**Attachments**

Attachment A – Definitions ..... A-1  
 Attachment B – Map ..... B-1  
 Attachment C – Flow Schematic ..... C-1  
 Attachment D – Standard Provisions ..... D-1  
 Attachment E – Monitoring and Reporting Program..... E-1  
 Attachment F – Fact Sheet ..... F-1

## I. FACILITY INFORMATION

Information describing the City of Fortuna (Permittee), Municipal Wastewater Treatment Plant (Facility) is summarized in Table 1 and in sections I and II of the Fact Sheet (Attachment F). Section I of the Fact Sheet also includes information regarding the Facility's permit application.

## II. FINDINGS

The California Regional Water Quality Control Board, North Coast Region (Regional Water Board), finds:

**Legal Authorities.** This Order is issued pursuant to section 402 of the federal Clean Water Act (CWA) and implementing regulations adopted by the U.S. Environmental Protection Agency (U.S. EPA) and chapter 5.5, division 7 of the California Water Code (commencing with section 13370). It shall serve as a NPDES permit authorizing the Permittee to discharge into waters of the United States at the discharge location described in Table 2 and subject to the Waste Discharge Requirements (WDRs) in this Order. This Order also serves as WDRs pursuant to article 4, chapter 4, division 7 of the Water Code (commencing with section 13260).

**Basis and Rationale for Requirements.** The Regional Water Board developed the requirements in this Order based on information submitted as part of the Permittee's application, monitoring and reporting programs, and other available information. The Fact Sheet (Attachment F) contains background information and rationale for the requirements in this Order, and is hereby incorporated into this Order and constitutes Findings for this Order. Attachments A through E are also incorporated into this Order.

**Provisions and Requirements Implementing State Law.** The provisions/requirements in subsections III.E, III.F, III.J, IV.B – IV.D, V.B, and VI.C.5.a, VI.C.5.d. and VI.C.5.e of this Order and sections VI, VII, VIII.C, IX.A and X.E of the Monitoring and Reporting Program are included to implement state law only. These provisions/requirements are not required or authorized under the federal CWA; consequently, violations of these provisions/requirements are not subject to the enforcement remedies that are available for NPDES violations.

**Notification of Interested Parties.** The Regional Water Board has notified the Permittee and interested agencies and persons of its intent to prescribe WDRs for the discharge and has provided them with an opportunity to submit their written comments and recommendations. Details of the notification are provided in the Fact Sheet.

**Consideration of Public Comment.** The Regional Water Board, in a public meeting, heard and considered all comments pertaining to the discharge. Details of the Public Hearing are provided in the Fact Sheet.

## III. DISCHARGE PROHIBITIONS

- A. The discharge of any waste not disclosed by the Permittee or not within the reasonable contemplation of the Regional Water Board is prohibited.
- B. Creation of pollution, contamination, or nuisance, as defined by section 13050 of the Water Code is prohibited.
- C. The discharge of sludge or digester supernatant is prohibited, except as authorized under section VI.C.5.c of this Order (Sludge Disposal and Handling Requirements).
- D. The discharge of untreated or partially treated waste (receiving a lower level of treatment than described in section II.A of the Fact Sheet) from anywhere within the collection, treatment, or disposal systems is prohibited, except as provided for in Attachment D, Standard Provisions G (Bypass) and H (Upset).

- E. Any sanitary sewer overflow (SSO) that results in a discharge of untreated or partially treated wastewater to (a) waters of the state or (b) land and creates pollution, contamination, or nuisance, as defined in Water Code section 13050(m) is prohibited.
- F. The discharge of waste to land that is not owned by the Permittee, governed by City ordinance, or under agreement to use by the Permittee, or for which the Permittee has explicitly permitted such use, is prohibited, except for use for fire suppression as provided in title 22, sections 60307(a) and 60307(b) of the California Code of Regulations (CCR).
- G. The discharge of waste at any point not described in Finding II.B of the Fact Sheet or authorized by a permit issued by the State Water Resources Control Board (State Water Board) or another Regional Water Board is prohibited.
- H. The average dry weather flow of waste through the Facility shall not exceed 1.5 mgd, measured daily and averaged over a calendar month. The peak daily wet weather flow of waste through the Facility shall not exceed 7.0 mgd, measured daily. Compliance with this prohibition shall be determined as defined in sections VII.K and VII.L of this Order.
- I. The discharge of waste to the Eel River and its tributaries is prohibited during the period from May 15 through September 30 of each year.
- J. During the period from October 1 through May 14 of each year, discharges of treated wastewater to Strongs Creek, a tributary to the Eel River, shall not exceed one percent of the flow of the Eel River as measured by the sum of the flows at the United States Geological Survey (USGS) Station in the Eel River near Scotia and at USGS Station 11478500 in the Van Duzen River near Bridgeville. For the purposes of this Order, compliance with this discharge prohibition shall be determined as follows:
- K. The discharge of secondary treated wastewater shall be adjusted at least once daily to avoid exceeding, to the extent practicable, one percent of the most recent daily flow measurement of the Eel River daily flow shall be based on flow meter comparisons reasonably read between the hours of 12:01 am and 12:00 midnight; and,
- L. In no case shall the total volume of secondary treated wastewater discharged in a calendar month exceed one percent of the total volume of the Eel River in the same calendar month. At the beginning of the discharge season, the monthly flow volume comparisons shall be based on the date when the discharge commenced to the end of the calendar month. At the end of the discharge season, the monthly flow volume shall be based on the first day of the calendar month to the date when the discharge ceased for the season
- M. The discharge of any radiological, chemical, or biological warfare agent into waters of the state is prohibited under Water Code section 13375.
- N. The acceptance of septage to a location other than an approved septage receiving station is prohibited.

#### **IV. EFFLUENT LIMITATIONS AND DISCHARGE SPECIFICATIONS**

##### **A. Effluent Limitations – Discharge Points 001 and 003**

##### **1. Final Effluent Limitations – Discharge Points 001 and 003**

- a. The discharge of treated wastewater shall maintain compliance with the following effluent limitations at Discharge Points 001 and 003, with compliance measured at

Monitoring Locations EFF-001 and EFF-003 as described in the Monitoring and Reporting Program (MRP) (Attachment E).

**Table 4. Final Effluent Limitations**

Parameter	Units	Effluent Limitations <sup>1</sup>				
		Average Monthly	Average Weekly	Maximum Daily	Instantaneous Minimum	Instantaneous Maximum
Biochemical Oxygen Demand 5-day @ 20°C (BOD <sub>5</sub> )	mg/L	30	45	--	--	--
Total Suspended Solids (TSS)	mg/L	30	45	--	--	--
pH	s.u.	--	--	--	6.5	8.5
Chlorine, Total Residual <sup>2</sup>	mg/L	0.01	--	0.02	--	--
Settleable Solids	ml/L	0.1	--	0.2	--	--
Dichlorobromomethane	µg/L	0.56	--	1.1	--	--
Heptachlor Epoxide	µg/L	0.00010	--	0.00020	--	--
Ammonia Nitrogen, Total (as N)	mg/L	3.6	--	9.6	--	--
Nitrate Nitrogen, Total (as N)	mg/L	10	--	--	--	--

Table Notes:  
 1. See Definitions in Attachment A and Compliance Determination discussion in section VII of this Order.  
 2. See section VII.M of this Order regarding compliance with chlorine residual effluent limitations.

- b. Percent Removal.** The average monthly percent removal of BOD<sub>5</sub> and TSS shall not be less than 85 percent. Percent removal shall be determined from the monthly average value of influent wastewater concentration in comparison to the monthly average value of effluent concentration for the same constituent over the same time period as measured at Monitoring Locations INF-001 and EFF-001 or EFF-003, respectively.
- c. Disinfection.** Disinfected effluent discharged from the Facility through Discharge Point 001 to Strongs Creek and through Discharge Point 003 to the Eel River shall not contain total coliform bacteria exceeding the following concentrations, as measured at Monitoring Locations EFF-001 and EFF-003:
  - i.** The median concentration shall not exceed a Most Probable Number (MPN) of 23 per 100 milliliters (mL) in a calendar month; and
  - ii.** No sample shall exceed an MPN of 240 total coliform bacteria per 100 mL.
- d. Acute Toxicity.** There shall be no acute toxicity in treated wastewater discharged to Strongs Creek/Eel River, as measured at Monitoring Locations EFF-001 and EFF-003. The Permittee will be considered in compliance with this limitation when the survival of aquatic organisms in a 96-hour bioassay of undiluted effluent complies with the following:
  - i.** Minimum for any one bioassay: 70 percent survival; and
  - ii.** Median for any three or more consecutive bioassays: at least 90 percent survival.

Compliance with these effluent limitations shall be determined in accordance with section VII.I of this Order and section V.A of the MRP (Attachment E).

- e. **Chronic Toxicity, TST:** As measured at Monitoring Locations EFF-001 and EFF-003, there shall be no chronic toxicity in the effluent when discharging to Strongs Creek or the Eel River. Compliance with this effluent limitation shall be determined in accordance with section VII.J of this Order and sections V.B and V.C of the MRP (Attachment E).

**2. Interim Effluent Limitations – Discharge Points 001 and 003**

Until the activation of the upgraded Facility or December 31, 2024, whichever comes first, the Permittee shall maintain compliance with the following interim effluent limitation at Discharge Points 001 and 003, with compliance measured at Monitoring Locations Eff-001 and EFF-003, as described in the attached MRP.

**Table 5. Interim Effluent Limitations**

Parameter	Units	Average Monthly
Ammonia Nitrogen, Total (as N)	mg/L	9.4
Nitrate Nitrogen, Total (as N)	mg/L	32

**B. Land Discharge Specifications and Requirements– Not Applicable**

This Order does not authorize discharges to land.

**C. Water Recycling Specifications and Requirements – Not Applicable**

This Order does not authorize discharges of recycled water.

**D. Other Requirements**

1. **Total Residual Chlorine, Monitoring Location INT-001.** As measured at the end of the chlorine contact chamber at Monitoring Location INT-001, the total residual chlorine concentration shall be maintained at a level that ensures the discharge meets the total coliform effluent limitation at the end of the disinfection process for discharges to Discharge Points 001 and 003. By **May 1, 2019**, the Permittee shall provide continuous chlorine residual monitoring to demonstrate that the appropriate chlorine residual concentration is maintained in the effluent at INT-001 at all times and submit a written report confirming compliance with this requirement.
2. **Total Residual Chlorine, Monitoring Location EFF-001 and EFF-003.** By **May 1, 2019**, the Permittee shall provide continuous monitoring to demonstrate that the discharge has been adequately dechlorinated to achieve chlorine residual effluent limitations specified in section IV.A.1.a, Table 4, at all times and submit a written report confirming compliance with this requirement.
3. **Total Residual Chlorine Analyzer Calibration.** The Permittee shall calibrate chlorine residual analyzers against grab samples as frequently as necessary to maintain accurate and reliable operation.

## **V. RECEIVING WATER LIMITATIONS**

### **A. Surface Water Limitations**

Receiving water limitations are based on water quality objectives contained in the Basin Plan, and are a required part of this Order. Receiving water conditions not in conformance with the limitation are not necessarily a violation of this Order. Compliance with receiving water limitations shall be measured at monitoring locations described in the MRP (Attachment E). The Regional Water Board may require an investigation to determine cause and culpability prior to asserting that a violation has occurred.

1. The discharge shall not cause the dissolved oxygen concentration of the receiving water to be depressed below 7.0 mg/L. Additionally, the discharge shall not cause the dissolved oxygen content of the receiving water to fall below 10.0 mg/L more than 50 percent of the time, or below 7.5 mg/L more than 10 percent of the time in a calendar year. In the event that the receiving waters are determined to have a dissolved oxygen concentration of less than 7.0 mg/L, the discharge shall not depress the dissolved oxygen concentration below the existing level.
2. The discharge shall not cause the pH of receiving waters to be depressed below 6.5 nor raised above 8.5. Within this range, the discharge shall not cause the pH of the receiving waters to be changed at any time more than 0.5 units from that which occurs naturally.
3. The discharge shall not cause the specific conductance (micromhos<sup>1</sup>) concentration of the receiving waters to increase above 225 micromhos more than 50 percent of the time, or above 375 micromhos more than 10 percent of the time.
4. The discharge shall not cause the total dissolved solids concentration of the receiving waters to increase above 140 mg/L more than 50 percent of the time, or above 275 mg/L more than 10 percent of the time.
5. The discharge shall not cause the turbidity of receiving waters to be increased more than 20 percent above naturally occurring background levels.
6. The discharge shall not cause receiving waters to contain suspended material in concentrations that cause nuisance or adversely affect beneficial uses.
7. The discharge shall not cause receiving waters to contain floating materials, including solids, liquids, foams, and scum, in concentrations that cause nuisance or adversely affect beneficial uses.
8. The discharge shall not cause receiving waters to contain taste- or odor-producing substances in concentrations that impart undesirable tastes or odors to fish flesh or other edible products of aquatic origin, that cause nuisance, or that adversely affect beneficial uses.
9. The discharge shall not cause coloration of receiving waters that causes nuisance or adversely affects beneficial uses.

---

<sup>1</sup> Measured at 77°F.



10. The discharge shall contain substances in concentrations that result in deposition of material in receiving waters to the extent that such deposits cause nuisance or adversely affect beneficial uses.
11. The discharge shall not cause receiving waters to contain concentrations of biostimulatory substances that promote objectionable aquatic growth to the extent that such growth causes nuisance or adversely affects beneficial uses.
12. The discharge shall not cause receiving waters to contain toxic substances in concentrations that are toxic to, or that produce detrimental physiological responses in humans, plants, animals, or aquatic life. Compliance with this objective will be determined by use of indicator organisms, analyses of species diversity, population density, growth anomalies, bioassays of appropriate duration, or other appropriate methods, as specified by the Regional Water Board.
13. The discharge shall not cause a measurable temperature change in the receiving water at any time.
14. The discharge shall not cause an individual pesticide or combination of pesticides to be present in concentrations that adversely affect beneficial uses. The discharge shall not cause bioaccumulation of pesticide concentrations in bottom sediments or aquatic life.
15. The discharge shall not cause receiving waters to contain concentrations of pesticides in excess of Maximum Contaminant Levels (MCLs) established for these pollutants in title 22, division 4, chapter 15, articles 4 and 5.5 of the CCR.
16. The discharge shall not cause receiving waters to contain oils, greases, waxes, or other materials in concentrations that result in a visible film or coating on the surface of the water or on objects in the water, that cause nuisance, or that otherwise affect beneficial uses.
17. The discharge shall not cause a violation of any applicable water quality standard for receiving waters adopted by the Regional Water Board or the State Water Board, as required by the federal Clean Water Act and regulations adopted thereunder. If more stringent applicable water quality standards are promulgated or approved pursuant to section 303 of the Clean Water Act, or amendments thereto, the Regional Water Board will revise and modify this Order in accordance with such more stringent standards.
18. The discharge shall not cause concentrations of chemical constituents to occur in excess of MCLs established for these pollutants in title 22, division 4, chapter 15, articles 4 and 5.5 of the CCR.
19. The discharge shall not cause receiving waters to contain radionuclides in concentrations which are deleterious to human, plant, animal or aquatic life, nor which result in the accumulation of radionuclides in the food web to an extent which presents a hazard to human, plant, animal or indigenous aquatic life.

**B. Groundwater Limitations**

1. The collection, treatment, storage, and disposal of wastewater shall not cause a statistically significant degradation of groundwater quality unless a technical evaluation is performed that demonstrates that any degradation that could reasonably be expected to occur, after implementation of all regulatory requirements (e.g., Basin Plan) and reasonable best

management practices (BMPs), will not violate groundwater quality objectives or cause impacts to beneficial uses of groundwater.

2. The collection, treatment, storage, and disposal of wastewater shall not cause alterations of groundwater that result in chemical concentrations in excess of limits specified in title 22, division 4, chapter 15, article 4, sections 64431 (Tables 2 and 3) and 64444, and the Basin Plan.
3. The collection, treatment, storage, and disposal of wastewater shall not cause levels of radionuclides in groundwater in excess of the limits specified in title 22, division 4, chapter 15, article 5, section 64443 of the CCR.
4. The collection, treatment, storage, and disposal of wastewater shall not cause groundwater to contain taste - or odor-producing substances in concentrations that cause nuisance or adversely affect beneficial uses.
5. In groundwaters used for domestic or municipal supply (MUN), the collection, treatment, storage, and disposal of wastewater shall not cause the median of the most probable number of coliform organisms over any 7-day period to exceed 1.1 MPN/100 mL or 1 colony/100 mL.

## VI. PROVISIONS

### A. Standard Provisions

1. **Federal Standard Provisions.** The Permittee shall comply with all Standard Provisions included in Attachment D of this Order.
2. **Regional Water Board Standard Provisions.** The Permittee shall comply with the following Regional Water Board standard provisions. In the event that there is any conflict, duplication, or overlap between provisions specified by this Order, the more stringent provision shall apply:
  - a. Failure to comply with provisions or requirements of this Order, or violation of other applicable laws or regulations governing discharges from this facility, may subject the Permittee to administrative or civil liabilities, criminal penalties, and/or other enforcement remedies to ensure compliance. Additionally, certain violations may subject the Permittee to civil or criminal enforcement from appropriate local, state, or federal law enforcement entities.
  - b. In the event the Permittee does not comply or will be unable to comply for any reason, with any prohibition, final effluent limitation, other specification, receiving water limitation, or provision of this Order that may result in a significant threat to human health or the environment, such as inundation of treatment components, breach of pond containment, or unauthorized release, etc., that results in a discharge to a drainage channel or a surface water, the Permittee shall notify Regional Water Board staff within 24 hours of having knowledge of such non-compliance. Spill notification and reporting shall be conducted in accordance with Section V.E of Attachment D and X.E of the Monitoring and Reporting Program.

### B. Monitoring and Reporting Program (MRP) Requirements

The Permittee shall comply with the MRP, included as Attachment E of this Order, and future revisions thereto.

## C. Special Provisions

### 1. Reopener Provisions

- a. **Standard Revisions.** If applicable water quality standards are promulgated or approved pursuant to Section 303 of the CWA, or amendments thereto, the Regional Water Board may reopen this Order and make modifications in accordance with such revised standards.
- b. **Reasonable Potential.** This Order may be reopened for modification to include an effluent limitation, if monitoring establishes that the discharge causes, or has the reasonable potential to cause or contribute to, an excursion above a water quality criterion or objective applicable to the receiving water.
- c. **Whole Effluent Toxicity.** As a result of a Toxicity Reduction Evaluation (TRE), this Order may be reopened to include a numeric chronic toxicity limitation, a new acute toxicity limitation, and/or a limitation for a specific toxicant identified in the TRE. Additionally, if a numeric chronic toxicity water quality objective is adopted by the State Water Board, this Order may be reopened to include a numeric chronic toxicity effluent limitation based on that objective.
- d. **303(d)-Listed Pollutants.** If an applicable total maximum daily load (TMDL) (see Fact Sheet, section III.D) program is adopted, this Order may be reopened and effluent limitations for the pollutant(s) that are the subject of the TMDL may be modified or imposed to conform this Order to the TMDL requirements.
- e. **Water Effects Ratios (WERs) and Metal Translators.** A default WER of 1.0 has been used in this Order for calculating CTR criteria for applicable priority pollutant inorganic constituents except for copper, for which a site specific WER of 4.63 for total recoverable copper and 3.9 for dissolved copper has been used as further described in section IV.C.3.c of Attachment F. In addition, default dissolved-to-total metal translators have been used to convert water quality objectives from dissolved to total recoverable. If the Permittee performs studies to determine site-specific WERs and/or site-specific dissolved-to-total metal translators and submits a report that demonstrates that WER or translator studies were performed in accordance with U.S. EPA or other approved guidance, this Order may be reopened to modify the effluent limitations for the applicable constituents.
- f. **Nutrients.** This Order contains effluent limitations for ammonia and nitrate and effluent monitoring for nutrients (ammonia, nitrate, and phosphorus). If new water quality objectives for nutrients are established, if monitoring data indicate the need for new or revised effluent limitations for any of these parameters, or if new or revised methods for compliance with effluent limitations for any of these parameters are developed, this Order may be reopened and modified to include new or modified effluent limitations or other requirements, as necessary.

### 2. Special Studies, Technical Reports and Additional Monitoring Requirements

- a. **Ammonia Study.** The Permittee shall conduct a study to determine the presence of freshwater mussels in the receiving water to support implementation of the water quality criteria for ammonia in the April 2013 *Aquatic Life Ambient Water Quality for Ammonia – Freshwater 2013* (EPA-822-R-13-001). The Permittee may conduct

literature searches of historical mussel surveys and/or conduct a site-specific mussel survey to evaluate the presence/absence of mussels in the receiving water. The study shall be conducted in accordance with the August 2013 *Technical Support Document for Conducting and Reviewing Freshwater Mussel Occurrence Surveys for the Development of Site-Specific Water quality Criteria for Ammonia* (EPA-800-R-13-003). The Permittee shall submit a work plan for conducting the study by **November 1, 2019**. The study shall be initiated within 3 years of the permit effective date and a final report summarizing the results of the study shall be submitted by the Regional Water Board in conjunction with the Report of Waste Discharge by **August 1, 2021**.

### **3. Best Management Practices and Pollution Prevention**

#### **a. Pollutant Minimization Program (PMP)**

- i.** The Permittee shall, as required by the Executive Officer, develop and conduct a PMP as further described below when there is evidence (e.g., sample results from analytical methods more sensitive than those methods required by this Order, presence of whole effluent toxicity, health advisories for fish consumption, results of benthic or aquatic organism tissue sampling) that a priority pollutant is present in the effluent above an effluent limitation and either:
  - (a)** The concentration of the pollutant is reported as “Detected, but Not Quantified” (DNQ) and the effluent limitation is less than the reporting limit (RL);
  - (b)** A sample result is reported as non-detect (ND) and the effluent limitation is less than the method detection limit (MDL), using definitions described in Attachment A and reporting protocols described in MRP section X.B.5.
- ii.** The PMP shall include, but not be limited to, the following actions and submittals acceptable to the Regional Water Board:
  - (a)** An annual review and semi-annual monitoring of potential sources of the reportable priority pollutant(s), which may include fish tissue monitoring and other bio-uptake sampling;
  - (b)** Quarterly monitoring for the reportable priority pollutant(s) in the influent to the wastewater treatment system;
  - (c)** Submittal of a control strategy designed to proceed toward the goal of maintaining concentrations of the reportable priority pollutant(s) in the effluent at or below the effluent limitation;
  - (d)** Implementation of appropriate cost-effective control measures for the reportable priority pollutant(s), consistent with the control strategy; and
  - (e)** An annual status report that shall be submitted as part of the Annual Facility Report due **March 1st** to the Regional Water Board and shall include:
    - (1)** All PMP monitoring results for the previous year;
    - (2)** A list of potential sources of the reportable pollutant(s);
    - (3)** A summary of all actions undertaken pursuant to the control strategy; and

(4) A description of actions to be taken in the following year.

**4. Construction, Operation and Maintenance Specifications**

- a. This Order (Attachment D, Standard Provision I.D) requires that the Permittee at all times properly operate and maintain all facilities and systems of treatment and control (and related appurtenances) that are installed or used by the Permittee to achieve compliance with this Order. Proper operation and maintenance includes adequate laboratory quality control and appropriate quality assurance procedures.
- b. The Permittee shall maintain an updated Operation and Maintenance (O&M) Manual for the operational components of the Facility. The Permittee shall update the O&M Manual, as necessary, to conform to changes in operation and maintenance of the Facility. The Permittee shall operate and maintain the Facility in accordance with the most recently updated O&M Manual. The O&M Manual shall be readily available to operating personnel onsite and for review by state or federal inspectors. The O&M Manual shall include the following.
  - i. Description of the Facility's organizational structure showing the number of employees, duties and qualifications and plant attendance schedules (daily, weekends and holidays, part-time, etc.). The description should include documentation that the personnel are knowledgeable and qualified to operate the Facility so as to achieve the required level of treatment at all times.
  - ii. Detailed description of safe and effective operation and maintenance of treatment processes, process control instrumentation and equipment.
  - iii. Description of laboratory and quality assurance procedures.
  - iv. Process and equipment inspection and maintenance schedules.
  - v. Description of safeguards to assure that, should there be reduction, loss, or failure of electric power, the Permittee will be able to comply with requirements of this Order.
  - vi. Description of preventive (fail-safe) and contingency (response and cleanup) plans for controlling accidental discharges, and for minimizing the effect of such events. These plans shall identify the possible sources (such as loading and storage areas, power outage, waste treatment unit failure, process equipment failure, tank and piping failure) of accidental discharges, untreated or partially treated waste bypass, and polluted drainage.

**5. Special Provisions for Municipal Facilities (POTWs Only)**

**a. Wastewater Collection Systems**

**i. Statewide General WDRs for Sanitary Sewer Systems**

The Permittee has coverage under, and is separately subject to, the requirements of State Water Board Order No. 2006-0003-DWQ, Statewide General WDRs for Sanitary Sewer Systems, as amended by Order No. WQ 2013-0058-EXEC. As such, the Permittee provides notification and reporting of SSOs in accordance with the requirements of Order Nos. 2006-0003-DWQ and WQ 2013-0058-EXEC and any revisions thereto for operation of its wastewater collection system.

**b. Source Control and Pretreatment Provisions**

- i.** The Permittee shall perform source control functions and provide a summary of source control activities conducted in the Annual Report (due **March 1st** to the Regional Water Board). Source control functions and requirements shall include the following:
  - (a)** Implement the necessary legal authorities to monitor and enforce source control standards, restrict discharges of toxic materials to the collection system and inspect facilities connected to the system.
  - (b)** If waste haulers are allowed to discharge to the Facility, establish a waste hauler permit system, to be reviewed by the Executive Officer, to regulate waste haulers discharging to the collection system or Facility.
  - (c)** Perform public outreach to educate industrial, commercial, and residential users about the importance of preventing discharges of industrial and toxic wastes to the wastewater treatment plant, at least once per year.
  - (d)** Perform on-going inspections and monitoring, as necessary, to ensure adequate source control.
  - (e)** General Prohibitions. Pollutants introduced into WWTFs by a non-domestic source shall not pass through [40 CFR 403.3(n)] the WWTF or interfere [40 CFR 403.3(i)] with the operation or performance of the works. These general prohibitions and the specific prohibitions in paragraph (g) of this provision apply to all non-domestic sources introducing pollutants into a WWTF whether or not the source is subject to other National Pretreatment Standards or any national, state, or local pretreatment requirements.
  - (f)** Specific Prohibitions. In addition, the following pollutants shall not be introduced into a WWTF:
    - (1)** Pollutants that create a fire or explosion hazard in the WWTF;
    - (2)** Pollutants that will cause corrosive structural damage to the WWTF, but in no case discharges with pH lower than 5.0, unless the WWTF is specifically designed to accommodate such discharges;
    - (3)** Solid or viscous pollutants in amounts that will cause obstruction to the flow in the WWTF resulting in interference;
    - (4)** Any pollutant, including oxygen demanding pollutants (BOD, etc.) released in a discharge at a flow rate and/or pollutant concentration that will cause interference with the WWTF;
    - (5)** Heat in amounts that will inhibit biological activity in the WWTF resulting in interference, but in no case heat in such quantities that the temperature at the WWTF exceeds 40°C (104°F) unless the Regional Water Board, upon request of the Permittee, approves alternate temperature limits;
    - (6)** Petroleum oil, non-biodegradable cutting oil, or products of mineral oil origin in amounts that will cause interferences or pass through; and



operation and disposed of in accordance with applicable federal and state regulations.

- iii. The use and disposal of biosolids shall comply with all of the land application and disposal requirements in 40 C.F.R. part 503, which are enforceable by the U.S. EPA, not the Regional Water Board. If during the life of this Order, the state accepts primacy for implementation of 40 C.F.R. part 503, the Regional Water Board may also initiate enforcement where appropriate.
- iv. Sludge or biosolids that are disposed of in a municipal solid waste landfill or used as daily landfill cover shall meet the applicable requirements of 40 C.F.R. part 258. In the annual self-monitoring report, the Permittee shall report the amount of sludge placed in a landfill and the landfill(s) which received the sludge or biosolids.
- v. The Permittee shall take all reasonable steps to prevent and minimize any sludge use or disposal in violation of this Order that may adversely affect human health or the environment.
- vi. Solids and sludge treatment, storage, and disposal or reuse shall not create a nuisance, such as objectionable odors or flies, and shall not result in groundwater contamination.
- vii. Solids and sludge treatment and storage sites shall have facilities adequate to divert surface water runoff from adjacent areas, to protect the boundaries of the site from erosion, and to prevent drainage from the treatment and storage site. Adequate protection is defined as protection from a design storm with a 100-year recurrence interval and 24-hour duration.
- viii. The discharge of sewage sludge and solids shall not cause waste material to be in a position where it is, or can be, conveyed from the treatment and storage sites and deposited in the waters of the state.

**d. Biosolids Management**

For any discharge of biosolids from the Facility, the Permittee shall comply with the following requirements:

- i. The Permittee submitted a Notice of Intent (NOI), on April 27, 2016, for coverage under the State Water Board General Waste Discharge Requirements for Composting Operations WQ 2015-0121-DWQ (Compost Order). The Permittee shall maintain compliance with the requirements of the Compost Order. If the Permittee would choose to apply biosolids to City owned property, coverage under the State Water Board Order No. 2004-0012-DWQ, General Waste Discharge Requirements for the Discharge of Biosolids to Land as a Soil Amendment in Agricultural, Silvicultural, Horticultural, and Land Reclamation Activities would be required.
- ii. Alternatively, the Permittee may dispose of biosolids at another appropriately permitted facility.
- iii. New sludge treatment and storage facilities must comply with the requirements of the Water Code and title 27 of the CCR for the protection of water quality.



**e. Operator Certification**

Supervisors and operators of municipal wastewater treatment facilities shall possess a certificate of appropriate grade in accordance with title 23, CCR, section 3680. The State Water Board may accept experience in lieu of qualification training. In lieu of a properly certified wastewater treatment facility operator, the State Water Board may approve use of a water treatment facility operator of appropriate grade certified by DDW where water recycling is involved.

**f. Adequate Capacity**

If the Facility will reach capacity within 4 years, the Permittee shall notify the Regional Water Board. A copy of such notification shall be sent to appropriate local elected officials, local permitting agencies, and the press. Factors to be evaluated in assessing reserve capacity shall include, at a minimum, (1) comparison of the wet weather design flow with the highest daily flow, and (2) comparison of the average dry weather design flow with the lowest 30-day flow. The Permittee shall demonstrate that adequate steps are being taken to address the capacity problem. The Permittee shall submit a technical report to the Regional Water Board showing how flow volumes will be prevented from exceeding capacity, or how capacity will be increased, **within 120 days after providing notification to the Regional Water Board**, or within 120 days after receipt of Regional Water Board notification that the Facility will reach capacity within 4 years. The time for filing the required technical report may be extended by the Regional Water Board. An extension of 30 days may be granted by the Executive Officer, and longer extensions may be granted by the Regional Water Board itself. [CCR title 23, section 2232].

**6. Other Special Provisions**

**a. Storm Water**

For the control of storm water discharge from the Facility, if required, the Permittee shall seek separate authorization to discharge under the requirements of the State Water Board's Water Quality Order No. 2014-0057-DWQ, NPDES General Permit No. CAS000001, General Permit for Storm Water Discharges Associated with Industrial Activities (or subsequent renewed versions of the NPDES General Permit CAS000001), which is not incorporated by reference in this Order.

**7. Compliance Schedules**

**a. Compliance Schedule for Final Effluent Limitations for Total Ammonia and Total Nitrate**

The Permittee shall implement activities according to the following schedule to achieve compliance with the effluent limitations for total ammonia and total nitrate established in section IV.A.2.d of this Order.

**Table 6 Schedule for Compliance with Final Effluent Limitations for Total Ammonia and Nitrate**

<b>Task</b>	<b>Task Description</b>	<b>Due Date</b>
<b>1</b>	The Permittee shall submit a Sanitary Sewer Evaluation Survey (SSES) including characterization of the existing collection system, a prioritized list and schedule of repairs for exfiltration, infiltration and inflow reduction.	<b>December, 2018</b>
<b>2</b>	The Permittee shall prepare and submit, for Regional Water Board Executive Officer review and approval, a Technical Report identifying the Preferred Treatment Alternative to address compliance with final effluent limitations for ammonia and nitrate. The Technical Report shall: <ul style="list-style-type: none"> <li>a. Update the Preliminary Engineering Report to reflect changes in assumptions regarding treatment plant loading and updated treatment plant costs.</li> <li>b. Include a conceptual design of the Preferred Treatment Alternative.</li> <li>c. Include project design plans for the Preferred Treatment Alternative;</li> <li>d. Include a cost estimate for the Preferred Treatment Alternative; and</li> <li>e. Include a work plan that lays out the steps and proposed schedule to implement the Preferred Treatment Alternative.</li> </ul>	<b>September 30, 2019</b>
<b>3</b>	The Permittee shall submit a preliminary Report of Waste Discharge (ROWD) based upon the identified Preferred Treatment Alternative. The preliminary ROWD shall include: <ul style="list-style-type: none"> <li>a. Liquid and solids waste treatment technologies Preferred Treatment Alternative;</li> <li>b. Anticipated effluent quality to be achieved by the Preferred Treatment Alternative; and</li> </ul> <p>Evaluation of Preferred Treatment Alternative’s ability to comply with the Final Effluent Limitations for each discharge point and each constituent of concern in the effluent.</p>	<b>December 31, 2019</b>
	The Permittee shall submit documentation that the California Environmental Quality Act (CEQA) process for the Preferred Treatment Alternative identified in Task 3 is complete	<b>December 31, 2020</b>
<b>5</b>	The Permittee shall secure funding for the Preferred Treatment Alternative and provide the Regional Water Board with documentation regarding the funding source(s).	<b>December 31, 2021</b>

<b>Task</b>	<b>Task Description</b>	<b>Due Date</b>
<b>6</b>	The Permittee shall submit a report of completion verifying the complete design plans and specifications for construction of the Preferred Treatment Alternative in conjunction with a complete ROWD.	<b>December 31, 2022</b>
<b>7</b>	The Permittee shall submit a progress report on the advancement of construction for the Preferred Treatment Alternative.	<b>December 31, 2023</b>
<b>8</b>	The Permittee shall complete construction of the Preferred Treatment Alternative and achieve compliance with all Regional Water Board waste discharge requirements including Final Effluent Limitations.	<b>December 31 2024</b>

**VII. COMPLIANCE DETERMINATION**

Compliance with the effluent limitations contained in section IV of this Order will be determined as specified below.

**A. General**

Compliance with effluent limitations for priority pollutants, when effluent limitations have been established, shall be determined using sample reporting protocols defined in the MRP and Attachment A of this Order. For purposes of reporting and administrative enforcement by the Regional and State Water Boards, the Permittee shall be deemed out of compliance with effluent limitations if the concentration of pollutant in the monitoring sample is greater than the effluent limitation and greater than or equal to the reported minimum level (ML).

**B. Multiple Sample Data**

When determining compliance with an AMEL for priority pollutants, and more than one sample result is available, the Permittee shall compute the arithmetic mean unless the data set contains one or more reported determinations of “Detected, but Not Quantified” (DNQ) or “Not Detected” (ND). In those cases, the Permittee shall compute the median in place of the arithmetic mean in accordance with the following procedure.

1. The data set shall be ranked from low to high, ranking the reported ND determinations lowest, DNQ determinations next, followed by quantified values (if any). The order of the individual ND or DNQ determinations is unimportant.
2. The median value of the data set shall be determined. If the data set has an odd number of data points, then the median is the middle value. If the data set has an even number of data points, then the median is the average of the two middle values unless one or both of the points are ND or DNQ, in which case the median value shall be the lower of the two data points where DNQ is lower than a value and ND is lower than DNQ and a value of zero shall be used for the ND or DNQ value in the median calculation for compliance purposes only. Using a value of zero for DNQ or ND samples does not apply when performing reasonable potential or antidegradation analysis.

**C. Average Monthly Effluent Limitation (AMEL)**

If the average (or when applicable, the median determined by subsection B above for multiple sample data) of daily discharges over a calendar month exceeds the AMEL for a given parameter, this will represent a single violation, though the Permittee will be considered out of compliance for each day of that month for that parameter (e.g., resulting in 31 days of non-compliance in a 31-day month). If only a single sample is taken during the calendar month and the analytical result for that sample exceeds the AMEL, the Permittee will be considered out of compliance for that calendar month. The Permittee will only be considered out of compliance for days when the discharge occurs. If there are ND or DNQ results for a specific constituent in a calendar month, the Permittee shall calculate the median of all sample results within that month for compliance determination with the AMEL as described in section VII.B, above.

**D. Average Weekly Effluent Limitation (AWEL)**

If the average (or when applicable, the median determined by subsection B above for multiple sample data) of daily discharges over a calendar week exceeds the AWEL for a given parameter, this will represent a single violation, though the Permittee will be considered out of compliance for each day of that week for that parameter, resulting in 7 days of non-compliance. If only a single sample is taken during the calendar week and the analytical result for that sample exceeds the AWEL, the Permittee will be considered out of compliance for that calendar week. The Permittee will only be considered out of compliance for days when the discharge occurs. If there are ND or DNQ results for a specific constituent in a calendar week, the Permittee shall calculate the median of all sample results within that week for compliance determination with the AWEL as described in section VII.B, above.

**E. Maximum Daily Effluent Limitation (MDEL)**

If a daily discharge (or when applicable, the median determined by subsection B, above, for multiple sample data of a daily discharge) exceeds the MDEL for a given parameter, the Permittee will be considered out of compliance for that parameter for that 1 day only within the reporting period.

**F. Instantaneous Minimum Effluent Limitation**

If the analytical result of a single grab sample is lower than the instantaneous minimum effluent limitation for a parameter, the Permittee will be considered out of compliance for that parameter for that single sample. Non-compliance for each sample will be considered separately (e.g., the results of two grab samples taken within a calendar day that both are lower than the instantaneous minimum effluent limitation would result in two instances of non-compliance with the instantaneous minimum effluent limitation).

If the Permittee monitors pH continuously, pursuant to 40 C.F.R. section 401.17, the Permittee shall be in compliance with the pH limitation specified herein provided that both of the following conditions are satisfied: (1) the total time during which the pH values are outside the required range of pH values shall not exceed 7 hours and 26 minutes in any calendar month; and (2) no individual excursion from the range of pH values shall exceed 60 minutes.

**G. Instantaneous Maximum Effluent Limitation**

If the analytical result of a single grab sample is higher than the instantaneous maximum effluent limitation for a parameter, the Permittee will be considered out of compliance for that parameter for that single sample. Non-compliance for each sample will be considered separately (e.g., the

results of two grab samples taken within a calendar day that both exceed the instantaneous maximum effluent limitation would result in two instances of non-compliance with the instantaneous maximum effluent limitation).

If the Permittee monitors pH continuously, pursuant to 40 C.F.R. section 401.17, the Permittee shall be in compliance with the pH limitation specified herein provided that both of the following conditions are satisfied: (1) the total time during which the pH values are outside the required range of pH values shall not exceed 7 hours and 26 minutes in any calendar month; and (2) no individual excursion from the range of pH values shall exceed 60 minutes.

#### **H. Bacteriological Limitations (Total Coliform)**

- 1. Median.** The median is the central tendency concentration of the pollutant. The data set shall be ranked from low to high, ranking the ND concentrations lowest, followed by quantified values. The median value is determined based on the number of data points in the set. If the data set has an odd number of data points, then the median is the middle value. If the data set has an even number of data points, the median is the average of the two middle values, unless one or both points are ND or DNQ, in which case the median value shall be the lower of the two middle data points. DNQ is lower than a detected value, and ND is lower than DNQ.
- 2.** Compliance with the 7-day median will be determined as a rolling median during periods when sampling occurs more frequently than weekly. During periods when sampling is weekly, this requirement shall apply to each weekly sample.

#### **I. Acute Toxicity Limitations**

Compliance with the three-sample median acute toxicity effluent limitation shall be determined when there is a discharge, by calculating the median percent survival of the three most recent consecutive samples meeting all test acceptability criteria collected from Monitoring Location EFF-001.

Compliance with the accelerated monitoring and TRE provisions shall constitute compliance with the acute toxicity requirements, all specified in the MRP (Attachment E, sections V.A and V.C).

#### **J. Chronic Toxicity**

Compliance with the accelerated monitoring and TRE provisions specified in the MRP (Attachment E, sections V.B.8 and V.C) shall constitute compliance with the narrative chronic toxicity requirement specified as Effluent Limitation IV.A.1.E. The MRP, section V.B.6.a, further describes how a determination of Pass/Fail shall be made.

#### **K. Average Dry Weather Flow**

Compliance with the average dry weather flow prohibition in section III.H of this Order will be determined once each calendar year by evaluating all flow data collected in a calendar year. The flow through the facility, measured daily and averaged monthly, must be 1.5 mgd or less for the month with the lowest average monthly flow.

#### **L. Peak Daily Wet Weather Flow**

The peak daily wet weather flow is the maximum flow rate that occurs over a 24-hour period. Compliance with the peak daily wet weather flow prohibition in section III.H of this Order will be determined daily by measuring the daily average flow at Monitoring Point INF-001. If the

measured daily average flow exceeds 7.0 mgd, the discharge is not in compliance with Prohibition III.H of this Order.

**M. Total Chlorine Residual**

Compliance with the chlorine residual effluent limitations shall be based on continuous chlorine residual monitoring at Monitoring Location EFF-001 and EFF-003. The Permittee shall report from discrete readings of the continuous monitoring every hour on the hour. Compliance shall be based on an average of these discrete hourly readings on a daily basis. The Permittee shall retain continuous monitoring readings for at least three years. The Regional Water Board retains the right to use all continuous monitoring data for discretionary enforcement.

## ATTACHMENT A – DEFINITIONS

### **Arithmetic Mean ( $\mu$ )**

Also called the average is the sum of measured values divided by the number of samples. For ambient water concentrations, the arithmetic mean is calculated as follows:

Arithmetic mean =  $\mu = \Sigma x / n$       where:  $\Sigma x$  is the sum of the measured ambient water concentrations, and  $n$  is the number of samples.

### **Average Monthly Effluent Limitation (AMEL)**

The highest allowable average of daily discharges over a calendar month, calculated as the sum of all daily discharges measured during a calendar month divided by the number of daily discharges measured during that month.

### **Average Weekly Effluent Limitation (AWEL)**

The highest allowable average of daily discharges over a calendar week (Sunday through Saturday), calculated as the sum of all daily discharges measured during a calendar week divided by the number of daily discharges measured during that week.

### **Bioaccumulative Pollutants**

Substances taken up by an organism from its surrounding medium through gill membranes, epithelial tissue, or from food and subsequently concentrated and retained in the body of the organism.

### **Coefficient of Variation (CV)**

A measure of the data variability and is calculated as the estimated standard deviation divided by the arithmetic mean of the observed values.

### **Daily Discharge**

Daily Discharge is defined as either: (1) the total mass of the constituent discharged over the calendar day (12:00 am through 11:59 pm) or any 24-hour period that reasonably represents a calendar day for purposes of sampling (as specified in the permit), for a constituent with limitations expressed in units of mass or; (2) the unweighted arithmetic mean measurement of the constituent over the day for a constituent with limitations expressed in other units of measurement (e.g., concentration).

The daily discharge may be determined by the analytical results of a composite sample taken over the course of one day (a calendar day or other 24-hour period defined as a day) or by the arithmetic mean of analytical results from one or more grab samples taken over the course of the day.

For composite sampling, if 1 day is defined as a 24-hour period other than a calendar day, the analytical result for the 24-hour period will be considered as the result for the calendar day in which the 24-hour period ends.

### **Detected, but Not Quantified (DNQ)**

Sample results that are less than the reported Minimum Level, but greater than or equal to the laboratory's MDL. Sample results reported as DNQ are estimated concentrations.

### **Dilution Credit**

The amount of dilution granted to a discharge in the calculation of a water quality-based effluent limitation, based on the allowance of a specified mixing zone. It is calculated from the dilution ratio or determined through conducting a mixing zone study or modeling of the discharge and receiving water.

### **Effective Concentration (EC)**

A point estimate of the toxicant concentration that would cause an adverse effect on a quantal, "all or nothing," response (such as death, immobilization, or serious incapacitation) in a given percent of the test organisms. If the effect is death or immobility, the term lethal concentration (LC) may be used. EC values may be calculated using point estimation techniques such as probit, logit, and Spearman-Kärber. EC25 is the concentration of toxicant (in percent effluent) that causes a response in 25 percent of the test organisms.

### **Effluent Concentration Allowance (ECA)**

A value derived from the water quality criterion/objective, dilution credit, and ambient background concentration that is used, in conjunction with the coefficient of variation for the effluent monitoring data, to calculate a long-term average (LTA) discharge concentration. The ECA has the same meaning as waste load allocation (WLA) as used in U.S. EPA guidance (Technical Support Document For Water Quality-based Toxics Control, March 1991, second printing, EPA/505/2-90-001).

### **Enclosed Bays**

Indentations along the coast that enclose an area of oceanic water within distinct headlands or harbor works. Enclosed bays include all bays where the narrowest distance between headlands or outermost harbor works is less than 75 percent of the greatest dimension of the enclosed portion of the bay. This definition includes but is not limited to: Humboldt Bay, Bodega Harbor, Tomales Bay, Drakes Estero, San Francisco Bay, Morro Bay, Los Angeles Harbor, Upper and Lower Newport Bay, Mission Bay, and San Diego Bay.

### **Estimated Chemical Concentrations**

The estimated chemical concentration that results from the confirmed detection of the substance by the analytical method below the ML value.

**Estuaries and Coastal Lagoons** are waters at the mouths of streams that serve as mixing zones for fresh and ocean waters during a major portion of the year. Mouths of streams that are temporarily separated from the ocean by sandbars shall be considered as estuaries. Estuarine waters will generally be considered to extend from a bay or the open ocean to the upstream limit of tidal action but may be considered to extend seaward if significant mixing of fresh and salt water occurs in the open coastal waters. The waters described by this definition include but are not limited to the Sacramento-San Joaquin Delta as defined by Section 12220 of the California Water Code, Suisun Bay, Carquinez Strait downstream to Carquinez Bridge, and appropriate areas of the Smith, Klamath, Mad, Eel, Noyo, Russian, San Diego, and Otay Rivers. Estuaries do not include inland surface waters or ocean waters.

### **Inhibition Concentration (IC)**

The IC25 is typically calculated as a percentage of effluent. It is the level at which the organisms exhibit 25 percent reduction in biological measurement such as reproduction or growth. It is calculated statistically and used in chronic toxicity testing.



### **Inland Surface Waters**

All surface waters of the State that do not include the ocean, enclosed bays, or estuaries.

### **Instantaneous Maximum Effluent Limitation**

The highest allowable value for any single grab sample or aliquot (i.e., each grab sample or aliquot is independently compared to the instantaneous maximum limitation).

### **Instantaneous Minimum Effluent Limitation**

The lowest allowable value for any single grab sample or aliquot (i.e., each grab sample or aliquot is independently compared to the instantaneous minimum limitation).

### **Lowest Observed Effect Concentration (LOEC)**

The lowest concentration of an effluent or toxicant that results in adverse effects on the test organism (i.e., where the values for the observed endpoints are statistically different from the control).

### **Maximum Daily Effluent Limitation (MDEL)**

The highest allowable daily discharge of a pollutant, over a calendar day (or 24-hour period). For pollutants with limitations expressed in units of mass, the daily discharge is calculated as the total mass of the pollutant discharged over the day. For pollutants with limitations expressed in other units of measurement, the daily discharge is calculated as the arithmetic mean measurement of the pollutant over the day.

### **Median**

The middle measurement in a set of data. The median of a set of data is found by first arranging the measurements in order of magnitude (either increasing or decreasing order). If the number of measurements ( $n$ ) is odd, then the median =  $X_{(n+1)/2}$ . If  $n$  is even, then the median =  $(X_{n/2} + X_{(n/2)+1})/2$  (i.e., the midpoint between the  $n/2$  and  $n/2+1$ ).

### **Method Detection Limit (MDL)**

The minimum concentration of a substance that can be measured and reported with 99 percent confidence that the analyte concentration is greater than zero, as defined in 40 C.F.R. part 136, Attachment B, revised as of July 3, 1999.

### **Minimum Level (ML)**

The concentration at which the entire analytical system must give a recognizable signal and acceptable calibration point. The ML is the concentration in a sample that is equivalent to the concentration of the lowest calibration standard analyzed by a specific analytical procedure, assuming that all the method specified sample weights, volumes, and processing steps have been followed.

### **Mixing Zone**

A limited volume of receiving water that is allocated for mixing with a wastewater discharge where water quality criteria can be exceeded without causing adverse effects to the overall water body.

### **Not Detected (ND)**

Those sample results less than the laboratory's MDL.

**No Observed Effect Concentration (NOEC)**

The highest tested concentration of an effluent or a test sample at which the effect is no different from the control effect, according to the statistical test used (see LOEC). The NOEC is usually the highest tested concentration of an effluent or toxicant that causes no observable effects on the aquatic test organisms (i.e., the highest concentration of toxicity at which the values for the observed responses do not statistically differ from the controls). It is determined using hypothesis testing.

**Persistent Pollutants**

Substances for which degradation or decomposition in the environment is nonexistent or very slow.

**Pollutant Minimization Program (PMP)**

PMP means waste minimization and pollution prevention actions that include, but are not limited to, product substitution, waste stream recycling, alternative waste management methods, and education of the public and businesses. The goal of the PMP shall be to reduce all potential sources of a priority pollutant(s) through pollutant minimization (control) strategies, including pollution prevention measures as appropriate, to maintain the effluent concentration at or below the water quality-based effluent limitation. Pollution prevention measures may be particularly appropriate for persistent bioaccumulative priority pollutants where there is evidence that beneficial uses are being impacted. The Regional Water Board may consider cost effectiveness when establishing the requirements of a PMP. The completion and implementation of a Pollution Prevention Plan, if required pursuant to Water Code section 13263.3(d), shall be considered to fulfill the PMP requirements.

**Pollution Prevention**

Any action that causes a net reduction in the use or generation of a hazardous substance or other pollutant that is discharged into water and includes, but is not limited to, input change, operational improvement, production process change, and product reformulation (as defined in Water Code section 13263.3). Pollution prevention does not include actions that merely shift a pollutant in wastewater from one environmental medium to another environmental medium, unless clear environmental benefits of such an approach are identified to the satisfaction of the State or Regional Water Board.

**Publicly Owned Treatment Works (POTW)**

A treatment works as defined in section 212 of the Clean Water Act (CWA), which is owned by a State or municipality as defined by section 502(4) of the CWA. [Section 502(4) of the CWA defines a municipality as a city, town, borough, county, parish, district, association, or other public body created by or pursuant to State law and having jurisdiction over disposal of sewage, industrial wastes, or other wastes). This definition includes any devices and systems used in the storage, treatment, recycling, and reclamation of municipal sewage or industrial wastes of a liquid nature. It also includes sewers, pipes and other conveyances only if they convey wastewater to a POTW Treatment Plant. The term also means the municipality as defined in section 502(4) of the CWA, which has jurisdiction over the Indirect Discharges to and the discharges from such a treatment works.

**Recycled Water**

Water which, as a result of treatment of municipal wastewater, is suitable for a direct beneficial use or a controlled use that would not otherwise occur and is therefore considered a valuable resource (Water Code section 13050). The terms “recycled water” and “reclaimed water” have the same meaning (Water Code section 26).

### **Reporting Level (RL)**

The ML (and its associated analytical method) used for reporting and compliance determination. The MLs included in this Order correspond to approved analytical methods for reporting a sample result that are selected by the Regional Water Board either from Appendix 4 of the SIP in accordance with section 2.4.2 of the SIP or established in accordance with section 2.4.3 of the SIP. The ML is based on the proper application of method-based analytical procedures for sample preparation and the absence of any matrix interferences. Other factors may be applied to the ML depending on the specific sample preparation steps employed. For example, the treatment typically applied in cases where there are matrix-effects is to dilute the sample or sample aliquot by a factor of ten. In such cases, this additional factor must be applied to the ML in the computation of the RL.

### **Septage**

Defined as the liquid or solid material removed from a septic tank, cesspool, portable toilet, type III marine sanitation device, recreational vehicle's sanitation tank, or similar storage or treatment works that receives domestic waste.

### **Source of Drinking Water**

Any water designated as municipal or domestic supply (MUN) in a Regional Water Board Basin Plan.

### **Standard Deviation ( $\sigma$ )**

A measure of variability that is calculated as follows:

$$\sigma = (\sum[(x - \mu)^2]/(n - 1))^{0.5}$$

where:

x is the observed value;

$\mu$  is the arithmetic mean of the observed values; and

n is the number of samples.

### **Toxicity Reduction Evaluation (TRE)**

A study conducted in a step-wise process designed to identify the causative agents of effluent or ambient toxicity, isolate the sources of toxicity, evaluate the effectiveness of toxicity control options, and then confirm the reduction in toxicity. The first steps of the TRE consist of the collection of data relevant to the toxicity, including additional toxicity testing, and an evaluation of facility operations and maintenance practices, and best management practices. A Toxicity Identification Evaluation (TIE) may be required as part of the TRE, if appropriate. (A TIE is a set of procedures to identify the specific chemical(s) responsible for toxicity. These procedures are performed in three phases (characterization, identification, and confirmation) using aquatic organism toxicity tests.)

### **Test of Significant Toxicity (TST)**

The statistical approach described in National Pollutant Discharge Elimination System Test of Significant Toxicity Implementation Document (EPA 833-R10-003, 2010). TST was developed by the U.S. Environmental Protection Agency (EPA) for analyzing WET and ambient toxicity data. Using the TST approach, the sample is declared toxic if there is greater than or equal to a 25% effect in chronic tests, or if there is greater than or equal to a 20% effect in acute tests at the permitted instream waste concentration (IWC) (referred to as the toxic regulatory management decision (RMD)). The sample is declared non-toxic if there is less than or equal to a 10% effect at the IWC in acute or chronic tests (referred to as the non-toxic RMD).

ATTACHMENT B - MAP

# City of Fortuna Municipal Wastewater Treatment Plant





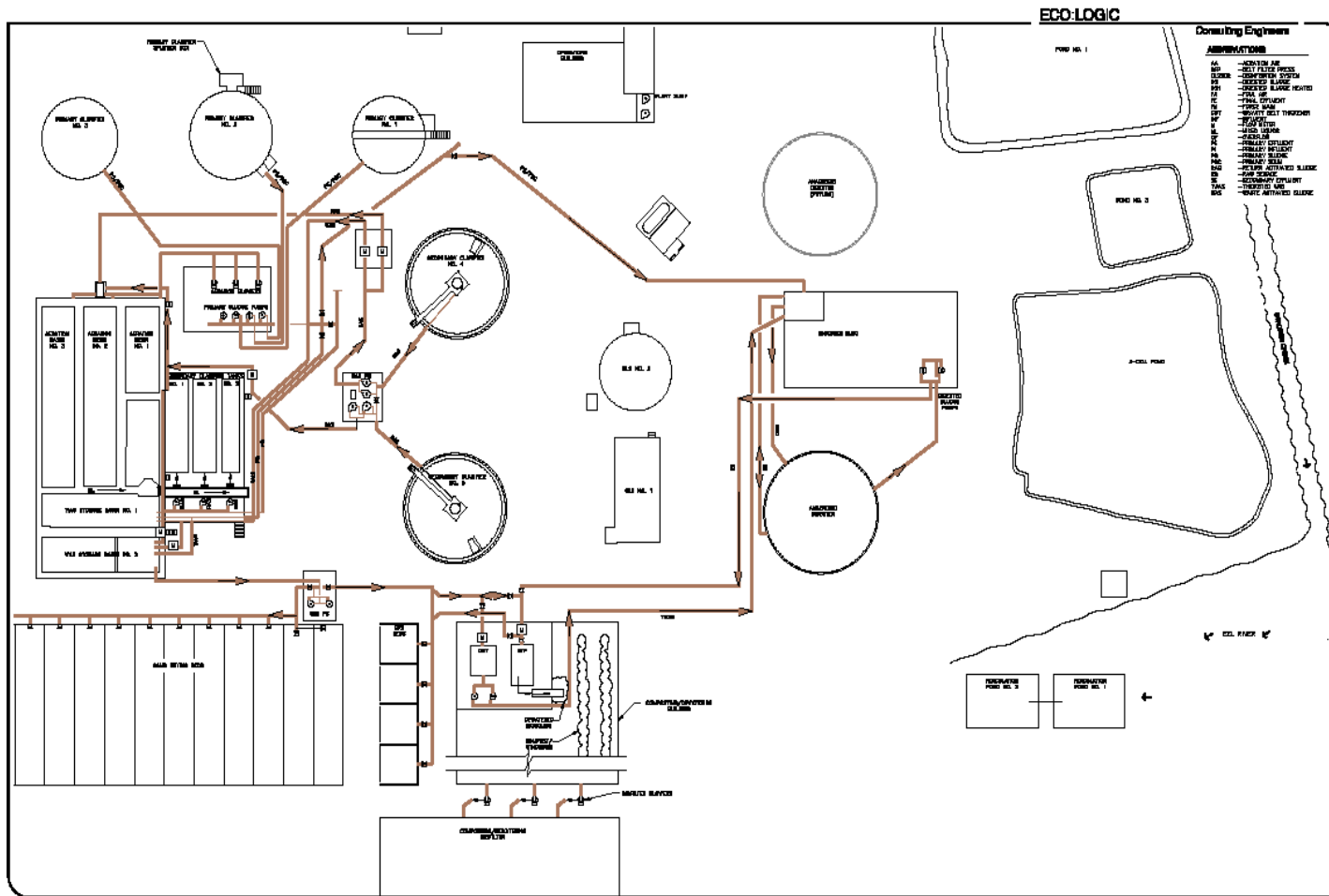
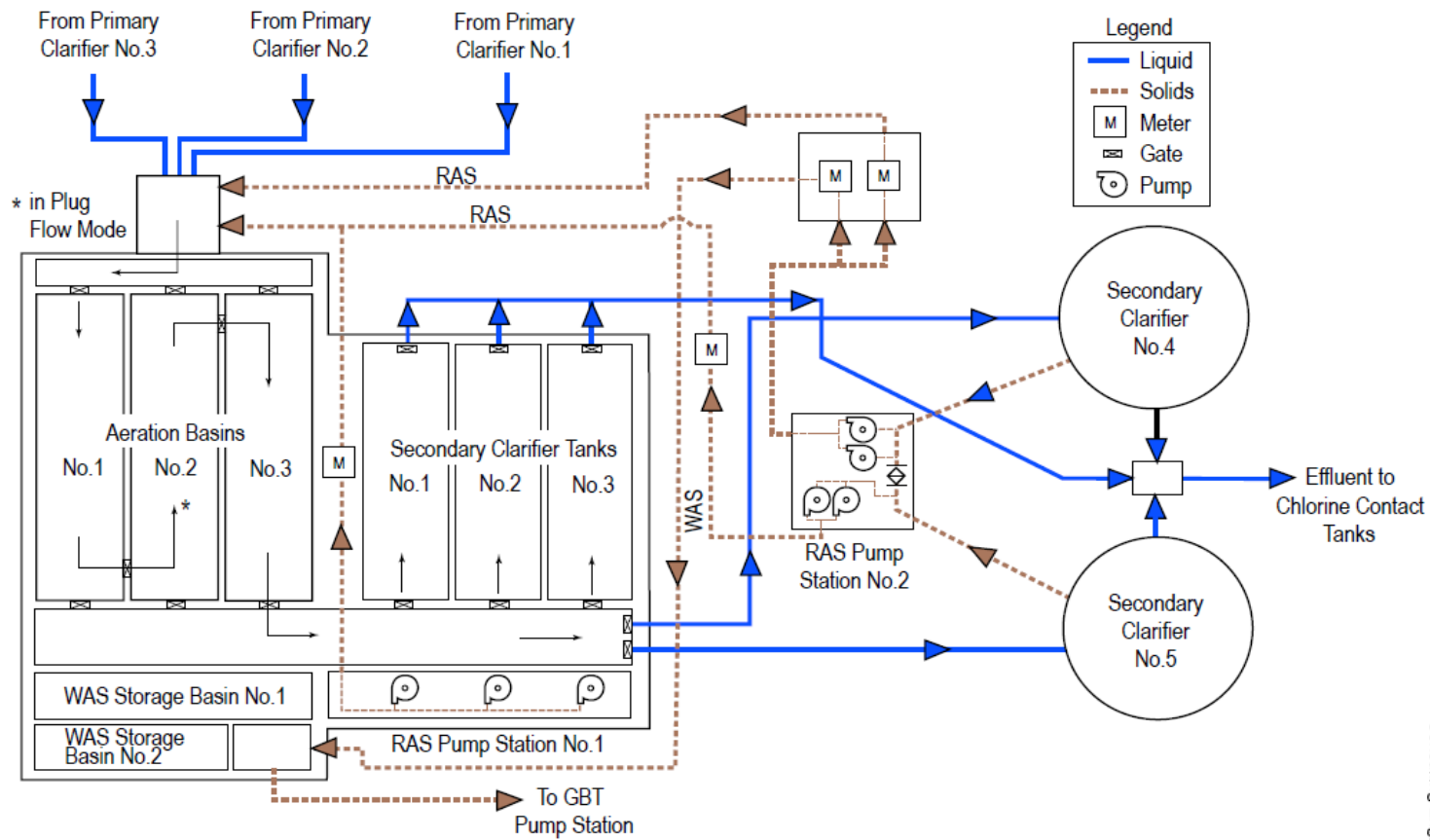

FIGURE 1-2  
 SOLIDS TRAIN DIAGRAM

Figure C-3. Secondary Treatment Process Schematic



ECO:LOGIC  
 Consulting Engineers

## ATTACHMENT D – STANDARD PROVISIONS

### I. STANDARD PROVISIONS – PERMIT COMPLIANCE

#### A. Duty to Comply

1. The Permittee must comply with all of the conditions of this Order. Any noncompliance constitutes a violation of the Clean Water Act (CWA) and the California Water Code and is grounds for enforcement action, for permit termination, revocation and reissuance, or modification; denial of a permit renewal application; or a combination thereof. (40 C.F.R. § 122.41(a); Wat. Code, §§ 13261, 13263, 13265, 13268, 13000, 13001, 13304, 13350, 13385.)
2. The Permittee shall comply with effluent standards or prohibitions established under Section 307(a) of the CWA for toxic pollutants and with standards for sewage sludge use or disposal established under Section 405(d) of the CWA within the time provided in the regulations that establish these standards or prohibitions, even if this Order has not yet been modified to incorporate the requirement. (40 C.F.R. § 122.41(a)(1).)

#### B. Need to Halt or Reduce Activity Not a Defense

It shall not be a defense for a Permittee in an enforcement action that it would have been necessary to halt or reduce the permitted activity in order to maintain compliance with the conditions of this Order. (40 C.F.R. § 122.41(c).)

#### C. Duty to Mitigate

The Permittee shall take all reasonable steps to minimize or prevent any discharge or sludge use or disposal in violation of this Order that has a reasonable likelihood of adversely affecting human health or the environment. (40 C.F.R. § 122.41(d).)

#### D. Proper Operation and Maintenance

The Permittee shall at all times properly operate and maintain all facilities and systems of treatment and control (and related appurtenances) which are installed or used by the Permittee to achieve compliance with the conditions of this Order. Proper operation and maintenance also includes adequate laboratory controls and appropriate quality assurance procedures. This provision requires the operation of backup or auxiliary facilities or similar systems that are installed by a Permittee only when necessary to achieve compliance with the conditions of this Order. (40 C.F.R. § 122.41(e).)

#### E. Property Rights

1. This Order does not convey any property rights of any sort or any exclusive privileges. (40 C.F.R. § 122.41(g).)
2. The issuance of this Order does not authorize any injury to persons or property or invasion of other private rights, or any infringement of state or local law or regulations. (40 C.F.R. § 122.5(c).)

#### F. Inspection and Entry

The Permittee shall allow the Regional Water Board, State Water Board, U.S. EPA, and/or their authorized representatives (including an authorized contractor acting as their representative),



upon the presentation of credentials and other documents, as may be required by law, to (33 U.S.C. § 1318(a)(4)(b)(i); 40 C.F.R. § 122.41(i); Wat. Code, §§ 13267, 13383):

1. Enter upon the Permittee's premises where a regulated facility or activity is located or conducted, or where records are kept under the conditions of this Order (33 U.S.C. § 1318(a)(4)(b)(i); 40 C.F.R. § 122.41(i)(1); Wat. Code, §§ 13267, 13383);
2. Have access to and copy, at reasonable times, any records that must be kept under the conditions of this Order (33 U.S.C. § 1318(a)(4)(b)(ii); 40 C.F.R. § 122.41(i)(2); Wat. Code, §§ 13267, 13383);
3. Inspect and photograph, at reasonable times, any facilities, equipment (including monitoring and control equipment), practices, or operations regulated or required under this Order (33 U.S.C. § 1318(a)(4)(b)(ii); 40 C.F.R. § 122.41(i)(3); Wat. Code, §§ 13267, 13383); and
4. Sample or monitor, at reasonable times, for the purposes of assuring Order compliance or as otherwise authorized by the CWA or the Water Code, any substances or parameters at any location. (33 U.S.C. § 1318(a)(4)(b); 40 C.F.R. § 122.41(i)(4); Wat. Code, §§ 13267, 13383.)

## G. Bypass

### 1. Definitions

- a. "Bypass" means the intentional diversion of waste streams from any portion of a treatment facility. (40 C.F.R. § 122.41(m)(1)(i).)
- b. "Severe property damage" means substantial physical damage to property, damage to the treatment facilities, which causes them to become inoperable, or substantial and permanent loss of natural resources that can reasonably be expected to occur in the absence of a bypass. Severe property damage does not mean economic loss caused by delays in production. (40 C.F.R. § 122.41(m)(1)(ii).)

2. **Bypass not exceeding limitations.** The Permittee may allow any bypass to occur which does not cause exceedances of effluent limitations, but only if it is for essential maintenance to assure efficient operation. These bypasses are not subject to the provisions listed in Standard Provisions – Permit Compliance I.G.3, I.G.4, and I.G.5 below. (40 C.F.R. § 122.41(m)(2).)

3. **Prohibition of bypass.** Bypass is prohibited, and the Regional Water Board may take enforcement action against a Permittee for bypass, unless (40 C.F.R. § 122.41(m)(4)(i)):

- a. Bypass was unavoidable to prevent loss of life, personal injury, or severe property damage (40 C.F.R. § 122.41(m)(4)(i)(A));
- b. There were no feasible alternatives to the bypass, such as the use of auxiliary treatment facilities, retention of untreated wastes, or maintenance during normal periods of equipment downtime. This condition is not satisfied if adequate back-up equipment should have been installed in the exercise of reasonable engineering judgment to prevent a bypass that occurred during normal periods of equipment downtime or preventive maintenance (40 C.F.R. § 122.41(m)(4)(i)(B)); and
- c. The Permittee submitted notice to the Regional Water Board as required under Standard Provisions – Permit Compliance I.G.5 below. (40 C.F.R. § 122.41(m)(4)(i)(C).)

4. **Burden of Proof.** In any enforcement proceeding, the permittee seeking to establish the bypass defense has the burden of proof.
5. The Regional Water Board may approve an anticipated bypass, after considering its adverse effects, if the Regional Water Board determines that it will meet the three conditions listed in Standard Provisions – Permit Compliance I.G.3 above. (40 C.F.R. § 122.41(m)(4)(ii).)
6. **Notice**
  - a. **Anticipated bypass.** If the Permittee knows in advance of the need for a bypass, it shall submit a prior notice, if possible at least 10 days before the date of the bypass. (40 C.F.R. § 122.41(m)(3)(i).)
  - b. **Unanticipated bypass.** The Permittee shall submit notice of an unanticipated bypass as required in Standard Provisions - Reporting V.E below (24-hour notice). (40 C.F.R. § 122.41(m)(3)(ii).)

#### H. Upset

Upset means an exceptional incident in which there is unintentional and temporary noncompliance with technology based permit effluent limitations because of factors beyond the reasonable control of the Permittee. An upset does not include noncompliance to the extent caused by operational error, improperly designed treatment facilities, inadequate treatment facilities, lack of preventive maintenance, or careless or improper operation. (40 C.F.R. § 122.41(n)(1).)

1. **Effect of an upset.** An upset constitutes an affirmative defense to an action brought for noncompliance with such technology based permit effluent limitations if the requirements of Standard Provisions – Permit Compliance I.H.2 below are met. No determination made during administrative review of claims that noncompliance was caused by upset, and before an action for noncompliance, is final administrative action subject to judicial review. (40 C.F.R. § 122.41(n)(2).)
2. **Conditions necessary for a demonstration of upset.** A Permittee who wishes to establish the affirmative defense of upset shall demonstrate, through properly signed, contemporaneous operating logs or other relevant evidence that (40 C.F.R. § 122.41(n)(3)):
  - a. An upset occurred and that the Permittee can identify the cause(s) of the upset (40 C.F.R. § 122.41(n)(3)(i));
  - b. The permitted facility was, at the time, being properly operated (40 C.F.R. § 122.41(n)(3)(ii));
  - c. The Permittee submitted notice of the upset as required in Standard Provisions – Reporting V.E.2.b below (24-hour notice) (40 C.F.R. § 122.41(n)(3)(iii)); and
  - d. The Permittee complied with any remedial measures required under Standard Provisions – Permit Compliance I.C above. (40 C.F.R. § 122.41(n)(3)(iv).)
3. **Burden of Proof.** In any enforcement proceeding, the Permittee seeking to establish the occurrence of an upset has the burden of proof. (40 C.F.R. § 122.41(n)(4).)

## **II. STANDARD PROVISIONS – PERMIT ACTION**

### **A. General**

This Order may be modified, revoked and reissued, or terminated for cause. The filing of a request by the Permittee for modification, revocation and reissuance, or termination, or a notification of planned changes or anticipated noncompliance does not stay any Order condition. (40 C.F.R. § 122.41(f).)

### **B. Duty to Reapply**

If the Permittee wishes to continue an activity regulated by this Order after the expiration date of this Order, the Permittee must apply for and obtain a new permit. (40 C.F.R. § 122.41(b).)

### **C. Transfers**

This Order is not transferable to any person except after notice to the Regional Water Board. The Regional Water Board may require modification or revocation and reissuance of the Order to change the name of the Permittee and incorporate such other requirements as may be necessary under the CWA and the Water Code. (40 C.F.R. § 122.41(l)(3); § 122.61.)

## **III. STANDARD PROVISIONS – MONITORING**

**A.** Samples and measurements taken for the purpose of monitoring shall be representative of the monitored activity. (40 C.F.R. § 122.41(j)(1).)

**B.** Monitoring must be conducted according to test procedures under 40 C.F.R. part 136 for the analyses of pollutants unless another method is required under 40 C.F.R., chapter 1, subchapters N or O. Monitoring must be conducted according to sufficiently sensitive test procedures (i.e., methods) approved under 40 C.F.R. part 136 for the analysis of pollutants or pollutant parameters or required under 40 C.F.R. chapter 1, subchapter N or O. For the purposes of this paragraph, a method is “sufficiently sensitive” when:

1. The method minimum level (ML) is at or below the level of the effluent limitation established in the permit for the measured pollutant or pollutant parameter, and, either the method ML is at or below the level of the applicable water quality criterion for the measured pollutant or pollutant parameter or the method ML is above the applicable water quality criterion, but the amount of the pollutant or pollutant parameter in a facility’s discharge is high enough that the method detects and quantifies the level of the pollutant or pollutant parameter in the discharge; or
2. The method has the lowest ML of the analytical methods approved under 40 C.F.R. part 136 or required under 40 C.F.R. chapter 1, subchapter N or O for the measured pollutant or pollutant parameter.

In the case of pollutants for which there are no approved methods under 40 C.F.R. part 136 or otherwise required under 40 C.F.R. chapter 1, subchapters N or O, monitoring must be conducted according to a test procedure specified in this Order for such pollutants. (40 C.F.R. § 122.41(j)(4); § 122.44(i)(1)(iv).)

In the case of sludge use or disposal approved under 40 C.F.R. part 136, monitoring must be conducted according to test procedures in part 503 unless otherwise specified in 40 C.F.R. or other test procedures have been specified in this Order.

#### **IV. STANDARD PROVISIONS – RECORDS**

- A.** Except for records of monitoring information required by this Order related to the Permittee's sewage sludge use and disposal activities, which shall be retained for a period of at least five years (or longer as required by 40 C.F.R. part 503), the Permittee shall retain records of all monitoring information, including all calibration and maintenance records and all original strip chart recordings for continuous monitoring instrumentation, copies of all reports required by this Order, and records of all data used to complete the application for this Order, for a period of at least three (3) years from the date of the sample, measurement, report or application. This period may be extended by request of the Regional Water Board Executive Officer at any time. (40 C.F.R. § 122.41(j)(2).)
- B. Records of monitoring information shall include:**
1. The date, exact place, and time of sampling or measurements (40 C.F.R. § 122.41(j)(3)(i));
  2. The individual(s) who performed the sampling or measurements (40 C.F.R. § 122.41(j)(3)(ii));
  3. The date(s) analyses were performed (40 C.F.R. § 122.41(j)(3)(iii));
  4. The individual(s) who performed the analyses (40 C.F.R. § 122.41(j)(3)(iv));
  5. The analytical techniques or methods used (40 C.F.R. § 122.41(j)(3)(v)); and
  6. The results of such analyses. (40 C.F.R. § 122.41(j)(3)(vi).)
- C. Claims of confidentiality for the following information will be denied (40 C.F.R. § 122.7(b)):**
1. The name and address of any permit applicant or Permittee (40 C.F.R. § 122.7(b)(1)); and
  2. Permit applications and attachments, permits and effluent data. (40 C.F.R. § 122.7(b)(2).)

#### **V. STANDARD PROVISIONS – REPORTING**

**A. Duty to Provide Information**

The Permittee shall furnish to the Regional Water Board, State Water Board, or U.S. EPA within a reasonable time, any information which the Regional Water Board, State Water Board, or U.S. EPA may request to determine whether cause exists for modifying, revoking and reissuing, or terminating this Order or to determine compliance with this Order. Upon request, the Permittee shall also furnish to the Regional Water Board, State Water Board, or U.S. EPA copies of records required to be kept by this Order. (40 C.F.R. § 122.41(h); Wat. Code, § 13267.)

**B. Signatory and Certification Requirements**

1. All applications, reports, or information submitted to the Regional Water Board, State Water Board, and/or U.S. EPA shall be signed and certified in accordance with Standard Provisions – Reporting V.B.2, V.B.3, V.B.4, and V.B.5 below. (40 C.F.R. § 122.41(k).)
2. All permit applications shall be signed by either a principal executive officer or ranking elected official. For purposes of this provision, a principal executive officer of a federal agency includes: (i) the chief executive officer of the agency, or (ii) a senior executive officer having responsibility for the overall operations of a principal geographic unit of the agency (e.g., Regional Administrators of U.S. EPA). (40 C.F.R. § 122.22(a)(3).)

3. All reports required by this Order and other information requested by the Regional Water Board, State Water Board, or U.S. EPA shall be signed by a person described in Standard Provisions – Reporting V.B.2 above, or by a duly authorized representative of that person. A person is a duly authorized representative only if:
  - a. The authorization is made in writing by a person described in Standard Provisions – Reporting V.B.2 above (40 C.F.R. § 122.22(b)(1));
  - b. The authorization specifies either an individual or a position having responsibility for the overall operation of the regulated facility or activity such as the position of plant manager, operator of a well or a well field, superintendent, position of equivalent responsibility, or an individual or position having overall responsibility for environmental matters for the company. (A duly authorized representative may thus be either a named individual or any individual occupying a named position.) (40 C.F.R. § 122.22(b)(2)); and
  - c. The written authorization is submitted to the Regional Water Board and State Water Board. (40 C.F.R. § 122.22(b)(3).)
4. If an authorization under Standard Provisions – Reporting V.B.3 above is no longer accurate because a different individual or position has responsibility for the overall operation of the facility, a new authorization satisfying the requirements of Standard Provisions – Reporting V.B.3 above must be submitted to the Regional Water Board and State Water Board prior to or together with any reports, information, or applications, to be signed by an authorized representative. (40 C.F.R. § 122.22(c).)
5. Any person signing a document under Standard Provisions – Reporting V.B.2 or V.B.3 above shall make the following certification:

“I certify under penalty of law that this document and all attachments were prepared under my direction or supervision in accordance with a system designed to assure that qualified personnel properly gather and evaluate the information submitted. Based on my inquiry of the person or persons who manage the system or those persons directly responsible for gathering the information, the information submitted is, to the best of my knowledge and belief, true, accurate, and complete. I am aware that there are significant penalties for submitting false information, including the possibility of fine and imprisonment for knowing violations.” (40 C.F.R. § 122.22(d).)
6. Any person providing the electronic signature for documents described in Standard Provisions – V.B.1, V.B.2, or V.B.3 that are submitted electronically shall meet all relevant requirements of Standard Provisions – Reporting V.B, and shall ensure that all relevant requirements of 40 C.F.R. part 3 (Cross-Media Electronic Reporting) and 40 C.F.R. part 127 (NPDES Electronic Reporting Requirements) are met for that submission. (40 C.F.R. § 122.22(e).)

**C. Monitoring Reports**

1. Monitoring results shall be reported at the intervals specified in the Monitoring and Reporting Program (Attachment E) in this Order. (40 C.F.R. § 122.41(l)(4).)
2. Monitoring results must be reported on a Discharge Monitoring Report (DMR) form or forms provided or specified by the Regional Water Board or State Water Board for reporting

results of monitoring, sludge use, or disposal practices. As of December 21, 2016, all reports and forms must be submitted electronically to the initial recipient defined in Standard Provisions – Reporting V.J and comply with 40 C.F.R. part 3, 40 C.F.R. section 122.22, and 40 C.F.R. part 127. (40 C.F.R. § 122.41(l)(4)(i).)

3. If the Permittee monitors any pollutant more frequently than required by this Order using test procedures approved under 40 C.F.R. part 136, or another method required for an industry-specific waste stream under 40 C.F.R. chapter 1, subchapters N or O, the results of such monitoring shall be included in the calculation and reporting of the data submitted in the DMR or sludge reporting form specified by the Regional Water Board. (40 C.F.R. § 122.41(l)(4)(ii).)
4. Calculations for all limitations, which require averaging of measurements, shall utilize an arithmetic mean unless otherwise specified in this Order. (40 C.F.R. § 122.41(l)(4)(iii).)

#### **D. Compliance Schedules**

Reports of compliance or noncompliance with, or any progress reports on, interim and final requirements contained in any compliance schedule of this Order, shall be submitted no later than 14 days following each schedule date. (40 C.F.R. § 122.41(l)(5).)

#### **E. Twenty-Four Hour Reporting**

1. The Permittee shall report any noncompliance that may endanger health or the environment. Any information shall be provided orally within 24 hours from the time the Permittee becomes aware of the circumstances. A written submission shall also be provided within five (5) days of the time the Permittee becomes aware of the circumstances. The written submission shall contain a description of the noncompliance and its cause; the period of noncompliance, including exact dates and times, and if the noncompliance has not been corrected, the anticipated time it is expected to continue; and steps taken or planned to reduce, eliminate, and prevent reoccurrence of the noncompliance. (40 C.F.R. § 122.41(l)(6)(i).)

For noncompliance events related to combined sewer overflows, sanitary sewer overflows, or bypass events, these reports must include the data described above (with the exception of time of discovery) as well as the type of event (i.e., combined sewer overflow, sanitary sewer overflow, or bypass event), type of overflow structure (e.g., manhole, combined sewer overflow outfall), discharge volume untreated by the treatment works treating domestic sewage, types of human health and environmental impacts of the event, and whether the noncompliance was related to wet weather.

As of December 21, 2020, all reports related to combined sewer overflows, sanitary sewer overflows, or bypass events must be submitted to the Regional Water Board and must be submitted electronically to the initial recipient defined in Standard Provisions – Reporting V.J. The reports shall comply with 40 C.F.R. part 3, 40 C.F.R. section 122.22, and 40 C.F.R. part 127. The Regional Water Board may also require the Permittee to electronically submit reports not related to combined sewer overflows, sanitary sewer overflows, or bypass events under this section. (40 C.F.R. § 122.41(l)(6)(i).)

2. The following shall be included as information that must be reported within 24 hours under this paragraph (40 C.F.R. § 122.41(l)(6)(ii)):

- a. Any unanticipated bypass that exceeds any effluent limitation in this Order. (40 C.F.R. § 122.41(l)(6)(ii)(A).)
  - b. Any upset that exceeds any effluent limitation in this Order. (40 C.F.R. § 122.41(l)(6)(ii)(B).)
3. The Regional Water Board may waive the above-required written report under this provision on a case-by-case basis if an oral report has been received within 24 hours. (40 C.F.R. § 122.41(l)(6)(iii).)

**F. Planned Changes**

The Permittee shall give notice to the Regional Water Board as soon as possible of any planned physical alterations or additions to the permitted facility. Notice is required under this provision only when (40 C.F.R. § 122.41(l)(1)):

1. The alteration or addition to a permitted facility may meet one of the criteria for determining whether a facility is a new source in section 122.29(b) (40 C.F.R. § 122.41(l)(1)(i)); or
2. The alteration or addition could significantly change the nature or increase the quantity of pollutants discharged. This notification applies to pollutants that are not subject to effluent limitations in this Order. (40 C.F.R. § 122.41(l)(1)(ii).)
3. The alteration or addition results in a significant change in the Permittee's sludge use or disposal practices, and such alteration, addition, or change may justify the application of permit conditions that are different from or absent in the existing permit, including notification of additional use or disposal sites not reported during the permit application process or not reported pursuant to an approved land application plan. (40 C.F.R. § 122.41(l)(1)(iii).)

**G. Anticipated Noncompliance**

The Permittee shall give advance notice to the Regional Water Board of any planned changes in the permitted facility or activity that may result in noncompliance with this Order's requirements. (40 C.F.R. § 122.41(l)(2).)

**H. Other Noncompliance**

The Permittee shall report all instances of noncompliance not reported under Standard Provisions – Reporting V.C, V.D, and V.E above at the time monitoring reports are submitted. The reports shall contain the information listed in Standard Provision – Reporting V.E above. For noncompliance events related to combined sewer overflows, sanitary sewer overflows, or bypass events, these reports shall contain the information described in Standard Provision – Reporting V.E and the applicable required data in appendix A to 40 C.F.R. part 127. The Regional Water Board may also require the Permittee to electronically submit reports not related to combined sewer overflows, sanitary sewer overflows, or bypass events under this section. (40 C.F.R. § 122.41(l)(7).)

**I. Other Information**

When the Permittee becomes aware that it failed to submit any relevant facts in a permit application, or submitted incorrect information in a permit application or in any report to the

Regional Water Board, State Water Board, or U.S. EPA, the Permittee shall promptly submit such facts or information. (40 C.F.R. § 122.41(l)(8).)

**J. Initial Recipient for Electronic Reporting Data**

The owner, operator, or the duly authorized representative is required to electronically submit NPDES information specified in appendix A to 40 C.F.R. part 127 to the initial recipient defined in 40 C.F.R. section 127.2(b). U.S. EPA will identify and publish the list of initial recipients on its website and in the Federal Register, by state and by NPDES data group [see 40 C.F.R. section 127.2(c)]. U.S. EPA will update and maintain this listing. (40 C.F.R. § 122.41(l)(9).)

**VI. STANDARD PROVISIONS – ENFORCEMENT**

- A.** The Regional Water Board is authorized to enforce the terms of this permit under several provisions of the Water Code, including, but not limited to, sections 13385, 13386, and 13387.

**VII. ADDITIONAL PROVISIONS – NOTIFICATION LEVELS**

**A. Publicly-Owned Treatment Works (POTWs)**

All POTWs shall provide adequate notice to the Regional Water Board of the following (40 C.F.R. § 122.42(b)):

- 1.** Any new introduction of pollutants into the POTW from an indirect discharger that would be subject to sections 301 or 306 of the CWA if it were directly discharging those pollutants (40 C.F.R. § 122.42(b)(1)); and
- 2.** Any substantial change in the volume or character of pollutants being introduced into that POTW by a source introducing pollutants into the POTW at the time of adoption of this Order (40 C.F.R. § 122.42(b)(2)).
- 3.** Adequate notice shall include information on the quality and quantity of effluent introduced into the POTW as well as any anticipated impact of the change on the quantity or quality of effluent to be discharged from the POTW. (40 C.F.R. § 122.42(b)(3)).



**ATTACHMENT E – MONITORING AND REPORTING PROGRAM**

**Contents**

I. General Monitoring Provisions..... E-2

II. Monitoring Locations ..... E-3

III. Influent Monitoring Requirements..... E-4

    A. Monitoring Location INF-001 ..... E-4

IV. Effluent Monitoring Requirements..... E-4

    A. Monitoring Locations EFF-001 and EFF-003 ..... E-4

V. Whole Effluent Toxicity Testing Requirements..... E-6

    A. Acute Toxicity Testing ..... E-6

    B. Chronic Toxicity Testing ..... E-8

    C. Toxicity Reduction Evaluation (TRE) Process ..... E-12

VI. Land Discharge Monitoring Requirements – not applicable..... E-13

VII. Recycling Monitoring Requirements – Not Applicable..... E-13

VIII. Receiving Water Monitoring Requirements – Surface Water and Groundwater ..... E-13

    A. Monitoring Location RSW-001 and RSW-003 ..... E-13

    B. Monitoring Location RSW-002 and RSW-004 ..... E-14

    C. Groundwater Monitoring – Not Required ..... E-14

IX. Other Monitoring Requirements ..... E-14

    A. Monitoring Location INT-001 ..... E-14

    B. Visual Monitoring (Monitoring Locations RSW-001 and RSW-002)..... E-15

    C. Sludge Monitoring (Monitoring Location BIO-001) ..... E-15

X. Reporting Requirements..... E-15

    A. General Monitoring and Reporting Requirements ..... E-15

    B. Self-Monitoring Reports (SMRs)..... E-15

    C. Discharge Monitoring Reports (DMRs) ..... E-18

    D. Other Reports ..... E-18

    E. Spill Notification..... E-21

**Tables**

Table E-1 Monitoring Station Locations ..... E-3

Table E-2 Influent Monitoring – Monitoring Location INF-001 ..... E-4

Table E-3 Effluent Monitoring – Monitoring Locations EFF-001 and EFF-003..... E-4

Table E-4. Receiving Water Monitoring – Monitoring Location RSW-001 and RSW-003..... E-13

Table E-5. Receiving Water Monitoring – Monitoring Location RSW-002 ..... E-14

Table E-6. Internal Effluent Monitoring – Monitoring Location INT-001 ..... E-15

Table E-7. Monitoring Periods and Reporting Schedule<sup>1</sup> ..... E-16

Table E-8. Reporting Requirements for Special Provisions Reports ..... E-18

## ATTACHMENT E – MONITORING AND REPORTING PROGRAM (MRP)

The Code of Federal Regulations (40 C.F.R. § 122.48) requires that all NPDES permits specify monitoring and reporting requirements. California Water Code section 13383 also authorizes the Regional Water Board to require technical and monitoring reports. This MRP establishes monitoring and reporting requirements that implement federal and California regulations.

### I. GENERAL MONITORING PROVISIONS

- A. Wastewater Monitoring Provision.** Composite samples may be taken by a proportional sampling device approved by the Executive Officer or by grab samples composited in proportion to flow. In compositing grab samples, the sampling interval shall not exceed 1 hour.
- B. Supplemental Monitoring Provision.** If the Permittee monitors any pollutant more frequently than required by this Order, using test procedures approved by 40 C.F.R. part 136 or as specified in this Order, the results of such monitoring shall be included in the calculation and reporting of the data submitted in the monthly and annual discharge monitoring reports.
- C. Laboratory Certification.** Laboratories analyzing monitoring samples shall be certified by the State Water Resources Control Board (State Water Board), Division of Drinking Water (DDW) in accordance with the provisions of Water Code section 13176, and must include quality assurance / quality control data with their analytical reports.
- D. Instrumentation and Calibration Provision.** All monitoring instruments and devices used by the Permittee to fulfill the prescribed monitoring program shall be properly maintained and calibrated as necessary to ensure their continued accuracy. All flow measurement devices shall be calibrated no less than the manufacturer's recommended intervals or one year intervals, (whichever comes first) to ensure continued accuracy of the devices.
- E. Minimum Levels (ML) and Reporting Levels (RL).** Unless otherwise specified by this MRP, all monitoring shall be conducted according to test procedures established at 40 C.F.R. 136, *Guidelines Establishing Test Procedures for Analysis of Pollutants*. All analyses shall be conducted using the lowest practical quantitation limit achievable using U.S. EPA approved methods. For the purposes of the NPDES program, when more than one test procedure is approved under 40 C.F.R., part 136 for the analysis of a pollutant or pollutant parameter, the test procedure must be sufficiently sensitive as defined at 40 C.F.R. 122.21(e)(3) and 122.44(i)(1)(iv). Where effluent limitations are set below the lowest achievable quantitation limits, pollutants not detected at the lowest practical quantitation limits will be considered in compliance with effluent limitations. Analysis for toxics listed by the California Toxics Rule (CTR) shall also adhere to guidance and requirements contained in the *Policy for Implementation of Toxics Standards for Inland Surface Waters, Enclosed Bays, and Estuaries of California* (2005) (SIP). However, there may be situations when analytical methods are published with MLs that are more sensitive than the MLs for analytical methods listed in the SIP. For instance, U.S. EPA Method 1631E for mercury is not currently listed in SIP Appendix 4, but it is published with an ML of 0.5 ng/L that makes it a sufficiently sensitive analytical method. Similarly, U.S. EPA Method 245.7 for mercury is published with an ML of 5 ng/L.
- F. Discharge Monitoring Report Quality Assurance (DMR-QA) Study.** The Permittee shall ensure that the results of the DMR-QA Study or the most recent Water Pollution Performance

Evaluation Study are submitted annually, by March 1, to the State Water Board at the following address:

State Water Resources Control Board  
 Quality Assurance Program Officer  
 Office of Information Management and Analysis  
 1001 I Street, Sacramento, CA 95814

**II. MONITORING LOCATIONS**

The Permittee shall establish the following monitoring locations to demonstrate compliance with the effluent limitations, discharge specifications, and other requirements in this Order:

**Table E-1 Monitoring Station Locations**

<b>Discharge Point Name</b>	<b>Monitoring Location Name</b>	<b>Monitoring Location Description</b>
--	INF-001	Influent at the headworks of the wastewater treatment facility (WWTF) prior to treatment.
--	INT-001	Location for monitoring the effluent from the chlorine contact chamber prior to dechlorination for purposes of measuring chlorine residual.
001	EFF-001	Treated effluent downstream of the dechlorination facilities and before the effluent comes in contact with the receiving water.
002 (Historic)	EFF-002 (Historic)	Treated effluent from high flow storage ponds that were blended with 001 effluent. Discharges at Discharge Point 002 are not authorized by this Order and are shown here for information purposes only.
003	EFF-003	Treated effluent downstream of the disinfection facilities and before effluent enters the percolation ponds.
--	RSW-001	A location in Strongs Creek, surface water that is upstream of the influence of the discharge.
--	RSW-002	A location in Strongs Creek, surface water that is at the point of discharge or other location approved by the Executive Officer.
	RSW-003	A location in the Eel River, surface water that is upstream of the influence of the discharge and Strongs Creek.
	RSW-004	A location in the Eel River, surface water that is at the point of discharge point 001 or 003 or other location approved by the Executive Officer.
--	BIO-001	A representative sample of the sludge or biosolids generated when removed for disposal.

**III. INFLUENT MONITORING REQUIREMENTS**

**A. Monitoring Location INF-001**

1. The Permittee shall monitor influent to the Facility at Monitoring Location INF-001 as follows:

**Table E-2 Influent Monitoring – Monitoring Location INF-001**

Parameter	Units	Sample Type	Minimum Sampling Frequency	Required Analytical Test Method <sup>1</sup>
Influent Flow <sup>2</sup>	mgd	Meter	Daily	--
Biochemical Oxygen Demand 5-day @ 20°C (BOD <sub>5</sub> )	mg/L	24-hr Composite	Weekly	Standard Methods
Total Suspended Solids (TSS)	mg/L	24-hr Composite	Weekly	Standard Methods

**Table Notes:**

1. In accordance with the current edition of *Standard Methods for Examination of Water and Wastewater* (American Public Health Administration) or current test procedures specified in 40 C.F.R. part 136.
2. Each month, the Permittee shall report the daily average and monthly average flows.

**IV. EFFLUENT MONITORING REQUIREMENTS**

**A. Monitoring Locations EFF-001 and EFF-003**

1. The Permittee shall monitor effluent to be discharged to Strongs Creek at Monitoring Location EFF-001 and the Eel River at Monitoring Location EFF-003 as follows:

**Table E-3 Effluent Monitoring – Monitoring Locations EFF-001 and EFF-003**

Parameter	Units	Sample Type	Minimum Sampling Frequency	Required Analytical Test Method <sup>1</sup>
Effluent Flow <sup>2</sup>	mgd	Meter	Continuous	--
Dilution Rate	% of stream flow	Calculation	Daily	--
Biochemical Oxygen Demand 5-day @ 20°C (BOD <sub>5</sub> )	mg/L	24-hr Composite	Weekly <sup>3</sup>	Standard Methods <sup>3</sup>
Total Suspended Solids (TSS)	mg/L	24-hr Composite	Weekly <sup>3</sup>	Standard Methods
pH	s.u.	Grab	Weekly <sup>3,4</sup>	Standard Methods
Settleable Solids	mL/L	Grab	Weekly <sup>3</sup>	Standard Methods
Chlorine, Total Residual	mg/L	Grab/Meter	Daily/Continuous <sup>5,13</sup>	Standard Methods
Temperature	°C	Grab	Weekly <sup>3,4</sup>	Standard Methods
Total Coliform Bacteria	MPN/100 mL	Grab	Weekly <sup>3</sup>	Standard Methods
Chlorodibromomethane	µg/L	Grab	Monthly <sup>6</sup>	GC (ML 0.5 µg/L) <sup>7</sup>
Dichlorobromomethane	µg/L	Grab	Monthly <sup>6</sup>	GC (ML 0.5 µg/L) <sup>7</sup>
Heptachlor Epoxide	µg/L	Grab	Monthly <sup>6,14</sup>	GC (ML 0.01 µg/L) <sup>7</sup>
Ammonia Nitrogen, Total (as N)	mg/L	Grab	Monthly <sup>6</sup>	Standard Methods

Parameter	Units	Sample Type	Minimum Sampling Frequency	Required Analytical Test Method <sup>1</sup>
Ammonia Nitrogen, Unionized	mg/L	Calculation	Monthly	Standard Methods
Nitrate Nitrogen, Total (as N)	mg/L	Grab	Monthly <sup>6</sup>	Standard Methods
Phosphorus, Total (as P)	mg/L	Grab	Monthly	Standard Methods
Aluminum <sup>8</sup>	mg/L	Grab	Twice per permit term	Standard Methods
CTR Priority Pollutants <sup>9</sup>	µg/L	24-hr Composite <sup>10</sup>	Twice per permit term	Standard Methods <sup>11</sup>
Acute Toxicity <sup>12</sup>	% Survival, Pass or Fail, and % Effect	24-hr Composite	Quarterly	See Section V below
Chronic Toxicity <sup>12</sup>	Pass or Fail, and % Effect	24-hr Composite	Annually	See Section V below

**Table Notes:**

- In accordance with the current edition of *Standard Methods for Examination of Water and Wastewater* (American Public Health Administration) or current test procedures specified in 40 C.F.R. part 136.
- The Permittee shall report the daily average and monthly average flows.
- Accelerated Monitoring (weekly monitoring frequency). If two consecutive weekly test results exceed an effluent limitation, the Permittee shall take two samples each of the two weeks following receipt of the second sample result. During the intervening period, the Permittee shall take steps to identify the cause of the exceedance and take steps to return to compliance.
- pH and temperature monitoring must coincide with monthly monitoring for ammonia.
- Accelerated Monitoring (daily monitoring frequency). If a test result exceeds an effluent limitation, the Permittee shall increase monitoring frequency to a minimum of twice a day for a week to evaluate whether the exceedance is persisting. If two or more samples in a week exceed an effluent limitation, the Permittee shall take steps to identify the cause of the exceedance and take steps needed to return to compliance.
- Accelerated Monitoring (monthly monitoring frequency). If a test result exceeds an effluent limitation the Permittee shall take two more samples, one within 14 days and one within 21 days following receipt of the initial sample result. During the intervening period, the Permittee shall take steps to identify the cause of the exceedance and take steps needed to return to compliance.
- GC = Gas Chromatography
- Aluminum sampling shall be concurrent with CTR Priority Pollutant sampling event.
- Those pollutants identified by the California Toxics Rule at 40 C.F.R. section 131.38. The Permittee is not required to sample and analyze for asbestos. Hardness shall be monitored concurrently with the priority pollutant sample
- CTR pollutant samples shall be collected using 24-hour composite sampling, except for pollutants that are volatile. Samples for volatile pollutants may be collected as grab samples
- Analytical methods must achieve the lowest minimum level (ML) specified in Appendix 4 of the SIP and, in accordance with section 2.4 of the SIP, the Permittee shall report the ML and MDL for each sample result.
- Whole effluent acute and chronic toxicity shall be monitored in accordance with the requirements of section V of this Monitoring and Reporting Program.
- Prior to May 1, 2019, a minimum of daily grab samples are required, and the Permittee shall report the maximum daily chlorine residual. By May 1, 2019, the Permittee shall monitor continuously to demonstrate that the discharge has been adequately dechlorinated to achieve chlorine residual effluent limitations specified in section IV.A.1.a, Table 4, at all times. The Permittee shall report from discrete readings of the continuous monitoring every hour on the hour and report the average of the hourly readings on a daily basis in accordance with Compliance Determination section VII.M of this Order. The Permittee shall calibrate chlorine residual analyzers against grab samples as frequently as necessary to maintain accurate and reliable operation.
- Monitoring may be reduced to annually if the Permittee complies with the effluent limitation, as stated in Order section IV.A.1.a, for 24 consecutive months.

## V. WHOLE EFFLUENT TOXICITY TESTING REQUIREMENTS

### A. Acute Toxicity Testing

The Permittee shall conduct acute whole effluent toxicity testing (WET) in accordance with the following acute toxicity testing requirements.

1. **Test Frequency.** The Permittee shall conduct acute WET testing in accordance with the schedule established by this MRP while discharging at Discharge Point 001, as summarized in Table E-4, above.
2. **Discharge In-stream Waste Concentration (IWC) for Acute Toxicity.** The IWC for this discharge is 100 percent effluent.<sup>1</sup>
3. **Sample Volume and Holding Time.** The total sample volume shall be determined by the specific toxicity test method used. Sufficient sample volume shall be collected to perform the required toxicity test. All toxicity tests shall be conducted as soon as possible following sample collection. No more than 36 hours shall elapse before the conclusion of sample collection and test initiation.
4. **Freshwater Test Species and Test Methods.** The Permittee shall conduct the following acute toxicity tests in accordance with species and test methods in *Methods for Measuring the Acute Toxicity of Effluents and Receiving Waters to Freshwater and Marine Organisms* (U.S. EPA Report No. EPA-821-R-02-012, 5th edition or subsequent editions). In no case shall these species be substituted with another test species unless written authorization from the Executive Officer is received.
  - a. A 96-hour static renewal toxicity test with an invertebrate, the water flea, *Ceriodaphnia dubia* (Survival Test Method 2002.0).
  - b. A 96-hour static renewal toxicity test with a vertebrate, the rainbow trout, *Oncorhynchus mykiss* (Survival Test Method 2019.0).
5. **Species Sensitivity Screening.** Species sensitivity screening shall be conducted during this permit's first required sample collection. The Permittee shall collect a single effluent sample and concurrently conduct two acute toxicity tests using the invertebrate and fish species identified in section V.A.4, above. This sample shall also be analyzed for the parameters required for the discharge. The species that exhibits the highest "Percent (%) Effect" at the discharge IWC during species sensitivity screening shall be used for routine acute toxicity monitoring during the permit term.
6. **Quality Assurance and Additional Requirements.** Quality assurance measures, instructions, and other recommendations and requirements are found in the test methods manual referenced in section V.A.4, above. Additional requirements are specified below.
  - a. The discharge is subject to determination of "Pass" or "Fail" and "Percent (%) Effect" from acute toxicity tests using the Test of Significant Toxicity (TST) approach described in *National Pollutant Discharge Elimination System Test of Significant Toxicity Implementation Document* (EPA 833-R10-003, 2010), Appendix A, Figure A-1, and Table A-1. The null hypothesis ( $H_0$ ) for the TST approach is: Mean discharge IWC response  $0.80 \times$  Mean control response. A test result that rejects this null hypothesis is

---

<sup>1</sup> The acute toxicity test shall be conducted using 100 percent effluent collected at Monitoring Location EFF-001.



- b. The toxicity test results for the TST approach, reported as “Pass” or “Fail” and “Percent (%) Effect” at the acute toxicity IWC for the discharge.
- c. Water quality measurements for each toxicity test (e.g., pH, dissolved oxygen, temperature, conductivity, hardness, salinity, chlorine, ammonia).
- d. TRE/TIE results. The Executive Officer shall be notified no later than 30 days from completion of each aspect of TRE/TIE analyses.
- e. Statistical program (e.g., TST calculator, CETIS, etc.) output results for each toxicity test.

## B. Chronic Toxicity Testing

The Permittee shall conduct chronic toxicity testing in accordance with the following chronic toxicity testing requirements:

1. **Test Frequency.** The Permittee shall conduct chronic toxicity testing in accordance with the schedule established by this MRP while discharging at Discharge Point 001, as summarized in Table E-4, above.
2. **Discharge In-stream Waste Concentration (IWC) for Chronic Toxicity.** The chronic toxicity IWC for this discharge is 100 percent effluent.<sup>2</sup>
3. **Sample Volume and Holding Time.** The total sample volume shall be determined by the specific toxicity test method used. Sufficient sample volume shall be collected to perform the required toxicity test. All toxicity tests shall be conducted as soon as possible following sample collection. For toxicity tests requiring renewals, a minimum of three 24-hour composite samples shall be collected. The lapsed time (holding time) from sample collection to first use of each sample must not exceed 36 hours.
4. **Freshwater Test Species and Test Methods.** The Permittee shall conduct the following chronic toxicity tests in accordance with species and test methods in *Short-Term Methods for Estimating the Chronic Toxicity of Effluents and Receiving Water to Freshwater Organisms* (U.S. EPA Report No. EPA-821-R-02-013, or subsequent editions). In no case shall these species be substituted with another test species unless written authorization from the Executive Officer is received.
  - a. A 7-day static renewal toxicity test with a vertebrate, the fathead minnow, *Pimephales promelas* (Larval Survival and Growth Test Method 1000.0).
  - b. A 96-hour static renewal toxicity test with an invertebrate, the water flea, *Ceriodaphnia dubia* (Survival and Reproduction Test Method 1002.0).
  - c. A 96-hour static non-renewal toxicity test with a plant, the green algae, *Selenastrum capricornutum* (also named *Raphidocelis subcapitata*) (Growth Test Method 1003.0).
5. **Species Sensitivity Screening.** Species sensitivity screening shall be conducted during this permit’s first required sample collection. The Permittee shall collect a single effluent sample and concurrently conduct three chronic toxicity tests using the fish, the invertebrate, and the algae species identified in section V.B.4, above. This sample shall also be analyzed for the parameters required for the discharge. The species that exhibits the highest “Percent

---

<sup>2</sup> The chronic toxicity test shall be conducted using a series of five dilutions and a control. The series shall consist of the following dilutions: 12.5, 25, 50, 75, and 100 percent. Compliance determination will be based on the IWC (100 percent effluent) and a control as further described in Fact Sheet section IV.C.5.c.



(%) Effect” at the discharge IWC during species sensitivity screening shall be used for routine monitoring during the permit term.

- 6. Quality Assurance and Additional Requirements.** Quality assurance measures, instructions, and other recommendations and requirements are found in the test methods manual previously referenced. Additional requirements are specified below.
- a.** The discharge is subject to determination of “Pass” or “Fail” and “Percent (%) Effect” for chronic toxicity tests using the TST approach described in *National Pollutant Discharge Elimination System Test of Significant Toxicity Implementation Document* (EPA 833-R10-003, 2010), Appendix A, Figure A-1, and Table A-1. The null hypothesis ( $H_0$ ) for the TST approach is: Mean discharge IWC response  $0.75 \times$  Mean control response. A test result that rejects this null hypothesis is reported as “Pass”. A test result that does not reject this null hypothesis is reported as “Fail”. The relative “Percent (%) Effect” at the discharge IWC is defined and reported as:  $((\text{Mean control response} - \text{Mean discharge IWC response}) \div \text{Mean control response}) \times 100$ .
  - b.** If the effluent toxicity test does not meet the minimum effluent or reference toxicant TAC specified in the referenced test method, then the Permittee shall re-sample and re-test within 14 days.
  - c.** Dilution water and control water shall be laboratory water prepared and used as specified in the test methods manual. If dilution water and control water is different from test organism culture water, then a second control using culture water shall also be used.
  - d.** Monthly reference toxicant testing is sufficient. All reference toxicant test results should be reviewed and reported.
  - e.** The Permittee shall perform toxicity tests on final effluent samples. Chlorine and ammonia shall not be removed from the effluent sample prior to toxicity testing, unless explicitly authorized under this section of the MRP and the rationale is explained in the Fact Sheet (Attachment F).
  - f. Ammonia Removal.** Except with prior approval from the Executive Officer of the Regional Water Board, ammonia shall not be removed from bioassay samples. The Permittee must demonstrate the effluent toxicity is caused by ammonia because of increasing test pH when conducting the toxicity test. It is important to distinguish the potential toxic effects of ammonia from other pH sensitive chemicals, such as certain heavy metals, sulfide, and cyanide. The following may be steps to demonstrate that the toxicity is caused by ammonia and not other toxicants before the Executive Officer would allow for control of pH in the test.
    - i.** There is consistent toxicity in the effluent and the maximum pH in the toxicity test is in the range to cause toxicity due to increased pH.
    - ii.** Chronic ammonia concentrations in the effluent are greater than 4 mg/L total ammonia.
    - iii.** Conduct graduated pH tests as specified in the toxicity identification evaluation methods. For example, mortality should be higher at pH 8 and lower at pH 6.

- iv. Treat the effluent with a zeolite column to remove ammonia. Mortality in the zeolite treated effluent should be lower than the non-zeolite treated effluent. Then add ammonia back to the zeolite-treated samples to confirm toxicity due to ammonia.

When it has been demonstrated that toxicity is due to ammonia because of increasing test pH, pH may be controlled using appropriate procedures which do not significantly alter the nature of the effluent.

- 7. **Notification.** The Permittee shall notify the Regional Water Board verbally within 72 hours and in writing within 14 days after the receipt of a result of "Fail" during routine or accelerated monitoring.
- 8. **Accelerated Monitoring Requirements.** Accelerated monitoring for chronic toxicity is triggered when a chronic toxicity test, analyzed using the TST approach, results in "Fail" and the "Percent Effect" is  $\geq 0.50$ . Within 24 hours of the time the Permittee becomes aware of a summary result of "Fail", the Permittee shall implement an accelerated monitoring schedule consisting of four toxicity tests—consisting of 5-effluent concentrations (including the discharge IWC) and a control—conducted at approximately 2 week intervals, over an 8 week period. If each of the accelerated toxicity tests results is "Pass", the Permittee shall return to routine monitoring for the next monitoring period. If one of the accelerated toxicity tests results is "Fail", the Permittee shall immediately implement the TRE Process conditions set forth in section V.C, below.

## 9. Reporting

- a. **Routine Reporting.** Chronic toxicity monitoring results shall be submitted with the monthly SMR for the month that chronic toxicity monitoring was performed. Routine reporting shall include the following in order to demonstrate compliance with permit requirements:
  - i. WET test reports shall include the contracting laboratory's complete report provided to the Permittee and shall be in accordance with the appropriate "Report Preparation and Test Review" sections of the methods manual and this MRP. The WET test reports shall contain a narrative report that includes details about WET test procedures and results, including the following:
    - (a) Receipt and handling of the effluent sample that includes a tabular summary of initial water quality characteristics (e.g., pH, dissolved oxygen, temperature, conductivity, hardness, salinity, chlorine, ammonia);
    - (b) The source and make-up of the lab control/diluent water used for the test;
    - (c) Any manipulations done to lab control/diluent and effluent such as filtration, nutrient addition, etc.;
    - (d) Tabular summary of test results for control water and each effluent dilution and statistics summary to include calculation of the NOEC, TUC, and IC25;
    - (e) Identification of any anomalies or nuances in the test procedures or results;
    - (f) WET test results shall include, at a minimum, for each test:
      - (1) Sample date(s);

- (2) Test initiation date;
  - (3) Test species;
  - (4) Determination of “Pass” or “Fail” and “Percent Effect” following the Test of Significant Toxicity hypothesis testing approach in *National Pollutant Discharge Elimination System Test of Significant Toxicity Implementation Document* (EPA 833-R-10-003, 2010). The “Percent Effect” shall be calculated as follows:  
$$\text{“Percent Effect” (or Effect, in \%)} = ((\text{Control mean response} - \text{IWC mean response}) \div \text{Control mean response}) \times 100$$
  - (5) End point values for each dilution (e.g., number of young, growth rate, percent survival);
  - (6) NOEC value(s) in percent effluent;
  - (7) IC15, IC25, IC40, and IC50 values (or EC15, EC25...etc.) in percent effluent;
  - (8) TUC values (100/NOEC);
  - (9) Mean percent mortality ( $\pm$ s.d.) after 96 hours in 100 percent effluent (if applicable);
  - (10) NOEC and LOEC values for reference toxicant test(s);
  - (11) IC50 or EC50 value(s) for reference toxicant test(s);
  - (12) Available water quality measurements for each test (e.g., pH, DO, temperature, conductivity, hardness, salinity, ammonia);
  - (13) Statistical methods used to calculate endpoints;
  - (14) The statistical program (e.g., TST calculator, CETIS, etc.) output results, which includes the calculation of percent minimum significant difference (PMSD); and
  - (15) Results of applicable reference toxicant data with the statistical output page identifying the species, NOEC, LOEC, type of toxicant, dilution water used, concentrations used, PMSD and dates tested; the reference toxicant control charts for each endpoint, to include summaries of reference toxicant tests performed by the contracting laboratory; and any information on deviations from standard test procedures or problems encountered in completing the test and how the problems were resolved.
- ii. **Compliance Summary.** In addition to the WET report, the Permittee shall submit a compliance summary that includes an updated chronology of chronic toxicity test results expressed in “Pass”/“Fail”, NOEC and TUC for tests conducted during the permit term, and organized by test species, type of test (survival, growth or reproduction), and monitoring frequency (routine, accelerated, or TRE). Each compliance summary report shall clearly identify whether or not the effluent discharge is below the chronic toxicity monitoring triggers and, in the event that

the effluent discharge exceeds a single sample or median chronic toxicity trigger, the status of efforts (e.g., accelerated monitoring, TRE, TIE, etc.) to identify the source of chronic toxicity as required by section V.B.8 of this MRP.

- b. TRE/TIE results. The Executive Officer shall be notified no later than 30 days from completion of each aspect of TRE/TIE analyses.

### C. Toxicity Reduction Evaluation (TRE) Process

1. **TRE Work Plan.** The Permittee submitted a TRE Work Plan to the Regional Water Board by **January 26, 2009**. The Permittee's TRE Work Plan shall be reviewed and updated as necessary in order to remain current and applicable to the discharge and discharge facilities.

The Permittee shall notify the Regional Water Board of this review and submit any revisions of the TRE Work Plan within 90 days of the notification, to be ready to respond to toxicity events. The TRE Work Plan shall describe the steps the Permittee intends to follow if toxicity is detected, and should include at least the following items:

- a. A description of the investigation and evaluation techniques that would be used to identify potential causes and sources of toxicity, effluent variability, and treatment system efficiency.
  - b. A description of the facility's methods of maximizing in-house treatment efficiency, good housekeeping practices, and a list of all chemicals used in the operation of this Facility.
  - c. If a toxicity identification evaluation (TIE) is necessary, an indication of the person who would conduct the TIEs (i.e., an in-house expert or an outside contractor).
2. **Preparation and Implementation of a Detailed TRE Work Plan.** If one of the accelerated toxicity tests described in section V.A.8, above, does not comply with the three sample median minimum limitation (90 percent survival) or in section V.B.8, above, results in "Fail", the Permittee shall immediately initiate a TRE using, according to the type of treatment facility, EPA manual *Generalized Methodology for Conducting Industrial Toxicity Reduction Evaluations* (EPA/600/2-88/070, 1989) and within 30 days submit of receipt of the accelerated monitoring result to the Regional Water Board Executive Officer a Detailed TRE Work Plan, which shall follow the generic TRE Work Plan revised as appropriate for the toxicity event described in section V.A.8 or V.B.8 of this MRP. The Detailed TRE Work Plan shall include the following information, and comply with additional conditions set by the Regional Water Board Executive Officer:
    - a. Further actions by the Permittee to investigate, identify, and correct causes of toxicity.
    - b. Actions the Permittee will take to mitigate effects of the discharge and prevent the recurrence of toxicity.
    - c. A schedule for these actions, progress reports, and the final report.
  3. **TIE Implementation.** The Permittee may initiate a TIE as part of a TRE to identify the causes of toxicity using the same species and test methods and, as guidance, EPA manuals: *Methods for Aquatic Toxicity Identification Evaluations: Phase I Toxicity Characterization Procedures* (EPA/600/6-91/003, 1991); *Methods for Aquatic Toxicity Identification Evaluations, Phase II Toxicity Identification Procedures for Samples Exhibiting Acute and*

*Chronic Toxicity* (EPA/600/R-92/080, 1993); *Methods for Aquatic Toxicity Identification Evaluations, Phase III Toxicity Confirmation Procedures for Samples Exhibiting Acute and Chronic Toxicity* (EPA/600/R-92/081, 1993); and *Marine Toxicity Identification Evaluation (TIE): Phase I Guidance Document* (EPA/600/R-96-054, 1996). The TIE should be conducted on the species demonstrating the most sensitive toxicity response.

4. Many recommended TRE elements parallel required or recommended efforts for source control, pollution prevention, and storm water control programs. TRE efforts should be coordinated with such efforts. As toxic substances are identified or characterized, the Permittee shall continue the TRE by determining the sources and evaluating alternative strategies for reducing or eliminating the substances from the discharge. All reasonable steps shall be taken to reduce toxicity to levels consistent with toxicity evaluation parameters.
5. The Permittee shall conduct routine effluent monitoring for the duration of the TRE process. Additional accelerated monitoring and TRE work plans are not required once a TRE has begun.
6. The Regional Water Board recognizes that toxicity may be episodic and identification of the causes and reduction of sources of toxicity may not be successful in all cases. The TRE may be ended at any stage if monitoring finds there is no longer toxicity.

**VI. LAND DISCHARGE MONITORING REQUIREMENTS – NOT APPLICABLE**

This Order does not authorize discharges to land.

**VII. RECYCLING MONITORING REQUIREMENTS – NOT APPLICABLE**

This Order does not authorize discharges of recycled water.

**VIII. RECEIVING WATER MONITORING REQUIREMENTS – SURFACE WATER AND GROUNDWATER**

**A. Monitoring Location RSW-001 and RSW-003**

1. The Permittee shall monitor Strongs Creek at Monitoring Location RSW-001 and the Eel River at Monitoring Location RSW-003 during periods of discharge as follows:

**Table E-4. Receiving Water Monitoring – Monitoring Location RSW-001 and RSW-003**

Parameter	Units	Sample Type	Minimum Sampling Frequency	Required Analytical Test Method
Flow <sup>1</sup>	Mgd	Meter	Daily	--
pH	s.u.	Grab	Monthly <sup>2</sup>	Standard Methods <sup>3</sup>
Hardness, Total (as CaCO <sub>3</sub> )	mg/L	Grab	Monthly	Standard Methods
Aluminum <sup>4</sup>	mg/L	Grab	Twice per permit term	Standard Methods
Temperature	°C	Grab	Monthly <sup>2</sup>	Standard Methods
Turbidity	NTU	Grab	Monthly	Standard Methods
Dissolved Oxygen	mg/L	Grab	Monthly	Standard Methods
Electrical Conductivity @ 25°C	µmhos/cm	Grab	Monthly	Standard Methods
Total Dissolved Solids	mg/L	Grab	Monthly	Standard Methods

Parameter	Units	Sample Type	Minimum Sampling Frequency	Required Analytical Test Method
CTR Priority Pollutants <sup>5</sup>	µg/L	Grab	Twice per permit term	Standard Methods <sup>5</sup>
<b>Table Notes:</b> 1. The flow rate shall be determined using the sum of the flows at United States Geological Survey (USGS) gauge in the Eel River near Scotia and USGS Gauge No. 11478500 in the Van Duzen River near Bridgeville. 2. pH and temperature monitoring must coincide with monthly effluent monitoring for ammonia. 3. In accordance with the current edition of <i>Standard Methods for Examination of Water and Wastewater</i> (American Public Health Administration) or current test procedures specified in 40 C.F.R. part 136. 4. See Table Note 8 in Table E-4. 5. Those pollutants identified by the California Toxics Rule at 40 C.F.R. section 131.38. The Permittee is not required to sample and analyze for asbestos. Hardness shall be monitored concurrently with the priority pollutant sample. Monitoring shall occur simultaneously with effluent monitoring for CTR priority pollutants required by section IV.A of this MRP. 6. Analytical methods must achieve the lowest minimum level (ML) specified in Appendix 4 of the SIP and, in accordance with section 2.4 of the SIP, the Permittee shall report the ML and MDL for each sample result.				

**B. Monitoring Location RSW-002 and RSW-004**

- The Permittee shall monitor Strongs Creek at Monitoring Location RSW-002 and the Eel River at Monitoring Location RSW-003 during periods of discharge as follows:

**Table E-5. Receiving Water Monitoring – Monitoring Location RSW-002**

Parameter	Units	Sample Type	Minimum Sampling Frequency	Required Analytical Test Method
pH	s.u.	Grab	Monthly <sup>1</sup>	Standard Methods <sup>2</sup>
Temperature	°C	Grab	Monthly <sup>1</sup>	Standard Methods
Turbidity	NTU	Grab	Monthly	Standard Methods
Aluminum <sup>3</sup>	mg/L	Grab	Twice per permit term	Standard Methods
Dissolved Oxygen	mg/L	Grab	Monthly	Standard Methods
Electrical Conductivity @ 25°C	µmhos/cm	Grab	Monthly	Standard Methods
Total Dissolved Solids	mg/L	Grab	Monthly	Standard Methods
Floatables/dicoloration	--	Visual	Monthly	--
<b>Table Notes:</b> 1. pH and temperature monitoring must coincide with monthly effluent monitoring for ammonia. 2. In accordance with the current edition of <i>Standard Methods for Examination of Water and Wastewater</i> (American Public Health Administration) or current test procedures specified in 40 C.F.R. part 136. 3. See Table Note 8 in Table E-4.				

**C. Groundwater Monitoring – Not Required**

This Order does not require groundwater monitoring at this time.

**IX. OTHER MONITORING REQUIREMENTS**

**A. Monitoring Location INT-001**

- The Permittee shall monitor the discharge from the chlorine contact chamber prior to dechlorination at Monitoring Location INT-001 as follows:

**Table E-6. Internal Effluent Monitoring – Monitoring Location INT-001**

Parameter	Units	Sample Type	Minimum Sampling Frequency	Required Analytical Test Method
Chlorine, Total Residual <sup>2</sup>	mg/L	Grab/Meter	Daily/Continuous	Standard Methods <sup>1</sup>
<p><u>Table Notes:</u></p> <ol style="list-style-type: none"> <li>1. In accordance with the current edition of <i>Standard Methods for Examination of Water and Wastewater</i> (American Public Health Administration) or current test procedures specified in 40 C.F.R. part 136.</li> <li>2. Prior to May 1, 2019, a minimum of daily grab samples are required, and the Permittee shall report the maximum daily chlorine residual. By October 1, 2017, the Permittee shall monitor continuously to demonstrate that the appropriate chlorine residual concentration is maintained in the effluent at INT-001 at all times. At a minimum, the Permittee shall record readings of the continuous monitoring every hour on the hour and report the maximum recorded daily chlorine residual. The Permittee shall calibrate chlorine residual analyzers against grab samples as frequently as necessary to maintain accurate and reliable operation.</li> </ol>				

**B. Visual Monitoring (Monitoring Locations RSW-001 and RSW-002)**

1. Visual observations of the receiving water shall be recorded monthly and on the first day of each intermittent discharge. Visual monitoring shall include, but not be limited to, observations for floating materials, coloration, objectionable aquatic growths, oil and grease films, and odors. Visual observations shall be recorded and included in the Permittee’s monthly SMRs.

**C. Sludge Monitoring (Monitoring Location BIO-001)**

1. Sludge sampling shall be conducted according to the requirements specified by the location and type of disposal activities undertaken.
2. Sampling records shall be retained for a minimum of 5 years. A log shall be maintained for sludge quantities generated and of handling and disposal activities. The frequency of entries is discretionary, however, the log must be complete enough to serve as a basis for developing the Sludge Handling and Disposal report that is required as part of the Annual Report.

**X. REPORTING REQUIREMENTS**

**A. General Monitoring and Reporting Requirements**

1. The Permittee shall comply with all Standard Provisions (Attachment D) related to monitoring, reporting, and recordkeeping.

**B. Self-Monitoring Reports (SMRs)**

1. The Permittee shall submit electronic Self-Monitoring Reports (eSMRs) using the State Water Board’s California Integrated Water Quality System (CIWQS) Program Web site (<http://www.waterboards.ca.gov/ciwqs/index.html>). The CIWQS Web site will provide additional directions for SMR submittal in the event there will be service interruption for electronic submittal. The Permittee shall maintain sufficient staffing and resources to ensure it submits eSMRs that are complete and timely. This includes provision of training and supervision of individuals (e.g., Permittee personnel or consultant) on how to prepare and submit eSMRs.

2. The Permittee shall report in the SMR the results for all monitoring specified in this MRP under sections III through IX. The Permittee shall submit monthly SMRs including the results of all required monitoring using U.S. EPA approved test methods or other test methods specified in this Order. SMRs are to include all new monitoring results obtained since the last SMR was submitted. If the Permittee monitors any pollutant more frequently than required by this Order, the results of this monitoring shall be included in the calculations and reporting of the data submitted in the SMR.
3. All monitoring results reported shall be supported by the inclusion of the complete analytical report from the laboratory that conducted the analyses.
4. Monitoring periods and reporting for all required monitoring shall be completed according to the following schedule:

**Table E-7. Monitoring Periods and Reporting Schedule<sup>1</sup>**

Sampling Frequency	Monitoring Period Begins On...	Monitoring Period	SMR Due Date
Daily	Permit effective date	(Midnight through 11:59 PM) or any 24-hour period that reasonably represents a calendar day for purposes of sampling	First day of second calendar month following the end of each quarter (February 1, May 1, August 1, November 1)
Weekly	Sunday following permit effective date or on permit effective date if on a Sunday	Sunday through Saturday	First day of second calendar month following the end of each quarter (February 1, May 1, August 1, November 1)
Monthly	First day of calendar month following permit effective date or on permit effective date if that date is first day of the month	First day of calendar month through last day of calendar month	First day of second calendar month following the end of each quarter (February 1, May 1, August 1, November 1)
Quarterly	Closest of January 1, April 1, July 1, or October 1 following (or on) permit effective date	January through March April through June July through September October through December	First day of second calendar month following the end of each quarter (February 1, May 1, August 1, November 1)
Annually	January 1 following (or on) permit effective date	January 1 through December 31	March 1, each year
Once per permit term	Permit effective date	All	180 days prior to permit expiration
Twice per permit term <sup>2</sup>	Permit effective date	All	180 days prior to permit expiration

**Table Notes:**

1. Quarterly monitoring periods are as follows: January 1 through March 31; April 1 through June 30; July 1 through September 30; and October 1 through December 31.
2. Sampling events shall take place at least two years apart.



- 5. Reporting Protocols.** The Permittee shall report with each sample result the applicable ML, the RL, and the current Method Detection Limit (MDL), as determined by the procedure in 40 C.F.R. part 136.

The Permittee shall report the results of analytical determinations for the presence of chemical constituents in a sample using the following reporting protocols:

- a.** Sample results greater than or equal to the reported ML shall be reported as measured by the laboratory (i.e., the measured chemical concentration in the sample).
- b.** Sample results less than the reported ML, but greater than or equal to the laboratory's MDL, shall be reported as "Detected, but Not Quantified," or DNQ. The estimated chemical concentration of the sample shall also be reported.

For the purposes of data collection, the laboratory shall write the estimated chemical concentration next to DNQ as well as the words "Estimated Concentration" (may be shortened to "Est. Conc."). The laboratory may, if such information is available, include numerical estimates of the data quality for the reported result. Numerical estimates of data quality may be percent accuracy ( $\pm$  a percentage of the reported value), numerical ranges (low to high), or any other means considered appropriate by the laboratory.

- c.** Sample results less than the laboratory's MDL shall be reported as "Not Detected" or ND.
  - d.** The Permittee is to instruct laboratories to establish calibration standards so that the ML value (or its equivalent if there is differential treatment of samples relative to calibration standards) is the lowest calibration standard. At no time is the Permittee to use analytical data derived from extrapolation beyond the lowest point of the calibration curve.
- 6.** The Permittee shall submit SMRs in accordance with the following requirements:
- a.** The Permittee shall arrange all reported data in a tabular format. The data shall be summarized to clearly illustrate whether the facility is operating in compliance with interim and/or final effluent limitations. The reported data shall include calculation of all effluent limitations that require averaging, taking of a median, or other computation. The Permittee is not required to duplicate the submittal of data that is entered in a tabular format within CIWQS. When electronic submittal of data is required and CIWQS does not provide for entry into a tabular format within the system, the Permittee shall electronically submit the data in a tabular format as an attachment.
  - b.** The Permittee shall attach a cover letter to the SMR. The information contained in the cover letter shall clearly identify:
    - i.** Facility name and address;
    - ii.** WDID number;
    - iii.** Applicable period of monitoring and reporting;
    - iv.** Violations of the WDRs (identified violations must include a description of the requirement that was violated and a description of the violation);
    - v.** Corrective actions taken or planned; and

- vi. The proposed time schedule for corrective actions.
  - c. SMRs must be submitted to the Regional Water Board, signed and certified as required by the Standard Provisions (Attachment D), to the CIWQS Program Web site (<http://www.waterboards.ca.gov/ciwqs/index.html>). In the event that an alternate method for submittal of SMRs is required, the Permittee shall submit the SMR electronically via e-mail to [NorthCoast@waterboards.ca.gov](mailto:NorthCoast@waterboards.ca.gov) or on disk (CD or DVD) in Portable Document Format (PDF) file in lieu of paper-sourced documents. The guidelines for electronic submittal of documents can be found on the Regional Water Board website at <http://waterboards.ca.gov/northcoast>.
- C. Discharge Monitoring Reports (DMRs)**
- 1. DMRs are U.S. EPA reporting requirements. The Permittee shall electronically certify and submit DMRs together with SMRs using Electronic Self-Monitoring Reports module eSMR 2.5 or any upgraded version. Electronic submittal of DMRs will be in addition to electronic submittal of SMRs. DMRs shall be submitted quarterly on the first day of the second calendar month following the end of each quarter (February 1, May 1, August 1, November 1). Information about electronic submittal of DMRs is available at the Discharge Monitoring Report web site at [http://www.waterboards.ca.gov/water\\_issues/programs/discharge\\_monitoring/](http://www.waterboards.ca.gov/water_issues/programs/discharge_monitoring/).
- D. Other Reports**
- 1. **Special Study Reports and Progress Reports.** As specified in the Special Provisions contained in section VI of the Order, special study and progress reports shall be submitted in accordance with the following reporting requirements.

**Table E-8. Reporting Requirements for Special Provisions Reports**

Order Section	Special Provision Requirement	Reporting Requirements
Effluent Limitations and Discharge Specifications IV.D (Other Requirements)	Chlorine Residual Analyzer at INT-001 Report	<b>May 1, 2019</b>
Effluent Limitations and Discharge Specifications IV.D (Other Requirements)	Continuous Chlorine Residual Analyzer at EFF-001 and EFF-003 Report	<b>May 1, 2019</b>
Special Provision VI.C.2.a	Ammonia Study Work Plan	<b>November 1, 2019</b>
Special Provision VI.C.2.a	Ammonia Study Final Report	<b>August 1, 2021</b>
Special Provision VI.C.3.a.i	Pollutant Minimization Program	As required by the Executive Officer
Special Provision VI.C.3.a.ii(e)	Pollutant Minimization Program, Annual Facility Report	<b>March 1</b> , annually, following development of Pollutant Minimization Program
Special Provision VI.C.5.b.i	Source Control and Pretreatment Provisions, Annual Report	<b>March 1</b> , annually

Order Section	Special Provision Requirement	Reporting Requirements
Special Provision VI.C.5.b.i.(c)(2)	Source Control and Pretreatment Provisions, Industrial Waste Survey and Priority Pollutant Monitoring Results	<b>March 1, 2020</b>
Special Provision VI.C.5.b.ii(a)	Source Control and Pretreatment Provisions, Notification of Discharges that Trigger Pretreatment Requirements	<b>Within 30 days</b> of discharges that trigger pretreatment requirements
Special Provision VI.C.5.b.ii(b)	Source Control and Pretreatment Provisions, Revised Report of Waste Discharge and Pretreatment Program	<b>Within 1 year</b> of discharges that trigger pretreatment requirements
Special Provision VI.C.5.f	Adequate Capacity, Technical Report	<b>Within 120 days</b> of notification that the Facility will reach capacity within 4 years
MRP General Monitoring Provision I.F	DMR-QA Study Report	<b>Annually, by March 1</b>
MRP Effluent Monitoring Requirement V.C.2	Detailed TRE Work Plan	<b>Within 30 days</b> of an accelerated monitoring test that results in "Fail"

2. **Annual Report.** The Permittee shall submit an annual report to the Regional Water Board for each calendar year through the CIWQS Program Web site. In the event that a paper copy of the annual report is required, the Permittee shall submit the report to the email address in section X.B.6.c., above. The report shall be submitted by March 1st of the following year. The report shall, at a minimum, include the following:
  - a. Both tabular and, where appropriate, graphical summaries of the monitoring data and disposal records from the previous year. If the Permittee monitors any pollutant more frequently than required by this Order, using test procedures approved under 40 C.F.R. part 136 or as specified in this Order, the results of this monitoring shall be included in the calculation and report of the data submitted SMR.
  - b. A comprehensive discussion of the Facility’s compliance (or lack thereof) with all effluent limitations and other WDRs, and the corrective actions taken or planned, which may be needed to bring the discharge into full compliance with the Order.
  - c. The names and general responsibilities of all persons employed at the Facility;
  - d. The names and telephone numbers of persons to contact regarding the Facility for emergency and routine situations.
  - e. A statement certifying when the flow meter(s) and other monitoring instruments and devices were last calibrated, including identification of who performed the calibration.
  - f. **Source Control Activity Reporting.** The Permittee shall submit, as part of its Annual Report to the Regional Water Board, a description of the Permittee’s source control activities, as required by Special Provision VI.C.5.b.i, during the past year. This annual report is due on March 1st of each year, and shall contain:
    - i. A copy of the source control standards, including a table presenting local limits.

- ii. A description of the waste hauler permit system; if applicable.
- iii. A summary of the compliance and enforcement activities taken by the Permittee during the past year, which ensures industrial user compliance. The summary shall include the names and addresses of any industrial or commercial users under surveillance by the Permittee, an explanation of whether they were inspected, sampled, or both, the frequency of these activities at each user, and the conclusions or results from the inspection or sampling of each user.
- iv. An updated list of industrial users (by North American Industrial Classification/Standard Industrial Classification categories) which were issued permits and/or enforcement orders, and a status of compliance for each user.
- v. The name and address of each user that received a discharge limit.
- vi. A summary of any industrial waste survey results.
- vii. A summary of public outreach activities to educate industrial, commercial, and residential users about the importance of preventing discharges of industrial and toxic wastes to the Facility.
- g. **Sludge Handling and Disposal Activity Reporting.** The Permittee shall submit, as part of its annual report to the Regional Water Board, a description of the Permittee's solids handling, disposal and reuse activities over the previous 12 months. At a minimum, the report shall contain:
  - i. Annual sludge production, in dry tons and percent solids;
  - ii. Sludge monitoring results;
  - iii. A schematic diagram showing sludge handling facilities (e.g., digesters, thickeners, drying beds, etc.), if any and a solids flow diagram;
  - iv. Methods of final disposal of sludge:
    - (a) For any portion of sludge discharged to a sanitary landfill, the Permittee shall provide the volume of sludge transported to the land fill, the names and locations of the facilities receiving sludge, the Regional Water Board's WDRs order number for the regulated landfill, and the landfill classification.
    - (b) For any portion of sludge discharged through land application, the Permittee shall provide the volume of biosolids applied, the date and locations where biosolids were applied, the Regional Water Board's WDRs order number for the regulated discharge, a demonstration that the discharge was conducted in compliance with applicable permits and regulations, and, if applicable, corrective actions taken or planned to bring the discharge into compliance with WDRs.
    - (c) For any portion of sludge further treated through composting, the Permittee shall provide a summary of the composting process, the volume of sludge composted, and a demonstration and signed certification statement that the composting process and final product met all requirements for Class A biosolids.

- v. Results of internal or external third-party audits of the Biosolids Management System, including reported program deficiencies and recommendations, required corrective actions, and a schedule to complete corrective actions.

**E. Spill Notification**

- 1. **Spills and Unauthorized Discharges.** Information regarding all spills and unauthorized discharges (except SSOs) that may endanger health or the environment shall be provided orally to the Regional Water Board<sup>3</sup> within 24 hours from the time the Permittee becomes aware of the circumstances and a written report shall also be provided within five (5) days of the time the Permittee becomes aware of the circumstances, in accordance with Section V.E of Attachment D.

Information to be provided verbally to the Regional Water Board includes:

- a. Name and contact information of caller;
  - b. Date, time, and location of spill occurrence;
  - c. Estimates of spill volume, rate of flow, and spill duration, if available and reasonably accurate;
  - d. Surface water bodies impacted, if any;
  - e. Cause of spill, if known at the time of the notification;
  - f. Cleanup actions taken or repairs made at the time of the notification; and
  - g. Responding agencies.
- 2. **Sanitary Sewer Overflows.** Notification and reporting of sanitary sewer overflows is conducted in accordance with the requirements of Order No. 2006-0003-DWQ (Statewide General WDRs for Sanitary Sewer Systems), which is not incorporated herein by reference, and any revisions thereto.

---

<sup>3</sup> The contact number of the Regional Water Board during normal business hours is (707) 576-2220. After normal business hours, spill reporting to the California Governor’s Office of Emergency Services Warning Center (CalOES) will satisfy the 24 hour spill reporting requirement for the Regional Water Board. The contact number for spill reporting for the CalOES is (800) 852-7550.

**ATTACHMENT F – FACT SHEET**

**Contents**

I. Permit Information..... F-3

II. Facility Description ..... F-4

    A. Description of Wastewater and Biosolids Treatment and Controls ..... F-4

    B. Discharge Points and Receiving Waters ..... F-5

    C. Summary of Existing Requirements and Self-Monitoring Report (SMR) Data ..... F-6

    D. Compliance Summary ..... F-7

    E. Planned Changes ..... F-7

III. Applicable Plans, Policies, and Regulations ..... F-7

    A. Legal Authorities ..... F-7

    B. California Environmental Quality Act (CEQA) ..... F-8

    C. State and Federal Laws, Regulations, Policies, and Plans ..... F-8

    D. Impaired Water Bodies on CWA 303(d) List..... F-10

    E. Other Plans, Policies and Regulations ..... F-11

IV. Rationale for Effluent Limitations and Discharge Specifications ..... F-12

    A. Discharge Prohibitions ..... F-12

    B. Technology-Based Effluent Limitations ..... F-15

    C. Water Quality-Based Effluent Limitations (WQBELs)..... F-17

    D. Final Effluent Limitation Considerations ..... F-31

    E. Interim Effluent Limitations..... F-33

    F. Land Discharge Specifications and Requirements – Not Applicable ..... F-33

    G. Recycling Specifications and Requirements – Not Applicable ..... F-33

    H. Other Requirements ..... F-33

V. Rationale for Receiving Water Limitations ..... F-33

    A. Surface Water ..... F-33

    B. Groundwater..... F-34

VI. Rationale for Provisions ..... F-34

    A. Standard Provisions..... F-34

    B. Special Provisions..... F-35

VII. Rationale for Monitoring and Reporting Requirements ..... F-40

    A. Influent Monitoring..... F-40

    B. Effluent Monitoring..... F-40

    C. Whole Effluent Toxicity Testing Requirements ..... F-41

    D. Receiving Water Monitoring ..... F-41

    E. Other Monitoring Requirements ..... F-42

VIII. Public Participation ..... F-43

    A. Notification of Interested Parties ..... F-43

    B. Written Comments ..... F-43

    C. Public Hearing..... F-43

    D. Waste Discharge Requirements Petitions ..... F-44

    E. Information and Copying..... F-44

    F. Register of Interested Persons ..... F-44

    G. Additional Information..... F-44

## Tables

Table F-1. Facility Information .....	F-3
Table F-2. Historic Effluent Limitations and Monitoring Data – Discharge Point 001 .....	F-6
Table F-3. Historic Effluent Limitations and Monitoring Data – Discharge Point 003 .....	F-7
Table F-4. Basin Plan Beneficial Uses.....	F-8
Table F-5. Summary of Reasonable Potential Analysis Results .....	F-23
Table F-6. Determination of Long Term Averages .....	F-25
Table F-7. Determination of Final WQBELs Based on Aquatic Life Criteria .....	F-25
Table F-8. Determination of Final WQBELs Based on Human Health Criteria .....	F-26
Table F-9. Summary of Water Quality-Based Effluent Limitations – Discharge Point 001 .....	F-26
Table F-10. Summary of Chronic Toxicity Results.....	F-27
Attachment F-1 – City of Fortuna RPA Summary.....	F-45

**ATTACHMENT F – FACT SHEET**

As described in section I, the Regional Water Board incorporates this Fact Sheet as findings of the Regional Water Board supporting the issuance of this Order. This Fact Sheet includes the legal requirements and technical rationale that serve as the basis for the requirements of this Order.

This Order has been prepared under a standardized format to accommodate a broad range of discharge requirements for dischargers in California. Only those sections or subsections of this Order that are specifically identified as “not applicable” have been determined not to apply to this Permittee. Sections or subsections of this Order not specifically identified as “not applicable” are fully applicable to this Permittee.

**I. PERMIT INFORMATION**

The following table summarizes administrative information related to the facility.

**Table F-1. Facility Information**

<b>WDID</b>	1B831350HUM
<b>Permittee</b>	City of Fortuna
<b>Name of Facility</b>	Municipal Wastewater Treatment Plant
<b>Facility Address</b>	180 Dinsmore Drive
	Fortuna, CA 95540
	Humboldt County
<b>Facility Contact, Title and Phone</b>	Douglas E. Culbert, Chief Plant Operator, (707) 725-1476
<b>Authorized Person to Sign and Submit Reports</b>	Douglas E. Culbert, Chief Plant Operator, (707) 725-1476
<b>Mailing Address</b>	P.O. Box 545, Fortuna, CA 95540
<b>Billing Address</b>	Same as Mailing Address
<b>Type of Facility</b>	Publicly Owned Treatment Works (POTW)
<b>Major or Minor Facility</b>	Major
<b>Threat to Water Quality</b>	3
<b>Complexity</b>	A
<b>Pretreatment Program</b>	No
<b>Recycling Requirements</b>	NA
<b>Facility Permitted Flow</b>	1.5 million gallons per day (mgd) (average dry weather flow) 7.0 mgd (peak wet weather flow capacity)
<b>Facility Design Flow</b>	1.5 mgd (average dry weather flow) 7.0 mgd (peak wet weather flow capacity)
<b>Watershed</b>	Eel River Hydrologic Unit; Ferndale Hydrologic Sub-Area
<b>Receiving Water</b>	Strongs Creek
<b>Receiving Water Type</b>	Inland surface water

- A. The City of Fortuna (hereinafter Permittee) is the owner and operator of the City of Fortuna Municipal Wastewater Treatment Plant (hereinafter Facility), a POTW.

For the purposes of this Order, references to the “discharger” or “permittee” in applicable federal and state laws, regulations, plans, or policy are held to be equivalent to references to the Permittee herein.



The Permittee is authorized to discharge subject to waste discharge requirements in this Order at the discharge locations described in Table 2 on the cover page of this Order. The Code of Federal Regulations at 40 C.F.R. section 122.46 limits the duration of NPDES permits to be effective for a fixed term not to exceed five years. Accordingly, Table 3 of this Order limits the effective period for the discharge authorized by this Order. Pursuant to California Code of Regulations, title 23, section 2235.4, the terms and conditions of an expired permit are automatically continued pending issuance of a new permit if all requirements of the federal NPDES regulations on continuation of expired permits are complied with.

- B. The Facility discharges treated wastewater to Strongs Creek, a water of the United States. The Permittee was previously regulated by Order No. R1-2011-0004 and National Pollutant Discharge Elimination System (NPDES) Permit No. CA0022730 adopted on January 27, 2011 and expired on January 26, 2016, and has been administratively extended since then. Attachment B provides a map of the area around the Facility. Attachment C provides a flow schematic of the Facility.
- C. The Permittee filed a report of waste discharge (ROWD) and submitted an application for reissuance of its WDRs and NPDES permit on July 15, 2015. The application was deemed complete on September 3, 2015.

## II. FACILITY DESCRIPTION

The Permittee owns and operates a municipal wastewater treatment plant (WWTP) and associated wastewater collection and disposal facilities that serve a population of 12,300 residential, commercial, and institutional users in the City of Fortuna and the Rohnerville-Campton Heights area.

### A. Description of Wastewater and Biosolids Treatment and Controls

The Facility is located to the south of the City of Fortuna, California, and east of the Eel River. Treated wastewater is discharged from Discharge Point 001 to Strongs Creek during winter discharge months and to the percolation ponds, which are hydrologically connected to the Eel River, during the summer through Discharge Point 003.

#### Collection System

Flows enter the treatment facility by gravity from the north part of the city and through a force main at a lift station on Strongs Creek. The lift station conveys sewage from the south end of the city. Sewage enters the plant north of the headworks.

#### Wastewater Treatment

The Facility is designed to treat an average dry weather flow of 1.5 mgd, and a peak wet weather flow of 7.0 mgd. When influent flows exceed 3 to 4 mgd, influent is partially diverted to an emergency overflow basin.

Wastewater in the equalization basins is returned for treatment during low flow periods. Wastewater enters the headworks, which provides grit and screenings removal with an automatic bar screen and grit channels. Primary sedimentation in one of three circular primary clarifiers settles out heavier solids, and sludge collectors in the tanks sweep the sludge into a sludge hopper where it is pumped to the anaerobic digester or gravity belt sludge thickener.

Secondary treatment includes mixing primary effluent with return-activated sludge (RAS) in the aeration basins. Mixed liquor from the aeration basins flows to two final clarifiers to settle out

activated sludge. Disinfection is achieved using chlorine gas and ammonia to form chloramines, followed by dechlorination.

Effluent is discharged to one of two discharge points, based upon the time of year. From October 1 through May 14, treated effluent is discharged through Discharge Point 001 to Strongs Creek, a tributary to the Eel River. From May 15 to September 30, treated effluent is discharged through Discharge Point 003 into two parallel percolation ponds adjacent to the Eel River. Historically, Discharge Point 003 was considered a discharge to land. Water board staff has found that the percolation ponds are below the mean high water mark of the Eel River and that water has been seen surfacing from groundwater into the percolation ponds. For these reasons, the percolation ponds are considered hydrologically connected to the Eel River and are subject to Final Effluent Limitations in this Order.

#### Biosolids

Waste activated sludge is diverted from the mixed liquor recycling line and pumped to the anaerobic digester after processing through a gravity belt thickener. Biosolids formed during the treatment process are composted for 15 days at temperatures in excess of 140 degrees Fahrenheit (°F) to destroy pathogens. Solids are tested quarterly for metals content to ensure Exceptional Quality status and the safety of the finished solids. Class A Exceptional Quality compost is given away to the community.

### **B. Discharge Points and Receiving Waters**

1. The City of Fortuna is located within the Ferndale Hydrologic Subarea of the Lower Eel River Hydrologic Area within the Eel River Hydrologic Unit. The Facility is located along Strongs Creek near the confluence of the Eel River. During October 1 through May 14, surface water discharges from Discharge Point 001 into Strongs Creek are at 40° 35' 34" N latitude and 124° 09' 30" W longitude, and enter just upstream of the confluence with the Eel River. During the summertime discharge prohibition, May 15 through September 30, the Facility has discharged to Discharge Point 003 to percolation ponds located in a gravel bar above the Eel River. These percolation ponds were considered discharges to land in Order No. R1-2011-0004. Water Board staff has observed water flowing into the percolation ponds from the subsurface and has determined that these percolation ponds are below the ordinary high water mark of the Eel River. Therefore, this Order considers any discharge to Discharge Point 003 a discharge to surface waters and subject to Final Effluent Limitations.

The main tributaries to the main stem of the Eel River are the South Fork Eel, the Middle Fork Eel, the North Fork Eel, the Van Duzen River, and Outlet, Yager, Larabee, Bull, and Salmon Creeks. The upper watershed is mountainous and vegetated by redwood and douglas fir interspersed with some hardwoods and meadows. Toward the coast, the river spreads out on a coastal plain where the Salt River joins the Eel River to form the Eel River estuary. The Eel River is designated as a Critical Coastal Area.

The Eel River Watershed Management Area (WMA) encompasses roughly 3,684 square miles in highly erodible soils in the steep coastal mountains of the Region, supporting a variety of water uses including municipal and agricultural supply systems, salmonid fisheries, and recreation. The Eel River WMA is a prime recreational area boasting numerous state and private campgrounds along its length with both water contact and non-contact uses such as boating and swimming. The Eel River is the third largest producer of salmon and steelhead in California, and supports a large recreational fishing industry. The

erodible soils, steep terrain, and other contributing factors evoke a high level of concern for the anadromous fishery resource. Coho salmon, a native species of the Eel River watershed, were listed as endangered under the federal Endangered Species Act in 1997.

**C. Summary of Existing Requirements and Self-Monitoring Report (SMR) Data**

Effluent limitations contained in Order No. R1-2011-0004 for discharges from Discharge Point 001 (Monitoring Locations M-001) and representative monitoring data from the term of Order No. R1-2011-0004 are as follows:

**Table F-2. Historic Effluent Limitations and Monitoring Data – Discharge Point 001**

Parameter	Units	Effluent Limitation			Monitoring Data (February 2011 – September 2015)		
		Average Monthly	Average Weekly	Maximum Daily	Highest Average Monthly Discharge	Highest Average Weekly Discharge	Highest Daily Discharge
Biochemical Oxygen Demand 5-day @ 20°C (BOD <sub>5</sub> )	mg/L	30	45	--	9.98	18.6	--
	lbs/day <sup>1</sup>	375	563	--	NR	NR	--
	% Removal	85	--	--	97 <sup>2</sup>	--	--
Total Suspended Solids (TSS)	mg/L	30	45	--	14.7	33.2	--
	lbs/day <sup>1</sup>	375	563	--	NR	NR	--
	% Removal	85	--	--	95 <sup>2</sup>	--	--
pH	s.u.	--	--	6.5 – 8.5	--	--	6.3 – 7.3
Settleable Solids	mL/L	0.1	--	0.2	0.14	--	0.3
Total Coliform Organisms	MPN/100 mL	23 <sup>5</sup>	--	230	--	--	<1,600 <sup>4</sup>
Chlorine, Total Residual	mg/L	0.01	--	0.02	0.91	--	1.81
Chlorodibromomethane	µg/L	0.4	--	0.8	<0.5	--	<0.5
Dichlorobromomethane	µg/L	0.6	--	1.1	2.5	--	2.5
Acute Toxicity	% Survival	70 <sup>5</sup> /90 <sup>6</sup>	--	--	95 <sup>7</sup>	--	--
<b>Table Notes:</b>							
1. Based on permitted average monthly flow of 1.5 mgd.							
2. Minimum observed percent removal.							
3. The median of all samples collected in a 7-day period.							
4. Maximum observed result.							
5. Minimum for any one bioassay.							
6. Median for any three or more consecutive bioassays.							
7. Minimum observed percent survival.							

**Table F-3. Historic Effluent Limitations and Monitoring Data – Discharge Point 003**

Parameter	Units	Effluent Limitation			Monitoring Data (February 2011 – September 2015)		
		Average Monthly	Average Weekly	Maximum Daily	Highest Average Monthly Discharge	Highest Average Weekly Discharge	Highest Daily Discharge
Biochemical Oxygen Demand 5-day @ 20°C (BOD <sub>5</sub> )	mg/L	30	45	--	9.275		--
	% Removal	85	--	--	97 <sup>2</sup>	--	--
Total Suspended Solids (TSS)	mg/L	30	45	--	33.2	33.2	--
	% Removal	85	--	--	96 <sup>2</sup>	--	--
pH	s.u.	--	--	6.5 – 8.5	--	--	6.2 – 7.4
Total Coliform Organisms	MPN/100 mL	23 <sup>5</sup>	--	230	--	--	900
<b>Table Notes:</b>							
1. Minimum observed percent removal.							
2. The median of all samples collected in a 7-day period.							
3. Maximum observed result.							

**D. Compliance Summary**

1. The Permittee was not assessed any administrative civil liability during the term of Order No. R1-2011-0004. However, a notice of violation (NOV) was issued to the Permittee through Order No. R1-2011-0050 alleging that the Permittee violated effluent limitations, reporting violations, or Water Code provisions from January 1, 2008 through October 31, 2010. The Permittee accepted a conditional resolution and waiver of right to hearing to participate in an offer of expedited payment, and paid \$9,000 as instructed in the waiver.

**E. Planned Changes**

There are no major changes planned for the Facility during this permit term.

**III. APPLICABLE PLANS, POLICIES, AND REGULATIONS**

The requirements contained in this Order are based on the requirements and authorities described in this section.

**A. Legal Authorities**

This Order is issued pursuant to section 402 of the federal Clean Water Act (CWA) and implementing regulations adopted by the U.S. Environmental Protection Agency (U.S. EPA) and chapter 5.5, division 7 of the California Water Code (commencing with section 13370). It shall serve as a NPDES permit for point source discharges from this Facility to surface waters. This Order also serves as Waste Discharge Requirements (WDRs) pursuant to article 4, chapter 4, division 7 of the Water Code (commencing with section 13260).

**B. California Environmental Quality Act (CEQA)**

Under Water Code section 13389, this action to adopt an NPDES permit is exempt from the provisions of Chapter 3 of CEQA, (commencing with section 21100) of Division 13 of the Public Resources Code.

**C. State and Federal Laws, Regulations, Policies, and Plans**

**1. Water Quality Control Plan.** The Regional Water Board adopted a *Water Quality Control Plan for the North Coast Region* (hereinafter Basin Plan) that designates beneficial uses, establishes water quality objectives, and contains implementation programs and policies to achieve those objectives for all waters addressed through the plan. In addition, the Basin Plan implements State Water Board Resolution No. 88-63, which establishes state policy that all waters, with certain exceptions, should be considered suitable or potentially suitable for municipal or domestic supply. The Basin Plan does not specifically identify beneficial uses for Strongs Creek, but does identify present and potential uses for the Eel River within the Ferndale Hydrologic Subarea of the Lower Eel River Hydrologic Area. Beneficial uses applicable to Strongs Creek are summarized in Table F-4, below:

**Table F-4. Basin Plan Beneficial Uses**

Discharge Point	Receiving Water Name	Beneficial Use(s)
001 and 003	Lower Eel River within the Ferndale Hydrologic Subarea of the Lower Eel River Hydrologic Area	<p><u>Existing:</u>                      Municipal and domestic supply (MUN);                      Agricultural supply (AGR);                      Industrial service supply (IND);                      Groundwater recharge (GWR);                      Freshwater replenishment (FRSH);                      Navigation (NAV);                      Water contact recreation (REC-1);                      Non-contact water recreation (REC-2);                      Commercial and sport fishing (COMM);                      Cold freshwater habitat (COLD);                      Wildlife habitat (WILD);                      Rare, threatened, or endangered species (RARE);                      Migration of aquatic organisms (MIGR);                      Spawning, reproduction, and/or early development (SPWN);                      Shellfish harvesting (SHELL);                      Estuarine habitat (EST); and                      Native American culture (CUL).</p> <p><u>Potential:</u>                      Industrial process supply (PRO);                      Hydropower generation (POW);                      Marine habitat (MAR), and                      Aquaculture (AQUA).</p>

In addition to the beneficial uses set out in the Basin Plan, there are several implementation plans that include actions intended to meet water quality objectives and protect beneficial

uses of the North Coast Basin. For the Eel River and its tributaries, no point source waste discharges are allowed during the period of May 15 through September 30, and during all other periods when the waste discharge flow is greater than one percent of the receiving stream's flow.

Requirements of this Order implement the Basin Plan.

2. **National Toxics Rule (NTR) and California Toxics Rule (CTR).** U.S. EPA adopted the NTR on December 22, 1992, and later amended it on May 4, 1995 and November 9, 1999. About forty criteria in the NTR applied in California. On May 18, 2000, U.S. EPA adopted the CTR. The CTR promulgated new toxics criteria for California and, in addition, incorporated the previously adopted NTR criteria that were applicable in the state. The CTR was amended on February 13, 2001. These rules contain federal water quality criteria for priority pollutants.
3. **State Implementation Policy.** On March 2, 2000, the State Water Board adopted the *Policy for Implementation of Toxics Standards for Inland Surface Waters, Enclosed Bays, and Estuaries of California* (State Implementation Policy or SIP). The SIP became effective on April 28, 2000, with respect to the priority pollutant criteria promulgated for California by the U.S. EPA through the NTR and to the priority pollutant objectives established by the Regional Water Board in the Basin Plan. The SIP became effective on May 18, 2000, with respect to the priority pollutant criteria promulgated by the U.S. EPA through the CTR. The State Water Board adopted amendments to the SIP on February 24, 2005, that became effective on July 13, 2005. The SIP establishes implementation provisions for priority pollutant criteria and objectives and provisions for chronic toxicity control. Requirements of this Order implement the SIP.
4. **Domestic Water Quality.** In compliance with Water Code section 106.3, it is the policy of the State of California that every human being has the right to safe, clean, affordable, and accessible water adequate for human consumption, cooking, and sanitary purposes. This Order promotes that policy by requiring discharges to meet maximum contaminant levels (MCLs) implemented by the Basin Plan that are designed to protect human health and ensure that water is safe for domestic use.
5. **Compliance Schedules and Interim Requirements.** The State Water Board adopted Resolution No. 2008-0025 on April 15, 2008, titled *Policy for Compliance Schedules in National Pollutant Discharge Elimination System Permits*, (Compliance Schedule Policy) which includes compliance schedule policies for pollutants that are not addressed by the SIP. This Policy became effective on August 27, 2008.

The Order includes a compliance schedule for total ammonia and total nitrate effluent limitations to comply with the Basin Plan narrative objective for biostimulatory substances. The compliance schedule is in accordance with the Compliance Schedule Policy as further discussed in section VI.B.7 of this Fact Sheet.

6. **Antidegradation Policy.** Federal regulation 40 C.F.R. section 131.12 requires that the state water quality standards include an antidegradation policy consistent with the federal policy. The State Water Board established California's antidegradation policy in State Water Board Resolution No. 68-16 (*Statement of Policy with Respect to Maintaining High Quality of Waters in California*). Resolution No. 68-16 is deemed to incorporate the federal antidegradation policy where the federal policy applies under federal law. Resolution No. 68-16 requires that existing water quality be maintained unless degradation is justified based on specific

findings. The Regional Water Board's Basin Plan implements, and incorporates by reference, both the state and federal antidegradation policies. The permitted discharge must be consistent with the antidegradation provision of 40 C.F.R. section 131.12 and State Water Board Resolution No. 68-16. As discussed in detail in section IV.D.2 of this Fact Sheet, the permitted discharge is consistent with the antidegradation provision of 40 C.F.R. section 131.12 and State Water Board Resolution No. 68-16.

- 7. Anti-Backsliding Requirements.** Sections 402(o)(2) and 303(d)(4) of the CWA and federal regulations at 40 C.F.R. section 122.44(l) restrict backsliding in NPDES permits. These anti-backsliding provisions require that effluent limitations in a reissued permit must be as stringent as those in the previous permit, with some exceptions in which limitations may be relaxed. Some effluent limitations in this Order have been removed or are less stringent than those in the previous Order. As discussed in detail in section IV.D.1 of this Fact Sheet, removal or relaxation of effluent limitations is consistent with the anti-backsliding requirements of the CWA and federal regulations.
- 8. Endangered Species Act Requirements.** This Order does not authorize an act that results in the taking of a threatened or endangered species or any act that is now prohibited, or becomes prohibited in the future, under either the California Endangered Species Act (Fish and Game Code sections 2050 to 2097) or the Federal Endangered Species Act (16 U.S.C.A sections 1531 to 1544). This Order requires compliance with effluent limits, receiving water limits, and other requirements to protect the beneficial uses of waters of the State. The Permittee is responsible for meeting all requirements of the applicable Endangered Species Act.

#### **D. Impaired Water Bodies on CWA 303(d) List**

Section 303(d) of the federal CWA requires states to identify waterbodies that do not meet water quality standards and are not supporting their beneficial uses after implementation of technology-based effluent limitations on point sources. Each state must submit an updated list, the 303(d) List of Impaired Waterbodies every 2 years. In addition to identifying the waterbodies that are not supporting beneficial uses, the 303(d) list also identifies the pollutant or stressor causing impairment and establishes a schedule for developing a control plan to address the impairment. The CWA requires development of a total maximum daily load (TMDL) or alternate program of implementation for each 303(d) listed pollutant and water body to remedy the impairment. TMDLs establish the maximum quantity of a given pollutant that can be added to a water body from all sources without exceeding the applicable water quality standard for that pollutant and determine wasteload allocations (the portion of a TMDL allocated to existing and future point sources) and load allocations (the portion of a TMDL attributed to existing and future nonpoint sources).

On June 26, 2015, the U.S. EPA provided final approval of the 2012 303(d) list of impaired water bodies for the North Coast Region prepared by the state. The list identifies the Lower Eel River Hydrologic Unit as impaired by aluminum, dissolved oxygen, sedimentation/siltation, and temperature. On December 18, 2007, the U.S. EPA approved a TMDL addressing sediment and temperature in the Lower Eel River. Pursuant to CWA section 303(d), the Regional Water Board will develop a TMDL or alternate program of implementation to address these impairments for aluminum and dissolved oxygen, which will be implemented through various programs, including through provisions of NPDES permits.

Regarding temperature, the TMDL concludes that most sources of heat in the Lower Eel River are from diffuse, nonpoint sources and result from such factors as removal of stream shade, longer travel time, changes in timing and volume of natural stream flow due to water diversions and impoundments, and increased sediment loads that cause widening of streams. As the critical time period for temperature is in the summer, the TMDL was established for that critical time period, which is also the time period when point source discharges from the Facility are prohibited. The TMDL concludes that, because of the summer discharge prohibition, area facilities such as the Facility do not contribute to temperature loadings to the Lower Eel River Watershed during critical periods, and therefore, the TMDL establishes a “zero” WLA to mean that, as long as the Permittee adheres to the summer discharge prohibition, it will be in compliance with the approved TMDL for temperature.

Regarding sediment, the TMDL establishes a maximum loading of 125 percent of the natural sediment loading for the watershed and further defines that loading rate as 2.5 tons of sediment per square mile of watershed per day on a long-term basis. Although nonpoint sources were found to be primarily responsible for excessive sediment loadings to the Lower Eel River, the TMDL established WLAs for area wastewater treatment facilities at levels corresponding to existing permit limitations for suspended solids and settleable solids. In order to be protective of the Basin Plan water quality objectives for sediment in the Lower Eel River Watershed, this Order retains effluent limitations for TSS and settleable solids from Order No. R1-2011-0004.

Regarding aluminum, the Permittee does not use any aluminum-containing chemicals in its wastewater treatment process, therefore, the Permittee’s discharge is not expected to contribute to the aluminum impairment.

#### **E. Other Plans, Policies and Regulations**

1. On May 2, 2006, the State Water Board adopted State Water Board Order No. 2006-0003-DWQ, Statewide General WDRs for Sanitary Sewer Systems and on August 6, 2013 adopted Order No. WQ 2013-0058-EXEC Amending Monitoring and Reporting Program for Statewide General Waste Discharge Requirements for Sanitary Sewer Systems. Order No. 2006-0003-DWQ requires that all public agencies that currently own or operate sanitary sewer systems apply for coverage under the General WDRs. The deadline for dischargers to apply for coverage was November 2, 2006. The Permittee applied for coverage and is subject to the requirements of Order Nos. 2006-0003-DWQ and WQ 2013-0058-EXEC and any future revisions thereto for operation of its wastewater collection system.
2. The entire treatment plant site slopes to the southwest and storm water that falls on the site drains to the equalization ponds. At low flow periods, the storm water is returned to the wastewater treatment process for treatment before being discharged. State Water Board Water Quality Order No. 2014-0057-DWQ, NPDES General Permit No. CAS000001, General Permit for Storm Water Discharges Associated with Industrial Activities (Industrial Storm Water General Permit) does not require facilities to obtain coverage if storm water is captured and treated and/or disposed of within the facility’s NPDES permitted process wastewater or if storm water is disposed of evaporation ponds, percolation ponds, or combined sewer systems. Therefore, coverage under the Industrial Storm Water General Permit is not required for this Facility.
3. On July 22, 2004, the State Water Board adopted State Water Board Order No. 2004-0012-DWQ, General Waste Discharge Requirements for the Discharge of Biosolids to Land for Use as a Soil Amendment in Agricultural, Silvicultural, Horticultural, and Land Reclamation



Activities. The Permittee must obtain coverage under Order No. 2004-0012-DWQ prior to any removal of biosolids from the Facility that will be land disposed on property owned or controlled by the Permittee.

4. When applicable, state law requires dischargers to file a petition with the State Water Board, Division of Water Rights, and receive approval for any change in the point of discharge, place of use, or purpose of use of treated wastewater that decreases the flow in any portion of the watercourse. The State Water Board retains separate jurisdictional authority to enforce any applicable requirements under Water Code section 1211. This is not an NPDES permit requirement.
5. On August 4, 2015, the State Water Board adopted State Water Board Order WQ 2015-0121-DWQ, General Waste Discharge Requirements for Composting Operations. The Permittee must maintain coverage under Order WQ 2015-0121-DWQ for any composting operations at the Facility. The Permittee submitted a NOI for coverage under Order WQ 2015-0121-DWQ on April 27, 2016.

#### IV. RATIONALE FOR EFFLUENT LIMITATIONS AND DISCHARGE SPECIFICATIONS

The CWA requires point source dischargers to control the amount of conventional, non-conventional, and toxic pollutants that are discharged into the waters of the United States. The control of pollutants discharged is established through effluent limitations and other requirements in NPDES permits. There are two principal bases for effluent limitations in the Code of Federal Regulations: 40 C.F.R. section 122.44(a) requires that permits include applicable technology-based limitations and standards; and 40 C.F.R. section 122.44(d) requires that permits include WQBELs to attain and maintain applicable numeric and narrative water quality criteria to protect the beneficial uses of the receiving water where a reasonable potential to exceed those criteria exist.

##### A. Discharge Prohibitions

1. **Discharge Prohibition III.A.** The discharge of any waste not disclosed by the Permittee or not within the reasonable contemplation of the Regional Water Board is prohibited.

This prohibition is based on the Basin Plan, Order No. R1-2011-0004, and State Water Board Order No. WQO 2002-0012 regarding the petition of WDRs Order No. 01-072 for the East Bay Municipal Utility District and Bay Area Clean Water Agencies. In State Water Board Order No WQO 2002-0012, the State Water Board found that this prohibition is acceptable in orders, but should be interpreted to apply only to constituents that are either not disclosed by the Permittee, or are not reasonably anticipated to be present in the discharge but have not been disclosed by the Permittee. It specifically does not apply to constituents in the discharge that do not have "reasonable potential" to exceed water quality objectives.

The State Water Board has stated that the only pollutants not covered by this prohibition are those which were "*disclosed to the permitting authority and...can be reasonably contemplated.*" [In re the Petition of East Bay Municipal Utilities District et al., (State Water Board, 2002) Order No. WQO 2002-0012, p. 24.] In that Order, the State Water Board cited a case which held the Permittee is liable for the discharge of pollutants "*not within the reasonable contemplation of the permitting authority...whether spills or otherwise...*" [*Piney Run Preservation Assn. v. County Commissioners of Carroll County, Maryland* (4<sup>th</sup> Cir. 2001) 268 F. 3d 255, 268.] Thus the State Water Board authority provides that, to be permissible, the constituent discharged (1) must have been disclosed by the Permittee and (2) can be reasonably contemplated by the Regional Water Board.

- 2. Discharge Prohibition III.B.** Creation of pollution, contamination, or nuisance, as defined by section 13050 of the Water Code is prohibited.

This prohibition has been retained from Order No. R1-2011-0004 and is based on section 13050 of the Water Code and section 5411 of the California Health and Safety Code.

- 3. Discharge Prohibition III.C.** The discharge of sludge or digester supernatant is prohibited, except as authorized under section VI.C.5.c of this Order (Sludge Disposal and Handling Requirements).

This prohibition has been retained from Order No. R1-2011-0004 and is based on restrictions on the disposal of sewage sludge found in federal regulations [40 C.F.R. Part 503 (Biosolids), Part 527, and Part 258] and title 27 of the California Code of Regulations (CCR).

- 4. Discharge Prohibition III.D.** The discharge of untreated or partially treated waste (receiving a lower level of treatment than described in section II.A of the Fact Sheet) from anywhere within the collection, treatment, or disposal systems is prohibited, except as provided for in Attachment D, Standard Provisions G (Bypass) and H (Upset).

This prohibition has been retained from Order No. R1-2011-0004 and is based on the Basin Plan to protect the beneficial uses of the receiving water from unpermitted discharges, and the intent of the Water Code sections 13260 through 13264 relating to the discharge of waste to waters of the state without filing for and being issued an Order. This prohibition applies to spills not related to sanitary sewer overflows (SSOs) and other unauthorized discharges of wastewater within the collection, treatment, and disposal facilities. The discharge of untreated or partially treated wastewater from the collection, treatment, or disposal facility represents an unauthorized bypass pursuant to 40 C.F.R. section 122.41(m) or an unauthorized discharge which poses a threat to human health and/or aquatic life, and therefore is explicitly prohibited by this Order.

- 5. Discharge Prohibition III.E.** Any SSO that results in a discharge of untreated or partially treated wastewater to (a) waters of the state or (b) land that creates pollution, contamination, or nuisance, as defined in Water Code section 13050(m) is prohibited.

This prohibition is established in this Order. A reference to groundwater has been removed because groundwater is captured in the broader term, "waters of the state." This prohibition applies to spills related to SSOs and is based on state standards, including section 13050 of the Water Code and the Basin Plan. This prohibition is consistent with the state's antidegradation policy as specified in State Water Board Resolution No. 68-16 (*Statement of Policy with Respect to Maintaining High Quality of Water in California*) in that the prohibition imposes conditions to prevent impacts to water quality, the degradation of water quality, negative effects on receiving water beneficial uses, and lessening of water quality beyond that prescribed in State Water Board or Regional Water Board plans and policies.

This prohibition is stricter than the prohibitions stated in State Water Board Order 2006-003-DWQ, Statewide General Waste Discharge Requirements for Sanitary Sewer Systems. Order No. 2006-0003-DWQ prohibits SSOs that result in the discharge of untreated or partially treated wastewater to waters of the United States and SSOs that cause a nuisance, compared to Prohibition III.E of this Order, which prohibits SSO discharges that create nuisance or pollution to waters of the state and land for a more complete protection of human health. The rationale for this prohibition is because of the prevalence of high

groundwater in the North Coast Region, and this Region's reliance on groundwater as a drinking water source.

6. **Discharge Prohibition III.F.** The discharge of waste to land that is not owned by the Permittee, governed by City ordinance, or under agreement to use by the Permittee, or for which the Permittee has explicitly permitted such use, is prohibited, except for use for fire suppression as provided in title 22, section 60307(b) of the California Code of Regulations (CCR).

This prohibition is retained from Order No. R1-2011-0004, with minor modifications. Land used for the application of wastewater must be owned by the Permittee or be under the control of the Permittee by contract so that the Permittee maintains a means for ultimate disposal of treated wastewater.

7. **Discharge Prohibition III.G.** The discharge of waste at any point not described in Finding II.B of the Fact Sheet or authorized by a permit issued by the State Water Board or another Regional Water Board is prohibited.

This prohibition has been retained from Order No. R1-2011-0004. This prohibition is a general prohibition that allows the Permittee to discharge waste only in accordance with WDRs. It is based on sections 301 and 402 of the federal CWA and section 13263 of the Water Code.

8. **Prohibition III.H.** The average dry weather flow of waste through the Facility shall not exceed 1.5 mgd measured daily and averaged over a calendar month. The peak daily wet weather flows through the Facility shall not exceed 7.0 mgd. Compliance with this prohibition shall be determined as defined in sections VII.K and VII.L of this Order.

This prohibition is established by this Order and is based on the average dry weather and peak wet weather discharge treatment capacity of the Facility. Exceedance of this capacity on a daily basis may result in effluent violations and/or the need to by-pass untreated effluent blended with treated effluent, which is prohibited.

9. **Discharge Prohibition III.I.** The discharge of waste to the Eel River and its tributaries is prohibited during the period from May 15 through September 30 of each year.

This prohibition is required by the Basin Plan. The Basin Plan prohibits discharges to the Eel River and its tributaries during the period May 15 through September 30 (Chapter 4, Waste Discharge prohibitions for the North Coastal Basin).

10. **Prohibition III.J.** During the period from October 1 through May 14 of each year, discharges of treated wastewater to Strongs Creek, a tributary to the Eel River, shall not exceed one percent of the flow of the Eel River as measured by the sum of the flows at the United States Geological Survey (USGS) Station in the Eel River near Scotia and at USGS Station 11478500 in the Van Duzen River near Bridgeville. For the purposes of this Order, compliance with this discharge prohibition shall be determined as follows:

- a. The discharge of secondary treated wastewater shall be adjusted at least once daily to avoid exceeding, to the extent practicable, one percent of the most recent daily flow measurement of the Eel River;
- b. Daily flow shall be based on flow meter comparisons reasonably read between the hours of 12:01 am and 12:00 midnight; and

- c. In no case shall the total volume of secondary treated wastewater discharged in a calendar month exceed one percent of the total volume of the Eel River in the same calendar month. At the beginning of the discharge season, the monthly flow volume comparisons shall be based on the date when the discharge commenced to the end of the calendar month. At the end of the discharge season, the monthly flow volume shall be based on the first day of the calendar month to the date when the discharge ceased for the season.

This prohibition has been retained from Order No. R1-2011-0004 and is required by the Basin Plan (Chapter 4, North Coastal Basin Discharge Prohibition No. 3). The Basin Plan prohibits discharges to the Eel River and its tributaries when the waste discharge flow is greater than one percent of the receiving water's flow. Basin Plan Prohibition No. 3 does not specify how compliance to the one-percent flow requirement will be determined. This prohibition, set forth in Provision III.I of this Order, specifies that the discharge may comply with the one percent requirement as a monthly average for the surface water discharge season if USGS Stations 1147700 and 11478500 are read at least once daily, and the discharge flow rate shall not be set for greater than one percent of the flow of the river at the time of the daily reading.

11. **Prohibition III.K.** The discharge of any radiological, chemical, or biological warfare agent or high-level radioactive waste into waters of the state is prohibited.

This prohibition is established in this Order and is based on the discharge prohibitions contained in and section 13375 of the Water Code.

12. **Prohibition III.L.** The acceptance of septage to a location other than an approved septage receiving station is prohibited.

This prohibition is newly established by this Order and is necessary to ensure that septage is not accepted in the absence of a septage management program to ensure that pollutants associated with domestic septage do not pass through or interfere with the operation or performance of the Facility.

## **B. Technology-Based Effluent Limitations**

### **1. Scope and Authority**

Section 301(b) of the CWA and implementing U.S. EPA permit regulations at 40 C.F.R. section 122.44 require that permits include conditions meeting applicable technology-based requirements at a minimum, and any more stringent effluent limitations necessary to meet applicable water quality standards. The discharge authorized by this Order must meet minimum federal technology-based requirements based on Secondary Treatment Standards at 40 C.F.R.

Regulations promulgated in 40 C.F.R. section 125.3(a)(1) require technology-based effluent limitations for municipal dischargers to be placed in NPDES permits based on Secondary Treatment Standards or Equivalent to Secondary Treatment Standards.

The Federal Water Pollution Control Act Amendments of 1972 (PL 92-500) established the minimum performance requirements for POTWs [defined in section 304(d)(1)]. Section 301(b)(1)(B) of that Act requires that such treatment works must, as a minimum, meet effluent limitations based on secondary treatment as defined by the U.S. EPA Administrator.

Based on this statutory requirement, U.S. EPA developed secondary treatment regulations, which are specified in 40 C.F.R. part 133. These technology-based regulations apply to all municipal wastewater treatment plants and identify the minimum level of effluent quality attainable by secondary treatment in terms of BOD<sub>5</sub>, TSS, and pH, as follows:

**a. BOD<sub>5</sub> and TSS**

- i. The 30-day average shall not exceed 30 mg/L.
- ii. The 7-day average shall not exceed 45 mg/L.
- iii. The 30-day average percent removal shall not be less than 85%.

**b. pH**

- i. The pH shall be maintained within the limits of 6.0 to 9.0.
- ii. The effluent limitation for pH required to meet the water quality objective for hydrogen ion concentration (pH) is contained in the Basin Plan, Table 3-1.

In addition, 40 C.F.R. section 122.45(f) requires the establishment of mass-based effluent limitations for all pollutants limited in Orders, except for 1) pH, temperature, radiation, or other pollutants which cannot be appropriately expressed by mass, 2) when applicable standards and limitations are expressed in terms of other units of measure.

**2. Applicable Technology-Based Effluent Limitations**

The effluent limitations in this Order for BOD<sub>5</sub>, TSS, and pH not only meet the technology-based requirements for secondary treatment set forth in section 133.102, but they also are required to meet the water quality-based requirements set forth in the Basin Plan.

- a. BOD<sub>5</sub> and TSS.** As described above, the secondary treatment standards at 40 C.F.R. part 133 establish the minimum level of effluent quality attainable by secondary treatment in terms of BOD<sub>5</sub>, TSS, and pH. Numeric effluent limitations for BOD<sub>5</sub>, TSS, and pH, including the percent removal requirements for BOD<sub>5</sub> and TSS, are retained from Order No. R1-2011-0004 and reflect the secondary treatment standards at 40 C.F.R. part 133.
- b. pH.** The secondary treatment regulations at 40 C.F.R. part 133 require that pH be maintained between 6.0 and 9.0 standard units. Note that a more stringent effluent limitation range of 6.5 – 8.5 for pH is required to meet the water quality objective for hydrogen ion concentration (pH) in the Eel River contained in Basin Plan, Table 3-1.
- c. Mass-Based Effluent Limitations.** Federal regulations at 40 C.F.R. section 122.45(f) require that, except under certain conditions, all permit limits, standards, or prohibitions be expressed in terms of mass units. Among the conditions exempting the application of mass-based limitations is section 40 C.F.R. section 122.45(f)(1)(i), which states *“for pH, temperature, and radiation, or other pollutants which cannot appropriately be expressed by mass”*

This Order does not include mass-based effluent limitations for the following pollutants pursuant to the exception in 40 C.F.R. sections 122.45(f)(1)(i) and (ii):

- i. BOD<sub>5</sub> and TSS, because these two parameters are expressed in terms of concentration and percent removal; and

- ii. pH, because this parameters cannot appropriately be expressed by mass.

**C. Water Quality-Based Effluent Limitations (WQBELs)**

**1. Scope and Authority**

CWA Section 301(b) and 40 C.F.R. section 122.44(d) require that permits include limitations more stringent than applicable federal technology-based requirements where necessary to achieve applicable water quality standards.

Section 122.44(d)(1)(i) of 40 C.F.R. requires that permits include effluent limitations for all pollutants that are or may be discharged at levels that have the reasonable potential to cause or contribute to an exceedance of a water quality standard, including numeric and narrative objectives within a standard. Where reasonable potential has been established for a pollutant, but there is no numeric criterion or objective for the pollutant, WQBELs must be established using: (1) U.S. EPA criteria guidance under CWA section 304(a), supplemented where necessary by other relevant information; (2) an indicator parameter for the pollutant of concern; or (3) a calculated numeric water quality criterion, such as a proposed state criterion or policy interpreting the state's narrative criterion, supplemented with other relevant information, as provided in section 122.44(d)(1)(vi).

The process for determining reasonable potential and calculating WQBELs when necessary is intended to protect the designated uses of the receiving water as specified in the Basin Plan, and achieve applicable water quality objectives and criteria that are contained in other state plans and policies, or any applicable water quality criteria contained in the CTR and NTR.

**2. Applicable Beneficial Uses and Water Quality Criteria and Objectives**

- a. **Beneficial Uses.** Beneficial use designations for receiving waters for discharges from the Facility are presented in section III.C.1 of this Fact Sheet.
- b. **Basin Plan Water Quality Objectives.** In addition to the specific water quality objectives indicated above, the Basin Plan contains narrative objectives for color, tastes and odors, floating material, suspended material, settleable material, oil and grease, biostimulatory substances, sediment, turbidity, pH, dissolved oxygen, bacteria, temperature, toxicity, pesticides, chemical constituents, and radioactivity that apply to inland surface waters, enclosed bays, and estuaries, including the Eel River and its tributaries. For waters designated for use as MUN, the Basin Plan establishes as applicable water quality criteria the MCLs established by the DDW for the protection of public water supplies at title 22 of the CCR section 64431 (Inorganic Chemicals) and section 64444 (Organic Chemicals).
- c. **SIP, CTR, and NTR.** Water quality criteria and objectives applicable to this receiving water are established by the CTR, established by the U.S. EPA at 40 C.F.R. section 131.38; and the NTR, established by the U.S. EPA at 40 C.F.R. section 131.36. Criteria for most of the 126 priority pollutants are contained within the CTR and the NTR.

The SIP, which is described in section III.C.3 of this Fact Sheet, includes procedures for determining the need for, and the calculation of, WQBELs and requires Permittees to submit data sufficient to do so.

At title 22, division 4, chapter 15 of the CCR, DDW has established MCLs for certain pollutants for the protection of drinking water. Chapter 3 of the Basin Plan establishes these MCLs as water quality objectives applicable to receiving waters with the beneficial use designation of municipal and domestic supply.

Aquatic life freshwater and saltwater criteria are identified as criterion maximum concentrations (CMC) and criterion continuous concentrations (CCC). The CTR defines the CMC as the highest concentration of a pollutant to which aquatic life can be exposed for a short period of time without deleterious effects and the CCC as the highest concentration of a pollutant to which aquatic life can be exposed for an extended period of time (4 days) without deleterious effects. The CMC is used to calculate an acute or 1-hour average numeric effluent limitation and the CCC is used to calculate a chronic or 4-day average numeric effluent limitation. Aquatic life freshwater criteria were used for the RPA.

Human health criteria are further identified as “water and organisms” and “organisms only”. “Water and organism” criteria are designed to address risks to human health from multiple exposure pathways. The criteria from the “water and organisms” column of CTR were used for the RPA because the Basin Plan identifies that the receiving water, Strongs Creek (tributary to the Eel River), has the beneficial use designation of municipal and domestic supply.

### 3. Determining the Need for WQBELS

NPDES regulations at 40 C.F.R. section 122.44(d) require effluent limitations to control all pollutants which are or may be discharged at a level which will cause, have the reasonable potential to cause, or contribute to an excursion above any state water quality standard. The RPA for this Facility was conducted as follows.

#### a. Non-Priority Pollutants

- i. **pH.** The effluent limitation for pH of 6.5 to 8.5 is retained from Order No. R1-2011-0004. This limitation is based on the water quality objective for all surface waters established in Chapter 3, Table 3-1 of the Basin Plan. Federal technology-based requirements prescribed in 40 C.F.R. part 133 are not sufficient to meet these Basin Plan water quality standards.
- ii. **Coliform Bacteria.** Coliform bacteria are a pollutant of concern in all wastewaters of domestic origin, and therefore this Order includes effluent limitations for total coliform bacteria. These effluent limitations will ensure that water quality objectives for bacteria, as established by Chapter 3 of the Basin Plan, will be maintained. The effluent limitations for total coliform bacteria in Order No. R1-2011-0004 have been updated to reflect standards for secondary treated recycled water in the Basin Plan (Section 4, Implementation Plans) and as established by DDW at title 22, division 4, chapter 3 of the CCR.
- iii. **Settleable Solids.** High levels of settleable solids can have an adverse effect on aquatic habitat. Untreated or improperly treated wastewater can contain high amounts of settleable solids. The Eel River and its tributaries are listed as impaired for sediment and settleable solids. Monthly average and maximum daily effluent limitations for settleable solids of 0.1 ml/L and 0.2 ml/L have been retained from Order No. R1-2011-0004. These limitations reflect levels of

treatment attainable by secondary treatment facilities. This limitation is based on the water quality objective prohibiting bottom deposits for all surface waters of the North Coast Region established by the Basin Plan and is needed due to the 303(d) listing for sediment in the Lower Eel River.

- iv. **Chlorine Residual.** The Basin Plan establishes a narrative water quality objective for toxicity which states “[a]ll waters shall be maintained free of toxic substances in concentrations that are toxic to, or that produce detrimental physiological responses in human, plant, animal, or aquatic life.” The Regional Water Board considers any chlorinated discharge as having the reasonable potential to cause or contribute to exceedances of this water quality objective for toxicity, and therefore this Order establishes effluent limitations for chlorine. U.S.EPA has established the following criteria for chlorine-produced oxidants for protection of freshwater aquatic life in Quality Criteria for Water 1986 (The Gold Book, 1986, EPA 440/5-86-001).

Chronic Criterion	Acute Criterion
0.011 mg/L	0.019 mg/L

Consistent with Order No. R1-2011-0004, the water quality criteria for total chlorine residual recommended by U.S. EPA have been translated to an AMEL of 0.01 mg/L and an MDEL of 0.02 mg/L in this Order.

- v. **Nitrogen Compounds.** Untreated domestic wastewater contains ammonia nitrogen. Nitrification is a biological process that converts ammonia to nitrite and nitrate. Denitrification is a process that converts nitrate to nitrogen gas, which is then released to the atmosphere. Inadequate or incomplete nitrification may result in the discharge of ammonia to the receiving stream and inadequate or incomplete denitrification may result in the discharge of nitrate to the receiving stream. The Facility is designed to use nitrification to remove ammonia from the waste stream and denitrification to remove nitrate from the waste stream, culminating in an overall reduction in total nitrogen.

- (a) **Nitrate.** Nitrate is known to cause adverse health effects in humans. For waters designated as domestic or municipal supply, the Basin Plan (Chapter 3) adopts the MCLs, established by DDW for the protection of public water supplies at title 22 of the CCR, sections 64431 (Inorganic Chemicals) and 64444 (Organic Chemicals), as applicable water quality criteria. The MCL for nitrate (10 mg/L as N) is therefore applicable as a water quality criterion. The Permittee sampled its discharge monthly between January 2011 and September 2015. Monitoring results ranged between 3.3 mg/L and 33 mg/L based on 27 samples. Because nitrate levels in effluent have been measured at concentrations greater than 10 mg/L N, the Regional Water Board concludes that discharges from the Facility have a reasonable potential to cause or contribute to exceedances of applicable water quality criteria for the receiving water for nitrate. Effluent limitations will be established for nitrate consisting of an average monthly effluent limitation (AMEL) of 10 mg/L and a maximum daily effluent limitation (MDEL) of 18 mg/L.



- (b) Ammonia.** Ammonia is known to cause toxicity to aquatic organisms in surface waters. The Basin Plan establishes a narrative water quality objective for toxicity, stating that “[a]ll waters shall be maintained free of toxic substances in concentrations that are toxic to, or that produce detrimental physiological responses in human, plant, animal, or aquatic life.” Due to concerns regarding ammonia toxicity, the Regional Water Board relies on U.S. EPA’s recommended water quality criteria for ammonia to interpret the Basin Plan’s narrative objective for toxicity. For freshwater, the recommended criteria are from the April 2013 *Aquatic Life Ambient Water Quality Criteria for Ammonia – Freshwater*, EPA 822-R-13-001 (2013 Freshwater Criteria). The 2013 Freshwater Criteria is an update to the December 1999 *Update of Ambient Water Quality Criteria for Ammonia* (1999 Freshwater Criteria).

The 2013 Freshwater Criteria recommends acute and chronic water quality criteria for the protection of aquatic life, including salmonids and sensitive freshwater mussel species in the Family Unionidae that are more sensitive to ammonia than salmonids. Like the 1999 Freshwater Criteria document, the 2013 Freshwater Criteria document recommends acute (1-hour average) criteria based on pH and the presence/absence of salmonids and chronic (30-day average) criteria based on pH and temperature and that no 4-day average concentration should exceed 2.5 times the 30-day chronic criterion. In addition, the 2013 Freshwater Criteria document recommends these same criteria for the sensitive mussel species.

Adequate information is not available to determine if these freshwater mussels are present in the receiving water. The 2013 Freshwater Criteria document states, “*In the case of ammonia, where a state demonstrates that mussels are not present on a site-specific basis, the recalculation procedure may be used to remove the mussel species from the national criteria dataset to better represent the species present at the site.*” This Order includes a special study requirement in Special Provision VI.C.2.a requiring the Permittee to conduct a study to determine the presence of mussels in the receiving water. Until the study is completed, the Regional Water Board will implement the 2013 Freshwater Criteria with the assumed presence of salmonids and assumed absence of mussels to interpret the Basin Plan’s narrative toxicity objective.

For this Order, the Regional Water Board has considered the actual conditions documented in the receiving water for discharges from the Facility (paired receiving water pH of 7.77 and temperature of 11.11°C at Monitoring Location RSW-001, the assumed presence of salmonids and absence of mussels) to calculate U.S. EPA’s 2013 recommended criteria for protection of aquatic life, which result in acute and chronic criteria of 9.64 mg/L and 4.43 mg/L, respectively.

The maximum observed effluent ammonia concentration from the Facility was 13 mg/L, based on 27 samples collected between January 2011 and September 2015. No receiving water ammonia data was available.

Because ammonia levels in the effluent and receiving water have been measured at concentrations greater than U.S. EPA's 2013 recommended water quality criteria for fresh waters, the Regional Water Board concludes that discharges from the Facility have a reasonable potential to cause or contribute to exceedances of the Basin Plan's applicable narrative water quality criterion for toxicity. Therefore, this Order includes effluent limitations for ammonia for the protection of aquatic life. This Order establishes an AMEL of 3.6 mg/L and maximum daily effluent limitation (MDEL) of 9.6 mg/L for total ammonia, expressed as N. Calculations of these effluent limitations are included in section IV.C.4 of this Fact Sheet.

- vi. **Biostimulatory Substances (Phosphorus and Nitrogen).** The Basin Plan contains a narrative water quality objective for biostimulatory substances that states “[w]aters shall not contain biostimulatory substances in concentrations that promote aquatic growths to the extent that such growths cause nuisance or adversely affect beneficial uses.” The Regional Water Board is increasingly concerned about the biostimulatory properties of discharges to surface waters in the North Coast Region. Nutrients, such as phosphorus and nitrogen containing compounds, in treated wastewater stimulate biological growth, thereby depleting dissolved oxygen and advancing eutrophication of receiving waters. At present, for interpretation of the Basin Plan's narrative water quality objective for biostimulatory substances, U.S. EPA has established recommended water quality criteria for nutrients in *Nutrient Criteria Documents for Lakes and Rivers and Nutrient Criteria Documents for Rivers and Streams*. U.S. EPA has defined 14 “ecoregions” and further categorized surface waters as lakes and reservoirs or rivers and streams for purposes of defining applicable numeric water quality criteria for nutrients. The State and Regional Water Boards continue to examine other methods of interpreting the Basin Plan's narrative water quality objective for biostimulatory substances. When the Boards determine that U.S. EPA's recommended criteria are appropriate for implementing the Basin Plan objectives, or when a more appropriate and meaningful method is established, the need for limiting nutrients in relation to biostimulatory properties, including phosphorus and nitrogen-containing compounds, in all discharges in the Region will be reassessed. In the meantime, the RPA for nutrients in relation to biostimulatory properties, performed for development of this Order, is inconclusive. The Order retains monitoring requirements for phosphorus and nitrogen containing compounds in discharges from the Facility to allow a determination of reasonable potential at such time as the State and Regional Water Boards select an appropriate method for interpretation of the Basin Plan's narrative objective.

**b. Priority Pollutants**

The SIP establishes procedures to implement water quality criteria from the NTR and CTR and for priority, toxic pollutant objectives established in the Basin Plan. The implementation procedures of the SIP include methods to determine reasonable potential (for pollutants to cause or contribute to excursions above state water quality standards) and to establish numeric effluent limitations, if necessary, for those pollutants showing reasonable potential.

Section 1.3 of the SIP requires the Regional Water Board to use all available, valid, relevant, and representative receiving water and effluent data and information to conduct an RPA. During the term of Order No. R1-2011-0004, priority pollutant sampling was conducted on February 11, 2015 (effluent and receiving water). All of this data was used for the RPA.

**Hardness:** The CTR and the NTR contain water quality criteria for seven metals that vary as a function of hardness; the lower the hardness, the lower the water quality criteria. The SIP requires water quality criteria be properly adjusted for hardness, using the hardness of the receiving water. The hardness-dependent metal criteria include cadmium, copper, chromium (III), lead, nickel, silver, and zinc. The receiving water hardness ranged from 56 mg/L to 160 mg/L based on 14 samples collected between January 2011 and September 2015. For the RPA, the minimum observed receiving water hardness of 56 mg/L was used to calculate the criteria.

To conduct the RPA, Regional Water Board staff identified the maximum effluent concentration (MEC) and maximum background (B) concentration for each priority, toxic pollutant from effluent and receiving water data provided by the Permittee, and compared this information to the most stringent applicable water quality criterion (C) for each pollutant with applicable water quality criteria from the NTR, CTR, and the Basin Plan. Section 1.3 of the SIP establishes three triggers for a finding of reasonable potential.

**Trigger 1.** If the MEC is greater than C, there is reasonable potential, and an effluent limitation is required.

**Trigger 2.** If B is greater than C, and the pollutant is detected in effluent (MEC > ND), there is reasonable potential, and an effluent limitation is required.

**Trigger 3.** After a review of other available and relevant information, a permit writer may decide that a WQBEL is required. Such additional information may include, but is not limited to: the facility type, the discharge type, solids loading analyses, lack of dilution, history of compliance problems, potential toxic impact of the discharge, fish tissue residue data, water quality and beneficial uses of the receiving water, CWA 303(d) listing for the pollutant, and the presence of endangered or threatened species or their critical habitat.

**c. Reasonable Potential Determination**

The RPA demonstrated reasonable potential for discharges of dichlorobromomethane and heptachlor epoxide from the Facility to cause or contribute to exceedances of applicable water quality criteria. Reasonable potential could not be determined for all pollutants, as there are not applicable water quality criteria for all pollutants. The RPA determined that there is either no reasonable potential or there was insufficient information to conclude affirmative reasonable potential for 124 of the 126 priority pollutants.

Table F-5 summarizes the RPA for each pollutant that was reported in detectable concentrations in the effluent or the receiving water. The MECs, most stringent water quality objectives/water quality criteria (WQO/WQCs), and background concentrations (B) used in the RPA are presented, along with the RPA results (Yes or No and which trigger) for each toxic pollutant analyzed. No other pollutants with applicable, numeric

water quality criteria from the NTR, CTR, and the Basin Plan were measured above detectable concentrations during the monitoring events conducted by the Permittee. Attachment F-1 to this Order summarizes the RPA for all 126 priority pollutants.

**Table F-5. Summary of Reasonable Potential Analysis Results**

CTR #	Pollutant	Unit	C or Most Stringent WQO/WQC	MEC or Minimum DL <sup>1</sup>	B or Minimum DL	RPA Results <sup>2</sup>
1	Antimony	µg/L	6	0.113	0.104	No
6	Copper	µg/L	26 <sup>3</sup>	16	4.9	No
7	Lead	µg/L	1.5	0.176	1.25	No
9	Nickel	µg/L	32	3.17	13.3	No
10	Selenium	µg/L	5	0.23	<0.168	No
13	Zinc	µg/L	73	24.2	12.5	No
27	Dichlorobromomethane	µg/L	0.56	2.5	--	Yes (Trigger 1)
39	Toluene	µg/L	150	0.68	<0.5	No
114	Endosulfan Sulfate	µg/L	110	0.027	<0.0023	No
118	Heptachlor Epoxide	µg/L	0.0001	0.012	0.013	Yes (Trigger 1)
Not Applicable	Ammonia	mg/L	2.03 <sup>4</sup>	13	--	Yes (Trigger 1)
Not Applicable	Nitrate (as N)	mg/L	10	33	--	Yes (Trigger 1)

**Table Notes:**

- The Maximum Effluent Concentration (MEC) or maximum background concentration (B) is the actual detected concentration unless it is preceded by "<", in which case the value shown is the minimum detection level as the analytical result was reported as not detected (ND).
- RPA Results:  
 = Yes, if MEC > WQO/WQC, or B > WQO/WQC and MEC is detected.  
 = No, if MEC and B < WQO/WQC or all effluent data are undetected.  
 = Undetermined (UD).
- Copper WQO calculated with a WER of 4.63 and the most stringent WQO from the CTR using the lowest receiving water hardness of 56 mg/L (4.63 x 5.6 = 26 mg/L).
- Ammonia criteria are determined on a sliding scale based upon temperature and pH. The criterion represented in this table is based upon chronic exposure and a temperature of 11.11°C and a pH of 7.7.

Additional details regarding priority pollutant constituents for which reasonable potential was found are included in the following paragraphs:

Dichlorobromomethane. The CTR establishes a water quality objective for the protection of human health for dichlorobromomethane of 0.56 µg/L. The Permittee sampled the effluent for dichlorobromomethane 30 times during the term of Order No. R1-2011-0004. Dichlorobromomethane was detected in the effluent in seven out of 30 samples with results ranging from 0.61 µg/L to 2.5 µg/L. No receiving water data for dichlorobromomethane was available. A determination of reasonable potential has been made based on the MEC of 2.5 µg/L exceeding the most stringent water quality objective of 0.56 µg/L.

Heptachlor Epoxide. The CTR establishes a water quality objective for the protection of human health for heptachlor epoxide of 0.0001 µg/L. The Permittee sampled the effluent for heptachlor epoxide one time, on February 11, 2015. The result of this single sampling event was 0.012 µg/L. Heptachlor epoxide was sampled once in the receiving water with a maximum concentration of 0.013 µg/L. A determination of reasonable potential has been made based on the MEC of 0.012 µg/L exceeding the most stringent water quality objective of 0.0001 µg/L.

Additional details regarding constituents for which reasonable potential was not found but warrant further explanation are included in the following paragraph:

Copper. The CTR includes hardness-dependent criteria for the protection of freshwater aquatic life for copper. The criteria for copper are presented in dissolved concentrations. U.S. EPA recommends conversion factors to translate dissolved concentrations to total concentrations. The U.S. EPA default conversion factors for copper in freshwater are 0.96 for both the acute and the chronic criteria. The default water effects ratio (WER) used for calculating criteria for copper is 1.0. The Permittee has conducted a WER study to determine the site-specific toxicity of copper in the receiving water at the point of discharge. The Permittee's study concluded that a site specific WER of 4.63 for total recoverable copper and 3.9 for dissolved copper apply to the discharge. Using the worst-case measured hardness from the receiving water (56 mg/L), the U.S. EPA recommended dissolved-total translator of 0.96, and the site-specific WER, the applicable chronic criterion (maximum 4-day average concentration) is adjusted to 26 µg/L and the applicable acute criterion (maximum 1-hour average concentration) is adjusted to 38 µg/L. The MEC measured for copper was 16 µg/L, based on 28 results obtained between February 2011 and September 2015. Therefore, copper in the effluent does not exhibit reasonable potential to cause or contribute to an exceedance of water quality objectives.

#### 4. **WQBEL Calculations**

Final WQBELs have been determined using the methods described in Section 1.4 of the SIP.

**Step 1:** To calculate the effluent limits, an effluent concentration allowance (ECA) is calculated for each pollutant found to have reasonable potential using the following equation, which takes into account dilution and background concentrations:

$$ECA = C + D (C - B),$$

Where:

C = the applicable water quality criterion (adjusted for effluent hardness and expressed as the total recoverable metal, if necessary)

D = dilution credit (here D= 0, as the discharge does not qualify for a dilution credit)

B = background concentration

Here, no credit for dilution is allowed, which results in the ECA being equal to the applicable criterion (ECA = C).

**Step 2:** For each ECA based on an aquatic life criterion/objective (ammonia), the long term average discharge condition (LTA) is determined by multiplying the ECA by a factor (multiplier), which adjusts the ECA to account for effluent variability. The multiplier depends on the coefficient of variation (CV) of the data set and whether it is an acute or

chronic criterion/objective. Table 1 of the SIP provides pre-calculated values for the multipliers based on the values of the CV. When the data set contains less than 10 sample results, or when 80 percent or more of the data set is reported as non-detect (ND), the CV is set equal to 0.6. Derivation of the multipliers is presented in Section 1.4 of the SIP.

The SIP procedure assumes a 4-day averaging period for calculating the LTA. However, U.S. EPA recommends modifying the procedure for calculating permit limits for ammonia using a 30-day averaging period for the calculation of the LTA corresponding to the 30-day CCC. Therefore, while the LTAs corresponding to the acute and 4-day chronic criteria were calculated according to SIP procedures, the LTA for ammonia corresponding to the 30-day CCC was calculated assuming a 30-day averaging period.

From Table 1 of the SIP, the ECA for calculating LTAs at the 99<sup>th</sup> percentile occurrence probability are used in Table F-8 to calculate the LTAs.

**Table F-6. Determination of Long Term Averages**

Pollutant	Units	ECA			ECA Multiplier			LTA		
		Acute	Chronic 4-Day	Chronic 30-Day	Acute	Chronic 4-Day	Chronic 30-Day	Acute	Chronic 4-Day	Chronic 30-Day
Ammonia (as N)	mg/L	9.64	11.07	4.43	0.17	0.32	0.617	1.667	3.54	2.73

**Step 3:** WQBELs, including an AMEL and MDEL, are calculated using the most limiting (lowest) LTA. The LTA is multiplied by a factor that accounts for averaging periods and exceedance frequencies of the effluent limitations, and for the AMEL, the effluent monitoring frequency. Here, the CV is set equal to 1.21 for ammonia, and the sampling frequency is set equal to 4 (n = 4) for the acute criterion and chronic 4-day criterion, and 30 (n = 30) for the chronic 30-day criterion. The 99<sup>th</sup> percentile occurrence probability was used to determine the MDEL multiplier and a 95<sup>th</sup> percentile occurrence probability was used to determine the AMEL multiplier. From Table 2 of the SIP, the MDEL multiplier for ammonia is 5.785. The AMEL multiplier for ammonia is 2.14. Final WQBELs for ammonia is determined as follows.

**Table F-7. Determination of Final WQBELs Based on Aquatic Life Criteria**

Pollutant	Unit	LTA	MDEL Multiplier	AMEL Multiplier	MDEL	AMEL
Ammonia (as N)	mg/L	1.667	5.785	2.14	9.6	3.6

**Step 4:** When the most stringent water quality criterion/objective is a human health criterion/objective (as for dichlorobromomethane, heptachlor epoxide, and nitrate), the AMEL is set equal to the ECA. From Table 2 of the SIP, when CV = 0.6 and n = 4, the MDEL multiplier at the 99<sup>th</sup> percentile occurrence probability equals 3.11, and the AMEL multiplier at the 95<sup>th</sup> percentile occurrence probability equals 1.55 (for dichlorobromomethane, and heptachlor epoxide). For nitrate, the CV = 0.46, the MDEL multiplier at the 99<sup>th</sup> percentile occurrence probability equals 2.54, and the AMEL multiplier at the 95<sup>th</sup> percentile occurrence probability equals 1.42. The MDEL for protection of human health is calculated by multiplying the ECA by the ratio of the MDEL multiplier to the AMEL multiplier. Final WQBELs for dichlorobromomethane, heptachlor epoxide, and nitrate are determined as follows.

**Table F-8. Determination of Final WQBELs Based on Human Health Criteria**

Pollutant	ECA (µg/L)	MDEL/AMEL	MDEL (µg/L)	AMEL (µg/L)
Dichlorobromomethane	0.56	2.0	1.1	0.56
Heptachlor Epoxide	0.0001	2.0	0.0002	0.0001
Nitrate	10	1.8	18	10

A summary of WQBELs established by this Order is given in the table below.

**Table F-9. Summary of Water Quality-Based Effluent Limitations – Discharge Point 001**

Parameter	Units	Effluent Limitations				
		Average Monthly	Average Weekly	Maximum Daily	Instantaneous Minimum	Instantaneous Maximum
pH	s.u.	--	--	--	6.5	8.5
Dichlorobromo-methane	µg/L	0.56	--	1.1	--	--
Heptachlor Epoxide	µg/L	0.0001	--	0.0002	--	--
Settleable Solids	ml/L	0.1	--	0.2	--	--
Total Residual Chlorine	mg/L	0.01	--	0.02	--	--
Ammonia Nitrogen, Total (as N)	mg/L	1.8	--	7.6	--	--
Nitrate	mg/L	10	--	18	--	--
Total Coliform Bacteria	MPN/100 mL	--	23 <sup>1</sup>	--	--	240

**Table Notes:**  
 1. The median value of total coliform bacteria shall not exceed an MPN of 23 per 100 mL, in any 30-day period.

**5. Whole Effluent Toxicity (WET)**

Monitoring and effluent limitations for whole effluent toxicity protect the receiving water from the aggregate effect of a mixture of pollutants that may be present in effluent. There are two types of WET tests – acute and chronic. An acute toxicity test is conducted over a short time period and measures mortality. A chronic test is conducted over a longer period of time and may measure mortality, reproduction, and/or growth.

WET requirements are derived from the CWA and the Basin Plan. The Basin Plan establishes a narrative water quality objective for toxicity that states “*All waters shall be maintained free of toxic substances in concentrations that are toxic to, or that produce detrimental physiological responses in human, plant, or aquatic life.*” Detrimental responses may include, but are not limited to, decreased growth rate, decreased reproductive success of resident or indicator species, and/or significant alterations in population, community ecology, or receiving water biota. For compliance with the Basin Plan’s narrative toxicity objective, this Order requires the Permittee to conduct WET testing for acute and chronic toxicity, as specified in the MRP (Attachment E, section V).

**a. Acute Aquatic Toxicity**

Consistent with Order No. R1-2011-0004, this Order includes an effluent limitation for acute toxicity in accordance with the Basin Plan, which requires that the average survival of test organisms in undiluted effluent for any three consecutive 96-hour bioassay tests be at least 90 percent, with no single test having less than 70 percent survival.

The Order implements federal guidelines (Regions 9 and 10 Guidelines for Implementing Whole Effluent Toxicity Testing Programs) by requiring the Permittee to conduct acute toxicity tests on a fish species and on an invertebrate species to determine the most sensitive species. According to the U.S. EPA manual, *Methods for Estimating the Acute Toxicity of Effluents and Receiving Waters to Freshwater and Marine Organisms* (EPA/600/4-90/-27F), the acceptable vertebrate species for the acute toxicity test are the fathead minnow, *Pimephales promelas* and the rainbow trout, *Oncorhynchus mykiss*. The acceptable invertebrate species for the acute toxicity test are the water flea, *Ceriodaphnia dubia*, *Daphnia magna*, and *D. pulex*. This Order requires the Permittee to conduct a screening test using a vertebrate and invertebrate species. After the screening test is completed, monitoring can be reduced to the most sensitive species. Attachment E of this Order requires quarterly acute WET monitoring.

**b. Chronic Aquatic Toxicity**

The SIP requires the use of short-term chronic toxicity tests to determine compliance with the narrative toxicity objectives for aquatic life in the Basin Plan. The SIP requires that the Permittee demonstrate the presence or absence of chronic toxicity using tests on the fathead minnow, *Pimephales promelas*, the water flea, *Ceriodaphnia dubia*, and the freshwater alga, *Selenastrum capricornutum* (also named *Raphidocelis subcapitata*). Attachment E of this Order requires annual chronic WET monitoring to demonstrate compliance with the narrative toxicity objective.

The Permittee conducted annual chronic toxicity testing using *P. promelas*, *C. dubia*, and *S. capricornutum*. The following table summarizes the chronic toxicity testing results from April 2011 through May 2015.

**Table F-10. Summary of Chronic Toxicity Results**

Date	<i>Pimephales promelas</i>		<i>Ceriodaphnia dubia</i>		<i>Selenastrum capricornutum</i>
	Survival (TUC)	Growth (TUC)	Survival (TUC)	Reproduction (TUC)	Growth (TUC)
April 19, 2011	1	1	1	1	1
February 7, 2012	1	1	--	--	1
March 6, 2012	--	--	1	2	--
March 20, 2012	--	--	1	1.33	--
March 27, 2012	--	--	1	1	--
April 3, 2012	--	--	1	1	--
April 10, 2012	--	--	1	1	--
March 26, 2013	--	--	1	>1.33	--
April 5, 2013	--	--	1	2	--
April 5, 2013	--	--	1	2	--
April 5, 2013	--	--	1	1	--



Date	<i>Pimephales promelas</i>		<i>Ceriodaphnia dubia</i>		<i>Selenastrum capricornutum</i>
	Survival (TUC)	Growth (TUC)	Survival (TUC)	Reproduction (TUC)	Growth (TUC)
April 5, 2013	--	--	1	1	--
April 5, 2013	--	--	1	1	--
April 5, 2013	--	--	1	>1	--
August 7, 2014	1	1	1	1	1
May 5, 2015	1	1	1	1	1
May 5, 2015	--	--	1	1	--

The Permittee conducted a toxicity identification evaluation (TIE) during April 2013 in response to elevated toxicity found during routine annual toxicity monitoring performed in March 2013. Due to elevated toxicity in the effluent, reasonable potential to cause or contribute to an exceedance of the Basin Plan’s narrative toxicity objective for chronic toxicity has been determined and a narrative effluent limitation for chronic toxicity has been established in this Order.

Numeric chronic toxicity effluent limitations have not been included in the Order for consistency with the SIP, which implements narrative toxicity objectives in basin plans and specifies use of a numeric trigger for accelerated monitoring and implementation of a Toxicity Reduction Evaluation (TRE) in the event that persistent toxicity is detected. The SIP contains implementation gaps regarding the appropriate form and implementation of chronic toxicity limits. This has resulted in the petitioning of a NPDES permit in the Los Angeles Region that contained numeric chronic toxicity effluent limitations. To address the petition, the State Water Board adopted WQO 2003-0012 directing its staff to revise the toxicity control provisions in the SIP. The State Water Board states the following in WQO 2003-012, *“In reviewing this petition and receiving comments from numerous interested persons on the propriety of including numeric effluent limitations for chronic toxicity in NPDES permits for publicly-owned treatment works, that discharge to inland waters, we have determined that this issue should be considered in a regulatory setting, in order to allow for full public discussion and deliberation. We intend to modify the SIP to specifically address the issue. We anticipate that review will occur within the next year. We therefore decline to make a determination here regarding the propriety of the final numeric effluent limitations for chronic toxicity contained in these permits.”* The process to revise the SIP is underway. Proposed changes include clarifying the appropriate form of effluent toxicity limits in NPDES permits and general expansion and standardization of toxicity control implementation related to the NPDES permitting process. Since the toxicity control provisions in the SIP are under revision, it is infeasible to develop numeric effluent limitations for chronic toxicity at this time. The SIP revision may require a permit modification to incorporate new statewide toxicity criteria established by the upcoming SIP revision.

This Order includes a reopener that allows the Regional Water Board to reopen the permit and include a numeric chronic toxicity limitation, a revised acute toxicity limitation, and/or a limitation for a specific toxicant identified in the TRE.

To ensure compliance with the narrative effluent limitation and the Basin Plan's narrative toxicity objective, the Permittee is required to conduct annual chronic WET testing at Discharge Point 001, as specified in the MRP (Attachment E, section V). Furthermore, the MRP (Attachment E, section V.C) requires the Permittee to investigate the causes of, and identify and implement corrective actions to reduce or eliminate effluent toxicity. If the discharge demonstrates toxicity with a result of "Fail" in 100 percent effluent, the Permittee is required to initiate a TRE in accordance with an approved TRE work plan. The "Pass/Fail" trigger is not an effluent limitation; it is the toxicity threshold at which the Permittee is required to perform accelerated chronic toxicity monitoring, as well as the threshold to initiate a TRE if a pattern of effluent toxicity has been demonstrated.

**c. Test of Significant Toxicity (TST)**

Order No. R1-2011-0004 established a numeric chronic toxicity trigger of 1.0 TUC = 100/NOEC, using a five-concentration hypothesis test. In 2010, U.S. EPA endorsed the peer-reviewed *Test of Significant Toxicity (TST) two-concentration hypothesis testing approach in National Pollutant Discharge Elimination System Test of Significant Toxicity Implementation Document* (EPA 833-R-10-003, 2010) as an improved hypothesis-testing tool to evaluate data from U.S. EPA's toxicity test methods. The TST hypothesis testing approach more reliably identifies toxicity—in relation to the chronic (0.25 or more) mean response of regulatory management concern—than the NOEC hypothesis-testing approach. The TST hypothesis testing approach more reliably identifies toxicity – in relation to the acute (0.20 or more) mean responses of regulatory management concern – than the No Observed Effect Concentration (NOEC) approach used previously to establish effluent limitations for acute toxicity.

Since the TST approach has not previously been applied for determining reasonable potential or establishing effluent limitations for acute toxicity, this Order does not include effluent limitations for acute toxicity based on the TST approach. However, this Order does require the Permittee to monitor and report results in a manner that will allow the Regional Water Board to conduct an RPA in accordance with the TST approach at the time of the next permit renewal.

The State Water Board is developing a toxicity amendment to the *Water Quality Control Plan for Enclosed Bays and Estuaries of California* that will standardize the regulation of aquatic toxicity for all non-oceanic surface waters. U.S. EPA's TST approach is an essential component of this draft toxicity amendment as it forms the basis for utilizing numeric water quality objectives and acts as the primary means of determining compliance with the proposed effluent limitations.

In a letter dated February 12, 2014, the State Water Board submitted an alternative test process (ATP) request to U.S. EPA Region 9 for the statewide use of a two-concentration toxicity test design when using the TST approach. This two-concentration test design is composed of a single effluent concentration and a control concentration. U.S. EPA approved the ATP request on March 17<sup>th</sup>, 2014. In June 2014, the approval was challenged in court on procedural grounds under the Administrative Procedures Act by the Southern California Alliance of Publicly Owned Treatment Works (SCAP) and the Central Valley Clean Water Association (CVCWA). The U.S. EPA

withdrew the approval and notified State Water Board in a memo dated February 11, 2015.

It is important to note that U.S. EPA's rescission of its approval of the ATP is not based on the substantive TST statistical analysis or the scientific validity of a two-concentration test design. The withdrawal letter also states that currently there is a proposed rulemaking to change the language in the ATP regulations at 40 C.F.R. part 136.

The benefits of requiring the TST in new or amended permits include improving the statistical power of the toxicity test, and simplifying the analysis as compared to the traditional hypothesis statistical approaches or point estimates. The calculations are straightforward and provide a clear pass/fail result. With the withdrawal of the two-concentration test design approval, an NPDES permit can still require the TST for statistical analyses. Toxicity tests shall be run using a multi-concentration tests design in accordance with 40 C.F.R. section 136.3, and the TST shall be utilized with the biological responses from the permitted in-stream waste concentration (IWC) and the control (effluent concentration of zero). However, even with only two of the five concentration biological responses being used, cost savings in the form of time and effort are still realized for the statistical analysis and data interpretation carried out by the Permittee, lab, and permit manager. This Order requires application of TST for statistical analysis of whole effluent toxicity data.

#### **Tests of Significant Toxicity Design**

The TST's null hypothesis for chronic toxicity is:

$H_0$ : Mean response (In-stream Waste Concentration (IWC) in % effluent)  $\leq$  0.75 mean response (control)

Results are analyzed using the TST approach and an acceptable level of chronic toxicity is demonstrated by rejecting the null hypothesis and reporting "Pass" or "P".

The chronic IWC (in % effluent) for Discharge Point 001 is 100%. The chronic toxicity trigger for Discharge Point 001 is expressed as a null hypothesis ( $H_0$ ) and regulatory management decision (b value) of 0.75 for the chronic toxicity methods in the MRP. The null hypothesis for this discharge is:

$H_0$ : Mean response (100% effluent)  $\leq$  0.75 mean response (control)

Results shall be analyzed using the TST hypothesis testing approach in section V.B.6.a of the MRP. Compliance with this chronic toxicity limitation is demonstrated by rejecting the null hypothesis and reporting "Pass" or "P".

When the chronic toxicity test results in a "Fail" or "F," the Permittee must initiate accelerated monitoring as specified in the MRP (Attachment E, section V). After accelerated monitoring, if conditions of chronic toxicity are found to persist, the Permittee will be required to conduct a TRE, as described by the MRP.

Notification requirements for chronic WET testing include a 72-hour verbal notification requirement and a 14 day written report requirement, if test results indicate toxicity. The 14 day written notification is established in the U.S. EPA WET Guidance documents cited in the MRP. The 72-hour verbal notification requirement is being added to

provide the Regional Water Board with knowledge of the toxicity in advance of the written report. The 72-hour requirement is intended to give the Permittee sufficient time to make a telephone call to Regional Water Board staff and accounts for non-working days (e.g., weekends). Verbal notification of WET test exceedances may be left by voice mail if the Regional Water Board staff person is not immediately available by telephone.

This Order includes a requirement for the Permittee to conduct a screening test using at least one vertebrate, invertebrate, and plant species. After the screening test is completed, monitoring can be reduced to the most sensitive species.

This Order also includes a narrative chronic toxicity limitation as required by State Water Board Order No. WQO 2003-012.

#### **D. Final Effluent Limitation Considerations**

##### **1. Anti-Backsliding Requirements**

Sections 402(o) and 303(d)(4) of the CWA and federal regulations at 40 C.F.R. section 122.44(l) prohibit backsliding in NPDES permits. These anti-backsliding provisions require effluent limitations in a reissued permit to be as stringent as those in the previous permit, with some exceptions where limitations may be relaxed. All effluent limitations in this Order are at least as stringent as the effluent limitations in Order No. R1-2011-0004, with the exception of effluent limitations for total coliform and mass-based effluent limitations for BOD<sub>5</sub> and TSS.

Order No. R1-2011-0004 included effluent limitations for total coliform that included a maximum daily effluent limitation of 230 MPN/100 mL. This Order revises the maximum daily total coliform effluent limitation to be 240 MPN/100 mL, based on the title 22 requirements for disinfected secondary treated effluent. The existing coliform effluent limit constitutes a technical mistake in interpretation of the title 22 requirements, which permits the relaxation of effluent limitations consistent with CWA section 402(o)(2)(B)(ii).

Order No. R1-2011-0004 established final mass-based effluent limitations for BOD<sub>5</sub> and TSS. Historically, the Regional Water Board routinely incorporated mass-based limits (in addition to concentration-based limits) for BOD<sub>5</sub> and TSS in NPDES permits to encourage correction of infiltration and inflow (I&I). Applied in this way, mass-based limitations effectively restrict a POTW's wet-weather influent flows to less than or equal to the treatment facility's design capacity in situations where POTW's experience excessive I&I as a result of climate conditions and/or aging infrastructure. The application of mass-based effluent limitations for BOD<sub>5</sub> and TSS is not necessary to limit wet-weather inflow into the Permittee's Facility because I&I is not a significant problem and the Permittee is not in danger of exceeding treatment capacity for reasonably anticipated flows. 40 C.F.R. 133.103(d) states, "...The determination of whether the less concentrated wastewater is the result of excessive I&I will use the definition of excessive I&I in 40 C.F.R. 35.2005(b)(16) plus the additional criterion that inflow is nonexcessive if the total flow to the POTW (i.e., wastewater plus inflow plus infiltration) is less than 275 gallons per capita per day." Using daily flow data from June 1, 2010, through December 31, 2015, the flow per capita (assuming a population of 100) exceeded 275 gallons per day five times out of over 2,000 daily flow measurements. Therefore, I&I is not a significant problem for the Facility.

Mass limitations for BOD<sub>5</sub> and TSS for discharges of treated wastewater have been removed. 40 C.F.R. 122.45(f)(1)(ii) states that mass limitations are not required “*when applicable standards and limitations are expressed in terms of other units of measure.*” Secondary treatment standards for BOD<sub>5</sub> and TSS in 40 C.F.R. 133.102, on which the effluent limitations in previous permits were based, are expressed in concentration and percent removal (i.e., other units of measure).

Elimination of mass-based limitations for these pollutants is not expected to result in an increased pollutant loading to surface waters as recent self-monitoring reports indicate that compliance with concentration-based effluent limitations for BOD<sub>5</sub> and TSS effectively maintain the Permittee’s mass emission rates for BOD<sub>5</sub> and TSS well below permitted mass-based limitations. In addition, even if there is a resulting increase in pollutant loading, there is no evidence that the increase will result in degradation of water quality. Therefore, relaxation of effluent limitations for BOD<sub>5</sub> and TSS in this Order is also permissible under CWA section 402(o)(2)(B), based on new information available to the Regional Water Board.

## **2. Antidegradation Policies**

This Order is consistent with applicable federal and state antidegradation policies, as it does not authorize the discharge of increased concentrations of pollutants or increased volumes of treated wastewater beyond that which was permitted to discharge in accordance with Order No. R1-2011-0004.

## **3. Stringency of Requirements for Individual Pollutants**

This Order contains both technology-based effluent limitations and WQBELs for individual pollutants. The technology-based effluent limitations consist of restrictions on BOD<sub>5</sub> and TSS. Restrictions on these pollutants are discussed in section IV.B of this Fact Sheet. This Order’s technology-based pollutant restrictions implement the minimum, applicable federal technology-based requirements. In addition, this Order contains effluent limitations for ammonia, chlorine residual, dichlorobromomethane, heptachlor epoxide, pH, nitrate, settleable solids, and total coliform bacteria that are more stringent than the minimum, federal technology-based requirements but are necessary to meet water quality standards. These requirements are discussed in section IV.C.3 of the Fact Sheet.

WQBELs have been derived to implement water quality objectives that protect beneficial uses. Both the beneficial uses and the water quality objectives have been approved pursuant to federal law and are the applicable federal water quality standards. Most beneficial uses and water quality objectives contained in the Basin Plan were approved under state law and submitted to and approved by U.S. EPA prior to May 30, 2000. Any water quality objectives and beneficial uses submitted to U.S. EPA prior to May 30, 2000, but not approved by U.S. EPA before that date, are nonetheless “*applicable water quality standards for purposes of the CWA*” pursuant to 40 C.F.R. section 131.21(c)(1). Collectively, this Order’s restrictions on individual pollutants are no more stringent than required to implement the requirements of the CWA.

The Regional Water Board has considered the factors in Water Code section 13263, including the provisions of Water Code section 13241, in establishing these requirements.

## **E. Interim Effluent Limitations**

### **1. Concentration Based Effluent Limitation for Total Ammonia and Total Nitrate.**

Concentration based interim effluent limitations for total ammonia and total nitrate are based on treatment facility performance using the monitoring results at EFF-001 and EFF-003 (monitoring location for discharges to Strongs Creek and to the Eel River) for the period of February 2011 through February 2017. The performance-based interim AMELs for total ammonia and total nitrate are 9.4 mg/L and 32 mg/L respectively.

Performance based effluent limitations for total ammonia were calculated using the methods and concepts described in Appendix E of the USEPA document titled *Technical Support Document for Water Quality-Based Toxics Control*, March 1991. For total ammonia, the upper 95 percentile limit of a lognormal sample distribution was calculated using available data reported as detected and non-detected, and assuming monthly monitoring of the discharge (i.e., n=4). The upper 95 percentile limit of a lognormal sample distribution was calculated using total ammonia data collected by the Permittee during the period of February 2011 through February 2017, and statistical analysis performed in excel (n=53,  $\mu = 2.70$ , s.d. 3.96, CV = 1.47). The 95th percentile limit of 9.4 mg/L was then established for total ammonia as a performance-based AMEL.

Performance based effluent limitation for total nitrate were analyzed and were found to be normally distributed (n = 65,  $\mu = 16.9$ , s.d. =7.61, CV = 0.45). The upper 95 percentile limit of a normal sample distribution was calculated using total nitrate data collected by the Permittee during the period of February 2011 through February 2017, and statistical analysis performed in excel. The 95th percentile limit of 32 mg/L was then established for total nitrate as a performance-based AMEL.

## **F. Land Discharge Specifications and Requirements – Not Applicable**

## **G. Recycling Specifications and Requirements – Not Applicable**

## **H. Other Requirements**

- 1. Residual Chlorine.** This Order eliminates the minimum chlorine residual requirement from Order No. R1-2011-0004. Instead, this Order requires the Permittee to maintain a chlorine residual concentration that ensures the discharge meets the total coliform effluent limitations at the end of the disinfection process so that adequate pathogen reduction is continuously achieved at Discharge Points 001 and 003.

## **V. RATIONALE FOR RECEIVING WATER LIMITATIONS**

### **A. Surface Water**

CWA section 303(a-c) requires states to adopt water quality standards, including criteria where they are necessary to protect beneficial uses. The Regional Water Board adopted water quality criteria as water quality objectives in the Basin Plan. The Basin Plan states that “[t]he numerical and narrative water quality objectives define the least stringent standards that the Regional [Water] Board will apply to regional waters in order to protect the beneficial uses.” The Basin Plan includes numeric and narrative water quality objectives for various beneficial uses and water bodies. This Order contains Receiving Surface Water Limitations based on the Basin Plan numerical and narrative water quality objectives for biostimulatory substances, bacteria, chemical constituents, color, dissolved oxygen, floating material, oil and grease, pH, pesticides,

radioactivity, sediment, settleable material, suspended material, tastes and odors, temperature, toxicity, and turbidity.

**B. Groundwater**

1. The beneficial uses of the underlying groundwater are municipal and domestic supply, industrial service supply, industrial process supply, agricultural supply, and freshwater replenishment to surface waters.
2. Groundwater limitations are required to protect the beneficial uses of the underlying groundwater.
3. Discharges from the Facility shall not cause exceedance of applicable water quality objectives or create adverse impacts to beneficial uses of groundwater.
4. The Basin Plan requires that waters designated for use as MUN shall not contain concentrations of chemical constituents in excess of the limits specified in CCR, title 22, division 4, chapter 15, article 4.1, section 64435, and article 5.5, section 64444.
5. In groundwaters used for domestic or municipal supply (MUN), the collection, treatment, storage, and disposal of wastewater shall not cause the median of the most probable number of coliform organisms over any 7-day period to exceed 1.1 MPN/100 mL or 1 colony/100 mL.

**VI. RATIONALE FOR PROVISIONS**

**A. Standard Provisions**

**1. Federal Standard Provisions**

Standard Provisions, which apply to all NPDES permits in accordance with 40 C.F.R. section 122.41, and additional conditions applicable to specified categories of permits in accordance with 40 C.F.R. section 122.42, are provided in Attachment D to the Order. The Permittee must comply with all standard provisions and with those additional conditions that are applicable under 40 C.F.R. section 122.42. The rationale for the special conditions contained in the Order is provided in section VI.B, below.

Sections 122.41(a)(1) and (b) through (n) of 40 C.F.R. establish conditions that apply to all state-issued NPDES permits. These conditions must be incorporated into the permits either expressly or by reference. If incorporated by reference, a specific citation to the regulations must be included in the Order. Section 123.25(a)(12) allows the state to omit or modify conditions to impose more stringent requirements. In accordance with 40 C.F.R. section 123.25, this Order omits federal conditions that address enforcement authority specified in 40 C.F.R. sections 122.41(j)(5) and (k)(2) because the enforcement authority under the Water Code is more stringent. In lieu of these conditions, this Order incorporates by reference Water Code section 13387(e).

**2. Regional Water Board Standard Provisions**

In addition to the Federal Standard Provisions (Attachment D), the Permittee shall comply with the Regional Water Board Standard Provisions provided in Standard Provisions VI.A.2 of the Order.

- a. Order Provision VI.A.2.a identifies the state's enforcement authority under the Water Code, which is more stringent than the enforcement authority specified in the federal regulations (e.g., 40 C.F.R. sections 122.41(j)(5) and (k)(2)).
- b. Order Provision VI.A.2.b requires the Permittee to notify Regional Water Board staff, orally and in writing, in the event that the Permittee does not comply or will be unable to comply with any Order requirement. This provision requires the Permittee to make direct contact with a Regional Water Board staff person.

## **B. Special Provisions**

### **1. Reopener Provisions**

- a. **Standard Revisions (Special Provision VI.C.1.a).** Conditions that necessitate a major modification of a permit are described in 40 C.F.R. section 122.62, which include the following:
  - i. When standards or regulations on which the permit was based have been changed by promulgation of amended standards or regulations or by judicial decision. Therefore, if revisions of applicable water quality standards are promulgated or approved pursuant to Section 303 of the CWA or amendments thereto, the Regional Water Board will revise and modify this Order in accordance with such revised standards.
  - ii. When new information that was not available at the time of permit issuance would have justified different permit conditions at the time of issuance.
- b. **Reasonable Potential (Special Provision VI.C.1.b).** This provision allows the Regional Water Board to modify, or revoke and reissue, this Order if present or future investigations demonstrate that the Permittee governed by this Permit is causing or contributing to excursions above any applicable priority pollutant criterion or objective, or adversely impacting water quality and/or the beneficial uses of receiving waters.
- c. **Whole Effluent Toxicity (Special Provision VI.C.1.c).** This Order requires the Permittee to investigate the causes of, and identify corrective actions to reduce or eliminate effluent toxicity through a TRE. This Order may be reopened to include a numeric chronic toxicity limitation, new acute toxicity limitation, and/or a limitation for a specific toxicant identified in the TRE.
- d. **303(d)-Listed Pollutants (Special Provision VI.C.1.d).** This provision allows the Regional Water Board to reopen this Order to modify existing effluent limitations or add effluent limitations for pollutants that are the subject of any future TMDL action.
- e. **Water Effects Ratios (WERs) and Metal Translators (Special Provision VI.C.1.e).** This provision allows the Regional Water Board to reopen this Order if future studies undertaken by the Permittee provide new information and justification for applying a WER or metal translator to a water quality objective for one or more priority pollutants.
- f. **Nutrients (Special Provision VI.C.1.f).** This Order contains effluent limitations for ammonia and nitrate and effluent monitoring for nutrients (ammonia, nitrate, and phosphorus). This provision allows the Regional Water Board to reopen this Order if



future monitoring data indicates the need for new or revised effluent limitations for any of these parameters.

## 2. **Special Studies and Additional Monitoring Requirements**

- a. **Ammonia Study (Special Provision VI.C.2.a).** The 2013 Freshwater Criteria for ammonia vary based on pH and temperature, and reflect the latest scientific knowledge on the toxicity of ammonia to freshwater aquatic life, including new data on sensitive freshwater mussels and gill-breathing snails. Under most conditions, the 2013 Freshwater Criteria are more stringent than the 1999 Freshwater Criteria when mussels are present in the receiving water. Adequate information is not available to determine if these freshwater mussels are present in the receiving water. The 2013 Freshwater Criteria document states, *"In the case of ammonia, where a state demonstrates that mussels are not present on a site-specific basis, the recalculation procedure may be used to remove the mussel species from the national criteria dataset to better represent the species present at the site."* The 2013 Freshwater Criteria document contains recalculation procedures for situations where mussels are not present in the receiving water. This Order requires the Permittee to conduct a study to determine the presence of mussels in the receiving water. The Regional Water Board shall use the results of this study to inform the determination of ammonia effluent limitations, if necessary, during the next permit renewal.
- b. **Source Control and Pretreatment Studies (Special Provision VI.C.2.b).** As discussed further in section VI.B.5.b of this Fact Sheet, this Order does not require the Permittee to develop a pretreatment program that conforms to federal regulations. However, in order to prevent interference with the POTW or pass through of pollutants to the receiving water, this Order requires the Permittee to conduct a local limits study and review and update, if necessary, their sewer use ordinances.

## 3. **Best Management Practices and Pollution Prevention**

- a. **Pollutant Minimization Program (Special Provision VI.C.3.a).** This provision is included in this Order pursuant to section 2.4.5 of the SIP. The Regional Water Board includes standard provisions in all NPDES permits requiring development of a Pollutant Minimization Program when there is evidence that a toxic pollutant is present in the effluent at a concentration greater than an applicable effluent limitation.

## 4. **Construction, Operation, and Maintenance Specifications**

- a. **Operation and Maintenance (Special Provisions VI.C.4.a and b).** 40 C.F.R. section 122.41(e) requires proper operation and maintenance of permitted wastewater systems and related facilities to achieve compliance with permit conditions. An up-to-date operation and maintenance manual, as required by Provision VI.C.4.b of this Order, is an integral part of a well-operated and maintained facility.

## 5. **Special Provisions for Municipal Facilities (POTWs Only)**

- a. **Wastewater Collection Systems (Special Provision VI.C.5.a)**
  - i. **Statewide General WDRs for Sanitary Sewer Systems.** On May 2, 2006, the State Water Board adopted General Waste Discharge Requirements for Sanitary Sewer Systems, Water Quality Order No. 2006-0003-DWQ (General SSO Order). The General SSO Order requires public agencies that own or operate sanitary

sewer systems with greater than 1 mile of pipes or sewer lines to enroll for coverage under the General SSO Order. The General SSO Order requires agencies to develop sanitary sewer management plans (SSMPs) and report all SSOs, among other requirements and prohibitions. The Permittee has enrolled under the General SSO Order as required.

On February 20, 2008, the State Water Board adopted Order No. WQ 2008-0002-EXEC Adopting Amended Monitoring and Reporting Requirements for Statewide General Waste Discharge Requirements for Statewide General Waste Discharge Requirements for Sanitary Sewer Systems, to ensure adequate and timely notifications are made to the Regional Water Board and appropriate local, state, and federal authorities in case of sewage spills. On August 6, 2013, the State Water Board adopted Order No. WQ 2013-0058-EXEC Amending Monitoring and Reporting Program for Statewide General Waste Discharge Requirements for Sanitary Sewer Systems. Order No. WQ 2013-0058-EXEC addressing compliance and enforceability of the Monitoring and Reporting Program and superseding the amendments in Order No. WQ-2008-0002-EXEC. Notification and reporting of SSOs is conducted in accordance with the requirements of Order Nos. 2006-0003-DWQ and WQ 2013-0058-EXEC, and any revisions thereto for operation of its wastewater collection system.

**b. Source Control and Pretreatment Provisions (Special Provision VI.C.5.b).**

Pursuant to Special Provision VI.C.5.b.i, the Permittee shall implement the necessary legal authorities to monitor and enforce source control standards, restrict discharges of toxic materials to the collection system, and inspect facilities connected to the system.

40 C.F.R. section 403.8(a) requires POTWs with a total design flow greater than 5 mgd and receiving pollutants which pass through or interfere with the operation of the POTW to establish a POTW Pretreatment Program. The Regional Water Board may also require that a POTW with a design flow of 5 mgd or less develop a POTW Pretreatment Program if the nature or volume of the industrial influent, treatment process upsets, violations of POTW effluent limitations, contamination of municipal sludge, or other circumstances warrant in order to prevent interference or pass through. The Permittee did not report any known industrial wastes subject to regulation under the NPDES Pretreatment Program being discharged to the Facility in Part F of EPA Application Form 2A and the permitted flow of the Facility is less than 5 mgd; therefore, the Order does not require the Permittee to develop a pretreatment program that conforms to federal regulations. However, in order to prevent interference with the POTW or pass through of pollutants to the receiving water, the Order requires the Permittee to conduct an industrial waste survey to identify all non-domestic facilities in the service area that might discharge pollutants that could pass through or interfere with the operation or performance of the Facility and to monitor the influent for priority pollutants. If the results of the industrial waste survey or influent monitoring indicate that a pretreatment program is necessary, pursuant to 40 C.F.R. section 403.8(3), the Regional Water Board may reopen this permit to require the Permittee to develop a pretreatment program. Additionally, section VI.C.2.b of this Order requires the Permittee to conduct a local limits study and review and update, if necessary, their sewer use ordinances.

Water Code section 13263.3(d)(1) allows the Regional Water Board to require a discharger to complete and implement a pollution prevention plan if pollution prevention is necessary to achieve a water quality objective, to include, pursuant to Water Code section 13263.3(d)(3), an analysis of the methods that could be used to prevent the discharge of the pollutants into the POTW. These methods can include application of local limits to industrial or commercial dischargers, pollution prevention techniques, public education and outreach, or other innovative and alternative approaches to reduce discharges of pollutants to the POTW. The analysis also shall identify sources, or potential sources, not within the ability or authority of the POTW to control, such as pollutants in the potable water supply, airborne pollutants, pharmaceuticals, or pesticides, and estimate the magnitude of those sources, to the extent feasible. This Order includes requirements for the Permittee to implement a source identification and reduction program.

A key component of an effective source control program is the identification and location of possible industrial users within the POTW's wastewater collection system. This information is typically obtained by the POTW through industrial waste surveys. The following types of resources can be consulted in compiling a master list of industrial users:

- i. Water and sewer billing records
- ii. Applications for sewer service
- iii. Local telephone directories
- iv. Chamber of Commerce and local business directories
- v. Business license records
- vi. POTW and wastewater collection personnel and field observations
- vii. Business associations
- viii. The internet
- ix. Industrial and non-residential sewer use permit records

In addition, the Regional Water Board recognizes that some form of source control is prudent to ensure the efficient operation of the Facility, the safety of Facility staff, and to ensure that pollutants do not pass through the treatment Facility to impair the beneficial uses of the receiving water. The proposed Order includes prohibitions for the discharge of pollutants that may interfere, pass through, or be incompatible with treatment operations, interfere with the use of disposal of sludge, or pose a health hazard to personnel.

- c. **Sludge Disposal and Handling Requirements (Special Provision VI.C.5.c).** The disposal or reuse of wastewater treatment screenings, sludges, or other solids removed from the liquid waste stream is regulated by 40 C.F.R. parts 257, 258, 501, and 503, and the State Water Board promulgated provisions of title 27 of the CCR. All solids are composted to exceptional quality class requirements for re-use as a soil amendment.
- d. **Biosolids Management (Special Provision VI.C.5.d).** This provision requires the Permittee to comply with the State's regulations relating to the discharge of biosolids

to the land. The discharge of biosolids through land application is not regulated under this Order. The Permittee is required to obtain coverage under the State Water Board Order No. 2004-0012-DWQ, General Waste Discharge Requirements for the Discharge of Biosolids to Land as a Soil Amendment in Agricultural, Silvicultural, Horticultural, and Land Reclamation Activities (General Biosolids Order). Coverage under the General Biosolids Order, as opposed to coverage under this NPDES permit or individual WDRs, implements a consistent statewide approach to regulating this waste discharge. The Permittee is currently registered as an official compost facility.

- e. **Operator Certification (Special Provision VI.C.5.e).** This provision requires the Facility to be operated by supervisors and operators who are certified as required by title 23, section 3680 of the CCR.
- f. **Adequate Capacity (Special Provision VI.C.5.f).** The goal of this provision is to ensure appropriate and timely planning by the Permittee to ensure adequate capacity for the protection of public health and water quality.

#### 6. Other Special Provisions

- a. **Storm Water (Special Provision VI.C.6.a).** For the control of storm water discharge from the Facility, if required, the Permittee shall seek separate authorization to discharge under the requirements of the State Water Board's Water Quality Order No. 2014-0057-DWQ, NPDES General Permit No. CAS000001, General Permit for Storm Water Discharges Associated with Industrial Activities (or subsequent renewed versions of the NPDES General Permit CAS000001), which is not incorporated by reference in this Order.

#### 7. Compliance Schedules – Special Provision VI.C.7)

The Order includes a compliance schedule for the Permittee to achieve compliance with final effluent limitations for total ammonia and total nitrate. The compliance schedule is needed because the Order includes final effluent limitations for total ammonia and total nitrate that will require the Permittee to implement actions, such as designing and constructing facilities or implementing new or significantly expanded programs and securing financing to comply with the new, more stringent permit limitations that are included in the Order.

The compliance schedule is in accordance with the State Water Board Compliance Schedule Policy based on the Permittee providing written documentation demonstrating that it needs additional time to complete tasks needed to comply with the more stringent final total ammonia and total nitrate limitations. The Permittee needs time to complete an assessment to determine the most appropriate way to comply with the final effluent limitations, followed by time to design facilities and/or develop a program and secure financing. The Permittee requested seven years to achieve full compliance. Regional Water Board staff determined that the Permittee should be able to complete the proposed tasks in a period of seven years. The compliance schedule provides seven years for the Permittee to achieve compliance with the final effluent limitation for total ammonia and total nitrate and includes interim effluent limitations and interim compliance dates that do not exceed one year.

In order to meet new, more stringent ammonia and nitrate effluent limitations, the Permittee will need to upgrade the treatment processes at the Facility to achieve proper nitrification and denitrification. The Permittee has made diligent efforts to address the discharge. The Permittee has received a \$500,000 Proposition 1 Small Community

Wastewater Planning Grant (Grant) to investigate treatment alternatives for compliance with final effluent limitations for ammonia and nitrate. The Grant will allow the Permittee to develop plans to construct a preferred alternative that will meet the final effluent limitations for ammonia and nitrate. Task 4 of the compliance schedule in this permit requires the Permittee to secure funding for construction of the preferred alternative. The Permittee has submitted the required documentation as specified in paragraph four of the Compliance Schedule Policy and this compliance schedule will bring the Permittee back into compliance in the shortest time possible. The tasks and interim dates identified in the compliance schedule ensure that the Permittee will attain the highest discharge quality that can be reasonably achieved until final compliance is attained.

## **VII. RATIONALE FOR MONITORING AND REPORTING REQUIREMENTS**

Section 122.48 of 40 C.F.R. requires that all NPDES permits specify requirements for recording and reporting monitoring results. Water Code section 13383 authorizes the Regional Water Board to require technical and monitoring reports. The MRP, Attachment E, establishes monitoring and reporting requirements that implement federal and state requirements. The following provides the rationale for the monitoring and reporting requirements contained in the MRP for this Facility.

### **A. Influent Monitoring**

1. Influent monitoring requirements at Monitoring Location INF-001 for BOD<sub>5</sub> and TSS are retained from Order No. R1-2011-0004 and are necessary to determine compliance with the Order's 85 percent removal requirement for these parameters.
2. Influent monitoring requirements for flow at Monitoring Locations INF-001 are retained from Order No. R1-2011-0004.

### **B. Effluent Monitoring**

1. Effluent monitoring requirements are necessary to determine compliance with prohibitions and/or effluent limitations established by the Order. Monitoring at Monitoring Location EFF-001 is necessary to demonstrate compliance with effluent limitations and demonstrate whether or not the discharge poses reasonable potential for a pollutant to exceed any numeric or narrative water quality objectives.
  - a. Effluent monitoring frequencies and sample types for flow, BOD<sub>5</sub>, TSS, pH, total coliform bacteria, settleable solids, chlorine residual, chlorodibromomethane, dichlorobromomethane, ammonia (total), ammonia (unionized), nitrate, and phosphorus have been retained from Order No. R1-2011-0004 to determine compliance with effluent limitations, where applicable, and characterize the effluent.
  - b. Monitoring data collected over the term of Order No. R1-2011-0004 demonstrated that the discharge exhibits reasonable potential to cause or contribute to an exceedance of water quality criteria for nitrate and heptachlor epoxide, and this Order establishes new effluent limitations for nitrate and heptachlor epoxide at Discharge Point 001. Therefore, this Order establishes monthly monitoring requirements for heptachlor epoxide at Monitoring Location EFF-001 to determine compliance with the applicable effluent limitations.
  - c. Effluent monitoring has been established for hardness and temperature to characterize the effluent and ensure data for the next permit renewal.

- d. Effluent monitoring requirements for the CTR priority pollutants has been retained from Order No. R1-2011-0004 and increased to twice per permit term at Monitoring Location EFF-001. The increase in monitoring from once per permit term to twice per permit term is necessary to generate adequate data to perform reasonable potential analysis in future permits.
- e. This Order establishes a new monitoring requirement for aluminum in order to gather data needed to evaluate reasonable potential for aluminum. As previously described in section III.D of this Fact Sheet, the Lower Eel River is listed on the U.S. EPA 303(d) list as impaired for aluminum.
- f. The effluent monitoring frequency and sample type for chlorine residual has been changed from a daily grab sample to continuous monitoring with a meter. Regional Water Board staff has identified the need for the Permittee to improve its management of the chlorination process in light of the high levels of chlorine disinfection by-products found in effluent samples. Section IV.D of the Order requires the Permittee to establish continuous chlorine residual monitoring at EFF-001 and EFF-003 by May 1, 2019, in order to demonstrate that the appropriate chlorine residual concentration is maintained in the effluent at EFF-001 and EFF-003 at all times.

**C. Whole Effluent Toxicity Testing Requirements**

- 1. Whole effluent toxicity (WET) monitoring requirements are retained from Order No. R1-2011-0004 and are included in this Order to protect the receiving water quality from the aggregate effect of a mixture of pollutants in the effluent.
- 2. Acute toxicity testing measures mortality in 100 percent effluent over a short test period and chronic toxicity testing is conducted over a longer time period and may measure mortality, reproduction, and/or growth.
- 3. In addition to routine toxicity monitoring, this Order requires the Permittee to maintain and update their TRE Work Plan, in accordance with appropriate U.S. EPA guidance to ensure that the Permittee has a plan to immediately move forward with the initial tiers of a TRE in the event effluent toxicity is encountered in the future. The TRE is initiated by evidence of a pattern of toxicity demonstrated through the additional effluent monitoring provided as a result of an accelerated monitoring program.

**D. Receiving Water Monitoring**

**1. Surface Water**

- a. Receiving water monitoring is required to demonstrate compliance with the Receiving Water Limitations.
- b. Monitoring requirements at Monitoring Location RSW-001 for pH, temperature, dissolved oxygen, electrical conductivity, total dissolved solids, turbidity, floatables/discoloration, hardness, and priority pollutants have been retained from Order No. R1-2011-0004.
- c. Monitoring Requirements at Monitoring Location RSW-002 for pH, temperature, dissolved oxygen, electrical conductivity, total dissolved solids, turbidity, and floatables/discoloration have been retained from Order No. R1-2011-0004.

- d. This Order establishes new receiving water monitoring requirements for aluminum in order to gather data needed to evaluate reasonable potential for aluminum. As previously described in section III.D of this Fact Sheet, the Lower Eel River is listed on the U.S. EPA 303(d) list as impaired for aluminum, and the Permittee uses an aluminum-based polymer in the Facility.

## 2. Groundwater – Not Applicable

This Order does not require groundwater monitoring at this time.

## E. Other Monitoring Requirements

1. **Monitoring Location INT-001.** Internal monitoring at the end of the chlorine contact chamber is required to measure chlorine residual in lieu of daily coliform monitoring to assure adequate disinfection on a daily basis. Section IV.D of the Order requires the Permittee to establish continuous chlorine residual monitoring at INT-001 by May 1, 2019, in order to demonstrate that the appropriate chlorine residual concentration is maintained in the effluent at INT-001 at all times.
2. **Visual Monitoring.** Visual monitoring requirements are retained from the previous Order and are necessary to ensure compliance with receiving water limitations in section V. of the Order.
3. **Sludge Monitoring.** Sludge monitoring requirements at Monitoring Location BIO-001 serve as a basis for the Permittee to develop the Sludge Handling and Disposal Report that is required as part of the Annual Report pursuant to section X.D.2.g of the MRP.
4. **Discharge Monitoring Report Quality Assurance (DMR-QA) Study Program.** Under the authority of section 308 of the CWA (33 U.S.C. § 1318), U.S. EPA requires major permittees under the NPDES Program to participate in the annual DMR-QA Study Program. The DMR-QA Study evaluates the analytical ability of laboratories that routinely perform or support self-monitoring analyses required by NPDES permits. There are two options to satisfy the requirements of the DMR-QA Study Program: (1) The Permittee can obtain and analyze a DMR-QA sample as part of the DMR-QA Study; or (2) Per the waiver issued by U.S. EPA to the State Water Board, the Permittee can submit the results of the most recent Water Pollution Performance Evaluation Study from its own laboratories or its contract laboratories. A Water Pollution Performance Evaluation Study is similar to the DMR-QA Study. Thus, it also evaluates a laboratory's ability to analyze wastewater samples to produce quality data that ensure the integrity of the NPDES Program. The Permittee shall ensure that the results of the DMR-QA Study or the results of the most recent Water Pollution Performance Evaluation Study are submitted annually to the State Water Board. The State Water Board's Quality Assurance Program Officer will send the DMR-QA Study results or the results of the most recent Water Pollution Performance Evaluation Study to U.S. EPA's DMR-QA Coordinator and Quality Assurance Manager.
5. **Accelerated Monitoring Requirements.** Table E-4 includes accelerated monitoring requirements for parameters that are required to be monitored daily, weekly, monthly, and annually.
6. **Flow Monitoring.** Section I.D of the MRP requires proper installation, calibration, operation, and maintenance of flow metering devices.

7. **Spill Notification.** The MRP that is part of this Order establishes requirements for reporting spills and unauthorized discharges, with the exception of SSOs which must be reported in accordance with the requirements of State Water Board Order No. 2006-0003-DWQ and WQ 2013-0058-EXEC.

## VIII. PUBLIC PARTICIPATION

The California Regional Water Quality Control Board, North Coast Region (Regional Water Board) is considering the issuance of waste discharge requirements (WDRs) that will serve as a National Pollutant Discharge Elimination System (NPDES) permit for City of Fortuna Municipal Wastewater Treatment Plant. As a step in the WDR adoption process, the Regional Water Board staff has developed tentative WDRs. The Regional Water Board encourages public participation in the WDR adoption process.

### A. Notification of Interested Parties

The Regional Water Board notified the Permittee and interested agencies and persons twice of its intent to prescribe waste discharge requirements for the discharge and provided an opportunity to submit written comments and recommendations. Notification was provided through the following posting on the Regional Water Board's Internet site at: [http://www.waterboards.ca.gov/northcoast/public\\_notices/public\\_hearings/npdes\\_permits\\_and\\_wdrs.shtml](http://www.waterboards.ca.gov/northcoast/public_notices/public_hearings/npdes_permits_and_wdrs.shtml) and through publication in the Press Democrat and the Eureka Times Standard first on November 18, 2016, and then again on May 6, 2017.

### B. Written Comments

Interested persons were invited to submit written comments concerning these tentative WDRs as provided through the notification process. Comments were due to the Regional Water Board Executive Office electronically via e-mail to [NorthCoast@waterboards.ca.gov](mailto:NorthCoast@waterboards.ca.gov) or on disk (CD or DCD) in Portable Document Format (PDF) file in lieu of paper-sourced documents. The guidelines for electronic submittal of documents can be found on the Regional Water Board website at <http://www.waterboards.ca.gov/northcoast>.

To be fully responded to by staff and considered by the Regional Water Board, the written comments were due at the Regional Water Board office by 5:00 p.m. on **June 6, 2017**.

### C. Public Hearing

The Regional Water Board will hold a public hearing on the draft WDRs during its regular Board meeting on the following date and time and at the following location:

Date: **August 17, 2017**  
Time: 8:30 a.m. or as announced in the Regional Water Board's agenda  
Location: Regional Water Board Hearing Room  
5550 Skylane Boulevard, Suite A  
Santa Rosa, CA 95403

Interested persons were invited to attend. At the public hearing, the Regional Water Board heard testimony pertinent to the discharge, WDRs, and permit. For accuracy of the record, important testimony was requested in writing.



Please be aware that dates and venues may change. Our Web address is <http://www.waterboards.ca.gov/northcoast> where you can access the current agenda for changes in dates and locations.

**D. Waste Discharge Requirements Petitions**

Any aggrieved person may petition the State Water Board to review the decision of the Regional Water Board regarding the final WDRs. The petition must be received by the State Water Board at the following address within 30 calendar days of the Regional Water Board's action:

State Water Resources Control Board  
Office of Chief Counsel  
P.O. Box 100, 1001 I Street  
Sacramento, CA 95812-0100

For instruction on how to file a petition for review see [http://www.waterboards.ca.gov/public\\_notices/petitions/water\\_quality/wqpetition\\_instr.shtml](http://www.waterboards.ca.gov/public_notices/petitions/water_quality/wqpetition_instr.shtml)

**E. Information and Copying**

The Report of Waste Discharge (ROWD), related documents, tentative effluent limitations and special provisions, comments received, and other information are on file and may be inspected at the address identified in section VIII.C, above, at any time between 8:30 a.m. and 4:45 p.m., Monday through Friday. Copying of documents may be arranged through the Regional Water Board by calling (707) 576-2220.

**F. Register of Interested Persons**

Any person interested in being placed on the mailing list for information regarding the WDRs and NPDES permit should contact the Regional Water Board, reference this facility, and provide a name, address, and phone number.

**G. Additional Information**

Requests for additional information or questions regarding this order should be directed to Justin McSmith at [Justin.Smith@waterboards.ca.gov](mailto:Justin.Smith@waterboards.ca.gov) or (707) 576-2082.

**Attachment F-1 – City of Fortuna RPA Summary**

Constituent	Units	Qualifier	MEC	Qualifier	B	C	CMC	CCC	Water & Org	Org. Only	MCL	Reasonable Potential
Antimony	µg/L	--	0.113	--	0.104	6.0	--	--	14	--	6	No
Arsenic	µg/L	<	0.386	<	0.386	10	340	150	--	--	10	No
Beryllium	µg/L	<	0.29	<	0.29	4.0	--	--	--	--	4.0	No
Cadmium	µg/L	<	0.128	<	0.128	1.6	2.35	1.6	--	--	5.0	No
Chromium (III)	µg/L	--	--	--	--	129	1080	129	--	--	--	No
Chromium (VI)	µg/L	<	0.402	--	7.61	11	16	11	--	--	50	No
Copper	µg/L	--	16	--	4.9	26.3	38	26.3	1,300	--	--	No
Lead	µg/L	--	0.176	--	1.25	1.5	39	1.52	--	--	--	No
Mercury	µg/L	<	0.0321	<	0.0321	0.050	--	--	0.050	--	2.0	No
Nickel	µg/L	--	3.17	--	13.3	32	287	32	610	--	100	No
Selenium	µg/L	--	0.23	<	0.168	5.0	--	5.0	--	--	50	No
Silver	µg/L	<	0.111	<	0.111	1.5	1.5	--	--	--	--	No
Thallium	µg/L	<	0.101	<	0.101	1.7	--	--	1.7	--	2.0	No
Zinc	µg/L	--	24.2	--	12.5	73	73.3	73.3	--	--	--	No
Cyanide	µg/L	<	1.2	<	1.2	5.2	22	5.2	700	--	150	No
Asbestos	MFL	<	0.98	--	3.0	7.0	--	--	7	--	7.0	No
2,3,7,8 TCDD	µg/L	<	2.2x10 <sup>-7</sup>	<	5.0x10 <sup>-7</sup>	1.3x10 <sup>-8</sup>	--	--	1.3x10 <sup>-8</sup>	--	3.0x10 <sup>-5</sup>	No
Acrolein	µg/L	<	0.71	<	0.71	320	--	--	320	--	--	No
Acrylonitrile	µg/L	<	0.19	<	0.19	0.06	--	--	0.059	--	--	No
Benzene	µg/L	<	0.28	<	0.28	1.0	--	--	1.2	--	1.0	No
Bromoform	µg/L	<	0.24	<	0.24	4.3	--	--	4.3	--	--	No
Carbon Tetrachloride	µg/L	<	0.44	<	0.50	0.25	--	--	0.25	--	0.5	No
Chlorobenzene	µg/L	<	0.20	<	0.20	70	--	--	680	--	70	No
Chlorodibromomethane	µg/L	<	0.50	--	--	0.40	--	--	0.401	--	--	Yes <sup>1</sup>
Chloroethane	µg/L	<	0.13	<	0.10	No Criteria	--	--	--	--	--	No
2-Chloroethylvinyl ether	µg/L	--	--	--	--	No Criteria	--	--	--	--	--	No
Chloroform	µg/L	<	0.33	<	0.33	No Criteria	--	--	--	--	--	No
Dichlorobromomethane	µg/L	--	2.5	--	--	0.56	--	--	0.56	--	--	Yes

Constituent	Units	Qualifier	MEC	Qualifier	B	C	CMC	CCC	Water & Org	Org. Only	MCL	Reasonable Potential
1,1-Dichloroethane	µg/L	<	0.29	<	0.29	5.0	--	--	--	--	5.0	No
1,2-Dichloroethane	µg/L	<	0.50	<	0.50	0.38	--	--	0.38	--	0.5	No
1,1-Dichloroethylene	µg/L	<	0.50	--	--	0.057	--	--	0.057	--	6.0	No
1,2-Dichloropropane	µg/L	<	0.25	<	0.25	0.52	--	--	0.52	--	5.0	No
1,3-Dichloropropylene	µg/L	<	0.50	--	--	0.50	--	--	10	--	0.5	No
Ethylbenzene	µg/L	<	0.20	<	0.20	300	--	--	3,100	--	300	No
Methyl Bromide	µg/L	<	0.50	--	--	48	--	--	48	--	--	No
Methyl Chloride	µg/L	<	0.15	<	0.15	No Criteria	--	--	--	--	--	No
Methylene Chloride	µg/L	<	0.14	<	0.50	4.7	--	--	4.7	--	5.0	No
1,1,2,2-Tetrachloroethane	µg/L	<	0.16	<	0.50	0.17	--	--	0.17	--	1.0	No
Tetrachloroethylene	µg/L	<	0.50	--	--	0.80	--	--	0.8	--	5.0	No
Toluene	µg/L	--	0.68	<	0.50	150	--	--	6,800	--	150	No
1,2-Trans-Dichloroethylene	µg/L	<	0.17	<	0.17	10	--	--	700	--	10	No
1,1,1-Trichloroethane	µg/L	<	0.31	<	0.31	200	--	--	--	--	200	No
1,1,2-Trichloroethane	µg/L	<	0.21	<	0.21	0.60	--	--	0.60	--	5.0	No
Trichloroethylene	µg/L	<	0.50	--	--	2.7	--	--	2.7	--	5.0	No
Vinyl Chloride	µg/L	<	0.07	<	0.07	0.50	--	--	2.0	--	0.5	No
2-Chlorophenol	µg/L	<	0.53	<	0.53	120	--	--	120	--	--	No
2,4-Dichlorophenol	µg/L	<	0.70	<	0.70	93	--	--	93	--	--	No
2,4-Dimethylphenol	µg/L	<	0.59	<	0.59	540	--	--	540	--	--	No
2-Methyl- 4,6-Dinitrophenol	µg/L	<	0.50	<	0.74	13	--	--	13.4	--	--	No
2,4-Dinitrophenol	µg/L	<	0.51	<	0.51	70	--	--	70	--	--	No
2-Nitrophenol	µg/L	<	0.50	<	0.50	No Criteria	--	--	--	--	--	No
4-Nitrophenol	µg/L	<	0.50	<	0.55	No Criteria	--	--	--	--	--	No
3-Methyl 4-Chlorophenol	µg/L	<	0.50	<	0.67	No Criteria	--	--	--	--	--	No
Pentachlorophenol	µg/L	<	0.97	<	0.97	0.28	6.0	5.0	0.28	--	1.0	No
Phenol	µg/L	<	0.50	<	0.50	21,000	--	--	21,000	--	--	No

Constituent	Units	Qualifier	MEC	Qualifier	B	C	CMC	CCC	Water & Org	Org. Only	MCL	Reasonable Potential
2,4,6-Trichlorophenol	µg/L	<	0.71	<	0.71	2.1	--	--	2.1	--	--	No
Acenaphthene	µg/L	<	0.27	<	0.27	1,200	--	--	1,200	--	--	No
Acenaphthylene	µg/L	<	0.011	<	0.011	No Criteria	--	--	--	--	--	No
Anthracene	µg/L	<	0.029	<	0.029	9,600	--	--	9,600	--	--	No
Benzidine	µg/L	<	0.55	<	0.50	0.00012	--	--	0.00012	--	--	No
Benzo(a)Anthracene	µg/L	<	0.023	<	0.023	0.0044	--	--	0.0044	--	--	No
Benzo(a)Pyrene	µg/L	<	0.03	<	0.03	0.0044	--	--	0.0044	--	0.2	No
Benzo(b)Fluoranthene	µg/L	<	0.30	<	0.03	0.0044	--	--	0.0044	--	--	No
Benzo(ghi)Perylene	µg/L	<	0.029	<	0.029	No Criteria	--	--	--	--	--	No
Benzo(k)Fluoranthene	µg/L	<	0.029	<	0.029	0.0044	--	--	0.0044	--	--	No
Bis(2-Chloroethoxy)Methane	µg/L	<	0.50	<	0.55	No Criteria	--	--	--	--	--	No
Bis(2-Chloroethyl)Ether	µg/L	<	0.50	<	0.50	0.031	--	--	0.031	--	--	No
Bis(2-Chloroisopropyl)Ether	µg/L	<	0.50	<	0.50	1,400	--	--	1,400	--	--	No
Bis(2-Ethylhexyl)Phthalate	µg/L	<	0.65	<	0.65	1.8	--	--	1.8	--	4.0	No
4-Bromophenyl Phenyl Ether	µg/L	<	0.67	<	0.50	No Criteria	--	--	--	--	--	No
Butylbenzyl Phthalate	µg/L	<	1.2	<	1.2	3,000	--	--	3,000	--	--	No
2-Chloronaphthalene	µg/L	<	0.50	<	0.50	1,700	--	--	1,700	--	--	No
4-Chlorophenyl Phenyl Ether	µg/L	<	0.55	<	0.50	No Criteria	--	--	--	--	--	No
Chrysene	µg/L	<	0.028	<	0.028	0.0044	--	--	0.0044	--	--	No
Dibenzo(a,h)Anthracene	µg/L	<	0.027	<	0.027	0.0044	--	--	0.0044	--	--	No
1,2-Dichlorobenzene	µg/L	<	0.50	<	0.50	600	--	--	2,700	--	600	No
1,3-Dichlorobenzene	µg/L	<	0.18	<	0.18	400	--	--	400	--	--	No
1,4-Dichlorobenzene	µg/L	<	0.23	<	0.23	5.0	--	--	400	--	5.0	No
3,3 Dichlorobenzidine	µg/L	<	0.74	<	0.50	0.04	--	--	0.04	--	--	No
Diethyl Phthalate	µg/L	<	0.54	<	0.54	23,000	--	--	23,000	--	--	No
Dimethyl Phthalate	µg/L	<	1.1	<	1.1	313,000	--	--	313,000	--	--	No

Constituent	Units	Qualifier	MEC	Qualifier	B	C	CMC	CCC	Water & Org	Org. Only	MCL	Reasonable Potential
Di-n-Butyl Phthalate	µg/L	<	0.73	<	0.73	2,7000	--	--	2,700	--	--	No
2,4-Dinitrotoluene	µg/L	<	0.59	<	0.59	0.11	--	--	0.11	--	--	No
2,6-Dinitrotoluene	µg/L	<	0.77	<	0.77	No Criteria	--	--	--	--	--	No
Di-n-Octyl Phthalate	µg/L	<	0.72	<	0.72	No Criteria	--	--	--	--	--	No
1,2-Diphenylhydrazine	µg/L	<	0.50	<	0.50	0.04	--	--	0.04	--	--	No
Fluoranthene	µg/L	<	0.033	<	0.03	300	--	--	300	--	--	No
Fluorene	µg/L	<	0.15	<	0.15	1,300	--	--	1,300	--	--	No
Hexachlorobenzene	µg/L	<	0.50	<	0.50	0.00075	--	--	0.00075	--	1.0	No
Hexachlorobutadiene	µg/L	--	--	--	--	0.44	--	--	0.44	--	--	No
Hexachlorocyclopentadiene	µg/L	<	0.50	<	0.50	50	--	--	240	--	50	No
Hexachloroethane	µg/L	<	0.050	<	0.050	1.9	--	--	1.9	--	--	No
Indeno(1,2,3-cd)Pyrene	µg/L	<	0.038	<	0.035	0.0044	--	--	0.0044	--	--	No
Isophorone	µg/L	<	0.55	<	0.55	8.4	--	--	8.4	--	--	No
Naphthalene	µg/L	<	0.018	<	0.018	No Criteria	--	--	--	--	--	No
Nitrobenzene	µg/L	<	0.52	<	0.52	17	--	--	17	--	--	No
N-Nitrosodimethylamine	µg/L	<	0.50	<	0.50	0.00069	--	--	0.00069	--	--	No
N-Nitrosodi-n-Propylamine	µg/L	<	0.50	<	0.50	0.005	--	--	0.005	--	--	No
N-Nitrosodiphenylamine	µg/L	<	0.71	<	0.71	5.0	--	--	5.0	--	--	No
Phenanthrene	µg/L	<	0.012	<	0.012	No Criteria	--	--	--	--	--	No
Pyrene	µg/L	<	0.04	<	0.04	960	--	--	960	--	--	No
1,2,4-Trichlorobenzene	µg/L	--	--	--	--	5.0	--	--	--	--	5.0	No
Aldrin	µg/L	<	0.0016	<	0.0016	0.00013	3.0	--	0.00013	--	--	No
alpha-BHC	µg/L	<	0.0016	<	0.0016	0.0039	--	--	0.0039	--	--	No
beta-BHC	µg/L	<	0.0018	<	0.0018	0.014	--	--	0.014	--	--	No
gamma-BHC	µg/L	<	0.0014	<	0.0014	0.019	0.95	--	0.019	--	0.2	No
delta-BHC	µg/L	<	0.0014	<	0.0014	No Criteria	--	--	--	--	--	No

Constituent	Units	Qualifier	MEC	Qualifier	B	C	CMC	CCC	Water & Org	Org. Only	MCL	Reasonable Potential
Chlordane	µg/L	<	0.034	<	0.034	0.00057	2.4	0.0043	0.00057	--	0.1	No
4,4'-DDT	µg/L	<	0.001	<	0.001	0.00059	1.1	0.001	0.00059	--	--	No
4,4'-DDE	µg/L	<	0.002	<	0.002	0.00059	--	--	0.00059	--	--	No
4,4'-DDD	µg/L	<	0.0099	<	0.0099	0.00083	--	--	0.00083	--	--	No
Dieldrin	µg/L	<	0.0018	<	0.0018	0.00014	0.24	0.056	0.00014	--	--	No
alpha-Endosulfan	µg/L	<	0.0017	<	0.0017	0.056	0.22	0.056	110	--	--	No
beta-Endosulfan	µg/L	<	0.00092	<	0.0092	0.056	0.22	0.056	110	--	--	No
Endosulfan Sulfate	µg/L	--	0.027	<	0.0023	110	--	--	110	--	--	No
Endrin	µg/L	<	0.0019	<	0.0019	0.036	0.086	0.036	0.76	--	2.0	No
Endrin Aldehyde	µg/L	<	0.002	<	0.002	0.76	--	--	0.76	--	--	No
Heptachlor	µg/L	<	0.0018	<	0.0018	0.00021	0.52	0.0038	0.00021	--	0.01	No
Heptachlor Epoxide	µg/L	--	0.012	--	0.013	0.0001	0.52	0.0038	0.0001	--	0.01	Yes
PCBs sum	µg/L	<	0.50	<	0.50	0.00017	--	0.014	0.00017	--	0.5	No
Toxaphene	µg/L	<	0.052	<	0.052	0.0002	0.73	0.0002	0.00073	--	3.0	No
Nitrate, Total (as N)	µg/L	--	33	--	--	10	--	--	--	--	10	Yes

<sup>1</sup> See section IV.C.3 of the Fact Sheet for a discussion of the RPA results for chlorodibromomethane.