

202



Short-Term Methods For Estimating The Chronic Toxicity Of Effluents And Receiving Water To Marine And Estuarine Organisms

Second Edition



**SHORT-TERM METHODS FOR ESTIMATING THE CHRONIC TOXICITY OF EFFLUENTS
AND RECEIVING WATERS TO MARINE AND ESTUARINE ORGANISMS**

(Second Edition)

Edited by

Donald J. Klemm¹ and George E. Morrison²
Teresa J. Norberg-King³, William H. Peltier⁴
and Margarete A. Heber⁵

- ¹Environmental Monitoring Systems Laboratory, Cincinnati, Ohio
²Environmental Research Laboratory, Narragansett, Rhode Island
³Environmental Research Laboratory, Duluth, Minnesota
⁴Environmental Services Division, Athens, Georgia
⁵Office of Water, Washington, D.C.

ENVIRONMENTAL MONITORING SYSTEMS LABORATORY-CINCINNATI
OFFICE OF RESEARCH AND DEVELOPMENT
U.S. ENVIRONMENTAL PROTECTION AGENCY
CINCINNATI, OHIO 45268

DISCLAIMER

This document has been reviewed by the Environmental Monitoring Systems Laboratory-Cincinnati (EMSL-Cincinnati), U. S. Environmental Protection Agency (USEPA), and approved for publication. The mention of trade names or commercial products does not constitute endorsement or recommendation for use. The results of data analyses by computer programs described in the section on data analysis were verified using data commonly obtained from effluent toxicity tests. However, these computer programs may not be applicable to all data, and the USEPA assumes no responsibility for their use.

FOREWORD

Environmental measurements are required to determine the quality of ambient waters and the character of waste effluent. The Environmental Monitoring Systems Laboratory-Cincinnati (EMSL-Cincinnati) conducts research to:

- Develop and evaluate analytical methods to identify and measure the concentration of chemical pollutants in drinking waters, surface waters, groundwaters, wastewaters, sediments, sludges, and solid wastes.
- Investigate methods for the identification and measurement of viruses, bacteria and other microbiological organisms in aqueous samples and to determine the responses of aquatic organisms to water quality.
- Develop and operate a quality assurance program to support the achievement of data quality objectives in measurements of pollutants in drinking water, surface water, groundwater, wastewater, sediment and solid waste.
- Develop methods and models to detect and quantify responses in aquatic and terrestrial organisms exposed to environmental stressors and to correlate the exposure with effects on chemical and biological indicators.

The Federal Water Pollution Control Act Amendments of 1972 (PL 92-500), the Clean Water Act (CWA) of 1977 (PL 95-217) and the Water Quality Act of 1987 (PL 100-4) explicitly state that it is the national policy that the discharge of toxic substances in toxic amounts be prohibited. Thus, the detection of chronically toxic effluents plays an important role in identifying and controlling toxic discharges to surface waters. This manual is the second edition of the marine and estuarine chronic toxicity test manual for effluents, first published (EPA/600/4-87/028) by EMSL-Cincinnati in May 1988. It provides updated and standardized methods for estimating the chronic toxicity of effluents and receiving waters to estuarine and marine organisms for use by the U. S. Environmental Protection Agency (USEPA) regional programs, the state programs, and the National Pollutant Discharge Elimination System (NPDES) permittees.

Thomas A. Clark, Director
Environmental Monitoring Systems
Laboratory-Cincinnati

PREFACE

This manual represents the second edition of the Agency's methods manual for estimating the chronic toxicity of effluents and receiving waters to marine and estuarine organisms initially published by USEPA's Office of Research and Development, Environmental Monitoring and Support Laboratory (EMSL-Cincinnati) in May 1988. This edition reflects changes recommended by the Toxicity Assessment Subcommittee of the Biological Advisory Committee, USEPA headquarters, program offices, and regional staff, other Federal agencies, state and interstate water pollution control programs, environmental protection groups, trade associations, major industries, consulting firms, academic institutions engaged in aquatic toxicology research, and other interested parties in the private sector.

The membership of the Toxicity Assessment Subcommittee, USEPA's Biological Advisory Committee is as follows:

William Peltier, Subcommittee Chairman,
Environmental Services Division, Region 4
Peter Nolan, Environmental Services Division, Region 1
Jim Ferretti, Environmental Services Division, Region 2
Ronald Preston, Environmental Services Division, Region 3
Charles Steiner, Environmental Services Division, Region 5
Evan Hornig, Environmental Services Division, Region 6
Terry Hollister, Environmental Services Division, Region 6
Michael Tucker, Environmental Services Division, Region 7
Loys Parrish, Environmental Services Division, Region 8
Peter Husby, Environmental Services Division, Region 9
Joseph Cummins, Environmental Services Division, Region 10
Gretchen Hayslip, Water Monitoring and Analysis Section, Region 10
Bruce Binkley, National Enforcement Investigations Center, Denver
Wesley Kinney, Environmental Monitoring Systems Laboratory-Las Vegas
James Lazorchak, Environmental Monitoring Systems Laboratory-Cincinnati
Douglas Middaugh, Environmental Research Laboratory-Gulf Breeze
George Morrison, Environmental Research Laboratory-Narragansett
Teresa Norberg-King, Environmental Research Laboratory-Duluth
Donald Klemm, Environmental Monitoring Systems Laboratory-Cincinnati
Philip Lewis, Environmental Monitoring Systems Laboratory-Cincinnati
Cornelius I. Weber, Environmental Monitoring Systems Laboratory-
Cincinnati
Richard Swartz, Environmental Research Laboratory-Newport
Margarete Heber, Human Health and Ecological Criteria Division, Office
of Science & Technology (OST), Office of Water (OW)
Bruce Newton, Assessment and Watershed Protection Division, Office
of Wetlands, Oceans, and Watersheds, OW
Christopher Zarba, Health and Ecological Criteria Division, Office
of Science & Technology, OW
Daniel Rieder, Hazard Evaluation Division, Office of Pesticide
Programs
Jerry Smrcek, Health and Environmental Review Division, Office
of Toxic Substances

Gail Hansen, Office of Solid Waste
Royal Nadeau, Emergency Response Team, Edison

Teresa J. Norberg-King
Chairman, Biological Advisory Committee
Regulatory Ecotoxicology Branch, ERL-Duluth

ABSTRACT

This manual describes six short-term (one hour to nine days) estuarine and marine methods for measuring the chronic toxicity of effluents and receiving waters to five species: the sheepshead minnow, *Cyprinodon variegatus*; the inland silverside, *Menidia beryllina*; the mysid, *Mysidopsis bahia*; the sea urchin, *Arbacia punctulata*; and the red macroalga, *Champia parvula*. The methods include single and multiple concentration static renewal and static nonrenewal toxicity tests for effluents and receiving waters. Also included are guidelines on laboratory safety, quality assurance, facilities, and equipment and supplies; dilution water; effluent and receiving water sample collection, preservation, shipping, and holding; test conditions; toxicity test data analysis; report preparation; and organism culturing, holding, and handling. Examples of computer input and output for Dunnett's Procedure, Probit Analysis, Trimmed Spearman-Kärber Method, and the Linear Interpolation Method are provided in the Appendices.

CONTENTS

	Page
Foreword	iii
Preface	iv
Abstract	vi
Figures	xii
Tables	xviii
Acknowledgments	xxix

Section Number	Page
1. Introduction	1
2. Short-Term Methods for Estimating Chronic Toxicity	4
Introduction	4
Types of Tests	7
Static Tests	8
Advantages and Disadvantages of Toxicity Test Types	8
3. Health and Safety	10
General Precautions	10
Safety Equipment	10
General Laboratory and Field Operations	10
Disease Prevention	11
Safety Manuals	11
Waste Disposal	11
4. Quality Assurance	12
Introduction	12
Facilities, Equipment, and Test Chambers	12
Test Organisms	13
Laboratory Water Used for Culturing and and Test Dilution Water	13
Effluent and Receiving Water Sampling and Handling	13
Test Conditions	13
Quality of Test Organisms	14
Food Quality	14
Acceptability of Chronic Toxicity Tests	15
Analytical Methods	16
Calibration and Standardization	16
Replication and Test Sensitivity	16
Variability in Toxicity Test Results	16
Test Precision	17
Demonstrating Acceptable Laboratory Performance	18
Documenting Ongoing Laboratory Performance	18
Reference Toxicants	21
Record Keeping	21
Video Tapes of USEPA Culture and Toxicity Test Methods	21
Supplemental Reports for Training Video Tapes	22
5. Facilities, Equipment, and Supplies	23
General Requirements	23
Test Chambers	24

CONTENTS (CONTINUED)

Section Number	Page
Cleaning Test Chambers and Laboratory Apparatus	24
Apparatus and Equipment for Culturing and Toxicity Tests	25
Reagents and Consumable Materials	25
Test Organisms	25
Supplies	25
6. Test Organisms	27
Test Species	27
Sources of Test Organisms	28
Life Stage	29
Laboratory Culturing	29
Holding and Handling of Test Organisms	29
Transportation to the Test Site	30
Test Organism Disposal	31
7. Dilution Water	32
Types of Dilution Water	32
Standard, Synthetic Dilution Water	32
Use of Receiving Water as Dilution Water	34
Use of Tap Water as Dilution Water	36
Dilution Water Holding	36
8. Effluent and Receiving Water Sampling, Sample Handling, and Sample Preparation for Toxicity Tests	37
Effluent Sampling	37
Effluent Sample Types	37
Effluent Sampling Recommendations	38
Receiving Water Sampling	39
Effluent and Receiving Water Sample Handling, Preservation, and Shipping	40
Sample Receiving	41
Persistence of Effluent Toxicity During Sample Shipment and Holding	41
Preparation of Effluent and Receiving Water Samples for Toxicity Tests	41
Preliminary Toxicity Range-finding Tests	45
Multiconcentration (Definitive) Effluent Toxicity Tests	45
Receiving Water Tests	46
9. Chronic Toxicity Test Endpoints and Data Analysis	47
Endpoints	47
Relationship between Endpoints Determined by Hypothesis Testing and Point Estimation Techniques	48
Precision	50
Data Analysis	50
Choice of Analysis	52
Hypothesis Tests	54
Point Estimation Techniques	56

CONTENTS (CONTINUED)

Section Number	Page
10. Report Preparation	58
Introduction	58
Plant Operations	58
Source of Effluent, Receiving Water, and Dilution Water	58
Test Methods	59
Test Organisms	59
Quality Assurance	59
Results	59
Conclusions and Recommendations	60
11. Test Method: Sheepshead Minnow, <i>Cyprinodon variegatus</i> , Larval Survival and Growth Test Method 1004.0	61
Scope and Application	61
Summary of Method	61
Interferences	61
Safety	62
Apparatus and Equipment	62
Reagents and Consumable Materials	64
Effluent and Receiving Water Collection, Preservation, and Storage	74
Calibration and Standardization	74
Quality Control	74
Test Procedures	74
Summary of Test Conditions and Test Acceptability Criteria	84
Acceptability of Test Results	84
Data Analysis	84
Precision and Accuracy	116
12. Test Method: Sheepshead Minnow, <i>Cyprinodon variegatus</i> , Embryo- larval Survival and Teratogenicity Test Method 1005.0	124
Scope and Application	124
Summary of Method	124
Interferences	124
Safety	125
Apparatus and Equipment	125
Reagents and Consumable Materials	127
Effluent and Receiving Water Collection, Preservation, and Storage	137
Calibration and Standardization	137
Quality Control	138
Test Procedures	138
Acceptability of Test Results	144
Summary of Test Conditions and Test Acceptability Criteria	144
Data Analysis	144
Precision and Accuracy	160
13. Test Method: Inland Silverside, <i>Menidia beryllina</i> , Larval Survival and Growth Method 1006.0	163
Scope and Application	163
Summary of Method	163

CONTENTS (CONTINUED)

Section Number	Page
Interferences	163
Safety	164
Apparatus and Equipment	164
Reagents and Consumable Materials	167
Effluent and Receiving Water Collection, Preservation, and Storage	177
Calibration and Standardization	177
Quality Control	177
Test Procedures	177
Summary of Test Conditions and Test Acceptability Criteria	186
Acceptability of Test Results	186
Data Analysis	186
Precision and Accuracy	216
14. Test Method: Mysid, <i>Mysidopsis bahia</i> , Survival, Growth, and Fecundity Test Method 1007.0	222
Scope and Application	222
Summary of Method	222
Interferences	222
Safety	223
Apparatus and Equipment	223
Reagents and Consumable Materials	225
Effluent and Receiving Water Collection, Preservation, and Storage	235
Calibration and Standardization	235
Quality Control	235
Test Procedures	235
Summary of Test Conditions and Test Acceptability Criteria	243
Acceptability of Test Results	243
Data Analysis	243
Precision and Accuracy	294
15. Test Method: Sea Urchin, <i>Arbacia punctulata</i> , Fertilization Test Method 1008.0	300
Scope and Application	300
Summary of Method	300
Interferences	300
Safety	301
Apparatus and Equipment	301
Reagents and Consumable Materials	302
Effluent and Receiving Water Collection, Preservation, and Storage	311
Calibration and Standardization	311
Quality Control	311
Test Procedures	311
Summary of Test Conditions and Test Acceptability Criteria	316
Acceptability of Test Results	316
Data Analysis	319
Precision and Accuracy	333

CONTENTS (CONTINUED)

Section Number	Page
16. Test Method: Red Macroalga, <i>Champia parvula</i> , Reproduction Test	
Method 1009.0	341
Scope and Application	341
Summary of Method	341
Interferences	341
Safety	342
Apparatus and Equipment	342
Reagents and Consumable Materials	343
Effluent and Receiving Water Collection, Preservation, and Storage	350
Calibration and Standardization	351
Quality Control	351
Test Procedures	351
Summary of Test Conditions and Test Acceptability Criteria	356
Acceptability of Test Results	360
Data Analysis	360
Precision and Accuracy	373
Cited References	380
Bibliography	391
Appendices	401
A. Independence, Randomization, and Outliers	403
B. Validating Normality and Homogeneity of Variance Assumptions	409
C. Dunnett's Procedure	419
D. T test with Bonferroni's Adjustment	432
E. Steel's Many-one Rank Test	438
F. Wilcoxon Rank Sum Test	443
G. Single Concentration Toxicity Test - Comparison of Control with 100% Effluent or Receiving Water	450
H. Probit Analysis	454
I. Spearman-Karber Method	457
J. Trimmed Spearman-Karber Method	462
K. Graphical Method	467
L. Linear Interpolation Method	471
Cited References	482

FIGURES

SECTION 1-10

Number	Page
1. Control (cusum) charts	20
2. Flowchart for statistical analysis of test data	53

SECTION 11

Number	Page
1. Embryonic development of sheepshead minnow, <i>Cyprinodon variegatus</i>	72
2. Data form for the sheepshead minnow, <i>Cyprinodon variegatus</i> , larval survival and growth test. Daily record of larval survival and test conditions	80
3. Data form for the sheepshead minnow, <i>Cyprinodon variegatus</i> , larval survival and growth test. Dry weights of larvae	83
4. Data form for the sheepshead minnow, <i>Cyprinodon variegatus</i> , larval survival and growth test. Summary of test results	85
5. Flowchart for statistical analysis of the sheepshead minnow, <i>Cyprinodon variegatus</i> , larval survival data by hypothesis testing	89
6. Flowchart for statistical analysis of the sheepshead minnow, <i>Cyprinodon variegatus</i> , larval survival data by point estimation	90
7. Plot of mean survival proportion data in Table 5	93
8. Flowchart for statistical analysis of the sheepshead minnow, <i>Cyprinodon variegatus</i> , larval growth data	101
9. Plot of weight data from sheepshead minnow, <i>Cyprinodon variegatus</i> , larval survival and growth test.	103
10. Plot of raw data, observed means and smoothed means for the sheepshead minnow, <i>Cyprinodon variegatus</i> , growth data from Tables 4 and 21	112

FIGURES (CONTINUED)

SECTION 11 (Continued)

Number	Page
11. ICPIN program output for the IC25	114
12. ICPIN program output for the IC50	115

SECTION 12

Number	Page
1. Data form for sheepshead minnow, <i>Cyprinodon variegatus</i> , embryo-larval survival and teratogenicity test. Daily record of embryo-larval survival/terata and test conditions.	128
2. Embryonic development of sheepshead minnow, <i>Cyprinodon variegatus</i>	142
3. Flowchart for statistical analysis of sheepshead minnow, <i>Cyprinodon variegatus</i> , embryo-larval survival and teratogenicity test. Survival and terata data	148
4. Plot of sheepshead minnow, <i>Cyprinodon variegatus</i> , total mortality data from the embryo-larval test	150
5. Output for USEPA Probit Analysis program, Version 1.5	159

SECTION 13

Number	Page
1. Glass chamber with sump area	166
2. Inland silverside, <i>Menidia beryllina</i>	176
3. Data form for the inland silverside, <i>Menidia beryllina</i> , larval survival and growth test. Daily record of larval survival and test conditions	182
4. Data form for the inland silverside, <i>Menidia beryllina</i> , larval survival and growth test. Dry weights of larvae	185
5. Data form for the inland silverside, <i>Menidia beryllina</i> , larval survival and growth test. Summary of test results	187

FIGURES (CONTINUED)

SECTION 13 (Continued)

Number	Page
6. Flowchart for statistical analysis of the inland silverside, <i>Menidia beryllina</i> , survival data by hypothesis testing	191
7. Flowchart for statistical analysis of the inland silverside, <i>Menidia beryllina</i> , survival data by point estimation	192
8. Plot of mean survival proportion of the inland silverside, <i>Menidia beryllina</i> , larvae	193
9. Output for USEPA Probit Analysis program, Version 1.5	203
10. Flowchart for statistical analysis of the inland silverside, <i>Menidia beryllina</i> , growth data	204
11. Plot of mean weights of inland silverside, <i>Menidia beryllina</i> , larval survival and growth test	206
12. Plot of the raw data, observed means, and smoothed means from Tables 13 and 19	215
13. ICPIN program output for the IC25	217
14. ICPIN program output for the IC50	218

SECTION 14

Number	Page
1. Apparatus (brood chamber) for collection of juvenile mysids, <i>Mysidopsis bahia</i>	234
2. Data form for the mysid, <i>Mysidopsis bahia</i> , water quality measurements	240
3. Mature female mysid, <i>Mysidopsis bahia</i> , with eggs in oviducts	241
4. Mature female mysid, <i>Mysidopsis bahia</i> , with eggs in oviducts and developing embryos in the brood sac	242
5. Mature male mysid, <i>Mysidopsis bahia</i>	243
6. Immature mysid, <i>Mysidopsis bahia</i> , (A) lateral view, (B) dorsal view	244

FIGURES (CONTINUED)

SECTION 14 (Continued)

Number	Page
7. Data form for the mysid, <i>Mysidopsis bahia</i> , survival and fecundity data	245
8. Data form for the mysid, <i>Mysidopsis bahia</i> , dry weight measurements	247
9. Flowchart for statistical analysis of mysid, <i>Mysidopsis bahia</i> , survival data by hypothesis testing	253
10. Flowchart for statistical analysis of mysid, <i>Mysidopsis bahia</i> , survival data by point estimation	254
11. Plot of survival proportions of mysids, <i>Mysidopsis bahia</i> , at each treatment level	255
12. Output for USEPA Probit Analysis program, Version 1.5	262
13. Flowchart for statistical analysis of mysid, <i>Mysidopsis bahia</i> , growth data	264
14. Plot of mean growth data for mysid, <i>Mysidopsis bahia</i> , test	265
15. Plot of raw data, observed means, and smoothed means for the mysid, <i>Mysidopsis bahia</i> , growth data from Tables 13 and 20	274
16. ICPIN program output for the IC25	276
17. ICPIN program output for the IC50	277
18. Flowchart for statistical analysis of mysid, <i>Mysidopsis bahia</i> , fecundity data	278
19. Proportion of female mysids, <i>Mysidopsis bahia</i> , with eggs	280
20. Plot of the mean proportion of females mysids, <i>Mysidopsis bahia</i> , with eggs	290
21. ICPIN program output for the IC25	292
22. ICPIN program output for the IC50	293

FIGURES (CONTINUED)

SECTION 15

Number	Page
1. Data form for (1) fertilization test using sea urchin, <i>Arbacia punctulata</i>	304
2. Data form (2) for fertilization test using sea urchin, <i>Arbacia punctulata</i>	305
3. Data form (3) for fertilization test using sea urchin, <i>Arbacia punctulata</i>	306
4. Flowchart for statistical analysis of sea urchin, <i>Arbacia punctulata</i> , by point estimation	321
5. Plot of mean percent of fertilized sea urchin, <i>Arbacia punctulata</i> , eggs	322
6. ICPIN program output for the IC25	332
7. ICPIN program output for the IC50	334

SECTION 16

Number	Page
1. Life history of the red macroalga, <i>Champia parvula</i>	347
2. Apex of branch of female plant, showing sterile hairs and reproductive hairs (trichogynes)	349
3. A portion of the male thallus showing spermatial sori	349
4. A magnified portion of a spermatial sorus	350
5. Apex of a branch on a mature female plant that was exposed to spermatia from a male plant	350
6. Data form for the red macroalga, <i>Champia parvula</i> , sexual reproduction test. Receiving water summary sheet	352
7. A mature cystocarp	355
8. Comparison of a very young branch and an immature cystocarp	356

FIGURES (CONTINUED)

SECTION 16 (Continued)

Number	Page
9. An aborted cystocarp	356
10. Data form for the red macroalga, <i>Champia parvula</i> , sexual reproduction test. Cystocarp data sheet	357
11. Flowchart for statistical analysis of the red macroalga, <i>Champia parvula</i> , data	362
12. Plot of the number of cystocarps per plant	364
13. ICPIN program output for the IC25	374
14. ICPIN program output for the IC50	375

TABLES

SECTION 1-10

Number	Page
1. National Interlaboratory study of chronic toxicity test precision, 1991: Summary of responses using two reference toxicants	18
2. Commercial suppliers of brine shrimp (<i>Artemia</i>) cysts	26
3. Preparation of GP2 artificial seawater using reagent grade chemicals	34
4. Oxygen solubility (mg/L) in water at equilibrium with air at 760 mm Hg	43
5. Percent unionized NH_3 in aqueous ammonia solutions: temperature 15-26°C and pH 6.0-8.9	44

SECTION 11

Number	Page
1. Reagent grade chemicals used in the preparation of GP2 artificial seawater for the sheepshead minnow, <i>Cyprinodon variegatus</i> , toxicity test	67
2. Preparation of test solutions at a salinity of 20‰, using 20‰ salinity dilution water prepared from natural seawater, hypersaline brine, or artificial sea salts	76
3. Summary of test conditions and test acceptability criteria for sheepshead minnow, <i>Cyprinodon variegatus</i> , larval survival and growth test with effluents and receiving waters	86
4. Summary of survival and growth data for sheepshead minnow, <i>Cyprinodon variegatus</i> , larvae exposed to an effluent for seven days	88
5. Sheepshead minnow, <i>Cyprinodon variegatus</i> , survival data	92
6. Centered observations for Shapiro-Wilk's example	92
7. Ordered centered observations for the Shapiro-Wilk's example	94
8. Coefficients and differences for Shapiro-Wilk's example	95

TABLES (CONTINUED)

SECTION 11 (Continued)

Number	Page
9. Assigning ranks to the control and 6.25% effluent concentration for Steel's Many-one Rank Test	96
10. Table of ranks	96
11. Rank sums	96
12. Data for example of Spearman-Kärber Analysis	98
13. Sheepshead minnow, <i>Cyprinodon variegatus</i> , growth data	102
14. Centered observations for Shapiro-Wilk's example	102
15. Ordered centered observations for Shapiro-Wilk's example	104
16. Coefficients and differences for Shapiro-Wilk's example	105
17. ANOVA table	107
18. ANOVA table for Dunnett's Procedure example	109
19. Calculated t values	110
20. Sheepshead minnow, <i>Cyprinodon variegatus</i> , mean growth response after smoothing	111
21. Single-laboratory precision of the sheepshead minnow, <i>Cyprinodon variegatus</i> , larval survival and growth test performed in FORTY FATHOMS® artificial seawater, using larvae from fish maintained and spawned in FORTY FATHOMS® artificial seawater, using copper (Cu) sulfate as a reference toxicant	117
22. Single-laboratory precision of the sheepshead minnow, <i>Cyprinodon variegatus</i> , larval survival and growth test performed in FORTY FATHOMS® artificial seawater, using larvae from fish maintained and spawned in FORTY FATHOMS® artificial seawater, using sodium dodecyl sulfate (SDS) as a reference toxicant	118

TABLES (CONTINUED)

SECTION 11 (Continued)

Number	Page
23. Single-laboratory precision of the sheepshead minnow, <i>Cyprinodon variegatus</i> , larval survival and growth test performed in natural seawater, using larvae from fish maintained and spawned in natural seawater, using copper (Cu) sulfate as a reference toxicant	119
24. Single-laboratory precision of the sheepshead minnow, <i>Cyprinodon variegatus</i> , larval survival and growth test performed in natural seawater, using larvae from fish maintained and spawned in natural seawater, using sodium dodecyl sulfate (SDS) as a reference toxicant	120
25. Single-laboratory precision of the sheepshead minnow, <i>Cyprinodon variegatus</i> , larval survival and growth test performed in FORTY FATHOMS® artificial seawater, using larvae from fish maintained and spawned in FORTY FATHOMS® artificial seawater, and hexavalent chromium as a reference toxicant	121
26. Comparison of larval survival (LC50) and growth (IC50) values for the sheepshead minnow, <i>Cyprinodon variegatus</i> , exposed to sodium dodecyl sulfate (SDS) and copper (Cu) sulfate in GP2 artificial seawater medium or natural seawater	122
27. Data from interlaboratory study of the sheepshead minnow, <i>Cyprinodon variegatus</i> , larval survival and growth test, using an industrial effluent as a reference toxicant	123

SECTION 12

Number	Page
1. Preparation of test solutions at a salinity of 20‰, using 20‰ natural or artificial seawater, hypersaline brine, or artificial sea salts	132
2. Summary of test conditions and test acceptability criteria for sheepshead minnow, <i>Cyprinodon variegatus</i> , embryo-larval survival and teratogenicity test with effluents and receiving waters	145
3. Sheepshead minnow, <i>Cyprinodon variegatus</i> , embryo-larval total mortality data	149

TABLES (CONTINUED)

SECTION 12 (Continued)

Number	Page
4. Centered observation for Shapiro-Wilk's example	149
5. Ordered centered observations for Shapiro-Wilk's example	151
6. Coefficients and differences for Shapiro-Wilk's example	152
7. ANOVA table	154
8. ANOVA table for Dunnett's Procedure example	156
9. Calculated t values	157
10. Data for Probit Analysis	158
11. Single-laboratory precision of the sheepshead minnow, <i>Cyprinodon variegatus</i> , embryo-larval survival and teratogenicity test performed in HW MARINEMIX® artificial seawater, using embryos from fish maintained and spawned in HW MARINEMIX® artificial seawater using copper (Cu) sulfate as a reference toxicant	161
12. Single-laboratory precision of the sheepshead minnow, <i>Cyprinodon variegatus</i> , embryo-larval survival and teratogenicity test performed in HW MARINEMIX® artificial seawater, using embryos from fish maintained and spawned in HW MARINEMIX® artificial seawater using sodium dodecyl sulfate (SDS) as a reference toxicant	162

SECTION 13

Number	Page
1. Preparation of 3 L saline water from deionized water and a hypersaline brine of 100‰ needed for test solutions at 20‰ salinity	170
2. Reagent grade chemicals used in the preparation of GP2 artificial seawater for the inland silverside, <i>Menidia beryllina</i> , toxicity test	171
3. Summary of test conditions and test acceptability criteria for inland silverside, <i>Menidia beryllina</i> , larval survival and growth test with effluents and receiving waters	188

TABLES (CONTINUED)

SECTION 13 (Continued)

Number	Page
4. Inland silverside, <i>Menidia beryllina</i> , larval survival data . . .	194
5. Centered observations for Shapiro-Wilk's example	194
6. Ordered centered observations for Shapiro-Wilk's example . . .	195
7. Coefficients and differences for Shapiro-Wilk's example . . .	196
8. ANOVA table	198
9. ANOVA table for Dunnett's Procedure example	199
10. Calculated t values	200
11. Data for Probit Analysis	202
12. Inland silverside, <i>Menidia beryllina</i> , growth data	205
13. Centered observations for Shapiro-Wilk's example	205
14. Ordered centered observations for Shapiro-Wilk's example . . .	207
15. Coefficients and differences for Shapiro-Wilk's example . . .	208
16. ANOVA table	210
17. ANOVA table for Dunnett's Procedure example	211
18. Calculated t values	212
19. Inland silverside mean growth response after smoothing	214
20. Single-laboratory precision of the inland silverside, <i>Menidia beryllina</i> , survival and growth test performed in natural seawater, using larvae from fish maintained and spawned in natural seawater, and copper (Cu) as a reference toxicant	219
21. Single-laboratory precision of the inland silverside, <i>Menidia beryllina</i> , survival and growth test performed in natural seawater, using larvae from fish maintained and spawned in natural seawater, and sodium dodecyl sulfate (SDS) as a reference toxicant	220

TABLES (CONTINUED)

SECTION 13 (Continued)

Number	Page
22. Comparison of the single-laboratory precision of the inland silverside, <i>Menidia beryllina</i> , larval survival (LC50) and growth (IC50) values exposed to sodium dodecyl sulfate (SDS) or copper (Cu) sulfate, in GP2 artificial seawater medium or natural seawater	221

SECTION 14

Number	Page
1. Reagent grade chemicals used in the preparation of GP2 artificial seawater for the mysid, <i>Mysidopsis bahia</i> , toxicity test	228
2. Quantities of effluent, deionized water, and hypersaline brine (100‰) needed to prepare 1800 mL volumes of test solution with a salinity of 20‰	229
3. Summary of test conditions and test acceptability criteria for the mysid, <i>Mysidopsis bahia</i> , seven day survival, growth, and fecundity test with effluents and receiving waters	249
4. Data for <i>Mysidopsis bahia</i> 7-day survival, growth, and fecundity test	251
5. Mysid, <i>Mysidopsis bahia</i> , survival data	256
6. Centered observations for Shapiro-Wilk's example	257
7. Ordered centered observations for Shapiro-Wilk's example	258
8. Coefficients and differences for Shapiro-Wilk's example	259
9. Assigning ranks to the control and 50 ppb concentration level for Steel's Many-one Rank Test	260
10. Table of ranks	261
11. Rank sums	261
12. Data for Probit Analysis	263

TABLES (CONTINUED)

SECTION 14 (Continued)

Number	Page
13. Mysid, <i>Mysidopsis bahia</i> , growth data	263
14. Centered observations for Shapiro-Wilk's example	266
15. Ordered centered observations for Shapiro-Wilk's example	267
16. Coefficients and differences for Shapiro-Wilk's example	268
17. ANOVA table	270
18. ANOVA table for Dunnett's Procedure example	271
19. Calculated t values	272
20. Mysid, <i>Mysidopsis bahia</i> , mean growth response after smoothing	273
21. Mysid, <i>Mysidopsis bahia</i> , fecundity data: Percent females with eggs	281
22. Centered observations for Shapiro-Wilk's example	282
23. Ordered centered observations for Shapiro-Wilk's example	283
24. Coefficients and differences for Shapiro-Wilk's example	283
25. ANOVA table	285
26. ANOVA table for the t test with Bonferroni's Adjustment example	287
27. Calculated t values	288
28. Mysid, <i>Mysidopsis bahia</i> , mean proportion of females with eggs	289
29. Single-laboratory precision of the mysid, <i>Mysidopsis bahia</i> , survival, growth, and fecundity test performed in natural seawater, using juveniles from mysids cultured and spawned in natural seawater and copper (Cu) sulfate as a reference toxicant	295

TABLES (CONTINUED)

SECTION 14 (Continued)

Number	Page
30. Single-laboratory precision of the mysid, <i>Mysidopsis bahia</i> , survival, growth, and fecundity test performed in natural seawater, using juveniles from mysids cultured and spawned in natural seawater and sodium dodecyl sulfate (SDS) as a reference toxicant	296
31. Comparison of survival (LC50), growth and fecundity (IC50) results from 7-day tests with the mysid, <i>Mysidopsis bahia</i> , using natural seawater (NSW) and artificial seawater (GP2) as dilution water and sodium dodecyl sulfate (SDS) as a reference toxicant	297
32. Comparison of survival (LC50), growth and fecundity (IC50) results from 7-day tests with the mysid, <i>Mysidopsis bahia</i> , using natural seawater (NSW) and artificial seawater (GP2) as dilution water and copper (Cu) sulfate as a reference toxicant	298
33. Control results from 7-day survival, growth, and fecundity tests with the mysid, <i>Mysidopsis bahia</i> , using natural seawater and artificial seawater (GP2) as a dilution water	299

SECTION 15

Number	Page
1. Preparation of test solutions at a salinity of 30‰ using natural seawater, hypersaline brine, or artificial sea salts	309
2. Reagent grade chemicals used in the preparation of GP2 artificial seawater for the sea urchin, <i>Arbacia punctulata</i> toxicity test	310
3. Summary of test conditions and test acceptability criteria for sea urchin, <i>Arbacia punctulata</i> , fertilization test with effluent and receiving waters	317
4. Data from sea urchin, <i>Arbacia punctulata</i> , fertilization test	319
5. Sea urchin, <i>Arbacia punctulata</i> , fertilization data	323
6. Centered observations for Shapiro-Wilk's example	323
7. Ordered centered observations for Shapiro-Wilk's example	324

TABLES (CONTINUED)

SECTION 15 (Continued)

Number	Page
8. Coefficients and differences for Shapiro-Wilk's example	325
9. ANOVA table	326
10. ANOVA table for Dunnett's Procedure example	328
11. Calculated t values	329
12. Sea urchin, <i>Arbacia punctulata</i> , mean proportion of fertilized eggs	331
13. Single-laboratory precision of the sea urchin, <i>Arbacia punctulata</i> , fertilization test performed in FORTY FATHOMS® artificial seawater, using gametes from adults maintained in FORTY FATHOMS® artificial seawater, or obtained directly from natural sources, and copper (Cu) sulfate as reference toxicant	335
14. Single-laboratory precision of the sea urchin, <i>Arbacia punctulata</i> , fertilization test performed in FORTY FATHOMS® artificial seawater, using gametes from adults maintained in FORTY FATHOMS® artificial seawater, or obtained directly from natural sources, and sodium dodecyl sulfate (SDS) as a reference toxicant	336
15. Single-laboratory precision of the sea urchin, <i>Arbacia punctulata</i> , fertilization test performed in natural seawater, using gametes from adults maintained in natural seawater and copper (Cu) sulfate as a reference toxicant	337
16. Single-laboratory precision of the sea urchin, <i>Arbacia punctulata</i> , fertilization test performed in natural seawater, using gametes from adults maintained in natural seawater and sodium dodecyl sulfate (SDS) as a reference toxicant	338
17. Single-laboratory precision of the sea urchin, <i>Arbacia punctulata</i> , fertilization test performed in GP2, using gametes from adults maintained in GP2 artificial seawater and copper (Cu) sulfate and sodium dodecyl sulfate (SDS) as reference toxicants	339

TABLES (CONTINUED)

SECTION 15 (Continued)

Number	Page
18. Single-laboratory precision of the sea urchin, <i>Arbacia punctulata</i> , fertilization test performed in natural seawater, using gametes from adults maintained in natural seawater and copper (Cu) sulfate and sodium dodecyl sulfate (SDS) as reference toxicants	340

SECTION 16

Number	Page
1. Nutrients to be added to natural seawater and to artificial seawater (GP2) described in Table 2	345
2. Reagent grade chemicals used in the preparation of GP2 artificial seawater for use in conjunction with natural seawater for the red macroalga, <i>Champia parvula</i> , culturing and toxicity testing	346
3. Summary of test conditions and test acceptability criteria for red macroalga, <i>Champia parvula</i> , sexual reproduction test with effluents and receiving waters	358
4. Data from the red macroalga, <i>Champia parvula</i> , effluent toxicity test. Cystocarp counts for individual plants and mean count per test chamber for each effluent concentration	361
5. The red macroalga, <i>Champia parvula</i> , sexual reproduction data	363
6. Centered observations for Shapiro-Wilk's example	365
7. Ordered centered observations for Shapiro-Wilk's example	366
8. Coefficients and differences for Shapiro-Wilk's example	366
9. ANOVA table	368
10. ANOVA table for Dunnett's Procedure example	370
11. Calculated t values	371
12. Red macroalga, <i>Champia parvula</i> , mean number of cystocarps	372

TABLES (CONTINUED)

SECTION 16 (Continued)

Number	Page
13. Single-laboratory precision of the red macroalga, <i>Champia parvula</i> , reproduction test performed in a 50/50 mixture of natural seawater and GP2 artificial seawater, using gametes from adults cultured in natural seawater. The reference toxicant used was copper (Cu) sulfate	376
14. Single-laboratory precision of the red macroalga, <i>Champia parvula</i> , reproduction test performed in a 50/50 mixture of natural seawater and GP2 artificial seawater, using gametes from adults cultured in natural seawater. The reference toxicant used was sodium dodecyl sulfate (SDS)	377
15. Single-laboratory precision of the red macroalga, <i>Champia parvula</i> , reproduction test in natural seawater (30‰ salinity). The reference toxicant used was copper (Cu) sulfate	378
16. Single-laboratory precision of the red macroalga, <i>Champia parvula</i> , reproduction test in natural seawater (30‰ salinity). The reference toxicant used was sodium dodecyl sulfate (SDS)	379

ACKNOWLEDGMENTS

The principal authors of this document are Donald Klemm, Cornelius Weber, Philip Lewis, James Lazorchak, Florence Fulk, and Timothy Neiheisel, Environmental Monitoring Systems Laboratory-Cincinnati, Ohio; George Morrison, Environmental Research Laboratory, Narragansett, Rhode Island; Dennis M. McMullen, Technology Applications Incorporated, Cincinnati, Ohio and Cathy Poore, Computer Sciences Corporation, Cincinnati, Ohio. Contributors to specific sections of this manual are listed below.

1. Sections 1-10; General Guidelines

Margarete Heber, OST, Office of Water
Donald Klemm, EMSL-Cincinnati
James Lazorchak, EMSL-Cincinnati
Philip Lewis, EMSL-Cincinnati
George Morrison, ERL-Narragansett
Teresa Norberg-King, ERL - Duluth
William Peltier, ESD, Region 4
Cornelius Weber, EMSL - Cincinnati

2. Sections 11-16; Toxicity Test Methods

Margarete Heber, OST, Office of Water
Donald Klemm, EMSL-Cincinnati
George Morrison, ERL-Narragansett
William Peltier, ESD, Region 4
Quentin Pickering, EMSL-Cincinnati

3. Data Analysis (Section 9, 11-16, and Appendices)

Florence Fulk, EMSL-Cincinnati
Laura Gast, Technology Applications, Inc. (TAI)
Cathy Poore, Computer Sciences Corporation (CSC)

Review comments from the following persons are gratefully acknowledged:

Pam Comeleo, Science Application International Corporation, Environmental Research Laboratory, U.S. Environmental Protection Agency, Narragansett, RI
Randy Comeleo, Science Application International Corporation, Environmental Research Laboratory, U.S. Environmental Protection Agency, Narragansett, RI
Philip Crocker, Water Quality Management Branch, U.S. Environmental Protection Agency, Region 6, Dallas, TX
Dan Fisher, John Hopkins University, Queenstown, MD
Terry Hollister, Environmental Services Division, Houston Branch, U.S. Environmental Protection Agency, Region 6, Houston, TX
Glen Modica, Science Application International Corporation, Environmental Research Laboratory, U.S. Environmental Protection Agency, Narragansett, RI
Michael Morton, Permits Branch, U.S. Environmental Protection Agency, Region 6, Dallas, TX
Peter Nolan, Environmental Services Division, U.S. Environmental Protection

ACKNOWLEDGMENTS (CONTINUED)

Agency, Region 1, Lexington, MA
Mark Tagliabue, Science Application International Corporation, Environmental Research Laboratory, U.S. Environmental Protection Agency, Narragansett, RI
Glenn Thursby, Environmental Research Laboratory, U.S. Environmental Protection Agency, Narragansett, Rhode Island
Jerry Smrcek, Office of Pesticides and Toxic Substances, Environmental Effects Branch, Health and Environmental Review Division, U.S. Environmental Protection Agency, Washington, DC
Amy Wagner, Laboratory Support Section, U.S. Environmental Protection Agency, San Francisco, CA
Audrey Weber, Virginia Water Control Board, Glen Allen, VA

Many useful public comments on the first edition of the marine and estuarine toxicity test methods "Short-term Methods for Estimating the Chronic Toxicity of Effluents and Receiving Waters to Freshwater Organisms, EPA/600/4-87/028 (USEPA, 1988a) were received in response to the proposed rule, published in the Federal Register, December 4, 1989 [FR 54(231):50216-50224], regarding the Agency's intent to include short-term chronic toxicity tests in Table IA, 40 CFR Part 136. These comments were carefully considered in preparation of the second edition of the manual, and are included in the *Public Docket for the rulemaking*, located at room 2904, USEPA Headquarters, Washington, D.C.

Materials in this manual were taken in part from the following sources: Methods for Acute Toxicity Tests with Fish, Macroinvertebrates, and Amphibians, Environmental Research Laboratory, U.S. Environmental Protection Agency, Duluth, Minnesota, EPA-660/3-75/009 (USEPA, 1975); Handbook for Analytical Quality Control in Water and Wastewater Laboratories, Environmental Monitoring and Support Laboratory - Cincinnati, U.S. Environmental Protection Agency, Cincinnati, Ohio, EPA-600/4-79/019 (USEPA, 1979a); Methods for chemical analysis of water and wastes, Environmental Monitoring and Support Laboratory-Cincinnati, U. S. Environmental Protection Agency, Cincinnati, OH, EPA-600/4-79-020 (USEPA, 1979b); Interim NPDES Compliance Biomonitoring Inspection Manual, Enforcement Division, Office of Water Enforcement, U.S. Environmental Protection Agency, Washington, D.C. (USEPA, 1979c); Methods for Measuring the Acute Toxicity of Effluents to Freshwater and Marine Organisms, Environmental Monitoring and Support Laboratory - Cincinnati, U.S. Environmental Protection Agency, Cincinnati, Ohio, EPA-600/4-85/013 (USEPA, 1985a); Short-term Methods for Estimating the Chronic Toxicity of Effluents and Receiving Waters to Freshwater Organisms, Environmental Monitoring and Support Laboratory - Cincinnati, U.S. Environmental Protection Agency, Cincinnati, Ohio, EPA-600/4-85/014 (USEPA, 1985b); Users Guide to the Conduct and Interpretation of Complex Effluent Toxicity Tests at Estuarine/Marine Sites, Environmental Research Laboratory-Narragansett (ERL-N), U.S. Environmental Protection Agency, Narragansett, Rhode Island (USEPA, 1987a); NPDES Compliance Inspection Manual, Office of Water Enforcement and Permits (EN-338), U.S. Environmental Protection Agency, Washington, D.C. (USEPA, 1988b); Short-term Methods for Estimating the Chronic Toxicity of Effluents and Receiving Waters to Marine and Estuarine Organisms, Environmental Monitoring and Support Laboratory-Cincinnati, U.S. Environmental Protection

ACKNOWLEDGMENTS (CONTINUED)

Agency, Cincinnati, Ohio, EPA-600/4-87/028 (USEPA, 1988a); Short-term Methods for Estimating the Chronic Toxicity of Effluents and Receiving Waters to Freshwater Organisms, Environmental Monitoring Systems Laboratory-Cincinnati, U.S. Environmental Protection Agency, Cincinnati, Ohio, EPA/600/4-89/001 (USEPA, 1989a); Methods for Measuring the Acute Toxicity of Effluents to Freshwater and Marine Organisms, Environmental Monitoring Systems Laboratory-Cincinnati, U.S. Environmental Protection Agency, Cincinnati, Ohio, EPA/600/4-90/027F (USEPA, 1993a); Short-term Methods for Estimating the Chronic Toxicity of Effluents and Receiving Waters to Freshwater Organisms (Third Edition), Environmental Monitoring Systems Laboratory-Cincinnati, U.S. Environmental Protection Agency, Cincinnati, Ohio, EPA/600/4-91/002 (USEPA, 1993b); and the Technical Support Document for Water Quality-based Toxic Control, Office of Water Enforcement and Permits and Office of Water Regulations and Standards, U.S. Environmental Protection Agency, Washington, D.C., EPA/505/2-90-001 (USEPA, 1991a).

Five of the six methods in the manual were adapted from methods developed at the Environmental Research Laboratory-Narragansett. Individuals responsible for specific methods are as follows: Melissa Hughes, Margarete Heber, and Walter Berry, Science Applications International Corporation (SAIC), and Steven Schimmel, USEPA, developed the sheepshead minnow larval survival and growth test; Margarete Heber and Melissa Hughes, SAIC, Steven Schimmel, USEPA, and David Bengtson, University of Rhode Island, developed the inland silverside, *Menidia beryllina*, larval survival and growth test; Suzanne Lussier, USEPA, Anne Kuhn and John Sewall, SAIC, developed the mysid, *Mysidopsis bahia*, survival, growth, and fecundity test; Diane Nacci and Raymond Walsh, SAIC, and Eugene Jackim, USEPA, developed the sea urchin, *Arbacia punctulata*, fertilization test; and Glen Thursby, University of Rhode Island, and Richard Steele, USEPA, developed the red macroalga, *Champia parvula*, reproduction test.

Terry Hollister, U.S. Environmental Protection Agency, Region 6, Houston, Texas, adapted the sheepshead minnow, *Cyprinodon variegatus*, embryo-larval survival and teratogenicity test from the fathead minnow, *Pimephales promelas*, embryo-larval test in EPA/660/4-85/014 (USEPA, 1985b).

Debbie Hall, Bioassessment and Ecotoxicology Branch, and Mary Sullivan, Quality Assurance Research Division, provided valuable secretarial assistance, and Betty Thomas, Technical Information Manager, EMSL-Cincinnati, provided an editorial review.

SECTION 1

INTRODUCTION

1.1 This manual describes chronic toxicity tests for use in the National Pollutant Discharge Elimination System (NPDES) Permits Program to identify effluents and receiving waters containing toxic materials in chronically toxic concentrations. The methods included in this manual are referenced in Table IA, 40 CFR Part 136 regulations and, therefore, constitute approved methods for chronic toxicity tests. They are also suitable for determining the toxicity of specific compounds contained in discharges. The tests may be conducted in a central laboratory or on-site, by the regulatory agency or the permittee.

1.2 The data are used for NPDES permits development and to determine compliance with permit toxicity limits. Data can also be used to predict potential acute and chronic toxicity in the receiving water, based on the LC50, NOEC, IC25, or IC50 (see Section 9, Chronic Toxicity Test Endpoints and Data Analysis) and appropriate dilution, application, and persistence factors. The tests are performed as a part of self-monitoring permit requirements, compliance biomonitoring inspections, toxics sampling inspections, and special investigations. Data from chronic toxicity tests performed as part of permit requirements are evaluated during compliance evaluation inspections and performance audit inspections.

1.3 Modifications of these tests are also used in toxicity reduction evaluations and toxicity identification evaluations to identify the toxic components of an effluent, to aid in the development and implementation of toxicity reduction plans, and to compare and control the effectiveness of various treatment technologies for a given type of industry, irrespective of the receiving water (USEPA, 1988c; USEPA, 1989b; USEPA, 1989c; USEPA, 1989d; USEPA, 1989e; USEPA, 1991a; USEPA, 1991b; and USEPA, 1992).

1.4 This methods manual serves as a companion to the acute toxicity test methods for freshwater and marine organisms (USEPA, 1993a), the short-term chronic toxicity test methods for freshwater organisms (USEPA, 1993b), and the manual for evaluation of laboratories performing aquatic toxicity tests (USEPA, 1991c).

1.5 Guidance for the implementation of toxicity tests in the NPDES program is provided in the Technical Support Document for Water Quality-Based Toxics Control (USEPA, 1991a).

1.6 These marine and estuarine short-term toxicity tests are similar to those developed for the freshwater organisms to evaluate the toxicity of effluents discharged to estuarine and coastal marine waters under the NPDES permit program. Methods are presented in this manual for five species from four phylogenetic groups. Five of the six methods were developed and extensively field tested by Environmental Research Laboratory-Narragansett (ERL-N). The methods vary in duration from one hour and 20 minutes to nine days.

1.7 The five species for which toxicity test methods are provided are: the sheepshead minnow, *Cyprinodon variegatus*; the inland silverside, *Menidia beryllina*; the mysid, *Mysidopsis bahia*; the sea urchin, *Arbacia punctulata*; and the red macroalga, *Champia parvula*.

1.7.1 The tests included in this document are based on the following methods:

1. "Guidance manual for conducting complex effluent and receiving water larval fish growth/survival studies with the sheepshead minnow, *Cyprinodon variegatus*," by Melissa M. Hughes, Margarete A. Heber, Steven C. Schimmel and Walter J. Berry, 1987, Contribution No. X104, Environmental Research Laboratory, U.S. Environmental Protection Agency, Narragansett, RI (USEPA, 1987b).
2. "Guidance manual for rapid chronic toxicity test on effluents and receiving waters with larval inland silversides, *Menidia beryllina*," by Margarete A. Heber, Melissa M. Hughes, Steven C. Schimmel, and David Bengtson, 1987, Contribution No. 792, Environmental Research Laboratory, U.S. Environmental Protection Agency, Narragansett, RI (USEPA, 1987c).
3. "Guidance manual for conducting seven-day, mysid survival/growth/reproduction study using the estuarine mysid, *Mysidopsis bahia*," by Suzanne M. Lussier, Anne Kuhn, and John Sewall, 1987, Contribution No. X106, Environmental Research Laboratory, U.S. Environmental Protection Agency, Narragansett, RI (USEPA, 1987d).
4. "Guidance manual for conducting sperm cell tests with the sea urchin, *Arbacia punctulata*, for use in testing complex effluents," by Diane E. Nacci, Raymond Walsh, and Eugene Jackim, 1987, Contribution No. X105, Environmental Research Laboratory, U.S. Environmental Protection Agency, Narragansett, RI (USEPA, 1987e).
5. "Guidance manual for conducting sexual reproduction tests with the marine macroalga, *Champia parvula*, for use in testing complex effluents," by Glenn B. Thursby and Richard L. Steele, 1987, Contribution No. X103, Environmental Research Laboratory, U.S. Environmental Protection Agency, Narragansett, RI (USEPA, 1987f).
6. A nine-day, sheepshead minnow, *Cyprinodon variegatus*, static-renewal, embryo-larval survival and teratogenicity test, developed by Terry Hollister, USEPA, Region 6, Houston, TX.

1.7.2 Four of the methods incorporate the chronic endpoints of growth or reproduction (or both) in addition to lethality. The sheepshead minnow 9-day embryo-larval survival and teratogenicity test incorporates teratogenic effects in addition to lethality. The sea urchin sperm cell test uses fertilization as an endpoint and has the advantage of an extremely short exposure period (1 h and 20 min).

1.8 The validity of the marine/estuarine methods in predicting adverse ecological impacts of toxic discharges was demonstrated in field studies (USEPA, 1986d).

1.9 The use of any test species or test conditions other than those described in the methods summary tables in this manual shall be subject to application and approval of alternate test procedures under 40 CFR 136.4 and 40 CFR 136.5.

1.10 These methods are restricted to use by or under the supervision of analysts experienced in the use or conduct of aquatic toxicity testing and the interpretation of data from aquatic toxicity testing. Each analyst must demonstrate the ability to generate acceptable test results with these methods using the procedures described in this methods manual.

1.11 The manual was prepared in the established EMSL-Cincinnati format (USEPA, 1983).

SECTION 2

SHORT-TERM METHODS FOR ESTIMATING CHRONIC TOXICITY

2.1 INTRODUCTION

2.1.1 The objective of aquatic toxicity tests with effluents or pure compounds is to estimate the "safe" or "no-effect" concentration of these substances, which is defined as the concentration which will permit normal propagation of fish and other aquatic life in the receiving waters. The endpoints that have been considered in tests to determine the adverse effects of toxicants include death and survival, decreased reproduction and growth, locomotor activity, gill ventilation rate, heart rate, blood chemistry, histopathology, enzyme activity, olfactory function, and terata. Since it is not feasible to detect and/or measure all of these (and other possible) effects of toxic substances on a routine basis, observations in toxicity tests generally have been limited to only a few effects, such as mortality, growth, and reproduction.

2.1.2 Acute lethality is an obvious and easily observed effect which accounts for its wide use in the early period of evaluation of the toxicity of pure compounds and complex effluents. The results of these tests were usually expressed as the concentration lethal to 50% of the test organisms (LC50) over relatively short exposure periods (one-to-four days).

2.1.3 As exposure periods of acute tests were lengthened, the LC50 and lethal threshold concentration were observed to decline for many compounds. By lengthening the tests to include one or more complete life cycles and observing the more subtle effects of the toxicants, such as a reduction in growth and reproduction, more accurate, direct, estimates of the threshold or safe concentration of the toxicant could be obtained. However, laboratory life cycle tests may not accurately estimate the "safe" concentration of toxicants because they are conducted with a limited number of species under highly controlled, steady state conditions, and the results do not include the effects of the stresses to which the organisms would ordinarily be exposed in the natural environment.

2.1.4 An early published account of a full life cycle, fish toxicity test was that of Mount and Stephan (1967). In this study, fathead minnows, *Pimephales promelas*, were exposed to a graded series of pesticide concentrations throughout their life cycle, and the effects of the toxicant on survival, growth, and reproduction were measured and evaluated. This work was soon followed by full life cycle tests using other toxicants and fish species.

2.1.5 McKim (1977) evaluated the data from 56 full life cycle tests, 32 of which used the fathead minnow, *Pimephales promelas*, and concluded that the embryo-larval and early juvenile life stages were the most sensitive stages. He proposed the use of partial life cycle toxicity tests with the early life stages (ELS) of fish to establish water quality criteria.

2.1.6 Macek and Sleight (1977) found that exposure of critical life stages of fish to toxicants provides estimates of chronically safe concentrations remarkably similar to those derived from full life cycle toxicity tests. They reported that "for a great majority of toxicants, the concentration which will not be acutely toxic to the most sensitive life stages is the chronically safe concentration for fish, and that the most sensitive life stages are the embryos and fry." Critical life stage exposure was considered to be exposure of the embryos during most, preferably all, of the embryogenic (incubation) period, and exposure of the fry for 30 days post-hatch for warm water fish with embryogenic periods ranging from one-to-fourteen days, and for 60 days post-hatch for fish with longer embryogenic periods. They concluded that in the majority of cases, the maximum acceptable toxicant concentration (MATC) could be estimated from the results of exposure of the embryos during incubation, and the larvae for 30 days post-hatch.

2.1.7 Because of the high cost of full life-cycle fish toxicity tests and the emerging consensus that the ELS test data usually would be adequate for estimating chronically safe concentrations, there was a rapid shift by aquatic toxicologists to 30- to 90-day ELS toxicity tests for estimating chronically safe concentrations in the late 1970s. In 1980, USEPA adopted the policy that ELS test data could be used in establishing water quality criteria if data from full life-cycle tests were not available (USEPA, 1980a).

2.1.8 Published reports of the results of ELS tests indicate that the relative sensitivity of growth and survival as endpoints may be species dependent, toxicant dependent, or both. Ward and Parrish (1980) examined the literature on ELS tests that used embryos and juveniles of the sheepshead minnow, *Cyprinodon variegatus*, and found that growth was not a statistically sensitive indicator of toxicity in 16 of 18 tests. They suggested that the ELS tests be shortened to 14 days posthatch and that growth be eliminated as an indicator of toxic effects.

2.1.9 In a review of the literature on 173 fish full life-cycle and ELS tests performed to determine the chronically safe concentrations of a wide variety of toxicants, such as metals, pesticides, organics, inorganics, detergents, and complex effluents, Woltering (1984) found that at the lowest effect concentration, significant reductions were observed in fry survival in 57%, fry growth in 36%, and egg hatchability in 19% of the tests. He also found that fry survival and growth were very often equally sensitive, and concluded that the growth response could be deleted from routine application of the ELS tests. The net result would be a significant reduction in the duration and cost of screening tests with no appreciable impact on estimating MATCs for chemical hazard assessments. Benoit et al. (1982), however, found larval growth to be the most significant measure of effect and survival to be equally or less sensitive than growth in early life-stage tests with four organic chemicals.

2.1.10 Efforts to further reduce the length of partial life-cycle toxicity tests for fish without compromising their predictive value have resulted in the development of an eight-day, embryo-larval survival and teratogenicity test for fish and other aquatic vertebrates (USEPA, 1981; Birge et al.,

1985), and a seven-day larval survival and growth test (Norberg and Mount, 1985).

2.1.11 The similarity of estimates of chronically safe concentrations of toxicants derived from short-term, embryo-larval survival and teratogenicity tests to those derived from full life-cycle tests has been demonstrated by Birge et al. (1981), Birge and Cassidy (1983), and Birge et al. (1985).

2.1.12 Use of a seven-day, fathead minnow, *Pimephales promelas*, larval survival and growth test was first proposed by Norberg and Mount at the 1983 annual meeting of the Society for Environmental Toxicology and Chemistry (Norberg and Mount, 1983). This test was subsequently used by Mount and associates in field demonstrations at Lima, Ohio (USEPA, 1984), and at many other locations (USEPA, 1985c, USEPA, 1985d; USEPA, 1985e; USEPA, 1986a; USEPA, 1986b; USEPA, 1986c; USEPA, 1986d). Growth was frequently found to be more sensitive than survival in determining the effects of complex effluents.

2.1.13 Norberg and Mount (1985) performed three single toxicant fathead minnow larval growth tests with zinc, copper, and DURSIBAN®, using dilution water from Lake Superior. The results were comparable to, and had confidence intervals that overlapped with, chronic values reported in the literature for both ELS and full life-cycle tests.

2.1.14 USEPA (1987b) and USEPA (1987c) adapted the fathead minnow larval growth and survival test for use with the sheepshead minnow and the inland silverside, respectively. When daily renewal 7-day sheepshead minnow larval growth and survival tests and 28-day ELS tests were performed with industrial and municipal effluents, growth was more sensitive than survival in seven out of 12 larval growth and survival tests, equally sensitive in four tests, and less sensitive in only one test. In four cases, the ELS test may have been three to 10 times more sensitive to effluents than the larval growth and survival test. In tests using copper, the No Observable Effect Concentrations (NOECs) were the same for both types of test, and growth was the most sensitive endpoint for both. In a four laboratory comparison, six of seven tests produced identical NOECs for survival and growth (USEPA, 1987a). Data indicate that the inland silverside is at least equally sensitive or more sensitive to effluents and single compounds than the sheepshead minnow, and can be tested over a wider salinity range, 5-30‰ (USEPA, 1987a).

2.1.15 Lussier et al. (1985) and USEPA (1987e) determined that survival and growth are often as sensitive as reproduction in 28-day life-cycle tests with the mysid, *Mysidopsis bahia*.

2.1.16 Nacci and Jackim (1985) and USEPA (1987g) compared the results from the sea urchin fertilization test, using organic compounds, with results from acute toxicity tests using the freshwater organisms, fathead minnows, *Pimephales promelas*, and *Daphnia magna*. The test was also compared to acute toxicity tests using Atlantic silverside, *Menidia menidia*, and the mysid, *Mysidopsis bahia*, and five metals. For six of the eight organic compounds, the results of the fertilization test and the acute toxicity test correlated well ($r^2 = 0.85$). However, the results of the fertilization test with the five metals did not correlate well with the results from the acute tests.

2.1.17 USEPA (1987f) evaluated two industrial effluents containing heavy metals, five industrial effluents containing organic chemicals (including dyes and pesticides), and 15 domestic wastewaters using the two-day red macroalga, *Champia parvula*, sexual reproduction test. Nine single compounds were used to compare the effects on sexual reproduction using a two-week exposure and a two-day exposure. For six of the nine compounds tested, the chronic values were the same for both tests.

2.1.18 The use of short-term toxicity tests in the NPDES Program is especially attractive because they provide a more direct estimate of the safe concentrations of effluents in receiving waters than was provided by acute toxicity tests, at an only slightly increased level of effort, compared to the fish full life-cycle chronic and 28-day ELS tests and the 28-day mysid life-cycle test.

2.2 TYPES OF TESTS

2.2.1 The selection of the test type will depend on the NPDES permit requirements, the objectives of the test, the available resources, the requirements of the test organisms, and effluent characteristics such as fluctuations in effluent toxicity.

2.2.2 Effluent chronic toxicity is generally measured using a multi-concentration, or definitive test, consisting of a control and a minimum of five effluent concentrations. The tests are designed to provide dose-response information, expressed as the percent effluent concentration that affects the hatchability, gross morphological abnormalities, survival, growth, and/or reproduction within the prescribed period of time (one hour and 20 minutes to nine days). The results of the tests are expressed in terms of either the highest concentration that has no statistically significant observed effect on those responses when compared to the controls or the estimated concentration that causes a specified percent reduction in responses versus the controls.

2.2.3 Use of pass/fail tests consisting of a single effluent concentration (e.g., the receiving water concentration or RWC) and a control is **not recommended**. If the NPDES permit has a whole effluent toxicity limit for acute toxicity at the RWC, it is prudent to use that permit limit as the midpoint of a series of five effluent concentrations. This will ensure that there is sufficient information on the dose-response relationship. For example, the effluent concentrations utilized in a test may be: (1) 100% effluent, (2) $(RWC + 100)/2$, (3) RWC, (4) $RWC/2$, and (5) $RWC/4$. More specifically, if the $RWC = 50\%$, the effluent concentrations used in the toxicity test would be 100%, 75%, 50%, 25%, and 12.5%.

2.2.4 Receiving (ambient) water toxicity tests commonly employ two treatments, a control and the undiluted receiving water, but may also consist of a series of receiving water dilutions.

2.2.5 A negative result from a chronic toxicity test does not preclude the presence of toxicity. Also, because of the potential temporal variability in the toxicity of effluents, a negative test result with a particular sample

does not preclude the possibility that samples collected at some other time might exhibit chronic toxicity.

2.2.6 The frequency with which chronic toxicity tests are conducted under a given NPDES permit is determined by the regulatory agency on the basis of factors such as the variability and degree of toxicity of the waste, production schedules, and process changes.

2.2.7 Tests recommended for use in this methods manual may be static non-renewal or static renewal. Individual methods specify which static type of test is to be conducted.

2.3 STATIC TESTS

2.3.1 Static non-renewal tests - The test organisms are exposed to the same test solution for the duration of the test.

2.3.2 Static-renewal tests - The test organisms are exposed to a fresh solution of the same concentration of sample every 24 h or other prescribed interval, either by transferring the test organisms from one test chamber to another, or by replacing all or a portion of solution in the test chambers.

2.4 ADVANTAGES AND DISADVANTAGES OF TOXICITY TEST TYPES

2.4.1 STATIC NON-RENEWAL, SHORT-TERM TOXICITY TESTS:

Advantages:

1. Simple and inexpensive
2. Very cost effective in determining compliance with permit conditions.
3. Limited resources (space, manpower, equipment) required; would permit staff to perform many more tests in the same amount of time.
4. Smaller volume of effluent required than for static renewal or flow-through tests.

Disadvantages:

1. Dissolved oxygen (DO) depletion may result from high chemical oxygen demand (COD), biological oxygen demand (BOD), or metabolic wastes.
2. Possible loss of toxicants through volatilization and/or adsorption to the exposure vessels.
3. Generally less sensitive than static renewal because the toxic substances may degrade or be adsorbed, thereby reducing the apparent toxicity. Also, there is less chance of detecting slugs of toxic wastes, or other temporal variations in waste properties.

2.4.2 STATIC RENEWAL, SHORT-TERM TOXICITY TESTS:

Advantages:

1. Reduced possibility of DO depletion from high COD and/or BOD, or ill effects from metabolic wastes from organisms in the test solutions.

2. Reduced possibility of loss of toxicants through volatilization and/or adsorption to the exposure vessels.
3. Test organisms that rapidly deplete energy reserves are fed when the test solutions are renewed, and are maintained in a healthier state.

Disadvantages:

1. Require greater volume of effluent than non-renewal tests.
2. Generally less chance of temporal variations in waste properties.

SECTION 3
HEALTH AND SAFETY

3.1 GENERAL PRECAUTIONS

3.1.1 Each laboratory should develop and maintain an effective health and safety program, requiring an ongoing commitment by the laboratory management and includes: (1) a safety officer with the responsibility and authority to develop and maintain a safety program; (2) the preparation of a formal, written, health and safety plan, which is provided to the laboratory staff; (3) an ongoing training program on laboratory safety; and (4) regularly scheduled, documented, safety inspections.

3.1.2 Collection and use of effluents in toxicity tests may involve significant risks to personal safety and health. Personnel collecting effluent samples and conducting toxicity tests should take all safety precautions necessary for the prevention of bodily injury and illness which might result from ingestion or invasion of infectious agents, inhalation or absorption of corrosive or toxic substances through skin contact, and asphyxiation due to a lack of oxygen or the presence of noxious gases.

3.1.3 Prior to sample collection and laboratory work, personnel should determine that all necessary safety equipment and materials have been obtained and are in good condition.

3.1.4 Guidelines for the handling and disposal of hazardous materials must be strictly followed.

3.2 SAFETY EQUIPMENT

3.2.1 PERSONAL SAFETY GEAR

3.2.1.1 Personnel must use safety equipment, as required, such as rubber aprons, laboratory coats, respirators, gloves, safety glasses, hard hats, and safety shoes. Plastic netting on glass beakers, flasks and other glassware minimizes breakage and subsequent shattering of the glass.

3.2.2 LABORATORY SAFETY EQUIPMENT

3.2.2.1 Each laboratory (including mobile laboratories) should be provided with safety equipment such as first aid kits, fire extinguishers, fire blankets, emergency showers, chemical spill clean-up kits, and eye fountains.

3.2.2.2 Mobile laboratories should be equipped with a telephone to enable personnel to summon help in case of emergency.

3.3 GENERAL LABORATORY AND FIELD OPERATIONS

3.3.1 Work with effluents should be performed in compliance with accepted rules pertaining to the handling of hazardous materials (see safety manuals

listed in Section 3, Health and Safety, Subsection 3.5). It is recommended that personnel collecting samples and performing toxicity tests should not work alone.

3.3.2 Because the chemical composition of effluents is usually only poorly known, they should be considered as potential health hazards, and exposure to them should be minimized. Fume and canopy hoods over the toxicity test areas must be used whenever possible.

3.3.3 It is advisable to cleanse exposed parts of the body immediately after collecting effluent samples.

3.3.4 All containers should be adequately labeled to indicate their contents.

3.3.5 Staff should be familiar with safety guidelines on Material Safety Data Sheets for reagents and other chemicals purchased from suppliers. Incompatible materials should not be stored together. Good housekeeping contributes to safety and reliable results.

3.3.6 Strong acids and volatile organic solvents employed in glassware cleaning must be used in a fume hood or under an exhaust canopy over the work area.

3.3.7 Electrical equipment or extension cords not bearing the approval of Underwriter Laboratories must not be used. Ground-fault interrupters must be installed in all "wet" laboratories where electrical equipment is used.

3.3.8 Mobile laboratories should be properly grounded to protect against electrical shock.

3.4 DISEASE PREVENTION

3.4.1 Personnel handling samples which are known or suspected to contain human wastes should be immunized against tetanus, typhoid fever, polio, and hepatitis B.

3.5 SAFETY MANUALS

3.5.1 For further guidance on safe practices when collecting effluent samples and conducting toxicity tests, check with the permittee and consult general safety manuals, including USEPA (1986e), and Walters and Jameson (1984).

3.6 WASTE DISPOSAL

3.6.1 Wastes generated during toxicity testing must be properly handled and disposed of in an appropriate manner. Each testing facility will have its own waste disposal requirements based on local, state and Federal rules and regulations. It is extremely important that these rules and regulations be known, understood, and complied with by all persons responsible for, or otherwise involved in, performing toxicity testing activities. Local fire officials should be notified of any potentially hazardous conditions.

SECTION 4
QUALITY ASSURANCE

4.1 INTRODUCTION

4.1.1 Development and maintenance of a toxicity test laboratory quality assurance (QA) program (USEPA, 1991b) requires an ongoing commitment by laboratory management. Each toxicity test laboratory should (1) appoint a quality assurance officer with the responsibility and authority to develop and maintain a QA program, (2) prepare a quality assurance plan with stated data quality objectives (DQOs), (3) prepare written descriptions of laboratory standard operating procedures (SOPs) for culturing, toxicity testing, instrument calibration, sample chain-of-custody procedures, laboratory sample tracking system, glassware cleaning, etc., and (4) provide an adequate, qualified technical staff for culturing and toxicity testing the organisms, and suitable space and equipment to assure reliable data.

4.1.2 QA practices for toxicity testing laboratories must address all activities that affect the quality of the final effluent toxicity data, such as: (1) effluent sampling and handling; (2) the source and condition of the test organisms; (3) condition of equipment; (4) test conditions; (5) instrument calibration; (6) replication; (7) use of reference toxicants; (8) record keeping; and (9) data evaluation.

4.1.3 Quality control practices, on the other hand, consist of the more focused, routine, day-to-day activities carried out within the scope of the overall QA program. For more detailed discussion of quality assurance and general guidance on good laboratory practices and laboratory evaluation related to toxicity testing, see FDA (1978); USEPA (1979d); USEPA (1980b); USEPA (1980c); USEPA (1991c); DeWoskin (1984); and Taylor (1987).

4.1.4 Guidelines for the evaluation of laboratory performing toxicity tests and laboratory evaluation criteria are found in USEPA (1991c).

4.2 FACILITIES, EQUIPMENT, AND TEST CHAMBERS

4.2.1 Separate test organism culturing and toxicity testing areas should be provided to avoid possible loss of cultures due to cross-contamination. Ventilation systems should be designed and operated to prevent recirculation or leakage of air from chemical analysis laboratories or sample storage and preparation areas into organism culturing or testing areas, and from testing and sample preparation areas into culture rooms.

4.2.2 Laboratory and toxicity test temperature control equipment must be adequate to maintain recommended test water temperatures. Recommended materials must be used in the fabrication of the test equipment which comes in contact with the effluent (see Section 5, Facilities, Equipment, and Supplies; and specific toxicity test method).

4.3 TEST ORGANISMS

4.3.1 The test organisms used in the procedures described in this manual are the sheepshead minnow, *Cyprinodon variegatus*; the inland silverside, *Menidia beryllina*; the mysid, *Mysidopsis bahia*; the sea urchin, *Arbacia punctulata*; and the red macroalga, *Champia parvula*. The organisms used should be disease-free and appear healthy, behave normally, feed well, and have low mortality in cultures, during holding, and in test control. Test organisms should be positively identified to species (see Section 6, Test Organisms).

4.4 LABORATORY WATER USED FOR CULTURING AND TEST DILUTION WATER

4.4.1 The quality of water used for test organism culturing and for dilution water used in toxicity tests is extremely important. Water for these two uses should come from the same source. The dilution water used in effluent toxicity tests will depend on the objectives of the study and logistical constraints, as discussed in Section 7, Dilution Water. The dilution water used in the toxicity tests may be natural seawater, hypersaline brine (100%) prepared from natural seawater, or artificial seawater prepared from commercial sea salts, such as FORTY FATHOMS® or HW MARINEMIX®, if recommended in the method. GP2 synthetic seawater, made from reagent grade chemical salts (30%) in conjunction with natural seawater, may also be used if recommended. Hypersaline brine and artificial seawater can be used with *Champia parvula* only if they are accompanied by at least 50% natural seawater. Types of water are discussed in Section 5, Facilities, Equipment, and Supplies. Water used for culturing and test dilution water should be analyzed for toxic metals and organics at least annually or whenever difficulty is encountered in meeting minimum acceptability criteria for control survival and reproduction or growth. The concentration of the metals, Al, As, Cr, Co, Cu, Fe, Pb, Ni, Zn, expressed as total metal, should not exceed 1 µg/L each, and Cd, Hg, and Ag, expressed as total metal, should not exceed 100 ng/L each. Total organochlorine pesticides plus PCBs should be less than 50 ng/L (APHA, 1992). Pesticide concentrations should not exceed USEPA's National Ambient Water Quality chronic criteria values where available.

4.5 EFFLUENT AND RECEIVING WATER SAMPLING AND HANDLING

4.5.1 Sample holding times and temperatures of effluent samples collected for on-site and off-site testing must conform to conditions described in Section 8, Effluent and Receiving Water Sampling, Sample Handling, and Sample Preparation for Toxicity Tests.

4.6 TEST CONDITIONS

4.6.1 Water temperature and salinity must be maintained within the limits specified for each test. The temperature of test solutions must be measured by placing the thermometer or probe directly into the test solutions, or by placing the thermometer in equivalent volumes of water in surrogate vessels positioned at appropriate locations among the test vessels. Temperature should be recorded continuously in at least one vessel during the duration of each test. Test solution temperatures must be maintained within the limits

specified for each test. DO concentrations and pH should be checked at the beginning of the test and daily throughout the test period.

4.7 QUALITY OF TEST ORGANISMS

4.7.1 If the laboratory performs short-term chronic toxicity tests routinely but does not have an ongoing test organism culturing program and must obtain the test organisms from an outside source, the sensitivity of a batch of test organisms must be determined with a reference toxicant in a short-term chronic toxicity test performed monthly (see Section 4, Quality Assurance, Subsections 4.14, 4.15, 4.16, and 4.17). Where acute or short-term chronic toxicity tests are performed with effluents or receiving waters using test organisms obtained from outside the test laboratory, concurrent toxicity tests of the same type must be performed with a reference toxicant, unless the test organism supplier provides control chart data from at least the last five monthly short-term chronic toxicity tests using the same reference toxicants and test conditions (see Section 6, Test Organisms).

4.7.2 The supplier should certify the species identification of the test organisms, and provide the taxonomic reference (citation and page) or name(s) of the taxonomic expert(s) consulted.

4.7.3 If the laboratory maintains breeding cultures, the sensitivity of the offspring should be determined in a short-term chronic toxicity test performed with a reference toxicant at least once each month (see Section 4, Quality Assurance, Subsection 4.14, 4.15, 4.16, and 4.17). If preferred, this reference toxicant test may be performed concurrently with an effluent toxicity test. However, if a given species of test organism produced by inhouse cultures is used only monthly, or less frequently in toxicity tests, a reference toxicant test must be performed concurrently with each short-term chronic effluent and/or receiving water toxicity test.

4.7.4 If a routine reference toxicant test fails to meet acceptability criteria, the test must be immediately repeated. If the failed reference toxicant test was being performed concurrently with an effluent or receiving water toxicity test, both tests must be repeated (For exception, see Section 4, Quality Assurance, Subsection 4.16.5).

4.8 FOOD QUALITY

4.8.1 The nutritional quality of the food used in culturing and testing fish and invertebrates is an important factor in the quality of the toxicity test data. This is especially true for the unsaturated fatty acid content of brine shrimp nauplii, *Artemia*. Problems with the nutritional suitability of the food will be reflected in the survival, growth, and reproduction of the test organisms in cultures and toxicity tests. *Artemia* cysts and other foods must be obtained as described in Section 5, Facilities, Equipment, and Supplies.

4.8.2 Problems with the nutritional suitability of food will be reflected in the survival, growth, and reproduction of the test organisms in cultures and toxicity tests. If a batch of food is suspected to be defective, the performance of organisms fed with the new food can be compared with the

performance of organisms fed with a food of known quality in side-by-side tests. If the food is used for culturing, its suitability should be determined using a short-term chronic test which will determine the affect of food quality on growth or reproduction of each of the relevant test species in culture, using four replicates with each food source. Where applicable, foods used only in chronic toxicity tests can be compared with a food of known quality in side-by-side, multi-concentration chronic tests, using the reference toxicant regularly employed in the laboratory QA program. For list of commercial sources of *Artemia* cysts, see Table 2 of Section 5, Facilities, Equipment, and Supplies.

4.8.3 New batches of food used in culturing and testing should be analyzed for toxic organics and metals or whenever difficulty is encountered in meeting minimum acceptability criteria for control survival and reproduction or growth. If the concentration of total organochlorine pesticides exceeds $0.15 \mu\text{g/g}$ wet weight, or the concentration of total organochlorine pesticides plus PCBs exceeds $0.30 \mu\text{g/g}$ wet weight, or toxic metals (Al, As, Cr, Cd, Cu, Pb, Ni, Zn, expressed as total metal) exceed $20 \mu\text{g/g}$ wet weight, the food should not be used (for analytical methods, see AOAC, 1990; and USDA, 1989).

For foods (e.g., YCT) which are used to culture and test organisms, the quality of the food should meet the requirements for the laboratory water used for culturing and test dilution water as described in Section 4.4 above.

4.9 ACCEPTABILITY OF CHRONIC TOXICITY TESTS

4.9.1 The results of the sheepshead minnow, *Cyprinodon variegatus*, inland silverside, *Menidia beryllina*, or mysid, *Mysidopsis bahia*, tests are acceptable if survival in the controls is 80% or greater. The sea urchin, *Arbacia punctulata*, test requires control egg fertilization equal to or exceeding 50%. However, greater than 90% fertilization may result in masking toxic responses. The red macroalga, *Champia parvula*, test is acceptable if survival is 100%, and the mean number of cystocarps per plant should equal or exceed 10. If the sheepshead minnow, *Cyprinodon variegatus*, larval survival and growth test is begun with less-than-24-h old larvae, the mean dry weight of the surviving larvae in the control chambers at the end of the test should equal or exceed 0.60 mg, if the weights are determined immediately, or 0.50 mg if the larvae are preserved in a 4% formalin or 70% ethanol solution. If the inland silverside, *Menidia beryllina*, larval survival and growth test is begun with larvae seven days old, the mean dry weight of the surviving larvae in the control chambers at the end of the test should equal or exceed 0.50 mg, if the weights are determined immediately, or 0.43 mg if the larvae are preserved in a 4% formalin or 70% ethanol solution. The mean mysid dry weight of survivors should be at least 0.20 mg. Automatic or hourly feeding will generally provide control mysids with a dry weight of 0.30 mg. At least 50% of the females should bear eggs at the end of the test, but mysid fecundity is not a factor in test acceptability. However, fecundity must equal or exceed 50% to be used as an endpoint in the test. If these criteria are not met, the test must be repeated.

4.9.2 An individual test may be conditionally acceptable if temperature, DO, and other specified conditions fall outside specifications, depending on the

degree of the departure and the objectives of the tests (see test conditions and test acceptability criteria summaries). The acceptability of the test will depend on the experience and professional judgment of the laboratory investigator and the reviewing staff of the regulatory authority. Any deviation from test specifications must be noted when reporting data from a test.

4.10 ANALYTICAL METHODS

4.10.1 Routine chemical and physical analyses for culture and dilution water, food, and test solutions must include established quality assurance practices outlined in USEPA methods manuals (USEPA, 1979a and USEPA, 1979b).

4.10.2 Reagent containers should be dated and catalogued when received from the supplier, and the shelf life should not be exceeded. Also, working solutions should be dated when prepared, and the recommended shelf life should be observed.

4.11 CALIBRATION AND STANDARDIZATION

4.11.1 Instruments used for routine measurements of chemical and physical parameters, such as pH, DO, temperature, conductivity, and salinity, must be calibrated and standardized according to instrument manufacturers procedures as indicated in the general section on quality assurance (see USEPA Methods 150.1, 360.1, 170.1, and 120.1 in USEPA, 1979b). Calibration data are recorded in a permanent log book.

4.11.2 Wet chemical methods used to measure hardness, alkalinity, and total residual chlorine, must be standardized prior to use each day according to the procedures for those specific USEPA methods (see USEPA Methods 130.2 and 310.1 in USEPA, 1979b).

4.12 REPLICATION AND TEST SENSITIVITY

4.12.1 The sensitivity of the tests will depend in part on the number of replicates per concentration, the significance level selected, and the type of statistical analysis. If the variability remains constant, the sensitivity of the test will increase as the number of replicates is increased. The minimum recommended number of replicates varies with the objectives of the test and the statistical method used for analysis of the data.

4.13 VARIABILITY IN TOXICITY TEST RESULTS

4.13.1 Factors which can affect test success and precision include: (1) the experience and skill of the laboratory analyst; (2) test organism age, condition, and sensitivity; (3) dilution water quality; (4) temperature control; (5) and the quality and quantity of food provided. The results will depend upon the species used and the strain or source of the test organisms, and test conditions, such as temperature, DO, food, and water quality. The repeatability or precision of toxicity tests is also a function of the number of test organisms used at each toxicant concentration. Jensen (1972) discussed the relationship between sample size (number of fish) and the

standard error of the test, and considered 20 fish per concentration as optimum for Probit Analysis.

4.14 TEST PRECISION

4.14.1 The ability of the laboratory personnel to obtain consistent, precise results must be demonstrated with reference toxicants before they attempt to measure effluent toxicity. The single-laboratory precision of each type of test to be used in a laboratory should be determined by performing at least five or more tests with a reference toxicant.

4.14.2 Test precision can be estimated by using the same strain of organisms under the same test conditions, and employing a known toxicant, such as a reference toxicant.

4.14.3 Interlaboratory precision of chronic toxicity tests using two reference toxicants with the mysid, *Mysidopsis bahia*, and the inland silverside, *Menidia beryllina*, is listed in Table 1. Additional precision data for each of the tests described in this manual are presented in the sections describing the individual test methods.

4.14.4 Additional information on toxicity test precision is provided in the Technical Support Document for Water Quality-based Toxic Control (see pp. 2-4, and 11-15 in USEPA, 1991a).

4.14.5 In cases where the test data are used in Probit Analysis or other point estimation techniques (see Section 9, Chronic Toxicity Test Endpoints and Data Analysis), precision can be described by the mean, standard deviation, and relative standard deviation (percent coefficient of variation, or CV) of the calculated endpoints from the replicated tests. In cases where the test data are used in the Linear Interpolation Method, precision can be estimated by empirical confidence intervals derived by using the ICPIN Method (see Section 9, Chronic Toxicity Test Endpoints and Data Analysis). However, in cases where the results are reported in terms of the No-Observed-Effect-Concentration (NOEC) and Lowest-Observed-Effect-Concentration (LOEC) (see Section 9, Chronic Toxicity Test Endpoints and Data Analysis), precision can only be described by listing the NOEC-LOEC interval for each test. It is not possible to express precision in terms of a commonly used statistic. However, when all tests of the same toxicant yield the same NOEC-LOEC interval, maximum precision has been attained. The "true" no effect concentration could fall anywhere within the interval, $NOEC \pm (LOEC \text{ minus } NOEC)$.

4.14.6 It should be noted here that the dilution factor selected for a test determines the width of the NOEC-LOEC interval and the inherent maximum precision of the test. As the absolute value of the dilution factor decreases, the width of the NOEC-LOEC interval increases, and the inherent maximum precision of the test decreases. When a dilution factor of 0.3 is used, the NOEC could be considered to have a relative uncertainty as high as $\pm 300\%$. With a dilution factor of 0.5, the NOEC could be considered to have a relative variability of $\pm 100\%$. As a result of the variability of different dilution factors, **USEPA recommends the use of a ≥ 0.5 dilution factor.** Other factors which can affect test precision include: test organism age, condition, and sensitivity; temperature control; and feeding.

TABLE 1. NATIONAL INTERLABORATORY STUDY OF CHRONIC TOXICITY TEST PRECISION, 1991: SUMMARY OF RESPONSES USING TWO REFERENCE TOXICANTS^{1,2}

Organism	Endpoint	No. Labs	KCl(mg/L) ⁴	SD	CV(%) ³
<i>Mysidopsis bahia</i>	Survival, NOEC	34	NA	NA	NA
	Growth, IC25	26	480	3.47	28.9
	Growth, IC50	22	656	3.17	19.3
	Growth, NOEC	32	NA	NA	NA
	Fecundity, NOEC	25	NA	NA	NA
Organism	Endpoint	No. Labs	Cu(mg/L) ⁴	SD	CV(%) ³
<i>Menidia beryllina</i>	Survival, NOEC	19	NA	NA	NA
	Growth, IC25	13	0.144	1.56	43.5
	Growth, IC50	12	0.180	1.87	41.6
	Growth, NOEC	17	NA	NA	NA

- ¹ From a national study of interlaboratory precision of toxicity test data performed in 1991 by the Environmental Monitoring Systems Laboratory-Cincinnati, U.S. Environmental Protection Agency, Cincinnati, OH 45268. Participants included federal, state, and private laboratories engaged in NPDES permit compliance monitoring.
- ² Static renewal test, using 25‰ modified GP2 artificial seawater.
- ³ Percent coefficient of variation = (standard deviation X 100)/mean.
- ⁴ Expressed as mean.

4.15 DEMONSTRATING ACCEPTABLE LABORATORY PERFORMANCE

4.15.1 It is a laboratory's responsibility to demonstrate its ability to obtain consistent, precise results with reference toxicants before it performs toxicity tests with effluents for permit compliance purposes. To meet this requirement, the intralaboratory precision, expressed as percent coefficient of variation (CV%), of each type of test to be used in a laboratory should be determined by performing five or more tests with different batches of test organisms, using the same reference toxicant, at the same concentrations, with the same test conditions (i.e., the same test duration, type of dilution water, age of test organisms, feeding, etc.), and same data analysis methods. A reference toxicant concentration series (0.5 or higher) should be selected that will consistently provide partial mortalities at two or more concentrations.

4.16 DOCUMENTING ONGOING LABORATORY PERFORMANCE

4.16.1 Satisfactory laboratory performance is demonstrated by performing at least one acceptable test per month with a reference toxicant for each

toxicity test method commonly used in the laboratory. For a given test method, successive tests must be performed with the same reference toxicant, at the same concentrations, in the same dilution water, using the same data analysis methods. Precision may vary with the test species, reference toxicant, and type of test.

4.16.2 A control chart should be prepared for each combination of reference toxicant, test species, test conditions, and endpoints. Toxicity endpoints from five or six tests are adequate for establishing the control charts. Successive toxicity endpoints (NOECs, IC25s, LC50s, etc.) should be plotted and examined to determine if the results (X_i) are within prescribed limits (Figure 1). The types of control charts illustrated (see USEPA, 1979a) are used to evaluate the cumulative trend of results from a series of samples. For endpoints that are point estimates (LC50s and IC25s), the cumulative mean (\bar{X}) and upper and lower control limits ($\pm 2S$) are re-calculated with each successive test result. Endpoints from hypothesis tests (NOEC, NOAEC) from each test are plotted directly on the control chart. The control limits would consist of one concentration interval above and below the concentration representing the central tendency. After two years of data collection, or a minimum of 20 data points, the control (cusum) chart should be maintained using only the 20 most recent data points.

4.16.3 The outliers, which are values falling outside the upper and lower control limits, and trends of increasing or decreasing sensitivity, are readily identified. In the case of endpoints that are point estimates (LC50s and IC25s), at the $P_{0.05}$ probability level, one in 20 tests would be expected to fall outside of the control limits by chance alone. If more than one out of 20 reference toxicant tests fall outside the control limits, the effluent toxicity tests conducted during the month in which the second reference toxicant test failed are suspect, and should be considered as provisional and subject to careful review. Control limits for the NOECs will also be exceeded occasionally, regardless of how well a laboratory performs.

4.16.4 If the toxicity value from a given test with a reference toxicant fall well outside the expected range for the test organisms when using the standard dilution water and other test conditions, the sensitivity of the organisms and the overall credibility of the test system are suspect. In this case, the test procedure should be examined for defects and should be repeated with a different batch of test organisms.

4.16.5 Performance should improve with experience, and the control limits for endpoints that are point estimates should gradually narrow. However, control limits of $\pm 2S$ will be exceeded 5% of the time by chance alone, regardless of how well a laboratory performs. Highly proficient laboratories which develop very narrow control limits may be unfairly penalized if a test result which falls just outside the control limits is rejected *de facto*. For this reason, the width of the control limits should be considered by the permitting authority in determining whether the outliers should be rejected.

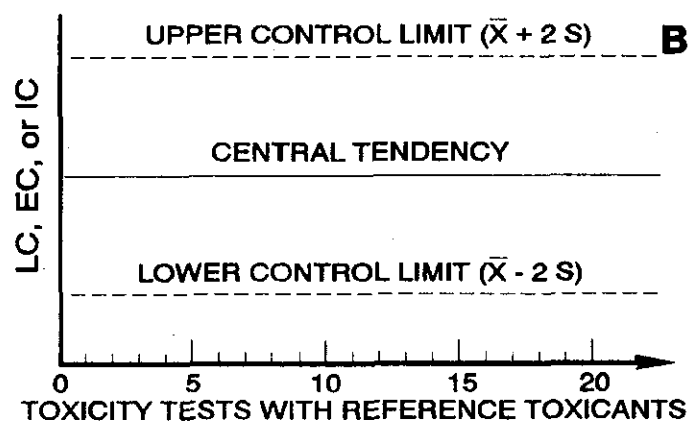
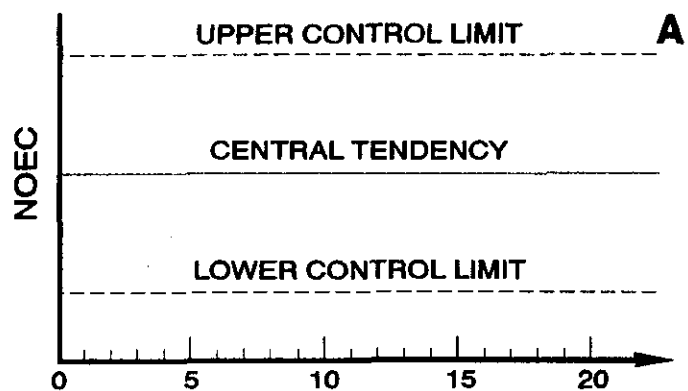

$$\bar{X} = \frac{\sum_{i=1}^n X_i}{n}$$

$$S = \sqrt{\frac{\sum_{i=1}^n X_i^2 - \frac{(\sum_{i=1}^n X_i)^2}{n}}{n-1}}$$

Where: X_i = Successive toxicity values from toxicity tests.

n = Number of tests.

\bar{X} = Mean toxicity value.

S = Standard deviation.

Figure 1. Control (cusum) charts. (A) hypothesis testing results; (B) point estimates (LC, EC, or IC).

4.17 REFERENCE TOXICANTS

4.17.1 Reference toxicants such as sodium chloride (NaCl), potassium chloride (KCl), cadmium chloride (CdCl₂), copper sulfate (CuSO₄), sodium dodecyl sulfate (SDS), and potassium dichromate (K₂Cr₂O₇), are suitable for use in the NPDES Program and other Agency programs requiring aquatic toxicity tests. EMSL-Cincinnati plans to release USEPA-certified solutions of cadmium and copper for use as reference toxicants, through cooperative research and development agreements with commercial suppliers, and will continue to develop additional reference toxicants for future release. Interested parties can determine the availability of "EPA Certified" reference toxicants by checking the EMSL-Cincinnati electronic bulletin board, using a modem to access the following telephone number: 513-569-7610. Standard reference materials also can be obtained from commercial supply houses, or can be prepared inhouse using reagent grade chemicals. The regulatory agency should be consulted before reference toxicant(s) are selected and used.

4.18 RECORD KEEPING

4.18.1 Proper record keeping is important. A complete file must be maintained for each individual toxicity test or group of tests on closely related samples. This file must contain a record of the sample chain-of-custody; a copy of the sample log sheet; the original bench sheets for the test organism responses during the toxicity test(s); chemical analysis data on the sample(s); detailed records of the test organisms used in the test(s), such as species, source, age, date of receipt, and other pertinent information relating to their history and health; information on the calibration of equipment and instruments; test conditions employed; and results of reference toxicant tests. Laboratory data should be recorded on a real-time basis to prevent the loss of information or inadvertent introduction of errors into the record. Original data sheets should be signed and dated by the laboratory personnel performing the tests.

4.18.2 The regulatory authority should retain records pertaining to discharge permits. Permittees are required to retain records pertaining to permit applications and compliance for a minimum of 3 years [40 CFR 122.41(j)(2)].

4.19 VIDEO TAPES OF USEPA CULTURE AND TOXICITY TEST METHODS

Three video-based training packages are available from National Technical Information Service (NTIS), Department of Commerce, 5285 Port Royal Road, Springfield, VA 22161. Credit card orders can be placed by calling toll-free (800) 788-6282, or by FAX at 703-321-8547, or by mail at the above address. For other information call 703-487-4650.

1. Order # A18545: Toxicity Test Methods for the Red macroalga, *Champia parvula*; the Sheepshead Minnow, *Cyprinodon variegatus*; the inland silverside, *Menidia beryllina*; and the Sea Urchin, *Arbacia punctulata*. Price \$85.00.

2. Order # A18657: Mysids, *Mysidopsis bahia*, Culture and Toxicity Test.
Price \$75.00.

4.20 SUPPLEMENTAL REPORTS FOR TRAINING VIDEO TAPES

4.20.1 Ordering information: USEPA, Center for Environmental Research
Information, Cincinnati, OH 45268.

4.20.1.1 Sheepshead minnow, *Cyprinodon variegatus*, and inland silverside,
Menidia beryllina, larval survival and growth toxicity tests (EPA/600/3-
90/075), 1990.

4.20.1.2 Red algae, *Champia parvula*, sexual reproduction (EPA/600/3-90/076),
1990.

4.20.1.3 Sperm cell test using the sea urchin, *Arbacia punctulata*,
(EPA/600-3-90/077), 1990.

4.20.2 Ordering information: USEPA, Office of Water (EN-336), Washington,
D.C. 20460.

4.20.2.1 Mysids, *Mysidopsis bahia*, survival, growth, and fecundity test
(EPA/505/8-90-006a), 1990.

SECTION 5

FACILITIES, EQUIPMENT, AND SUPPLIES

5.1 GENERAL REQUIREMENTS

5.1.1 Effluent toxicity tests may be performed in a fixed or mobile laboratory. Facilities must include equipment for rearing and/or holding organisms. Culturing facilities for test organisms may be desirable in fixed laboratories which perform large numbers of tests. Temperature control can be achieved using circulating water baths, heat exchangers, or environmental chambers. Water used for rearing, holding, acclimating, and testing organisms may be natural seawater or water made up from hypersaline brine derived from natural seawater, or water made up from reagent grade chemicals (GP2) or commercial (FORTY FATHOMS® or HW MARINEMIX®) artificial sea salts when specifically recommended in the method. Air used for aeration must be free of oil and toxic vapors. Oil-free air pumps should be used where possible. Particulates can be removed from the air using BALSTON® Grade BX or equivalent filters (Balston, Inc., Lexington, Massachusetts), and oil and other organic vapors can be removed using activated carbon filters (BALSTON®, C-1 filter, or equivalent).

5.1.2 The facilities must be well ventilated and free of fumes. Laboratory ventilation systems should be checked to ensure that return air from chemistry laboratories and/or sample handling areas is not circulated to test organism culture rooms or toxicity test rooms, or that air from toxicity test rooms does not contaminate culture areas. Sample preparation, culturing, and toxicity testing areas should be separated to avoid cross-contamination of cultures or toxicity test solutions with toxic fumes. Air pressure differentials between such rooms should not result in a net flow of potentially contaminated air to sensitive areas through open or loosely-fitting doors. Organisms should be shielded from external disturbances.

5.1.3 Materials used for exposure chambers, tubing, etc., which come in contact with the effluent and dilution water, should be carefully chosen. Tempered glass and perfluorocarbon plastics (TEFLON®) should be used whenever possible to minimize sorption and leaching of toxic substances. These materials may be reused following decontamination. Containers made of plastics, such as polyethylene, polypropylene, polyvinyl chloride, TYGON®, etc., may be used as test chambers or to ship, store, and transfer effluents and receiving waters, but they should not be reused unless absolutely necessary, because they might carry over adsorbed toxicants from one test to another, if reused. However, these containers may be repeatedly reused for storing uncontaminated waters such as deionized or laboratory-prepared dilution waters and receiving waters. Glass or disposable polystyrene containers can be used as test chambers. The use of large (≥ 20 L) glass carboys is discouraged for safety reasons.

5.1.4 New plastic products of a type not previously used should be tested for toxicity before initial use by exposing the test organisms in the test system where the material is used. Equipment (pumps, valves, etc.) which cannot be

discarded after each use because of cost, must be decontaminated according to the cleaning procedures listed below (see Section 5, Facilities, Equipment, and Supplies, Subsection 5.3.2). Fiberglass, in addition to the previously mentioned materials, can be used for holding, acclimating, and dilution water storage tanks, and in the water delivery system, but once contaminated with pollutants the fiberglass should not be reused. All material should be flushed or rinsed thoroughly with the test media before using in the test.

5.1.5 Copper, galvanized material, rubber, brass, and lead must not come in contact with culturing, holding, acclimation, or dilution water, or with effluent samples and test solutions. Some materials, such as several types of neoprene rubber (commonly used for stoppers) may be toxic and should be tested before use.

5.1.6 Silicone adhesive used to construct glass test chambers absorbs some organochlorine and organophosphorus pesticides, which are difficult to remove. Therefore, as little of the adhesive as possible should be in contact with water. Extra beads of adhesive inside the containers should be removed.

5.2 TEST CHAMBERS

5.2.1 Test chamber size and shape are varied according to size of the test organism. Requirements are specified in each toxicity test method.

5.3 CLEANING TEST CHAMBERS AND LABORATORY APPARATUS

5.3.1 New plasticware used for sample collection or organism exposure vessels generally does not require thorough cleaning before use. It is sufficient to rinse new sample containers once with dilution water before use. New, disposable, plastic test chambers may have to be rinsed with dilution water before use. New glassware must be soaked overnight in 10% acid (see below) and also should be rinsed well in deionized water and seawater.

5.3.2 All non-disposable sample containers, test vessels, pumps, tanks, and other equipment that has come in contact with effluent must be washed after use to remove surface contaminants, as described below.

1. Soak 15 minutes in tap water and scrub with detergent, or clean in an automatic dishwasher.
2. Rinse twice with tap water.
3. Carefully rinse once with fresh dilute (10% V:V) hydrochloric acid or nitric acid to remove scale, metals and bases. To prepare a 10% solution of acid, add 10 mL of concentrated acid to 90 mL of deionized water.
4. Rinse twice with deionized water.
5. Rinse once with full-strength, pesticide-grade acetone to remove organic compounds (use a fume hood or canopy).
6. Rinse three times with deionized water.

5.3.3 All test chambers and equipment must be thoroughly rinsed with the dilution water immediately prior to use in each test.

5.4 APPARATUS AND EQUIPMENT FOR CULTURING AND TOXICITY TESTS

5.4.1 Apparatus and equipment requirements for culturing and toxicity tests are specified in each toxicity test method. Also, see USEPA, 1993a.

5.4.2 WATER PURIFICATION SYSTEM

5.4.2.1 A good quality deionized water, providing 18 mega-ohm, laboratory grade water, should be available in the laboratory and with sufficient capacity for laboratory needs. Deionized water may be obtained from MILLIPORE® MILLI-Q®, MILLIPORE® QPAK™₂ or equivalent system. If large quantities of high quality deionized water are needed, it may be advisable to supply the laboratory grade water deionizer with preconditioned water from a Culligen®, Continental®, or equivalent.

5.5 REAGENTS AND CONSUMABLE MATERIALS

5.5.1 SOURCES OF FOOD FOR CULTURE AND TOXICITY TESTS

1. Brine Shrimp, *Artemia* sp. cysts -- A list of commercial sources is provided in Table 2.
2. Frozen Adult Brine Shrimp, *Artemia* -- Available from most pet supply shops or from San Francisco Bay Brand, 8239 Enterprise Dr., Newark, CA 94560 (415-792-7200).
3. Flake Food -- TETRAMIN® and BIORIL® or equivalent are available at most pet supply shops.
4. Feeding requirements and other specific foods are indicated in the specific toxicity test method.

5.5.1.1 All food should be tested for nutritional suitability and chemically analyzed for organochlorine pesticides, PCBs, and toxic metals (see Section 4, Quality Assurance).

5.5.2 Reagents and consumable materials are specified in each toxicity test method. Also, see Section 4, Quality Assurance.

5.6 TEST ORGANISMS

5.6.1 Test organisms are obtained from inhouse cultures or commercial suppliers (see specific toxicity test method; Sections 4, Quality Assurance and 6, Test Organisms).

5.7 SUPPLIES

5.7.1 See toxicity test methods (see Sections 11-16) for specific supplies.

TABLE 2. COMMERCIAL SUPPLIERS OF BRINE SHRIMP (*ARTEMIA*) CYSTS^{1,2}

Aquafauna Biomarine
P.O. Box 5
Hawthorne, CA 90250
Tel. (310) 973-5275
Fax. (310) 676-9387
(Great Salt Lake North Arm,
San Francisco Bay)

Argent Chemical
8702 152nd Ave. NE
Redmond, WA 98052
Tel. (800) 426-6258
Tel. (206) 855-3777
Fax. (206) 885-2112
(Platinum Label - San Francisco Bay;
Gold Label - San Francisco Bay,
Brazil; Silver Label - Great
Salt Lake, Australia; Bronze
Label - China, Canada, other)

Bonneville Artemia International, Inc.
P.O. Box 511113
Salt Lake City, UT 84151-1113
Tel. (801) 972-4704
Fax. (801) 972-4795

Ocean Star International
P.O. Box 643
Snowville, UT 84336
Tel. (801) 872-8217
Fax (801) 872-8272
(Great Salt Lake)

Sanders Brine Shrimp Co.
3850 South 540 West
Ogden, UT 84405
Tel. (801) 393-5027
(Great Salt Lake)

Sea Critters Inc.
P.O. Box 1508
Tavernier, FL 33070
Tel. (305) 367-2672

Aquarium Products
180L Penrod Court
Glen Burnie, MD 21061
Tel. (800) 368-2507
Fax. (410) 761-6458
Tel. (301) 761-2100
(Columbia)

INVE Artemia Systems
Oeverstraat 7
B-9200 Baasrode, Belgium
Tel. 011-32-52-331320
Fax. 011-32-52-341205
(For marine species - AF grade)
[small nauplii], UL grade [large
nauplii], for freshwater species
-HI grade [small nauplii], EG
[large nauplii]

Golden West Artemia
411 East 100 South
Salt Lake City, UT 84111
Tel. (801) 975-1222
Fax. (801) 975-1444

San Francisco Bay Brand
8239 Enterprise Drive
Newark, CA 94560
Tel. (510) 792-7200
Fax. (510) 792-5360
(Great Salt Lake,
San Francisco Bay)

Western Brine Shrimp
957 West South Temple
Salt Lake City, UT 84104
Tel. (801) 364-3642
Fax. (801) 534-0211
(Great Salt Lake)

¹ List from David A. Bengtson, University of Rhode Island, Narragansett, RI.

² The geographic sources from which the vendors obtain the brine shrimp cysts are shown in parentheses.

SECTION 6

TEST ORGANISMS

6.1 TEST SPECIES

6.1.1 The species used in characterizing the chronic toxicity of effluents and/or receiving waters will depend on the requirements of the regulatory authority and the objectives of the test. It is essential that good quality test organisms be readily available throughout the year from inhouse or commercial sources to meet NPDES monitoring requirements. The organisms used in toxicity tests must be identified to species. If there is any doubt as to the identity of the test organisms, representative specimens should be sent to a taxonomic expert to confirm the identification.

6.1.2 Toxicity test conditions and culture methods for the species listed in Subsection 6.1.3 are provided in this manual (also, see USEPA, 1993a).

6.1.3 The organisms used in the short-term tests described in this manual are the sheepshead minnow, *Cyprinodon variegatus*; the inland silverside, *Menidia beryllina*; the mysid, *Mysidopsis bahia*; the sea urchin, *Arbacia punctulata*; and the red macroalga, *Champia parvula*.

6.1.4 Some states have developed culturing and testing methods for indigenous species that may be as sensitive or more sensitive, than the species recommended in Subsection 6.1.3. However, USEPA allows the use of indigenous species only where state regulations require their use or prohibit importation of the species in Section 6, Facilities, Equipment, and Supplies, Subsection 6.1.3. Where state regulations prohibit importation of non-native fishes or use of the recommended test species, permission must be requested from the appropriate state agency prior to their use.

6.1.5 Where states have developed culturing and testing methods for indigenous species other than those recommended in this manual, data comparing the sensitivity of the substitute species and one or more of the recommended species must be obtained in side-by-side toxicity tests with reference toxicants and/or effluents, to ensure that the species selected are at least as sensitive as the recommended species. These data must be submitted to the permitting authority (State or Region) if required. USEPA acknowledges that reference toxicants prepared from pure chemicals may not always be representative of effluents. However, because of the observed and/or potential variability in the quality and toxicity of effluents, it is not possible to specify a representative effluent.

6.1.6 Guidance for the selection of test organisms where the salinity of the effluent and/or receiving water requires special consideration is provided in the Technical Support Document for Water Quality-based Toxics Control (USEPA, 1991a).

1. Where the salinity of the receiving water is < 1‰, freshwater organisms are used regardless of the salinity of the effluent.

2. Where the salinity of the receiving water is $\geq 1\%$, the choice of organisms depends on state water quality standards and/or permit requirements.

6.2 SOURCES OF TEST ORGANISMS

6.2.1 The test organisms recommended in this manual can be cultured in the laboratory using culturing and handling methods for each organism described in the respective test method sections. Also, see USEPA (1993a).

6.2.2 Inhouse cultures should be established wherever it is cost effective. If inhouse cultures cannot be maintained or it is not cost effective, test organisms should be purchased from experienced commercial suppliers (see USEPA, 1993c).

6.2.3 Sheepshead minnows, inland silversides, mysids, and sea urchins may be purchased from commercial suppliers. However, some of these organisms (e.g., adult sheepshead minnows or adult inland silversides) may not always be available from commercial suppliers and may have to be collected in the field and brought back to the laboratory for spawning to obtain eggs and larvae.

6.2.4 If, because of their source, there is any uncertainty concerning the identity of the organisms, it is advisable to have them examined by a taxonomic specialist to confirm their identification. For detailed guidance on identification, see the individual toxicity test methods.

6.2.5 FERAL (NATURAL OCCURRING, WILD CAUGHT) ORGANISMS

6.2.5.1 The use of test organisms taken from the receiving water has strong appeal, and would seem to be the logical approach. However, it is generally impractical and not recommended for the following reasons:

1. Sensitive organisms may not be present in the receiving water because of previous exposure to the effluent or other pollutants.
2. It is often difficult to collect organisms of the required age and quality from the receiving water.
3. Most states require collection permits, which may be difficult to obtain. Therefore, it is usually more cost effective to culture the organisms in the laboratory or obtain them from private, state, or Federal sources. Fish such as sheepshead minnows and silversides, and invertebrates such as mysids, are easily reared in the laboratory or purchased.
4. The required QA/QC records, such as the single-laboratory precision data, would not be available.
5. Since it is mandatory that the identity of test organisms is known to the species level, it would be necessary to examine each organism caught in the wild to confirm its identity, which would usually be impractical or, at the least, very stressful to the organisms.
6. Test organisms obtained from the wild must be observed in the laboratory for a minimum of one week prior to use, to ensure that they are free of signs of parasitic or bacterial infections and other adverse

effects. Fish captured by electroshocking must not be used in toxicity testing.

6.2.5.2 Guidelines for collection of natural occurring organisms are provided in USEPA (1973); USEPA (1990a); and USEPA (1993c).

6.2.6 Regardless of their source, test organisms should be carefully observed to ensure that they are free of signs of stress and disease, and in good physical condition. Some species of test organisms, such as trout, can be obtained from stocks certified as "disease-free."

6.3 LIFE STAGE

6.3.1 Young organisms are often more sensitive to toxicants than are adults. For this reason, the use of early life stages, such as juvenile mysids and larval fish, is required for all tests. There may be special cases, however, where the limited availability of organisms will require some deviation from the recommended life stage. In a given test, all organisms should be approximately the same age and should be taken from the same source. Since age may affect the results of the tests, it would enhance the value and comparability of the data if the same species in the same life stages were used throughout a monitoring program at a given facility.

6.4 LABORATORY CULTURING

6.4.1 Instructions for culturing and/or holding the recommended test organisms are included in specified test methods (also, see USEPA, 1993a).

6.5 HOLDING AND HANDLING TEST ORGANISMS

6.5.1 Test organisms should not be subjected to changes of more than 3°C in water temperature or 3‰ in salinity in any 12 h period.

6.5.2 Organisms should be handled as little as possible. When handling is necessary, it should be done as gently, carefully, and quickly as possible to minimize stress. Organisms that are dropped or touch dry surfaces or are injured during handling must be discarded. Dipnets are best for handling larger organisms. These nets are commercially available or can be made from small-mesh nylon netting, silk bolting cloth, plankton netting, or similar material. Wide-bore, smooth glass tubes (4 to 8 mm ID) with rubber bulbs or pipettors (such as a PROPIPETTE® or other pipettor) should be used for transferring smaller organisms such as mysids, and larval fish.

6.5.3 Holding tanks for fish are supplied with a good quality water (see Section 5, Facilities, Equipment, and Supplies) with a flow-through rate of at least two tank-volumes per day. Otherwise, use a recirculation system where the water flows through an activated carbon or undergravel filter to remove dissolved metabolites. Culture water can also be piped through high intensity ultraviolet light sources for disinfection, and to photo-degrade dissolved organics.

6.5.4 Crowding should be avoided because it will stress the organisms and lower the DO concentrations to unacceptable levels. The DO must be maintained at a minimum of 4.0 mg/L. The solubility of oxygen depends on temperature, salinity, and altitude. Aerate gently if necessary.

6.5.5 The organisms should be observed carefully each day for signs of disease, stress, physical damage, or mortality. Dead and abnormal organisms should be removed as soon as observed. It is not uncommon for some fish mortality (5-10%) to occur during the first 48 h in a holding tank because of individuals that refuse to feed on artificial food and die of starvation. Organisms in the holding tanks should generally be fed as in the cultures (see culturing methods in the respective methods).

6.5.6 Fish should be fed as much as they will eat at least once a day with live brine shrimp nauplii, *Artemia*, or frozen adult brine shrimp or dry food (frozen food should be completely thawed before use). Adult brine shrimp can be supplemented with commercially prepared food such as TETRAMIN® or BIORIL® flake food, or equivalent. Excess food and fecal material should be removed from the bottom of the tanks at least twice a week by siphoning.

6.5.7 Fish should be observed carefully each day for signs of disease, stress, physical damage, and mortality. Dead and abnormal specimens should be removed as soon as observed. It is not uncommon to have some fish (5-10%) mortality during the first 48 h in a holding tank because of individuals that refuse to feed on artificial food and die of starvation. Fish in the holding tanks should generally be fed as in the cultures (see culturing methods in the respective methods).

6.5.8 A daily record of feeding, behavioral observations, and mortality should be maintained.

6.6 TRANSPORTATION TO THE TEST SITE

6.6.1 Organisms are transported from the base or supply laboratory to a remote test site in culture water or standard dilution water in plastic bags or large-mouth screw-cap (500 mL) plastic bottles in styrofoam coolers. Adequate DO is maintained by replacing the air above the water in the bags with oxygen from a compressed gas cylinder, and sealing the bags. Another method commonly used to maintain sufficient DO during shipment is to aerate with an airstone which is supplied from a portable pump. The DO concentration must not fall below 4.0 mg/L.

6.6.2 Upon arrival at the test site, organisms are transferred to receiving water if receiving water is to be used as the test dilution water. All but a small volume of the holding water (approximately 5%) is removed by siphoning, and replaced slowly over a 10 to 15 minute period with dilution water. If receiving water is used as dilution water, caution must be exercised in exposing the test organisms to it, because of the possibility that it might be toxic. For this reason, it is recommended that only approximately 10% of the test organisms be exposed initially to the dilution water. If this group does not show excessive mortality or obvious signs of stress in a few hours, the remainder of the test organisms are transferred to the dilution water.

6.6.3 A group of organisms must not be used for a test if they appear to be unhealthy, discolored, or otherwise stressed, or if mortality appears to exceed 10% preceding the test. If the organisms fail to meet these criteria, the entire group must be discarded and a new group obtained. The mortality may be due to the presence of toxicity, if receiving water is used as dilution water, rather than a diseased condition of the test organisms. If the acclimation process is repeated with a new group of test organisms and excessive mortality occurs, it is recommended that an alternative source of dilution water be used.

6.6.4 The marine organisms can be used at all concentrations of effluent by adjusting the salinity of the effluent to salinities specified for the appropriate species test condition or to the salinity approximating that of the receiving water, by adding sufficient dry ocean salts, such as FORTY FATHOMS®, or equivalent, GP2, or hypersaline brine.

6.6.5 Saline dilution water can be prepared with deionized water or a freshwater such as well water or a suitable surface water. If dry ocean salts are used, care must be taken to ensure that the added salts are completely dissolved and the solution is aerated 24 h before the test organisms are placed in the solutions. The test organisms should be acclimated in synthetic saline water prepared with the dry salts. **Caution:** addition of dry ocean salts to dilution water may result in an increase in pH. (The pH of estuarine and coastal saline waters is normally 7.5-8.3).

6.6.6 All effluent concentrations and the control(s) used in a test should have the same salinity. The change in salinity upon acclimation at the desired test dilution should not exceed 6%. The required salinities for culturing and toxicity tests with estuarine and marine species are listed in the test method sections.

6.7 TEST ORGANISM DISPOSAL

6.7.1 When the toxicity test(s) is concluded, all test organisms (including controls) should be humanely destroyed and disposed of in an appropriate manner.

SECTION 7
DILUTION WATER

7.1 TYPES OF DILUTION WATER

7.1.1 The type of dilution water used in effluent toxicity tests will depend largely on the objectives of the study.

7.1.1.1 If the objective of the test is to estimate the chronic toxicity of the effluent, which is a primary objective of NPDES permit-related toxicity testing, a synthetic (standard) dilution water is used. If the test organisms have been cultured in water which is different from the test dilution water, a second set of controls, using culture water, should be included in the test.

7.1.1.2 If the objective of the test is to estimate the chronic toxicity of the effluent in uncontaminated receiving water, the test may be conducted using dilution water consisting of a single grab sample of receiving water (if non-toxic), collected outside the influence of the outfall, or with other uncontaminated natural water (surface water) or standard dilution water having approximately the same salinity as the receiving water. Seasonal variations in the quality of receiving waters may affect effluent toxicity. Therefore, the salinity of saline receiving water samples should be determined before each use. If the test organisms have been cultured in water which is different from the test dilution water, a second set of controls, using culture water, should be included in the test.

7.1.1.3 If the objective of the test is to determine the additive or mitigating effects of the discharge on already contaminated receiving water, the test is performed using dilution water consisting of receiving water collected outside the influence of the outfall. A second set of controls, using culture water, should be included in the test.

7.2 STANDARD, SYNTHETIC DILUTION WATER

7.2.1 Standard, synthetic, dilution water is prepared with deionized water and reagent grade chemicals (GP2) or commercial sea salts (FORTY FATHOMS®, HW MARINEMIX®) (Table 3). The source water for the deionizer can be ground water or tap water.

7.2.2 DEIONIZED WATER USED TO PREPARE STANDARD, SYNTHETIC, DILUTION WATER

7.2.2.1 Deionized water is obtained from a MILLIPORE MILLI-Q®, MILLIPORE® QPAK™₂ or equivalent system. It is advisable to provide a preconditioned (deionized) feed water by using a Culligan®, Continental®, or equivalent system in front of the MILLI-Q® System to extend the life of the MILLI-Q® cartridges (see Section 5, Facilities, Equipment, and Supplies).

7.2.2.2 The recommended order of the cartridges in a four-cartridge deionizer (i.e., MILLI-Q® System or equivalent) is: (1) ion exchange, (2) ion exchange, (3) carbon, and (4) organic cleanup (such as ORGANEX-Q®, or equivalent),

followed by a final bacteria filter. The QPAK™₂ water system is a sealed system which does not allow for the rearranging of the cartridges. However, the final cartridge is an ORGANEX-Q® filter, followed by a final bacteria filter. Commercial laboratories using this system have not experienced any difficulty in using the water for culturing or testing. Reference to the MILLI-Q® systems throughout the remainder of the manual includes all MILLIPORE® or equivalent systems.

7.2.3 STANDARD, SYNTHETIC SEAWATER

7.2.3.1 To prepare 20 L of a standard, synthetic, reconstituted seawater (modified GP2), using reagent grade chemicals (Table 3), with a salinity of 31‰, follow the instructions below. Other salinities can be prepared by making the appropriate dilutions. Larger or smaller volumes of modified GP2 can be prepared by using proportionately larger or smaller amounts of salts and dilution water.

1. Place 20 L of MILLI-Q® or equivalent deionized water in a properly cleaned plastic carboy.
2. Weigh reagent grade salts listed in Table 3 and add, one at a time, to the deionized water. Stir well after adding each salt.
3. Aerate the final solution at a rate of 1 L/h for 24 h.
4. Check the pH and salinity.

7.2.3.2 Synthetic seawater can also be prepared by adding commercial sea salts, such as FORTY FATHOMS®, HW MARINEMIX®, or equivalent, to deionized water. For example, thirty-one parts per thousand (31‰) FORTY FATHOMS® can be prepared by dissolving 31 g of sea salts per liter of deionized water. The salinity of the resulting solutions should be checked with a refractometer.

7.2.4 Artificial seawater is to be used only if specified in the method. EMSL-Cincinnati has found FORTY FATHOMS® artificial sea salts (Marine Enterprises, Inc., 8755 Mylander Lane, Baltimore, MD 21204, 301-321-1189) suitable for maintaining and spawning the sheepshead minnow, *Cyprinodon variegatus*, and for its use in the sheepshead minnow larval survival and growth test, suitable for maintaining and spawning the inland silverside, *Menidia beryllina*, and for its use in the inland silverside larval survival and growth test, suitable for culturing and maintaining mysid shrimp, *Mysidopsis bahia*, and its use in the mysid shrimp survival, growth, and fecundity test, and suitable for maintaining sea urchins, *Arbacia punctulata*, and for its use in the sea urchin fertilization test. The USEPA Region 6 Houston Laboratory has successfully used HW MARINEMIX® (Hawaiian Marine Imports Inc., P.O. Box 218687, Houston, TX 77218, 713-492-7864) sea salts to maintain and spawn sheepshead minnows, and perform the larval survival and growth test and the embryo-larval survival and teratogenicity test. Also, HW MARINEMIX® sea salts has been used successfully to culture and maintain the mysid brood stock and perform the mysid survival, growth, fecundity test. An artificial seawater formulation, GP2 (Spotte et al., 1984), Table 3, has been used by the Environmental Research Laboratory-Narragansett, RI for all but the embryo-larval survival and teratogenicity test. The suitability of GP2 as a medium for culturing organisms has not been determined.

TABLE 3. PREPARATION OF GP2 ARTIFICIAL SEAWATER USING REAGENT GRADE CHEMICALS^{1,2,3}

Compound	Concentration (g/L)	Amount (g) Required for 20 L
NaCl	21.03	420.6
Na ₂ SO ₄	3.52	70.4
KCl	0.61	12.2
KBr	0.088	1.76
Na ₂ B ₄ O ₇ · 10 H ₂ O	0.034	0.68
MgCl ₂ · 6 H ₂ O	9.50	190.0
CaCl ₂ · 2 H ₂ O	1.32	26.4
SrCl ₂ · 6 H ₂ O	0.02	0.400
NaHCO ₃	0.17	3.40

¹ Modified GP2 from Spotte et al. (1984).

² The constituent salts and concentrations were taken from USEPA (1993a). The salinity is 30.89 g/L.

³ GP2 can be diluted with deionized (DI) water to the desired test salinity.

7.3 USE OF RECEIVING WATER AS DILUTION WATER

7.3.1 If the objectives of the test require the use of uncontaminated receiving water as dilution water, and the receiving water is uncontaminated, it may be possible to collect a sample of the receiving water close to the outfall, but should be away from or beyond the influence of the effluent. However, if the receiving water is contaminated, it may be necessary to collect the sample in an area "remote" from the discharge site, matching as closely as possible the physical and chemical characteristics of the receiving water near the outfall.

7.3.2 The sample should be collected immediately prior to the test, but never more than 96 h before the test begins. Except where it is used within 24 h, or in the case where large volumes are required for flow through tests, the sample should be chilled to 4°C during or immediately following collection, and maintained at that temperature prior to use in the test.

7.3.3 The investigator should collect uncontaminated water having a salinity as near as possible to the salinity of the receiving water at the discharge site. Water should be collected at slack high tide, or within one hour after high tide. If there is reason to suspect contamination of the water in the estuary, it is advisable to collect uncontaminated water from an adjacent estuary. At times it may be necessary to collect water at a location closer to the open sea, where the salinity is relatively high. In such cases, deionized water or uncontaminated freshwater is added to the saline water to dilute it to the required test salinity. Where necessary, the salinity of a surface water can be increased by the addition of artificial sea salts, such as FORTY FATHOMS®, HW MARINEMIX®, or equivalent, GP2, a natural seawater of higher salinity, or hypersaline brine. Instructions for the preparation of hypersaline brine by concentrating natural seawater are provided below.

7.3.4 Receiving water containing debris or indigenous organisms, that may be confused with or attack the test organisms, should be filtered through a sieve having 60 µm mesh openings prior to use.

7.3.5 HYPERSALINE BRINE

7.3.5.1 Hypersaline brine (HSB) has several advantages that make it desirable for use in toxicity testing. It can be made from any high quality, filtered seawater by evaporation, and can be added to deionized water to prepare dilution water, or to effluents or surface waters to increase their salinity.

7.3.5.2 The ideal container for making HSB from natural seawater is one that (1) has a high surface to volume ratio, (2) is made of a noncorrosive material, and (3) is easily cleaned (fiberglass containers are ideal). Special care should be used to prevent any toxic materials from coming in contact with the seawater being used to generate the brine. If a heater is immersed directly into the seawater, ensure that the heater materials do not corrode or leach any substances that would contaminate the brine. One successful method used is a thermostatically controlled heat exchanger made from fiberglass. If aeration is used, use only oil-free air compressors to prevent contamination.

7.3.5.3 Before adding seawater to the brine generator, thoroughly clean the generator, aeration supply tube, heater, and any other materials that will be in direct contact with the brine. A good quality biodegradable detergent should be used, followed by several thorough deionized water rinses. High quality (and preferably high salinity) seawater should be filtered to at least 10 µm before placing into the brine generator. Water should be collected on an incoming tide to minimize the possibility of contamination.

7.3.5.4 The temperature of the seawater is increased slowly to 40°C. The water should be aerated to prevent temperature stratification and to increase

water evaporation. The brine should be checked daily (depending on the volume being generated) to ensure that the salinity does not exceed 100‰ and that the temperature does not exceed 40°C. Additional seawater may be added to the brine to obtain the volume of brine required.

7.3.5.5 After the required salinity is attained, the HSB should be filtered a second time through a 1- μ m filter and poured directly into portable containers (20-L CUBITAINERS® or polycarbonate water cooler jugs are suitable). The containers should be capped and labelled with the date the brine was generated and its salinity. Containers of HSB should be stored in the dark and maintained under room temperature until used.

7.3.5.6 If a source of HSB is available, test solutions can be made by following the directions below. Thoroughly mix together the deionized water and brine before mixing in the effluent.

7.3.5.7 Divide the salinity of the HSB by the expected test salinity to determine the proportion of deionized water to brine. For example, if the salinity of the brine is 100‰ and the test is to be conducted at 25‰, $100\% \div 25\% = 4.0$. The proportion of brine is 1 part in 4 (one part brine to three parts deionized water).

7.3.5.8 To make 1 L of seawater at 25‰ salinity from a hypersaline brine of 100‰, 250 mL of brine and 750 mL of deionized water are required.

7.4 USE OF TAP WATER AS DILUTION WATER

7.4.1 The use of tap water in the reconstituting of synthetic (artificial) seawater as dilution water is discouraged unless it is dechlorinated and fully treated. Tap water can be dechlorinated by deionization, carbon filtration, or the use of sodium thiosulfate. Use of 3.6 mg/L (anhydrous) sodium thiosulfate will reduce 1.0 mg chlorine/L (APHA, 1992). Following dechlorination, total residual chlorine should not exceed 0.01 mg/L. Because of the possible toxicity of thiosulfate to test organisms, a control lacking thiosulfate should be included in toxicity tests utilizing thiosulfate-dechlorinated water.

7.4.2 To be adequate for general laboratory use following dechlorination, the tap water is passed through a deionizer and carbon filter to remove toxic metals and organics, and to control hardness and alkalinity.

7.5 DILUTION WATER HOLDING

7.5.1 A given batch of dilution water should not be used for more than 14 days following preparation because of the possible build up of bacterial, fungal, or algal slime growth and the problems associated with it. The container should be kept covered and the contents should be protected from light.

SECTION 8

EFFLUENT AND RECEIVING WATER SAMPLING, SAMPLE HANDLING, AND SAMPLE PREPARATION FOR TOXICITY TESTS

8.1 EFFLUENT SAMPLING

8.1.1 The effluent sampling point should be the same as that specified in the NPDES discharge permit (USEPA, 1988b). Conditions for exception would be: (1) better access to a sampling point between the final treatment and the discharge outfall; (2) if the processed waste is chlorinated prior to discharge, it may also be desirable to take samples prior to contact with the chlorine to determine toxicity of the unchlorinated effluent; or (3) in the event there is a desire to evaluate the toxicity of the influent to municipal waste treatment plants or separate wastewater streams in industrial facilities prior to their being combined with other wastewater streams or non-contact cooling water, additional sampling points may be chosen.

8.1.2 The decision on whether to collect grab or composite samples is based on the objectives of the test and an understanding of the short and long-term operations and schedules of the discharger. If the effluent quality varies considerably with time, which can occur where holding times are short, grab samples may seem preferable because of the ease of collection and the potential of observing peaks (spikes) in toxicity. However, the sampling duration of a grab sample is so short that full characterization of an effluent over a 24-h period would require a prohibitively large number of separate samples and tests. Collection of a 24-h composite sample, however, may dilute toxicity spikes, and average the quality of the effluent over the sampling period. Sampling recommendations are provided below (also see USEPA, 1993a).

8.1.3 Aeration during collection and transfer of effluents should be minimized to reduce the loss of volatile chemicals.

8.1.4 Details of date, time, location, duration, and procedures used for effluent sample and dilution water collection should be recorded.

8.2 EFFLUENT SAMPLE TYPES

8.2.1 The advantages and disadvantages of effluent grab and composite samples are listed below:

8.2.1.1 GRAB SAMPLES

Advantages:

1. Easy to collect; require a minimum of equipment and on-site time.
2. Provide a measure of instantaneous toxicity. Toxicity spikes are not masked by dilution.

Disadvantages:

1. Samples are collected over a very short period of time and on a relatively infrequent basis. The chances of detecting a spike in toxicity would depend on the frequency of sampling, and the probability of missing spikes is high.

8.2.1.2 COMPOSITE SAMPLES:

Advantages:

1. A single effluent sample is collected over a 24-h period.
2. The sample is collected over a much longer period of time than grab samples and contains all toxicity spikes.

Disadvantages:

1. Sampling equipment is more sophisticated and expensive, and must be placed on-site for at least 24 h.
2. Toxicity spikes may not be detected because they are masked by dilution with less toxic wastes.

8.3 EFFLUENT SAMPLING RECOMMENDATIONS

8.3.1 When tests are conducted on-site, test solutions can be renewed daily with freshly collected samples.

8.3.2 When tests are conducted off-site, a minimum of three samples are collected. If these samples are collected on Test Days 1, 3, and 5, the first sample would be used for test initiation, and for test solution renewal on Day 2. The second sample would be used for test solution renewal on Days 3 and 4. The third sample would be used for test solution renewal on Days 5, 6, and 7.

8.3.3 Sufficient sample must be collected to perform the required toxicity and chemical tests. A 4-L (1-gal) CUBITAINER® will provide sufficient sample volume for most tests.

8.3.4 THE FOLLOWING EFFLUENT SAMPLING METHODS ARE RECOMMENDED:

8.3.4.1 Continuous Discharges

1. If the facility discharge is continuous, but the calculated retention time of the continuously discharged effluent is less than 14 days and the variability of the effluent toxicity is unknown, at a minimum, four grab samples or four composite samples are collected over a 24-h period. For example, a grab sample is taken every 6 h (total of four samples) and each sample is used for a separate toxicity test, or four successive 6-h composite samples are taken and each is used in a separate test.
2. If the calculated retention time of a continuously discharged effluent is greater than 14 days, or if it can be demonstrated that the

wastewater does not vary more than 10% in toxicity over a 24-h period, regardless of retention time, a single grab sample is collected for a single toxicity test.

3. The retention time of the effluent in the wastewater treatment facility may be estimated from calculations based on the volume of the retention basin and rate of wastewater inflow. However, the calculated retention time may be much greater than the actual time because of short-circuiting in the holding basin. Where short-circuiting is suspected, or sedimentation may have reduced holding basin capacity, a more accurate estimate of the retention time can be obtained by carrying out a dye study.

8.3.4.2 Intermittent Discharges

8.3.4.2.1 If the facility discharge is intermittent, a grab sample is collected midway during each discharge period. Examples of intermittent discharges are:

1. When the effluent is continuously discharged during a single 8-h work shift (one sample is collected), or two successive 8-h work shifts (two samples are collected).
2. When the facility retains the wastewater during an 8-h work shift, and then treats and releases the wastewater as a batch discharge (one sample is collected).
3. When the facility discharges wastewater to an estuary only during an outgoing tide, usually during the 4 h following slack high tide (one sample is collected).
4. At the end of a shift, clean up activities may result in the discharge of a slug of toxic waste (one sample is collected).

8.4 RECEIVING WATER SAMPLING

8.4.1 Logistical problems and difficulty in securing sampling equipment generally preclude the collection of composite receiving water samples for toxicity tests. Therefore, based on the requirements of the test, a single grab sample or daily grab samples of receiving water is collected for use in the test.

8.4.2 The sampling point is determined by the objectives of the test. At estuarine and marine sites, samples should be collected at mid-depth.

8.4.3 To determine the extent of the zone of toxicity in the receiving water at estuarine and marine effluent sites, receiving water samples are collected at several distances away from the discharge. The time required for the effluent-receiving-water mixture to travel to sampling points away from the effluent, and the rate and degree of mixing, may be difficult to ascertain. Therefore, it may not be possible to correlate receiving water toxicity with effluent toxicity at the discharge point unless a dye study is performed. The toxicity of receiving water samples from five stations in the discharge plume can be evaluated using the same number of test vessels and test organisms as used in one effluent toxicity test with five effluent dilutions.

8.5 EFFLUENT AND RECEIVING WATER SAMPLE HANDLING, PRESERVATION, AND SHIPPING

8.5.1 Unless the samples are used in an on-site toxicity test the day of collection, it is recommended that they be held at 4°C until used to inhibit microbial degradation, chemical transformations, and loss of highly volatile toxic substances.

8.5.2 Composite samples should be chilled as they are collected. Grab samples should be chilled immediately following collection.

8.5.3 If the effluent has been chlorinated, total residual chlorine must be measured immediately following sample collection.

8.5.4 Sample holding time begins when the last grab sample in a series is taken (i.e., when a series of four grab samples are taken over a 24-h period), or when a 24-h composite sampling period is completed. If the data from the samples are to be acceptable for use in the NPDES Program, the lapsed time (holding time) from sample collection to first use of the sample in test initiation must not exceed 36 h. EPA believes that 36 h is adequate time to deliver the sample to the laboratories performing the test in most cases. In the isolated cases, where the permittee can document that this delivery time cannot be met, the permitting authority can allow an option for on-site testing or a variance for an extension of shipped sample holding time. The request for a variance in sample holding time, directed to the USEPA Regional Administrator under 40 CFR 136.3(e), must include supportive data which show that the toxicity of the effluent sample is not reduced (e.g., because of volatilization and/or sorption of toxics on the sample container surfaces) by extending the holding time beyond more than 36 h. However, in no case should more than 72 h elapse between collection and first use of the sample. In static-renewal tests, the original sample may also be used to prepare test solutions for renewal at 24 h and 48 h after test initiation, if stored at 4°C, with minimum head space, as described in Paragraph 8.5. Guidance for determining the persistence of the sample is provided in Subsection 8.7.

8.5.5 To minimize the loss of toxicity due to volatilization of toxic constituents, all sample containers should be "completely" filled, leaving no air space between the contents and the lid.

8.5.6 SAMPLES USED IN ON-SITE TESTS

8.5.6.1 Samples collected for on-site tests should be used within 24 h.

8.5.7 SAMPLES SHIPPED TO OFF SITE FACILITIES

8.5.7.1 Samples collected for off site toxicity testing are to be chilled to 4°C during or immediately after collection, and shipped iced to the performing laboratory. Sufficient ice should be placed with the sample in the shipping container to ensure that ice will still be present when the sample arrives at the laboratory and is unpacked. Insulating material must not be placed between the ice and the sample in the shipping container.

8.5.7.2 Samples may be shipped in one or more 4-L (1-gal) CUBITAINERS® or new plastic "milk" jugs. All sample containers should be rinsed with source water before being filled with sample. After use with receiving water or effluents, CUBITAINERS® and plastic jugs are punctured to prevent reuse.

8.5.7.3 Several sample shipping options are available, including Express Mail, air express, bus, and courier service. Express Mail is delivered seven days a week. Saturday and Sunday shipping and receiving schedules of private carriers vary with the carrier.

8.6 SAMPLE RECEIVING

8.6.1 Upon arrival at the laboratory, samples are logged in and the temperature is measured and recorded. If the samples are not immediately prepared for testing, they are stored at 4°C until used.

8.6.2 Every effort must be made to initiate the test with an effluent sample on the day of arrival in the laboratory, and the sample holding time should not exceed 36 h unless a variance has been granted by the NPDES permitting authority.

8.7 PERSISTENCE OF EFFLUENT TOXICITY DURING SAMPLE SHIPMENT AND HOLDING

8.7.1 The persistence of the toxicity of an effluent prior to its use in a toxicity test is of interest in assessing the validity of toxicity test data, and in determining the possible effects of allowing an extension of the holding time. Where a variance in holding time (> 36 h, but ≤ 72 h) is requested by a permittee (See subsection 8.5.4), information on the effects of the extension in holding time on the toxicity of the samples must be obtained by comparing the results of multi-concentration chronic toxicity tests performed on effluent samples held 36 h with toxicity test results using the same samples after they were held for the requested, longer period. The portion of the sample set aside for the second test must be held under the same conditions as during shipment and holding.

8.8 PREPARATION OF EFFLUENT AND RECEIVING WATER SAMPLES FOR TOXICITY TESTS

8.8.1 Adjust the sample salinity to the level appropriate for objectives of the study using hypersaline brine or artificial sea salts.

8.8.2 When aliquots are removed from the sample container, the head space above the remaining sample should be held to a minimum. Air which enters a container upon removal of sample should be expelled by compressing the container before reclosing, if possible (i.e., where a CUBITAINER® used), or by using an appropriate discharge valve (spigot).

8.8.3 It may be necessary to first coarse-filter samples through a NYLON® sieve having 2 to 4 mm mesh openings to remove debris and/or break up large floating or suspended solids. If samples contain indigenous organisms that may attack or be confused with the test organisms, the samples must be filtered through a sieve with 60 μm mesh openings. Since filtering may increase the dissolved oxygen (DO) in an effluent, the DO should be determined prior to filtering. Low dissolved

oxygen concentrations will indicate a potential problem in performing the test. **Caution:** filtration may remove some toxicity.

8.8.4 If the samples must be warmed to bring them to the prescribed test temperature, supersaturation of the dissolved oxygen and nitrogen may become a problem. To avoid this problem, the effluent and dilution water are checked with a DO probe after reaching test temperature and, if the DO is greater than 100% saturation or lower than 4.0 mg/L, based on temperature and salinity, the solutions are aerated moderately (approximately 500 mL/min) for a few minutes, using an airstone, until the DO is lowered to 100% saturation (Table 4) or until the DO is within the prescribed range (≥ 4.0 mg/L). **Caution:** avoid excessive aeration.

8.8.4.1 Aeration during the test may alter the results and should be used only as a last resort to maintain the required DO. Aeration can reduce the apparent toxicity of the test solutions by stripping them of highly volatile toxic substances, or increase their toxicity by altering the pH. However, the DO in the test solution must not be permitted to fall below 4.0 mg/L.

8.8.4.2 In static tests (non-renewal or renewal) low DOs may commonly occur in the higher concentrations of wastewater. Aeration is accomplished by bubbling air through a pipet at the rate of 100 bubbles/min. If aeration is necessary, all test solutions must be aerated. It is advisable to monitor the DO closely during the first few hours of the test. Samples with a potential DO problem generally show a downward trend in DO within 4 to 8 h after the test is started. Unless aeration is initiated during the first 8 h of the test, the DO may be exhausted during an unattended period, thereby invalidating the test.

8.8.5 At a minimum, pH, conductivity or salinity, and total residual chlorine are measured in the undiluted effluent or receiving water, and pH and conductivity are measured in the dilution water.

8.8.5.1 It is recommended that total alkalinity and total hardness also be measured in the undiluted effluent test water and the dilution water.

8.8.6 Total ammonia is measured in effluent and receiving water samples where toxicity may be contributed by unionized ammonia (i.e., where total ammonia ≥ 5 mg/L). The concentration (mg/L) of unionized (free) ammonia in a sample is a function of temperature and pH, and is calculated using the percentage value obtained from Table 5, under the appropriate pH and temperature, and multiplying it by the concentration (mg/L) of total ammonia in the sample.

8.8.7 Effluents and receiving waters can be dechlorinated using 6.7 mg/L anhydrous sodium thiosulfate to reduce 1 mg/L chlorine (APHA, 1992). Note that the amount of thiosulfate required to dechlorinate effluents is greater than the amount needed to dechlorinate tap water, (see Section 7, Dilution Water). Since thiosulfate may contribute to sample toxicity, a thiosulfate control should be used in the test in addition to the normal dilution water control.

8.8.8 The DO concentration in the samples should be near saturation prior to use. Aeration will bring the DO and other gases into equilibrium with air, minimize oxygen demand, and stabilize the pH. However, aeration during

TABLE 4. OXYGEN SOLUBILITY (MG/L) IN WATER AT EQUILIBRIUM WITH AIR AT 760 MM HG (AFTER Richards and Corwin, 1956)

TEMP (C°)	SALINITY (‰)									
	0	5	10	15	20	25	30	35	40	43
0	14.2	13.8	13.4	12.9	12.5	12.1	11.7	11.2	10.8	10.6
1	13.8	13.4	13.0	12.6	12.2	11.8	11.4	11.0	10.6	10.3
2	13.4	13.0	12.6	12.2	11.9	11.5	11.1	10.7	10.3	10.0
3	13.1	12.7	12.3	11.9	11.6	11.2	10.8	10.4	10.0	9.8
4	12.7	12.3	12.0	11.6	11.3	10.9	10.5	10.1	9.8	9.5
5	12.4	12.0	11.7	11.3	11.0	10.6	10.2	9.8	9.5	9.3
6	12.1	11.7	11.4	11.0	10.7	10.3	10.0	9.6	9.3	9.1
8	11.5	11.2	10.8	10.5	10.2	9.8	9.5	9.2	8.9	8.7
10	10.9	10.7	10.3	10.0	9.7	9.4	9.1	8.8	8.5	8.3
12	10.5	10.2	9.9	9.6	9.3	9.0	8.7	8.4	8.1	7.9
14	10.0	9.7	9.5	9.2	8.9	8.6	8.3	8.1	7.8	7.6
16	9.6	9.3	9.1	8.8	8.5	8.3	8.0	7.7	7.5	7.3
18	9.2	9.0	8.7	8.5	8.2	8.0	7.7	7.5	7.2	7.1
20	8.9	8.6	8.4	8.1	7.9	7.7	7.4	7.2	6.9	6.8
22	8.6	8.4	8.1	7.9	7.6	7.4	7.2	6.9	6.7	6.6
24	8.3	8.1	7.8	7.6	7.4	7.2	6.9	6.7	6.5	6.4
26	8.1	7.8	7.6	7.4	7.2	7.0	6.7	6.5	6.3	6.1
28	7.8	7.6	7.4	7.2	7.0	6.8	6.5	6.3	6.1	6.0
30	7.6	7.4	7.1	6.9	6.7	6.5	6.3	6.1	5.9	5.8
32	7.3	7.1	6.9	6.7	6.5	6.3	6.1	5.9	5.7	5.6

TABLE 5. PERCENT UNIONIZED NH₃ IN AQUEOUS AMMONIA SOLUTIONS: TEMPERATURE 15-26°C AND pH 6.0-8.9¹

pH	TEMPERATURE (°C)											
	15	16	17	18	19	20	21	22	23	24	25	26
6.0	0.0274	0.0295	0.0318	0.0343	0.0369	0.0397	0.0427	0.0459	0.0493	0.0530	0.0568	0.0610
6.1	0.0345	0.0372	0.0400	0.0431	0.0464	0.0500	0.0537	0.0578	0.0621	0.0667	0.0716	0.0768
6.2	0.0434	0.0468	0.0504	0.0543	0.0584	0.0629	0.0676	0.0727	0.0781	0.0901	0.0901	0.0966
6.3	0.0546	0.0589	0.0634	0.0683	0.0736	0.0792	0.0851	0.0915	0.0983	0.1134	0.1134	0.1216
6.4	0.0687	0.0741	0.0799	0.0860	0.0926	0.0996	0.107	0.115	0.124	0.133	0.143	0.153
6.5	0.0865	0.0933	0.1005	0.1083	0.1166	0.1254	0.135	0.145	0.156	0.167	0.180	0.193
6.6	0.109	0.117	0.127	0.136	0.147	0.158	0.170	0.182	0.196	0.210	0.226	0.242
6.7	0.137	0.148	0.159	0.171	0.185	0.199	0.214	0.230	0.247	0.265	0.284	0.305
6.8	0.172	0.186	0.200	0.216	0.232	0.250	0.269	0.289	0.310	0.333	0.358	0.384
6.9	0.217	0.234	0.252	0.271	0.292	0.314	0.338	0.363	0.390	0.419	0.450	0.482
7.0	0.273	0.294	0.317	0.342	0.368	0.396	0.425	0.457	0.491	0.527	0.566	0.607
7.1	0.343	0.370	0.399	0.430	0.462	0.497	0.535	0.575	0.617	0.663	0.711	0.762
7.2	0.432	0.466	0.502	0.540	0.581	0.625	0.672	0.722	0.776	0.833	0.893	0.958
7.3	0.543	0.586	0.631	0.679	0.731	0.786	0.845	0.908	0.975	1.05	1.12	1.20
7.4	0.683	0.736	0.793	0.854	0.918	0.988	1.061	1.140	1.224	1.31	1.41	1.51
7.5	0.858	0.925	0.996	1.07	1.15	1.24	1.33	1.43	1.54	1.65	1.77	1.89
7.6	1.08	1.16	1.25	1.35	1.45	1.56	1.67	1.80	1.93	2.07	2.21	2.37
7.7	1.35	1.46	1.57	1.69	1.82	1.95	2.10	2.25	2.41	2.59	2.77	2.97
7.8	1.70	1.83	1.97	2.12	2.28	2.44	2.62	2.82	3.02	3.24	3.46	3.71
7.9	2.13	2.29	2.46	2.65	2.85	3.06	3.28	3.52	3.77	4.04	4.32	4.62
8.0	2.66	2.87	3.08	3.31	3.56	3.82	4.10	4.39	4.70	5.03	5.38	5.75
8.1	3.33	3.58	3.85	4.14	4.44	4.76	5.10	5.46	5.85	6.25	6.68	7.14
8.2	4.16	4.47	4.80	5.15	5.52	5.92	6.34	6.78	7.25	7.75	8.27	8.82
8.3	5.18	5.56	5.97	6.40	6.86	7.34	7.85	8.39	8.96	9.56	10.2	10.9
8.4	6.43	6.90	7.40	7.93	8.48	9.07	9.69	10.3	11.0	11.7	12.5	13.3
8.5	7.97	8.54	9.14	9.78	10.45	11.16	11.90	12.7	13.5	14.4	15.2	16.2
8.6	9.83	10.5	11.2	12.0	12.8	13.6	14.5	15.5	16.4	17.4	18.5	19.5
8.7	12.07	12.9	13.8	14.7	15.6	16.6	17.6	18.7	19.8	21.0	22.2	23.4
8.8	14.7	15.7	16.7	17.8	18.9	20.0	21.2	22.5	23.7	25.1	26.4	27.8
8.9	17.9	19.0	20.2	21.4	22.7	24.0	25.3	26.7	28.2	29.6	31.1	32.6

¹ Table provided by Teresa Norberg-King, Duluth, Minnesota. Also see Emerson et al. (1975), Thurston et al. (1974), and USEPA (1985a).

collection, transfer, and preparation of samples should be minimized to reduce the loss of volatile chemicals.

8.8.9 Mortality or impairment of growth or reproduction due to pH alone may occur if the pH of the sample falls outside the range of 6.0 - 9.0. Thus, the presence of other forms of toxicity (metals and organics) in the sample may be masked by the toxic effects of low or high pH. The question about the presence of other toxicants can be answered only by performing two parallel tests, one with an adjusted pH, and one without an adjusted pH. Freshwater samples are adjusted to pH 7.0, and marine samples are adjusted to pH 8.0, by adding 1N NaOH or 1N HCl dropwise, as required, being careful to avoid overadjustment.

8.9 PRELIMINARY TOXICITY RANGE-FINDING TESTS

8.9.1 USEPA Regional and State personnel generally have observed that it is not necessary to conduct a toxicity range-finding test prior to initiating a static, chronic, definitive toxicity test. However, when preparing to perform a static test with a sample of completely unknown quality, or before initiating a flow-through test, it is advisable to conduct a preliminary toxicity range-finding test.

8.9.2 A toxicity range-finding test ordinarily consists of a down-scaled, abbreviated static acute test in which groups of five organisms are exposed to several widely-spaced sample dilutions in a logarithmic series, such as 100%, 10.0%, 1.00%, and 0.100%, and a control, for 8-24 h. Caution: if the sample must also be used for the full-scale definitive test, the 36-h limit on holding time (see Subsection 8.5.4) must not be exceeded before the definitive test is initiated.

8.9.3 It should be noted that the toxicity (LC50) of a sample observed in a range-finding test may be significantly different from the toxicity observed in the follow-up, chronic, definitive test because: (1) the definitive test is longer; and (2) the test may be performed with a sample collected at a different time, and possibly differing significantly in the level of toxicity.

8.10 MULTICONCENTRATION (DEFINITIVE) EFFLUENT TOXICITY TESTS

8.10.1 The tests recommended for use in determining discharge permit compliance in the NPDES program are multiconcentration, or definitive, tests which provide (1) a point estimate of effluent toxicity in terms of an IC25, IC50, or LC50, or (2) a no-observed-effect-concentration (NOEC) defined in terms of mortality, growth, reproduction, and/or teratogenicity and obtained by hypothesis testing. The tests may be static renewal or static non-renewal.

8.10.2 The tests consist of a control and a minimum of five effluent concentrations commonly selected to approximate a geometric series, such as 100%, 50%, 25%, 12.5%, and 6.25%, using a ≥ 0.5 dilution series.

8.10.3 These tests are also to be used in determining compliance with permit limits on the mortality of the receiving water concentration (RWC) of effluents by bracketing the RWC with effluent concentrations in the following manner: (1) 100% effluent, (2) $[RWC + 100]/2$, (3) RWC, (4) $RWC/2$, and (5) $RWC/4$. For

example, where the RWC = 50%, the effluent concentrations used in the test would be 100%, 75%, 50%, 25%, and 12.5%.

8.10.4 If acute/chronic ratios are to be determined by simultaneous acute and short-term chronic tests with a single species, using the same sample, both types of tests must use the same test conditions, i.e., pH, temperature, water hardness, salinity, etc.

8.11 RECEIVING WATER TESTS

8.11.1 Receiving water toxicity tests generally consist of 100% receiving water and a control. The total salinity of the control should be comparable to the receiving water.

8.11.2 The data from the two treatments are analyzed by hypothesis testing to determine if test organism survival in the receiving water differs significantly from the control. Four replicates and 10 organisms per replicate are required for each treatment (see Summary of Test Conditions and Test Acceptability Criteria in the specific test method).

8.11.3 In cases where the objective of the test is to estimate the degree of toxicity of the receiving water, a definitive, multiconcentration test is performed by preparing dilutions of the receiving water, using a ≥ 0.5 dilution series, with a suitable control water.

SECTION 9

CHRONIC TOXICITY TEST ENDPOINTS AND DATA ANALYSIS

9.1 ENDPOINTS

9.1.1 The objective of chronic aquatic toxicity tests with effluents and pure compounds is to estimate the highest "safe" or "no-effect concentration" of these substances. For practical reasons, the responses observed in these tests are usually limited to hatchability, gross morphological abnormalities, survival, growth, and reproduction, and the results of the tests are usually expressed in terms of the highest toxicant concentration that has no statistically significant observed effect on these responses, when compared to the controls. The terms currently used to define the endpoints employed in the rapid, chronic and sub-chronic toxicity tests have been derived from the terms previously used for full life-cycle tests. As shorter chronic tests were developed, it became common practice to apply the same terminology to the endpoints. The terms used in this manual are as follows:

9.1.1.1 Safe Concentration - The highest concentration of toxicant that will permit normal propagation of fish and other aquatic life in receiving waters. The concept of a "safe concentration" is a biological concept, whereas the "no-observed-effect concentration" (below) is a statistically defined concentration.

9.1.1.2 No-Observed-Effect-Concentration (NOEC) - The highest concentration of toxicant to which organisms are exposed in a full life-cycle or partial life-cycle (short-term) test, that causes no observable adverse effects on the test organisms (i.e., the highest concentration of toxicant in which the values for the observed responses are not statistically significantly different from the controls). This value is used, along with other factors, to determine toxicity limits in permits.

9.1.1.3 Lowest-Observed-Effect-Concentration (LOEC) - The lowest concentration of toxicant to which organisms are exposed in a life-cycle or partial life-cycle (short-term) test, which causes adverse effects on the test organisms (i.e., where the values for the observed responses are statistically significantly different from the controls).

9.1.1.4 Effective Concentration (EC) - A point estimate of the toxicant concentration that would cause an observable adverse effect on a quantal, "all or nothing," response (such as death, immobilization, or serious incapacitation) in a given percent of the test organisms, calculated by point estimation techniques. If the observable effect is death or immobility, the term, Lethal Concentration (LC), should be used (see Subsection 9.1.1.5). A certain EC or LC value might be judged from a biological standpoint to represent a threshold concentration, or lowest concentration that would cause an adverse effect on the observed response.

9.1.1.5 Lethal Concentration (LC) - The toxicant concentration that would cause death in a given percent of the test population. Identical to EC when the

observable adverse effect is death. For example, the LC50 is the concentration of toxicant that would cause death in 50% of the test population.

9.1.1.6 Inhibition Concentration (IC) - The toxicant concentration that would cause a given percent reduction in a nonquantal biological measurement for the test population. For example, the IC25 is the concentration of toxicant that would cause a 25% reduction in mean young per female or in growth for the test population, and the IC50 is the concentration of toxicant that would cause a 50% reduction in the mean population responses.

9.2 RELATIONSHIP BETWEEN ENDPOINTS DETERMINED BY HYPOTHESIS TESTING AND POINT ESTIMATION TECHNIQUES

9.2.1 If the objective of chronic aquatic toxicity tests with effluents and pure compounds is to estimate the highest "safe or no-effect concentration" of these substances, it is imperative to understand how the statistical endpoints of these tests are related to the "safe" or "no-effect" concentration. NOECs and LOECs are determined by hypothesis testing (Dunnett's Test, a t test with the Bonferroni adjustment, Steel's Many-One Rank Test, or the Wilcoxon Rank Sum Test with Bonferroni adjustment), whereas LCs, ICs, and ECs are determined by point estimation techniques (Probit Analysis, the Spearman-Kärber Method, the Trimmed Spearman-Kärber Method, the Graphical Method or Linear Interpolation Method). There are inherent differences between the use of a NOEC or LOEC derived from hypothesis testing to estimate a "safe" concentration, and the use of a LC, IC, EC, or other point estimates derived from curve fitting, interpolation, etc.

9.2.2 Most point estimates, such as the LC, IC, or EC are derived from a mathematical model that assumes a continuous dose-response relationship. By definition, any LC, IC, or EC value is an estimate of some amount of adverse effect. Thus the assessment of a "safe" concentration must be made from a biological standpoint rather than with a statistical test. In this instance, the biologist must determine some amount of adverse effect that is deemed to be "safe," in the sense that from a practical biological viewpoint it will not affect the normal propagation of fish and other aquatic life in receiving waters.

9.2.3 The use of NOECs and LOECs, on the other hand, assumes either (1) a continuous dose-response relationship, or (2) a non-continuous (threshold) model of the dose-response relationship.

9.2.3.1 In the case of a continuous dose-response relationship, it is also assumed that adverse effects that are not "statistically observable" are also not important from a biological standpoint, since they are not pronounced enough to test as statistically significant against some measure of the natural variability of the responses.

9.2.3.2 In the case of non-continuous dose-response relationships, it is assumed that there exists a true threshold, or concentration below which there is no adverse effect on aquatic life, and above which there is an adverse effect. The purpose of the statistical analysis in this case is to estimate as closely as possible where that threshold lies.

9.2.3.3 In either case, it is important to realize that the amount of adverse effect that is statistically observable (LOEC) or not observable (NOEC) is highly dependent on all aspects of the experimental design, such as the number of concentrations of toxicant, number of replicates per concentration, number of organisms per replicate, and use of randomization. Other factors that affect the sensitivity of the test include the choice of statistical analysis, the choice of an alpha level, and the amount of variability between responses at a given concentration.

9.2.3.4 Where the assumption of a continuous dose-response relationship is made, by definition some amount of adverse effect might be present at the NOEC, but is not great enough to be detected by hypothesis testing.

9.2.3.5 Where the assumption of a noncontinuous dose-response relationship is made, the NOEC would indeed be an estimate of a "safe" or "no-effect" concentration if the amount of adverse effect that appears at the threshold is great enough to test as statistically significantly different from the controls in the face of all aspects of the experimental design mentioned above. If, however, the amount of adverse effect at the threshold were not great enough to test as statistically different, some amount of adverse effect might be present at the NOEC. In any case, the estimate of the NOEC with hypothesis testing is always dependent on the aspects of the experimental design mentioned above. For this reason, the reporting and examination of some measure of the sensitivity of the test (either the minimum significant difference or the percent change from the control that this minimum difference represents) is extremely important.

9.2.4 In summary, the assessment of a "safe" or "no-effect" concentration cannot be made from the results of statistical analysis alone, unless (1) the assumptions of a strict threshold model are accepted, and (2) it is assumed that the amount of adverse effect present at the threshold is statistically detectable by hypothesis testing. In this case, estimates obtained from a statistical analysis are indeed estimates of a "no-effect" concentration. If the assumptions are not deemed tenable, then estimates from a statistical analysis can only be used in conjunction with an assessment from a biological standpoint of what magnitude of adverse effect constitutes a "safe" concentration. In this instance, a "safe" concentration is not necessarily a truly "no-effect" concentration, but rather a concentration at which the effects are judged to be of no biological significance.

9.2.5 A better understanding of the relationship between endpoints derived by hypothesis testing (NOECs) and point estimation techniques (LCs, ICs, and ECs) would be very helpful in choosing methods of data analysis. Norberg-King (1991) reported that the IC25s were comparable to the NOECs for 23 effluent and reference toxicant data sets analyzed. The data sets included short-term chronic toxicity tests for the sea urchin, *Arbacia punctulata*, the sheepshead minnow, *Cyprinodon variegatus*, and the red macroalga, *Champia parvula*. Birge et al. (1985) reported that LC1s derived from Probit Analyses of data from short-term embryo-larval tests with reference toxicants were comparable to NOECs for several organisms. Similarly, USEPA (1988d) reported that the IC25s were comparable to the NOECs for a set of daphnia, *Ceriodaphnia dubia* chronic tests with a single reference toxicant. However, the scope of these comparisons was very limited, and sufficient information is not yet available to establish an overall

relationship between these two types of endpoints, especially when derived from effluent toxicity test data.

9.3 PRECISION

9.3.1 HYPOTHESIS TESTS

9.3.1.1 When hypothesis tests are used to analyze toxicity test data, it is not possible to express precision in terms of a commonly used statistic. The results of the test are given in terms of two endpoints, the No-Observed-Effect Concentration (NOEC) and the Lowest-Observed-Effect Concentration (LOEC). The NOEC and LOEC are limited to the concentrations selected for the test. The width of the NOEC-LOEC interval is a function of the dilution series, and differs greatly depending on whether a dilution factor of 0.3 or 0.5 is used in the test design. Therefore, **USEPA recommends the use of the ≥ 0.5 dilution factor** (see Section 4, Quality Assurance). It is not possible to place confidence limits on the NOEC and LOEC derived from a given test, and it is difficult to quantify the precision of the NOEC-LOEC endpoints between tests. If the data from a series of tests performed with the same toxicant, toxicant concentrations, and test species, were analyzed with hypothesis tests, precision could only be assessed by a qualitative comparison of the NOEC-LOEC intervals, with the understanding that maximum precision would be attained if all tests yielded the same NOEC-LOEC interval. In practice, the precision of results of repetitive chronic tests is considered acceptable if the NOECs vary by no more than one concentration interval above or below a central tendency. Using these guidelines, the "normal" range of NOECs from toxicity tests using a 0.5 dilution factor (two-fold difference between adjacent concentrations), would be four-fold.

9.3.2 POINT ESTIMATION TECHNIQUES

9.3.2.1 Point estimation techniques have the advantage of providing a point estimate of the toxicant concentration causing a given amount of adverse (inhibiting) effect, the precision of which can be quantitatively assessed (1) within tests by calculation of 95% confidence limits, and (2) across tests by calculating a standard deviation and coefficient of variation.

9.4 DATA ANALYSIS

9.4.1 ROLE OF THE STATISTICIAN

9.4.1.1 The use of the statistical methods described in this manual for routine data analysis does not require the assistance of a statistician. However, the interpretation of the results of the analysis of the data from any of the toxicity tests described in this manual can become problematic because of the inherent variability and sometimes unavoidable anomalies in biological data. If the data appear unusual in any way, or fail to meet the necessary assumptions, a statistician should be consulted. Analysts who are not proficient in statistics are strongly advised to seek the assistance of a statistician before selecting the method of analysis and using any of the results.

9.4.1.2 The statistical methods recommended in this manual are not the only possible methods of statistical analysis. Many other methods have been proposed

and considered. Certainly there are other reasonable and defensible methods of statistical analysis for this kind of toxicity data. Among alternative hypothesis tests some, like Williams' Test, require additional assumptions, while others, like the bootstrap methods, require computer-intensive computations. Alternative point estimations approaches most probably would require the services of a statistician to determine the appropriateness of the model (goodness of fit), higher order linear or nonlinear models, confidence intervals for estimates generated by inverse regression, etc. In addition, point estimation or regression approaches would require the specification by biologists or toxicologists of some low level of adverse effect that would be deemed acceptable or safe. The statistical methods contained in this manual have been chosen because they are (1) applicable to most of the different toxicity test data sets for which they are recommended, (2) powerful statistical tests, (3) hopefully "easily" understood by nonstatisticians, and (4) amenable to use without a computer, if necessary.

9.4.2 PLOTTING THE DATA

9.4.2.1 The data should be plotted, both as a preliminary step to help detect problems and unsuspected trends or patterns in the responses, and as an aid in interpretation of the results. Further discussion and plotted sets of data are included in the methods and the Appendices.

9.4.3 DATA TRANSFORMATIONS

9.4.3.1 Transformations of the data, (e.g., arc sine square root and logs), are used where necessary to meet assumptions of the proposed analyses, such as the requirement for normally distributed data.

9.4.4 INDEPENDENCE, RANDOMIZATION, AND OUTLIERS

9.4.4.1 Statistical independence among observations is a critical assumption in all statistical analysis of toxicity data. One of the best ways to ensure independence is to properly follow rigorous randomization procedures. Randomization techniques should be employed at the start of the test, including the randomization of the placement of test organisms in the test chambers and randomization of the test chamber location within the array of chambers. Discussions of statistical independence, outliers and randomization, and a sample randomization scheme, are included in Appendix A.

9.4.5 REPLICATION AND SENSITIVITY

9.4.5.1 The number of replicates employed for each toxicant concentration is an important factor in determining the sensitivity of chronic toxicity tests. Test sensitivity generally increases as the number of replicates is increased, but the point of diminishing returns in sensitivity may be reached rather quickly. The level of sensitivity required by a hypothesis test or the confidence interval for a point estimate will determine the number of replicates, and should be based on the objectives for obtaining the toxicity data.

9.4.5.2 In a statistical analysis of toxicity data, the choice of a particular analysis and the ability to detect departures from the assumptions of the analysis, such as the normal distribution of the data and homogeneity of variance, is also dependent on the number of replicates. More than the minimum number of replicates may be required in situations where it is imperative to obtain optimal statistical results, such as with tests used in enforcement cases or when it is not possible to repeat the tests. For example, when the data are analyzed by hypothesis testing, the nonparametric alternatives cannot be used unless there are at least four replicates at each toxicant concentration.

9.4.6 RECOMMENDED ALPHA LEVELS

9.4.6.1 The data analysis examples included in the manual specify an alpha level of 0.01 for testing the assumptions of hypothesis tests and an alpha level of 0.05 for the hypothesis tests themselves. These levels are common and well accepted levels for this type of analysis and are presented as a recommended minimum significance level for toxicity data analysis.

9.5 CHOICE OF ANALYSIS

9.5.1 The recommended statistical analysis of most data from chronic toxicity tests with aquatic organisms follows a decision process illustrated in the flowchart in Figure 2. An initial decision is made to use point estimation techniques (the Probit Analysis, the Spearman-Karber Method, the Trimmed Spearman-Karber Method, the Graphical Method, or Linear Interpolation Method) and/or to use hypothesis testing (Dunnett's Test, the t test with the Bonferroni adjustment, Steel's Many-one Rank Test, or Wilcoxon Rank Sum Test with the Bonferroni adjustment). **NOTE: For the NPDES Permit Program, the point estimation techniques are the preferred statistical methods in calculating end points for effluent toxicity tests.** If hypothesis testing is chosen, subsequent decisions are made on the appropriate procedure for a given set of data, depending on the results of tests of assumptions, as illustrated in the flowchart. A specific flow chart is included in the analysis section for each test.

9.5.2 Since a single chronic toxicity test might yield information on more than one parameter (such as survival, growth, and reproduction), the lowest estimate of a "no-observed-effect concentration" for any of the responses would be used as the "no-observed-effect concentration" for each test. It follows logically that in the statistical analysis of the data, concentrations that had a significant toxic effect on one of the observed responses would not be subsequently tested for an effect on some other response. This is one reason for excluding concentrations that have shown a statistically significant reduction in survival from a subsequent hypothesis test for effects on another parameter such as reproduction. A second reason is that the exclusion of such concentrations usually results in a more powerful and appropriate statistical analysis. In performing the point estimation techniques recommended in this manual, an all-data approach is used. For example, data from concentrations above the NOEC for survival are included in determining IC_p estimates using the Linear Interpolation Method.

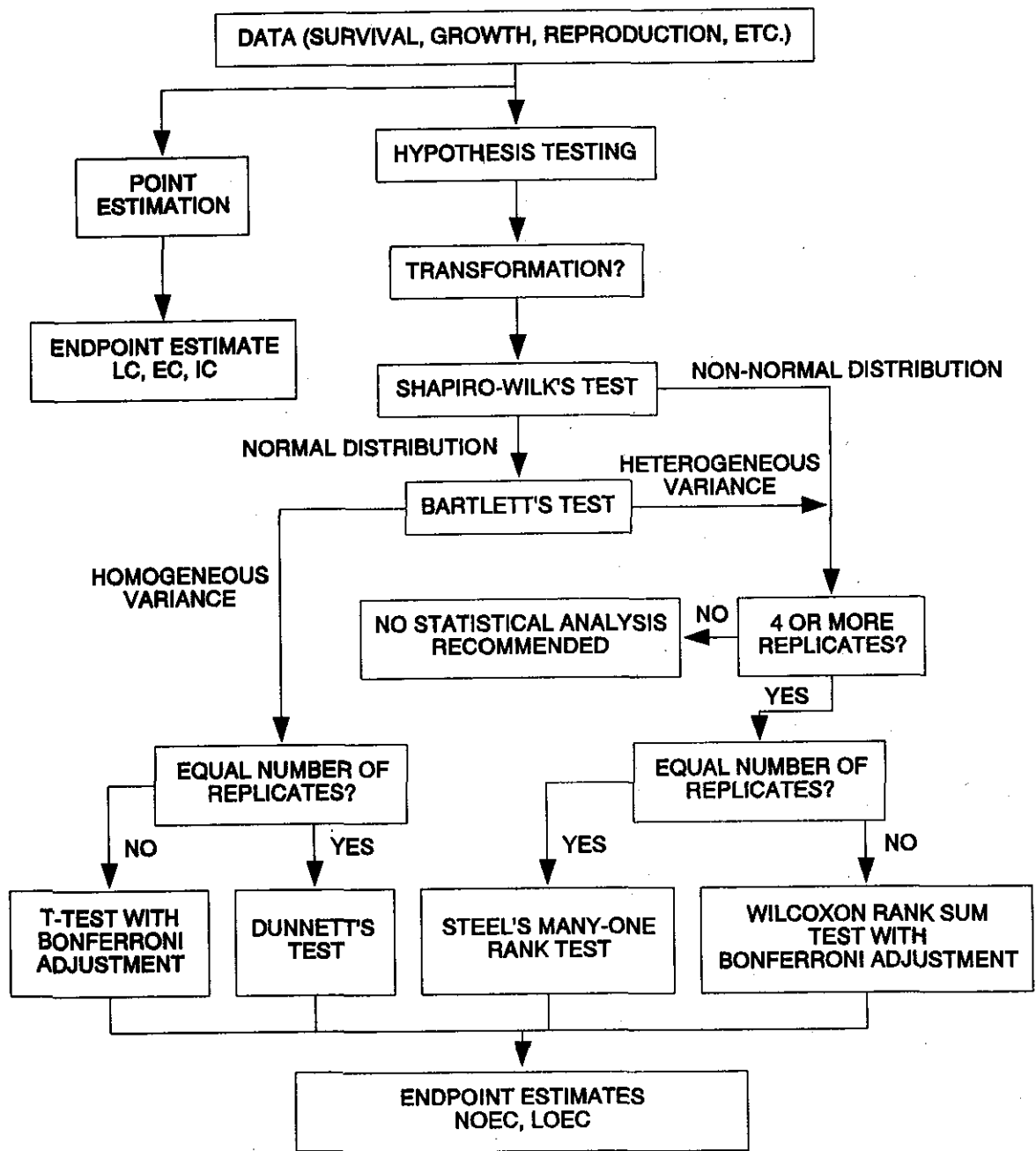

Figure 2. Flowchart for statistical analysis of test data.

9.5.3 ANALYSIS OF GROWTH AND REPRODUCTION DATA

9.5.3.1 Growth data from the sheepshead minnow, *Cyprinodon variegatus*, and inland silverside, *Menidia beryllina*, larval survival and growth tests, and the mysid, *Mysidopsis bahia*, survival, growth, and fecundity test, are analyzed using hypothesis testing according to the flowchart in Figure 2. The above mentioned growth data may also be analyzed by generating a point estimate with the Linear Interpolation Method. Data from effluent concentrations that have tested significantly different from the control for survival are excluded from further hypothesis tests concerning growth effects. Growth is defined as the change in dry weight of the original number of test organisms when group weights are obtained. When analyzing the data using point estimating techniques, data from all concentrations are included in the analysis.

9.5.3.2 Fecundity data from the mysid, *Mysidopsis bahia*, test may be analyzed using hypothesis testing after an arc sine transformation according to the flowchart in Figure 2. The fecundity data from the mysid test may also be analyzed by generating a point estimate with the Linear Interpolation Method.

9.5.3.3 Reproduction data from the red macroalga, *Champia parvula*, test are analyzed using hypothesis testing as illustrated in Figure 2. The reproduction data from the red macroalga test may also be analyzed by generating a point estimate with the Linear Interpolation Method.

9.5.4 ANALYSIS OF THE SEA URCHIN, *ARBACIA PUNCTULATA*, FERTILIZATION DATA

9.5.4.1 Data from the sea urchin, *Arbacia punctulata*, fertilization test may be analyzed by hypothesis testing after an arc sine transformation according to the flowchart in Figure 2. The fertilization data from the sea urchin test may also be analyzed by generating a point estimate with the Linear Interpolation Method.

9.5.5 ANALYSIS OF MORTALITY DATA

9.5.5.1 Mortality data are analyzed by Probit Analysis, if appropriate, or other point estimation techniques, (i.e., the Spearman-Kärber Method, the Trimmed Spearman-Kärber Method, or the Graphical Method) (see Appendices G-I) (see discussion below). The mortality data can also be analyzed by hypothesis testing, after an arc sine square root transformation (see Appendices B-F), according to the flowchart in Figure 2.

9.6 HYPOTHESIS TESTS

9.6.1 DUNNETT'S PROCEDURE

9.6.1.1 Dunnett's Procedure is used to determine the NOEC. The procedure consists of an analysis of variance (ANOVA) to determine the error term, which is then used in a multiple comparison procedure for comparing each of the treatment means with the control mean, in a series of paired tests (see Appendix C). Use of Dunnett's Procedure requires at least three replicates per treatment to check the assumptions of the test. In cases where the numbers of data points (replicates) for each concentration are not equal, a t test may be performed with

Bonferroni's adjustment for multiple comparisons (see Appendix D), instead of using Dunnett's Procedure.

9.6.1.2 The assumptions upon which the use of Dunnett's Procedure is contingent are that the observations within treatments are normally distributed, with homogeneity of variance. Before analyzing the data, these assumptions must be tested using the procedures provided in Appendix B.

9.6.1.3 If, after suitable transformations have been carried out, the normality assumptions have not been met, Steel's Many-one Rank Test should be used if there are four or more data points (replicates) per toxicant concentration. If the numbers of data points for each toxicant concentration are not equal, the Wilcoxon Rank Sum Test with Bonferroni's adjustment should be used (see Appendix F).

9.6.1.4 Some indication of the sensitivity of the analysis should be provided by calculating (1) the minimum difference between means that can be detected as statistically significant, and (2) the percent change from the control mean that this minimum difference represents for a given test.

9.6.1.5 A step-by-step example of the use of Dunnett's Procedure is provided in Appendix C.

9.6.2 T TEST WITH THE BONFERRONI ADJUSTMENT

9.6.2.1 The t test with the Bonferroni adjustment is used as an alternative to Dunnett's Procedure when the number of replicates is not the same for all concentrations. This test sets an upper bound of alpha on the overall error rate, in contrast to Dunnett's Procedure, for which the overall error rate is fixed at alpha. Thus, Dunnett's Procedure is a more powerful test.

9.6.2.2 The assumptions upon which the use of the t test with the Bonferroni adjustment is contingent are that the observations within treatments are normally distributed, with homogeneity of variance. These assumptions must be tested using the procedures provided in Appendix B.

9.6.2.3 The estimate of the safe concentration derived from this test is reported in terms of the NOEC. A step-by-step example of the use of a t-test with the Bonferroni adjustment is provided in Appendix D.

9.6.3 STEEL'S MANY-ONE RANK TEST

9.6.3.1 Steel's Many-one Rank Test is a multiple comparison procedure for comparing several treatments with a control. This method is similar to Dunnett's procedure, except that it is not necessary to meet the assumption of normality. The data are ranked, and the analysis is performed on the ranks rather than on the data themselves. If the data are normally or nearly normally distributed, Dunnett's Procedure would be more sensitive (would detect smaller differences between the treatments and control). For data that are not normally distributed, Steel's Many-one Rank Test can be much more efficient (Hodges and Lehmann, 1956).

9.6.3.2 It is necessary to have at least four replicates per toxicant concentration to use Steel's test. Unlike Dunnett's procedure, the sensitivity of this test cannot be stated in terms of the minimum difference between treatment means and the control mean that can be detected as statistically significant.

9.6.3.3 The estimate of the safe concentration is reported as the NOEC. A step-by-step example of the use of Steel's Many-One Rank Test is provided in Appendix E.

9.6.4 WILCOXON RANK SUM TEST WITH THE BONFERRONI ADJUSTMENT

9.6.4.1 The Wilcoxon Rank Sum Test is a nonparametric test for comparing a treatment with a control. The data are ranked and the analysis proceeds exactly as in Steel's Test except that Bonferroni's adjustment for multiple comparisons is used instead of Steel's tables. When Steel's test can be used (i.e., when there are equal numbers of data points per toxicant concentration), it will be more powerful (able to detect smaller differences as statistically significant) than the Wilcoxon Rank Sum Test with Bonferroni's adjustment.

9.6.4.2 The estimate of the safe concentration is reported as the NOEC. A step-by-step example of the use of the Wilcoxon Rank Sum Test with Bonferroni adjustment is provided in Appendix F.

9.6.5 A CAUTION IN THE USE OF HYPOTHESIS TESTING

9.6.5.1 If in the calculation of an NOEC by hypothesis testing, two tested concentrations cause statistically significant adverse effects, but an intermediate concentration did not cause statistically significant effects, the results should be used with extreme caution.

9.7 POINT ESTIMATION TECHNIQUES

9.7.1 PROBIT ANALYSIS

9.7.1.1 Probit Analysis is used to estimate an LC1, LC50, EC1, or EC50 and the associated 95% confidence interval. The analysis consists of adjusting the data for mortality in the control, and then using a maximum likelihood technique to estimate the parameters of the underlying log tolerance distribution, which is assumed to have a particular shape.

9.7.1.2 The assumption upon which the use of Probit Analysis is contingent is a normal distribution of log tolerances. If the normality assumption is not met, and at least two partial mortalities are not obtained, Probit Analysis should not be used. It is important to check the results of Probit Analysis to determine if use of the analysis is appropriate. The chi-square test for heterogeneity provides a good test of appropriateness of the analysis. The computer program (see discussion, Appendix H) checks the chi-square statistic calculated for the data set against the tabular value, and provides an error message if the calculated value exceeds the tabular value.

9.7.1.3 A discussion of Probit Analysis, and examples of computer program input and output, are found in Appendix H.

9.7.1.4 In cases where Probit Analysis is not appropriate, the LC50 and confidence interval may be estimated by the Spearman-Karber Method (Appendix I) or the Trimmed Spearman-Karber Method (Appendix J). If a test results in 100% survival and 100% mortality in adjacent treatments (all or nothing effect), the LC50 may be estimated using the Graphical Method (Appendix K).

9.7.2 LINEAR INTERPOLATION METHOD

9.7.2.1 The Linear Interpolation Method (see Appendix L) is a procedure to calculate a point estimate of the effluent or other toxicant concentration [Inhibition Concentration, (IC)] that causes a given percent reduction (e.g., 25%, 50%, etc.) in the reproduction, growth, fertilization, or fecundity of the test organisms. The procedure was designed for general applicability in the analysis of data from short-term chronic toxicity tests.

9.7.2.2 Use of the Linear Interpolation Method is based on the assumptions that the responses (1) are monotonically non-increasing (the mean response for each higher concentration is less than or equal to the mean response for the previous concentration), (2) follow a piece-wise linear response function, and (3) are from a random, independent, and representative sample of test data. The assumption for piece-wise linear response cannot be tested statistically, and no defined statistical procedure is provided to test the assumption for monotonicity. Where the observed means are not strictly monotonic by examination, they are adjusted by smoothing. In cases where the responses at the low toxicant concentrations are much higher than in the controls, the smoothing process may result in a large upward adjustment in the control mean.

9.7.2.3 The inability to test the monotonicity and piece wise linear response assumptions for this method makes it difficult to assess when the method is, or is not, producing reliable results. Therefore, the method should be used with caution when the results of a toxicity test approach an "all or nothing" response from one concentration to the next in the concentration series, and when it appears that there is a large deviation from monotonicity. See Appendix L for a more detailed discussion of the use of this method and a computer program available for performing calculations.

SECTION 10
REPORT PREPARATION

The toxicity data are reported, together with other appropriate data. The following general format and content are recommended for the report:

10.1 INTRODUCTION

1. Permit number
2. Toxicity testing requirements of permit
3. Plant location
4. Name of receiving water body
5. Contract Laboratory (if the test was performed under contract)
 - a. Name of firm
 - b. Phone number
 - c. Address

10.2 PLANT OPERATIONS

1. Product(s)
2. Raw materials
3. Operating schedule
4. Description of waste treatment
5. Schematic of waste treatment
6. Retention time (if applicable)
7. Volume of waste flow (MGD, CFS, GPM)
8. Design flow of treatment facility at time of sampling

10.3 SOURCE OF EFFLUENT, RECEIVING WATER, AND DILUTION WATER

1. Effluent Samples
 - a. Sampling point
 - b. Collection dates and times
 - c. Sample collection method
 - d. Physical and chemical data
 - e. Mean daily discharge on sample collection date
 - f. Lapsed time from sample collection to delivery
 - g. Sample temperature when received at the laboratory
2. Receiving Water Samples
 - a. Sampling point
 - b. Collection dates and times
 - c. Sample collection method
 - d. Physical and chemical data
 - e. Tide stages
 - f. Sample temperature when received at the laboratory
 - g. Lapsed time from sample collection to delivery

3. Dilution Water Samples
 - a. Source
 - b. Collection date and time
 - c. Pretreatment
 - d. Physical and chemical characteristics

10.4 TEST METHODS

1. Toxicity test method used (title, number, source)
2. Endpoint(s) of test
3. Deviation(s) from reference method, if any, and the reason(s)
4. Date and time test started
5. Date and time test terminated
6. Type of volume and test chambers
7. Volume of solution used per chamber
8. Number of organisms used per test chamber
9. Number of replicate test chambers per treatment
10. Acclimation of test organisms (temperature and salinity mean and range)
11. Test temperature (mean and range)
12. Specify if aeration was needed
13. Feeding frequency, and amount and type of food
14. Test salinity (mean and range)

10.5 TEST ORGANISMS

1. Scientific name and how determined
2. Age
3. Life stage
4. Mean length and weight (where applicable)
5. Source
6. Diseases and treatment (where applicable)
7. Taxonomic key used for species identification

10.6 QUALITY ASSURANCE

1. Reference toxicant used routinely; source
2. Date and time of most recent reference toxicant test; test results and current control (cusum) chart
3. Dilution water used in reference toxicant test
4. Results (NOEC or, where applicable, LOEC, LC50, EC50, IC25 and/or IC50)
5. Physical and chemical methods used

10.7 RESULTS

1. Provide raw toxicity data in tabular form, including daily records of affected organisms in each concentration (including controls), and plots of toxicity data
2. Provide table of LC50s, NOECs, IC25, IC50, etc.
3. Indicate statistical methods to calculate endpoints
4. Provide summary table of physical and chemical data
5. Tabulate QA data

10.8 CONCLUSIONS AND RECOMMENDATIONS

1. Relationship between test endpoints and permit limits.
2. Action to be taken.

SECTION 11

TEST METHOD

SHEEPSHEAD MINNOW, *CYPRINODON VARIEGATUS* LARVAL SURVIVAL AND GROWTH TEST METHOD 1004.0

11.1 SCOPE AND APPLICATION

11.1.1 This method, adapted in part from USEPA (1987b), estimates the chronic toxicity of effluents and receiving waters to the sheepshead minnow, *Cyprinodon variegatus*, using newly hatched larvae in a seven-day, static-renewal test. The effects include the synergistic, antagonistic, and additive effects of all the chemical, physical, and biological components which adversely affect the physiological and biochemical functions of the test species.

11.1.2 Daily observations on mortality make it possible to also calculate acute toxicity for desired exposure periods (i.e., 24-h, 48-h, 96-h LC50s).

11.1.3 Detection limits of the toxicity of an effluent or chemical are organism dependent.

11.1.4 Brief excursions in toxicity may not be detected using 24-h composite samples. Also, because of the long sample collection period involved in composite sampling, and because the test chambers are not sealed, highly volatile and highly degradable toxicants present in the source may not be detected in the test.

11.1.5 This method is commonly used in one of two forms: (1) a definitive test, consisting of a minimum of five effluent concentrations and a control, and (2) a receiving water test(s), consisting of one or more receiving water concentrations and a control.

11.2 SUMMARY OF METHOD

11.2.1 Sheepshead minnow, *Cyprinodon variegatus*, larvae (preferably less than 24-h old) are exposed in a static renewal system for seven days to different concentrations of effluent or to receiving water. Test results are based on the survival and weight of the larvae.

11.3 INTERFERENCES

11.3.1 Toxic substances may be introduced by contaminants in dilution water, glassware, sample hardware, and testing equipment (see Section 5, Facilities, Equipment, and Supplies).

11.3.2 Adverse effects of low dissolved oxygen concentrations (DO), high concentrations of suspended and/or dissolved solids, and extremes of pH, may mask the effects of toxic substances.

11.3.3 Improper effluent sampling and handling may adversely affect test results (see Section 8, Effluent and Receiving Water Sampling, Sample Handling, and Sample Preparation for Toxicity Tests).

11.3.4 Pathogenic and/or predatory organisms in the dilution water and effluent may affect test organism survival, and confound test results.

11.3.5 Food added during the test may sequester metals and other toxic substances and reduce the apparent toxicity of the test substance. However, in a growth test the nutritional needs of the organisms must be satisfied, even if feeding has the potential to confound test results.

11.4 SAFETY

11.4.1 See Section 3, Health and Safety.

11.5 APPARATUS AND EQUIPMENT

11.5.1 Facilities for holding and acclimating test organisms.

11.5.2 Brine shrimp, *Artemia*, culture unit -- see Subsection 11.6.14 below and Section 4, Quality Assurance.

11.5.3 Sheepshead minnow culture unit -- see Subsection 11.6.15 below. The maximum number of larvae required per test will range from a maximum of 360, if 15 larvae are used in each of four replicates, to a minimum of 180 per test, if 10 larvae are used in each of three replicates. It is preferable to obtain the test organisms from an in-house culture unit. If it is not feasible to culture fish in-house, embryos or newly hatched larvae can be obtained from other sources if shipped in well oxygenated saline water in insulated containers.

11.5.4 Samplers -- automatic sampler, preferably with sample cooling capability, that can collect a 24-h composite sample of 5 L.

11.5.5 Environmental chamber or equivalent facility with temperature control ($25 \pm 1^\circ\text{C}$).

11.5.6 Water purification system -- Millipore Milli-Q®, deionized water (DI) or equivalent.

11.5.7 Balance -- Analytical, capable of accurately weighing to 0.00001 g.

11.5.8 Reference weights, Class S -- for checking performance of balance. Weights should bracket the expected weights of the weighing pans and the expected weights of the pans plus fish.

11.5.9 Drying oven -- 50-105°C range, for drying larvae.

11.5.10 Air pump -- for oil-free air supply.

- 11.5.11 Air lines, and air stones -- for aerating water containing embryos or larvae, or for supplying air to test solutions with low DO.
- 11.5.12 Meters, pH and DO -- for routine physical and chemical measurements.
- 11.5.13 Standard or micro-Winkler apparatus -- for determining DO (optional).
- 11.5.14 Dissecting microscope -- for checking embryo viability.
- 11.5.15 Desiccator -- for holding dried larvae.
- 11.5.16 Light box -- for counting and observing larvae.
- 11.5.17 Refractometer -- for determining salinity.
- 11.5.18 Thermometers, glass or electronic, laboratory grade -- for measuring water temperatures.
- 11.5.19 Thermometers, bulb-thermograph or electronic-chart type -- for continuously recording temperature.
- 11.5.20 Thermometer, National Bureau of Standards Certified (see USEPA Method 170.1, USEPA, 1979b) -- to calibrate laboratory thermometers.
- 11.5.21 Test chambers -- four (minimum of three) for each concentration and control. Borosilicate glass 1000 mL beakers or modified Norberg and Mount (1985) glass chambers used in the short-term inland silverside test may be used. It is recommended that each chamber contain a minimum of 50 mL/larvae and allow adequate depth of test solution (5.0 cm). To avoid potential contamination from the air and excessive evaporation of test solutions during the test, the chambers should be covered with safety glass plates or sheet plastic (6 mm thick).
- 11.5.22 Beakers -- six Class A, borosilicate glass or non-toxic plasticware, 1000 mL for making test solutions.
- 11.5.23 Wash bottles -- for deionized water, for washing embryos from substrates and containers, and for rinsing small glassware and instrument electrodes and probes.
- 11.5.24 Crystallization dishes, beakers, culture dishes (1 L), or equivalent -- for incubating embryos.
- 11.5.25 Volumetric flasks and graduated cylinders -- Class A, borosilicate glass or non-toxic plastic labware, 10-1000 mL for making test solutions.
- 11.5.26 Separatory funnels, 2-L -- two to four for culturing *Artemia* nauplii.
- 11.5.27 Pipets, volumetric -- Class A, 1-100 mL.
- 11.5.28 Pipets, automatic -- adjustable, 1-100 mL.

- 11.5.29 Pipets, serological -- 1-10 mL, graduated.
- 11.5.30 Pipet bulbs and fillers -- PROPIPET®, or equivalent.
- 11.5.31 Droppers, and glass tubing with fire polished edges, 4 mm ID -- for transferring larvae.
- 11.5.32 Siphon with bulb and clamp -- for cleaning test chambers.
- 11.5.33 Forceps -- for transferring dead larvae to weighing boats.
- 11.5.34 NITEX® or stainless steel mesh sieves ($\leq 150 \mu\text{m}$, $500 \mu\text{m}$, 3 to 5 mm) -- for collecting *Artemia* nauplii and fish embryos, and for spawning baskets, respectively. (Nitex® is available from Sterling Marine Products, 18 Label Street, Montclair, NJ 07042; 201-783-9800).

11.6 REAGENTS AND CONSUMABLE MATERIALS

- 11.6.1 Sample containers -- for sample shipment and storage (see Section 8, Effluent and Receiving Water Sampling, Sample Handling, and Sample Preparation for Toxicity Tests).
- 11.6.2 Data sheets (one set per test) -- for data recording.
- 11.6.3 Vials, marked -- 18-24 per test, containing 4% formalin or 70% ethanol, to preserve larvae (optional).
- 11.6.4 Weighing pans, aluminum -- 18-24 per test.
- 11.6.5 Tape, colored -- for labelling test chambers.
- 11.6.6 Markers, waterproof -- for marking containers, etc.
- 11.6.7 Buffers, pH 4, pH 7, and pH 10 (or as per instructions of instrument manufacturer) -- for standards and calibration check (see USEPA Method 150.1, USEPA, 1979b).
- 11.6.8 Membranes and filling solutions for dissolved oxygen probe (see USEPA Method 360.1, USEPA, 1979b), or reagents -- for modified Winkler analysis.
- 11.6.9 Laboratory quality control samples and standards -- for calibration of the above methods.
- 11.6.10 Reference toxicant solutions -- see Section 4, Quality Assurance.
- 11.6.11 Ethanol (70%) or formalin (4%) -- for use as a preservative for the fish larvae.
- 11.6.12 Reagent water -- defined as distilled or deionized water that does not contain substances which are toxic to the test organisms.

11.6.13 Effluent, receiving water, and dilution water -- see Section 7, Dilution Water, and Section 8, Effluent and Receiving Water Sampling, Sample Handling, and Sample Preparation for Toxicity Tests.

11.6.13.1 Saline test and dilution water -- The salinity of the test water must be in the range of 20 to 32‰. The salinity should vary by no more than $\pm 2\%$ among the chambers on a given day. If effluent and receiving water tests are conducted concurrently, the salinities of these tests should be similar. This test is not recommended for salinities less than 20‰.

11.6.13.2 The overwhelming majority of industrial and sewage treatment effluents entering marine and estuarine systems contain little or no measurable salts. Exposure of sheepshead minnow larvae to these effluents will require adjustments in the salinity of the test solutions. It is important to maintain a constant salinity across all treatments. In addition, it may be desirable to match the test salinity with that of the receiving water. Two methods are available to adjust salinities -- a hypersaline brine derived from natural seawater or artificial sea salts.

11.6.13.3 Hypersaline brine (HSB): (HSB) has several advantages that make it desirable for use in toxicity testing. It can be made from any high quality, filtered seawater by evaporation, and can be added to the effluent or to deionized water to increase the salinity. HSB derived from natural seawater contains the necessary trace metals, biogenic colloids, and some of the microbial components necessary for adequate growth, survival, and/or reproduction of marine and estuarine organisms, and may be stored for prolonged periods without any apparent degradation. However, if 100‰ HSB is used as a diluent, the maximum concentration of effluent that can be tested will be 80% at 20‰ salinity and 70% at 30‰ salinity.

11.6.13.3.1 The ideal container for making brine from natural seawater is one that (1) has a high surface to volume ratio, (2) is made of a non-corrosive material, and (3) is easily cleaned (fiberglass containers are ideal). Special care should be used to prevent any toxic materials from coming in contact with the seawater being used to generate the brine. If a heater is immersed directly into the seawater, ensure that the heater materials do not corrode or leach any substances that would contaminate the brine. One successful method used is a thermostatically controlled heat exchanger made from fiberglass. If aeration is used, use only oil-free air compressors to prevent contamination.

11.6.13.3.2 Before adding seawater to the brine generator, thoroughly clean the generator, aeration supply tube, heater, and any other materials that will be in direct contact with the brine. A good quality biodegradable detergent should be used, followed by several (at least three) thorough deionized water rinses.

11.6.13.3.3 High quality (and preferably high salinity) seawater should be filtered to at least 10 μm before placing into the brine generator. Water should be collected on an incoming tide to minimize the possibility of contamination.

11.6.13.3.4 The temperature of the seawater is increased slowly to 40°C. The water should be aerated to prevent temperature stratification and to increase water evaporation. The brine should be checked daily (depending on volume being generated) to ensure that the salinity does not exceed 100‰ and that the temperature does not exceed 40°C. Additional seawater may be added to the brine to obtain the volume of brine required.

11.6.13.3.5 After the required salinity is attained, the HSB should be filtered a second time through a 1 µm filter and poured directly into portable containers (20-L cubitainers or polycarbonate water cooler jugs are suitable). The containers should be capped and labelled with the date the HSB was generated and its salinity. Containers of HSB should be stored in the dark and maintained at room temperature until used.

11.6.13.3.6 If a source of HSB is available, test solutions can be made by following the directions below. Thoroughly mix together the deionized water and HSB before adding the effluent.

11.6.13.3.7 Divide the salinity of the HSB by the expected test salinity to determine the proportion of deionized water to brine. For example, if the salinity of the brine is 100‰ and the test is to be conducted at 20‰, $100‰ \div 20‰ = 5.0$. The proportion of brine is 1 part in 5 (one part brine to four parts deionized water). To make 1 L of seawater at 20‰ salinity from a HSB of 100‰, divide 1 L (1000 mL) by 5.0. The result, 200 mL, is the quantity of brine needed to make 1 L of seawater. The difference, 800 mL, is the quantity of deionized water required.

11.6.13.4 Artificial sea salts: FORTY FATHOMS® brand sea salts (Marine Enterprises, Inc., 8755 Mylander Lane, Baltimore, MD 21204; 301-321-1189) have been used successfully at the EMSL-Cincinnati to maintain and spawn sheephead minnows and perform the larval survival and growth test (see Section 7, Dilution Water). HW MARINEMIX® (Hawaiian Marine Imports, Inc., P.O. Box 218687, Houston, TX 77218; 713-492-7864) sea salts have been used successfully at the USEPA Region 6 Houston Laboratory to maintain and spawn sheephead minnows and perform the larval growth and survival test and the embryo-larval survival and teratogenicity test. In addition, a slightly modified version of the GP2 medium (Spotte et al., 1984) has been successfully used to perform the sheephead minnow survival and growth test (Table 1). Artificial sea salts may be used for culturing sheephead minnows and for the larval survival and growth test if the criteria for acceptability of test data are satisfied (see Subsection 11.12).

11.6.13.4.1 Synthetic sea salts are packaged in plastic bags and mixed with deionized water or equivalent. The instructions on the package of sea salts should be followed carefully, and the salts should be mixed in a separate container -- not in the culture tank. The deionized water used in hydration should be in the temperature range of 21-26°C. Seawater made from artificial sea salts is conditioned (Spotte, 1973; Spotte et al., 1984; Bower, 1983) before it is used for culturing or testing. After adding the water, place an air stone in the container, cover, and aerate the solution mildly for 24 h before use.

11.6.13.4.2 The GP2 reagent grade chemicals (Table 1) should be mixed with deionized (DI) water or its equivalent in a container other than the culture or testing tanks. The deionized water used for hydration should be between 21-26°C. The artificial seawater must be conditioned (aerated) for 24 h before use as the testing medium. If the solution is to be autoclaved, sodium bicarbonate is added after the solution has cooled. A stock solution of sodium bicarbonate is made up by dissolving 33.6 g NaHCO₃ in 500 mL of deionized water. Add 2.5 mL of this stock solution for each liter of the GP2 artificial seawater.

TABLE 1. REAGENT GRADE CHEMICALS USED IN THE PREPARATION OF GP2 ARTIFICIAL SEAWATER FOR THE SHEEPSHEAD MINNOW, *CYPRINODON VARIEGATUS*, TOXICITY TEST^{1,2,3}

Compound	Concentration (g/L)	Amount (g) Required for 20 L
NaCl	21.03	420.6
Na ₂ SO ₄	3.52	70.4
KCl	0.61	12.2
KBr	0.088	1.76
Na ₂ B ₄ O ₇ · 10 H ₂ O	0.034	0.68
MgCl ₂ · 6 H ₂ O	9.50	190.0
CaCl ₂ · 2 H ₂ O	1.32	26.4
SrCl ₂ · 6 H ₂ O	0.02	0.400
NaHCO ₃	0.17	3.40

¹ Modified GP2 from Spotte et al. (1984).

² The constituent salts and concentrations were taken from USEPA (1990b). The salinity is 30.89 g/L.

³ GP2 can be diluted with deionized (DI) water to the desired test salinity.

11.6.14 BRINE SHRIMP, *ARTEMIA*, NAUPLII -- for feeding cultures and test organisms

11.6.14.1 Newly-hatched *Artemia* nauplii (see USEPA, 1993a) are used as food for sheepshead minnow larvae in toxicity tests and in the maintenance of continuous stock cultures. Although there are many commercial sources of brine shrimp cysts, the Brazilian or Colombian strains are currently preferred because the supplies examined have had low concentrations of chemical residues and produce nauplii of suitably small size. For commercial sources of brine shrimp, *Artemia*, cysts, see Table 2 of Section 5, Facilities, Equipment, and Supplies and Section 4, Quality Assurance, Subsection 4.8.

11.6.14.2 Each new batch of *Artemia* cysts must be evaluated for size (Vanhaecke and Sorgeloos, 1980, and Vanhaecke et al., 1980) and nutritional suitability (Leger et al., 1985, and Leger et al., 1986) against known suitable reference cysts by performing a side-by-side larval growth test using the "new" and "reference" cysts. The "reference" cysts used in the suitability test may be a previously tested and acceptable batch of cysts, or may be obtained from the Quality Assurance Research Division, Environmental Monitoring Systems Laboratory, Cincinnati, OH 45268; 513-569-7325. A sample of newly-hatched *Artemia* nauplii from each new batch of cysts should be chemically analyzed. The *Artemia* cysts should not be used if the concentration of total organochlorine pesticides exceeds 0.15 $\mu\text{g/g}$ wet weight or the total concentration of organochlorine pesticides plus PCBs exceeds 0.30 $\mu\text{g/g}$ wet weight. (For analytical methods see USEPA, 1982.)

11.6.14.3 *Artemia* nauplii are obtained as follows:

1. Add 1 L of seawater, or a solution prepared by adding 35.0 g uniodized salt (NaCl) or artificial sea salts to 1 L of deionized water, to a 2-L separatory funnel, or equivalent.
2. Add 10 mL *Artemia* cysts to the separatory funnel and aerate for 24 h at 27°C. (Hatching time varies with incubation temperature and the geographic strain of *Artemia* used (USEPA, 1985a; USEPA, 1993a; ASTM, 1993).
3. After 24 h, cut off the air supply in the separatory funnel. *Artemia* nauplii are phototactic, and will concentrate at the bottom of the funnel if it is covered for 5-10 minutes. To prevent mortality, do not leave the concentrated nauplii at the bottom of the funnel more than 10 min without aeration.
4. Drain the nauplii into a beaker or funnel fitted with a $\leq 150 \mu\text{m}$ NITEX® or stainless steel screen, and rinse with seawater or equivalent before use.

11.6.14.4 Testing *Artemia* nauplii as food for toxicity test organisms.

11.6.14.4.1 The primary criterion for acceptability of each new supply of brine shrimp cysts is the ability of the nauplii to support good survival and growth of the sheepshead minnow larvae (see Subsection 11.12). The larvae used to evaluate the suitability of the brine shrimp nauplii must be of the same geographical origin, species, and stage of development as those used routinely in the toxicity tests. Sufficient data to detect differences in survival and growth should be obtained by using three replicate test vessels, each containing a minimum of 15 larvae, for each type of food.

11.6.14.4.2 The feeding rate and frequency, test vessels, volume of control water, duration of the test, and age of the nauplii at the start of the test, should be the same as used for the routine toxicity tests.

11.6.14.4.3 Results of the brine shrimp nutrition assay, where there are only two treatments, can be evaluated statistically by use of a t test. The "new" food is acceptable if there are no statistically significant differences in the survival and growth of the larvae fed the two sources of nauplii.

11.6.15 TEST ORGANISMS, SHEEPSHEAD MINNOWS, *CYPRINODON VARIEGATUS*

11.6.15.1 Brood Stock

11.6.15.1.1 Adult sheepshead minnows for use as brood stock may be obtained by seine in Gulf of Mexico and Atlantic coast estuaries, from commercial sources, or from young fish raised to maturity in the laboratory. Feral brood stocks and first generation laboratory fish are preferred, to minimize inbreeding.

11.6.15.1.2 To detect disease and to allow time for acute mortality due to the stress of capture, field-caught adults are observed in the laboratory a minimum of two weeks before using as a source of gametes. Injured or diseased fish are discarded.

11.6.15.1.3 Sheepshead minnows can be continuously cultured in the laboratory from eggs to adults. The larvae, juvenile, and adult fish should be kept in appropriate size rearing tanks, maintained at ambient laboratory temperature. The larvae should be fed sufficient newly-hatched *Artemia* nauplii daily to assure that live nauplii are always present. Juveniles are fed frozen adult brine shrimp and a commercial flake food, such as TETRA SM-80®, available from Tetra Sales (U.S.A.), 201 Tabor Rd, Morris Plains, NJ 07950; 800-526-0650, or MARDEL AQUARIAN® Tropical Fish Flakes, available from Mardel Laboratories, Inc., 1958 Brandon Court, Glendale Heights, IL 60139; 312-351-0606, or equivalent. Adult fish (age one month) are fed flake food three or four times daily, supplemented with frozen adult brine shrimp.

11.6.15.1.3.1 Sheepshead minnows reach sexual maturity in three-to-five months after hatch, and have an average standard length of approximately 27 mm for females and 34 mm for males. At this time, the males begin to exhibit sexual dimorphism and initiate territorial behavior. When the fish reach sexual maturity and are to be used for natural spawning, the temperature should be controlled at 18-20°C.

11.6.15.1.4 Adults can be maintained in natural or artificial seawater in a flow-through or recirculating, aerated system consisting of an all-glass aquarium, or a "Living Stream" (Figid Unit, Inc., 3214 Sylvania Ave, Toledo, OH 43613; 419-474-6971), or equivalent.

11.6.15.1.5 The system is equipped with an undergravel or outside biological filter of shells Spotte (1973) or Bower (1983) for conditioning the biological filter), or a cartridge filter, such as a MAGNUM® Filter, available from Carolina Biological Supply Co., Burlington, NC 27215; 800-334-5551, or an EHEIM® Filter, available from Hawaiian Marine Imports Inc., P.O. Box 218687, Houston, TX 77218; 713-492-7864, or equivalent, at a salinity of 20-30‰ and a photoperiod of 16 h light/8 h dark.

11.6.15.2 Obtaining Embryos for Toxicity Tests (See USEPA, 1978)

11.6.15.2.1 Embryos can be shipped to the laboratory from an outside source or obtained from adults held in the laboratory. Ripe eggs can be obtained either by natural spawning or by intraperitoneal injection of the females with

human chorionic gonadotrophin (HCG) hormone, available from United States Biochemical Corporation, Cleveland, OH 44128; 216-765-5000. If the culturing system for adults is temperature controlled, natural spawning can be induced. Natural spawning is preferred because repeated spawnings can be obtained from the same brood stock, whereas with hormone injection, the brood stock is sacrificed in obtaining gametes.

11.6.15.2.2 It should be emphasized that the injection and hatching schedules given below are to be used only as guidelines. Response to the hormone varies from stock to stock and with temperature. Time to hatch and percent viable hatch also vary among stocks and among batches of embryos obtained from the same stock, and are dependent on temperature, DO, and salinity. The coordination of spawning and hatching is further complicated by the fact that, even under the most ideal conditions, embryos spawned over a 24-h period may hatch over a 72-h period. Therefore, it is advisable (especially if natural spawning is used) to obtain fertilized eggs over several days to ensure that a sufficient number of newly hatched larvae (less than 24 h old) will be available to initiate a test.

11.6.15.2.3 Forced Spawning

11.6.15.2.3.1 HCG is reconstituted with sterile saline or Ringer's solution immediately before use. The standard HCG vial contains 1,000 IU to be reconstituted in 10 mL of saline. Freeze-dried HCG which comes with premeasured and sterilized saline is the easiest to use. Use of a 50 IU dose requires injection of 0.05 mL of reconstituted hormone solution. Reconstituted HCG may be used for several weeks if kept in the refrigerator.

11.6.15.2.3.2 Each female is injected intraperitoneally with 50 IU HCG on two consecutive days, starting at least 10 days prior to the beginning of a test. Two days following the second injection, eggs are stripped from the females and mixed with sperm derived from excised macerated testes. At least ten females and five males are used per test to ensure that there is a sufficient number (400) of viable embryos.

11.6.15.2.3.3 HCG is injected into the peritoneal cavity, just below the skin, using as small a needle as possible. A 50 IU dose is recommended for females approximately 27 mm in standard length. A larger or smaller dose may be used for fish which are significantly larger or smaller than 27 mm. With injections made on days one and two, females which are held at 25°C should be ready for stripping on days 4, 5, and 6. Ripe females should show pronounced abdominal swelling, and release at least a few eggs in response to a gentle squeeze. Injected females should be isolated from males. It may be helpful if fish that are to be injected are maintained at 20°C before injection, and the temperature raised to 25°C on the day of the first injection.

11.6.15.2.3.4 Prepare the testes immediately before stripping the eggs from the females. Remove the testes from three-to-five males. The testes are paired, dark grey organs along the dorsal midline of the abdominal cavity. If the head of the male is cut off and pulled away from the rest of the fish, most of the internal organs can be pulled out of the body cavity, leaving the testes behind. The testes are placed in a few mL of seawater until the eggs are ready.

11.6.15.2.3.5 Strip the eggs from the females, into a dish containing 50-100 mL of seawater, by firmly squeezing the abdomen. Sacrifice the females and remove the ovaries if all the ripe eggs do not flow out freely. Break up any clumps of ripe eggs and remove clumps of ovarian tissue and underripe eggs. Ripe eggs are spherical, approximately 1 mm in diameter, and almost clear.

11.6.15.2.3.6 While being held over the dish containing the eggs, the testes are macerated in a fold of NITEX® screen (250-500 μm mesh) dampened with seawater. The testes are then rinsed with seawater to remove the sperm from tissue, and the remaining sperm and testes are washed into the dish. Let the eggs and milt stand together for 10-15 min, swirling occasionally.

11.6.15.2.3.7 Pour the contents of the dish into a beaker, and insert an airstone. Aerate gently, such that the water moves slowly over the eggs, and incubate at 25°C for 60-90 min. After incubation, wash the eggs on a NITEX® screen and resuspend them in clean seawater. Examine the eggs periodically under a dissecting microscope until they are in the 2-8 cell stage. (The stage at which it is easiest to tell the developing embryos from the abnormal embryos and unfertilized eggs; see Figure 1). The eggs can then be gently rolled on a NITEX® screen and culled (see Section 6, Test Organisms).

11.6.15.2.4 Natural Spawning

11.6.15.2.4.1 Cultures of adult fish to be used for spawning are maintained at 18-20°C until embryos are required. When embryos are required, raise the temperature to 25°C in the morning, seven or eight days before the beginning of a test. That afternoon, transfer the adult fish (generally, at least five females and three males) to a spawning chamber (approximately, 20 x 35 x 22 cm high; USEPA, 1978), which is a basket constructed of 3-5 mm NITEX® mesh, made to fit a 57-L (15 gal) aquarium. Spawning generally will begin within 24 h or less. Embryos will fall through the bottom of the basket and onto a collecting screen (250-500 μm mesh) or tray below the basket. Allow the embryos to collect for 24 h. Embryos are washed from the screen, checked for viability, and placed in incubation dishes. Replace the screens until a sufficient number of embryos have been collected. One-to-three spawning aquaria can be used to collect the required number of embryos to run a toxicity test. To help keep the embryos clean, the adults are fed while the screens are removed.

11.6.15.2.5 Incubation

11.6.15.2.5.1 Four hours post-fertilization, the embryos obtained by natural or forced spawning are rolled gently with a finger on a 250-500 μm Nitex® screen to remove excess fibers and tissue. The embryos have adhesive threads and tend to adhere to each other. Gentle rolling on the screen facilitates the culling process described below. To reduce fungal contamination of the newly spawned embryos after they have been manipulated, they should be placed in a 250 μm sieve and briskly sprayed with seawater from a squeeze bottle.

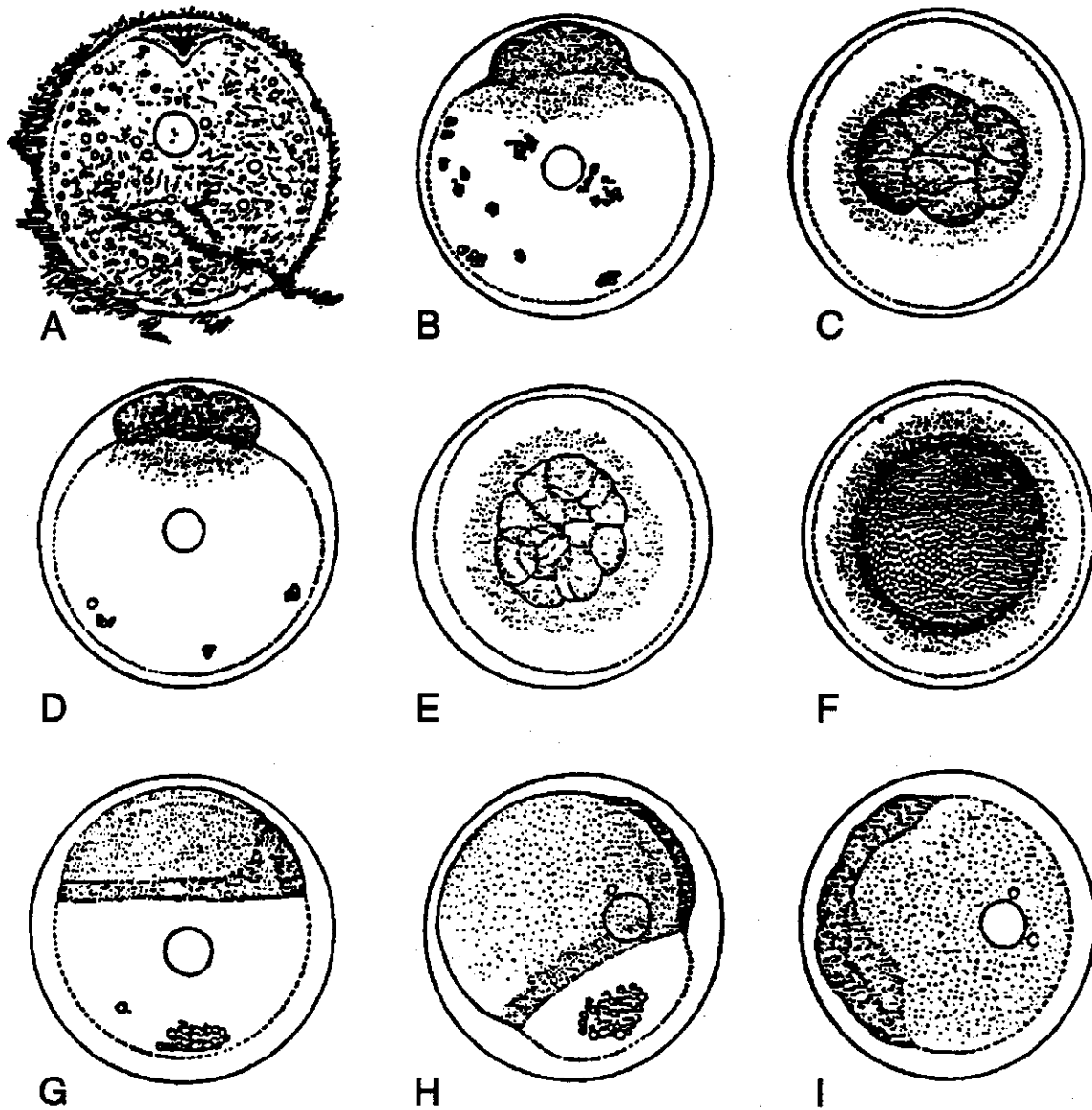

Figure 1. Embryonic development of sheephead minnow, *Cyprinodon variegatus*: A. Mature unfertilized egg, showing attachment filaments and micropyle, X33; B. Blastodisc fully developed; C,D. Blastodisc, 8 cells; E. Blastoderm, 16 cells; F. Blastoderm, late cleavage stage; G. Blastoderm with germ ring formed, embryonic shield developing; H. Blastoderm covers over 3/4 of yolk, yolk noticeably constricted; I. Early embryo. From Kuntz (1916).

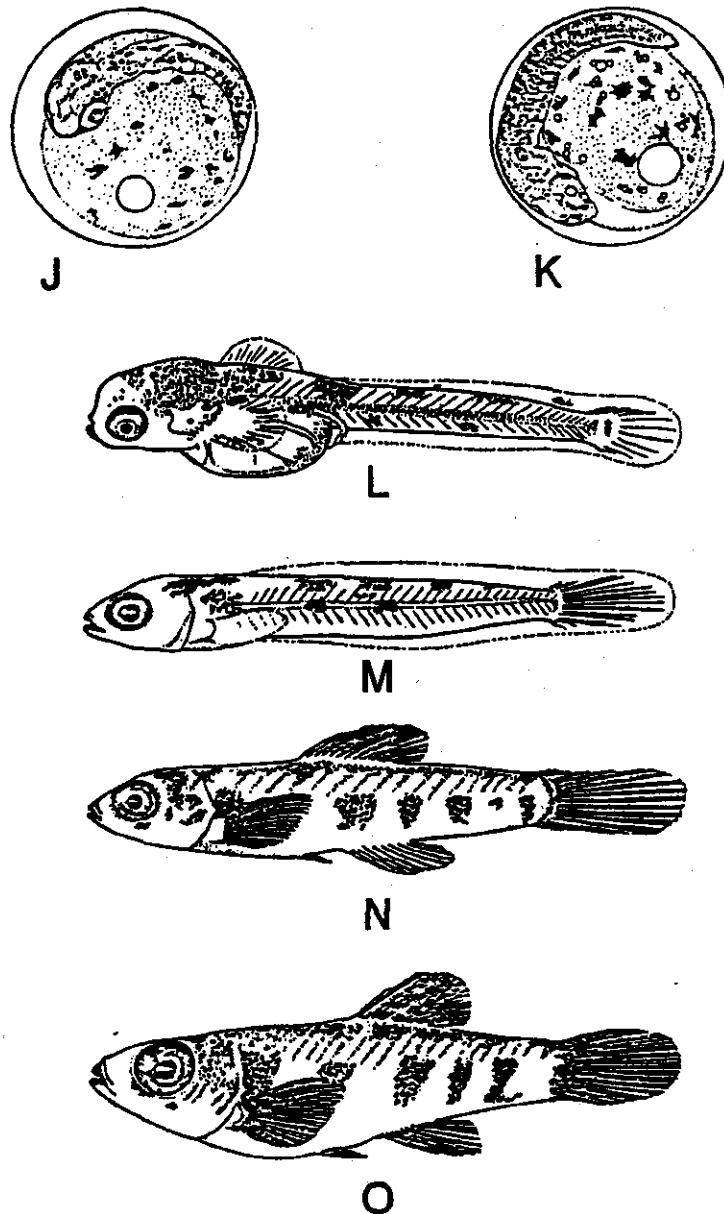

Figure 1. Embryonic development of sheephead minnow, *Cyprinodon variegatus*: J. Embryo 48 h after fertilization, now segmented throughout, pigment on yolk sac and body, otoliths formed; K. Posterior portion of embryo free from yolk and moves freely within egg membrane, 72 h after fertilization; L. Newly hatched fish, actual length 4 mm; M. Larval fish 5 days after hatching, actual length 5 mm; N. Young fish 9 mm in length; O. Young fish 12 mm in length (CONTINUED). From Kuntz (1916).

11.6.15.2.5.2 Under a dissecting microscope, separate and discard abnormal embryos and unfertilized eggs. While they are checked, the embryos are maintained in seawater at 25°C. The embryos should be in Stages C-G, Figure 1.

11.6.15.2.5.3 If the test is prepared with four replicates of 15 larvae at each of six treatments (five effluent concentrations and a control), and the combined mortality of eggs and larvae prior to the start of the test is less than 20%, approximately 400 viable embryos are required at this stage.

11.6.15.2.5.4 Embryos are demersal. They should be aerated and incubated at 25°C, at a salinity of 20-30‰ and a 16-h photoperiod. The embryos can be cultured in either a flow-through or static system, using aquaria or crystallization dishes. However, if the embryos are cultured in dishes, it is essential that aeration and daily water changes be provided, and the dishes be covered to reduce evaporation that may cause increased salinity. One-half to three-quarters of the seawater from the culture vessels can be poured off and the incubating embryos retained. Embryos cultured in this manner should hatch in six or seven days.

11.6.15.2.5.5 At 48 h post-fertilization, embryos are examined under a microscope to determine development and survival. Embryos should be in Stages I and J, Figure 1. Discard dead embryos. Approximately 360 viable embryos are required at this stage.

11.7 EFFLUENT AND RECEIVING WATER COLLECTION, PRESERVATION, AND STORAGE

11.7.1 See Section 8, Effluent and Receiving Water Sampling, Sample Handling, and Sample Preparation for Toxicity Tests.

11.8 CALIBRATION AND STANDARDIZATION

11.8.1 See Section 4, Quality Assurance.

11.9 QUALITY CONTROL

11.9.1 See Section 4, Quality Assurance.

11.10 TEST PROCEDURES

11.10.1 TEST SOLUTIONS

11.10.1.1 Receiving Waters

11.10.1.1.1 The sampling point is determined by the objectives of the test. At estuarine and marine sites, samples are usually collected at mid-depth. Receiving water toxicity is determined with samples used directly as collected or with samples passed through a 60 µm NITEX® filter and compared without dilution, against a control. Using four replicate chambers per test, each containing 500-750 mL, and 400 mL for chemical analysis, would require approximately 2.4-3.4 L or more of sample per test per day.

11.10.1.2 Effluents

11.10.1.2.1 The selection of the effluent test concentrations should be based on the objectives of the study. A dilution factor of 0.5 is commonly used. A dilution factor of 0.5 provides precision of $\pm 100\%$, and allows for testing of concentrations between 6.25% and 100% effluent using only five effluent concentrations (6.25%, 12.5%, 25.0%, 50.0%, and 100%). Test precision shows little improvement as dilution factors are increased beyond 0.5 and declines rapidly if smaller dilution factors are used. **Therefore, USEPA recommends the use of the ≥ 0.5 dilution factor.** If 100‰ HSB is used as a diluent, the maximum concentration of effluent that can be tested will be 80% at 20‰ salinity and 70% at 30‰ salinity.

11.10.1.2.2 If the effluent is known or suspected to be highly toxic, a lower range of effluent concentrations should be used (such as 25%, 12.5%, 6.25%, 3.12%, and 1.56%). If a high rate of mortality is observed during the first 1-to-2 h of the test, additional dilutions at the lower range of effluent concentrations should be added.

11.10.1.2.3 The volume of effluent required to initiate the test and for daily renewal of four replicates (minimum of three) per concentration for five concentrations of effluent and a control, each containing 750 mL of test solution, is approximately 5 L. Prepare enough test solution (approximately 3400 mL) at each effluent concentration to provide 400 mL additional volume for chemical analyses (Table 2).

11.10.1.2.4 The salinity of effluent and receiving water tests for sheepshead minnows should be between 20‰ and 30‰. If concurrent effluent and receiving water testing occurs, the effluent test salinity should closely approximate that of the receiving water test. If an effluent is tested alone, select a salinity between 20‰ and 30‰, whichever comes closest to the salinity of the receiving waters. Table 2 illustrates the quantities of effluent, artificial sea salts, hypersaline brine, or seawater needed to prepare 3 L of test solution at each treatment level for tests performed at 20‰ salinity.

11.10.1.2.5 Just prior to test initiation (approximately 1 h), the temperature of sufficient quantity of the sample to make the test solutions should be adjusted to the test temperature ($25 \pm 1^\circ\text{C}$) and maintained at that temperature during the addition of dilution water.

11.10.1.2.6 Higher effluent concentrations (i.e., 25%, 50%, and 100%) may require aeration to maintain adequate dissolved oxygen concentrations. However, if one solution is aerated, all concentrations must be aerated. Aerate effluent as it warms and continue to gently aerate test solutions in the test chambers for the duration of the test.

11.10.1.2.7 Effluent dilutions should be prepared for all replicates in each treatment in one beaker to minimize variability among the replicates. The test chambers are labelled with the test concentration and replicate number. Dispense into the appropriate effluent dilution chamber.

TABLE 2. PREPARATION OF TEST SOLUTIONS AT A SALINITY OF 20‰, USING 20‰ SALINITY DILUTION WATER PREPARED FROM NATURAL SEAWATER, HYPERSALINE BRINE, OR ARTIFICIAL SEA SALTS

Effluent Solution	Effluent Conc. (%)	Solutions To Be Combined	
		Volume of Effluent Solution	Volume of Diluent Seawater (20‰)
1	100 ^{1,2}	6800 mL	----
2	50	3400 mL Solution 1	+ 3400 mL
3	25	3400 mL Solution 2	+ 3400 mL
4	12.5	3400 mL Solution 3	+ 3400 mL
5	6.25	3400 mL Solution 4	+ 3400 mL
Control	0.0		3400 mL
Total			17000 mL

¹ This illustration assumes: (1) the use of 750 mL of test solution in each of four replicates and 400 mL for chemical analysis (total of 3,400 mL) for the control and each of five concentrations of effluent (2) an effluent dilution factor of 0.5, and (3) the effluent lacks appreciable salinity. A sufficient initial volume (6,800 mL) of effluent is prepared by adjusting the salinity to the desired level. In this example, the salinity is adjusted by adding artificial sea salts to the 100% effluent, and preparing a serial dilution using 20‰ seawater (natural seawater, hypersaline brine, or artificial seawater). Following addition of salts, the effluent is stirred for 1 h to ensure that the salts have dissolved. The salinity of the initial 6,800 mL of 100% effluent is adjusted to 20‰ by adding 136 g of dry artificial sea salts (FORTY FATHOMS®). Test concentrations are then made by mixing appropriate volumes of salinity-adjusted effluent and 20‰ salinity dilution water to provide 6,800 mL of solution for each concentration. If hypersaline brine alone (100‰) is used to adjust the salinity of the effluent, the highest concentration of effluent that could be achieved would be 80% at 20‰ salinity. When dry sea salts are used to adjust the salinity of the effluent, it may be desirable to use a salinity control prepared under the same conditions and used to determine survival and growth.

² The same procedures would be followed in preparing test concentrations at other salinities between 20‰ and 30‰: (1) the salinity of the bulk (initial) effluent sample would be adjusted to the appropriate salinity using artificial sea salts or hypersaline brine, and (2) the remaining effluent concentrations would be prepared by serial dilution, using a large batch (17,000 mL) of seawater for dilution water, which had been prepared at the same salinity as the effluent, using natural seawater, or hypersaline or artificial sea salts and deionized water.

11.10.1.3 Dilution Water

11.10.1.3.1 Dilution water may be uncontaminated natural seawater (receiving water), HSB prepared from natural seawater, or artificial seawater prepared from FORTY FATHOMS® or GP2 sea salts (see Table 1 and Section 7, Dilution Water). Other artificial sea salts may be used for culturing sheepshead minnows and for the larval survival and growth test if the control criteria for acceptability of test data are satisfied.

11.10.2 START OF THE TEST

11.10.2.1 Tests should begin as soon as possible, preferably within 24 h after sample collection. The maximum holding time following retrieval of the sample from the sampling device should not exceed 36 h for off-site toxicity tests unless permission is granted by the permitting authority. In no case should the sample be used in a test more than 72 h after sample collection (see Section 8, Effluent and Receiving Water Sampling, Sample Handling, and Sample Preparation for Toxicity Tests).

11.10.2.2 If the embryos have been incubating at 25°C, 30‰ salinity, and a 16-h photoperiod, for 5 to 6 days with aeration and daily water renewals, approximately 24 h prior to hatching, the salinity of the seawater in the incubation chamber may be reduced from 30‰ to the test salinity, if lower than 30‰. In addition to maintaining good water quality, reducing the salinity and/or changing the water may also help to initiate hatching over the next 24 h. A few larvae may hatch 24 h ahead of the majority. Remove these larvae and reserve them in a separate dish, maintaining the same culture conditions. It is preferable to use only the larvae that hatch in the 24 h prior to starting the test. However, if sufficient numbers of larvae do not hatch within the 24-h period, the larvae that hatch prior to 24 h are added to the test organisms. The test organisms are then randomly selected for the test. When eggs or larvae must be shipped to the test site from a remote location, it may be necessary to use larvae older than 24-h because of the difficulty in coordinating test organism shipments with field operations. However, in the latter case, the larvae should not be more than 48-h old at the start of the test and should all be within 24-h of the same age.

11.10.2.3 Label the test chambers with a marking pen. Use of color coded tape to identify each treatment and replicate. A minimum of five effluent concentrations and a control are used for each test. Each treatment (including controls) should have four (minimum of three) replicates. For exposure chambers, use 1000 mL beakers, non-toxic disposable plasticware, or glass chambers with a sump area as illustrated in the inland silverside test method (see Section 13).

11.10.2.4 Prepare the test solutions and add to the test chambers.

11.10.2.5 The test is started by randomly placing larvae from the common pool into each test chamber until each chamber contains 15 (minimum of 10) larvae, for a total of 60 larvae (minimum of 30) for each concentration (see Appendix A). The amount of water added to the chambers when transferring the larvae should be kept to a minimum to avoid unnecessary dilution of the test concentrations.

11.10.2.6 The chambers may be placed on a light table to facilitate counting the larvae.

11.10.2.7 Randomize the position of the test chambers at the beginning of the test (see Appendix A). Maintain the chambers in this configuration throughout the test. Preparation of a position chart may be helpful.

11.10.3 LIGHT, PHOTOPERIOD, SALINITY, AND TEMPERATURE

11.10.3.1 The light quality and intensity should be at ambient laboratory levels, which is approximately 10-20 $\mu\text{E}/\text{m}^2/\text{s}$, or 50 to 100 foot candles (ft-c), with a photoperiod of 16 h light and 8 h darkness. The water temperature in the test chambers should be maintained at $25 \pm 1^\circ\text{C}$. The test salinity should be in the range of 20 to 30‰ to accommodate receiving waters that may fall within this range. Conduct of this test at salinities less than 20‰ may cause an unacceptably low growth response and thereby invalidate the test. The salinity should vary by no more than $\pm 2\%$ among the chambers on a given day. If effluent and receiving water tests are conducted concurrently, the salinities of these tests should be similar.

11.10.4 DISSOLVED OXYGEN (DO) CONCENTRATION

11.10.4.1 Aeration may affect the toxicity of effluents and should be used only as a last resort to maintain a satisfactory DO. The DO should be measured on new solutions at the start of the test (Day 0) and before daily renewal of test solutions on subsequent days. The DO should not fall below 4.0 mg/L (see Section 8, Effluent and Receiving Water Sampling, Sample Handling, and Sample Preparation for Toxicity Tests). If it is necessary to aerate, all treatments and the control should be aerated. The aeration rate should not exceed 100 bubbles/min, using a pipet with a 1-2 mm orifice, such as a 1-mL KIMAX[®] serological pipet No. 37033, or equivalent. Care should be taken to ensure that turbulence resulting from aeration does not cause undue stress on the fish.

11.10.5 FEEDING

11.10.5.1 *Artemia* nauplii are prepared as described above.

11.10.5.2 Sheepshead minnow larvae are fed newly-hatched (less than 24-h old) *Artemia* nauplii once a day from hatch day 0 through day 6; larvae are not fed on day 7. Feed 0.10 g nauplii per test chamber on days 0-2, and 0.15 g nauplii per test chamber on days 3-6. Equal amounts of *Artemia* nauplii must be added to each replicate test chamber to minimize the variability of larval weight. Sufficient numbers of nauplii should be fed to ensure that some remain alive overnight in the test chambers. An adequate but not excessive amount should be provided to each replicate on a daily basis. Feeding excessive amounts of nauplii will result in a depletion in DO to a lower than acceptable level (below 4.0 mg/L). Siphon as much of the uneaten *Artemia* nauplii as possible from each chamber daily to ensure that the larvae principally eat newly hatched nauplii.

11.10.5.3 On days 0-2, weigh 4 g wet weight or pipette 4 mL of concentrated, rinsed *Artemia* nauplii for a test with five treatments and a control. Resuspend the 4 g *Artemia* in 80 mL of natural or artificial seawater in a 100 mL beaker. Aerate or swirl *Artemia* to maintain a thoroughly mixed suspension of nauplii. Dispense 2 mL *Artemia* suspension by pipette or adjustable syringe to each test chamber. Collect only enough *Artemia* in the pipette or syringe for one test chamber or settling of *Artemia* may occur, resulting in unequal amounts of *Artemia* being distributed to the replicate test chambers.

11.10.5.4 On days 3-6, weigh 6 g wet weight or pipette 6 mL *Artemia* suspension for a test with five treatments and a control. Resuspend the 6 g *Artemia* in 80 mL of natural or artificial seawater in a 100 mL beaker. Aerate or swirl as 2 mL is dispensed to each test chamber.

11.10.5.5 If the survival rate in any test replicate on any day falls below 50%, reduce the volume of *Artemia* added to that test chamber by one-half (i.e., from 2 mL to 1 mL) and continue feeding one-half the volume through day 6. Record the time of feeding on data sheets (Figure 2).

11.10.6 DAILY CLEANING OF TEST CHAMBERS

11.10.6.1 Before the daily renewal of test solutions, uneaten and dead *Artemia*, dead fish larvae, and other debris are removed from the bottom of the test chambers with a siphon hose. As much of the uneaten *Artemia* as possible should be siphoned from each chamber to ensure that the larvae principally eat newly hatched nauplii. Alternately, a large pipet (50 mL), fitted with a safety pipet filler or rubber bulb, can be used. Because of their small size during the first few days of the tests, larvae are easily drawn into the siphon tube when cleaning the test chambers. By placing the test chambers on a light box, inadvertent removal of live larvae can be greatly reduced because they can be more easily seen. If the water siphoned from the test chambers is collected in a white plastic tray, the live larvae caught in the siphon can be retrieved and returned to the appropriate test chamber. Any incidence of removal of live larvae from the test chambers by the siphon during cleaning, and subsequent return to the chambers, should be noted in the test records.

11.10.7 OBSERVATIONS DURING THE TEST

11.10.7.1 Routine Chemical and Physical Determinations

11.10.7.1.1 DO is measured at the beginning and end of each 24-h exposure period in one test chamber at each test concentration and in the control.

11.10.7.1.2 Temperature, pH, and salinity are measured at the end of each 24-h exposure period in one test chamber at each test concentration and in the control. Temperature should also be monitored continuously, observed and recorded daily for at least two locations in the environmental control system or the samples. Temperature should be measured in a sufficient number of test vessels at least at the end of the test to determine the temperature variation in the environmental chamber.

11.10.7.1.3 The pH is measured in the effluent sample each day.

11.10.7.1.4 Record all the measurements on the data sheet (Figure 2).

11.10.7.2 Routine Biological Observations

11.10.7.2.1 The number of live larvae in each test chamber are recorded daily (Figure 7), and the dead larvae are discarded.

11.10.7.2.2 Protect the larvae from unnecessary disturbance during the test by carrying out the daily test observations, solution renewals, and removal of dead larvae, carefully. Make sure the larvae remain immersed during the performance of the above operations.

11.10.8 TEST SOLUTION RENEWAL

11.10.8.1 The test solutions are renewed daily using freshly prepared solution, immediately after cleaning the test chambers. For on-site toxicity studies, fresh effluent and receiving water samples used in toxicity tests should be collected daily, and no more than 24 h should elapse between collection of the sample and use in the test (see Section 8, Effluent and Receiving Water Sampling, Sample Handling, and Sample Preparation for Toxicity Tests). For off-site tests, a minimum of three samples must be collected, preferably on days one, three, and five. Maintain the samples at 4°C until used.

11.10.8.2 For test solution renewal, the water level in each chamber is lowered to a depth of 7 to 10 mm, which leaves 15 to 20% of the test solution. New test solution (750 mL) should be added slowly by pouring down the side of the test chamber to avoid excessive turbulence and possible injury to the larvae.

11.10.9 TERMINATION OF THE TEST

11.10.9.1 The test is terminated after 7-d of exposure. At test termination, dead larvae are removed and discarded. The surviving larvae in each test chamber (replicate) are counted and immediately prepared as a group for dry weight determination, or are preserved as a group in 4% formalin or 70% ethanol. Preserved organisms are dried and weighed within 7 days. For safety, formalin should be used under a hood.

11.10.9.2 For immediate drying and weighing, siphon or pour live larvae onto a 500 μm mesh screen in a large beaker to retain the larvae and allow *Artemia* and debris to be rinsed away. Rinse the larvae with deionized water to wash away salts that might contribute to the dry weight. Sacrifice the larvae in an ice bath of deionized water.

11.10.9.3 Small aluminum weighing pans can be used to dry and weigh the larvae. Mark for identification an appropriate number of small aluminum weighing pans (one per replicate). Weigh to the nearest 0.01 mg, and record the weights (Figure 3).

11.10.9.4 Immediately prior to drying, rinse the preserved larvae in distilled water. The rinsed larvae from each test chamber is transferred to a tared weighing pan and dried at 60°C for 24 h or at 105°C for a minimum of 6 h. Immediately upon removal from the drying oven, the weighing pans are placed in a desiccator until weighed, to prevent the absorption of moisture from the air. Weigh to the nearest 0.01 mg all weighing pans containing dried larvae and subtract the tare weight to determine the dry weight of larvae in each replicate. Record the weights (Figure 3). For each test chamber, divide the final dry weight by the number of original larvae in the test chamber to determine the average individual dry weight, and record (Figure 3). For the controls, also calculate the mean weight per surviving fish in the test chamber to evaluate if weights met test acceptable criteria (see Section 12). Complete the summary data sheet (Figure 4) after calculating the average measurements and statistically analyzing the dry weights and percent survival. Average dry weights should be expressed to the nearest 0.001 mg.

11.11 SUMMARY OF TEST CONDITIONS AND TEST ACCEPTABILITY CRITERIA

11.11.1 A summary of test conditions and test acceptability criteria is listed in Table 3.

11.12 ACCEPTABILITY OF TEST RESULTS

11.12.1 The tests are acceptable if (1) the average survival of control larvae equals or exceeds 80%, and (2) the average dry weight per surviving unpreserved control larvae is equal to or greater than 0.60 mg, or (3) the average dry weight per surviving preserved control larvae is equal to or greater than 0.50 mg. The above minimum weights presume that the age of the larvae at the start of the test is less than or equal to 24 h.

11.13 DATA ANALYSIS

11.13.1 GENERAL

11.13.1.1 Tabulate and summarize the data. A sample set of survival and growth response data is listed in Table 4.

11.13.1.2 The endpoints of toxicity tests using the sheepshead minnow larvae are based on the adverse effects on survival and growth. The LC50, the IC25, and the IC50 are calculated using point estimation techniques (see Section 9, Chronic Toxicity Test Endpoints and Data Analysis). LOEC and NOEC values, for survival and growth, are obtained using a hypothesis testing approach such as Dunnett's Procedure (Dunnett, 1955) or Steel's Many-one Rank Test (Steel, 1959; Miller, 1981)(see Section 9). Separate analyses are performed for the estimation of the LOEC and NOEC endpoints and for the estimation of the LC50, IC25 and IC50. Concentrations at which there is no survival in any of the test chambers are excluded from the statistical analysis of the NOEC and LOEC for survival and growth, but included in the estimation of the LC50, IC25 and IC50. See the Appendices for examples of the manual computations, program listings, and examples of data input and program output.

Test Dates: _____ Species: _____

Effluent Tested: _____

TREATMENT						
NO. LIVE LARVAE						
SURVIVAL (%)						
MEAN DRY WT/ LARVAE (MG) ± SD						
SIGNIF. DIFF. FROM CONTROL (o)						
MEAN TEMPERATURE (°C) ± SD						
MEAN SALINITY ‰ ± SD						
AVE DISSOLVED OXYGEN (MG/L) ± SD						

COMMENTS:

Figure 4. Data form for the sheepshead minnow, *Cyprinodon variegatus*, larval survival and growth test. Summary of test results (from USEPA, 1987b).

TABLE 3. SUMMARY OF TEST CONDITIONS AND TEST ACCEPTABILITY CRITERIA FOR THE SHEEPSHEAD MINNOW, *CYPRINODON VARIEGATUS*, LARVAL SURVIVAL AND GROWTH TEST WITH EFFLUENTS AND RECEIVING WATERS

1. Test type:	Static renewal
2. Salinity:	20‰ to 32‰ (\pm 2‰ of the selected test salinity)
3. Temperature:	25 \pm 1°C
4. Light quality:	Ambient laboratory illumination
5. Light intensity:	10-20 μ E/m ² /s (50-100 ft-c) (ambient laboratory levels)
6. Photoperiod:	16 h light, 8 h darkness
7. Test chamber size:	600 mL - 1 L beakers or equivalent
8. Test solution volume:	500-750 mL/replicate (loading and DO restrictions must be met)
9. Renewal of test solutions:	Daily
10. Age of test organisms:	Newly hatched larvae (less than 24 h old; 24-h range in age)
11. No. larvae per test chamber:	15 (minimum of 10)
12. No. replicate chambers per concentration:	4 (minimum of 3)
13. No. larvae per concentration:	60 (minimum of 30)
14. Source of food:	Newly hatched <i>Artemia</i> nauplii, (less than 24-h old)
15. Feeding regime:	Feed once a day 0.10 g wet weight <i>Artemia</i> nauplii per replicate on Days 0-2; Feed 0.15 g wet weight <i>Artemia</i> nauplii per replicate on Days 3-6
16. Cleaning:	Siphon daily, immediately before test solution renewal and feeding
17. Aeration:	None, unless DO falls below 4.0 mg/L, then aerate all chambers. Rate should be less than 100 bubbles/min

TABLE 3. SUMMARY OF TEST CONDITIONS AND TEST ACCEPTABILITY CRITERIA FOR THE SHEEPSHEAD MINNOW, *CYPRINODON VARIEGATUS*, LARVAL SURVIVAL AND GROWTH TEST WITH EFFLUENTS AND RECEIVING WATERS (CONTINUED)

18. Dilution water:	Uncontaminated source of natural seawater; deionized water mixed with hypersaline brine or artificial sea salts (HW Marinemix®, FORTY FATHOMS®, GP2 or equivalent)
19. Test concentrations:	Effluent: Minimum of 5 and a control
20. Dilution factor:	Effluents: ≥ 0.5 Receiving waters: None, or ≥ 0.5
21. Test duration:	7 days
22. Endpoints:	Survival and growth (weight)
23. Test acceptability criteria:	80% or greater survival in controls; average dry weight per surviving organism in control chambers should be 0.60 mg or greater, if unpreserved, <u>or</u> 0.50 mg or greater after no more than 7 days in 4% formalin or 70% ethanol
24. Sampling requirements:	For on-site tests, samples collected daily, and used within 24 h of the time they are removed from the sampling device. For off-site tests, a minimum of three samples are collected on days one, three, and five with a maximum holding time of 36 h before first use (See Section 8, Effluent and Receiving Water Sampling, Sample Handling, and Sample Preparation for Toxicity Tests, Subsection 8.5.4)
25. Sample volume required:	6 L per day

TABLE 4. SUMMARY OF SURVIVAL AND GROWTH DATA FOR SHEEPSHEAD MINNOW, *CYPRINODON VARIEGATUS*, LARVAE EXPOSED TO AN EFFLUENT FOR SEVEN DAYS¹

Effl. Conc. (%)	Proportion of Survival in Replicate Chambers				Mean Prop. Surv	Avg Dry Wgt (mg) In Replicate Chambers				Mean Dry Wgt (mg)
	A	B	C	D		A	B	C	D	
0.0	1.0	1.0	1.0	1.0	1.00	1.29	1.32	1.59	1.27	1.368
6.25	1.0	1.0	0.9	1.0	0.98	1.27	1.00	0.97	0.97	1.053
12.5	1.0	1.0	1.0	1.0	1.00	1.32	1.37	1.35	1.34	1.345
25.0	1.0	1.0	1.0	0.8	0.95	1.29	1.33	1.20	0.94	1.190
50.0	0.8	0.8	0.7	0.6	0.73	0.62	0.56	0.46	0.46	0.525
100.0	0.0	0.0	0.0	0.0	0.00	--	--	--	--	--

¹ Four replicates of 10 larvae each.

11.13.1.3 The statistical tests described here must be used with a knowledge of the assumptions upon which the tests are contingent. Tests for normality and homogeneity of variance are included in Appendix B. The assistance of a statistician is recommended for analysts who are not proficient in statistics.

11.13.2 EXAMPLE OF ANALYSIS OF SHEEPSHEAD MINNOW, *CYPRINODON VARIEGATUS* SURVIVAL DATA

11.13.2.1 Formal statistical analysis of the survival data is outlined in Figures 5 and 6. The response used in the analysis is the proportion of animals surviving in each test or control chamber. Separate analyses are performed for the estimation of the NOEC and LOEC endpoints and for the estimation of the LC50 endpoint. Concentrations at which there is no survival in any of the test chambers are excluded from statistical analysis of the NOEC and LOEC, but included in the estimation of the IC, EC, and LC endpoint.

11.13.2.2 For the case of equal numbers of replicates across all concentrations and the control, the evaluation of the NOEC and LOEC endpoints is made via a parametric test, Dunnett's Procedure, or a nonparametric test, Steel's Many-one Rank Test, on the arc sine square root transformed data.

STATISTICAL ANALYSIS OF SHEEPSHEAD MINNOW LARVAL SURVIVAL AND GROWTH TEST

SURVIVAL HYPOTHESIS TESTING

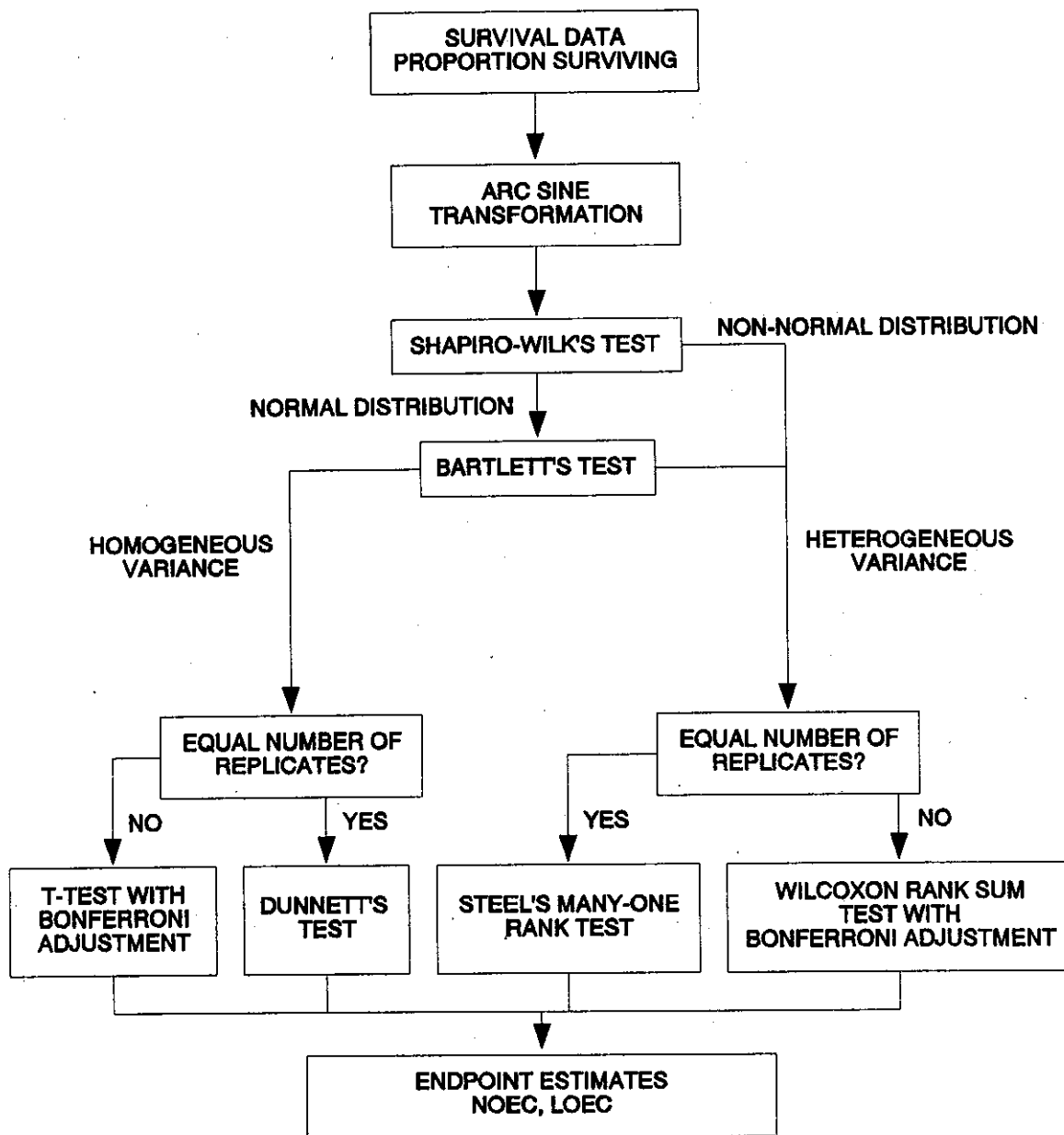

Figure 5. Flowchart for statistical analysis of the sheephead minnow, *Cyprinodon variegatus*, larval survival data by hypothesis testing.

STATISTICAL ANALYSIS OF SHEEPSHEAD MINNOW LARVAL SURVIVAL AND GROWTH TEST

SURVIVAL POINT ESTIMATION

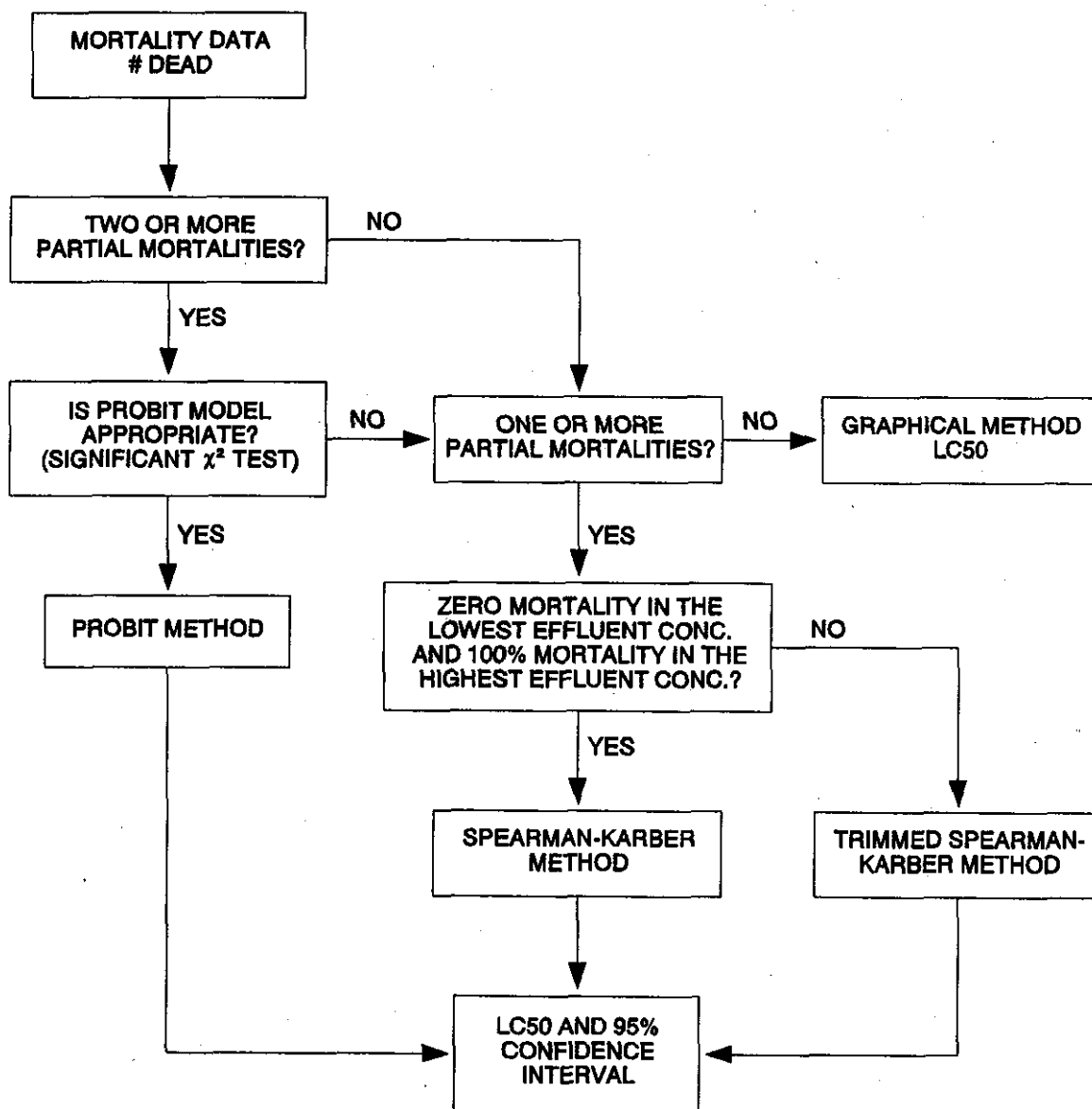

Figure 6. Flowchart for statistical analysis of the sheephead minnow, *Cyprinodon variegatus*, larval survival data by point estimation.

Underlying assumptions of Dunnett's Procedure, normality and homogeneity of variance, are formally tested. The test for normality is the Shapiro-Wilk's Test, and Bartlett's Test is used to test for homogeneity of variance. If either of these tests fails, the nonparametric test, Steel's Many-one Rank Test, is used to determine the NOEC and LOEC endpoints. If the assumptions of Dunnett's Procedure are met, the endpoints are estimated by the parametric procedure.

11.13.2.3 If unequal numbers of replicates occur among the concentration levels tested, there are parametric and nonparametric alternative analyses. The parametric analysis is a t-test with the Bonferroni adjustment (see Appendix D). The Wilcoxon Rank Sum Test with the Bonferroni adjustment is the nonparametric alternative.

11.13.2.4 Probit Analysis (Finney, 1971; see Appendix H) is used to estimate the concentration that causes a specified percent decrease in survival from the control. In this analysis, the total mortality data from all test replicates at a given concentration are combined. If the data do not fit the Probit Analysis, the Spearman-Kärber Method, the Trimmed Spearman-Kärber Method, or the Graphical Method may be used (see Appendices H-K).

11.13.2.5 Example of Analysis of Survival Data

11.13.2.5.1 This example uses the survival data from the Sheepshead Minnow Larval Survival and Growth Test. The proportion surviving in each replicate must first be transformed by the arc sine square root transformation procedure described in Appendix B. The raw and transformed data, means and variances of the transformed observations at each effluent concentration and control are listed in Table 5. A plot of the survival proportions is provided in Figure 7. Since there was 100% mortality in all four replicates for the 100% concentration, it was not included in the statistical analysis and was considered a qualitative mortality effect.

11.13.2.6 Test for Normality

11.13.2.6.1 The first step of the test for normality is to center the observations by subtracting the mean of all observations within a concentration from each observation in that concentration. The centered observations are summarized in Table 6.

11.13.2.6.2 Calculate the denominator, D, of the statistic:

$$D = \sum_{i=1}^n (X_i - \bar{X})^2$$

Where: X_i = the i th centered observation

\bar{X} = the overall mean of the centered observations

n = the total number of centered observations

TABLE 5. SHEEPSHEAD MINNOW, *CYPRINODON VARIEGATUS*, SURVIVAL DATA

	Replicate	Control	Effluent Concentration (%)			
			6.25	12.5	25.0	50.0
RAW	A	1.0	1.0	1.0	1.0	0.8
	B	1.0	1.0	1.0	1.0	0.8
	C	1.0	0.9	1.0	1.0	0.7
	D	1.0	1.0	1.0	0.8	0.6
ARC SINE TRANSFORMED	A	1.412	1.412	1.412	1.412	1.107
	B	1.412	1.412	1.412	1.412	1.107
	C	1.412	1.249	1.412	1.412	0.991
	D	1.412	1.412	1.412	1.107	0.886
Mean (\bar{Y}_i)		1.412	1.371	1.412	1.336	1.023
$S^2_{i^i}$		0.0	0.007	0.0	0.023	0.011
i^i		1	2	3	4	5

TABLE 6. CENTERED OBSERVATIONS FOR SHAPIRO-WILK'S EXAMPLE

Replicate	Control	Effluent Concentration (%)			
		6.25	12.5	25.0	50.0
A	0.0	0.041	0.0	0.076	0.084
B	0.0	0.041	0.0	0.076	0.084
C	0.0	-0.122	0.0	0.076	-0.032
D	0.0	0.041	0.0	-0.229	-0.137

11.13.2.6.3 For this set of data,

$$n = 20$$

$$\bar{X} = \frac{1}{20} (-0.001) = 0.000$$

$$D = 0.1236$$

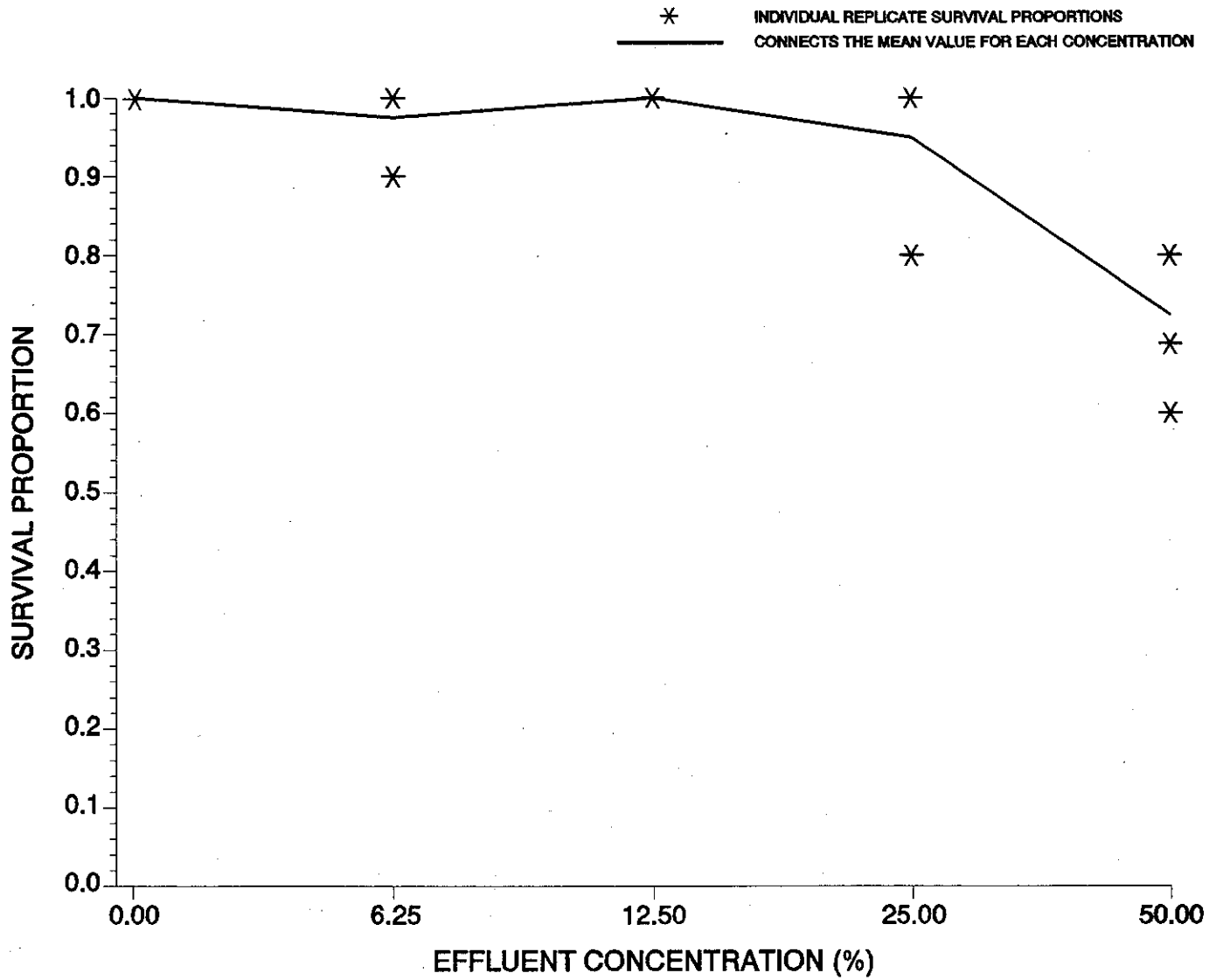

Figure 7. Plot of mean survival proportion data in Table 5.

11.13.2.6.4 Order the centered observations from smallest to largest

$$X^{(1)} \leq X^{(2)} \leq \dots \leq X^{(n)}$$

where $X^{(i)}$ denotes the i th ordered observation. The ordered observations for this example are listed in Table 7.

11.13.2.6.5 From Table 4, Appendix B, for the number of observations, n , obtain the coefficients a_1, a_2, \dots, a_k where k is $n/2$ if n is even and $(n-1)/2$ if n is odd. For the data in this example, $n = 20$ and $k = 10$. The a_i values are listed in Table 8.

11.13.2.6.6 Compute the test statistic, W , as follows:

$$W = \frac{1}{D} \left[\sum_{i=1}^k a_i (X^{(n-i+1)} - X^{(i)}) \right]^2$$

The differences $X^{(n-i+1)} - X^{(i)}$ are listed in Table 7. For the data in this example,

$$W = \frac{1}{0.1236} (0.3178)^2 = 0.8171$$

TABLE 7. ORDERED CENTERED OBSERVATIONS FOR THE SHAPIRO-WILK'S EXAMPLE

i	$X^{(i)}$	i	$X^{(i)}$
1	-0.229	11	0.0
2	-0.137	12	0.0
3	-0.122	13	0.041
4	-0.032	14	0.041
5	0.0	15	0.041
6	0.0	16	0.076
7	0.0	17	0.076
8	0.0	18	0.076
9	0.0	19	0.084
10	0.0	20	0.084

11.13.2.6.7 The decision rule for this test is to compare W as calculated in Subsection 11.13.2.6.6 to a critical value found in Table 6, Appendix B. If the computed W is less than the critical value, conclude that the data are not normally distributed. For the data in this example, the critical value at a significance level of 0.01 and $n = 20$ observations is 0.868. Since $W = 0.817$ is less than the critical value, conclude that the data are not normally distributed.

TABLE 8. COEFFICIENTS AND DIFFERENCES FOR SHAPIRO-WILK'S EXAMPLE

i	a_i	$\chi^{(n-i+1)} - \chi^{(i)}$	
1	0.4734	0.313	$\chi^{(20)} - \chi^{(1)}$
2	0.3211	0.221	$\chi^{(19)} - \chi^{(2)}$
3	0.2565	0.198	$\chi^{(18)} - \chi^{(3)}$
4	0.2085	0.108	$\chi^{(17)} - \chi^{(4)}$
5	0.1686	0.076	$\chi^{(16)} - \chi^{(5)}$
6	0.1334	0.041	$\chi^{(15)} - \chi^{(6)}$
7	0.1013	0.041	$\chi^{(14)} - \chi^{(7)}$
8	0.0711	0.041	$\chi^{(13)} - \chi^{(8)}$
9	0.0422	0.0	$\chi^{(12)} - \chi^{(9)}$
10	0.0140	0.0	$\chi^{(11)} - \chi^{(10)}$

11.13.2.6.8 Since the data do not meet the assumption of normality, Steel's Many-one Rank Test will be used to analyze the survival data.

11.13.2.7 Steel's Many-one Rank Test

11.13.2.7.1 For each control and concentration combination, combine the data and arrange the observations in order of size from smallest to largest. Assign the ranks (1, 2, ..., 8) to the ordered observations with a rank of 1 assigned to the smallest observation, rank of 2 assigned to the next larger observation, etc. If ties occur when ranking, assign the average rank to each tied observation.

11.13.2.7.2 An example of assigning ranks to the combined data for the control and 6.25% effluent concentration is given in Table 9. This ranking procedure is repeated for each control/concentration combination. The complete set of rankings is summarized in Table 10. The ranks are next summed for each effluent concentration, as shown in Table 11.

TABLE 9. ASSIGNING RANKS TO THE CONTROL AND 6.25% EFFLUENT CONCENTRATION FOR STEEL'S MANY-ONE RANK TEST

Rank	Transformed Proportion Surviving	Effluent Concentration (%)
1	1.249	6.25
5	1.412	6.25
5	1.412	6.25
5	1.412	6.25
5	1.412	Control
5	1.412	Control
5	1.412	Control
5	1.412	Control

TABLE 10. TABLE OF RANKS

Repli- cate	Control	Effluent Concentration (%)			
		6.25	12.5	25.0	50.0
A	1.412 (5,4.5,5,6.5)	1.412 (5)	1.412 (4.5)	1.412 (5)	1.107 (3.5)
B	1.412 (5,4.5,5,6.5)	1.412 (5)	1.412 (4.5)	1.412 (5)	1.107 (3.5)
C	1.412 (5,4.5,5,6.5)	1.249 (1)	1.412 (4.5)	1.412 (5)	0.991 (2)
D	1.412 (5,4.5,5,6.5)	1.412 (5)	1.412 (4.5)	1.107 (1)	0.886 (1)

TABLE 11. RANK SUMS

Effluent Concentration (%)	Rank Sum
6.25	16
12.5	18
25.0	16
50.0	10

11.13.2.7.3 For this example, determine if the survival in any of the effluent concentrations is significantly lower than the survival in the control. If this occurs, the rank sum at that concentration would be significantly lower than the rank sum of the control. Thus, compare the rank sums for the survival at each of the various effluent concentrations with some "minimum" or critical rank sum, at or below which the survival would be considered significantly lower than the control. At a significance level of 0.05, the minimum rank sum in a test with four concentrations (excluding the control) and four replicates is 10 (see Table 5, Appendix E).

11.13.2.7.4 Since the rank sum for the 50% effluent concentration is equal to the critical value, the proportion surviving in the 50% concentration is considered significantly less than that in the control. Since no other rank sums are less than or equal to the critical value, no other concentrations have a significantly lower proportion surviving than the control. Hence, the NOEC and the LOEC are the 25% and 50% concentrations, respectively.

11.13.2.8 Calculation of the LC50

11.13.2.8.1 The data used for the calculation of the LC50 is summarized in Table 12. For estimating the LC50, the data for the 100% effluent concentration with 100% mortality is included.

11.13.2.8.2 Because there are at least two partial mortalities in this set of test data, calculation of the LC50 using Probit Analysis is recommended. For this set of data, however, the test for heterogeneity of variance was significant. Probit Analysis is not appropriate in this case. Inspection of the data reveals that, once the data is smoothed and adjusted, the proportion mortality in the lowest effluent concentration will not be zero although the proportion mortality in the highest effluent concentration will be one. Therefore, the Spearman-Kärber Method is appropriate for this data.

11.13.2.8.3 Before the LC50 can be calculated the data must be smoothed and adjusted. For the data in this example, because the observed proportion mortality for the 12.5% effluent concentration is less than the observed response proportion for the 6.25% effluent concentration, the observed responses for the control and these two groups must be averaged:

$$p_0^s = p_1^s = p_2^s = \frac{0.00 + 0.025 + 0.00}{3} = \frac{0.025}{3} = 0.0083$$

Where: p_i^s = the smoothed observed mortality proportion for effluent concentration i .

11.13.2.8.3.1 Because the rest of the responses are monotonic, additional smoothing is not necessary. The smoothed observed proportion mortalities are shown in Table 12.

11.13.2.8.4 Because the smoothed observed proportion mortality for the control is now greater than zero, the data in each effluent concentration must

be adjusted using Abbott's formula (Finney, 1971). The adjustment takes the form:

Where: p_0^s = the smoothed observed proportion mortality for the control

$$p_i^a = (p_i^s - p_0^s) / (1 - p_0^s)$$

p_i^s = the smoothed observed proportion mortality for effluent concentration i

11.13.2.8.4.1 For the data in this example, the data for each effluent concentration must be adjusted for control mortality using Abbott's formula, as follows:

$$p_0^a = p_1^a = p_2^a = \frac{p_1^s - p_0^s}{1 - p_0^s} = \frac{0.0083 - 0.0083}{1 - 0.0083} = \frac{0.00}{0.9917} = 0.0$$

$$p_3^a = \frac{p_3^s - p_0^s}{1 - p_0^s} = \frac{0.05 - 0.0083}{1 - 0.0083} = \frac{0.0417}{0.9917} = 0.042$$

$$p_4^a = \frac{p_4^s - p_0^s}{1 - p_0^s} = \frac{0.275 - 0.0083}{1 - 0.0083} = \frac{0.2667}{0.9917} = 0.269$$

$$p_5^a = \frac{p_5^s - p_0^s}{1 - p_0^s} = \frac{1.000 - 0.0083}{1 - 0.0083} = \frac{0.9917}{0.9917} = 1.000$$

The smoothed, adjusted response proportions for the effluent concentrations are shown in Table 12.

TABLE 12. DATA FOR EXAMPLE OF SPEARMAN-KARBER ANALYSIS

Effluent Concentration %	Number of Deaths	Number of Organisms Exposed	Mortality Proportion	Smoothed Mortality Proportion	Smoothed, Adjusted Mortality Proportion
Control	0	40	0.000	0.0083	0.000
6.25	1	40	0.025	0.0083	0.000
12.5	0	40	0.000	0.0083	0.000
25.0	2	40	0.050	0.0500	0.042
50.0	11	40	0.275	0.2750	0.269
100.0	40	40	1.000	1.0000	1.000

11.13.2.8.5 Calculate the \log_{10} of the estimated LC50, m , as follows:

$$m = \sum_{i=1}^{k-1} \frac{(p_{i+1}^a) (X_i + X_{i+1})}{2}$$

Where: p_i^a = the smoothed adjusted proportion mortality at concentration i

X_i = the \log_{10} of concentration i

k = the number of effluent concentrations tested, not including the control

11.13.2.8.5.1 For this example, the \log_{10} of the estimated LC50, m , is calculated as follows:

$$\begin{aligned} m &= [(0.000 - 0.000) (0.7959 + 1.0969)]/2 + \\ & [(0.042 - 0.000) (1.0969 + 1.3979)]/2 + \\ & [(0.269 - 0.042) (1.3979 + 1.6990)]/2 + \\ & [(1.000 - 0.269) (1.6990 + 2.0000)]/2 \\ &= 1.755873 \end{aligned}$$

11.13.2.8.6 Calculate the estimated variance of m as follows:

$$V(m) = \sum_{i=2}^{k-1} \frac{p_i^a (1-p_i^a) (X_{i+1} + X_{i-1})^2}{4(n_i - 1)}$$

Where: X_i = the \log_{10} of concentration i

n_i = the number of organisms tested at effluent concentration i

p_i^a = the smoothed adjusted observed proportion mortality at effluent concentration i

k = the number of effluent concentrations tested, not including the control

11.13.2.8.6.1 For this example, the estimated variance of m , $V(m)$, is calculated as follows:

$$\begin{aligned} V(m) &= (0.000)(1.000)(1.3979 - 0.7959)^2/4(39) + \\ & (0.042)(0.958)(1.6990 - 1.0969)^2/4(39) + \\ & (0.269)(0.731)(2.0000 - 1.3979)^2/4(39) \\ &= 0.0005505 \end{aligned}$$

11.13.2.8.7 Calculate the 95% confidence interval for m : $m \pm 2.0 \sqrt{V(m)}$

11.13.2.8.7.1 For this example, the 95% confidence interval for m is calculated as follows:

$$1.755873 \pm 2 \sqrt{0.0005505} = (1.754772, 1.756974)$$

11.13.2.8.8 The estimated LC50 and a 95% confidence interval for the estimated LC50 can be found by taking base₁₀ antilogs of the above values.

11.13.2.8.8.1 For this example, the estimated LC50 is calculated as follows:

$$\text{LC50} = \text{antilog}(m) = \text{antilog}(1.755873) = 57.0\%.$$

11.13.2.8.8.2 The limits of the 95% confidence interval for the estimated LC50 are calculated by taking the antilogs of the upper and lower limits of the 95% confidence interval for m as follows:

$$\text{lower limit: } \text{antilog}(1.754772) = 56.9\%$$

$$\text{upper limit: } \text{antilog}(1.756974) = 57.1\%$$

11.13.3 EXAMPLE OF ANALYSIS OF SHEEPSHEAD MINNOW, *CYPRINODON VARIEGATUS*, GROWTH DATA

11.13.3.1 Formal statistical analysis of the growth data is outlined in Figure 8. The response used in the statistical analysis is mean weight per original organism for each replicate. The IC25 and IC50 can be calculated for the growth data via a point estimation technique (see Section 9, Chronic Toxicity Test Endpoints and Data Analysis). Hypothesis testing can be used to obtain an NOEC and LOEC for growth. Concentrations above the NOEC for survival are excluded from the hypothesis test for growth effects.

11.13.3.2 The statistical analysis using hypothesis testing consists of a parametric test, Dunnett's Procedure, and a nonparametric test, Steel's Many-one Rank Test. The underlying assumptions of the Dunnett's Procedure, normality and homogeneity of variance, are formally tested. The test for normality is the Shapiro-Wilk's Test and Bartlett's Test is used to test for homogeneity of variance. If either of these tests fails, the nonparametric test, Steel's Many-one Rank Test, is used to determine the NOEC and LOEC endpoints. If the assumptions of Dunnett's Procedure are met, the endpoints are determined by the parametric test.

11.13.3.3 Additionally, if unequal numbers of replicates occur among the concentration levels tested there are parametric and nonparametric alternative analyses. The parametric analysis is a t test with the Bonferroni adjustment. The Wilcoxon Rank Sum Test with the Bonferroni adjustment is the nonparametric alternative. For detailed information on the Bonferroni adjustment, see Appendix D.

11.13.3.4 The data, mean and variance of the observations at each concentration including the control are listed in Table 13. A plot of the mean weights for each treatment is provided in Figure 9. Since there is no

STATISTICAL ANALYSIS OF SHEEPSHEAD MINNOW LARVAL SURVIVAL AND GROWTH TEST

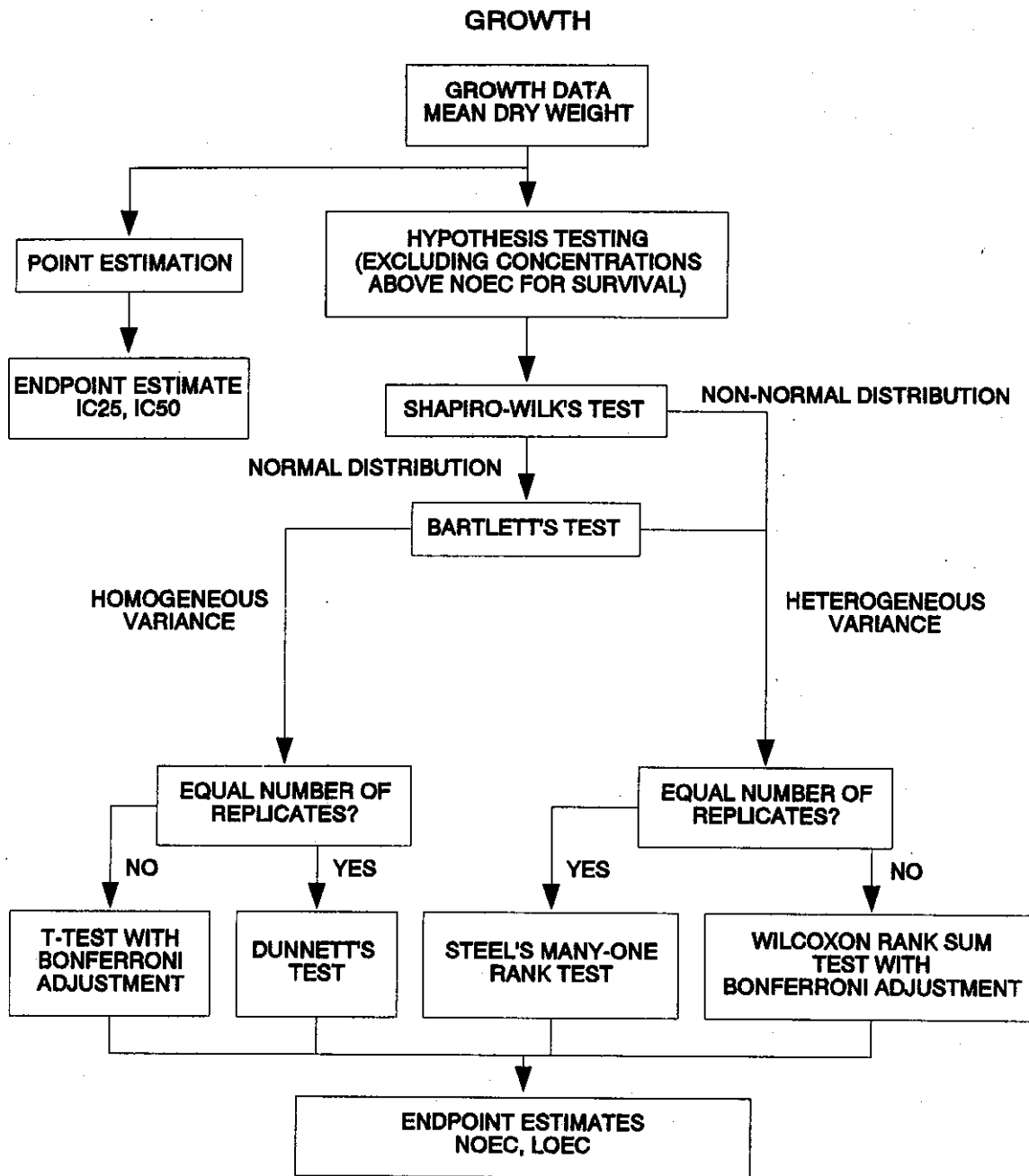

Figure 8. Flowchart for statistical analysis of the sheephead minnow, *Cyprinodon variegatus*, larval growth data.

survival in the 100% concentration, it is not considered in the growth analysis. Additionally, since there is significant mortality in the 50% effluent concentration, its effect on growth is not considered.

TABLE 13. SHEEPSHEAD MINNOW, *CYPRINODON VARIEGATUS*, GROWTH DATA

Replicate	Control	Effluent Concentration (%)				
		6.25	12.5	25.0	50.0	100.0
A	1.29	1.27	1.32	1.29	-	-
B	1.32	1.00	1.37	1.33	-	-
C	1.59	0.97	1.35	1.20	-	-
D	1.27	0.97	1.34	0.94	-	-
Mean(\bar{Y}_i)	1.368	1.053	1.345	1.190	-	-
S_i^2	0.0224	0.0212	0.0004	0.0307	-	-
i	1	2	3	4	5	6

11.13.3.5 Test for Normality

11.13.3.5.1 The first step of the test for normality is to center the observations by subtracting the mean of all the observations within a concentration from each observation in that concentration. The centered observations are summarized in Table 14.

TABLE 14. CENTERED OBSERVATIONS FOR SHAPIRO-WILK'S EXAMPLE

Replicate	Control	Effluent Concentration (%)		
		6.25	12.5	25.0
A	-0.078	0.217	-0.025	0.100
B	-0.048	-0.053	0.025	0.140
C	0.222	-0.083	0.005	0.010
D	-0.098	0.083	-0.005	-0.250

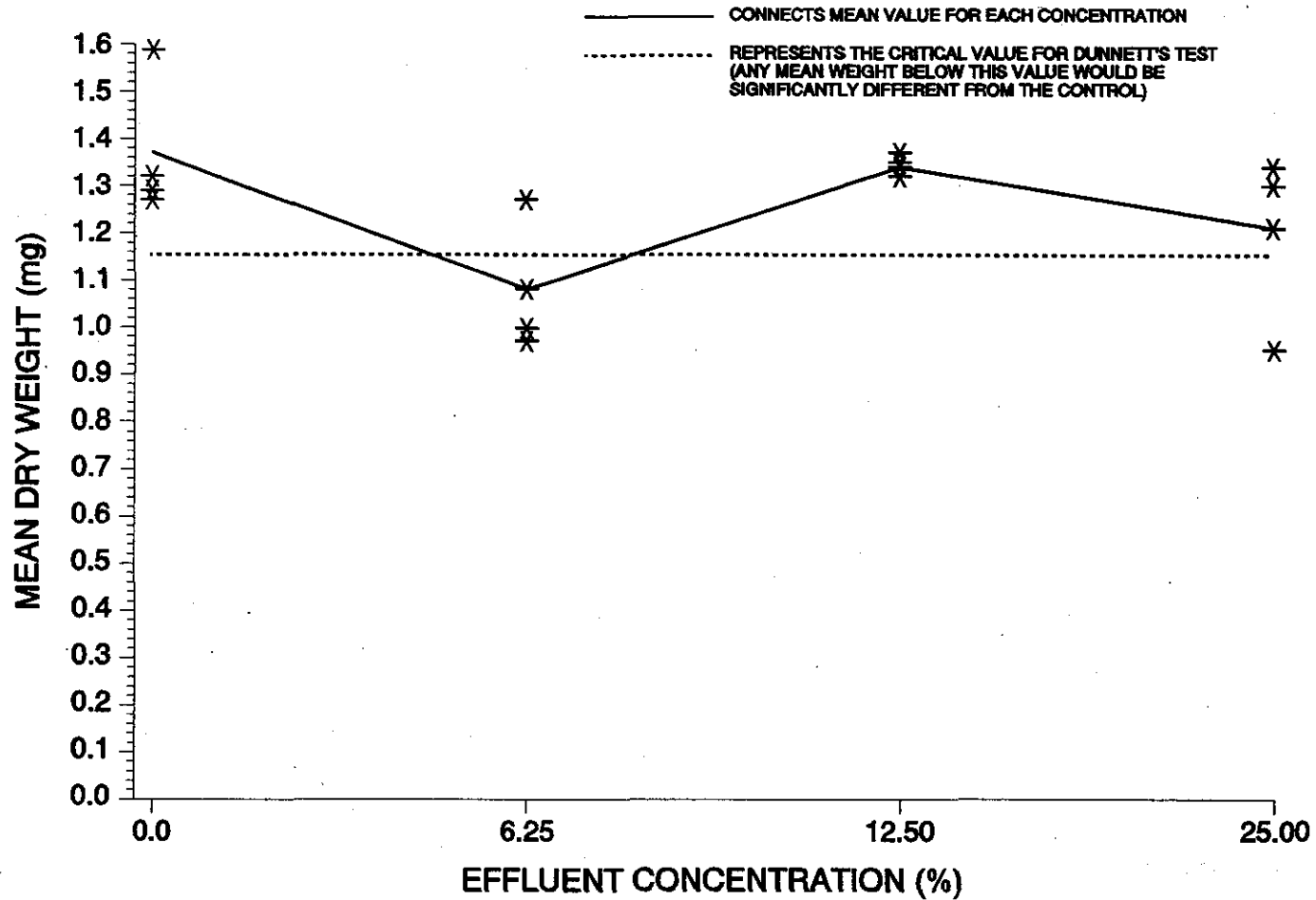

Figure 9. Plot of weight data from sheephead minnow, *Cyprinodon variegatus*, larval survival and growth test.

11.13.3.5.2 Calculate the denominator, D, of the test statistic:

$$D = \sum_{i=1}^n (X_i - \bar{X})^2$$

Where: X_i = the i th centered observation

\bar{X} = the overall mean of the centered observations

n = the total number of centered observations.

For this set of data, $n = 16$

$$\bar{X} = \frac{1}{16}(-0.004) = -0.00025 = 0.00$$

$$D = 0.2245$$

11.13.3.5.3 Order the centered observations from smallest to largest:

$$X^{(1)} \leq X^{(2)} \leq \dots \leq X^{(n)}$$

Where $X^{(i)}$ is the i th ordered observation. These ordered observations are listed in Table 15.

TABLE 15. ORDERED CENTERED OBSERVATIONS FOR SHAPIRO-WILK'S EXAMPLE

i	$X^{(i)}$	i	$X^{(i)}$
1	-0.250	9	-0.005
2	-0.098	10	0.005
3	-0.083	11	0.010
4	-0.083	12	0.025
5	-0.078	13	0.100
6	-0.053	14	0.140
7	-0.048	15	0.217
8	-0.025	16	0.222

11.13.3.5.4 From Table 4, Appendix B, for the number of observations, n , obtain the coefficients a_1, a_2, \dots, a_k where k is $n/2$ if n is even and $(n-1)/2$ if n is odd. For the data in this example, $n = 16$ and $k = 8$. The a_i values are listed in Table 16.

TABLE 16. COEFFICIENTS AND DIFFERENCES FOR SHAPIRO-WILK'S EXAMPLE

i	a_i	$X^{(n-i+1)} - X^{(i)}$	
1	0.5056	0.472	$X^{(16)} - X^{(1)}$
2	0.3290	0.315	$X^{(15)} - X^{(2)}$
3	0.2521	0.223	$X^{(14)} - X^{(3)}$
4	0.1939	0.183	$X^{(13)} - X^{(4)}$
5	0.1447	0.103	$X^{(12)} - X^{(5)}$
6	0.1005	0.063	$X^{(11)} - X^{(6)}$
7	0.0593	0.053	$X^{(10)} - X^{(7)}$
8	0.0196	0.020	$X^{(9)} - X^{(8)}$

11.13.3.5.5 Compute the test statistic, W , as follows:

$$W = \frac{1}{D} \left[\sum_{i=1}^k a_i (X^{(n-i+1)} - X^{(i)}) \right]^2$$

The differences $X^{(n-i+1)} - X^{(i)}$ are listed in Table 16.

For this set of data:

$$W = \frac{1}{0.2245} (0.4588)^2 = 0.938$$

11.13.3.5.6 The decision rule for this test is to compare W with the critical value found in Table 6, Appendix B. If the computed W is less than the critical value, conclude that the data are not normally distributed. For this example, the critical value at a significance level of 0.01 and 16 observations (n) is 0.876. Since $W = 0.938$ is greater than the critical value, the conclusion of the test is that the data are normally distributed.

11.13.3.6 Test for Homogeneity of Variance

11.13.3.6.1 The test used to examine whether the variation in mean dry weight is the same across all effluent concentrations including the control, is

Bartlett's Test (Snedecor and Cochran, 1980). The test statistic is as follows:

$$B = \frac{[(\sum_{i=1}^p V_i) \ln \bar{S}^2 - \sum_{i=1}^p V_i \ln S_i^2]}{C}$$

- Where: V_i = degrees of freedom for each effluent concentration and control, $V_i = (n_i - 1)$
 n_i = the number of replicates for concentration i
 p = number of levels of effluent concentration including the control
 \ln = \log_e
 i = 1, 2, ..., p where p is the number of concentrations including the control

$$\bar{S}^2 = \frac{(\sum_{i=1}^p V_i S_i^2)}{\sum_{i=1}^p V_i}$$

$$C = 1 + [3(p-1)]^{-1} [\sum_{i=1}^p 1/V_i - (\sum_{i=1}^p V_i)^{-1}]$$

11.13.3.6.2 For the data in this example (see Table 14), all effluent concentrations including the control have the same number of replicates ($n_i = 4$ for all i). Thus, $V_i = 3$ for all i .

11.13.3.6.3 Bartlett's statistic is therefore:

$$\begin{aligned} B &= [(12) \ln(0.0137) - 3 \sum_{i=1}^p \ln(S_i^2)] / 1.139 \\ &= [12(-4.290) - 3(-18.960)] / 1.139 \\ &= 5.396 / 1.139 \\ &= 4.737 \end{aligned}$$

11.13.3.6.4 B is approximately distributed as chi-square with $p - 1$ degrees of freedom, when the variances are in fact the same. Therefore, the appropriate critical value for this test, at a significance level of 0.01 with three degrees of freedom, is 11.345. Since $B = 4.737$ is less than the critical value of 11.345, conclude that the variances are not different.

11.13.3.7 Dunnett's Procedure

11.13.3.7.1 To obtain an estimate of the pooled variance for the Dunnett's Procedure, construct an ANOVA table as described in Table 17.

TABLE 17. ANOVA TABLE

Source	df	Sum of Squares (SS)	Mean Square (MS) (SS/df)
Between	$p - 1$	SSB	$S_B^2 = SSB/(p-1)$
Within	$N - p$	SSW	$S_W^2 = SSW/(N-p)$
Total	$N - 1$	SST	

Where: p = number of concentration levels including the control

N = total number of observations $n_1 + n_2 \dots + n_p$

n_i = number of observations in concentration i

$$SSB = \sum_{i=1}^p T_i^2/n_i - G^2/N \quad \text{Between Sum of Squares}$$

$$SST = \sum_{i=1}^p \sum_{j=1}^{n_i} Y_{ij}^2 - G^2/N \quad \text{Total Sum of Squares}$$

$$SSW = SST - SSB \quad \text{Within Sum of Squares}$$

G = the grand total of all sample observations, $G = \sum_{i=1}^p T_i$

T_i = the total of the replicate measurements for concentration i

Y_{ij} = the j th observation for concentration i (represents the mean dry weight of the mysids for concentration i in test chamber j)

11.13.3.7.2 For the data in this example:

$$n_1 = n_2 = n_3 = n_4 = 4$$

$$N = 16$$

$$T_1 = Y_{11} + Y_{12} + Y_{13} + Y_{14} = 5.47$$

$$T_2 = Y_{21} + Y_{22} + Y_{23} + Y_{24} = 4.21$$

$$T_3 = Y_{31} + Y_{32} + Y_{33} + Y_{34} = 5.38$$

$$T_4 = Y_{41} + Y_{42} + Y_{43} + Y_{44} = 4.76$$

$$G = T_1 + T_2 + T_3 + T_4 = 19.82$$

$$SSB = \sum_{i=1}^p T_i^2/n_i - G^2/N$$

$$= \frac{1}{4} (99.247) - \frac{(19.82)^2}{16} = 0.260$$

$$SST = \sum_{i=1}^p \sum_{j=1}^{n_i} Y_{ij}^2 - G^2/N$$

$$= 25.036 - \frac{(19.82)^2}{16} = 0.484$$

$$SSW = SST - SSB = 0.484 - 0.260 = 0.224$$

$$S_B^2 = SSB/(p-1) = 0.260/(4-1) = 0.087$$

$$S_W^2 = SSW/(N-p) = 0.224/(16-4) = 0.019$$

11.13.3.7.3 Summarize these calculations in the ANOVA table (Table 18).

TABLE 18. ANOVA TABLE FOR DUNNETT'S PROCEDURE EXAMPLE

Source	df	Sum of Squares (SS)	Mean Square (MS) (SS/df)
Between	3	0.260	0.087
Within	12	0.224	0.019
Total	15	0.484	

11.13.3.7.4 To perform the individual comparisons, calculate the t statistic for each concentration, and control combination as follows:

$$t_i = \frac{(Y_i - Y_1)}{S_w \sqrt{(1/n_1) + (1/n_i)}}$$

Where: Y_i = mean dry weight for effluent concentration i

Y_1 = mean dry weight for the control

S_w = square root of the within mean square

n_1 = number of replicates for the control

n_i = number of replicates for concentration i.

11.13.3.7.5 Table 19 includes the calculated t values for each concentration and control combination. In this example, comparing the 6.25% concentration with the control, the calculation is as follows:

TABLE 19. CALCULATED T VALUES

Effluent Concentration (%)	i	t_i
6.25	2	3.228
12.5	3	0.236
25.0	4	1.824

$$t_2 = \frac{(1.368 - 1.053)}{[0.138\sqrt{(1/4) + (1/4)}]} = 3.228$$

11.13.3.7.6 Since the purpose of this test is to detect a significant reduction in mean weight, a one-sided test is appropriate. The critical value for this one-sided test is found in Table 5, Appendix C. For an overall alpha level of 0.05, 12 degrees of freedom for error and three concentrations (excluding the control) the critical value is 2.29. The mean weight for concentration i is considered significantly less than the mean weight for the control if t_i is greater than the critical value. Since t_2 is greater than 2.29, the 6.25% concentration has significantly lower growth than the control. However, the 12.5% and 25% concentrations do not exhibit this effect. Hence the NOEC and the LOEC for growth cannot be calculated.

11.13.3.7.7 To quantify the sensitivity of the test, the minimum significant difference (MSD) that can be statistically detected may be calculated:

$$MSD = d S_w \sqrt{(1/n_1) + (1/n)}$$

Where: d = the critical value for Dunnett's Procedure

S_w = the square root of the within mean square

n = the common number of replicates at each concentration
(this assumes equal replication at each concentration)

n_1 = the number of replicates in the control.

11.13.3.7.8 In this example:

$$\begin{aligned} MSD &= 2.29 (0.10) \sqrt{(1/4) + (1/4)} \\ &= 2.29 (0.138) (0.707) \\ &= 0.223 \end{aligned}$$

11.13.3.7.9 Therefore, for this set of data, the minimum difference that can be detected as statistically significant is 0.223 mg.

11.13.3.7.10 This represents a 16% reduction in mean weight from the control.

11.13.3.8 Calculation of the ICp

11.13.3.8.1 The growth data from Table 4 are utilized in this example. As seen from Table 4 and Figure 7, the observed means are not monotonically non-increasing with respect to concentration (mean response for each higher concentration is not less than or equal to the mean response for the previous concentration and the responses between concentrations do not follow a linear trends). Therefore, the means are smoothed prior to calculating the IC. In the following discussion, the observed means are represented by \bar{Y}_i and the smoothed means by M_i .

11.13.3.8.2 Starting with the control mean, $\bar{Y}_1 = 1.368$ and $\bar{Y}_2 = 1.053$, we see that $\bar{Y}_1 > \bar{Y}_2$. Set $M_1 = \bar{Y}_1$. Comparing \bar{Y}_2 to \bar{Y}_3 , $\bar{Y}_2 < \bar{Y}_3$.

11.13.3.8.3 Calculate the smoothed means:

$$M_2 = M_3 = (\bar{Y}_2 + \bar{Y}_3)/2 = 1.199$$

11.13.3.8.4 Since $\bar{Y}_6 = 0 < \bar{Y}_5 = 0.525 < \bar{Y}_4 = 1.190 < \bar{Y}_4 = 1.345$, set $M_3 = 1.199$, $M_4 = 1.190$, $M_5 = 0.525$, and set $M_6 = 0$.

11.13.3.8.5 Table 20 contains the response means and smoothed means and Figure 10 gives a plot of the smoothed response curve.

TABLE 20. SHEEPSHEAD MINNOW, *CYPRINODON VARIEGATUS*, MEAN GROWTH RESPONSE AFTER SMOOTHING

Effluent Conc. (%)	i	Response Means (mg) \bar{Y}_i	Smoothed Means (mg) M_i
Control	1	1.368	1.368
6.25	2	1.053	1.199
12.50	3	1.345	1.199
25.00	4	1.189	1.189
50.00	5	0.525	0.525
100.00	6	0.0	0.0

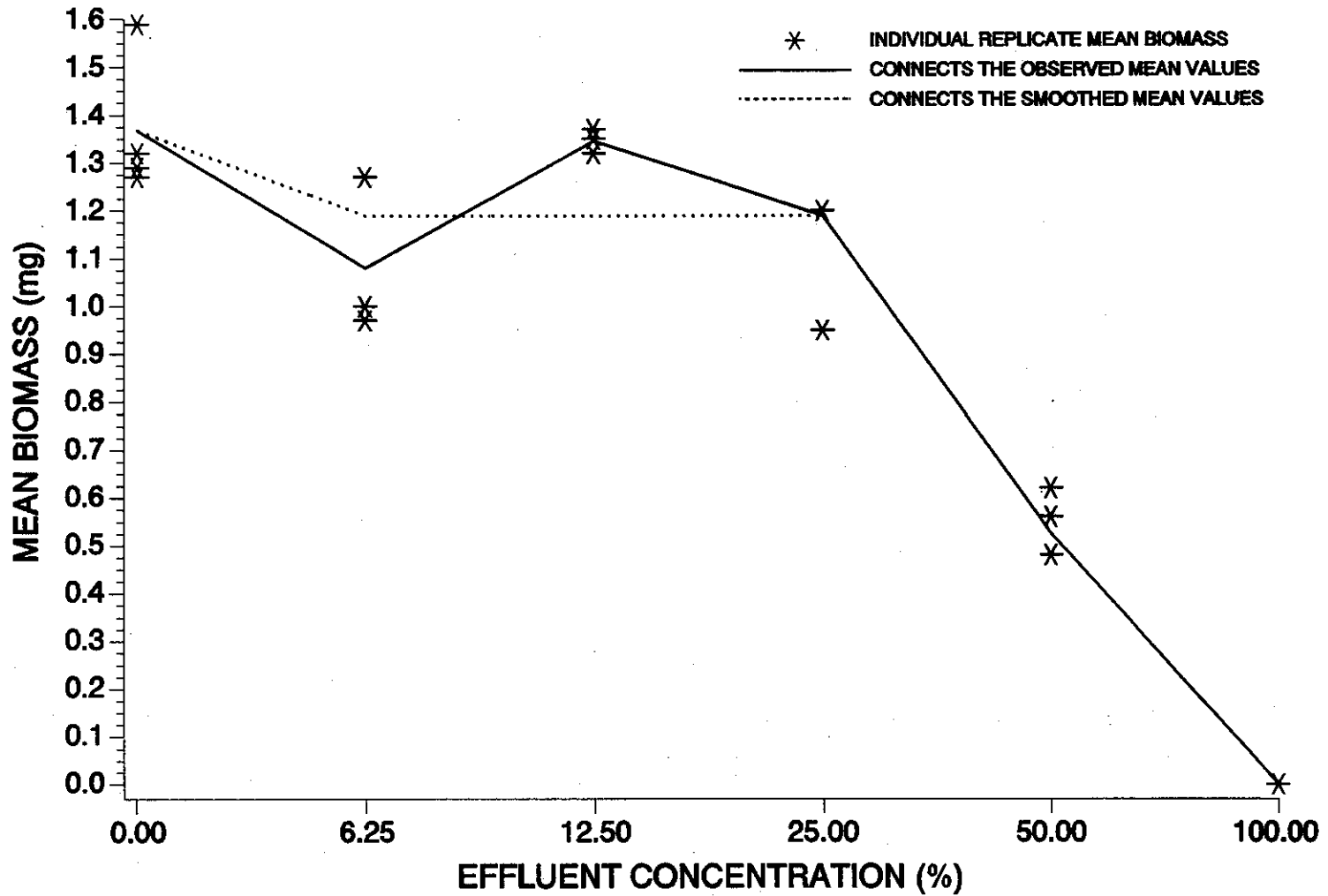

Figure 10. Plot of raw data, observed means, and smoothed means for the sheephead minnow, *Cyprinodon variegatus*, growth data from Tables 4 and 21.

11.13.3.8.6 An IC25 and IC50 can be estimated using the Linear Interpolation Method. A 25% reduction in weight, compared to the controls, would result in a mean dry weight of 1.026 mg, where $M_j(1-p/100) = 1.368(1-25/100)$. A 50% reduction in mean dry weight, compared to the controls, would result in a mean dry weight of 0.684 mg. Examining the smoothed means and their associated concentrations (Table 4), the response, 1.026 mg, is bracketed by $C_4 = 25.0\%$ effluent and $C_5 = 50.0\%$ effluent. The response (0.684 mg) is bracketed by $C_4 = 25.0\%$ effluent and $C_5 = 50\%$ effluent.

11.13.3.8.7 Using the equation from Section 4.2 of Appendix M, the estimate of the IC25 is calculated as follows:

$$ICP = C_j + [M_1(1-p/100) - M_j] \frac{(C_{(j+1)} - C_j)}{(M_{(j+1)} - M_j)}$$

$$\begin{aligned} IC25 &= 25.0 + [1.368(1 - 25/100) - 1.189] \frac{(50.00 - 25.00)}{(0.525 - 1.189)} \\ &= 31.2\%. \end{aligned}$$

11.13.3.8.8 Using the equation from Section 4.2 of Appendix L, the estimate of the IC50 is calculated as follows:

$$ICP = C_j + [M_1(1-p/100) - M_j] \frac{(C_{(j+1)} - C_j)}{(M_{(j+1)} - M_j)}$$

$$\begin{aligned} IC50 &= 50.0 + [1.368(1-50/100) - 0.525] \frac{(100.00-50.00)}{(0.0 - 0.525)} \\ &= 44.0\%. \end{aligned}$$

11.13.3.8.9 When the ICPIN program was used to analyze this set of data, requesting 80 resamples, the estimate of the IC25 was 31.1512%. The empirical 95% confidence interval for the true mean was 22.0420% and 36.3613%. The computer program output for the IC25 for this data set is shown in Figure 11.

11.13.3.8.10 When the ICPIN program was used to analyze this set of data for the IC50, requesting 80 resamples, the estimate of the IC50 was 44.0230%. The empirical 95% confidence interval for the true mean was 39.1011% and 49.0679%. The computer program output is shown in Figure 12.

Conc. ID	1	2	3	4	5	6
Conc. Tested	0	6.25	12.5	25	50	100
Response 1	1.29	1.27	1.32	1.29	.62	0
Response 2	1.32	1	1.37	1.33	.560	0
Response 3	1.59	.972	1.35	1.2	.46	0
Response 4	1.27	.97	1.34	.936	.46	0

*** Inhibition Concentration Percentage Estimate ***

Toxicant/Effluent: Effluent

Test Start Date: Test Ending Date:

Test Species: *Cyprinodon variegatus*

Test Duration: 7-d

DATA FILE: sheep.icp

OUTPUT FILE: sheep.i25

Conc. ID	Number Replicates	Concentration %	Response Means	Std. Dev.	Pooled Response Means
1	4	0.000	1.368	0.150	1.368
2	4	6.250	1.053	0.145	1.199
3	4	12.500	1.345	0.021	1.199
4	4	25.000	1.189	0.177	1.189
5	4	50.000	0.525	0.079	0.525
6	4	100.000	0.000	0.000	0.000

The Linear Interpolation Estimate: 31.1512 Entered P Value: 25

Number of Resamplings: 80

The Bootstrap Estimates Mean: 30.6175 Standard Deviation: 2.9490

Original Confidence Limits: Lower: 25.4579 Upper: 34.4075

Expanded Confidence Limits: Lower: 22.0420 Upper: 36.3613

Resampling time in Seconds: 1.70 Random Seed: -2137496326

Figure 11. ICPIN program output for the IC25.

Conc. ID	1	2	3	4	5	6
Conc. Tested	0	6.25	12.5	25	50	100
Response 1	1.29	1.27	1.32	1.29	.62	0
Response 2	1.32	1	1.37	1.33	.560	0
Response 3	1.59	.972	1.35	1.2	.46	0
Response 4	1.27	.97	1.34	.936	.46	0

*** Inhibition Concentration Percentage Estimate ***

Toxicant/Effluent: Effluent

Test Start Date: Test Ending Date:

Test Species: Cyprinodon variegatus

Test Duration: 7-d

DATA FILE: sheep.icp

OUTPUT FILE: sheep.i50

Conc. ID	Number Replicates	Concentration %	Response Means	Std. Dev.	Pooled Response Means
1	4	0.000	1.368	0.150	1.368
2	4	6.250	1.053	0.145	1.199
3	4	12.500	1.345	0.021	1.199
4	4	25.000	1.189	0.177	1.189
5	4	50.000	0.525	0.079	0.525
6	4	100.000	0.000	0.000	0.000

The Linear Interpolation Estimate: 44.0230 Entered P Value: 50

Number of Resamplings: 80

The Bootstrap Estimates Mean: 44.3444 Standard Deviation: 1.7372

Original Confidence Limits: Lower: 40.9468 Upper: 47.1760

Expanded Confidence Limits: Lower: 39.1011 Upper: 49.0679

Resampling time in Seconds: 1.70 Random Seed: -156164614

Figure 12. ICPIN program output for the IC50.

11.14 PRECISION AND ACCURACY

11.14.1 PRECISION

11.14.1.1 Single-Laboratory Precision

11.14.1.1.1 Data on the single-laboratory precision of the sheepshead minnow larval survival and growth test using FORTY FATHOMS® artificial seawater, natural seawater, and GP2 with copper sulfate, sodium dodecyl sulfate, and hexavalent chromium, as reference toxicants, are given in Tables 21-27. The IC25, IC50, or LC50 data (coefficient of variation), indicating acceptable precision for the reference toxicants (copper, sodium dodecyl sulfate, and hexavalent chromium), are also listed in these Tables.

11.14.1.2 Multilaboratory Precision

11.14.1.2.1 Data from a study of multilaboratory test precision, involving a total of seven tests by four participating laboratories, are listed in Table 27. The laboratories reported very similar results, indicating good interlaboratory precision. The coefficient of variation (IC25) was 44.2% and (IC50) was 56.9%, indicating acceptable precision.

11.14.2 ACCURACY

11.14.2.1 The accuracy of toxicity tests cannot be determined.

TABLE 21. SINGLE-LABORATORY PRECISION OF THE SHEEPSHEAD MINNOW, *CYPRINODON VARIEGATUS*, LARVAL SURVIVAL AND GROWTH TEST PERFORMED IN FORTY FATHOMS® ARTIFICIAL SEAWATER, USING LARVAE FROM FISH MAINTAINED AND SPAWNED IN FORTY FATHOMS® ARTIFICIAL SEAWATER, USING COPPER (CU) SULFATE AS A REFERENCE TOXICANT^{1,2,3,4,5}

Test Number	NOEC (µg/L)	IC25 (µg/L)	IC50 (µg/L)	Most Sensitive Endpoint ⁶
1	50	113.3	152.3	S
2	< 50 ⁷	54.3	97.5	G
3	< 50 ⁷	41.8	71.4	G
4	50	63.2	90.8	S
5	< 50 ⁷	57.7	99.8	S
6	50	48.3	132.5	G
7	50	79.6	159.7	G
8	50	123.5	236.4	G
n:	5	8	8	
Mean:	NA	72.7	130.0	
CV(%):	NA	41.82	40.87	

- ¹ Data from USEPA (1988a) and USEPA (1991a).
- ² Tests performed by Donald J. Klemm, Bioassessment and Ecotoxicology Branch, EMSL, Cincinnati, OH.
- ³ All tests were performed using Forty Fathoms® synthetic seawater. Three replicate exposure chambers, each with 15 larvae, were used for the control and each copper concentration. Copper concentrations used in Tests 1-6 were: 50, 100, 200, 400, and 800 µg/L. Copper concentrations in Tests 7-8 were: 25, 50, 100, 200 and 400 µg/L.
- ⁴ Adults collected in the field.
- ⁵ For a discussion of the precision of data from chronic toxicity test see Section 4, Quality Assurance.
- ⁶ Endpoints: G=growth; S=survival.
- ⁷ Lowest concentration tested was 50 µg/L (NOEC Range: > 50* - 50 µg/L).

TABLE 22. SINGLE-LABORATORY PRECISION OF THE SHEEPSHEAD MINNOW, *CYPRINIDON VARIEGATUS*, LARVAL SURVIVAL AND GROWTH TEST PERFORMED IN FORTY FATHOMS® ARTIFICIAL SEAWATER, USING LARVAE FROM FISH MAINTAINED AND SPAWNED IN FORTY FATHOMS® ARTIFICIAL SEAWATER, USING SODIUM DODECYL SULFATE (SDS) AS A REFERENCE TOXICANT^{1,2,3,4,5,6}

Test Number	NOEC (mg/L)	IC25 (mg/L)	IC50 (mg/L)	Most Sensitive Endpoint ⁷
1	1.0	1.2799	1.5598	S
2	1.0	1.4087	1.8835	S
3	1.0	2.3051	2.8367	S
4	0.5	1.9855	2.6237	G
5	1.0	1.1901	1.4267	S
6	0.5	1.1041	1.4264	G
n:	6	6	6	
Mean:	NA	1.5456	1.9595	
CV(%):	NA	31.44	31.82	

¹ Data from USEPA (1988a) and USEPA (1991a).

² Tests performed by Donald J. Klemm, Bioassessment and Ecotoxicology Branch, EMSL, Cincinnati, OH.

³ All tests were performed using Forty Fathoms® synthetic seawater. Three replicate exposure chambers, each with 15 larvae, were used for the control and each SDS concentration. SDS concentrations in Tests 1-2 were: 1.0, 1.9, 3.9, 7.7, and 15.5 mg/L. SDS concentrations in Tests 3-6 were: 0.2, 0.5, 1.0, 1.9, and 3.9 mg/L.

⁴ Adults collected in the field.

⁵ For a discussion of the precision of data from chronic toxicity tests see Section 4, Quality Assurance.

⁶ NOEC Range: 0.5 -1.0 mg/L (this represents a difference of one exposure concentration).

⁷ Endpoints: G=growth; S=survival

TABLE 23. SINGLE-LABORATORY PRECISION OF THE SHEEPSHEAD MINNOW, *CYPRINIDON VARIEGATUS*, LARVAL SURVIVAL AND GROWTH TEST PERFORMED IN NATURAL SEAWATER, USING LARVAE FROM FISH MAINTAINED AND SPAWNED IN NATURAL SEAWATER, USING COPPER (CU) SULFATE AS A REFERENCE TOXICANT^{1,2,3,4,5,6}

Test Number	NOEC (µg/L)	IC25 (µg/L)	IC50 (µg/L)	Most Sensitive Endpoint ⁷
1	125	320.3	437.5	S
2	31	182.3	323.0	G
3	125	333.4	484.4	S
4	125	228.4	343.8	S
5	125	437.5	NC ⁸	S
n:	5	5	4	
Mean:	NA	300.4	396.9	
CV(%):	NA	33.0	19.2	

- ¹ Data from USEPA (1988a) and USEPA (1991a).
- ² Tests performed by George Morrison and Elise Torello, ERL-N, USEPA, Narragansett, RI.
- ³ Three replicate exposure chambers, each with 10-15 larvae, were used for the control and each copper concentration. Copper concentrations were: 31, 63, 125, 250, and 500 µg/L.
- ⁴ NOEC Range: 31 - 125 µg/L (this represents a difference of two exposure concentrations).
- ⁵ Adults collected in the field.
- ⁶ For a discussion of the precision of data from chronic toxicity tests see Section 4, Quality Assurance.
- ⁷ Endpoints: G=growth; S=survival.
- ⁸ NC = No linear interpolation estimate could be calculated from the data, since none of the group response means were less than 50 percent of the control response mean.

TABLE 24. SINGLE-LABORATORY PRECISION OF THE SHEEPSHEAD MINNOW, *CYPRINIDON VARIEGATUS*, LARVAL SURVIVAL AND GROWTH TEST PERFORMED IN NATURAL SEAWATER, USING LARVAE FROM FISH MAINTAINED AND SPAWNED IN NATURAL SEAWATER, USING SODIUM DODECYL SULFATE (SDS) AS A REFERENCE TOXICANT^{1,2,3,4,5,6}

Test Number	NOEC (mg/L)	IC25 (mg/L)	IC50 (mg/L)	Most Sensitive Endpoint ⁷
1	2.5	2.9	3.6	S
2	1.3	NC1 ⁸	NC2 ⁹	G
3	1.3	1.9	2.4	S
4	1.3	2.4	NC2	G
5	1.3	1.5	1.8	S
n:	5	4	3	
Mean:	NA	2.2	2.6	
CV(%):	NA	27.6	35.3	

¹ Data from USEPA (1988a) and USEPA (1991a).

² Tests performed by George Morrison and Elise Torello, ERL-N, USEPA, Narragansett, RI.

³ Three replicate exposure chambers, each with 10-15 larvae, were used for the control and each SDS concentration. SDS concentrations were: 0.3, 0.6, 1.3, 2.5, and 5.0 mg/L.

⁴ NOEC Range: 1.3 - 2.5 mg/L (this represents a difference of one exposure concentration).

⁵ Adults collected in the field.

⁶ For a discussion of the precision of data from chronic toxicity tests see Section 4, Quality Assurance.

⁷ Endpoints: G=growth; S=survival.

⁸ NC1 = No linear interpolation estimate could be calculated from the data, since none of the group response means were less than 75 percent of the control response mean.

⁹ NC2 = No linear interpolation estimate could be calculated from the data, since none of the group response means were less than 50 percent of the control response mean.

TABLE 25. SINGLE-LABORATORY PRECISION OF THE SHEEPSHEAD MINNOW, *CYPRINODON VARIEGATUS*, LARVAL SURVIVAL AND GROWTH TEST PERFORMED IN FORTY FATHOMS® ARTIFICIAL SEAWATER, USING LARVAE FROM FISH MAINTAINED AND SPAWNED IN FORTY FATHOMS® ARTIFICIAL SEAWATER, AND HEXAVALENT CHROMIUM AS THE REFERENCE TOXICANT^{1,2,3,4,5}

Test Number	NOEC (mg/L)	IC25 (mg/L)	IC50 (mg/L)	Most Sensitive Endpoint ⁶
1	2.0	5.8	11.4	G
2	1.0	2.9	9.9	G
3	4.0	6.9	11.5	G
4	2.0	2.4	9.2	G
5	1.0	3.1	10.8	G
n:	5	5	5	
Mean:	NA	4.2	10.6	
CV(%):	NA	47.6	9.7	

¹ Tests performed by Donald Klemm, Bioassessment and Ecotoxicology Branch, EMSL, Cincinnati, OH.

² All tests were performed using Forty Fathoms® synthetic seawater. Three replicate exposure chambers, each with 15 larvae, were used for the control and each hexavalent chromium concentration. Hexavalent chromium concentrations used in Tests 1-5 were: 1.0, 2.0, 4.0, 8.0, 16.0, and 32.0 mg/L.

³ NOEC Range: 1.0 - 4.0 mg/L (this represents a difference of four exposure concentrations)

⁴ Adults collected in the field.

⁵ For a discussion of the precision of data from chronic toxicity tests see Section 4, Quality Assurance.

⁶ Endpoints: G=growth; S=survival.

TABLE 26. COMPARISON OF LARVAL SURVIVAL (LC50) AND GROWTH (IC50) VALUES FOR THE SHEEPSHEAD MINNOW, *CYPRINODON VARIEGATUS*, EXPOSED TO SODIUM DODECYL SULFATE (SDS) AND COPPER (CU) SULFATE IN GP2 ARTIFICIAL SEAWATER MEDIUM OR NATURAL SEAWATER^{1,2,3,4}

SDS (mg/L)	Survival		Growth	
	GP2	NSW	GP2	NSW
	7.49	8.13	7.39	8.41
	8.70	8.87	8.63	8.51
	8.38	8.85	8.48	9.33
Mean	8.19	8.62	8.17	8.75
CV (%)	7.7	4.9	8.3	5.8
COPPER (µg/L)	GP2	NSW	GP2	NSW
	455	412	341	333
	467	485	496	529
	390	528	467	776
Mean	437	475	435	546
CV (%)	9.4	12.3	18.9	40.7

¹ Tests performed by George Morrison and Glen Modica, ERL-N, USEPA, Narragansett, RI.

² Three replicate exposure chambers, each with 10-15 larvae, were used for the control and each SDS concentration. SDS concentrations were: 0.3, 0.6, 1.3, 2.5, and 5.0 mg/L.

³ Adults collected in the field.

⁴ For a discussion of the precision of data from chronic toxicity tests see Section 4, Quality Assurance.

TABLE 27. DATA FROM INTERLABORATORY STUDY OF THE SHEEPSHEAD MINNOW, *CYPRINODON VARIEGATUS*, LARVAL SURVIVAL AND GROWTH TEST USING AN INDUSTRIAL EFFLUENT AS A REFERENCE TOXICANT^{1,2,3}

	Test Number	Most Sensitive Endpoint ⁴		
		NOEC (%)	IC25 (%)	IC50 (%)
Laboratory A	1	3.2 (S,G)	7.4 (S)	7.4 (G)
	2	3.2 (S,G)	7.6 (S)	14.3 (G)
Laboratory B	1	3.2 (S,G)	5.7 (G)	9.7 (G)
	2	3.2 (S,G)	5.7 (G)	8.8 (G)
Laboratory C	1	1.0 (S)	4.7 (S)	7.2 (S)
Laboratory D	1	3.2 (S,G)	7.4 (G)	24.7 (G)
	2	1.0 (G)	5.2 (S)	7.2 (S)
n:		7	7	7
Mean:		NA	5.5	11.3
CV(%):		NA	44.2	56.9

¹ Data from USEPA (1987b), USEPA (1988a), and USEPA (1991a).

² Effluent concentrations were: 0.32, 1.0, 3.2, 10.0, and 32.0%.

³ NOEC Range: 1.0 - 3.2% (this represents a difference of one exposure concentration).

⁴ Endpoints: G=growth; S=survival.

SECTION 12

TEST METHOD

SHEEPSHEAD MINNOW, *CYPRINODON VARIEGATUS* EMBRYO-LARVAL SURVIVAL AND TERATOGENICITY TEST METHOD 1005.0

12.1 SCOPE AND APPLICATION

12.1.1 This method, adapted in part from USEPA (1981) and USEPA (1987b), estimates the chronic toxicity of effluents and receiving waters to the sheepshead minnow, *Cyprinodon variegatus*, using embryos and larvae in a nine-day, static renewal test. The effects include the synergistic, antagonistic, and additive effects of all the chemical, physical, and biological components which adversely affect the physiological and biochemical functions of the test organisms. The test is useful in screening for teratogens because organisms are exposed during embryonic development.

12.1.2 Daily observations on mortality make it possible to also calculate acute toxicity for desired exposure periods (i.e., 24-h, 48-h, 96-h LC50s).

12.1.3 Detection limits of the toxicity of an effluent or chemical substance are organism dependent.

12.1.4 Brief excursions in toxicity may not be detected using 24-h composite samples. Also, because of the long sample collection period involved in composite sampling, and because the test chambers are not sealed, highly volatile and highly degradable toxicants present in the source may not be detected in the test.

12.1.5 This test is commonly used in one of two forms: (1) a definitive test, consisting of a minimum of five effluent concentrations and a control, and (2) a receiving water test(s), consisting of one or more receiving water concentrations and a control.

12.2 SUMMARY OF METHOD

12.2.1 Sheepshead minnow, *Cyprinodon variegatus*, embryos and larvae are exposed in a static renewal system to different concentrations of effluent or to receiving water starting shortly after fertilization of the eggs through four days posthatch. Test results are based on the total frequency of both mortality and gross morphological deformities (terata).

12.3 INTERFERENCES

12.3.1 Toxic substances may be introduced by contaminants in dilution water, glassware, sample hardware, and testing equipment (see Section 5, Facilities, Equipment, and Supplies).

12.3.2 Adverse effects of low dissolved oxygen concentrations (DO), high concentrations of suspended and/or dissolved solids, and extremes of pH may mask the effect of toxic substances.

12.3.3 Improper effluent sampling and handling may adversely affect test results (see Section 8, Effluent and Receiving Water Sampling, Sample Handling, and Sample Preparation for Toxicity Tests).

12.3.4 Pathogenic and/or predatory organisms in the dilution water and effluent may affect test organism survival, and confound test results.

12.4 SAFETY

12.4.1 See Section 3, Health and Safety.

12.5 APPARATUS AND EQUIPMENT

12.5.1 Facilities for holding and acclimating test organisms.

12.5.2 Sheepshead minnow culture unit -- see Subsection 6.13 below. To perform toxicity tests on-site or in the laboratory, sufficient numbers of newly fertilized eggs must be available, preferably from an in-house sheepshead minnow culture unit. If necessary, embryos can be obtained from outside sources if shipped in well oxygenated water in insulated containers.

12.5.2.1 A test using 15 embryos per test vessel and four replicates per concentration, will require 360 newly-fertilized embryos at the start of the test. A test with a minimum of 10 embryos per test vessel and three replicates per concentration, and with five effluent concentrations and a control, will require a minimum of 180 embryos at the start of the test.

12.5.3 Brine shrimp, *Artemia*, culture unit -- for feeding sheepshead minnow larvae in the continuous culture unit (see Subsection 6.12 below).

12.5.4 Samplers -- automatic sampler, preferably with sample cooling capability, that can collect a 24-h composite sample of 5 L, and maintain sample temperature at 4°C.

12.5.5 Environmental chamber or equivalent facility with temperature control ($25 \pm 1^\circ\text{C}$).

12.5.6 Water purification system -- Millipore Milli-Q®, deionized water (DI) or equivalent.

12.5.7 Balance -- analytical, capable of accurately weighing to 0.00001 g.
Note: An analytical balance is not needed for this test but is needed for other specified toxicity test methods with growth endpoints.

12.5.8 Reference weights, Class S -- for checking the performance of the balance. The reference weights should bracket the expected weights of reagents, and the expected weights of the weighing pans and the weights of the weighing pans plus larvae.

- 12.5.9 Air pump -- for oil free air supply.
- 12.5.10 Air lines, and air stones -- for aerating water containing embryos, larvae, or supplying air to test solution with low DO.
- 12.5.11 Meters, pH and DO -- for routine physical and chemical measurements.
- 12.5.12 Standard or micro-Winkler apparatus -- for determining DO (optional).
- 12.5.13 Dissecting microscope -- for examining embryos and larvae.
- 12.5.14 Light box -- for counting and observing embryos and larvae.
- 12.5.15 Refractometer -- for determining salinity.
- 12.5.16 Thermometers, glass or electronic, laboratory grade -- for measuring water temperatures.
- 12.5.17 Thermometers, bulb-thermograph or electronic-chart type -- for continuously recording temperature.
- 12.5.18 Thermometer, National Bureau of Standards Certified (see USEPA Method 170.1, USEPA, 1979b) -- to calibrate laboratory thermometers.
- 12.5.19 Test chambers -- four (minimum of three); borosilicate glass or non-toxic plastic labware per test concentration. Care must be taken to avoid inadvertently removing embryos or larvae when test solutions are decanted from the chambers. To avoid potential contamination from the air and excessive evaporation of test solutions during the test, the chambers should be covered with safety glass plates or sheet plastic (6 mm thick). The covers are removed only for observation and removal of dead organisms.
- 12.5.20 Beakers -- six Class A, borosilicate glass or non-toxic plasticware, 1000 mL for making test solutions.
- 12.5.21 Wash bottles -- for deionized water, for washing embryos from substrates and containers, and for rinsing small glassware and instrument electrodes and probes.
- 12.5.22 Volumetric flasks and graduated cylinders -- Class A, borosilicate glass or non-toxic plastic labware, 10-1000 mL for making test solutions.
- 12.5.23 Pipets, volumetric -- Class A, 1-100 mL.
- 12.5.24 Pipets, automatic -- adjustable, 1-100 mL.
- 12.5.25 Pipets, serological -- 1-10 mL, graduated.
- 12.5.26 Pipet bulbs and fillers -- PROPIPET®, or equivalent.
- 12.5.27 Droppers and glass tubing with fire polished apertures, 4 mm ID -- for transferring embryos and larvae.

12.5.28 Siphon with bulb and clamp -- for cleaning test chambers.

12.5.29 NITEX® or stainless steel mesh sieves, ($\leq 150 \mu\text{m}$, $500 \mu\text{m}$, and 3 to 5 mm) -- for collecting *Artemia* nauplii and fish embryos, and for spawning baskets, respectively (NITEX® is available from Sterling Marine Products, 18 Label Street, Montclair, NJ 07042; 201-783-9800).

12.6 REAGENTS AND CONSUMABLE MATERIALS

12.6.1 Sample containers -- for sample shipment and storage (see Section 8, Effluent and Receiving Water Sampling, Sample Handling, and Sample Preparation for Toxicity Tests).

12.6.2 Data sheets (one set per test) -- for data recording (see Figure 1).

12.6.3 Tape, colored -- for labelling test chambers.

12.6.4 Markers, waterproof -- for marking containers, etc.

12.6.5 Buffers, pH 4, pH 7, and pH 10 (or as per instructions of instrument manufacturer) -- for standards and calibration check (see USEPA Method 150.1, USEPA, 1979b).

12.6.6 Membranes and filling solutions for dissolved oxygen probe (see USEPA Method 360.1, USEPA, 1979b), or reagents -- for modified Winkler analysis.

12.6.7 Laboratory quality assurance samples and standards -- for calibration of the above methods.

12.6.8 Reference toxicant solutions -- see Section 4, Quality Assurance.

12.6.9 Reagent water -- defined as distilled or deionized water that does not contain substances which are toxic to the test organisms (see Section 5, Facilities, Equipment, and Supplies).

12.6.10 Effluent, receiving water, and dilution water -- see Section 7, Dilution Water, and Section 8, Effluent and Receiving Water Sampling, Sample Handling, and Sample Preparation for Toxicity Tests.

12.6.10.1 Saline test and dilution water -- The salinity of the test water must be in the range of 5 to 32‰. The salinity should vary no more than ± 2 ‰ among chambers on a given day. If effluent and receiving water tests are conducted concurrently, the salinities of the water should be similar.

12.6.10.2 The overwhelming majority of industrial and sewage treatment effluents entering marine and estuarine systems contain little or no measurable salts. Exposure of sheepshead minnow embryos to these effluents will require adjustments in the salinity of the test solutions. It is important to maintain a constant salinity across all treatments. If in addition, it may be desirable to match the test salinity with that of the receiving water. Two methods are available to adjust salinities -- a hypersaline brine derived from natural seawater or artificial sea salts.

Test Dates: _____ Species: _____

Type Effluent: _____ Field: _____ Lab: _____ Test: _____

Effluent Tested: _____

Original pH: _____ Salinity: _____ D.O.: _____

CONCENTRATION:
Replicate I:

DAY	0	1	2	3	4	5	6	7	8	9
#Live/Dead Embryo-Larvae										
Terata										
Temp. (°C)										
Salinity (ppt)										
D.O. (mg/L)										
pH										

CONCENTRATION:
Replicate II:

DAY	0	1	2	3	4	5	6	7	8	9
#Live/Dead Embryo-Larvae										
Terata										
Temp. (°C)										
Salinity (ppt)										
D.O. (mg/L)										
pH										

Comments: _____

Note: Final endpoint for this test is total mortality (combined total number of dead embryos, dead larvae, and deformed larvae) (see Subsection 12.10.8 and 12.13).

Figure 1. Data form for sheepshead minnow, *Cyprinodon variegatus*, embryo-larval survival/teratogenicity test. Daily record of embryo-larval survival/terata and test conditions.

CONCENTRATION:
Replicate III:

DAY	0	1	2	3	4	5	6	7	8	9
#Live/Dead Embryo-Larvae										
Terata										
Temp. (°)										
Salinity (ppt)										
D.O. (mg/L)										
pH										

CONCENTRATION:
REPLICATE IV

DAY	0	1	2	3	4	5	6	7	8	9
#Live/Dead Embryo-Larvae										
Terata										
Temp. (°C)										
Salinity (ppt)										
D.O. (mg/L)										
pH										

Comments: _____

Note: Final endpoint for this test is total mortality (combined total number of dead embryos, dead larvae, and deformed larvae) (see Subsection 12.10.8 and 12.13).

Figure 1. Data form for sheepshead minnow, *Cyprinodon variegatus*, embryo-larval survival/teratogenicity test. Daily record of embryo-larval survival/terata and test conditions (CONTINUED).

12.6.10.3 Hypersaline brine (HSB): HSB has several advantages that make it desirable for use in toxicity testing. It can be made from any high quality, filtered seawater by evaporation, and can be added to the effluent or to deionized water to increase the salinity. HSB derived from natural seawater contains the necessary trace metals, biogenic colloids, and some of the microbial components necessary for adequate growth, survival, and/or reproduction of marine and estuarine organisms, and may be stored for prolonged periods without any apparent degradation. However if 100% HSB is used as a diluent, the maximum concentration of effluent that can be tested using HSB is limited to 80% at 20‰ salinity, and 70% at 30‰ salinity.

12.6.10.3.1 The ideal container for making HSB from natural seawater is one that (1) has a high surface to volume ratio, (2) is made of a non-corrosive material, and (3) is easily cleaned (fiberglass containers are ideal). Special care should be used to prevent any toxic materials from coming in contact with the seawater being used to generate the brine. If a heater is immersed directly into the seawater, ensure that the heater materials do not corrode or leach any substances that would contaminate the brine. One successful method used is a thermostatically controlled heat exchanger made from fiberglass. If aeration is used, use only oil-free air compressors to prevent contamination.

12.6.10.3.2 Before adding seawater to the brine generator, thoroughly clean the generator, aeration supply tube, heater, and any other materials that will be in direct contact with the brine. A good quality biodegradable detergent should be used, followed by several (at least three) thorough deionized water rinses.

12.6.10.3.3 High quality (and preferably high salinity) seawater should be filtered to at least 10 μm before placing into the brine generator. Water should be collected on an incoming tide to minimize the possibility of contamination.

12.6.10.3.4 The temperature of the seawater is increased slowly to 40°C. The water should be aerated to prevent temperature stratification and to increase water evaporation. The brine should be checked daily (depending on volume being generated) to ensure that salinity does not exceed 100‰ and that the temperature does not exceed 40°C. Additional seawater may be added to the brine to obtain the volume of brine required.

12.6.10.3.5 After the required salinity is attained, the HSB should be filtered a second time through a 1 μm filter and poured directly into portable containers (20-L) cubitainers or polycarbonate water cooler jugs are suitable. The containers should be capped and labelled with the date the brine was generated and its salinity. Containers of HSB should be stored in the dark and maintained at room temperature until used.

12.6.10.3.6 If a source of HSB is available, test solutions can be made by following the directions below. Thoroughly mix together the deionized water and brine before mixing in the effluent.

12.6.10.3.7 Divide the salinity of the HSB by the expected test salinity to determine the proportion of deionized water to brine. For example, if the salinity of the HSB is 100‰ and the test is to be conducted at 20‰, $100‰ \div 20‰ = 5.0$. The proportion of brine is 1 part in 5 (one part brine to four parts deionized water). To make 1 L of seawater at 20‰ salinity from a HSB of 100‰, divide 1 L (1000 mL) by 5.0. The result, 200 mL, is the quantity of HSB needed to make 1 L of sea water. The difference, 800 mL, is the quantity of deionized water required.

12.6.10.3.8 Table 1 illustrates the composition of test solutions at 20‰ if they are prepared by serial dilution of effluent with 20‰ salinity seawater.

12.6.10.4 Artificial sea salts: HW MARINEMIX® brand sea salts (Hawaiian Marine Imports Inc., 10801 Kempwood, Suite 2, Houston, TX 77043) have been used successfully at the USEPA, Region 6, Houston laboratory to culture sheepshead minnows and perform the embryo-larval survival and teratogenicity test. EMSL-Cincinnati has found FORTY FATHOMS® artificial sea salts (Marine Enterprises, Inc., 8755 Mylander Lane, Baltimore, MD 21204; 301-321-1189), to be suitable for culturing sheepshead minnows and for performing the larval survival and growth test and embryo-larval test. Artificial sea salts may be used for culturing sheepshead minnows and for the embryo-larval test if the criteria for acceptability of test data are satisfied (see Subsection 12.11).

12.6.10.4.1 Synthetic sea salts are packaged in plastic bags and mixed with deionized water or equivalent. The instructions on the package of sea salts should be followed carefully, and salts should be mixed in a separate container -- not the culture tank. The deionized water used in hydration should be in the temperature range of 21-26°C. Seawater made from artificial sea salts is conditioned (Spotte, 1973; Spotte et al., 1984; Bower, 1983) before it is used for culturing or testing. After adding the water, place an airstone in the container, cover, and aerate the solution mildly for at least 24 h before use.

12.6.11 BRINE SHRIMP, *ARTEMIA*, CULTURE -- for feeding cultures.

12.6.11.1 Newly-hatched *Artemia* nauplii are used as food in the sheepshead minnow culture, and a brine shrimp culture unit should be prepared (USEPA, 1993a). Although there are many commercial sources of brine shrimp cysts, the Brazilian or Colombian strains are currently preferred because the supplies examined have had low concentrations of chemical residues and produce nauplii of suitably small size. For commercial sources of brine shrimp, *Artemia*, cysts, see Table 2 of Section 5, Facilities, Equipment, and Supplies; and Section 4, Quality Assurance.

12.6.11.2 Each new batch of *Artemia* cysts must be evaluated for size (Vanhaecke and Sorgeloos, 1980, and Vanhaecke et al., 1980) and nutritional suitability (Leger, et al., 1985; Leger, et al., 1986) against known suitable reference cysts by performing a side by side larval growth test using the "new" and "reference" cysts. The "reference" cysts used in the suitability test may be a previously tested and acceptable batch of cysts, or may be obtained from the Quality Assurance Research Division, Environmental

TABLE 1. PREPARATION OF TEST SOLUTIONS AT A SALINITY OF 20‰, USING 20‰ NATURAL OR ARTIFICIAL SEAWATER, HYPERSALINE BRINE, OR ARTIFICIAL SEA SALTS

Effluent Solution	Effluent Conc. (%)	Solutions To Be Combined	
		Volume of Effluent Solution	Volume of Diluent Seawater (20‰)
1	100 ^{1,2}	4000 mL	---
2	50	2000 mL Solution 1	+ 2000 mL
3	25	2000 mL Solution 2	+ 2000 mL
4	12.5	2000 mL Solution 3	+ 2000 mL
5	6.25	2000 mL Solution 4	+ 2000 mL
Control	0.0		2000 mL
Total		10000 mL	

¹ This illustration assumes: (1) the use of 400 mL of test solution in each of four replicates and 400 mL for chemical analysis (total of 2000 mL) for the control and five concentrations of effluent (2) an effluent dilution factor of 0.5, and (3) the effluent lacks appreciable salinity. A sufficient initial volume (4000 mL) of effluent is prepared by adjusting the salinity to the desired level. In this example, the salinity is adjusted by adding artificial sea salts to the 100% effluent, and preparing a serial dilution using 20‰ seawater (natural seawater, hypersaline brine, or artificial seawater). The salinity of the initial 4000 mL of 100% effluent is adjusted to 20‰ by adding 80 g of dry artificial sea salts (HW MARINEMIX or FORTY FATHOMS®), and mixing for 1 h. Test concentrations are then made by mixing appropriate volumes of salinity-adjusted effluent and 20‰ salinity dilution water to provide 4000 mL of solution for each concentration. If hypersaline brine alone (100‰) is used to adjust the salinity of the effluent, the highest concentration of effluent that could be achieved would be 80% at 20‰ salinity, and 70% at 30‰ salinity.

² The same procedures would be followed in preparing test concentrations at other salinities between 20‰ and 30‰: (1) The salinity of the bulk (initial) effluent sample would be adjusted to the appropriate salinity using artificial sea salts or hypersaline brine, and (2) the remaining effluent concentrations would be prepared by serial dilution, using a large batch (10 L) of seawater for dilution water, which had been prepared at the same salinity as the effluent, using natural seawater, hypersaline and deionized water.

Monitoring Systems Laboratory, Cincinnati, OH 45268; 513-569-7325. A sample of newly hatched *Artemia* nauplii from each new batch of cysts should be chemically analyzed. The *Artemia* cysts should not be used if the concentration of total organic chlorine pesticides exceeds 0.15 $\mu\text{g/g}$ wet weight or the total concentration of organochlorine pesticides plus PCBs exceeds 0.30 $\mu\text{g/g}$ wet weight. (For analytical methods see USEPA, 1982).

12.6.11.3 *Artemia* nauplii are obtained as follows:

1. Add 1 L of seawater, or a solution prepared by adding 35.0 g uniodized salt (NaCl) or artificial sea salts to 1 L of deionized water, to a 2-L separatory funnel, or equivalent.
2. Add 10 mL *Artemia* cysts to the separatory funnel and aerate for 24 h at 27°C. (Hatching time varies with incubation temperature and the geographic strain of *Artemia* used (see USEPA, 1985d, USEPA, 1993a; and ASTM, 1993).
3. After 24 h, cut off the air supply in the separatory funnel. *Artemia* nauplii are phototactic, and will concentrate at the bottom of the funnel if it is covered for 5-10 minutes. To prevent mortality, do not leave the concentrated nauplii at the bottom of the funnel more than 10 min without aeration.
4. Drain the nauplii into a beaker or funnel fitted with a $\leq 150 \mu\text{m}$ NITEX® or stainless steel screen, and rinse with seawater or equivalent before use.

12.6.11.4 Testing *Artemia* nauplii as food for toxicity test organisms.

12.6.11.4.1 The primary criterion for acceptability of each new supply of brine shrimp cysts is the ability of the nauplii to support good survival and growth of the sheepshead minnow larvae. The larvae used to evaluate the suitability of the brine shrimp nauplii must be of the same geographical origin, species, and stage of development as those used routinely in the toxicity tests. Sufficient data to detect differences in survival and growth should be obtained by using three replicate test vessels, each containing a minimum of 15 larvae, for each type of food.

12.6.11.4.2 The feeding rate and frequency, test vessels, volume of control water, duration of the test, and age of the nauplii at the start of the test, should be the same as used for the routine toxicity tests.

12.6.11.4.3 Results of the brine shrimp nutrition assay, where there are only two treatments, can be evaluated statistically by use of a t test. The "new" food is acceptable if there are no statistically significant differences in the survival and growth of the larvae fed the two sources of nauplii.

12.6.11.4.4 The average seven-day survival of larvae should be 80% or greater, and (2) the average dry weight of larvae should be 0.60 mg or greater, if dried and weighed immediately after the test, or (3) the average dry weight of larvae should be 0.50 mg or greater, if the larvae are preserved in 4% formalin before drying and weighing. The above minimum weights presume that the age of the larvae at the start of the test is not greater than 24 h.

12.6.12 TEST ORGANISMS, SHEEPSHEAD MINNOWS, *CYPRINODON VARIEGATUS*

12.6.12.1 Brood Stock

12.6.12.1.1 Adult sheepshead minnows for use as brood stock may be obtained by seine in Gulf of Mexico and Atlantic coast estuaries, from commercial sources, or from young fish raised to maturity in the laboratory. Feral brood stocks and first generation laboratory fish are preferred, to minimize inbreeding.

12.6.12.1.2 To detect disease and to allow time for acute mortality due to the stress of capture, field-caught adults are observed in the laboratory a minimum of two weeks before using as a source of gametes. Injured or diseased fish are discarded.

12.6.12.1.3 Sheepshead minnows can be continuously cultured in the laboratory from eggs to adults. The larvae, juvenile, and adult fish should be kept in appropriate size rearing tanks, maintained at ambient laboratory temperature. The larvae should be fed sufficient newly hatched *Artemia* nauplii daily to assure that live nauplii are always present. Juveniles are fed frozen adult brine shrimp and a commercial flake food, such as TETRA SM-80[®], available from Tetra Sales (U.S.A), 201 Tabor Road, Morris Plains, NJ 07950; 800-526-0650, or MARDEL AQUARIAN[®] Tropical Fish Flakes, available from Mardel Laboratories, Inc., 1958 Brandon Court, Glendale Heights, IL 60139; 312-351-0606, or equivalent. Adult fish are fed flake food three or four times daily, supplemented with frozen adult brine shrimp.

12.6.12.1.3.1 Sheepshead minnows reach sexual maturity in three-to-five months after hatch, and have an average standard length of approximately 27 mm for females and 34 mm for males. At this time, the males begin to exhibit sexual dimorphism and initiate territorial behavior. When the fish reach sexual maturity and are to be used for natural spawning, the temperature should be controlled at 18-20°C.

12.6.12.1.4 Adults can be maintained in natural or artificial seawater in a flow-through or recirculating, aerated system consisting of an all-glass aquarium, or a "Living Stream" (Figid Unit, Inc., 3214 Sylvania Avenue, Toledo, OH 43613; 419-474-6971), or equivalent.

12.6.12.1.5 The system is equipped with an undergravel or outside biological filter of shells (see Spotte, 1973 or Bower, 1983 for conditioning the biological filter), or a cartridge filter, such as a MAGNUM[®] Filter, available from Carolina Biological Supply Co., Burlington, NC 27215; 800-334-5551, or an EHEIM[®] Filter, available from Hawaiian Marine Imports Inc., P.O. Box 218687, Houston, TX 77218; 713-492-7864, or equivalent, at a salinity of 20-30‰ and a photoperiod of 16 h light/8 h dark.

12.6.12.2 Obtaining Embryos for Toxicity Tests

12.6.12.2.1 Embryos can be shipped to the laboratory from an outside source or obtained from adults held in the laboratory. Ripe eggs can be obtained either by natural spawning or by intraperitoneal injection of the females with

human chorionic gonadotrophin (HCG) hormone, available from United States Biochemical Corporation, Cleveland, OH 44128; 216-765-5000. If the culturing system for adults is temperature controlled, natural spawning can be induced. Natural spawning is preferred because repeated spawnings can be obtained from the same brood stock, whereas with hormone injection, the brood stock is sacrificed in obtaining gametes.

12.6.12.2.2 It should be emphasized that the injection and hatching schedules given below are to be used only as guidelines. Response to the hormone varies from stock to stock and with temperature. Time to hatch and percent hatch also vary among stocks and among batches of embryos obtained from the same stock, and are dependent on temperature, DO, and salinity.

12.6.12.2.3 Forced Spawning

12.6.12.2.3.1 HCG is reconstituted with sterile saline or Ringer's solution immediately before use. The standard HCG vial contains 1,000 IU to be reconstituted in 10 mL of saline. Freeze-dried HCG which comes with premeasured and sterilized saline is the easiest to use. Use of a 50 IU dose requires injection of 0.05 mL of reconstituted hormone solution. Reconstituted HCG may be used for several weeks if kept in the refrigerator.

12.6.12.2.3.2 Each female is injected intraperitoneally with 50 IU HCG on two consecutive days, starting at least 4 days prior to the beginning of a test. Two days following the second injection, eggs are stripped from the females and mixed with sperm derived from excised macerated testes. At least ten females and five males are used per test to ensure that there is a sufficient number of viable embryos.

12.6.12.2.3.3 HCG is injected into the peritoneal cavity, just below the skin, using as small a needle as possible. A 50 IU dose is recommended for females approximately 27 mm in standard length. A larger or smaller dose may be used for fish which are significantly larger or smaller than 27 mm. With injections made on days one and two, females which are held at 25°C should be ready for stripping on Day 4. Ripe females should show pronounced abdominal swelling, and release at least a few eggs in response to a gentle squeeze. Injected females should be isolated from males. It may be helpful if fish that are to be injected are maintained at 20°C before injection, and the temperature raised to 25°C on the day of the first injection.

12.6.12.2.3.4 Prepare the testes immediately before stripping the eggs from the females. Remove the testes from three-to-five males. The testes are paired, dark grey organs along the dorsal midline of the abdominal cavity. If the head of the male is cut off and pulled away from the rest of the fish, most of the internal organs can be pulled out of the body cavity, leaving the testes behind. The testes are placed in a few mL of seawater until the eggs are ready.

12.6.12.2.3.5 Strip the eggs from the females, into a dish containing 50-100 mL of seawater, by firmly squeezing the abdomen. Sacrifice the females and remove the ovaries if all the ripe eggs do not flow out freely. Break up any

clumps of ripe eggs and remove clumps of ovarian tissue and underripe eggs. Ripe eggs are spherical, approximately 1 mm in diameter, and almost clear.

12.6.12.2.3.6 While being held over the dish containing the eggs, the testes are macerated in a fold of NITEX® screen (250-500 μm mesh) dampened with seawater. The testes are then rinsed with seawater to remove the sperm from tissue, and the remaining sperm and testes are washed into the dish. Let the eggs and milt stand together for 10-15 min, swirling occasionally.

12.6.12.2.3.7 Pour the contents of the dish into a beaker, and insert an airstone. Aerate gently, such that the water moves slowly over the eggs, and incubate at 25°C for 60-90 min. After incubation, wash the eggs on a NITEX® screen and resuspend them in clean seawater.

12.6.12.2.4 Natural Spawning

12.6.12.2.4.1 Short-term (Demand) Embryo Production

12.6.12.2.4.1.1 Adult fish should be maintained at 18-20°C in a temperature controlled system. To obtain embryos for a test, adult fish (generally, at least eight-to-ten females and three males) are transferred to a spawning chamber, with a photoperiod of 16 h light/8 h dark and a temperature of 25°C, two days before the beginning of the test. The spawning chambers are approximately 20 X 35 X 22 cm high (USEPA, 1978), and consist of a basket of 3-5 mm NITEX® mesh, made to fit into a 57-L (15 gal) aquarium. Spawning generally will begin within 24 h or less. The embryos will fall through the bottom of the basket and onto a collecting screen (250-500 μm mesh) or tray below the basket. The collecting tray should be checked for embryos the next morning. The number of eggs produced is highly variable. The number of spawning units required to provide the embryos needed to perform a toxicity test is determined by experience. If the trays do not contain sufficient embryos after the first 24 h, discard the embryos, replace the trays, and collect the embryos for another 24 h or less. To help keep the embryos clean, the adults are fed while the screens are removed.

12.6.12.2.4.1.2 The embryos are collected in a tray placed on the bottom of the tank. The collecting tray consists of \pm 150 μm NITEX® screen attached to a rigid plastic frame. The collecting trays with newly-spawned, embryos are removed from the spawning tank, and the embryos are collected from the screens by washing them with a wash bottle or removing them with a fine brush. The embryos from several spawning units may be pooled in a single container to provide a sufficient number to conduct the test(s). The embryos are transferred into a petri dish or equivalent, filled with fresh culture water, and are examined using a dissecting microscope or other suitable magnifying device. Damaged and infertile eggs are discarded (see Figure 2). It is strongly recommended that the embryos be obtained from fish cultured in-house, rather than from outside sources, to eliminate the uncertainty of damage caused by shipping and handling that may not be observable, but which might affect the results of the test.

12.6.12.2.4.1.3 After sufficient embryos are collected for the test, the adult fish are returned to the (18-20°C) culture tanks.

12.6.12.2.4.2 Sustained Natural Embryo Production

12.6.12.2.4.2.1 Sustained (long-term), daily, embryo production can be achieved by maintaining mature fish in tanks, such as a (285-L or 75-gal) LIVING STREAM® tank, at a temperature of 23-25°C. Embryos are produced daily, and when needed, embryo "collectors" are placed on the bottom of the tank on the afternoon preceding the start of the test. The next morning, the embryo collectors are removed and the embryos are washed into a shallow glass culture dish using artificial seawater.

12.6.12.2.4.2.2 Four embryo collectors, approximately 20 cm X 45 cm, will approximately cover the bottom of the 285-L tank. The collectors are fabricated from plastic fluorescent light fixture diffusors (grids), with cells approximately 14 mm deep X 14 mm square. A screen consisting of 500 μm mesh is attached to one side (bottom) of the grid with silicone adhesive. The depth and small size of the grid protects the embryos from predation by the adult fish.

12.6.12.2.4.2.3 The brood stock is replaced annually with feral stock.

12.6.12.2.5 Test Organisms

12.6.12.2.5.1 Embryos spawned over a less than 24-h period, are used for the test. These embryos may be used immediately to start a test or may be placed in a suitable container and transported for use at a remote location. When overnight transportation is required, embryos should be obtained when they are no more than 8-h old. This permits the tests at the remote site to be started with less than 24-h old embryos. Embryos should be transported or shipped in clean, insulated containers, in well aerated or oxygenated fresh seawater or aged artificial sea water of correct salinity, and should be protected from extremes of temperature and any other stressful conditions during transport. Instantaneous changes of water temperature when embryos are transferred from culture unit water to test dilution water, or from transport container water to on-site test dilution, should be less than 2°C. Instantaneous changes of pH, dissolved ions, osmotic strength, and DO should also be kept to a minimum.

12.6.12.2.5.2 The number of embryos needed to start the test will depend on the number of tests to be conducted and the objectives. If the test is conducted with four replicate test chambers (minimum of three) at each toxicant concentration and in the control, with 15 embryos (minimum of 10) in each test chamber, and the combined mortality of embryos prior to the start of the test is less than 20%, 400 viable embryos are required for the test.

12.7 EFFLUENT AND RECEIVING WATER COLLECTION, PRESERVATION, AND STORAGE

12.7.1 See Section 8, Effluent and Receiving Water Sampling, Sample Handling, and Sample Preparation for Toxicity Tests.

12.8 CALIBRATION AND STANDARDIZATION

12.8.1 See Section 4, Quality Assurance.

12.9 QUALITY CONTROL

12.9.1 See Section 4, Quality Assurance.

12.10 TEST PROCEDURES

12.10.1 TEST SOLUTIONS

12.10.1.1 Receiving Waters

12.10.1.1.1 The sampling point is determined by the objectives of the test. At estuarine and marine sites, samples are usually collected at mid-depth. Receiving water toxicity is determined with samples used directly as collected or with samples passed through a 60 μm NITEX® filter and compared without dilution, against a control. Using four replicate chambers per test, each containing 400-500 mL, and 400 mL for chemical analysis, would require approximately 2.0-2.5 L or more of sample per test per day.

12.10.1.2 Effluents

12.10.1.2.1 The selection of the effluent test concentration should be based on the objectives of the study. A dilution factor of 0.5 is commonly used. A dilution factor of 0.5 provides precision of $\pm 100\%$, and allows for testing of concentrations between 6.25% and 100% effluent using only five effluent concentrations (6.25%, 12.5%, 25%, 50%, and 100%). Test precision shows little improvement as dilution factors are increased beyond 0.5 and declines rapidly if smaller dilution factors are used. **Therefore, USEPA recommends the use of the ≥ 0.5 dilution factor.** If 100‰ salinity HSB is used as a diluent, the maximum concentration of effluent that can be tested will be 80% at 20‰ and 70% at 30‰ salinity.

12.10.1.2.2 If the effluent is known or suspected to be highly toxic, a lower range of effluent concentrations should be used (such as 25%, 12.5%, 6.25%, 3.12%, and 1.56%). If a high rate of mortality is observed during the first 1-to-2 h of the test, additional dilutions at the lower range of effluent concentrations should be added.

12.10.1.2.3 The volume of effluent required to initiate the test and for daily renewal of four replicates (minimum of three) per concentration for five concentrations of effluent and a control, each containing 400 mL of test solution, is approximately 4 L. Prepare enough test solution (approximately 3000 mL) at each effluent concentration to refill the test chambers and provide at least 400 mL additional volume for chemical analyses.

12.10.1.2.4 Maintain the effluent at 4°C. Plastic containers such as 8-20 L cubitainers have proven successful for effluent collection and storage.

12.10.1.2.5 Just prior to test initiation (approximately 1 h), the temperature of a sufficient quantity of the sample(s) to make the test solutions should be adjusted to the test temperature ($25 \pm 1^\circ\text{C}$) and maintained at that temperature during the addition of dilution water.

12.10.1.2.6 Higher effluent concentrations (i.e., 25%, 50%, and 100%) may require aeration to maintain adequate dissolved oxygen concentrations. However, if one solution is aerated, all concentrations must be aerated. Aerate effluent as it warms and continue to gently aerate test solutions in the test chambers for the duration of the test.

12.10.1.2.7 Effluent dilutions should be prepared for all replicates in each treatment in one beaker to minimize variability among the replicates. The test chambers are labelled with the test concentration and replicate number. Dispense into the appropriate effluent dilution chamber.

12.10.1.3 Dilution Water

12.10.1.3.1 Dilution water may be uncontaminated natural seawater (receiving water), HSB prepared from natural seawater, or artificial seawater prepared from FORTY FATHOMS® or GP2 sea salts (see Table 3 and Section 7, Dilution Water). Other artificial sea salts may be used for culturing sheepshead minnows if the control criteria for acceptability of test data are satisfied.

12.10.2 START OF THE TEST

12.10.2.1 Tests should begin as soon as possible, preferably within 24 h after sample collection. For on-site toxicity studies, no more than 24 h should elapse between collection of the effluent and use in an embryo-larval study. The maximum holding time following retrieval of the sample from the sampling device should not exceed 36 h for off-site toxicity studies unless permission is granted by the permitting authority. In no case should the sample be used in a test more than 72 h after sample collection (see Section 8, Effluent and Receiving Water Sampling, Sample Handling, and Sample Preparation for Toxicity Tests).

12.10.2.2 Label the test chambers with a marking pen. Use color-coded tape to identify each treatment and replicate. A minimum of five effluent concentrations and a control are used for each effluent test. Each concentration (including controls) is to have four replicates (minimum of three). Use 500 mL beakers, crystallization dishes, nontoxic disposable plastic labware, or equivalent for test chambers.

12.10.2.3 Prepare the test solutions (see Table 1) and add to the test chambers.

12.10.2.4 Gently agitate and mix the embryos to be used in the test in a large container so that eggs from different spawns are evenly dispersed.

12.10.2.5 The test is started by randomly placing embryos from the common pool, using a small bore (2 mm), fire polished, glass tube calibrated to contain approximately the desired number of embryos, into each of four replicate test chamber, until each chamber contains 15 embryos (minimum of 10), for a total of 60 embryos (minimum of 30) for each concentration (four replicates recommended, three minimum) (see Appendix A). The amount of water added to the chambers when transferring the embryos should be kept to a minimum to avoid unnecessary dilution of the test concentrations.

12.10.2.6 After the embryos have been distributed to each test chamber, examine and count them. Remove and discard damaged or infertile eggs and replace with undamaged embryos. It may be more convenient and efficient to transfer embryos to intermediate containers of dilution water for examination and counting. After the embryos have been examined and counted in the intermediate container, assign them to the appropriate test chamber and transfer them with a minimum of dilution water.

12.10.2.7 Randomize the position of the test chambers at the beginning of the test (see Appendix A). Maintain the chambers in this configuration throughout the test. Preparation of a position chart may be helpful.

12.10.3 LIGHT, PHOTOPERIOD, SALINITY, AND TEMPERATURE

12.10.3.1 The light quality and intensity should be at ambient laboratory levels, approximately 10-20 $\mu\text{E}/\text{m}^2/\text{s}$, or 50 to 100 foot candles (ft-c), with a photoperiod of 16 h of light and 8 h of darkness. The test water temperature should be maintained at $25 \pm 1^\circ\text{C}$. The salinity should be 5‰ to $32\text{‰} \pm 2\text{‰}$ to accommodate receiving waters that may fall within this range. The salinity should vary no more than $\pm 2\text{‰}$ among the chambers on a given day. If effluent and receiving water tests are conducted concurrently, the salinities of these tests should be similar.

12.10.4 DISSOLVED OXYGEN (DO) CONCENTRATION

12.10.4.1 Aeration may affect the toxicity of effluents and should be used only as a last resort to maintain satisfactory DO. The DO should not fall below 4.0 mg/L (see Section 8, Effluent and Receiving Water Sampling, Sample Holding, and Sample Preparation for Toxicity Tests). If it is necessary to aerate, all treatments and the control should be aerated. The aeration rate should not exceed 100 bubbles/min, using a pipet with a 1-2 mm orifice, such as a 1-mL KIMAX® Serological Pipet No. 37033, or equivalent. Care should be taken to ensure that turbulence resulting from the aeration does not cause undue physical stress to the fish.

12.10.5 FEEDING

12.10.5.1 Feeding is not required.

12.10.6 OBSERVATIONS DURING THE TEST

12.10.6.1 Routine Chemical and Physical Determinations

12.10.6.1.1 DO is measured at the beginning and end of each 24-h exposure period at each test concentration and in the control.

12.10.6.1.2 Temperature, pH, and salinity are measured at the end of each 24-h exposure period in one test chamber at each test concentration and in the control. Temperature should also be monitored continuously or observed and recorded daily for at least two locations in the environmental control system or the samples. Temperature should be measured in a sufficient number of test

chambers at least at the end of the test to determine the temperature variation in the environmental chambers.

12.10.6.1.3 The pH is measured in the effluent sample each day before new test solutions are made.

12.10.6.1.4 Record all measurements on the data sheet (Figure 1).

12.10.6.2 Routine Biological Observations

12.10.6.2.1 At the end of the first 24 h of exposure, before renewing the test solutions, examine and count the embryos. Remove the dead embryos (milky colored and opaque) and record the number. If the rate of mortality or fungal infection exceeds 20% in the control chambers, or if excessive nonconcentration related mortality occurs, terminate the test and start a new test with new embryos. If the above mortality conditions do not occur, continue the test for the full nine days.

12.10.6.2.2 At 25°C, hatching begins on about the sixth day. After hatching begins, count the number of dead and live embryos and the number of hatched, dead, live, and deformed and/or debilitated larvae, daily (see Figure 2 for illustrations of morphological development of embryo and larva). Deformed larvae are those with gross morphological abnormalities such as curved spines, lack of appendages, lack of fusiform shape (non-distinct mass), a colored beating heart in an opaque mass, lack of mobility, abnormal swimming, or other characteristics that preclude survival. Remove dead embryos and dead and deformed larvae as previously discussed and record the numbers for all test observations (see Figure 2).

12.10.6.2.3 Protect the embryos and larvae from unnecessary disturbance during the test by carefully carrying out the daily test observations, solution renewals, and removal of dead organisms. Make sure the test organisms remain immersed during the performance of the above operations.

12.10.7 DAILY CLEANING OF TEST CHAMBERS

12.10.7.1 Since feeding is not required, test chambers are not cleaned daily unless accumulation of particulate matter at the bottom of the tank causes a problem.

12.10.8 TEST SOLUTION RENEWAL

12.10.8.1 The test solutions are renewed daily using freshly prepared solution, immediately after cleaning the test chambers. For on-site toxicity studies, fresh effluent and receiving water samples used in toxicity tests should be collected daily, and no more than 24 h should elapse between collection of the sample and use in the test (see Section 8, Effluent and Receiving Water Sampling, Sample Handling, and Sample Preparation for Toxicity Tests). For off-site tests, a minimum of three samples must be collected, preferably on days one, three, and five. Maintain the samples at 4°C until used.

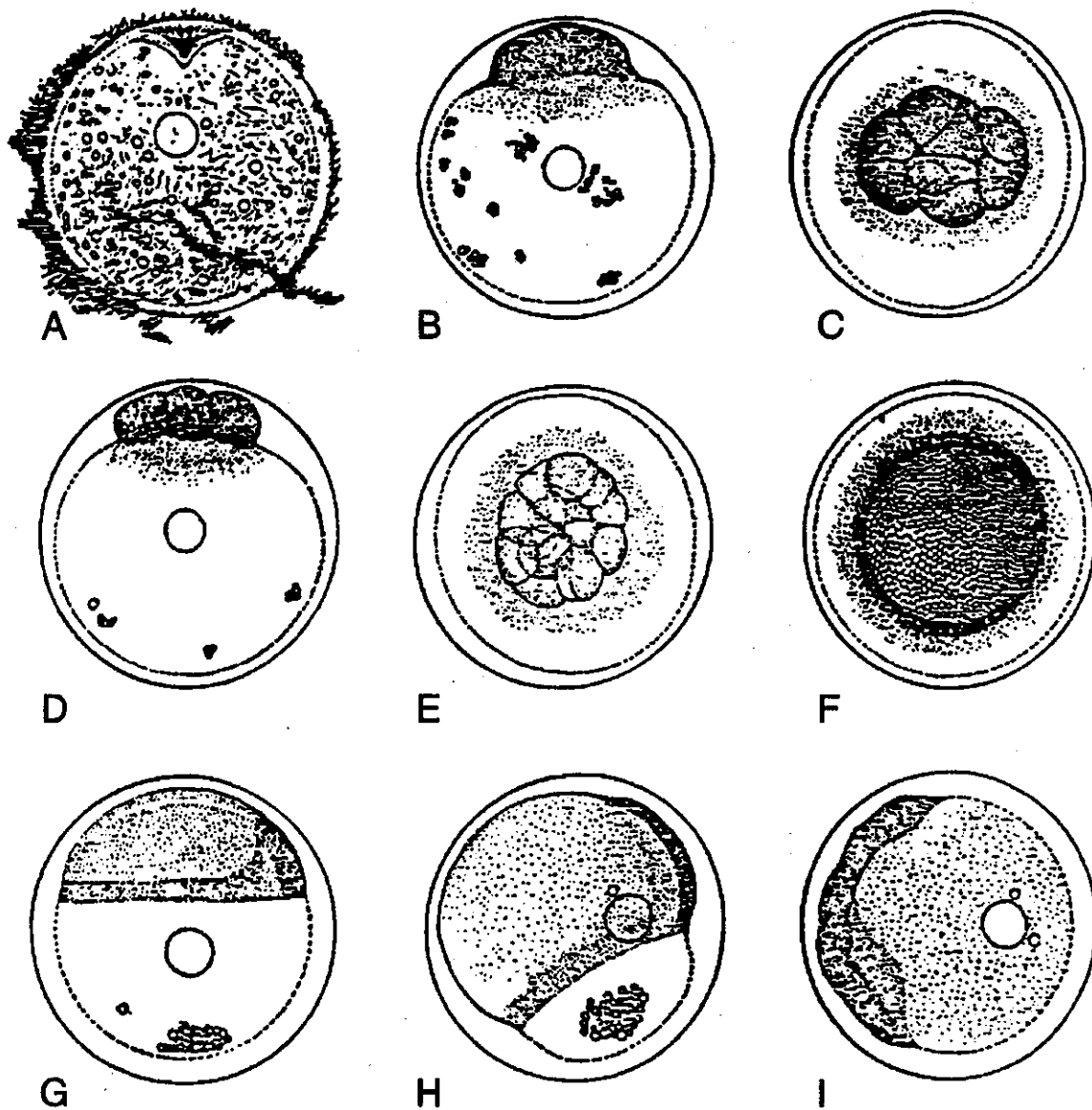

Figure 2. Embryonic development of sheepshead minnow, *Cyprinodon variegatus*: A. Mature unfertilized egg, showing attachment filaments and micropyle, X33; B. Blastodisc fully developed; C,D. Blastodisc, 8 cells; E. Blastoderm, 16 cells; F. Blastoderm, late cleavage stage; G. Blastoderm with germ ring formed, embryonic shield developing; H. Blastoderm covers over 3/4 of yolk, yolk noticeably constricted; I. Early embryo. From Kuntz (1916).

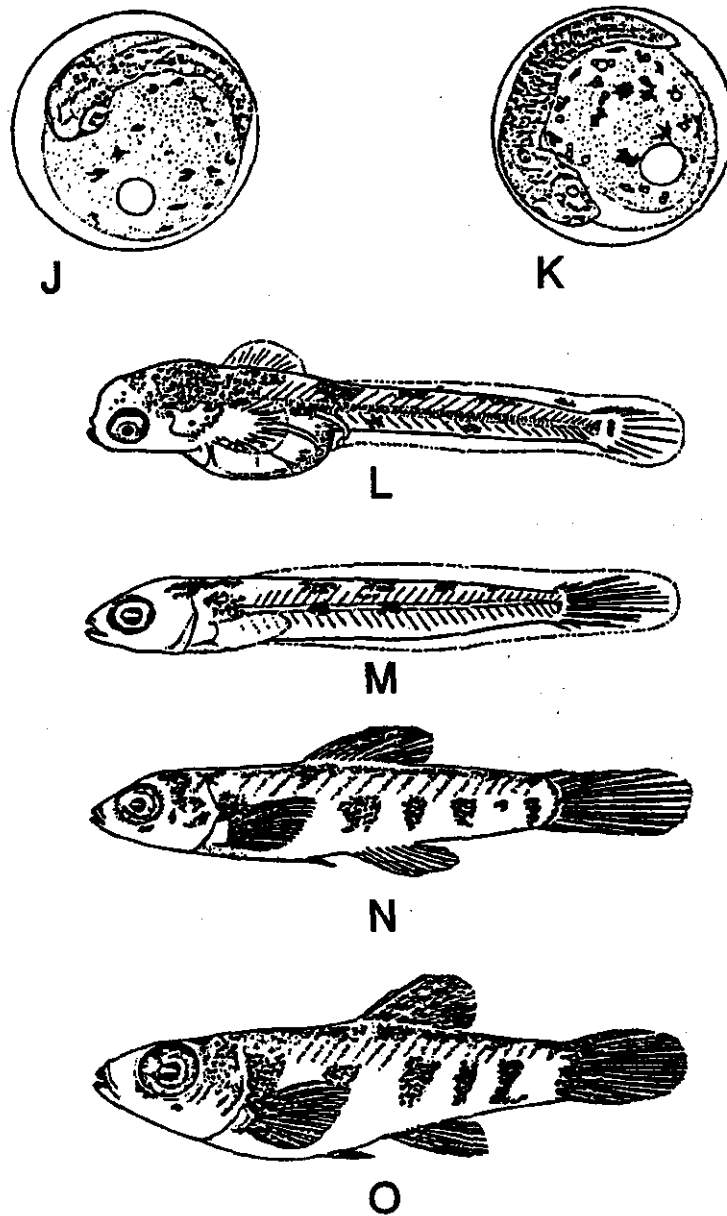

Figure 2. Embryonic development of sheephead minnow, *Cyprinodon variegatus*: J. Embryo 48 h after fertilization, now segmented throughout, pigment on yolk sac and body, otoliths formed; K. Posterior portion of embryo free from yolk and moves freely within egg membrane, 72 h after fertilization; L. Newly hatched fish, actual length 4 mm; M. Larval fish 5 days after hatching, actual length 5 mm; N. Young fish 9 mm in length; O. Young fish 12 mm in length (CONTINUED). From Kuntz (1916).

12.10.8.2 The test solutions are adjusted to the correct salinity and renewed daily using freshly collected samples. During the daily renewal process, 7-10 mm of water is left in the chamber to ensure that the embryos and larvae remain submerged during the renewal process. New test solution (400 mL) should be added slowly by pouring down the side of the test chamber to avoid exposing the embryos and larvae to excessive turbulence.

12.10.8.3 Prepare test solutions daily, making a minimum of five concentrations and a control. If concurrent effluent and receiving water testing occurs, the effluent test salinity should closely approximate that of the receiving water test. If an effluent is tested alone, select a salinity which approximately matches the salinity of the receiving waters. Table 1 illustrates the quantities of effluent, seawater, deionized water, and artificial sea salts needed to prepare 3 L of test solution at each effluent concentration for tests conducted at 20‰ salinity.

12.10.9 TERMINATION OF THE TEST

12.10.9.1 The test is terminated after nine days of exposure, or four days post-hatch, whichever comes first. Count the number of surviving, dead, and deformed and/or debilitated larvae, and record the numbers of each. The deformed larvae are treated as dead. Keep a separate record of the total number of deformed larvae for use in reporting the teratogenicity of the test solution.

12.11 ACCEPTABILITY OF TEST RESULTS

12.11.1 For the test results to be acceptable, survival in the controls must be at least 80% or better.

12.12 SUMMARY OF TEST CONDITIONS AND TEST ACCEPTABILITY CRITERIA

12.12.1 A summary of test conditions and test acceptability criteria is listed in Table 2.

12.13 DATA ANALYSIS

12.13.1 GENERAL

12.13.1.1 Tabulate and summarize the data.

12.13.1.2 The endpoints of this toxicity test are based on total mortality, combined number of dead embryos, dead larvae, and deformed larvae. The EC endpoints are calculated using Probit Analysis (Finney, 1971). LOEC and NOEC values, for total mortality, are obtained using a hypothesis test approach such as Dunnett's Procedure (Dunnett, 1955) or Steel's Many-one Rank Test (Steel, 1959; Miller, 1981). See the Appendices for examples of the manual computations, program listings, and examples of data input and program output.

TABLE 2. SUMMARY OF TEST CONDITIONS AND TEST ACCEPTABILITY CRITERIA FOR THE SHEEPSHEAD MINNOW, *CYPRINODON VARIEGATUS*, EMBRYO-LARVAL SURVIVAL AND TERATOGENICITY TEST WITH EFFLUENTS AND RECEIVING WATERS

1. Test type:	Static renewal
2. Salinity:	5‰ to 32‰ (\pm 2‰ of the selected test salinity)
3. Temperature:	25 \pm 1°C
4. Light quality:	Ambient laboratory light
5. Light intensity:	10-20 μ E/m ² /s, or 50-100 ft-c (ambient laboratory levels)
6. Photoperiod:	16 h light, 8 h darkness
7. Test chamber size:	400-500 mL
8. Test solution volume:	250-400 mL per replicate (loading and DO restrictions must be met)
9. Renewal of test solutions:	Daily
10. Age of test organisms:	less than 24 h old
11. No. of embryos per chamber:	15 (minimum of 10)
12. No. replicate test chambers per concentration:	4 (minimum of 3)
13. No. embryos per concentration:	60 (minimum of 30)
14. Feeding regime:	Feeding not required
15. Aeration:	None unless DO falls below 4.0 mg/L
16. Dilution water:	Uncontaminated source of natural seawater; deionized water mixed with hypersaline brine or artificial sea salts (HW Marinemix®, FORTY FATHOMS®, GP2, or equivalent)
17. Test concentrations:	Effluents: Minimum of 5 and a control Receiving waters: 100% receiving water or minimum of 5 and a control

TABLE 2. SUMMARY OF TEST CONDITIONS AND TEST ACCEPTABILITY CRITERIA FOR THE SHEEPSHEAD MINNOW, *CYPRINODON VARIEGATUS*, EMBRYO-LARVAL SURVIVAL AND TERATOGENICITY TEST WITH EFFLUENTS AND RECEIVING WATERS (CONTINUED)

18. Dilution factor:	Effluent: ≥ 0.5 Receiving waters: None, or ≥ 0.5
19. Test duration:	9 days
20. Endpoints:	Percent hatch; percent larvae dead or with debilitating morphological and/or behavior abnormalities such as: gross deformities; curved spine; disoriented, abnormal swimming behavior; surviving normal larvae from original embryos
21. Test acceptability criteria:	80% or greater survival in controls
22. Sampling requirements:	For on-site tests, samples collected daily and used within 24 h of the time they are removed from the sampling device. For off-site tests, a minimum of three samples are collected on days one, three, and five with a maximum holding time of 36 h before first use (see Section 8, Effluent and Receiving Water Sampling, Sample Handling, and Sample Preparation for Toxicity Tests, Subsection 8.5.4)
23. Sample volume required:	5 L per day

12.13.1.3 The statistical tests described here must be used with a knowledge of the assumptions upon which the tests are contingent. The assistance of a statistician is recommended for analysts who are not proficient in statistics.

12.13.2 EXAMPLE OF ANALYSIS OF SHEEPSHEAD MINNOW, *CYPRINODON VARIEGATUS*, EMBRYO-LARVAL SURVIVAL AND TERATOGENICITY DATA

12.13.2.1 Formal statistical analysis of the total mortality data is outlined in Figure 3. The response used in the analysis is the total mortality proportion in each test or control chamber. Separate analyses are performed for the estimation of the NOEC and LOEC endpoints and for the estimation of the EC endpoint. Concentrations at which there is 100% mortality in all of the test chambers are excluded from the statistical analysis of the NOEC and LOEC, but included in the estimation of the EC endpoints.

12.13.2.2 For the case of equal numbers of replicates across all concentrations and the control, the evaluation of the NOEC and LOEC endpoints is made via a parametric test, Dunnett's Procedure, or a nonparametric test, Steel's Many-one Rank Test, on the arc sine square root transformed data. Underlying assumptions of Dunnett's Procedure, normality and homogeneity of variance, are formally tested. The test for normality is the Shapiro-Wilk's Test, and Bartlett's Test is used to test for homogeneity of variance. If either of these tests fails, the nonparametric test, Steel's Many-one Rank Test, is used to determine the NOEC and LOEC endpoints. If the assumptions of Dunnett's Procedure are met, the endpoints are estimated by the parametric procedure.

12.13.2.3 If unequal numbers of replicates occur among the concentration levels tested, there are parametric and nonparametric alternative analyses. The parametric analysis is a t test with the Bonferroni adjustment (see Appendix D). The Wilcoxon Rank Sum Test with the Bonferroni adjustment is the nonparametric alternative.

12.13.2.4 Probit Analysis (Finney, 1971; see Appendix H) is used to estimate the concentration that causes a specified percent decrease in survival from the control. In this analysis, the total mortality data from all test replicates at a given concentration are combined. If the data do not fit the Probit Analysis, the Spearman-Kärber Method, the Trimmed Spearman-Kärber Method or the Graphical Method may be used (see Appendix H-K).

12.13.2.5 Example of Analysis of Survival Data

12.13.2.5.1 The data for this example are listed in Table 3. Total mortality, expressed as a proportion (combined total number of dead embryos, dead larvae and deformed larvae divided by the number of embryos at start of test), is the response of interest. The total mortality proportion in each replicate must first be transformed by the arc sine square root transformation procedure described in Appendix B. The raw and transformed data, means and variances of the transformed observations at each SDS concentration and control are listed in Table 3. A plot of the data is provided in Figure 4. Since there is 100% total mortality in all replicates for the 8.0 mg/L concentration, it is not included in this statistical analysis and is considered a qualitative mortality effect.

STATISTICAL ANALYSIS OF SHEEPSHEAD MINNOW EMBRYO-LARVAL SURVIVAL AND TERATOGENICITY TEST

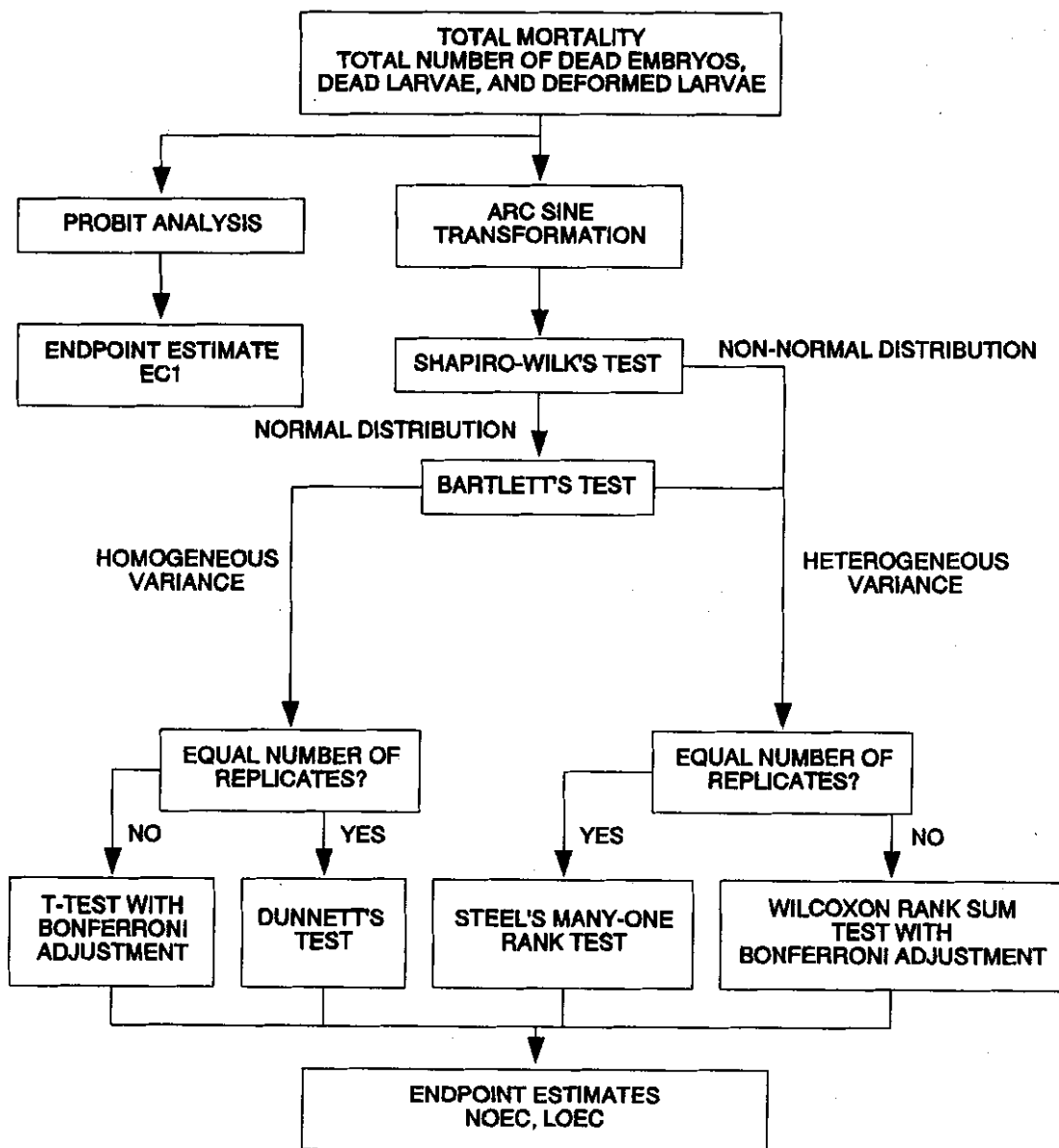

Figure 3. Flowchart for statistical analysis of sheephead minnow, *Cyprinodon variegatus*, embryo-larval survival and teratogenicity test. Survival and terata data.

TABLE 3. SHEEPSHEAD MINNOW, *CYPRINODON VARIEGATUS*, EMBRYO-LARVAL TOTAL MORTALITY DATA

Replicate	Control	SDS Concentration (mg/L)					
		0.5	1.0	2.0	4.0	8.0	
RAW	A	0.1	0.0	0.0	0.3	0.9	1.0
	B	0.0	0.2	0.1	0.1	0.7	1.0
	C	0.1	0.2	0.1	0.2	0.8	1.0
	D	0.0	0.1	0.2	0.4	0.8	1.0
<hr/>							
ARC SINE TRANS- FORMED	A	0.322	0.159	0.159	0.580	1.249	-
	B	0.159	0.464	0.322	0.322	0.991	-
	C	0.322	0.464	0.322	0.464	1.107	-
	D	0.159	0.322	0.464	0.685	1.107	-
<hr/>							
Mean (\bar{Y}_i)	0.241	0.352	0.317	0.513	1.114		
S_i^2	0.009	0.021	0.016	0.024	0.011		
i	1	2	3	4	5		

12.13.2.6 Test for Normality

12.13.2.6.1 The first step of the test for normality is to center the observations by subtracting the mean of all observations within a concentration from each observation in that concentration. The centered observations are summarized in Table 4.

TABLE 4. CENTERED OBSERVATIONS FOR SHAPIRO-WILK'S EXAMPLE

Replicate	Control	SDS Concentration (mg/L)				
		0.5	1.0	2.0	4.0	8.0
A	0.081	-0.193	-0.158	0.067	0.135	-
B	-0.082	0.112	0.005	-0.191	-0.123	-
C	0.081	0.112	0.005	-0.049	-0.007	-
D	-0.082	-0.030	0.147	0.172	-0.007	-

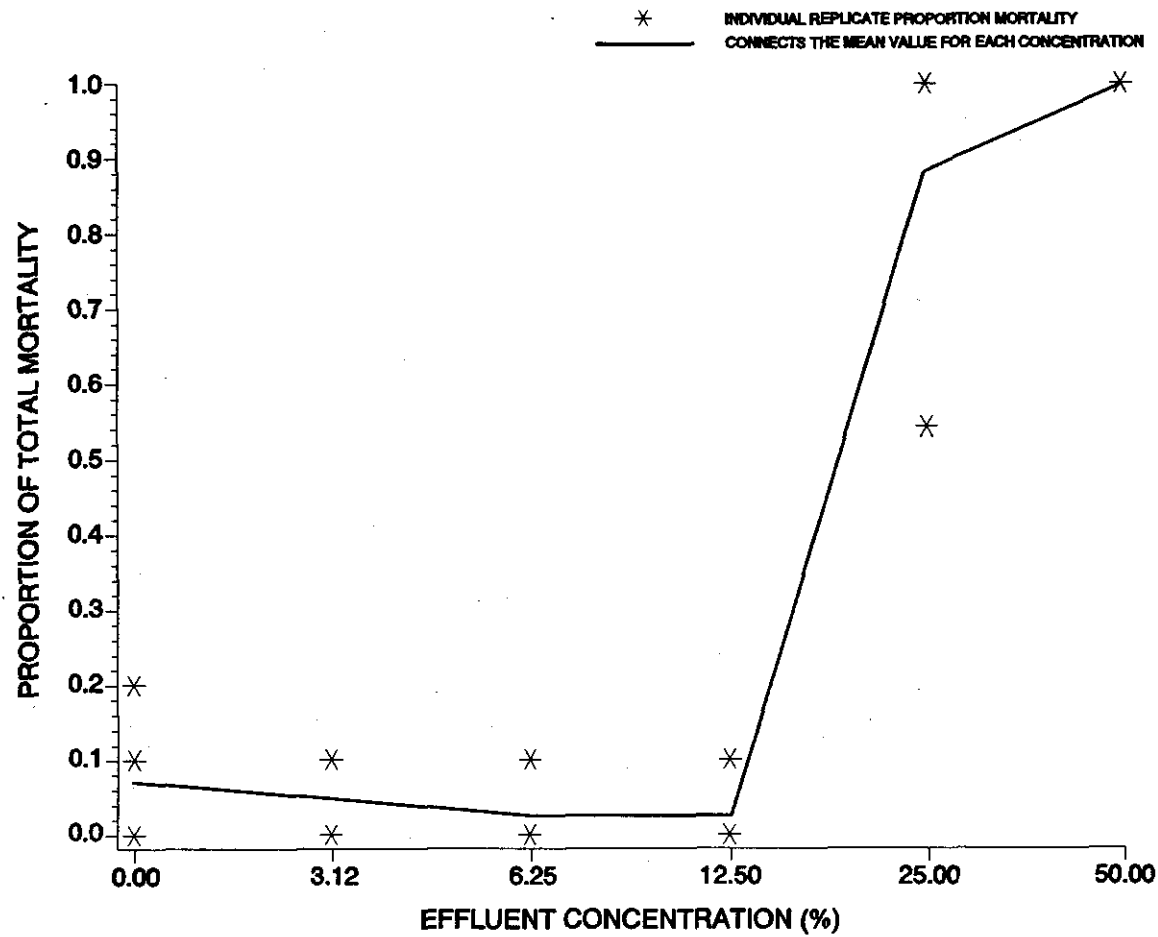

Figure 4. Plot of sheephead minnow, *Cyprinodon variegatus*, total mortality data from the embryo-larval test.

12.13.2.6.2 Calculate the denominator, D, of the statistic:

$$D = \sum_{i=1}^n (X_i - \bar{X})^2$$

Where: X_i = the i th centered observation

\bar{X} = the overall mean of the centered observations

n = the total number of centered observations

12.13.2.6.3 For this set of data, $n = 20$

$$\bar{X} = \frac{1}{20} (-0.005) = 0.000$$

$$D = 0.2428$$

12.13.2.6.4 Order the centered observations from smallest to largest

$$X^{(1)} \leq X^{(2)} \leq \dots \leq X^{(n)}$$

where $X^{(i)}$ denotes the i th ordered observation. The ordered observations for this example are listed in Table 5.

TABLE 5. ORDERED CENTERED OBSERVATIONS FOR SHAPIRO-WILK'S EXAMPLE

i	$X^{(i)}$	i	$X^{(i)}$
1	-0.193	11	0.005
2	-0.191	12	0.005
3	-0.158	13	0.067
4	-0.123	14	0.081
5	-0.082	15	0.081
6	-0.082	16	0.112
7	-0.049	17	0.112
8	-0.030	18	0.135
9	-0.007	19	0.147
10	-0.007	20	0.172

12.13.2.6.5 From Table 4, Appendix B, for the number of observations, n , obtain the coefficients a_1, a_2, \dots, a_k where k is $n/2$ if n is even and $(n-1)/2$ if n is odd. For the data in this example, $n = 20$ and $k = 10$. The a_i values are listed in Table 6.

TABLE 6. COEFFICIENTS AND DIFFERENCES FOR SHAPIRO-WILK'S EXAMPLE

i	a_i	$X^{(n-i+1)} - X^{(i)}$	
1	0.4734	0.365	$X^{(20)} - X^{(1)}$
2	0.3211	0.338	$X^{(19)} - X^{(2)}$
3	0.2565	0.293	$X^{(18)} - X^{(3)}$
4	0.2085	0.235	$X^{(17)} - X^{(4)}$
5	0.1686	0.194	$X^{(16)} - X^{(5)}$
6	0.1334	0.163	$X^{(15)} - X^{(6)}$
7	0.1013	0.130	$X^{(14)} - X^{(7)}$
8	0.0711	0.097	$X^{(13)} - X^{(8)}$
9	0.0422	0.012	$X^{(12)} - X^{(9)}$
10	0.0140	0.012	$X^{(11)} - X^{(10)}$

12.13.2.6.6 Compute the test statistic, W , as follows:

$$W = \frac{1}{D} \left[\sum_{i=1}^k a_i (X^{(n-i+1)} - X^{(i)}) \right]^2$$

The differences $X^{(n-i+1)} - X^{(i)}$ are listed in Table 6. For the data in this example,

$$W = \frac{1}{0.2428} (0.4807)^2 = 0.952$$

12.13.2.6.7 The decision rule for this test is to compare W as calculated in Section 13.2.6.6 to a critical value found in Table 6, Appendix B. If the computed W is less than the critical value, conclude that the data are not normally distributed. For the data in this example, the critical value at a significance level of 0.01 and $n = 20$ observations is 0.868. Since $W = 0.952$ is greater than the critical value, conclude that the data are normally distributed.

12.13.2.7 Test for Homogeneity of Variance

12.13.2.7.1 The test used to examine whether the variation in mean proportion mortality is the same across all toxicant concentrations including the

control), is Bartlett's Test (Snedecor and Cochran, 1980). The test statistic is as follows:

$$B = \frac{[(\sum_{i=1}^p V_i) \ln \bar{S}^2 - \sum_{i=1}^p V_i \ln S_i^2]}{C}$$

Where: V_i = degrees of freedom for each copper concentration and control, $V_i = (n_i - 1)$

p = number of concentration levels including the control

\ln = \log_e

i = 1, 2, ..., p where p is the number of concentrations including the control

n_i = the number of replicates for concentration i .

$$\bar{S}^2 = \frac{(\sum_{i=1}^p V_i S_i^2)}{\sum_{i=1}^p V_i}$$

$$C = 1 + [3(p-1)]^{-1} [\sum_{i=1}^p i/V_i - (\sum_{i=1}^p V_i)^{-1}]$$

12.13.2.7.2 Since B is approximately distributed as chi-square with $p - 1$ degrees of freedom when the variances are equal, the appropriate critical value is obtained from a table of the chi-square distribution for $p - 1$ degrees of freedom and a significance level of 0.01. If B is less than the critical value then the variances are assumed to be equal.

12.13.2.7.3 For the data in this example, $V_i = 3$, $p = 5$, $\bar{S}^2 = 0.0162$, and $C = 1.133$. The calculated B value is:

$$\begin{aligned} B &= \frac{(15) [\ln(0.0162)] - 3 \sum_{i=1}^5 \ln(S_i^2)}{1.33} \\ &= \frac{15(-4.1227) - 3(-20.9485)}{1.33} \\ &= 0.886 \end{aligned}$$

12.13.2.7.4 Since B is approximately distributed as chi-square with p - 1 degrees of freedom when the variances are equal, the appropriate critical value for the test is 13.277 for a significance level of 0.01. Since B = 0.886 is less than the critical value of 13.277, conclude that the variances are not different.

12.13.2.8 Dunnett's Procedure

12.13.2.8.1 To obtain an estimate of the pooled variance for the Dunnett's Procedure, construct an ANOVA table as described in Table 7.

TABLE 7. ANOVA TABLE

Source	df	Sum of Squares (SS)	Mean Square (MS) (SS/df)
Between	p - 1	SSB	$S_B^2 = SSB/(p-1)$
Within	N - p	SSW	$S_W^2 = SSW/(N-p)$
Total	N - 1	SST	

Where: p = number of SDS concentration levels including the control

N = total number of observations $n_1 + n_2 \dots + n_p$

n_i = number of observations in concentration i

$$SSB = \sum_{i=1}^p T_i^2/n_i - G^2/N \quad \text{Between Sum of Squares}$$

$$SST = \sum_{i=1}^p \sum_{j=1}^{n_i} Y_{ij}^2 - G^2/N \quad \text{Total Sum of Squares}$$

$$SSW = SST - SSB \quad \text{Within Sum of Squares}$$

G = the grand total of all sample observations, $G = \sum_{i=1}^p T_i$

T_i = the total of the replicate measurements for concentration i

Y_{ij} = the j th observation for concentration i (represents the proportion surviving for toxicant concentration i in test chamber j)

12.13.2.8.2 For the data in this example:

$$n_1 = n_2 = n_3 = n_4 = n_5 = 4$$

$$N = 20$$

$$T_1 = Y_{11} + Y_{12} + Y_{13} + Y_{14} = 0.962$$

$$T_2 = Y_{21} + Y_{22} + Y_{23} + Y_{24} = 1.409$$

$$T_3 = Y_{31} + Y_{32} + Y_{33} + Y_{34} = 1.267$$

$$T_4 = Y_{41} + Y_{42} + Y_{43} + Y_{44} = 2.051$$

$$T_5 = Y_{51} + Y_{52} + Y_{53} + Y_{54} = 4.454$$

$$G = T_1 + T_2 + T_3 + T_4 = 10.143$$

$$SSB = \sum_{i=1}^p T_i^2/n_i - G^2/N$$

$$= \frac{1}{4} (28.561) - \frac{(10.143)^2}{20} = 1.996$$

$$SST = \sum_{i=1}^p \sum_{j=1}^{n_i} Y_{ij}^2 - G^2/N$$

$$= 7.383 - \frac{(10.143)^2}{20} = 2.239$$

$$SSW = SST - SSB = 2.239 - 1.996 = 0.243$$

$$S_w^2 = SSB/(p-1) = 1.996/(5-1) = 0.499$$

$$S_w^2 = SSW/(N-p) = 0.243/(20-5) = 0.016$$

12.13.2.8.3 Summarize these calculations in the ANOVA table (Table 8).

TABLE 8. ANOVA TABLE FOR DUNNETT'S PROCEDURE EXAMPLE

Source	df	Sum of Squares (SS)	Mean Square (MS) (SS/df)
Between	4	1.996	0.499
Within	15	0.243	0.016
Total	19	2.239	

12.13.2.8.4 To perform the individual comparisons, calculate the t statistic for each concentration, and control combination as follows:

$$t_i = \frac{(\bar{Y}_1 - \bar{Y}_i)}{S_w \sqrt{(1/n_1) + (1/n_i)}}$$

Where: \bar{Y}_i = mean proportion surviving for concentration i

\bar{Y}_1 = mean proportion surviving for the control

S_w = square root of the within mean square

n_1 = number of replicates for the control

n_i = number of replicates for concentration i.

Since we are looking for an increased response in percent of total mortality over control, the control mean is subtracted from the mean at a concentration.

12.13.2.8.5 Table 9 includes the calculated t values for each concentration and control combination. In this example, comparing the 0.5 mg/L concentration with the control the calculation is as follows:

$$t_2 = \frac{(0.352 - 0.241)}{[0.1265\sqrt{(1/4) + (1/4)}]} = 1.241$$

12.13.2.8.6 Since the purpose of this test is to detect a significant increase in total mortality, a one-sided test is appropriate. The critical value for this one-sided test is found in Table 5, Appendix C. For an overall alpha level of 0.05, 15 degrees of freedom for error and four concentrations (excluding the control) the critical value is 2.36. The mean proportion of

TABLE 9. CALCULATED T VALUES

SDS Concentration (mg/L)	i	t _i
0.5	2	1.241
1.0	3	0.850
2.0	4	3.041
4.0	5	9.760

total mortality for concentration "i" is considered significantly less than the mean proportion of total mortality for the control if t_i is greater than the critical value. Therefore, the 2.0 mg/L and the 4.0 mg/L concentrations have significantly higher mean proportions of total mortality than the control. Hence the NOEC is 1.0 mg/L and the LOEC is 2.0 mg/L.

12.13.2.8.7 To quantify the sensitivity of the test, the minimum significant difference (MSD) that can be detected statistically may be calculated.

$$MSD = d S_w \sqrt{(1/n_1) + (1/n)}$$

Where: d = the critical value for Dunnett's procedure

S_w = the square root of the within mean square

n₁ = the number of replicates in the control.

n = The common number of replicates at each concentration (this assumes equal replication at each concentration)

12.13.2.8.8 In this example:

$$\begin{aligned} MSD &= 2.36 (0.1265) \sqrt{(1/4) + (1/4)} \\ &= 2.36 (0.1265)(0.7071) \\ &= 0.211 \end{aligned}$$

12.13.2.8.9 The MSD (0.450) is in transformed units. To determine the MSD in terms of percent survival, carry out the following conversion.

1. Add the MSD to the transformed control mean.

$$0.241 + 0.211 = 0.452$$

2. Obtain the untransformed values for the control mean and the sum calculated in 1.

$$[\text{Sine} (0.241)]^2 = 0.057$$

$$[\text{Sine} (0.452)]^2 = 0.191$$

3. The untransformed MSD (MSD_u) is determined by subtracting the untransformed values from step 2.

$$MSD_u = 0.191 - 0.057 = 0.134$$

12.13.2.8.10 Therefore, for this set of data, the minimum difference in mean proportion of total mortality between the control and any SDS concentration that can be detected as statistically significant is 0.134.

12.13.2.8.11 This represents a 268% increase in mortality from the control.

12.13.2.9 Calculation of the LC50

12.13.2.9.1 The data used for the Probit Analysis is summarized in Table 10. To perform the Probit Analysis, run the USEPA Probit Analysis Program. An example of the program input and output is supplied in Appendix H.

TABLE 10. DATA FOR PROBIT ANALYSIS

	SDS Concentration (mg/L)					
	Control	0.5	1.0	2.0	4.0	8.0
Number Dead	4	4	2	8	32	40
Number Exposed	40	40	40	40	40	40

12.13.2.9.2 For this example, the chi-square test for heterogeneity was not significant. Thus Probit Analysis appears appropriate for this set of data.

12.13.2.9.3 Figure 5 shows the output data for the Probit Analysis of the data from Table 10 using the USEPA Probit Program.

USEPA PROBIT ANALYSIS PROGRAM
 USED FOR CALCULATING LC/EC VALUES
 Version 1.5

Probit Analysis of Sheepshead Minnow Embryo-Larval Survival and Teratogenicity Data

Conc.	Number Exposed	Number Resp.	Observed Proportion Responding	Proportion Responding Adjusted for Controls
Control	40	4	0.1000	0.0000
0.5000	40	4	0.1000	0.0174
1.0000	40	2	0.0500	-.0372
2.0000	40	8	0.2000	0.1265
4.0000	40	32	0.8000	0.7816
8.0000	40	40	1.0000	1.0000

Chi - Square for Heterogeneity (calculated) = 0.883
 Chi - Square for Heterogeneity (tabular value) = 7.815

Probit Analysis of Sheepshead Minnow Embryo-Larval Survival and Teratogenicity Data

Estimated LC/EC Values and Confidence Limits

Point	Exposure Conc.	Lower 95% Confidence	Upper Limits
LC/EC 1.00	1.346	0.751	1.776
LC/EC 50.00	3.018	2.539	3.455

Figure 5. Output for USEPA Probit Program, Version 1.5.

12.14 PRECISION AND ACCURACY

12.14.1 PRECISION

12.14.1.1 Single-Laboratory Precision

12.14.1.1.1 Data on the single-laboratory precision of the sheepshead minnow embryo-larval survival and teratogenicity test are available for eight tests with copper sulfate and five tests with sodium dodecyl sulfate (USEPA, 1989a). The data for the first five tests show that the same NOEC and LOEC, 240 $\mu\text{g Cu/L}$ and 270 $\mu\text{g Cu/L}$, respectively, were obtained in all five tests, which is the maximum level of precision that can be attained. Three additional tests (6-8) were performed with narrower (20 μg) concentration intervals, to more precisely identify the threshold concentration. The NOEC and LOEC for these tests are 200 μg and 220 $\mu\text{g Cu/L}$, respectively. For sodium dodecyl sulfate, the NOEC's and LOEC's for all tests are 2.0 and 4.0 mg/L, respectively. The precision, expressed as the coefficient of variation (CV%), is indicated in Tables 11-12. For copper (Cu), the coefficient of variation, depending on the endpoint used, ranges from 2.5% to 6.1% which indicates excellent precision. For sodium dodecyl sulfate (SDS), the coefficient of variation, depending on the endpoint used, ranges from 11.7% to 51.2%, indicating acceptable precision.

12.14.1.2 Multilaboratory Precision

12.14.1.2.1 Data on the multilaboratory precision of this test are not yet available.

12.14.2 ACCURACY

12.14.2.1 The accuracy of toxicity tests cannot be determined.

TABLE 11. SINGLE-LABORATORY PRECISION OF THE SHEEPSHEAD MINNOW, *CYPRINODON VARIEGATUS*, EMBRYO-LARVAL SURVIVAL AND TERATOGENICITY TEST PERFORMED IN HW MARINEMIX® ARTIFICIAL SEAWATER, USING EMBRYOS FROM FISH MAINTAINED AND SPAWNED IN HW MARINEMIX® ARTIFICIAL SEAWATER USING COPPER (CU) SULFATE AS REFERENCE TOXICANT^{1,2,3,4,5,6,7}

Test Number	EC1 (µg/L)	EC5 (µg/L)	EC10 (µg/L)	EC50 (µg/L)	NOEC (µg/L)
1	173	189	198	234	240
2	*	*	*	*	240
3	*	*	*	*	240
4	182	197	206	240	240
5	171	187	197	234	240
6	*	*	*	*	< 200
7	*	*	*	*	220
8	195	203	208	226	220
n:	4	4	4	4	7
Mean:	180	194	202	233	NA
CV(%):	6.1	3.8	2.8	2.5	NA

- ¹ Data from USEPA (1988a) and USEPA (1991a).
 - ² Tests performed by Terry Hollister, Aquatic Biologist, Houston Facility, Environmental Services Division, Region 6, USEPA, Houston, Texas.
 - ³ *Cyprinodon variegatus* embryos used in the tests were less than 20 h old when the tests began. Two replicate test chambers were used for the control and each toxicant concentration. Ten embryos were randomly added to each test chamber containing 250 mL of test or control water. Solutions were renewed daily. The temperature and salinity of the test solutions were 24 ± 1°C and 20‰, respectively.
 - ⁴ Copper test concentrations were prepared using copper sulfate. Copper concentrations for Tests 1-5 were: 180, 210, 240, 270, and 300 µg/L. Copper concentrations for Test 6 were: 220, 240, 260, 280, and 300 µg/L. Copper concentrations for Tests 7-8 were: 200, 220, 240, 260, and 280 µg/L. Tests were conducted over a two-week period.
 - ⁵ Adults collected in the field.
 - ⁶ NOEC Range: 200 - 240 µg/L (this represents a difference of two exposure concentrations).
 - ⁷ For a discussion of the precision of data from chronic toxicity tests see Section 4, Quality Assurance.
- * = Data did not fit the Probit model.

TABLE 12. SINGLE-LABORATORY PRECISION OF THE SHEEPSHEAD MINNOW, *CYPRINODON VARIEGATUS*, EMBRYO-LARVAL SURVIVAL AND TERATOGENICITY TEST PERFORMED IN HW MARINEMIX® ARTIFICIAL SEAWATER, USING EMBRYOS FROM FISH MAINTAINED AND SPAWNED IN HW MARINEMIX® ARTIFICIAL SEAWATER USING SODIUM DODECYL SULFATE (SDS) AS REFERENCE TOXICANT^{1,2,3,4,5,6,7}

Test Number	EC1 (mg/L)	EC5 (mg/L)	EC10 (mg/L)	EC50 (mg/L)	NOEC (mg/L)
1	1.7	2.0	2.2	3.1	2.0
2	*	*	*	*	4.0
3	0.4	0.7	0.9	2.5	2.0
4	1.9	2.2	2.4	3.3	2.0
5	1.3	1.7	1.9	3.0	2.0
n:	4	4	4	4	5
Mean:	1.3	1.6	1.9	2.9	NA
CV(%):	51.2	41.6	35.0	11.7	NA

¹ Data from USEPA (1988a) and USEPA (1991a).

² Tests performed by Terry Hollister, Aquatic Biologist, Houston Facility, Environmental Services Division, Region 6, USEPA, Houston, Texas.

³ *Cyprinodon variegatus* embryos used in the tests were less than 20 h old when the tests began. Two replicate test chambers were used for the control and each toxicant concentration. Ten embryos were randomly added to each test chamber containing 250 mL of test or control water. Solutions were renewed daily. The temperature and salinity of the test solutions were 24 + 1°C and 20‰, respectively.

⁴ SDS concentrations for all tests were: 0.5, 1.0, 2.0, 4.0, and 8.0 mg/L. Tests were conducted over a three-week period.

⁵ Adults collected in the field.

⁶ NOEC Range: 2.0 - 4.0 mg/L (this represents a difference of two exposure concentrations).

⁷ For a discussion of the precision of data from chronic toxicity tests see Section 4, Quality Assurance.

* = Data did not fit the Probit model.

SECTION 13

TEST METHOD

INLAND SILVERSIDE, *MENIDIA BERYLLINA*, LARVAL SURVIVAL AND GROWTH METHOD 1006.0

13.1 SCOPE AND APPLICATION

13.1.1 This method estimates the chronic toxicity of effluents and receiving waters to the inland silverside, *Menidia beryllina*, using seven-to-eleven day old larvae in a seven day, static renewal test. The effects include the synergistic, antagonistic, and additive effects of all the chemical, physical, and biological components which adversely affect the physiological and biochemical functions of the test species.

13.1.2 Daily observations on mortality make it possible to also calculate acute toxicity for desired exposure periods (i.e., 24-h, 48-h, 96-h LC50s).

13.1.3 Detection limits of the toxicity of an effluent or chemical substance are organism dependent.

13.1.4 Brief excursions in toxicity may not be detected using 24-h composite samples. Also, because of the long sample collection period involved in composite sampling, and because the test chambers are not sealed, highly volatile and highly degradable toxicants present in the source may not be detected in the test.

13.1.5 This test is commonly used in one of two forms: (1) a definitive test, consisting of a minimum of five effluent concentrations and a control, and (2) a receiving water test(s), consisting of one or more receiving water concentrations and a control.

13.2 SUMMARY OF METHOD

13.2.1 Inland silverside, *Menidia beryllina*, 7 to 11-d old larvae are exposed in a static renewal system for seven days to different concentrations of effluent or to receiving water. Test results are based on the survival and growth of the larvae.

13.3 INTERFERENCES

13.3.1 Toxic substances may be introduced by contaminants in dilution water, glassware, sample hardware, and testing equipment (see Section 5, Facilities, Equipment, and Supplies).

13.3.2 Adverse effects of low dissolved oxygen (DO) concentrations, high concentrations of suspended and/or dissolved solids, and extremes of pH, may mask or confound the effects of toxic substances.

13.3.3 Improper effluent sampling and handling may adversely affect test results (see Section 8, Effluent and Receiving Water Sampling, Sample Handling, and Sample Preparation for Toxicity Tests).

13.3.4 Pathogenic and/or predatory organisms in the dilution water and effluent may affect test organism survival, and confound test results.

13.3.5 Food added during the test may sequester metals and other toxic substances and confound test results.

13.4 SAFETY

13.4.1 See Section 3, Health and Safety.

13.5 APPARATUS AND EQUIPMENT

13.5.1 Facilities for holding and acclimating test organisms.

13.5.2 Brine shrimp, *Artemia*, culture unit -- see Subsection 13.6.16 below and Section 4, Quality Assurance.

13.5.3 *Menidia beryllina* culture unit -- see Subsection 13.6.17 below, Middaugh and Hemmer (1984), Middaugh et al. (1986), USEPA (1987g) and USEPA (1993a) for detailed culture methods. This test requires from 180 to 360 7 to 11 day-old larvae. It is preferable to obtain the test organisms from an in-house culture unit. If it is not feasible to culture fish in-house, embryos or larvae can be obtained from other sources by shipping them in well oxygenated saline water in insulated containers.

13.5.4 Samplers -- automatic sampler, preferably with sample cooling capability, that can collect a 24-h composite sample of 5 L.

13.5.5 Environmental chamber or equivalent facility with temperature control ($25 \pm 1^\circ\text{C}$).

13.5.6 Water purification system -- Millipore Milli-Q®, deionized water (DI) or equivalent.

13.5.7 Balance, analytical -- capable of accurately weighing to 0.00001 g.

13.5.8 Reference weights, Class S -- for checking performance of balance. Weights should bracket the expected weights of the weighing pans and the expected weights of the weighing pans plus fish.

13.5.9 Drying oven -- 50-105°C range, for drying larvae.

13.5.10 Air pump -- for oil-free air supply.

13.5.11 Air lines, plastic or pasteur pipettes, or air stones -- for gently aerating water containing the fragile larvae or for supplying air to test solution with low DO.

- 13.5.12 Meters, pH and DO -- for routine physical and chemical measurements.
- 13.5.13 Standard or micro-Winkler apparatus -- for calibrating DO (optional).
- 13.5.14 Desiccator -- for holding dried larvae.
- 13.5.15 Light box -- for counting and observing larvae.
- 13.5.16 Refractometer -- for determining salinity.
- 13.5.17 Thermometers, glass or electronic, laboratory grade -- for measuring water temperatures.
- 13.5.18 Thermometers, bulb-thermograph or electronic chart type -- for continuously recording temperature.
- 13.5.19 Thermometer, National Bureau of Standards Certified (see USEPA Method 170.1, USEPA, 1979b) -- to calibrate laboratory thermometers.
- 13.5.20 Test chambers -- four (minimum of three) chambers per concentration. The chambers should be borosilicate glass or nontoxic disposable plastic labware. To avoid potential contamination from the air and excessive evaporation of test solutions during the test, the chambers should be covered during the test with safety glass plates or sheet plastic (6 mm thick).
- 13.5.20.1 Each test chamber for the inland silverside should contain a minimum of 750 mL of test solution. A modified Norberg and Mount (1985) chamber (Figure 1), constructed of glass and silicone cement, has been used successfully for this test. This type of chamber holds an adequate column of test solution and incorporates a sump area from which test solutions can be siphoned and renewed without disturbing the fragile inland silverside larvae. Modifications for the chamber are as follows: 1) 200 μ m mesh NITEX[®] screen instead of stainless steel screen; and 2) thin pieces of glass rods cemented with silicone to the NITEX[®] screen to reinforce the bottom and sides to produce a sump area in one end of the chamber. Avoid excessive use of silicone, while still ensuring that the chambers do not leak and the larvae cannot get trapped or escape into the sump area. Once constructed, check the chambers for leaks and repair if necessary. Soak the chambers overnight in seawater (preferably in flowing water) to cure the silicone cement before use. Other types of glass test chambers, such as the 1000 mL beakers used in the short-term sheepshead minnow larval survival and growth test, may be used. It is recommended that each chamber contain a minimum of 50 mL per larvae and allow adequate depth of test solution (5.0 cm).
- 13.5.21 Beakers -- six Class A, borosilicate glass or non-toxic plasticware, 1000 mL for making test solutions.
- 13.5.22 Mini-Winkler bottles -- for dissolved oxygen calibrations.
- 13.5.23 Wash bottles -- for deionized water, for washing embryos from substrates and containers, and for rinsing small glassware and instrument electrodes and probes.

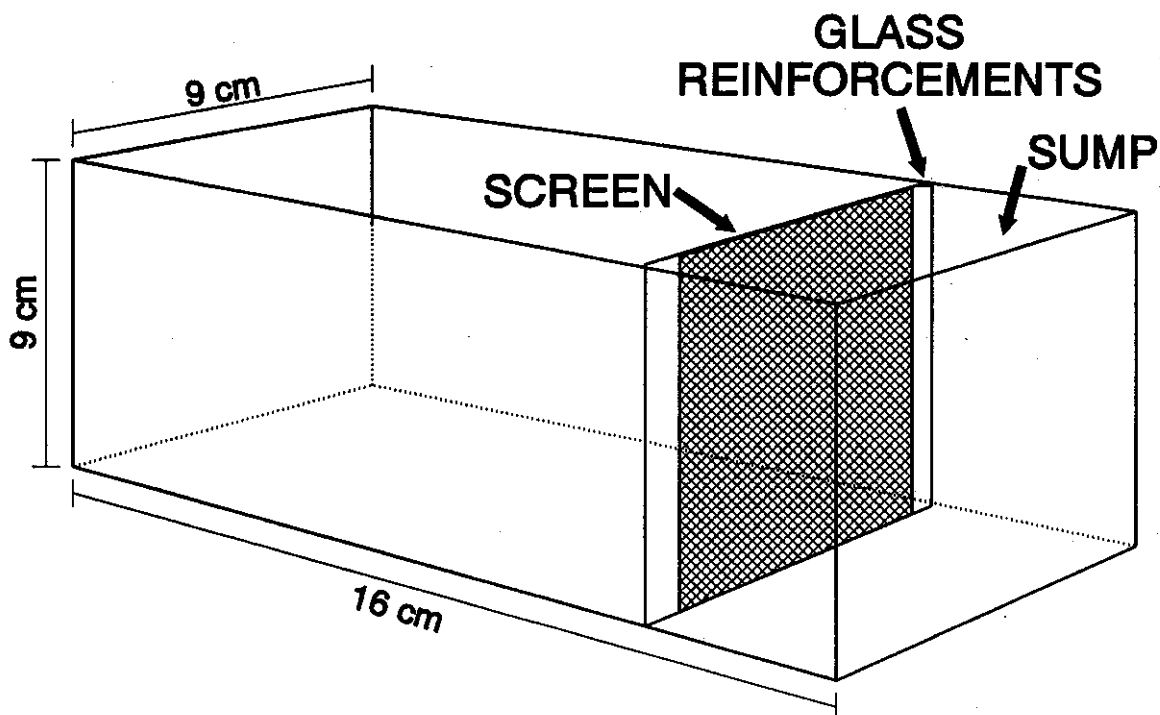

Figure 1. Glass chamber with sump area. Modified from Norberg and Mount (1985). From USEPA (1987c).

13.5.24 Crystallization dishes, beakers, culture dishes, or equivalent -- for incubating embryos.

13.5.25 Volumetric flasks and graduated cylinders -- Class A, borosilicate glass or non-toxic plastic labware, 10-1000 mL for making test solutions.

13.5.26 Separatory funnels, 2-L -- Two-four for culturing *Artemia*.

13.5.27 Pipets, volumetric -- Class A, 1-100 mL.

13.5.28 Pipets, automatic -- adjustable, 1-100 mL.

13.5.29 Pipets, serological -- 1-10 mL, graduated.

13.5.30 Pipet bulbs and fillers -- PROPIPET®, or equivalent.

13.5.31 Droppers, and glass tubing with fire polished edges, 4 mm ID -- for transferring larvae.

13.5.32 Siphon with bulb and clamp -- for cleaning test chambers.

13.5.33 Forceps -- for transferring dead larvae to weighing pans.

13.5.34 NITEX® mesh sieves ($\leq 150 \mu\text{m}$, $500 \mu\text{m}$, 3 to 5 mm) -- for collecting *Artemia* nauplii and fish larvae. (NITEX® is available from Sterling Marine Products, 18 Label Street, Montclair, NJ 07042; 201-783-9800.)

13.6 REAGENTS AND CONSUMABLE MATERIALS

13.6.1 Sample containers -- for sample shipment and storage (see Section 8, Effluent and Receiving Water Sampling, Sample Handling, and Sample Preparation for Toxicity Tests).

13.6.2 Data sheets (one set per test) -- for data recording.

13.6.3 Tape, colored -- for labelling test chambers.

13.6.4 Markers, waterproof -- for marking containers, etc.

13.6.5 Vials, marked -- 24/test, containing 4% formalin or 70% ethanol, to preserve larvae (optional).

13.6.6 Weighing pans, aluminum -- 26/test (2 extra).

13.6.7 Buffers, pH 4, pH 7, and pH 10 (or as per instructions of instrument manufacturer) for standards and calibration check (see USEPA Method 150.1, USEPA, 1979b).

13.6.8 Membranes and filling solutions for dissolved oxygen probe (see USEPA Method 360.1, USEPA, 1979b), or reagents -- for modified Winkler analysis.

13.6.9 Laboratory quality assurance samples and standards -- for the above methods.

13.6.10 Reference toxicant solutions -- see Section 4, Quality Assurance.

13.6.11 Ethanol (70%) or formalin (4%) -- for use as a preservative for the fish larvae.

13.6.12 Reagent water -- defined as distilled or deionized water that does not contain substances which are toxic to the test organisms (see Section 5, Facilities, Equipment, and Supplies).

13.6.13 Effluent, receiving water, and dilution water -- see Section 7, Dilution Water; and Section 8, Effluent and Surface Water Sampling, Sample Handling, and Sample Preparation for Toxicity Tests.

13.6.13.1 Saline test and dilution water -- the salinity of the test water must be in the range of 5 to 32‰. The salinity should vary by no more than $\pm 2\%$ among the chambers on a given day. If effluent and receiving water tests are conducted concurrently, the salinities of these tests should be similar.

13.6.13.2 The overwhelming majority of industrial and sewage treatment effluents entering marine and estuarine systems contain little or no

measurable salts. Exposure of *Menidia beryllina* larvae to these effluents will require adjustments in the salinity of the test solutions. It is important to maintain a constant salinity across all treatments. In addition, it may be desirable to match the test salinity with that of the receiving water. Artificial sea salts or hypersaline brine (100‰) derived from natural seawater may be used to adjust the salinities.

13.6.13.3 Hypersaline brine (HSB): HSB has several advantages that make it desirable for use in toxicity testing. It can be made from any high quality, filtered seawater by evaporation, and can be added to the effluent or to deionized water to increase the salinity. HSB derived from natural seawater contains the necessary trace metals, biogenic colloids, and some of the microbial components necessary for adequate growth, survival, and/or reproduction of marine and estuarine organisms, and may be stored for prolonged periods without any apparent degradation. However, if 100% HSB is used as a diluent, the maximum concentration of effluent that can be tested will be 70% at 30‰ salinity and 80% at 20‰ salinity.

13.6.13.3.1 The ideal container for making HSB from natural seawater is one that (1) has a high surface to volume ratio, (2) is made of a noncorrosive material, and (3) is easily cleaned (fiberglass containers are ideal). Special care should be used to prevent any toxic materials from coming in contact with the seawater being used to generate the brine. If a heater is immersed directly into the seawater, ensure that the heater materials do not corrode or leach any substances that would contaminate the brine. One successful method used is a thermostatically controlled heat exchanger made from fiberglass. If aeration is used, use only oil free air compressors to prevent contamination.

13.6.13.3.2 Before adding seawater to the brine generator, thoroughly clean the generator, aeration supply tube, heater, and any other materials that will be in direct contact with the brine. A good quality biodegradable detergent should be used, followed by several (at least three) thorough deionized water rinses.

13.6.13.3.3 High quality (and preferably high salinity) seawater should be filtered to at least 10 μm before placing into the brine generator. Water should be collected on an incoming tide to minimize the possibility of contamination.

13.6.13.3.4 The temperature of the seawater is increased slowly to 40°C. The water should be aerated to prevent temperature stratification and to increase water evaporation. The brine should be checked daily (depending on volume being generated) to ensure that salinity does not exceed 100‰ and that the temperature does not exceed 40°C. Additional seawater may be added to the brine to obtain the volume of brine required.

13.6.13.3.5 After the required salinity is attained, the HSB should be filtered a second time through a 1 μm filter and poured directly into portable containers (20 L cubitainers or polycarbonate water cooler jugs are suitable). The containers should be capped and labelled with the date the brine was

generated and its salinity. Containers of HSB should be stored in the dark and maintained at room temperature until used.

13.6.13.3.6 If a source of HSB is available, test solutions can be made by following the directions below. Thoroughly mix together the deionized water and brine before mixing in the effluent.

13.6.13.3.7 Divide the salinity of the HSB by the expected test salinity to determine the proportion of deionized water to brine. For example, if the salinity of the HSB is 100‰ and the test is to be conducted at 20‰, $100‰ \div 20‰ = 5.0$. The proportion of brine is one part in five (one part brine to four parts deionized water). To make 1 L of seawater at 20‰ salinity from a HSB of 100‰, divide 1 L (1000 mL) by 5.0. The result, 200 mL, is the quantity of HSB needed to make 1 L of seawater. The difference, 800 mL, is the quantity of deionized water required.

13.6.13.3.8 Table 1 illustrates the composition of test solutions at 20‰ if they are made by combining effluent (0‰), deionized water and HSB at 100‰ salinity. The volume (mL) of brine required is determined by using the amount calculated above. In this case, 200 mL of brine is required for 1 L; therefore, 600 mL would be required for 3 L of solution. The volumes of HSB required are constant. The volumes of deionized water are determined by subtracting the volumes of effluent and brine from the total volume of solution: $3,000 \text{ mL} - \text{mL effluent} - \text{mL HSB} = \text{mL deionized water}$.

13.6.13.4 Artificial sea salts: A modified GP2 artificial seawater formulation (Table 2) has been successfully used to perform the inland silverside survival and growth test. The use of GP2 for holding and culturing of adults is not recommended at this time.

13.6.13.4.1 The GP2 artificial sea salts (Table 2) should be mixed with deionized (DI) water or its equivalent in a container other than the culture or testing tanks. The deionized water used for hydration should be between 21-26°C. The artificial seawater must be conditioned (aerated) for 24 h before use as the testing medium. If the solution is to be autoclaved, sodium bicarbonate is added after the solution has cooled. A stock solution of sodium bicarbonate is made up by dissolving 33.6 gm NaHCO_3 in 500 mL deionized water. Add 2.5 mL of this stock solution for each liter of the GP2 artificial seawater.

13.6.14 ROTIFER CULTURE --for feeding cultures and test organisms

13.6.14.1 At hatching *Menidia beryllina* larvae are too small to ingest *Artemia* nauplii and must be fed rotifers, *Brachionus plicatilis*. The rotifers can be maintained in continuous culture when fed algae (see Section 6 and USEPA, 1987g). Rotifers are cultured in 10-15 L Pyrex® carboys (with a drain spigot near the bottom) at 25-28°C and 25-35‰ salinity. Four 12-L culture carboys should be maintained simultaneously to optimize production. Clean carboys should be filled with autoclaved seawater. Alternatively, an immersion heater may be used to heat saline water in the carboy to 70-80°C for 1 h.

TABLE 1. PREPARATION OF 3 L SALINE WATER FROM DEIONIZED WATER AND A HYPERSALINE BRINE OF 100‰ NEEDED FOR TEST SOLUTIONS AT 20‰ SALINITY

Effluent Concentration (%)	Volume of Effluent (‰) (mL)	Volume of Deionized Water (mL)	Volume of Hypersaline Brine (mL)	Total Volume (mL)
80	2400	0	600	3000
40	1200	1200	600	3000
20	600	1800	600	3000
10	300	2100	600	3000
5	150	2250	600	3000
Control	0	2400	600	3000
Total	4,650	9,750	3,600	18,000

TABLE 2. REAGENT GRADE CHEMICALS USED IN THE PREPARATION OF GP2 ARTIFICIAL SEAWATER FOR THE INLAND SILVERSIDE, *MENIDIA BERYLLINA*, TOXICITY TEST^{1,2,3}

Compound	Concentration (g/L)	Amount (g) Required for 20 L
NaCl	21.03	420.6
Na ₂ SO ₄	3.52	70.4
KCl	0.61	12.2
KBr	0.088	1.76
Na ₂ B ₄ O ₇ · 10 H ₂ O	0.034	0.68
MgCl ₂ · 6 H ₂ O	9.50	190.0
CaCl ₂ · 2 H ₂ O	1.32	26.4
SrCl ₂ · 6 H ₂ O	0.02	0.400
NaHCO ₃	0.17	3.40

¹ Modified GP2 from Spotte et al. (1984)

² The constituent salts and concentrations were taken from USEPA (1990b). The salinity is 30.89 g/L.

³ GP2 can be diluted with deionized (DI) water to the desired test salinity.

13.6.14.2 When the water has cooled to 25-28°C, aerate and add a start-up sample of rotifers (50 rotifers/mL) and food (about 1 L of a dense algal culture). The carboys should be checked daily to ensure that adequate food is available and that the rotifer density is adequate. If the water appears clear, drain 1 L of culture water and replace it with algae. Excess water can be removed through the spigot drain and filtered through a $\leq 60 \mu\text{m}$ mesh screen. Rotifers collected on the screen should be returned to the culture. If a more precise measure of the rotifer population is needed, rotifers collected from a known volume of water can be resuspended in a smaller volume, killed with formalin and counted in a Sedgwick-Rafter cell. If the density exceeds 50 rotifers/mL, the amount of food per day should be increased to 2 L of algae suspension. The optimum density of approximately 300-400 rotifers/mL may be reached in 7-10 days and is sustainable for 2-3 weeks. At these densities, the rotifers should be cropped daily. Keeping the carboys away from light will reduce the amount of algae attached to the carboy walls. When detritus accumulates, populations of ciliates, nematodes, or harpacticoid copepods that may have been inadvertently introduced can rapidly take over the culture. If this occurs, discard the cultures.

13.6.15 ALGAL CULTURES -- for feeding rotifer cultures

13.6.15.1 *Tetraselmus suecica* or *Chlorella* sp. (see USEPA, 1987a) can be cultured in 20-L polycarbonate carboys that are normally used for bottled drinking water. Filtered seawater is added to the carboys and then autoclaved (110°C for 30 min). After cooling to room temperature, the carboys are placed in a temperature chamber controlled at 18-20°C. One liter of *T. suecica* or *Chlorella* sp. starter culture and 100 mL of nutrients are added to each carboy.

13.6.15.2 Formula for algal culture nutrients.

13.6.15.2.1 Add 180 g NaNO_3 , 12 g NaH_2PO_4 , and 6.16 g EDTA to 12 L of deionized water. Mix with a magnetic stirrer until all salts are dissolved (at least 1 h).

13.6.15.2.2 Add 3.78 g $\text{FeCl}_3 \cdot 6 \text{H}_2\text{O}$ and stir again. The solution should be bright yellow.

13.6.15.2.3 The algal culture is vigorously aerated via a pipette inserted through a foam stopper at the top of the carboy. A dense algal culture should develop in 7-10 days and should be used by day 14. Thus, start-up of cultures should be made on a daily or every second day basis. Approximately 6-8 continuous cultures will meet the feeding requirements of four 12-L rotifer cultures. When emptied, carboys are washed with soap and water and rinsed thoroughly with deionized water before reuse.

13.6.16 BRINE SHRIMP, ARTEMIA, NAUPLII -- for feeding cultures and test organisms

13.6.16.1 Newly hatched *Artemia* nauplii are used as food for inland silverside larvae in toxicity tests. Although there are many commercial sources of brine shrimp cysts, the Brazilian or Colombian strains are being

used because the supplies examined have had low concentrations of chemical residues and produce nauplii of suitably small size. For commercial sources of brine shrimp, *Artemia*, cysts, see Table 2 of Section 5, Facilities, Equipment, and Supplies and Section 4, Quality Assurance.

13.6.16.2 Each new batch of *Artemia* cysts must be evaluated for size (Vanhaecke and Sorgeloos, 1980, and Vanhaecke et al., 1980) and nutritional suitability (see Leger et al., 1985; Leger et al., 1986) against known suitable reference cysts by performing a side by side larval growth test using the "new" and "reference" cysts. The "reference" cysts used in the suitability test may be a previously tested and acceptable batch of cysts, or may be obtained from the Quality Assurance Research Division, Environmental Monitoring Systems Laboratory, Cincinnati, OH 45268; 513-569-7325. A sample of newly-hatched *Artemia* nauplii from each new batch of cysts should be chemically analyzed. The *Artemia* cysts should not be used if the concentration of total organochlorine pesticides exceeds 0.15 $\mu\text{g/g}$ wet weight or that the total concentration of organochlorine pesticides plus PCBs does not exceed 0.30 $\mu\text{g/g}$ wet weight. (For analytical methods, see USEPA 1982).

13.6.16.2.1 *Artemia* nauplii are obtained as follows:

1. Add 1 L of seawater, or a solution prepared by adding 35.0 g uniodized salt (NaCl) or artificial sea salts to 1 L of deionized water, to a 2-L separatory funnel or equivalent.
2. Add 10 mL *Artemia* cysts to the separatory funnel and aerate for 24 h at 27°C. (Hatching time varies with incubation temperature and the geographic strain of *Artemia* used (see USEPA, 1985d; USEPA, 1993a; and ASTM, 1993.)
3. After 24 h, cut off the air supply in the separatory funnel. *Artemia* nauplii are phototactic and will concentrate at the bottom of the funnel if it is covered for 10-15 minutes to prevent mortality, do not leave the concentrated nauplii at the bottom of the funnel more than 10 minutes without aeration.
4. Drain the nauplii into a beaker or funnel fitted with $\leq 150 \mu\text{m}$ NITEX® or stainless steel screen, and rinse with seawater or equivalent before use.

13.6.16.3 Testing *Artemia* nauplii as food for toxicity test organisms.

13.6.16.3.1 The primary criterion for acceptability of each new supply of brine shrimp cysts is the ability of the nauplii to support good survival and growth of the inland silverside larvae (see Subsection 13.11). The larvae used to evaluate the suitability of the brine shrimp nauplii must be of the same geographical origin, species, and stage of development as those used routinely in the toxicity tests. Sufficient data to detect differences in survival and growth should be obtained by using three replicate test chambers each containing a minimum of 15 larvae, for each type of food.

13.6.16.3.2 The feeding rate and frequency, test vessels and volume of control water, duration of the test, and age of the nauplii at the start of the test, should be the same as used for the routine toxicity tests.

13.6.16.3.3 Results of the brine shrimp nutrition assay, where there are only two treatments, can be evaluated statistically by use of a t test. The "new" food is acceptable if there are no statistically significant differences in the survival and growth of the larvae fed the two sources of nauplii.

13.6.16.4 Use of *Artemia* nauplii as food for inland silverside, *Menidia beryllina*, larvae.

13.6.16.4.1 *Menidia beryllina* larvae begin feeding on newly hatched *Artemia* nauplii about five days after hatching, and are fed *Artemia* nauplii daily throughout the 7-day larval survival and growth test. Survival of *Menidia beryllina* larvae 7-9 days old is improved by feeding newly hatched (< 24 h old) *Artemia* nauplii. Equal amounts of *Artemia* nauplii must be fed to each replicate test chamber to minimize the variability of larval weight. Sufficient numbers of nauplii should be fed to ensure that some remain alive overnight in the test chambers. An adequate but not excessive amount should be provided to each replicate on a daily basis. Feeding excessive amounts of nauplii will result in a depletion in DO to below an acceptable level (below 4.0 mg/L). As much of the uneaten *Artemia* nauplii as possible should be siphoned from each chamber prior to test solution renewal to ensure that the larvae principally eat newly hatched nauplii.

13.6.17 TEST ORGANISMS, INLAND SILVERSIDE, *MENIDIA BERYLLINA*

13.6.17.1 The inland silverside, *Menidia beryllina*, is one of three species in the atherinid family that are amenable to laboratory culture; and one of four atherinid species used for chronic toxicity testing. Several atherinid species have been utilized successfully for early life stage toxicity tests using field collected (Goodman et al., 1985) and laboratory reared adults (Middaugh and Takita, 1983; Middaugh and Hemmer, 1984; and USEPA, 1987g). The inland silverside, *Menidia beryllina*, populates a variety of habitats from Cape Cod, Massachusetts, to Florida and west to Vera Cruz, Mexico (Johnson, 1975). It can tolerate a wide range of temperature, 2.9 - 32.5°C (Tagatz and Dudley, 1961; Smith, 1971) and salinity, of 0‰ - 58‰ (Simmons, 1957; Renfro, 1960), having been reported from the freshwaters of the Mississippi River drainage basin (Chernoff et al., 1981) to hypersaline lagoons (Simmons, 1957). Ecologically, *Menidia* spp. are important as major prey for many prominent commercial species (e.g., bluefish (*Pomatomus saltatrix*), mackerel (*Scomber scombrus*), and striped bass (*Morone saxatilis*) (Bigelow and Schroeder, 1953). The inland silverside, *Menidia beryllina*, is a serial spawner, and will spawn under controlled laboratory conditions. Spawning can be induced by diurnal interruption in the circulation of water in the culture tanks (Middaugh et al., 1986; USEPA, 1987a). The eggs are demersal, approximately 0.75 mm in diameter (Hildebrand and Schroeder, 1928), and adhere to vegetation in the wild, or to filter floss in laboratory culture tanks. The larvae hatch in 6-7 days when incubated at 25°C and maintained in seawater ranging from 5‰ to 30‰ (USEPA, 1987a). Newly hatched larvae are 3.5-4.0 mm in total length (Hildebrand, 1922).

13.6.17.2 Inland silverside, *Menidia beryllina*, adults (see USEPA, 1987g and USEPA, 1993a for detailed culture methods) may be cultured in the laboratory or obtained from the Gulf of Mexico or Atlantic coast estuaries throughout the

year (Figure 2). Gravid females can be collected from low salinity waters along the Atlantic coast during April to July, depending on the latitude. The most productive and protracted spawning stock can be obtained from adults brought into the laboratory. Broodstocks, collected from local estuaries twice each year (in April and October), will become sexually active after 1-2 months and will generally spawn for 4-6 months.

13.6.17.3 The fish can be collected easily with a beach seine (3-6 mm mesh), but the seine should not be completely landed onto the beach. Silversides are very sensitive to handling and should never be removed from the water by net -- only by beaker or bucket.

13.6.17.4 Samples may contain a mixture of inland silverside, *Menidia beryllina*, and Atlantic silverside, *Menidia menidia*, on the Atlantic coast or inland silverside and tidewater silverside, *Menidia peninsulae*, on the Gulf Coast (see USEPA, 1987g for additional information on morphological differences for identification). Johnson (1975) and Chernoff et al. (1981) have attempted to differentiate these species. In the northeastern United States, *M. beryllina* juveniles and adults are usually considerably smaller than *M. menidia* juveniles and adults (Bengtson, 1984), and can be separated easily in the field on that basis.

13.6.17.5 Record the water temperature and salinity at each collection site. Aerate (portable air pump, battery operated) the fish and transport to the laboratory as quickly as possible after collection. Upon arrival at the laboratory, the fish and the water in which they were collected are transferred to a tank at least 0.9 m in diameter. A filter system should be employed to maintain water quality (see USEPA, 1987g). Laboratory water is added to the tank slowly, and the fish are acclimated at the rate of 2°C per day, to a final temperature of 25°C, and about 5‰ salinity per day, to a final salinity in the range of 20‰ - 32‰. The seawater in each tank should be brought to a minimum volume of 150 L. A density of about 50 fish/tank is appropriate. Maintain a photoperiod of 16 h light/8 h dark. Feed the adult fish flake food or frozen brine shrimp twice daily and *Artemia* nauplii once daily. Siphon the detritus from the bottom of the tanks weekly.

13.6.17.6 Larvae for a toxicity test can be obtained from the broodstock by spawning onto polyester aquarium filter-fiber substrates, 15 cm long X 10 cm wide X 10 cm thick, which are suspended with a string 8-10 cm below the surface of the water and in contact with the side of the holding tanks for 24-48 h, 14 days prior to the beginning of a test. The floss should be gently aerated by placing it above an airstone, and weighted down with a heavy non-toxic object. The embryos, which are light yellow in color, can be seen on the floss, and are round and hard to the touch compared to the soft floss.

13.6.17.7 Remove as much floss as possible from the embryos. The floss should be stretched and teased to prevent the embryos from clumping. The embryos should be incubated at the test salinity and lightly aerated. At 25°C, the embryos will hatch in about 6-8 days. Larvae are fed about 500 rotifer larvae/day from hatch through four days post-hatch. On Days 5 and 6, newly hatched (less than 12-h old) *Artemia* nauplii are mixed with the

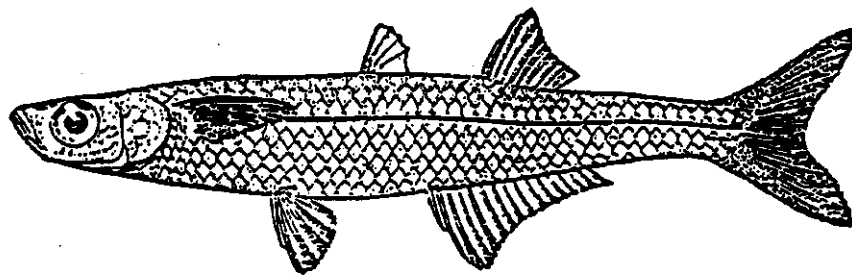

A. Adult, ca. 64 mm SL

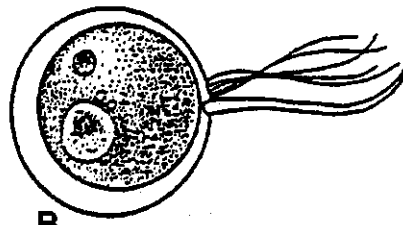

B

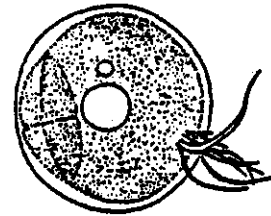

C

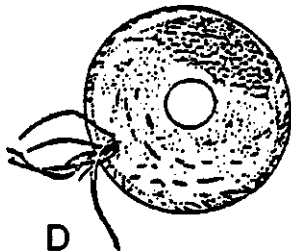

D

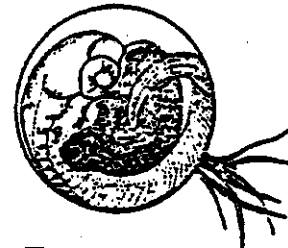

E



F. Larva, 6.7 mm TL

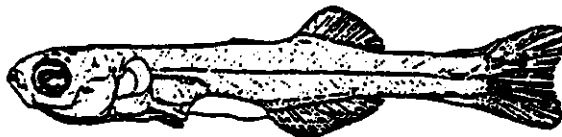

G. Larva, 8.9 mm TL

Figure 2. Inland silverside, *Menidia beryllina*: A. Adult, ca. 64 mm SL; B. Egg (diagrammatic), only bases of filaments shown; C. Egg, 2-cell stage; D. Egg, morula stage; E. Advanced embryo, 2 1/2 days after fertilization. From Martin and Drewry (1978).

rotifers, to provide a transition period. After Day 7, only nauplii are fed, and the age range for the nauplii can be increased from 12-h old to 24-h old.

13.6.17.8 Silverside larvae are very sensitive to handling and shipping during the first week after hatching. For this reason, if organisms must be shipped to the test laboratory, it may be impractical to use larvae less than 11 days old because the sensitivity of younger organisms may result in excessive mortality during shipment. If organisms are to be shipped to a test site, they should be shipped only as (1) early embryos, so that they hatch after arrival, or (2) after they are known to be feeding well on *Artemia* nauplii (8-10 days of age). Larvae shipped at 8-10 days of age would be 9 to 11 days old when the test is started. Larvae that are hatched and reared in the test laboratory can be used at 7 days of age.

13.6.17.9 If four replicates of 15 larvae are used at each effluent concentration and in the control, 360 larvae will be needed for each test.

13.7 EFFLUENT AND RECEIVING WATER COLLECTION, PRESERVATION, AND STORAGE

13.7.1 See Section 8, Effluent and Receiving Water Sampling, Sample Handling, and Sample Preparation for Toxicity Tests.

13.8 CALIBRATION AND STANDARDIZATION

13.8.1 See Section 4, Quality Assurance.

13.9 QUALITY CONTROL

13.9.1 See Section 4, Quality Assurance.

13.10 TEST PROCEDURES

13.10.1 TEST SOLUTIONS

13.10.1.1 Receiving Waters

13.10.1.1.1 The sampling point is determined by the objectives of the test. At estuarine and marine sites, samples are usually collected at mid-depth. Receiving water toxicity is determined with samples used directly as collected or with samples passed through a 60 μm NITEX® filter and compared without dilution, against a control. Using four replicate chambers per test, each containing 500-750 mL, and 400 mL for chemical analysis, would require approximately 2.4-3.4 L or more of sample per day.

13.10.1.2 Effluents

13.10.1.2.1 The selection of the effluent test concentrations should be based on the objectives of the study. A dilution factor of 0.5 is commonly used. A dilution factor of 0.5 provides precision of $\pm 100\%$, and allows for testing of concentrations between 6.25% and 100% effluent using only five effluent concentrations (6.25%, 12.5%, 25%, 50%, and 100%). Test precision shows

little improvement as dilution factors are increased beyond 0.5 and declines rapidly if smaller dilution factors are used. Therefore, USEPA recommends the use of the ≥ 0.5 dilution factor. If 100% salinity HSB is used as a diluent, the maximum concentration of effluent that can be tested will be 80% at 20‰ salinity, and 70% at 30‰ salinity.

13.10.1.2.2 If the effluent is known or suspected to be highly toxic, a lower range of effluent concentrations should be used (such as 25%, 12.5%, 6.25%, 3.12%, and 1.56%). If a high rate of mortality is observed during the first 1 to 2 h of the test, additional dilutions at the lower range of effluent concentrations should be added.

13.10.1.2.3 The volume of effluent required to initiate the test and for daily renewal of four replicates per treatment for five concentrations of effluent and a control, each containing 750 mL of test solution, is approximately 5 L. Prepare enough test solution at each effluent concentration to provide 400 mL additional volume for chemical analyses.

13.10.1.2.4 Tests should begin as soon as possible after sample collection, preferably within 24 h. The maximum holding time following retrieval of the sample from the sampling device should not exceed 36 h for off-site toxicity studies unless permission is granted by the permitting authority. In no case should the test be started more than 72 h after sample collection (see Section 8, Effluent and Receiving Water Sampling, Sample Handling, and Sample Preparation for Toxicity Tests, subsection 8.5.4).

13.10.1.2.5 Just prior to test initiation (approximately 1 h), the temperature of a sufficient quantity of the sample to make the test solution should be adjusted to the test temperature ($25 \pm 1^\circ\text{C}$) and maintained at that temperature during the addition of dilution waters.

13.10.1.2.6 Effluent dilutions should be prepared for all replicates in each treatment in one beaker to minimize variability among the replicates. The test chambers are labelled with the test concentration and replicate number. Dispense into the appropriate effluent dilution chamber.

13.10.1.3 Dilution Water

13.10.1.3.1 Dilution water may be uncontaminated natural seawater (receiving water), HSB prepared from natural seawater, or artificial seawater prepared from FORTY FATHOMS® or GP2 sea salts (see Table 2 and Section 7, Dilution Water). Other artificial sea salts may be used for culturing sheepshead minnows and for the larval survival and growth test if the control criteria for acceptability of test data are satisfied.

13.10.2 START OF THE TEST

13.10.2.1 Inland silverside larvae 7 to 11 days old can be used to start the survival and growth test. At this age, the inland silverside feed on newly-hatched *Artemia* nauplii. At 25°C , tests with inland silverside larvae can be performed at salinities ranging from 5‰ to 32‰. If the test salinity ranges from 16‰ to 32‰, the salinity for spawning, incubation, and culture

of the embryos and larvae should be maintained within this salinity range. If the test salinity is in the range of 5‰ to 15‰, the embryos may be spawned at 30‰, but egg incubation and larval rearing should be at the test salinity. If the specific salinity required for the test differs from the rearing salinity, adjustments of 5‰ daily should be made over the three days prior to start of test.

13.10.2.2 One Day Prior to Beginning of Test

13.10.2.2.1 Set up the *Artemia* culture so that newly hatched nauplii will be available on the day the test begins. (see Section 7).

13.10.2.2.2 Increase the temperature of water bath, room, or incubator to the required test temperature ($25 \pm 1^\circ\text{C}$).

13.10.2.2.3 Label the test chambers with a marking pen. Use of color coded tape to identify each concentration and replicate is helpful. A minimum of five effluent concentrations and a control should be selected for each test. Glass test chambers, such as crystallization dishes, beakers, or chambers with a sump area (Figure 1), with a capacity for 500-750 mL of test solution, should be used.

13.10.2.2.4 Randomize the position of test chambers in the temperature-controlled water bath, room, or incubator at the beginning of the test, using a position chart. Assign numbers for the position of each test chamber using a table of random numbers or similar process (see Appendix A for an example of randomization). Maintain the chambers in this configuration throughout the test, using a position chart.

13.10.2.2.5 Because inland silverside larvae are very sensitive to handling, it is advisable to distribute them to their respective test chambers which contain control water on the day before the test is to begin. Each test chamber should contain 15 larvae (minimum 10) and it is recommended that there be four replicates (minimum of three) for each concentration and control.

13.10.2.2.6 Seven to 11 day old larvae are active and difficult to capture and are subject to handling mortality. Carefully remove larvae (2-3 at a time) by concentrating them in a corner of the aquarium or culture vessel, and capture them with a wide-bore pipette, small petri dish, crystallization dish, 3-4 cm in diameter, or small pipette. They are active and will readily escape from a pipette. Randomly transfer the larvae (2-3 at a time) into each test chamber until the desired number (15) is attained. See Appendix A for an example of randomization. After the larvae are dispensed, use a light table to verify the number in each chamber.

13.10.2.3 Before beginning the test remove and replace any dead larvae from each test chamber. The test is started by removing approximately 90% of the clean seawater from each test chamber and replacing with the appropriate test solution.

13.10.3 LIGHT, PHOTOPERIOD, SALINITY, AND TEMPERATURE

13.10.3.1 The light quality and intensity should be at ambient laboratory levels, which is approximately 10-20 $\mu\text{E}/\text{m}^2/\text{s}$, or 50 to 100 foot candles (ft-c), with a photoperiod of 16 h of light and 8 h of darkness. The water temperature in the test chambers should be maintained at $25 \pm 1^\circ\text{C}$. The test salinity should be in the range of 5‰ to 32‰, and the salinity should not vary by more than $\pm 2\%$ among the chambers on a given day. If effluent and receiving water tests are conducted concurrently, the salinities of these tests should be similar.

13.10.4 DISSOLVED OXYGEN (DO) CONCENTRATION

13.10.4.1 Aeration may affect the toxicity of effluents and should be used only as a last resort to maintain satisfactory DO. The DO should be measured on new solutions at the start of the test (Day 0) and before daily renewal of test solutions on subsequent days. The DO should not fall below 4.0 mg/L (see Section 8, Effluent and Receiving Water Sampling, Sample Handling and Sample Preparation for Toxicity Tests). If it is necessary to aerate, all concentrations and the control should be aerated. The aeration rate should not exceed 100 bubbles/min, using a pipet with a 1-2 mm orifice such as a 1-mL KIMAX® serological pipet No. 37033, or equivalent. Care should be taken to ensure that turbulence resulting from aeration does not cause undue stress to the fish.

13.10.5 FEEDING

13.10.5.1 *Artemia* nauplii are prepared as described above.

13.10.5.2 The test larvae are fed newly-hatched (less than 24-h-old) *Artemia* nauplii once a day from Day 0 through Day 6; larvae are not fed on Day 7. Equal amounts of *Artemia* nauplii must be fed to each replicate test chamber to minimize the variability of larval weight. Sufficient numbers of nauplii should be fed to ensure that some remain alive overnight in the test chambers. An adequate, but not excessive amount of *Artemia* nauplii, should be provided to each replicate on a daily basis. Feeding excessive amounts of *Artemia* nauplii will result in a depletion in DO to below an acceptable level. Siphon as much of the uneaten *Artemia* nauplii as possible from each chamber daily to ensure that the larvae principally eat newly hatched nauplii.

13.10.5.3 On days 0-2, transfer 4 g wet weight or pipette 4 mL of concentrated, rinsed *Artemia* nauplii to seawater in a 100 mL beaker, and bring to a volume of 80 mL. Aerate or swirl the suspension to equally distribute the nauplii while withdrawing individual 2 mL portions of the *Artemia* nauplii suspension by pipette or adjustable syringe to transfer to each replicate test chamber. Because the nauplii will settle and concentrate at the tip of the pipette during the transfer, limit the volume of concentrate withdrawn each time to a 2-mL portion for one test chamber helps ensure an equal distribution to the replicate chambers. Equal distribution of food to the replicates is critical for successful tests.

13.10.5.4 On days 3-6, transfer 6 g wet weight or 6 mL of the *Artemia* nauplii concentrate to seawater in a 100 mL beaker. Bring to a volume of 80 mL and dispense as described above.

13.10.5.5 If the larvae survival rate in any replicate on any day falls below 50%, reduce the volume of *Artemia* nauplii suspension added to that test chamber by one-half (i.e., reduce from 2 mL to 1 mL) and continue feeding one-half the volume through day 6. Record the time of feeding on the data sheets.

13.10.6 DAILY CLEANING OF TEST CHAMBERS

13.10.6.1 Before the daily renewal of test solutions, uneaten and dead *Artemia*, and other debris are removed from the bottom of the test chambers with a siphon hose. Alternately, a large pipet (50 mL), fitted with a safety pipet filler or rubber bulb, can be used. If the test chambers illustrated in Figure 1 are used, remove only as much of the test solution from the chamber as is necessary to clean, and siphon the remainder of the test solution from the sump area. Because of their small size during the first few days of the test, larvae are easily drawn into a siphon tube when cleaning the test chambers. By placing the test chambers on a light box, inadvertent removal of larvae can be greatly reduced because they can be more easily seen. If the water siphoned from the test chambers is collected in a white plastic tray, the live larvae caught up in the siphon can be retrieved, and returned by pipette to the appropriate test chamber and noted on data sheet. Any incidence of removal of live larvae from the test chambers by the siphon during cleaning, and subsequent return to the chambers should be noted in the test records.

13.10.7 OBSERVATIONS DURING THE TEST

13.10.7.1 Routine Chemical and Physical Determinations

13.10.7.1.1 DO is measured at the beginning and end of each 24-h exposure period in one test chamber at all test concentrations and in the control.

13.10.7.1.2 Temperature, pH, and salinity are measured at the end of each 24-h exposure period in one test chamber at all test concentrations and in the control. Temperature should also be monitored continuously or observed and recorded daily for at least two locations in the environmental control system or the samples. Temperature should be measured in a sufficient number of test chambers at least the end of the test to determine the temperature variation in the environmental chamber.

13.10.7.1.3 The pH is measured in the effluent sample each day before new test solutions are made.

13.10.7.1.4 Record all measurements on the data sheet (Figure 3).

13.10.7.2 Routine Biological Observation

Test Dates: _____ Species: _____
 Type Effluent: _____ Field _____ Lab _____ Test _____
 Effluent Tested: _____

CONCENTRATION:																																
REPLICATE:							REPLICATE:							REPLICATE:							REPLICATE:											
DAYS	0	1	2	3	4	5	6	7	0	1	2	3	4	5	6	7	0	1	2	3	4	5	6	7	0	1	2	3	4	5	6	7
# LIVE LARVAE																																
TEMP (°C)																																
SALINITY (‰)																																
DO (mg/L)																																
# LARVAE / DRY WT																																

13.10.7.2.1 The number of live larvae in each test chamber are recorded daily (Figure 3), and the dead larvae are discarded.

13.10.7.2.2 Protect the larvae from unnecessary disturbances during the test by carrying out the daily test observations, solution renewals, and removal of dead larvae. Make sure the larvae remain immersed at all times during the performance of the above operations.

13.10.8 TEST SOLUTION RENEWAL

13.10.8.1 The test solutions are renewed daily using freshly prepared solutions, immediately after cleaning the test chambers. The water level in each chamber is lowered to a depth of 7-to-10 mm, leaving 10 to 15% of the test solution. New test solution is added slowly by refilling each chamber with the appropriate amount of test solution without excessively disturbing the larvae. If the modified chamber is used (Figure 1), renewals should be poured into the sump area using a narrow bore (approximately 9 mm ID) funnel.

13.10.8.2 The effluent or receiving water used in the test is stored in an incubator or refrigerator at 4°C. Plastic containers such as 8-20 L cubitainers have proven suitable for effluent collection and storage. For on-site toxicity studies no more than 24 h should elapse between collection of the effluent and use in a toxicity test (see Section 8, Effluent and Receiving Water Sampling, Sample Handling, and Sample Preparation for Toxicity Tests).

13.10.8.3 Approximately 1 h before test initiation, a sufficient quantity of effluent or receiving water sample is warmed to $25 \pm 1^\circ\text{C}$ to prepare the test solutions. A sufficient quantity of effluent should be warmed to make the daily test solutions.

13.10.8.3.1 An illustration of the quantities of effluent and seawater needed to prepare test solution at the appropriate salinity is provided in Table 2.

13.10.9 TERMINATION OF THE TEST

13.10.9.1 The test is terminated after 7 days of exposure. At test termination dead larvae are removed and discarded. The surviving larvae in each test chamber (replicate) are counted, and immediately prepared as a group for dry weight determination, or are preserved in 4% formalin or 70% ethanol. Preserved organisms are dried and weighed within 7 d. For safety, formalin should be used under a hood.

13.10.9.2 For immediate drying and weighing, siphon or pour live larvae onto a 500 μm mesh screen in a large beaker to retain the larvae and allow *Artemia* to be rinsed away. Rinse the larvae with deionized water to remove salts that might contribute to the dry weight. Sacrifice the larvae in an ice bath of deionized water.

13.10.9.3 Small aluminum weighing pans can be used to dry and weigh larvae. An appropriate number of aluminum weigh pans (one per replicate) are marked for identification and weighed to 0.01 mg, and the weights are recorded (Figure 4) on the data sheets.

13.10.9.4 Immediately prior to drying, the preserved larvae are in distilled water. The rinsed larvae from each test chamber are transferred, using forceps, to a tared weighing pans and dried at 60°C for 24 h, or at 105°C for a minimum of 6 h. Immediately upon removal from the drying oven, the weighing pans are placed in a desiccator to cool and to prevent the adsorption of moisture from the air until weighed. Weigh all weighing pans containing the dried larvae to 0.01 mg, subtract the tare weight to determine dry weight of larvae in each replicate. Record (Figure 4) the weights. Divide the dry weight by the number of original larvae per replicate to determine the average dry weight, and record (Figures 4 and 5) on the data sheets. For the controls, also calculate the mean weight per surviving fish in the test chamber to evaluate if weights met test acceptability criteria (see Subsection 13.1). Complete the summary data sheet (Figure 5) after calculating the average measurements and statistically analyzing the dry weights and percent survival for the entire test. Average weights should be expressed to the nearest 0.001 mg.

13.11 SUMMARY OF TEST CONDITIONS AND TEST ACCEPTABILITY CRITERIA

13.11.1 A summary of test conditions and test acceptability criteria is listed in Table 3.

13.12 ACCEPTABILITY OF TEST RESULTS

13.12.1 Test results are acceptable if (1) the average survival of control larvae is equal to or greater than 80%, and (2) where the test starts with 7-day old larvae, the average dry weight per surviving control larvae, when dried immediately after test termination, is equal to or greater than 0.50 mg, or the average dry weight of the control larvae preserved not more than 7 days in 4% formalin or 70% ethanol equals or exceeds 0.43 mg.

13.13 DATA ANALYSIS

13.13.1 GENERAL

13.13.1.1 Tabulate and summarize the data.

13.13.1.2 The endpoints of toxicity tests using the inland silverside are based on the adverse effects on survival and growth. The LC50, the IC25, and the IC50 are calculated using point estimation techniques (see Section 9, Chronic Toxicity Test Endpoints and Data Analysis). LOEC and NOEC values, for survival and growth, are obtained using a hypothesis testing approach such as Dunnett's Procedure (Dunnett, 1955) or Steel's Many-one Rank Test (Steel, 1959; Miller, 1981) (see Section 9). Separate analyses are performed for the estimation of the LOEC and NOEC endpoints and for the estimation of the LC50, IC25, and IC50. Concentrations at which there is no survival in any of the test chambers are excluded from the statistical analysis of the NOEC and LOEC for survival and growth but included in the estimation of the LC50, IC25, and IC50. See the Appendices for examples of the manual computations and examples of data input and program output.

Test Dates: _____ Species: _____

Effluent Tested: _____

TREATMENT						
NO. LIVE LARVAE						
SURVIVAL (%)						
MEAN DRY WT/LARVAE (MG) ± SD						
SIGNIF. DIFF. FROM CONTROL (o)						
MEAN TEMPERATURE (°C) ± SD						
MEAN SALINITY ‰ ± SD						
AVE. DISSOLVED OXYGEN (MG/L) ± SD						

COMMENTS:

Figure 5. Data form for the inland silverside, *Menidia beryllina*, larval survival and growth test. Summary of test results (from USEPA, 1987c).

TABLE 3. SUMMARY OF TEST CONDITIONS AND TEST ACCEPTABILITY CRITERIA FOR THE INLAND SILVERSIDE, *MENIDIA BERYLLINA*, LARVAL SURVIVAL AND GROWTH TEST WITH EFFLUENTS AND RECEIVING WATERS

1. Test type:	Static renewal
2. Salinity:	5‰ to 32‰ (\pm 2‰ of the selected test salinity)
3. Temperature:	25 \pm 1°C
4. Light quality:	Ambient laboratory illumination
5. Light intensity:	10-20 μ E/m ² /s (50-100 ft-c) (Ambient laboratory levels)
6. Photoperiod:	16 h light, 8 h darkness
7. Test chamber size:	600 mL - 1 L containers
8. Test solution volume:	500-750 mL/replicate (loading and DO restrictions must be met)
9. Renewal of test solutions:	Daily
10. Age of test organisms:	7-11 days post hatch; 24-h range in age
11. No. larvae per test chamber:	15 (minimum of 10)
12. No. replicate chambers per concentration:	4 (minimum of 3)
13. No. larvae per concentration:	60 (minimum of 30)
14. Source of food:	Newly hatched <i>Artemia</i> nauplii (survival of 7-9 days old <i>Menidia beryllina</i> larvae improved by feeding 24 h old <i>Artemia</i>)
15. Feeding regime:	Feed 0.10 g wet weight <i>Artemia</i> nauplii per replicate on days 0-2; Feed 0.15 g wet weight <i>Artemia</i> nauplii per replicate on days 3-6
16. Cleaning:	Siphon daily, immediately before test solution renewal and feeding

TABLE 3. SUMMARY OF TEST CONDITIONS AND TEST ACCEPTABILITY CRITERIA FOR THE INLAND SILVERSIDE, *MENIDIA BERYLLINA*, LARVAL SURVIVAL AND GROWTH TEST WITH EFFLUENTS AND RECEIVING WATERS (CONTINUED)

17. Aeration:	None, unless DO concentration falls below 4.0 mg/L, then aerate all chambers. Rate should be less than 100 bubbles/min.
18. Dilution water:	Uncontaminated source of natural sea water, artificial seawater; deionized water mixed with hypersaline brine or artificial sea salts (HW Marinemix®, FORTY FATHOMS®, GP2 or equivalent)
19. Test concentrations:	Effluent: Minimum of 5 and a control Receiving Waters: 100% receiving water or minimum of 5 and a control
20. Dilution factor:	Effluents: ≥ 0.5 Receiving waters: None, or ≥ 0.5
21. Test duration:	7 days
22. Endpoints:	Survival and growth (weight)
23. Test acceptability criteria:	80% or greater survival in controls, 0.50 mg average dry weight of control larvae where test starts with 7-days old larvae and dried immediately after test termination, <u>or</u> 0.43 mg or greater average dry weight per surviving control larvae, preserved not more than 7 days in 4% formalin or 70% ethanol
24. Sampling requirement:	For on-site tests, samples collected daily, and used within 24 h of the time they are removed from the sampling device. For off-site tests, a minimum of three samples are collected on days one, three, and five with a maximum holding time of 36 h before first use (see Section 8, Effluent and Receiving Water Sampling, Sample Handling, and Sample Preparation for Toxicity Tests, Subsection 8.5.4)
25. Sample volume required:	6 L per day

13.13.1.3 The statistical tests described here must be used with a knowledge of the assumptions upon which the tests are contingent. The assistance of a statistician is recommended for analysts who are not proficient in statistics.

13.13.2 EXAMPLE OF ANALYSIS OF INLAND SILVERSIDE, *MENIDIA BERYLLINA*, SURVIVAL DATA

13.13.2.1 Formal statistical analysis of the survival data is outlined in Figures 6 and 7. The response used in the analysis is the proportion of animals surviving in each test or control chamber. Separate analyses are performed for the estimation of the NOEC and LOEC endpoints and for the estimation of the LC50 endpoint. Concentrations at which there is no survival in any of the test chambers are excluded from statistical analysis of the NOEC and LOEC, but included in the estimation of the IC, EC, and LC endpoint.

13.13.2.2 For the case of equal numbers of replicates across all concentrations and the control, the evaluation of the NOEC and LOEC endpoints is made via a parametric test, Dunnett's Procedure, or a nonparametric test, Steel's Many-one Rank Test, on the arc sine square root transformed data. Underlying assumptions of Dunnett's Procedure, normality and homogeneity of variance, are formally tested. The test for normality is the Shapiro-Wilk's Test, and Bartlett's Test is used to test for the homogeneity of variance. If either of these tests fails, the nonparametric test, Steel's Many-one Rank Test, is used to determine the NOEC and LOEC endpoints. If the assumptions of Dunnett's Procedure are met, the endpoints are estimated by the parametric procedure.

13.13.2.3 If unequal numbers of replicates occur among the concentration levels tested, there are parametric and nonparametric alternative analyses. The parametric analysis is a t test with the Bonferroni adjustment (see Appendix D). The Wilcoxon Rank Sum Test with the Bonferroni adjustment is the nonparametric alternative.

13.13.2.4 Probit Analysis (Finney, 1971; see Appendix H) is used to estimate the concentration that causes a specified percent decrease in survival from the control. In this analysis, the total mortality data from all test replicates at a given concentration are combined. If the data do not fit the Probit model, the Spearman-Kärber method, the Trimmed Spearman-Kärber method, or the Graphical method may be used (see Appendices H-K).

13.13.2.5 Example of Analysis of Survival Data

13.13.2.5.1 This example uses the survival data from the inland silverside larval survival and growth test. The proportion surviving in each replicate in this example must first be transformed by the arc sine transformation procedure described in Appendix B. The raw and transformed data, means and variances of the transformed observations at each effluent concentration and control are listed in Table 4. A plot of the data is provided in Figure 8. Since there is 100% mortality in all three replicates for the 50% and 100% concentrations, they are not included in this statistical analysis and are considered a qualitative mortality effect.

**STATISTICAL ANALYSIS OF INLAND SILVERSIDE LARVAL
SURVIVAL AND GROWTH TEST**

SURVIVAL HYPOTHESIS TESTING

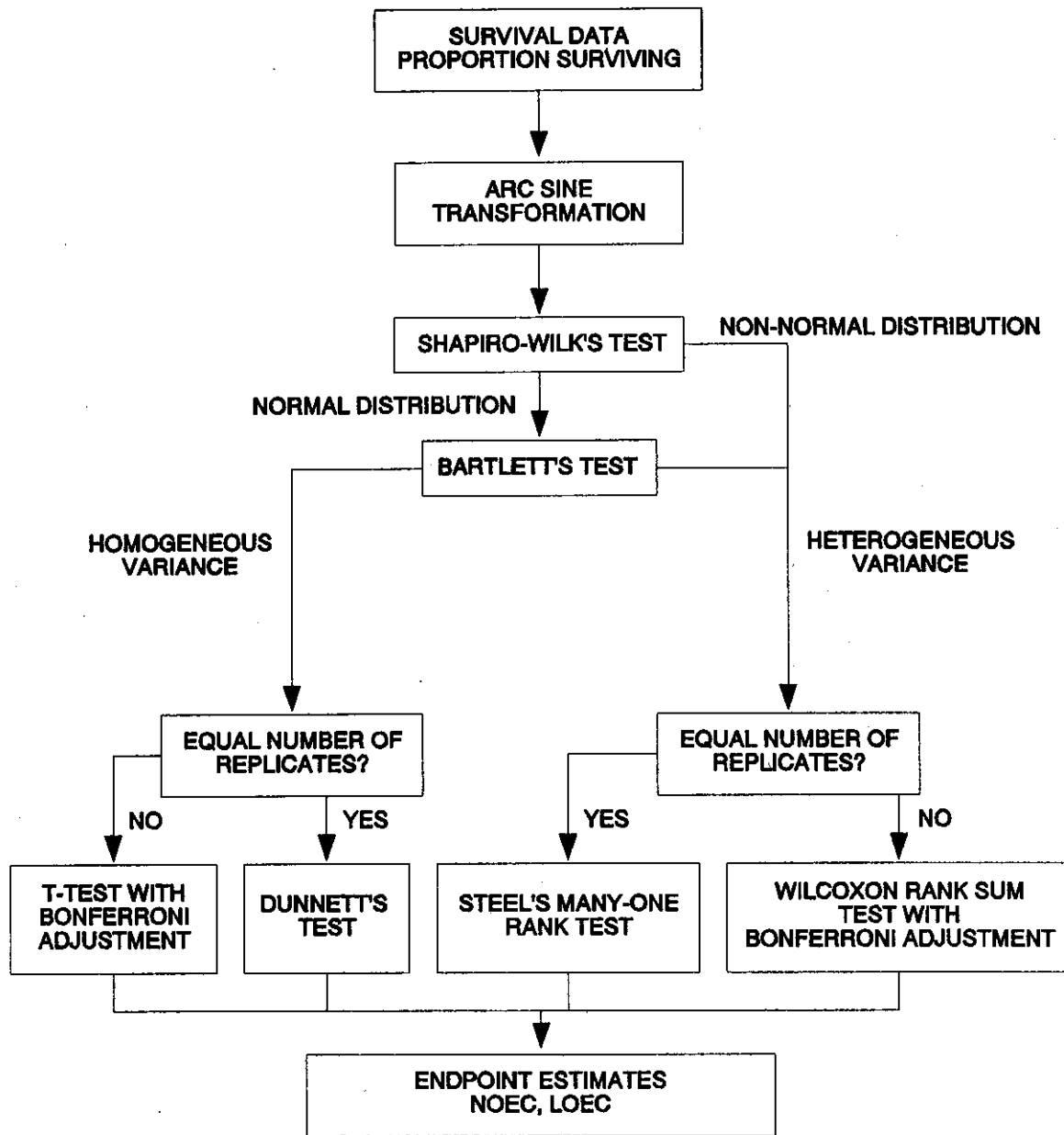

Figure 6. Flowchart for statistical analysis of the inland silverside, *Menidia beryllina*, survival data by hypothesis testing.

STATISTICAL ANALYSIS OF INLAND SILVERSIDE LARVAL SURVIVAL AND GROWTH TEST

SURVIVAL POINT ESTIMATION

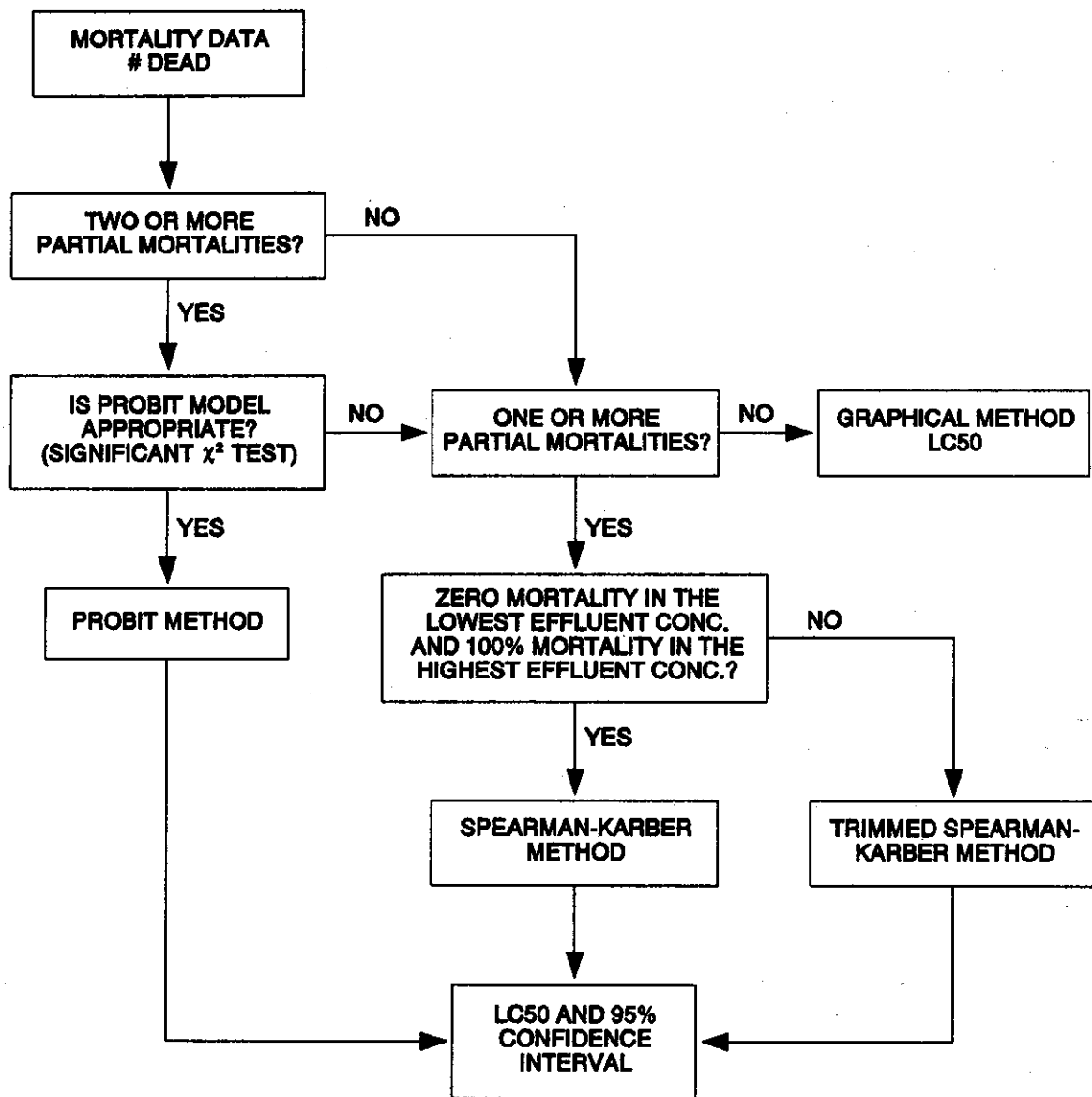

Figure 7. Flowchart for statistical analysis of the inland silverside, *Menidia beryllina*, survival data by point estimation.

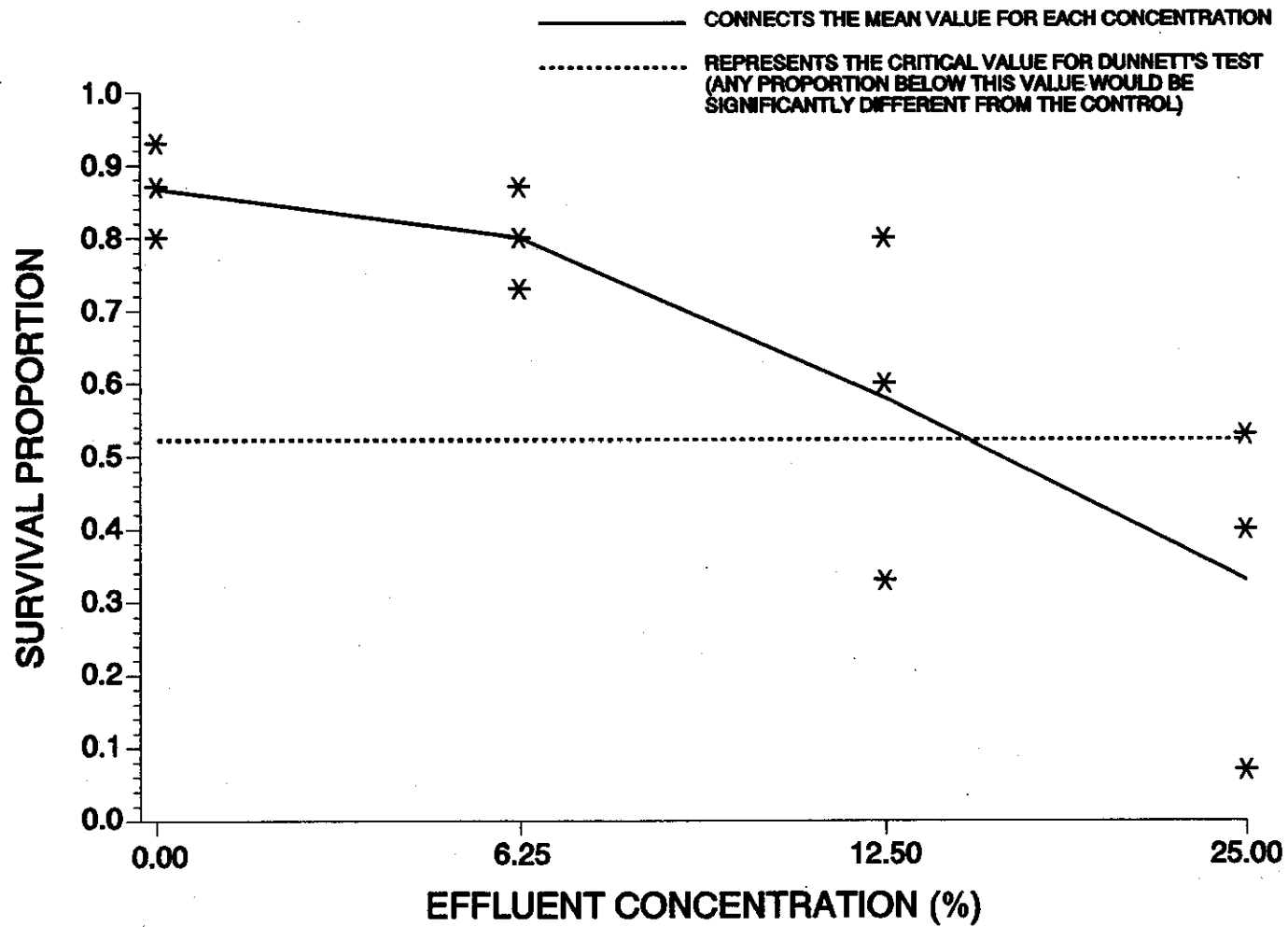

Figure 8. Plot of mean survival proportion of the inland silverside, *Menidia beryllina*, larvae.

TABLE 4. INLAND SILVERSIDE, *MENIDIA BERYLLINA*, LARVAL SURVIVAL DATA

Replicate	Control	Effluent Concentration(%)					
		6.25	12.5	25.0	50.0	100.0	
RAW	A	0.80	0.73	0.80	0.40	0.0	0.0
	B	0.87	0.80	0.33	0.53	0.0	0.0
	C	0.93	0.87	0.60	0.07	0.0	0.0
ARC SINE	A	1.107	1.024	1.107	0.685	-	-
TRANS-	B	1.202	1.107	0.612	0.815	-	-
FORMED	C	1.303	1.202	0.886	0.268	-	-
Mean(\bar{Y}_i)		1.204	1.111	0.868	0.589		
S_i^2		0.010	0.008	0.061	0.082		
i		1	2	3	4		

13.13.2.6 Test for Normality

13.13.2.6.1 The first step of the test for normality is to center the observations by subtracting the mean of all observations within a concentration from each observation in that concentration. The centered observations are summarized in Table 5.

TABLE 5. CENTERED OBSERVATIONS FOR SHAPIRO-WILK'S EXAMPLE

Replicate	Control	Effluent Concentration (%)		
		6.25	12.5	25.0
A	-0.097	-0.087	0.239	0.096
B	-0.002	-0.004	-0.256	0.226
C	0.099	0.091	0.018	-0.321

13.13.2.6.2 Calculate the denominator, D, of the statistic:

$$D = \sum_{i=1}^n (X_i - \bar{X})^2$$

Where: X_i = the i th centered observation

\bar{X} = the overall mean of the centered observations

n = the total number of centered observations

13.13.2.6.3 For this set of data, $n = 12$

$$\bar{X} = \frac{1}{12} (0.002) = 0.0$$

$$D = 0.3214$$

13.13.2.6.4 Order the centered observations from smallest to largest:

$$X^{(1)} \leq X^{(2)} \leq \dots \leq X^{(n)}$$

where $X^{(i)}$ denotes the i th ordered observation. The ordered observations for this example are listed in Table 6.

TABLE 6. ORDERED CENTERED OBSERVATIONS FOR SHAPIRO-WILK'S EXAMPLE

i	$X^{(i)}$	i	$X^{(i)}$
1	-0.321	7	0.018
2	-0.256	8	0.091
3	-0.097	9	0.096
4	-0.087	10	0.099
5	-0.004	11	0.226
6	-0.002	12	0.239

13.13.2.6.5 From Table 4, Appendix B, for the number of observations, n , obtain the coefficients a_1, a_2, \dots, a_k where k is $n/2$ if n is even and $(n-1)/2$ if n is odd. For the data in this example, $n = 12$ and $k = 6$. The a_i values are listed in Table 7.

13.13.2.6.6 Compute the test statistic, W, as follows:

$$W = \frac{1}{D} \left[\sum_{i=1}^k a_i (X^{(n-i+1)} - X^{(i)}) \right]^2$$

The differences $X^{(n-i+1)} - X^{(i)}$ are listed in Table 7. For the data in this example,

$$W = \frac{1}{0.3214} (0.5513)^2 = 0.945$$

TABLE 7. COEFFICIENTS AND DIFFERENCES FOR SHAPIRO-WILK'S EXAMPLE

i	a_i	$X^{(n-i+1)} - X^{(i)}$	
1	0.5475	0.560	$X^{(12)} - X^{(1)}$
2	0.3325	0.482	$X^{(11)} - X^{(2)}$
3	0.2347	0.196	$X^{(10)} - X^{(3)}$
4	0.1586	0.183	$X^{(9)} - X^{(4)}$
5	0.0922	0.095	$X^{(8)} - X^{(5)}$
6	0.0303	0.020	$X^{(7)} - X^{(6)}$

13.13.2.6.7 The decision rule for this test is to compare W as calculated in Subsection 13.2.6.6 to a critical value found in Table 6, Appendix B. If the computed W is less than the critical value, conclude that the data are not normally distributed. For the data in this example, the critical value at a significance level of 0.01 and $n = 12$ observations is 0.805. Since $W = 0.945$ is greater than the critical value, conclude that the data are normally distributed.

13.13.2.7 Test for Homogeneity of Variance

13.13.2.7.1 The test used to examine whether the variation in survival is the same across all effluent concentrations including the control, is Bartlett's Test (Snedecor and Cochran, 1980). The test statistic is as follows:

$$B = \frac{[(\sum_{i=1}^p V_i) 1n \bar{S}^2 - \sum_{i=1}^p V_i 1n S_i^2]}{C}$$

Where: V_i = degrees of freedom for each effluent concentration and control, $V_i = (n_i - 1)$

p = number of levels of effluent concentration including the control

$1n = \log_e$

$i = 1, 2, \dots, p$ where p is the number of concentrations including the control

$n_i =$ the number of replicates for concentration i .

$$\bar{S}^2 = \frac{(\sum_{i=1}^p V_i S_i^2)}{\sum_{i=1}^p V_i}$$

$$C = 1 + [3(p-1)]^{-1} [\sum_{i=1}^p 1/V_i - (\sum_{i=1}^p V_i)^{-1}]$$

13.13.2.7.2 For the data in this example (See Table 4), all effluent concentrations including the control have the same number of replicates ($n_i = 3$ for all i). Thus, $V_i = 2$ for all i .

13.13.2.7.3 Bartlett's statistic is therefore:

$$\begin{aligned} B &= [(8)1n(0.0402) - 2 \sum_{i=1}^p 1n(S_i^2)] / 1.2083 \\ &= [8(-3.21391) - 2(-14.731)] / 1.2083 \\ &= 3.7508 / 1.2083 \\ &= 3.104 \end{aligned}$$

13.13.2.7.4 B is approximately distributed as chi-square with $p - 1$ degrees of freedom, when the variances are in fact the same. Therefore, the appropriate critical value for this test, at a significance level of 0.01 with three degrees of freedom, is 11.345. Since $B = 3.104$ is less than the critical value of 11.345, conclude that the variances are not different.

13.13.2.8 Dunnett's Procedure

13.13.2.8.1 To obtain an estimate of the pooled variance for the Dunnett's Procedure, construct an ANOVA table as described in Table 8.

TABLE 8. ANOVA TABLE

Source	df	Sum of Squares (SS)	Mean Square (MS) (SS/df)
Between	p - 1	SSB	$S_B^2 = SSB/(p-1)$
Within	N - p	SSW	$S_W^2 = SSW/(N-p)$
Total	N - 1	SST	

Where: p = number of SDS concentration levels including the control
 N = total number of observations $n_1 + n_2 \dots + n_p$
 n_i = number of observations in concentration i

$$SSB = \sum_{i=1}^p T_i^2/n_i - G^2/N \quad \text{Between Sum of Squares}$$

$$SST = \sum_{i=1}^p \sum_{j=1}^{n_i} Y_{ij}^2 - G^2/N \quad \text{Total Sum of Squares}$$

$$SSW = SST - SSB \quad \text{Within Sum of Squares}$$

G = the grand total of all sample observations, $G = \sum_{i=1}^p T_i$

T_i = the total of the replicate measurements for concentration i

Y_{ij} = the jth observation for concentration i (represents the proportion surviving for toxicant concentration i in test chamber j)

13.13.2.8.2 For the data in this example:

$$n_1 = n_2 = n_3 = n_4 = 3$$

$$N = 12$$

$$T_1 = Y_{11} + Y_{12} + Y_{13} = 3.612$$

$$T_2 = Y_{21} + Y_{22} + Y_{23} = 3.333$$

$$T_3 = Y_{31} + Y_{32} + Y_{33} = 2.605$$

$$T_4 = Y_{41} + Y_{42} + Y_{43} = 1.768$$

$$G = T_1 + T_2 + T_3 + T_4 = 11.318$$

$$\begin{aligned} SSB &= \sum_{i=1}^p T_i^2/n_i - G^2/N \\ &= \frac{1}{3} (34.067) - \frac{(11.318)^2}{12} = 0.681 \end{aligned}$$

$$\begin{aligned} SST &= \sum_{i=1}^p \sum_{j=1}^{n_i} Y_{ij}^2 - G^2/N \\ &= 11.677 - \frac{(11.318)^2}{12} = 1.002 \end{aligned}$$

$$SSW = SST - SSB = 1.002 - 0.681 = 0.321$$

$$S_B^2 = SSB/(p-1) = 0.681/(4-1) = 0.227$$

$$S_W^2 = SSW/(N-p) = 0.321/(12-4) = 0.040$$

13.13.2.8.3 Summarize these calculations in the ANOVA table (Table 9).

TABLE 9. ANOVA TABLE FOR DUNNETT'S PROCEDURE EXAMPLE

Source	df	Sum of Squares (SS)	Mean Square (MS) (SS/df)
Between	3	0.681	0.227
Within	8	0.321	0.040
Total	11	1.002	

13.13.2.8.4 To perform the individual comparisons, calculate the t statistic for each concentration, and control combination as follows:

$$t_i = \frac{(\bar{Y}_1 - \bar{Y}_i)}{S_w \sqrt{(1/n_1) + (1/n_i)}}$$

Where: \bar{Y}_i = mean proportion surviving for effluent concentration i

\bar{Y}_1 = mean proportion surviving for the control

S_w = square root of the within mean square

n_1 = number of replicates for the control

n_i = number of replicates for concentration i.

13.13.2.8.5 Table 10 includes the calculated t values for each concentration and control combination. In this example, comparing the 1.0% concentration with the control the calculation is as follows:

$$t_2 = \frac{(1.204 - 1.111)}{[0.020 \sqrt{(1/3) + (1/3)}]} = 0.570$$

TABLE 10. CALCULATED T VALUES

Effluent Concentration(%)	i	t_i
6.25	2	0.570
12.5	3	2.058
25.0	4	3.766

13.13.2.8.6 Since the purpose of this test is to detect a significant reduction in survival, a one-sided test is appropriate. The critical value for this one-sided test is found in Table 5, Appendix C. For an overall alpha level of 0.05, eight degrees of freedom for error and three concentrations (excluding the control) the critical value is 2.42. The mean proportion surviving for concentration i is considered significantly less than the mean proportion surviving for the control if t_i is greater than the critical value. Therefore, only the 25.0% concentration has a significantly lower mean proportion surviving than the control. Hence the NOEC is 12.5% and the LOEC is 25.0%.

13.13.2.8.7 To quantify the sensitivity of the test, the minimum significant difference (MSD) that can be detected statistically may be calculated.

$$MSD = d S_w \sqrt{(1/n_1) + (1/n)}$$

Where: d = the critical value for Dunnett's Procedure

S_w = the square root of the within mean square

n = the common number of replicates at each concentration
(this assumes equal replication at each concentration)

n_1 = the number of replicates in the control.

13.13.2.8.8 In this example:

$$\begin{aligned} MSD &= 2.42 (0.20) \sqrt{(1/3) + (1/3)} \\ &= 2.42 (0.20) (0.817) \\ &= 0.395 \end{aligned}$$

13.13.2.8.9 The MSD (0.395) is in transformed units. To determine the MSD in terms of percent survival, carry out the following conversion.

1. Subtract the MSD from the transformed control mean.

$$1.204 - 0.395 = 0.809$$

2. Obtain the untransformed values for the control mean and the difference calculated in step 1.

$$[\text{Sine} (1.204)]^2 = 0.871$$

$$[\text{Sine} (0.809)]^2 = 0.524$$

3. The untransformed MSD (MSD_u) is determined by subtracting the untransformed values from step 2.

$$MSD_u = 0.871 - 0.524 = 0.347$$

13.13.2.8.10 Therefore, for this set of data, the minimum difference in mean proportion surviving between the control and any effluent concentration that can be detected as statistically significant is 0.347.

13.13.2.8.11 This represents a 40% decrease in survival from the control.

13.13.2.9 Calculation of the LC50

13.13.2.9.1 The data used for the Probit Analysis is summarized in Table 11. To perform the Probit Analysis, run the USEPA Probit Analysis Program. An example of the program input and output is supplied in Appendix H.

TABLE 11. DATA FOR PROBIT ANALYSIS

	Effluent Concentration (%)					
	Control	6.25	12.5	25.0	50.0	100.0
Number Dead	6	9	19	30	45	45
Number Exposed	45	45	45	45	45	45

13.13.2.9.2 For this example, the chi-square test for heterogeneity was not significant. Thus Probit Analysis appears to be appropriate for this set of data.

13.13.2.9.3 Figure 9 shows the output data for the Probit Analysis of the data from Table 11 using the USEPA Probit Program.

13.13.3 ANALYSIS OF INLAND SILVERSIDE, *MENEDIA BERYLLINA*, GROWTH DATA

13.13.3.1 Formal statistical analysis of the growth data is outlined in Figure 10. The response used in the statistical analysis is mean weight per original organism for each replicate. The IC25 and IC50 can be calculated for the growth data via a point estimation technique (see Section 9, Chronic Toxicity Test Endpoints and Data Analysis). Hypothesis testing can be used to obtain an NOEC and LOEC for growth. Concentrations above the NOEC for survival are excluded from the hypothesis test for growth effects.

13.13.3.2 The statistical analysis using hypothesis tests consists of a parametric test, Dunnett's Procedure, and a nonparametric test, Steel's Many-one Rank Test. The underlying assumptions of the Dunnett's Procedure, normality and homogeneity of variance, are formally tested. The test for normality is the Shapiro-Wilk's Test and Bartlett's Test is used to test for homogeneity of variance. If either of these test fails, the nonparametric test, Steel's Many-one Rank Test, is used to determine the NOEC and LOEC endpoints. If the assumptions of Dunnett's Procedure are met, the endpoints are determined by the parametric test.

13.13.3.3 Additionally, if unequal numbers of replicates occur among the concentration levels tested there are parametric and nonparametric alternative analyses. The parametric analysis is a t test with the Bonferroni adjustment. The Wilcoxon Rank Sum Test with the Bonferroni adjustment is the nonparametric alternative. For detailed information on the Bonferroni adjustment, see Appendix D.

Probit Analysis of Inland Silverside Larval Survival Data

Conc.	Number Exposed	Number Resp.	Observed Proportion Responding	Proportion Responding Adjusted for Controls
Control	45	6	0.1333	0.0000
6.2500	45	9	0.2000	0.0488
12.5000	45	19	0.4222	0.3130
25.0000	45	30	0.6667	0.6037
50.0000	45	45	1.0000	1.0000
100.0000	45	45	1.0000	1.0000

Chi - Square for Heterogeneity (calculated) = 4.149
 Chi - Square for Heterogeneity (tabular value) = 7.815

Probit Analysis of Inland Silverside Larval Survival Data

Estimated LC/EC Values and Confidence Limits

Point	Exposure Conc.	Lower 95% Confidence Limits	Upper 95% Confidence Limits
LC/EC 1.00	4.980	2.023	7.789
LC/EC 50.00	18.302	13.886	22.175

Figure 9. Output for USEPA Probit Analysis Program, Version 1.5.

STATISTICAL ANALYSIS OF INLAND SILVERSIDE LARVAL SURVIVAL AND GROWTH TEST

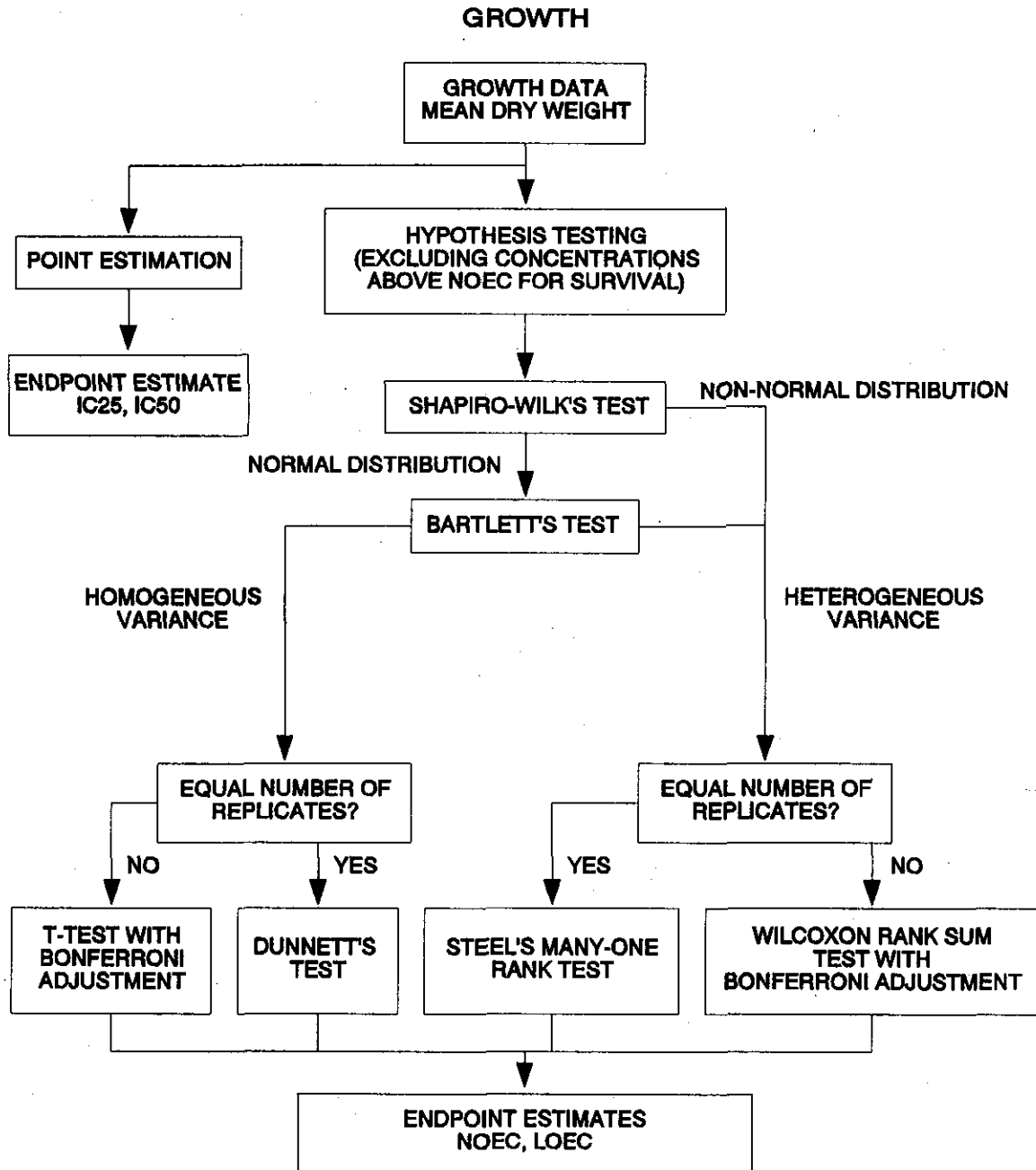

Figure 10. Flowchart for statistical analysis of the inland silverside, *Menidia beryllina*, growth data.

13.13.3.4 The data, mean and variance of the growth observations at each concentration including the control are listed in Table 12. A plot of the data is provided in Figure 11. Since there was no survival in the 50% and 100% concentrations, these are not considered in the growth analysis. Additionally, since there is significant mortality in the 25% effluent concentration, its effect on growth is not considered.

TABLE 12. INLAND SILVERSIDE, *MENIDIA BERYLLINA*, GROWTH DATA

Replicate	Control	Effluent Concentration (%)				
		6.25	12.5	25.0	50.0	100.0
A	0.751	0.737	0.722	0.196	-	-
B	0.849	0.922	0.285	0.312	-	-
C	0.907	0.927	0.718	1.079	-	-
Mean (\bar{Y}_i)	0.836	0.859	0.575	0.196	-	-
S_i^2	0.0062	0.0130	0.063	0.0136	-	-
i	1	2	3	4	5	6

13.13.3.5 Test for Normality

13.13.3.5.1 The first step of the test for normality is to center the observations by subtracting the mean of all the observations within a concentration from each observation in that concentration. The centered observations are summarized in Table 13.

TABLE 13. CENTERED OBSERVATIONS FOR SHAPIRO-WILK'S EXAMPLE

Replicate	Control	Effluent Concentration (%)	
		6.25	12.5
A	-0.085	0.147	0.00
B	0.013	-0.290	0.166
C	0.071	0.143	-0.117

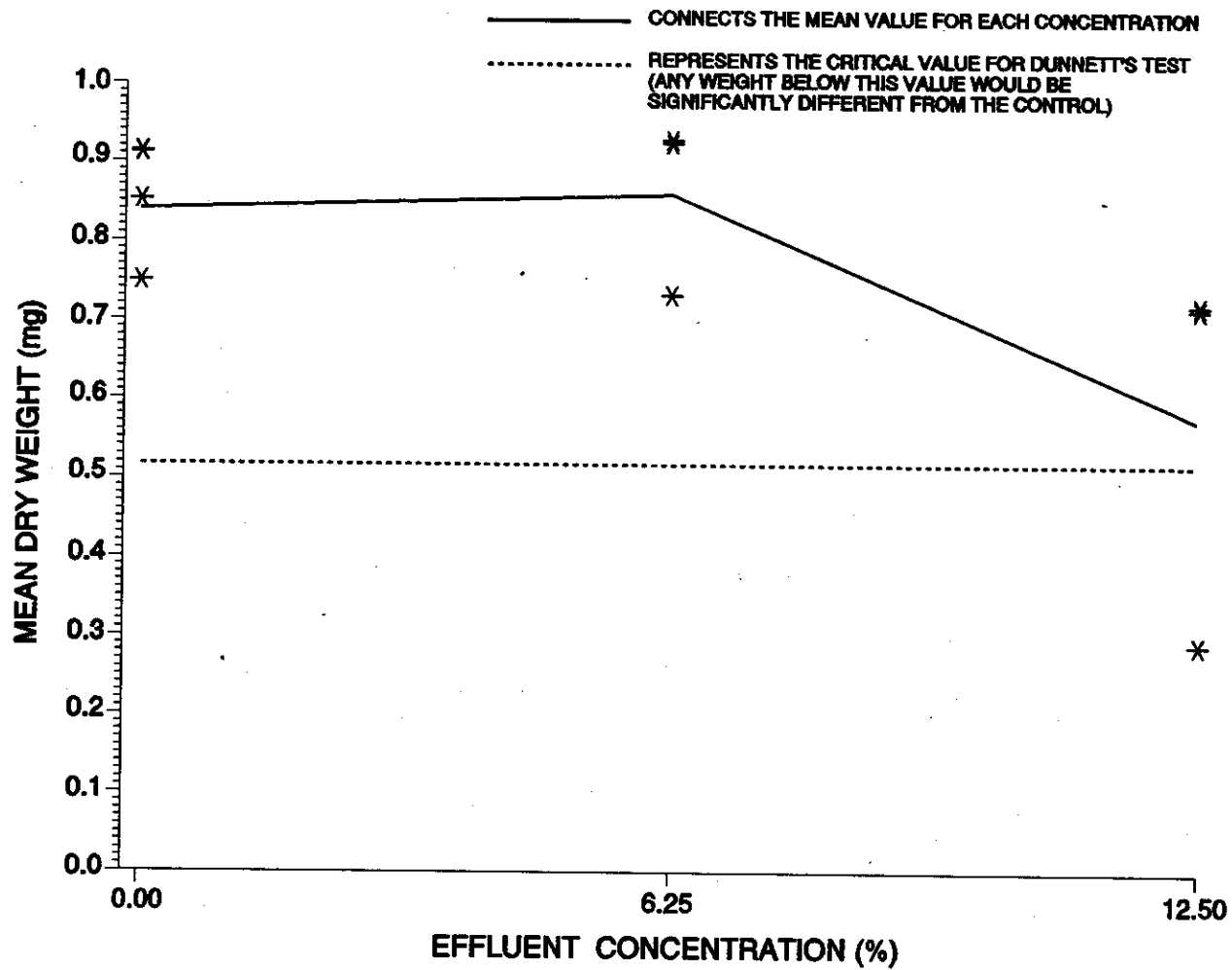

Figure 11. Plot of mean weights of inland silverside, *Menidia beryllina*, larval survival and growth test.

13.13.3.5.2 Calculate the denominator, D, of the test statistic:

$$D = \sum_{i=1}^n (X_i - \bar{X})^2$$

Where: X_i = the i th centered observation

\bar{X} = the overall mean of the centered observations

n = the total number of centered observations.

For this set of data,

$$n = 9$$

$$\bar{X} = \frac{1}{9}(-0.002) = 0.000$$

$$D = 0.167$$

13.13.3.5.3 Order the centered observations from smallest to largest:

$$X^{(1)} \leq X^{(2)} \leq \dots \leq X^{(n)}$$

Where $X^{(i)}$ is the i th ordered observation. These ordered observations are listed in Table 14.

TABLE 14. ORDERED CENTERED OBSERVATIONS FOR SHAPIRO-WILK'S EXAMPLE

i	$X^{(i)}$	i	$X^{(i)}$
1	-0.290	6	0.071
2	-0.117	7	0.116
3	-0.085	8	0.143
4	0.000	9	0.147
5	0.013		

13.13.3.5.4 From Table 4, Appendix B, for the number of observations, n , obtain the coefficients a_1, a_2, \dots, a_k where k is $n/2$ if n is even and $(n-1)/2$ if n is odd. For the data in this example, $n = 9$ and $k = 4$. The a_i values are listed in Table 15.

13.13.3.5.5 Compute the test statistic, W, as follows:

$$W = \frac{1}{D} \left[\sum_{i=1}^k a_i (X^{(n-i+1)} - X^{(i)}) \right]^2$$

The differences $X^{(n-i+1)} - X^{(i)}$ are listed in Table 15. For this set of data:

$$W = \frac{1}{0.1657} (0.3997)^2 = 0.964$$

TABLE 15. COEFFICIENTS AND DIFFERENCES FOR SHAPIRO-WILK'S EXAMPLE

i	a_i	$X^{(n-i+1)} - X^{(i)}$	
1	0.5888	0.437	$X^{(9)} - X^{(1)}$
2	0.3244	0.260	$X^{(8)} - X^{(2)}$
3	0.1976	0.201	$X^{(7)} - X^{(3)}$
4	0.0947	0.071	$X^{(6)} - X^{(4)}$

13.13.3.5.6 The decision rule for this test is to compare W with the critical value found in Table 6, Appendix B. If the computed W is less than the critical value, conclude that the data are not normally distributed. For this example, the critical value at a significance level of 0.01 and nine observations (n) is 0.764. Since $W = 0.964$ is greater than the critical value, the conclusion of the test is that the data are normally distributed.

13.13.3.6 Test for Homogeneity of Variance

13.13.3.6.1 The test used to examine whether the variation in mean dry weight is the same across all effluent concentrations including the control, is Bartlett's Test (Snedecor and Cochran, 1980). The test statistic is as follows:

$$B = \frac{[(\sum_{i=1}^p V_i) 1n \bar{S}^2 - \sum_{i=1}^p V_i 1n S_i^2]}{C}$$

Where: V_i = degrees of freedom for each effluent concentration and control, $V_i = (n_i - 1)$

p = number of levels of effluent concentration including the control

$i = 1, 2, \dots, p$ where p is the number of concentrations including the control

$\ln = \log_e$

$n_i =$ number of replicates for concentration i

$$\bar{S}^2 = \frac{(\sum_{i=1}^p V_i S_i^2)}{\sum_{i=1}^p V_i}$$

$$C = 1 + [3(p-1)]^{-1} \left[\sum_{i=1}^p 1/V_i - (\sum_{i=1}^p V_i)^{-1} \right]$$

13.13.3.6.2 For the data in this example, (See Table 13) all effluent concentrations including the control have the same number of replicates ($n_i = 3$ for all i). Thus, $V_i = 2$ for all i .

13.13.3.6.3 Bartlett's statistic is therefore:

$$\begin{aligned} B &= [(6) \ln(0.274) - 2 \sum_{i=1}^p \ln(S_i^2)] / 1.25 \\ &= [6(-3.5972) - 2(\ln(0.0062) + \ln(0.0130) + \ln(0.0631))] / 1.25 \\ &= [-26.583 - (-24.378)] / 1.25 \\ &= 2.236 \end{aligned}$$

13.13.3.6.4 B is approximately distributed as chi-square with $p - 1$ degrees of freedom, when the variances are in fact the same. Therefore, the appropriate critical value for this test, at a significance level of 0.01 with 2 degrees of freedom, is 9.210. Since $B = 2.236$ is less than the critical value of 9.210, conclude that the variances are not different.

13.13.3.7 Dunnett's Procedure

13.13.3.7.1 To obtain an estimate of the pooled variance for the Dunnett's Procedure, construct an ANOVA table as described in Table 16.

TABLE 16. ANOVA TABLE

Source	df	Sum of Squares (SS)	Mean Square (MS) (SS/df)
Between	p - 1	SSB	$S_B^2 = SSB/(p-1)$
Within	N - p	SSW	$S_W^2 = SSW/(N-p)$
Total	N - 1	SST	

Where: p = number of effluent concentrations including the control

N = total number of observations $n_1 + n_2 \dots + n_p$

n_i = number of observations in concentration i

$$SSB = \sum_{i=1}^p T_i^2/n_i - G^2/N \quad \text{Between Sum of Squares}$$

$$SST = \sum_{i=1}^p \sum_{j=1}^{n_i} Y_{ij}^2 - G^2/N \quad \text{Total Sum of Squares}$$

$$SSW = SST - SSB \quad \text{Within Sum of Squares}$$

$$G = \text{the grand total of all sample observations,} \quad G = \sum_{i=1}^p T_i$$

T_i = the total of the replicate measurements for concentration i

Y_{ij} = the jth observation for concentration i (represents the mean dry weight of the fish for toxicant concentration i in test chamber j)

13.13.3.7.2 For the data in this example:

$$n_1 = n_2 = n_3 = 3$$

$$N = 9$$

$$T_1 = Y_{11} + Y_{12} + Y_{13} = 0.751 + 0.849 + 0.907 = 2.507$$

$$T_2 = Y_{21} + Y_{22} + Y_{23} = 0.727 + 0.922 + 0.927 = 2.576$$

$$T_3 = Y_{31} + Y_{32} + Y_{33} = 0.722 + 0.285 + 0.718 = 1.725$$

$$G = T_1 + T_2 + T_3 = 6.808$$

$$\begin{aligned} SSB &= \sum_{i=1}^p T_i^2/n_i - G^2/N \\ &= \frac{1}{3}(15.896) - \frac{(6.808)^2}{9} = 0.1488 \end{aligned}$$

$$\begin{aligned} SST &= \sum_{i=1}^p \sum_{j=1}^{n_i} Y_{ij}^2 - G^2/N \\ &= 5.463 - \frac{(6.808)^2}{9} = 0.3131 \end{aligned}$$

$$SSW = SST - SSB = 0.3131 - 0.1488 = 0.1643$$

$$S_B^2 = SSB/(p-1) = 0.1488/(3-1) = 0.0744$$

$$S_W^2 = SSW/(N-p) = 0.1643/(9-3) = 0.0274$$

13.13.3.7.3 Summarize these calculations in the ANOVA table (Table 17).

TABLE 17. ANOVA TABLE FOR DUNNETT'S PROCEDURE EXAMPLE

Source	df	Sum of Squares (SS)	Mean Square (MS) (SS/df)
Between	2	0.1488	0.0744
Within	6	0.1643	0.0274
Total	8	0.3131	

13.13.3.7.4 To perform the individual comparisons, calculate the t statistic for each concentration and control combination as follows:

$$t_i = \frac{(\bar{Y}_1 - \bar{Y}_i)}{S_w \sqrt{(1/n_1) + (1/n_i)}}$$

Where: Y_i = mean dry weight for effluent concentration i

\bar{Y}_1 = mean dry weight for the control

S_w = square root of the within mean square

n_1 = number of replicates for the control

n_i = number of replicates for concentration i.

13.13.3.7.5 Table 18 includes the calculated t values for each concentration and control combination. In this example, comparing the 6.25% concentration with the control the calculation is as follows:

$$t_2 = \frac{(0.836 - 0.859)}{[0.1655\sqrt{(1/3) + (1/3)}]} = -0.120$$

TABLE 18. CALCULATED T VALUES

Effluent Concentration (%)	i	t_i
6.25	2	-0.170
12.5	3	1.931

13.13.3.7.6 Since the purpose of this test is to detect a significant reduction in mean weight, a one-sided test is appropriate. The critical value for this one-sided test is found in Table 5, Appendix C. For an overall alpha level of 0.05, six degrees of freedom for error and two concentrations (excluding the control) the critical value is 2.34. The mean weight for concentration i is considered significantly less than mean weight for the control if t_i is greater than the critical value. Therefore, all effluent concentrations in this example do not have significantly lower mean weights than the control. Hence the NOEC and the LOEC for growth cannot be calculated.

13.13.3.7.7 To quantify the sensitivity of the test, the minimum significant difference (MSD) that can be detected statistically may be calculated.

$$MSD = d S_w \sqrt{(1/n_1) + (1/n)}$$

Where: d = the critical value for Dunnett's Procedure

S_w = the square root of the within mean square

n = the common number of replicates at each concentration
(this assumes equal replication at each concentration)

n_1 = the number of replicates in the control.

13.13.3.7.8 In this example:

$$\begin{aligned} MSD &= 2.34 (0.1655) \sqrt{(1/3) + (1/3)} \\ &= 2.34 (0.1655) (0.8165) \\ &= 0.316 \end{aligned}$$

13.13.3.7.9 Therefore, for this set of data, the *minimum difference* that can be detected as statistically significant is 0.316 mg.

13.13.3.7.10 This represents a 37.8% reduction in mean weight from the control.

13.13.3.8 Calculation of the ICp

13.13.3.8.1 The growth data from Tables 4 and 12 are utilized in this example. As seen in Table 19 and Figure 11, the observed means are not monotonically non-increasing with respect to concentration (the mean response for each higher concentration is not less than or equal to the mean response for the previous concentration, and the responses between concentrations do not follow a linear trend). Therefore, the means are smoothed prior to calculating the IC. In the following discussion, the observed means are represented by \bar{Y}_i and the smoothed means by M_i .

13.13.3.8.2 Starting with the control mean, $\bar{Y}_1 = 0.836$ and $\bar{Y}_2 = 0.859$, we see that $\bar{Y}_1 < \bar{Y}_2$. Set $M_i = \bar{Y}_i$.

13.13.3.8.3 Calculate the smoothed means:

$$M_1 = M_2 = (\bar{Y}_1 + \bar{Y}_2)/2 = 0.847$$

13.13.3.8.4 Since $\bar{Y}_5 = 0 < \bar{Y}_4 = 0.196 < \bar{Y}_3 = 0.575 < M_2$, set $M_3 = 0.575$, $M_4 = 0.196$, and $M_5 = 0$.

13.13.3.8.5 Table 19 contains the response means and the smoothed means and Figure 12 gives a plot of the smoothed response curve.

TABLE 19. INLAND SILVERSIDE MEAN GROWTH RESPONSE AFTER SMOOTHING

Effluent Conc. (%)	i	Response Means, Y_i (mg)	Smoothed Means, M_i (mg)
Control	1	0.836	0.847
6.25	2	0.859	0.847
12.50	3	0.575	0.575
25.00	4	0.196	0.196
50.00	5	0.00	0.0

13.13.3.8.6 An IC25 and IC50 can be estimated using the Linear Interpolation Method. A 25% reduction in weight, compared to the controls, would result in a mean dry weight of 0.627 mg, where $M_1(1-p/100) = 1.847(1-25/100)$. A 50% reduction in mean dry weight, compared to the controls, would result in a mean weight of 0.418 mg. Examining the smoothed means and their associated concentrations (Table 20), the response, 0.627 mg, is bracketed by $C_2 = 6.25\%$ effluent and $C_3 = 25.0\%$ effluent. The response (0.418) is bracketed by $C_3 = 12.5\%$ and by $C_4 = 25\%$ effluent.

13.13.3.8.7 Using the equation from Section 4.2 of Appendix L, the estimate of the IC25 is calculated as follows:

$$ICp = C_j + [M_1(1-p/100) - M_j] \frac{(C_{j+1} - C_j)}{(M_{j+1} - M_j)}$$

$$\begin{aligned} IC25 &= 6.25 + [0.847(1 - 25/100) - 0.847] \frac{(12.50 - 6.25)}{(0.575 - 0.847)} \\ &= 11.1\% \end{aligned}$$

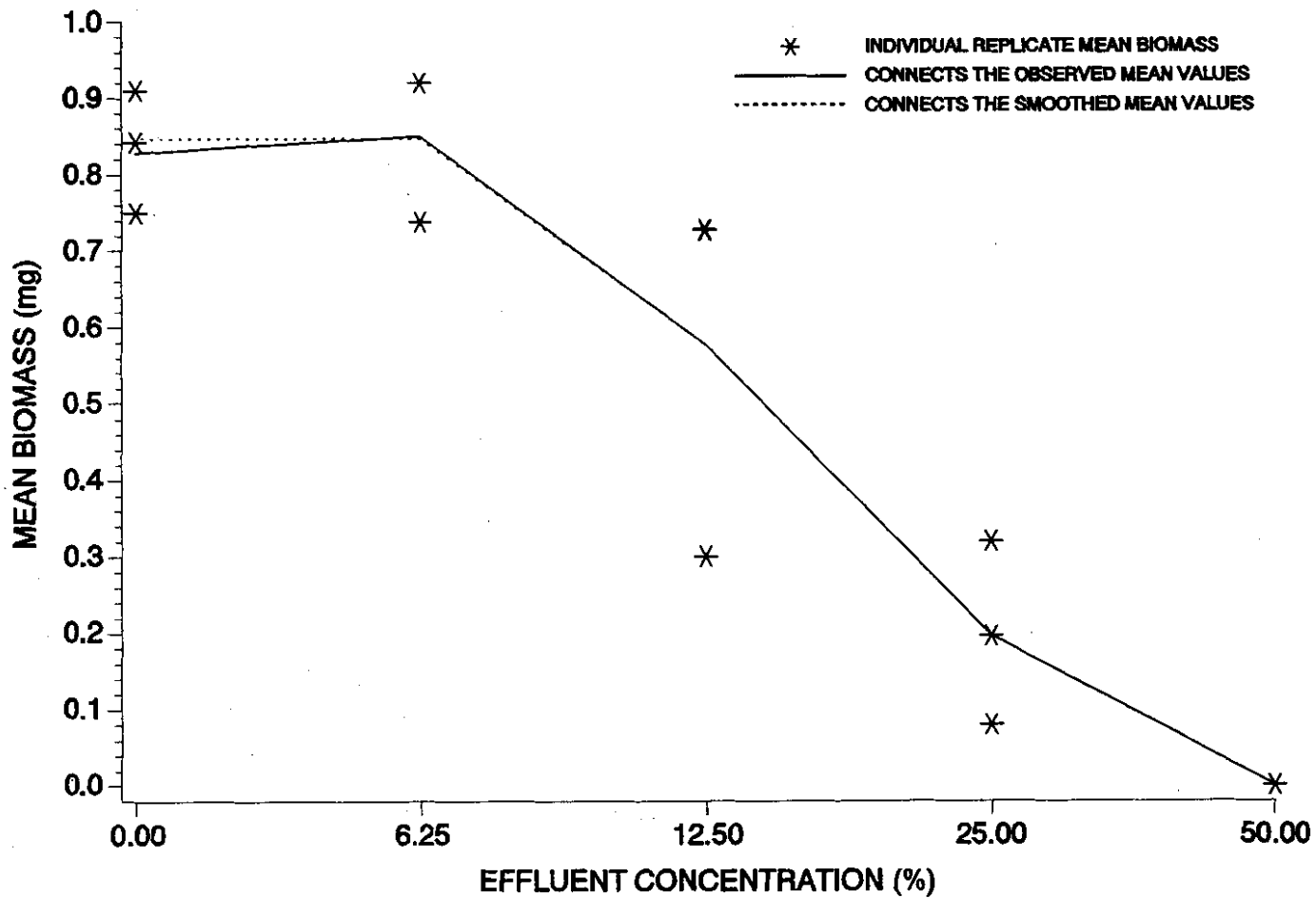

Figure 12. Plot of the raw data, observed means, and smoothed means from Tables 13 and 19.

13.13.3.8.8 Using the equation from Section 4.2 of Appendix L, the estimate of the IC50 is calculated as follows:

$$ICp = C_j + [M_1(1-p/100) - M_j] \frac{(C_{j+1} - C_j)}{(M_{j+1} - M_j)}$$

$$\begin{aligned} IC50 &= 6.25 + [0.847(1 - 50/100) - 0.847] \frac{(12.50 - 6.25)}{(0.575 - 0.847)} \\ &= 17.5\%. \end{aligned}$$

13.13.3.8.9 When the ICPIN program was used to analyze this set of data, requesting 80 resamples, the estimate of the IC25 was 11.1136%. The empirical 95% confidence interval for the true mean was 5.7119% to 19.2112%. The computer program output for the IC25 for this data set is shown in Figure 13.

13.13.3.8.10 When the ICPIN program was used to analyze this set of data for the IC50, requesting 80 resamples, the estimate of the IC50 was 17.4896%. The empirical 95% confidence interval for the true mean was 6.4891% to 22.4754% effluent. The computer program output is shown in Figure 14.

13.14 PRECISION AND ACCURACY

13.14.1 PRECISION

13.14.1.1 Single-Laboratory Precision

13.14.1.1.1 Data on the single-laboratory precision of the inland silverside larval survival and growth test using copper (CU) sulfate and sodium dodecyl sulfate (SDS) as reference toxicants, in natural seawater and GP2 are provided in Tables 20-22. In Tables 20-21, the coefficient of variation for copper based on the IC25 is 43.2% and for SDS is 43.2% indicating acceptable precision. In the five tests with each reference toxicant, the NOEC's varied by only one concentration interval, indicating good precision. The coefficient of variation for all reference toxicants based on the IC50 in two types of seawater (GP2 and natural) ranges from 1.8% to 50.7% indicating acceptable precision. Data in Table 22 show no detectable differences between tests conducted in natural and artificial seawaters.

13.14.1.2 Multilaboratory Precision

13.14.1.2.1 Data on the multilaboratory precision of the inland silverside larval survival and growth test are not yet available.

13.14.2 ACCURACY

13.14.2.1 The accuracy of toxicity tests cannot be determined.

Conc. ID	1	2	3	4	5	6
Conc. Tested	0	6.25	12.5	25	50	100
Response 1	.751	.727	.722	.196	0	0
Response 2	.849	.922	.285	.312	0	0
Response 3	.907	.927	.718	.079	0	0

*** Inhibition Concentration Percentage Estimate ***

Toxicant/Effluent: Effluent
 Test Start Date: Test Ending Date:
 Test Species: Menidia beryllina
 Test Duration: 7-d
 DATA FILE: silver.icp
 OUTPUT FILE: silver.i25

Conc. ID	Number Replicates	Concentration %	Response Means	Std. Dev.	Pooled Response Means
1	3	0.000	0.836	0.079	0.847
2	3	6.250	0.859	0.114	0.847
3	3	12.500	0.575	0.251	0.575
4	3	25.000	0.196	0.117	0.196
5	3	50.000	0.000	0.000	0.000
6	3	100.000	0.000	0.000	0.000

The Linear Interpolation Estimate: 11.1136 Entered P Value: 25

Number of Resamplings: 80
 The Bootstrap Estimates Mean: 11.5341 Standard Deviation: 2.1155
 Original Confidence Limits: Lower: 8.5413 Upper: 14.9696
 Expanded Confidence Limits: Lower: 5.7119 Upper: 19.2112
 Resampling time in Seconds: 1.43 Random Seed: -1912403737

Figure 13. ICPIN program output for the IC25.

Conc. ID	1	2	3	4	5	6
Conc. Tested	0	6.25	12.5	25	50	100
Response 1	.751	.727	.722	.196	0	0
Response 2	.849	.922	.285	.312	0	0
Response 3	.907	.927	.718	.079	0	0

*** Inhibition Concentration Percentage Estimate ***

Toxicant/Effluent: Effluent
 Test Start Date: Test Ending Date:
 Test Species: Menidia beryllina
 Test Duration: 7-d
 DATA FILE: silver.icp
 OUTPUT FILE: silver.i50

Conc. ID	Number Replicates	Concentration %	Response Means	Std. Dev.	Pooled Response Means
1	3	0.000	0.836	0.079	0.847
2	3	6.250	0.859	0.114	0.847
3	3	12.500	0.575	0.251	0.575
4	3	25.000	0.196	0.117	0.196
5	3	50.000	0.000	0.000	0.000
6	3	100.000	0.000	0.000	0.000

The Linear Interpolation Estimate: 17.4896 Entered P Value: 50

Number of Resamplings: 80
 The Bootstrap Estimates Mean: 16.9032 Standard Deviation: 2.4973
 Original Confidence Limits: Lower: 12.2513 Upper: 19.8638
 Expanded Confidence Limits: Lower: 6.4891 Upper: 22.4754
 Resampling time in Seconds: 1.43 Random Seed: -1440337465

Figure 14. ICPIN program output for the IC50.

TABLE 20. SINGLE-LABORATORY PRECISION OF THE INLAND SILVERSIDE, *MENIDIA BERYLLINA*, SURVIVAL AND GROWTH TEST PERFORMED IN NATURAL SEAWATER, USING LARVAE FROM FISH MAINTAINED AND SPAWNED IN NATURAL SEAWATER, AND COPPER (CU) AS A REFERENCE TOXICANT^{1,2,3,4,5,6,7}

Test Number	NOEC (µg/L)	IC25 (µg/L)	IC50 (µg/L)	Most Sensitive Endpoint
1	63	96.2	148.6	S
2	125	207.2	NC ^d	S
3	63	218.9	493.4	G
4	125	177.5	241.4	S
5	31	350.1	479.8	G
n:	5	5	4	
Mean:	NA	209.9	340.8	
CV(%):	NA	43.7	50.7	

¹ Data from USEPA (1988a) and USEPA (1991a)

² Tests performed by George Morrison and Elise Torello, ERL-N, USEPA, Narragansett, RI.

³ Three replicate exposure chambers with 10-15 larvae were used for the control and each copper concentration. Copper concentrations were: 31, 63, 125, 250, and 500 µg/L.

⁴ Adults collected in the field.

⁵ S = Survival effects. G = Growth data at these toxicant concentrations were disregarded because there was a significant reduction in survival.

⁶ NOEC Range: 31 - 125 µg/L (this represents a difference of two exposure concentrations).

⁷ For a discussion of the precision of data from chronic toxicity tests see Section 4, Quality Assurance.

⁸ NC = No linear interpolation estimate could be calculated from the data, since none of the group response means were less than 50 percent of the control response mean.

TABLE 21. SINGLE-LABORATORY PRECISION OF THE INLAND SILVERSIDE, *MENIDIA BERYLLINA*, SURVIVAL AND GROWTH TEST PERFORMED IN NATURAL SEAWATER, USING LARVAE FROM FISH MAINTAINED AND SPAWNED IN NATURAL SEAWATER, AND SODIUM DODECYL SULFATE (SDS) AS A REFERENCE TOXICANT^{1,2,3,4,5,6,7}

Test Number	NOEC (mg/L)	IC25 (mg/L)	IC50 (mg/L)	Most Sensitive Endpoint
1	1.3	0.3	1.7	S
2	1.3	1.6	1.9	S
3	1.3	1.5	1.9	S
4	1.3	1.5	1.9	S
5	1.3	1.6	2.2	S
n:	5	5	5	
Mean:	NA	1.3	1.9	
CV(%):	NA	43.2	9.4	

¹ Data from USEPA (1988a) and USEPA (1991a)

² Tests performed by George Morrison and Elise Torello, ERL-N, USEPA, Narragansett, RI.

³ Three replicate exposure chambers with 10-15 larvae were used for the control and each SDS concentration. SDS concentrations were: 0.3, 0.6, 1.3, 2.5, and 5.0 mg/L.

⁴ Adults collected in the field.

⁵ S = Survival Effects. Growth data at these toxicant concentrations were disregarded because there was a significant reduction in survival.

⁶ NOEC Range 1.3 mg/L.

⁷ For a discussion of the precision of data from chronic toxicity tests see Section 4, Quality Assurance.

TABLE 22. COMPARISON OF THE SINGLE-LABORATORY PRECISION OF THE INLAND SILVERSIDE, *MENIDIA BERYLLINA*, LARVAL SURVIVAL (LC50) AND GROWTH (IC50) VALUES EXPOSED TO SODIUM DODECYL SULFATE (SDS) OR COPPER (CU) SULFATE IN GP2 ARTIFICIAL SEAWATER MEDIUM OR NATURAL SEAWATER (NSW)^{1,2,3,4}

SDS (mg/L)	Survival		Growth	
	GP2	NSW	GP2	NSW
	3.59	3.69	3.60	3.55
	4.87	4.29	5.54	5.27
	5.95	8.05	6.70	8.53
Mean	4.81	5.34	5.28	5.79
CV (%)	24.6	44.2	29.6	43.8
Copper ($\mu\text{g/L}$)	GP2	NSW	GP2	NSW
	247	256	260	277
	215	211	236	223
	268	240	NC ⁵	238
Mean	243	236	248	246
CV (%)	10.9	9.8	6.9	11.2

¹ Tests performed by George Morrison and Glen Modica, ERL-N, USEPA, Narragansett, RI.

² Three replicate exposure chambers with 10-15 larvae per treatment.

³ Adults collected in the field.

⁴ For a discussion of the precision of data from chronic toxicity tests see Section 4, Quality Assurance.

⁵ NC= No linear interpolation estimate could be calculated from the data, since none of the group response means were less than 50 percent of the control response mean.

SECTION 14

TEST METHOD

MYSID, *MYSIDOPSIS BAHIA*, SURVIVAL, GROWTH, AND FECUNDITY TEST METHOD 1007.0

14.1 SCOPE AND APPLICATION

14.1.1 This method, adapted in part from USEPA (1987d), estimates the chronic toxicity of effluents and receiving waters to the mysid, *Mysidopsis bahia*, during a seven-day, static renewal exposure. The effects include the synergistic, antagonistic, and additive effects of all the chemical, physical, and additive components which adversely affect the physiological and biochemical functions of the test organisms.

14.1.2 Daily observations on mortality make it possible to also calculate acute toxicity for desired exposure periods (i.e., 24-h, 48-h, 96-h LC50s).

14.1.3 Detection limits of the toxicity of an effluent or pure substance are organism dependent.

14.1.4 Brief excursions in toxicity may not be detected using 24-h composite samples. Also, because of the long sample collection period involved in composite sampling and because the test chambers are not sealed, highly volatile and highly degradable toxicants present in the source may not be detected in the test.

14.1.5 This test is commonly used in one of two forms: (1) a definitive test, consisting of a minimum of five effluent concentrations and a control, and (2) a receiving water test(s), consisting of one or more receiving water concentrations and a control.

14.2 SUMMARY OF METHOD

14.2.1 *Mysidopsis bahia* 7-day old juveniles are exposed to different concentrations of effluent, or to receiving water in a static system, during the period of egg development. The test endpoints are survival, growth (measured as dry weight), and fecundity (measured as the percentage of females with eggs in the oviduct and/or brood pouch).

14.3 INTERFERENCES

14.3.1 Toxic substances may be introduced by contaminants in dilution water, glassware, sample hardware, and testing equipment (see Section 5, Facilities, Equipment, and Supplies).

14.3.2 Improper effluent sampling and handling may adversely affect test results (see Section 8, Effluent and Receiving Water Sampling, Sample Handling, and Sample Preparation for Toxicity Tests).

14.3.3 The test results can be confounded by (1) the presence of pathogenic and/or predatory organisms in the dilution water, effluent, and receiving water, (2) the condition of the brood stock from which the test animals were taken, (3) the amount and type of natural food in the effluent, receiving water, or dilution water, (4) nutritional value of the brine shrimp, *Artemia* nauplii, fed during the test, and (5) the quantity of brine shrimp, *Artemia* nauplii, or other food added during the test, which may sequester metals and other toxic substances, and lower the DO.

14.4 SAFETY

14.4.1 See Section 3, Health and Safety.

14.5 APPARATUS AND EQUIPMENT

14.5.1 Facilities for holding and acclimating test organisms.

14.5.2 Brine shrimp, *Artemia*, culture unit -- see Subsection 14.6.12 below and Section 4, Quality Assurance.

14.5.3 Mysid, *Mysidopsis bahia*, culture unit -- see Subsection 6 below. This test requires a minimum of 240 7-day old (juvenile) mysids. It is preferable to obtain the test organisms from an in-house culture unit. If it is not feasible to culture mysids in-house, juveniles can be obtained from other sources, if shipped in well oxygenated saline water in insulated containers.

14.5.4 Samplers -- automatic sampler, preferably with sample cooling capability, that can collect a 24-h composite sample of 5 L.

14.5.5 Environmental chamber or equivalent facility with temperature control ($26 \pm 1^\circ\text{C}$).

14.5.6 Water purification system -- Millipore Milli-Q®, deionized water or equivalent.

14.5.7 Balance -- Analytical, capable of accurately weighing to 0.00001 g.

14.5.8 Reference weights, Class S -- for checking performance of balance. Weights should bracket the expected weights of the weighing pans and weighing pans plus organisms.

14.5.9 Drying oven -- 50-105°C range, for drying organisms.

14.5.10 Desiccator -- for holding dried organisms.

14.5.11 Air pump -- for oil-free air supply.

14.5.12 Air lines, and air stones -- for aerating cultures, brood chambers, and holding tanks, and supplying air to test solutions with low DO.

14.5.13 Meters, pH and DO -- for routine physical and chemical measurements.

- 14.5.14 Tray -- for test vessels; approximately 90 X 48 cm to hold 56 vessels.
- 14.5.15 Standard or micro-Winkler apparatus -- for determining DO and checking DO meters.
- 14.5.16 Dissecting microscope (350-400X magnification) -- for examining organisms in the test vessels to determine their sex and to check for the presence of eggs in the oviducts of the females.
- 14.5.17 Light box -- for illuminating organisms during examination.
- 14.5.18 Refractometer or other method -- for determining salinity.
- 14.5.19 Thermometers, glass or electronic, laboratory grade -- for measuring water temperatures.
- 14.5.20 Thermometers, bulb-thermograph or electronic-chart type -- for continuously recording temperature.
- 14.5.21 Thermometer, National Bureau of Standards Certified (see USEPA Method 170.1, USEPA, 1979b) -- to calibrate laboratory thermometers.
- 14.5.22 Test chambers -- 200 mL borosilicate glass beakers or non-toxic 8 oz disposable plastic cups (manufactured by Falcon Division of Becton, Dickinson Co., 1950 Williams Dr., Oxnard, CA 93030) or other similar containers. Forty-eight (48) test vessels are required for each test (eight replicates at each of five effluent concentrations and a control). To avoid potential contamination from the air and excessive evaporation of test solutions during the test, the chambers should be covered with safety glass plates or sheet plastic (6 mm thick).
- 14.5.23 Beakers or flasks -- six, borosilicate glass or non-toxic plasticware, 2000 mL for making test solutions.
- 14.5.24 Wash bottles -- for deionized water, for washing organisms from containers and for rinsing small glassware and instrument electrodes and probes.
- 14.5.25 Volumetric flasks and graduated cylinders -- Class A, borosilicate glass or non-toxic plastic labware, 50-2000 mL for making test solutions.
- 14.5.26 Separatory funnels, 2-L -- Two-four for culturing *Artemia*.
- 14.5.27 Pipets, volumetric -- Class A, 1-100 mL.
- 14.5.28 Pipets, automatic -- adjustable, 1-100 mL.
- 14.5.29 Pipets, serological -- 1-10 mL, graduated.
- 14.5.30 Pipet bulbs and fillers -- PROPIPET®, or equivalent.

14.5.31 Droppers, and glass tubing with fire polished edges, 4 mm ID -- for transferring organisms.

14.5.32 Forceps -- for transferring organisms to weighing pans.

14.5.33 NITEX® or stainless steel mesh sieves ($\leq 150 \mu\text{m}$, 500-1000 μm , 3-5 mm) -- for concentrating organisms. (NITEX® is available from Sterling Marine Products, 18 Label Street, Montclair, NJ 07042; 201-783-9800).

14.5.34 Depression glass slides or depression spot plates -- two, for observing organisms.

14.6 REAGENTS AND CONSUMABLE MATERIALS

14.6.1 Sample containers -- for sample shipment and storage (see Section 8, Effluent and Receiving Water Sampling, Sample Handling, and Sample Preparation for Toxicity Tests).

14.6.2 Data sheets (one set per test) -- for data recording (Figures 14, 15, and 16).

14.6.3 Tape, colored -- for labelling test chambers.

14.6.4 Markers, waterproof -- for marking containers, etc.

14.6.5 Weighing pans, aluminum -- to determine the dry weight of organisms.

14.6.6 Buffers, pH 4, pH 7, and pH 10 (or as per instructions of instrument manufacturer) -- for standards and calibration check (see USEPA Method 150.1, USEPA, 1979b).

14.6.7 Membranes and filling solutions -- for dissolved oxygen probe (see USEPA Method 360.1, USEPA, 1979b), or reagents for modified Winkler analysis.

14.6.8 Laboratory quality assurance samples and standards -- for the above methods.

14.6.9 Reference toxicant solutions -- see Section 4, Quality Assurance.

14.6.10 Reagent water -- defined as distilled or deionized water that does not contain substances which are toxic to the test organisms (see Section 5, Facilities, Equipment, and Supplies).

14.6.11 Effluent, receiving water, and dilution water -- see Section 7, Dilution Water, and Section 8, Effluent and Receiving Water Sampling, Sample Handling, and Sample Preparation for Toxicity Tests. Dilution water containing organisms that might prey upon or otherwise interfere with the test organisms should be filtered through a fine mesh net (with 150 μm or smaller openings).

14.6.11.1 Saline test and dilution water -- The salinity of the test water must be in the range of 20‰ to 30‰. The salinity should vary by no more

than $\pm 2\%$ among the chambers on a given day. If effluent and receiving water tests are conducted concurrently, the salinities of these tests should be similar.

14.6.11.2 The overwhelming majority of industrial and sewage treatment effluents entering marine and estuarine systems contain little or no measurable salts. Exposure of mysids to these effluents will require adjustments in the salinity of the test solutions. It is important to maintain a constant salinity across all treatments. In addition, it may be desirable to match the test salinity with that of the receiving water. Two methods are available to adjust salinities -- a hypersaline brine (HSB) derived from natural seawater or artificial sea salts.

14.6.11.3 HSB has several advantages that make it desirable for use in toxicity testing. It can be made from any high quality, filtered seawater by evaporation, and can be added to the effluent or to deionized water to increase the salinity. Brine derived from natural seawater contains the necessary trace metals, biogenic colloids, and some of the microbial components necessary for adequate growth, survival, and/or reproduction of marine and estuarine organisms, and may be stored for prolonged periods without any apparent degradation. However, if 100% HSB is used as a diluent, the maximum concentration of effluent that can be tested is 80% effluent at 30% salinity and 70% effluent at 30% salinity.

14.6.11.3.1 The ideal container for making brine from natural seawater is one that (1) has a high surface to volume ratio, (2) is made of a non-corrosive material, and (3) is easily cleaned (fiberglass containers are ideal). Special care should be used to prevent any toxic materials from coming in contact with the seawater being used to generate the brine. If a heater is immersed directly into the seawater, ensure that the heater materials do not corrode or leach any substances that would contaminate the brine. One successful method used is a thermostatically controlled heat exchanger made from fiberglass. If aeration is used, only oil-free air compressors should be used to prevent contamination.

14.6.11.3.2 Before adding seawater to the brine generator, thoroughly clean the generator, aeration supply tube, heater, and any other materials that will be in direct contact with the brine. A good quality biodegradable detergent should be used, followed by several (at least three) thorough deionized water rinses.

14.6.11.3.3 High quality (and preferably high salinity) seawater should be filtered to at least $10 \mu\text{m}$ before placing into the brine generator. Water should be collected on an incoming tide to minimize the possibility of contamination.

14.6.11.3.4 The temperature of the seawater is increased slowly to 40°C . The water should be aerated to prevent temperature stratification and to increase water evaporation. The brine should be checked daily (depending on the volume being generated) to ensure that the salinity does not exceed 100% and that the temperature does not exceed 40°C . Additional seawater may be added to the brine to obtain the volume of brine required.

14.6.11.3.5 After the required salinity is attained, the HSB should be filtered a second time through a 1 μ m filter and poured directly into portable containers (20-L cubitainers or polycarbonate water cooler jugs are suitable). The containers should be capped and labelled with the date the brine was generated and its salinity. Containers of HSB should be stored in the dark and maintained under room temperature until used.

14.6.11.3.6 If a source of HSB is available, test solutions can be made by following the directions below. Thoroughly mix together the deionized water and HSB before mixing in the effluent.

14.6.11.3.7 Divide the salinity of the HSB by the expected test salinity to determine the proportion of deionized water to brine. For example, if the salinity of the brine is 100‰ and the test is to be conducted at 20‰, 100‰ divided by 20‰ = 5.0. The proportion of brine is 1 part in 5 (one part brine to four parts deionized water). To make 1 L of seawater at 20‰ salinity from a HSB of 100‰, 200 mL of brine and 800 mL of deionized water are required.

14.6.11.3.8 Table 2 illustrates the composition of 1800 mL test solutions at 20‰ if they are made by combining effluent (0‰), deionized water and HSB of 100‰ (only). The volume (mL) of brine required is determined by using the amount calculated above. In this case, 200 mL of brine is required for 1 L; therefore, 360 mL would be required for 1.8 L of solution. The volumes of HSB required are constant. The volumes of deionized water are determined by subtracting the volumes of effluent and brine from the total volume of solution: 1800 mL - mL effluent - mL brine = mL deionized water.

14.6.11.4 Artificial sea salts: FORTY FATHOMS® brand sea salts (Marine Enterprises, Inc., 8755 Mylander Lane, Baltimore, MD 21204; 301-321-1189) have been used successfully to culture and perform life cycle tests with mysids (Horne, et al., 1983; ASTM, 1993)(see Section 7, Dilution Water). HW Marinemix® (Hawaiian Marine Imports, Inc., P.O. Box 218687, Houston, TX 77218; 713-492-7864 sea salts have been used successfully to culture mysids and perform the mysid toxicity test (USEPA Region 6 Houston Laboratory; EMSL-Cincinnati). In addition, a slightly modified version of the GP2 medium (Spotte et al., 1984) has been successfully used to perform the mysid survival, growth, and fecundity test (Table 1).

14.6.11.4.1 Synthetic sea salts are packaged in plastic bags and mixed with deionized water or equivalent. The instructions on the package of sea salts should be followed carefully, and the salts should be mixed in a separate container -- not in the culture tank. The deionized water used in hydration should be in the temperature range of 21-26°C. Seawater made from artificial sea salts is conditioned (Spotte, 1973; Spotte, et al., 1984; Bower, 1983) before it is used for culturing or testing. After adding the water, place an airstone in the container, cover, and aerate the solution mildly for 24 h before use.

14.6.11.4.2 The GP2 reagent grade chemicals (Table 1) should be mixed with deionized (DI) water or its equivalent in a container other than the culture or testing tanks. The deionized water used for hydration should be between 21-26°C. The artificial seawater must be conditioned (aerated) for 24 h

TABLE 1. REAGENT GRADE CHEMICALS USED IN THE PREPARATION OF GP2 ARTIFICIAL SEAWATER FOR THE MYSID, *MYSIDOPSIS BAHIA*, TOXICITY TEST^{1,2,3}

Compound	Concentration (g/L)	Amount (g) Required for 20L
NaCl	21.03	420.6
Na ₂ SO ₄	3.52	70.4
KCl	0.61	12.2
KBr	0.088	1.76
Na ₂ B ₄ O ₇ · 10 H ₂ O	0.034	0.68
MgCl ₂ · 6 H ₂ O	9.50	190.0
CaCl ₂ · 2 H ₂ O	1.32	26.4
SrCl ₂ · 6 H ₂ O	0.02	0.400
NaHCO ₃	0.17	3.40

¹ Modified GP2 from Spotte et al. (1984).

² The constituent salts and concentrations were taken from USEPA (1990b). The salinity is 30.89 g/L.

³ GP2 can be diluted with deionized (DI) water to the desired test salinity.

before use as the testing medium. If the solution is to be autoclaved, sodium bicarbonate is added after the solution has cooled. A stock solution of sodium bicarbonate is made up by dissolving 33.6 g NaHCO₃ in 500 mL of deionized water. Add 2.5 mL of this stock solution for each liter of the GP2 artificial seawater.

14.6.12 BRINE SHRIMP, *ARTEMIA*, NAUPLII -- for feeding cultures and test organisms.

14.6.12.1 Newly hatched *Artemia* nauplii are used for food for the stock cultures and test organisms. Although there are many commercial sources of brine shrimp cysts, the Brazilian or Colombian strains are preferred because the supplies examined have had low concentrations of chemical residues and

TABLE 2. QUANTITIES OF EFFLUENT, DEIONIZED WATER, AND HYPERSALINE BRINE (100‰) NEEDED TO PREPARE 1800 ML VOLUMES OF TEST SOLUTION WITH A SALINITY OF 20‰

Effluent Concentration (%)	Volume of Effluent (0‰) (mL)	Volume of Deionized Water (mL)	Volume of Hypersaline Brine (mL)	Total Volume (mL)
80	1440	0	360	1800
40	720	720	360	1800
20	360	1080	360	1800
10	180	1260	360	1800
5	90	1350	360	1800
Control	0	1440	360	1800
Total	2790	5850	2160	10800

produce nauplii of suitably small size. For commercial sources of brine shrimp, *Artemia*, cysts, see Table 2 of Section 5, Facilities, Equipment, and Supplies); and Section 4, Quality Assurance.

14.6.12.2 Each new batch of *Artemia* cysts must be evaluated for size (Vanhaecke and Sorgeloos, 1980, and Vanhaecke et al., 1980) and nutritional suitability (Leger, et al., 1985, Leger, et al., 1986) against known suitable reference cysts by performing a side-by-side larval growth test using the "new" and "reference" cysts. The "reference" cysts used in the suitability test may be a previously tested and acceptable batch of cysts, or may be obtained from the Quality Assurance Research Division, EMSL, Cincinnati, OH 45268, 513-569-7325. A sample of newly-hatched *Artemia* nauplii from each new batch of cysts should be chemically analyzed. The *Artemia* cysts should not be used if the concentration of total organic chlorine exceeds 0.15 µg/g wet

weight or the total concentration of organochlorine pesticides plus PCBs exceeds 0.30 $\mu\text{g/g}$ wet weight (For analytical methods see USEPA, 1982).

14.6.12.2.1 *Artemia* nauplii are obtained as follows:

1. Add 1 L of seawater, or an aqueous uniodized salt (NaCl) solution prepared with 35 g salt or artificial sea salts to 1 L of deionized water, to a 2-L separatory funnel, or equivalent.
2. Add 10 mL *Artemia* cysts to the separatory funnel and aerate for 24 h at 27°C. Hatching time varies with incubation temperature and the geographic strain of *Artemia* used (see USEPA, 1985a; USEPA, 1993a; ASTM, 1993).
3. After 24 h, cut off the air supply in the separatory funnel. *Artemia* nauplii are phototactic, and will concentrate at the bottom of the funnel if it is covered for 5-10 minutes. To prevent mortality, do not leave the concentrated nauplii at the bottom of the funnel more than 10 min without aeration.
4. Drain the nauplii into a beaker or funnel fitted with a $\leq 150 \mu\text{m}$ NITEX® or stainless steel screen, and rinse with seawater or equivalent before use.

14.6.12.3 Testing *Artemia* nauplii as food for toxicity test organisms.

14.6.12.3.1 The primary criteria for acceptability of each new supply of brine shrimp, cysts is adequate survival, growth, and reproduction of the mysids. The mysids used to evaluate the acceptability of the brine shrimp nauplii must be of the same geographical origin and stage of development (7 days old) as those used routinely in the toxicity tests. Sufficient data to detect differences in survival and growth should be obtained by using eight replicate test chambers, each containing 5 mysids, for each type of food.

14.6.12.3.2 The feeding rate and frequency, test vessels, volume of control water, duration of the test, and age of the *Artemia* nauplii at the start of the test, should be the same as used for the routine toxicity tests.

14.6.12.3.3 Results of the brine shrimp, *Artemia*, nauplii nutrition assay, where there are only two treatments, can be evaluated statistically by use of a t test. The "new" food is acceptable if there are no statistically significant differences in the survival, growth, and reproduction of the mysids fed the two sources of nauplii.

14.6.13 TEST ORGANISMS, *Mysidopsis bahia* (see Rodgers et al., 1986 and USEPA, 1993a for information on mysid ecology).

14.6.13.1 Brood Stock

14.6.13.1.1 To provide an adequate supply of juveniles for a test, mysid, *Mysidopsis bahia*, cultures should be started at least four weeks before the test animals are needed. At least 200 mysids, *Mysidopsis bahia*, should be placed in each culture tank to ensure that 1500 to 2000 animals will be available by the time preparations for a test are initiated.

14.6.13.1.2 Mysids, *Mysidopsis bahia*, may be shipped or otherwise transported in polyethylene bottles or CUBITAINERS®. Place 50 animals in 700 mL of seawater in a 1-L shipping container. To control bacterial growth and prevent DO depletion during shipment, do not add food. Before closing the shipping container, oxygenate the water for 10 min. The mysids, *Mysidopsis bahia*, will starve if not fed within 36 h, therefore, they should be shipped so that they are not in transit more than 24 h.

14.6.13.1.3 The identification of the *Mysidopsis bahia* stock culture should be verified using the key from Heard (1982), Price (1978), Price, (1982), Stuck et al. (1979a), and Stuck et al. (1979b). Records of the verification should be retained along with a few of the preserved specimens.

14.6.13.1.4 Glass aquaria (120- to 200-L) are recommended for cultures. Other types of culture chambers may also be convenient. Three or more separate cultures should be maintained to protect against loss of the entire culture stock in case of accident, low DO, or high nitrite levels, and to provide sufficient numbers of juvenile mysids, *Mysidopsis bahia*, for toxicity tests. Fill the aquaria about three-fourths full of seawater. A flow-through system is recommended if sufficient natural seawater is available, but a closed, recirculating or static renewal system may be used if proper water conditioning is provided and care is exercised to keep the pH above 7.8 and nitrite levels below 0.05 mg/L.

14.6.13.1.5 Standard aquarium undergravel filters should be used with either the flow-through or recirculating system to provide aeration and a current conducive to feeding (Gentile et al., 1983). The undergravel filter is covered with a prewashed, coarse (2-5 mm) dolomite substrate, 2.5 cm deep for flow-through cultures or 10 cm deep for recirculating cultures.

14.6.13.1.6 The recirculating culture system is conditioned as follows:

1. After the dolomite has been added, the filter is attached to the air supply and operated for 24 h.
2. Approximately 4 L of seed water obtained from a successfully operating culture is added to the culture chamber.
3. The nitrite level is checked daily with an aquarium test kit or with EPA Method 354.1 (USEPA, 1979b).
4. Add about 30 mL of concentrated *Artemia* nauplii every other day until the nitrite level reaches at least 2.0 mg/L. The nitrite will continue to rise for several days without adding more *Artemia* nauplii and will then slowly decrease to less than 0.05 mg/L.
5. After the nitrite level falls below 0.05 mg/L, add another 30 mL of *Artemia* nauplii concentrate and check the nitrite concentration every day.
6. Continue this cycle until the addition of *Artemia* nauplii does not cause a rise in the nitrite concentration. The culture chamber is then conditioned and is ready to receive mysids.
7. Add only a few (5-20) mysids at first, to determine if conditions are favorable. If these mysids are still doing well after a week, several hundred more can be added.

14.6.13.1.7 It is important to add enough food to keep the adult animals from cannibalizing the young, but not so much that the DO is depleted or that there is a buildup of toxic concentrations of ammonia and nitrite. Just enough newly-hatched *Artemia nauplii* are fed twice a day so that each feeding is consumed before the next feeding.

14.6.13.1.8 Natural seawater is recommended as the culture medium, but HSB may be used to make up the culture water if natural seawater is not available. EMSL-Cincinnati has successfully used FORTY FATHOMS® artificial sea salts for culturing and toxicity tests of mysids, and USEPA, Region 6 has used HW MARINEMIX® artificial sea salts.

14.6.13.1.9 Mysids, *Mysidopsis bahia*, should be cultured at a temperature of $26 \pm 1^\circ\text{C}$. No water temperature control equipment is needed if the ambient laboratory temperature remains in the recommended range, and if there are no frequent, rapid, large temperature excursions in the culture room.

14.6.13.1.10 The salinity should be maintained at $30 \pm 2\text{‰}$, or at a lower salinity (but not less than 20‰) if most of the tests will be conducted at a lower salinity.

14.6.13.1.11 Day/night cycles prevailing in most laboratories will provide adequate illumination for normal growth and reproduction. A 16-h/8-h day/night cycle in which the light is gradually increased and decreased to simulate dawn and dusk conditions, is recommended.

14.6.13.1.12 Mysid, *Mysidopsis bahia*, culture may suffer if DOs fall below 5 mg/L for extended periods. The undergravel filter will usually provide sufficient DO. If the DO drops below 5 mg/L at 25°C and 30‰ , additional aeration should be provided. Measure the DO in the cultures daily the first week and then at least weekly thereafter.

14.6.13.1.13 Suspend a clear glass or plastic panel over the cultures, or use some other means of excluding dust and dirt, but leave enough space between the covers and culture tanks to allow circulation of air over the cultures.

14.6.13.1.14 If hydroids or worms appear in the cultures, remove the mysids and clean the chambers thoroughly, using soap and hot water. Rinse once with acid (10% HCl) and three times with distilled or deionized water. Mysids with attached hydroids should be discarded. Those without hydroids should be transferred by hand pipetting into three changes of clean seawater before returning them to the cleaned culture chamber. To guard against predators, natural seawater should be filtered through a net with $30 \mu\text{m}$ mesh openings before entering the culture vessels.

14.6.13.1.15 Mysids, *Mysidopsis bahia*, are very sensitive to low pH and sudden changes in temperature. Care should be taken to maintain the pH at 8.0 ± 0.3 , and to limit rapid changes in water temperature to less than 3°C .

14.6.13.1.16 Mysids, *Mysidopsis bahia*, should be handled carefully and as little as possible so that they are not unnecessarily stressed or injured. They should be transferred between culture chambers with long handled cups

with netted bottoms. Animals should be transferred to the test vessels with a large bore pipette (4-mm), taking care to release the animals under the surface of the water. Discard any mysids that are injured during handling.

14.6.13.1.17 Culture Maintenance (Also See USEPA, 1993a)

14.6.13.1.17.1 Cultures in closed, recirculating systems are fed twice a day. If no nauplii are present in the culture chamber after four hours, the amount of food should be increased slightly. In flow-through systems, excess food can be a problem by promoting bacterial growth and low dissolved oxygen.

14.6.13.1.17.2 Careful culture maintenance is essential. The organisms should not be allowed to become too crowded. The cultures should be cropped as often as necessary to maintain a density of about 20 mysids per liter. At this density, at least 70% of the females should have eggs in their brood pouch. If they do not, the cultures are probably under stress, and the cause should be found and corrected. If the cause cannot be found, it may be necessary to restart the cultures with a clean culture chamber, a new batch of culture water, and clean gravel.

14.6.13.1.17.3 In closed, recirculating systems, about one third of the culture water should be replaced with newly prepared seawater every week. Before siphoning the old media from the culture, it is recommended that the sides of the vessel be scraped and the gravel carefully turned over to prevent excessive buildup of algal growth. Twice a year the mysids should be removed from the recirculating cultures, the gravel rinsed in clean seawater, the sides of the chamber washed with clean seawater, and the gravel and animals returned to the culture vessel with newly conditioned seawater. No detergent should be used, and care should be taken not to rinse all the bacteria from the gravel.

14.6.13.2 Test Organisms

14.6.13.2.1 The test is begun with 7-day-old juveniles. To have the test animals available and acclimated to test conditions at the start of the test, they must be obtained from the stock culture eight days in advance of the test. Whenever possible, brood stock should be obtained from cultures having similar salinity, temperature, light regime, etc., as are to be used in the toxicity test.

14.6.13.2.2 Eight days before the test is to start, sufficient gravid females are placed in brood chambers. Assuming that 240 juveniles are needed for each test, approximately half this number (120) of gravid females should be transferred to brood chambers. The mysids are removed from the culture tank with a net or netted cup and placed in 20-cm diameter finger bowls. The gravid females are transferred from the finger bowls to the brood chambers with a large-bore pipette or, alternatively, are transferred by pouring the contents of the finger bowls into the water in the brood chambers.

14.6.13.2.3 The mysid juveniles may be collected for the toxicity tests by transferring gravid females from the stock cultures to netted (1000 μm) flow-through containers (Figure 1) held within 4-L glass, wide-mouth

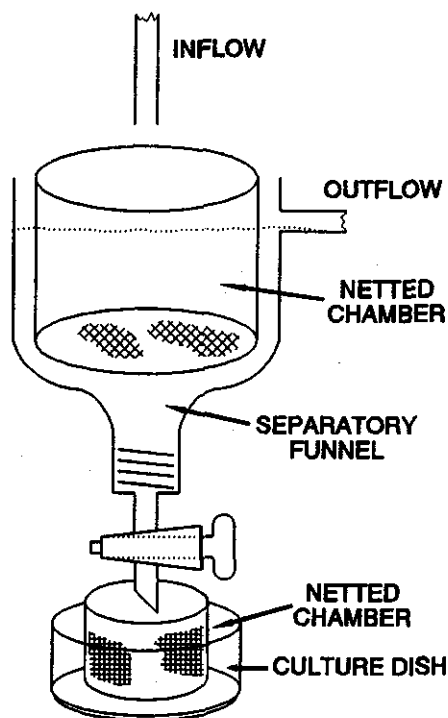

Figure 1. Apparatus (brood chamber) for collection of juvenile mysids, *Mysidopsis bahia*. From USEPA (1987d).

separatory funnels. Newly released juveniles can pass through the netting, whereas the females are retained. The gravid females are fed newly hatched *Artemia* nauplii, and are held overnight to permit the release of young. The juvenile mysids are collected by opening the stopcock on the funnel and collecting them in another container from which they are transferred to holding tanks using a wide bore (4 mm ID) pipette. The brood chambers usually require aeration to maintain sufficient DO and to keep the food in suspension.

14.6.13.2.4 The temperature in the brood chamber should be maintained at the upper acceptable culture limit (26 - 27°C), or 1°C higher than the cultures, to encourage faster brood release. At this temperature, sufficient juveniles should be produced for the test.

14.6.13.2.5 The newly released juveniles (age = 0 days) are transferred to 20-L glass aquaria (holding vessels) which are gently aerated. Smaller holding vessels may be used, but the density of organisms should not exceed 10 mysids per liter. The test animals are held in the holding vessel for six days prior to initiation of the test. The holding medium is renewed every other day.

14.6.13.2.6 During the holding period, the mysids are acclimated to the salinity at which the test will be conducted, unless already at that salinity. The salinity should be changed no more than 2‰ per 24 h to minimize stress on the juveniles.

14.6.13.2.7 The temperature during the holding period is critical to mysid development, and must be maintained at $26 \pm 1^\circ\text{C}$. If the temperature cannot be maintained in this range, it is advisable to hold the juveniles an additional day before beginning the test.

14.6.13.2.8 During the holding period, just enough newly-hatched *Artemia* nauplii are fed twice a day (a total of at least 150 nauplii per mysid per day) so that some food is constantly present.

14.6.13.2.9 If the test is to be performed in the field, the juvenile mysids, *Mysidopsis bahia*, should be gently siphoned into 1-L polyethylene wide-mouth jars with screw-cap lids filled two-thirds full with clean seawater from the holding tank. The water in these jars is aerated for 10 min, and the jars are capped and packed in insulated boxes for shipment to the test site. Food should not be added to the jars to prevent the development of excessive bacterial growth and a reduction in DO.

14.6.13.2.10 Upon arrival at the test site (in less than 24 h) the mysids, *Mysidopsis bahia*, are gently poured from the jars into 20-cm diameter glass culture dishes. The jars are rinsed with salt water to dislodge any mysids that may adhere to the sides. If the water appears milky, siphon off half of it with a netted funnel (to avoid siphoning the mysids) and replace with clean salt water of the same salinity and temperature. If no *Artemia* nauplii are present in the dishes, feed about 150 *Artemia* nauplii per mysid.

14.7 EFFLUENT AND RECEIVING WATER COLLECTION, PRESERVATION, AND STORAGE

14.7.1 See Section 8, Effluent and Receiving Water Sampling, Sample Handling, and Sample Preparation for Toxicity Tests.

14.8 CALIBRATION AND STANDARDIZATION

14.8.1 See Section 4, Quality Assurance.

14.9 QUALITY CONTROL

14.9.1 See Section 4, Quality Assurance.

14.9.2 The reference toxicant recommended for use with the mysid 7-day test is copper sulfate or sodium dodecyl sulfate.

14.10 TEST PROCEDURES

14.10.1 TEST DESIGN

14.10.1.1 The test consists of at least five effluent concentrations plus a site water control and a reference water treatment (natural seawater or seawater made up from hypersaline brine, or equivalent).

14.10.1.2 Effluent concentrations are expressed as percent effluent.

14.10.1.3 Eight replicate test vessels, each containing 5 to 7 day old animals, are used per effluent concentration and control.

14.10.2 TEST SOLUTIONS

14.10.2.1 Receiving waters

14.10.2.1.1 The sampling point(s) is determined by the objectives of the test. At estuarine and marine sites, samples are usually collected at mid-depth. Receiving water toxicity is determined with samples used directly as collected or with samples passed through a 60 μm NITEX® filter and compared without dilution, against a control. Using eight replicate chambers per test, each containing 150 mL, and 400 mL for chemical analysis, would require approximately 1.6 L or more of sample per test per day.

14.10.2.2 Effluents

14.10.2.2.1 The selection of the effluent test concentrations should be based on the objectives of the study. A dilution factor of 0.5 is commonly used. A dilution factor of 0.5 provides precision of $\pm 100\%$, and testing of concentrations between 6.25% and 100% effluent using only five effluent concentrations (6.25%, 12.5%, 25%, 50%, and 100%). Test precision shows little improvement as dilution factors are increased beyond 0.5 and declines rapidly if smaller dilution factors are used. Therefore, USEPA recommends the use of the ≥ 0.5 dilution factor. If 100‰ HSB is used as a diluent, the maximum concentration of effluent that can be tested will be 80% at 20‰ and 70% at 30‰ salinity.

14.10.2.2.2 If the effluent is known or suspected to be highly toxic, a lower range of effluent concentrations should be used (such as 25%, 12.5%, 6.25%, 3.12%, and 1.56%). If high mortality is observed during the first 1-to-2 h of the test, additional dilutions at the lower range of effluent concentrations should be added.

14.10.2.2.3 The volume of effluent required for daily renewal of eight replicates per concentration for five concentrations of effluent and a control, each containing 150 mL of test solution, is approximately 1200 mL. Prepare enough test solution (approximately 1600 mL) at each effluent concentration to provide 400 mL additional volume for chemical analyses.

14.10.2.2.4 Just prior to test initiation (approximately 1 h), the temperature of a sufficient quantity of the sample to make the test solutions should be adjusted to the test temperature ($26 \pm 1^\circ\text{C}$) and maintained at that temperature during the addition of dilution water.

14.10.2.2.5 Higher effluent concentrations (i.e., 25%, 50%, and 100%) may require aeration to maintain adequate dissolved oxygen concentrations. However, if one solution is aerated, all concentrations must be aerated. Aerate effluent as it warms and continue to gently aerate test solutions in the test chambers for the duration of the test.

14.10.2.2.6 Effluent dilutions should be prepared for all replicates in each treatment in one flask to minimize variability among the replicates. The test chambers (cups) are labelled with the test concentration and replicate number. Dispense 150 mL of the appropriate effluent dilution to each test chamber.

14.10.2.3 Dilution Water

14.10.2.3.1 Dilution water may be uncontaminated natural seawater (receiving water), HSB prepared from natural seawater, or artificial seawater prepared from FORTY FATHOMS® or GP2 sea salts (see Table 1 and Section 7, Dilution Water). Other artificial sea salts may be used for culturing mysid and for the survival, growth, and fecundity test if the control criteria for acceptability of test data are satisfied.

14.10.3 START OF THE TEST

14.10.3.1 The test should begin as soon as possible, preferably within 24 h after sample collection. The maximum holding time following retrieval of the sample from the sampling device should not exceed 36 h for off-site toxicity tests unless permission is granted by the permitting authority. In no case should the test be started more than 72 h after sample collection (see Section 8, Effluent and Receiving Water Sampling, Sample Handling, and Sample Preparation for Toxicity Tests).

14.10.3.2 Begin the test by randomly placing five animals (one at a time) in each test cup of each treatment using a large bore (4 mm ID) pipette (see Appendix A for an example of randomization). It is easier to capture the animals if the volume of water in the dish is reduced and the dish is placed on a light table. It is recommended that the transfer pipette be rinsed frequently because mysids tend to adhere to the inside surface.

14.10.4 LIGHT, PHOTOPERIOD, SALINITY AND TEMPERATURE

14.10.4.1 The light quality and intensity under ambient laboratory conditions are generally adequate. Light intensity of 10-20 $\mu\text{E}/\text{m}^2/\text{s}$, or 50 to 100 foot candles (ft-c), with a photoperiod of 16 h light and 8 h darkness. It is critical that the test water temperature be maintained at $26 \pm 1^\circ\text{C}$. It is recommended that the test water temperature be continuously recorded. The salinity should vary no more than $\pm 2\%$ among chambers on a given day. If effluent and receiving water tests are conducted concurrently, the salinities of these tests should be similar.

14.10.4.1.1 If a water bath is used to maintain the test temperature, the water depth surrounding the test cups should be at least 2.5 cm deep.

14.10.4.1.2 Rooms or incubators with high volume ventilation should be used with caution because the volatilization of the test solutions and evaporation of dilution water may cause wide fluctuations in salinity. Covering the test cups with clear polyethylene plastic may help prevent volatilization and evaporation of the test solutions.

14.10.5 DISSOLVED OXYGEN (DO) CONCENTRATION

14.10.5.1 Aeration may affect the toxicity of effluents and should be used only as a last resort to maintain a satisfactory DO. The DO should be measured on new solutions at the start of the test (Day 0) and before daily renewal of test solutions on subsequent days. The DO should not fall below 4.0 mg/L (see Section 8, Effluent and Receiving Water Sampling, Sample Handling, and Sample Preparation for Toxicity Tests). If it is necessary to aerate, all treatments and the control should be aerated. The aeration rate should not exceed 100 bubbles/minute, using a pipet with a 1-2 mm orifice, such as a 1-mL KIMAX® serological pipet No. 37033, or equivalent. Care should be taken to ensure that turbulence resulting from aeration does not cause undue stress on the mysid.

14.10.6 FEEDING

14.10.6.1 *Artemia* nauplii are prepared as described above.

14.10.6.2 During the test, the mysids in each test chamber should be fed *Artemia* nauplii, (less than 24-h old), at the rate of 150 nauplii per mysid per day. Adding the entire daily ration at a single feeding immediately after test solution renewal may result in a significant DO depression. Therefore, it is preferable to feed half of the daily ration immediately after test solution renewal, and the second half 8 - 12 h later. Increase the feeding if the nauplii are consumed in less than 4 h. It is important that the nauplii be washed before introduction to the test chamber.

14.10.7 DAILY CLEANING OF TEST CHAMBERS

14.10.7.1 Before the daily renewal of test solutions, uneaten and dead *Artemia*, dead mysids and other debris are removed from the bottom of the test chambers with a pipette. As much of the uneaten *Artemia* as possible should be removed from each chamber to ensure that the mysids principally eat new hatched nauplii. By placing the test chambers on a light box, inadvertent removal of live mysids can be greatly reduced because they can be more easily seen. Any incidence of removal of live mysids from the test chambers during cleaning, and subsequent return to the chambers should be noted in the test records.

14.10.8 OBSERVATIONS DURING THE TEST

14.10.8.1 Routine Chemical and Physical Determinations

14.10.8.1.1 DO is measured at the beginning and end of each 24-h exposure period in one test chamber at each test concentration and in the control.

14.10.8.1.2 Temperature, pH, and salinity are measured at the end of each 24-h exposure period in one test chamber at each concentration and in the control. Temperature should also be monitored continuously observed and recorded daily for at least two locations in the environmental control system or the samples. Temperature should be measured in a sufficient number of test

chambers at least at the end of the test to determine temperature variation in environmental chamber.

14.10.8.1.3 The pH is measured in the effluent sample each day before new test solutions are made.

14.10.8.2 Routine Biological Observations

14.10.8.2.1 The number of live mysids are counted and recorded each day when the test solutions are renewed (Figure 2). Dead animals and excess food should be removed with a pipette before test solutions are renewed.

14.10.8.2.2 Protect the mysids from unnecessary disturbance during the test by carrying out the daily test observations, solution renewals, and removal of the dead mysids, carefully. Make sure the mysids remain immersed during the performance of the above operations.

14.10.9 TEST SOLUTION RENEWAL

14.10.9.1 Before the daily renewal of test solutions, slowly pour off all but 10 mL of the old test medium into a 20 cm diameter culture dish on a light table. Be sure to check for animals that may have adhered to the sides of the test chamber. Rinse them back into the test cups. Add 150 mL of new test solution slowly to each cup. Check the culture dish for animals that may have been poured out with the old media, and return them to the test chamber.

14.10.10 TERMINATION OF THE TEST

14.10.10.1 After measuring the DO, pH, temperature, and salinity and recording survival, terminate the test by pouring off the test solution in all the cups to a one cm depth and refilling the cups with clean seawater. This will keep the animals alive, but not exposed to the toxicant, while waiting to be examined for sex and the presence of eggs.

14.10.10.2 The live animals must be examined for eggs and the sexes determined within 12 h of the termination of the test. If the test was conducted in the field, and the animals cannot be examined on site, the live animals should be shipped back to the laboratory for processing. Pour each replicate into a labelled 100 mL plastic screw capped jar, and send to the laboratory immediately.

14.10.10.3 If the test was conducted in the laboratory, or when the test animals arrive in the laboratory from the field test site, the test organisms must be processed immediately while still alive as follows:

14.10.10.3.1 Examine each replicate under a stereomicroscope (240X) to determine the number of immature animals, the sex of the mature animals, and the presence or absence of eggs in the oviducts or brood sacs of the females (see Figures 3-6). This must be done while the mysids are alive because they turn opaque upon dying. This step should not be attempted by a person who has not had specialized training in the determination of sex and presence of eggs

TEST: _____

START DATE: _____

SALINITY: _____

	TRTMT	TEMP	SALINITY	D.O.	pH	TRTMT	TEMP	SALINITY	D.O.	pH	
DAY 1	REP										
	REP										
DAY 2	REP										
	REP										
DAY 3	REP										
	REP										
DAY 4	REP										
	REP										
DAY 5	REP										
	REP										
DAY 6	REP										
	REP										
DAY 7	REP										
	REP										
	TRTMT	TEMP	SALINITY	D.O.	pH	TRTMT	TEMP	SALINITY	D.O.	pH	
DAY 1	REP										
	REP										
DAY 2	REP										
	REP										
DAY 3	REP										
	REP										
DAY 4	REP										
	REP										
DAY 5	REP										
	REP										
DAY 6	REP										
	REP										
DAY 7	REP										
	REP										

Figure 2. Data form for the mysid, *Mysidopsis bahia*, water quality measurements. From USEPA (1987d).

MATURE FEMALE, EGGS IN OVIDUCTS

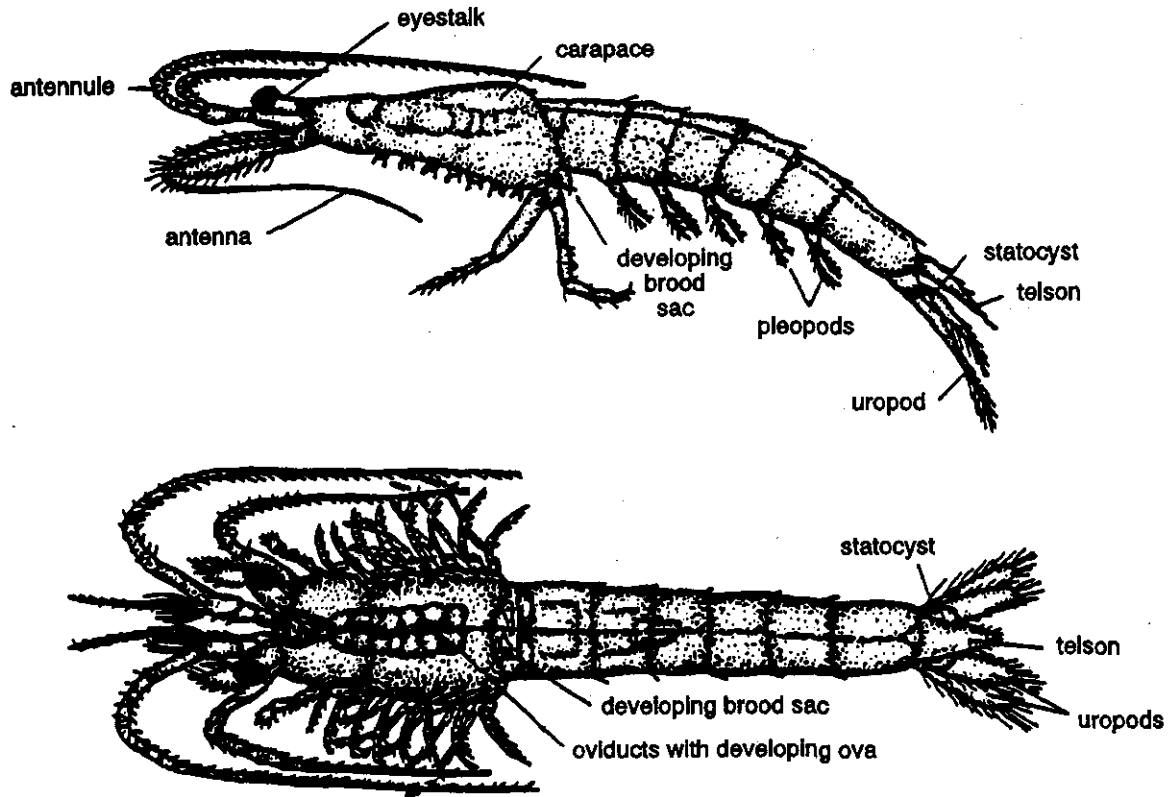

Figure 3. Mature female, mysid, *Mysidopsis bahia*, with eggs in oviducts. From USEPA (1987d).

in the oviduct. NOTE: Adult females without eggs in the oviduct or brood sac look like immature mysids (see Figure 6).

14.10.10.3.2 Record the number of immatures, males, females with eggs and females without eggs on data sheets (Figure 7).

14.10.10.3.3 Rinse the mysids by pipetting them into a small netted cup and dipping the cup into a dish containing deionized water. Using forceps, place the mysids from each replicate cup on tared weighing boats and dry at 60°C for 24 h or at 105°C for at least 6 h.

14.10.10.3.4 Immediately upon removal from the drying oven, the weighing pans were placed in a dessicator until weighed, to prevent absorption of moisture from the air. Weigh to the nearest mg. Record weighing pans and subtract the

MATURE FEMALE, EGGS IN BROOD SAC

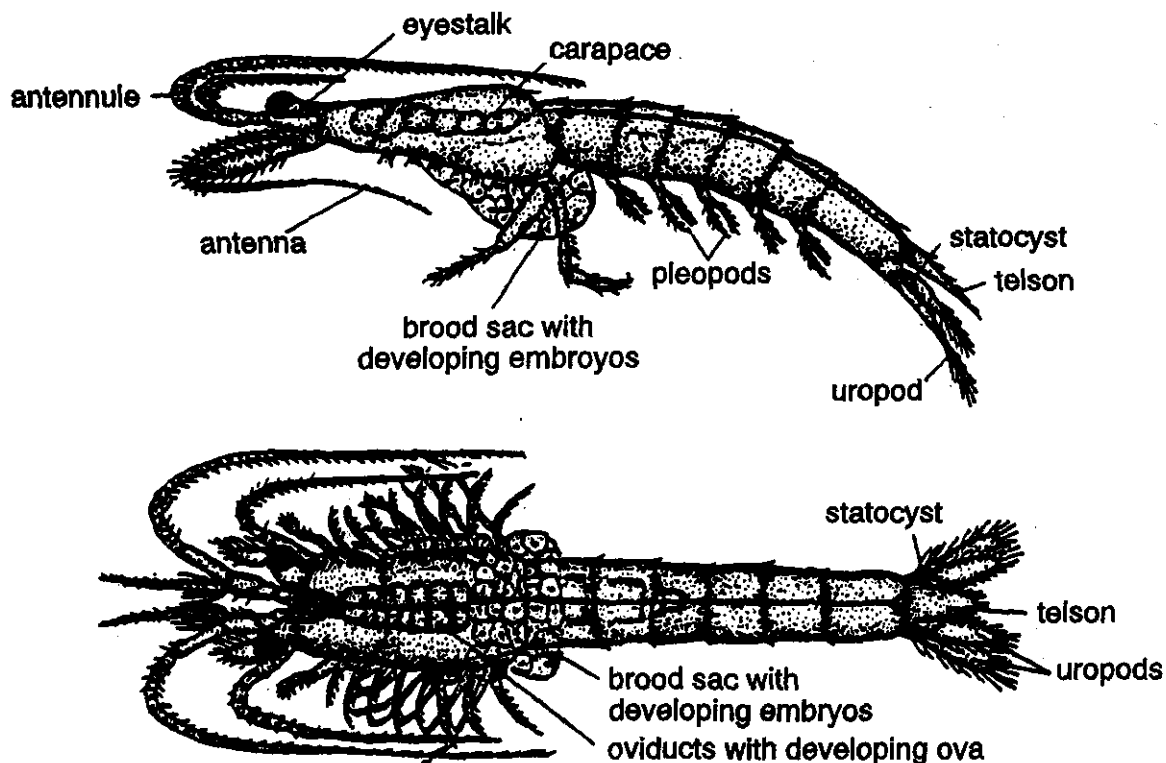

Figure 4. Mature female mysid, *Mysidopsis bahia*, with eggs in oviducts and developing embryos in the brood sac. Above: lateral view. Below: dorsal view. From USEPA (1987d).

tare weight to determine the dry weight of the mysid in each replicate. Record the weights (Figure 8). For each test chamber, divide the first dry weight by the number of original mysids per replicate to determine the average individual dry weight and record data. For the controls also calculate the mean weight per surviving mysid in the test chamber to evaluate if weights met test acceptability criteria (see Subsection 14.2).

14.10.9.3.5 Pieces of aluminum foil (1-cm square) or small aluminum weighing pans can be used for dry weight analyses. The weighing pans should not exceed 10 mg in weight.

14.10.9.3.6 Number each pan with a waterproof pen with the treatment concentration and replicate number. Forty-eight (48) weigh pans are required per test if all the organisms survive.

MATURE MALE

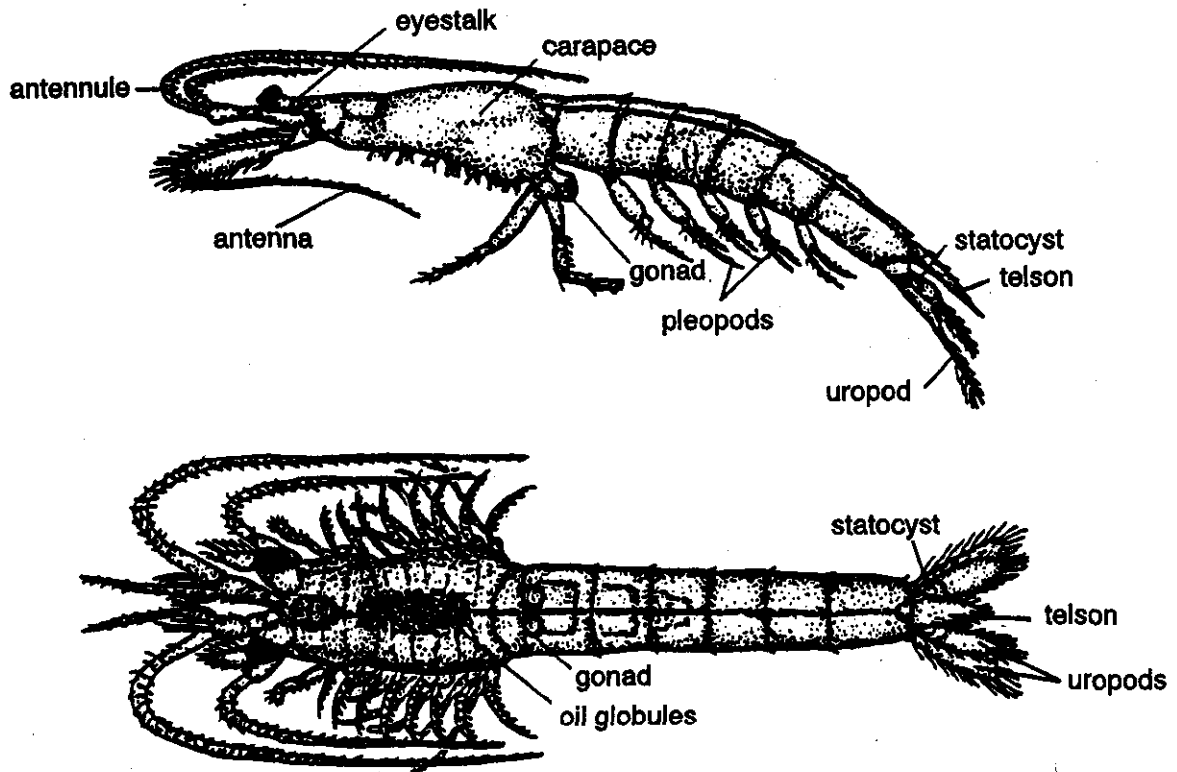

Figure 5. Mature male mysid, *Mysidopsis bahia*. From USEPA (1987d).

14.11 SUMMARY OF TEST CONDITIONS AND TEST ACCEPTABILITY CRITERIA

14.11.1 A summary of test conditions and test acceptability criteria is listed in Table 3.

14.12 ACCEPTABILITY OF TEST RESULTS

14.12.1 The minimum requirements for an acceptable test are 80% survival and an average weight of at least 0.20 mg/mysid in the controls. If fecundity in the controls is adequate (egg production by 50% of females), fecundity should be used as a criterion of effect in addition to survival and growth.

14.13 DATA ANALYSIS

14.13.1 GENERAL

14.13.1.1 Tabulate and summarize the data. Table 4 presents a sample set of survival, growth, and fecundity data.

IMMATURE

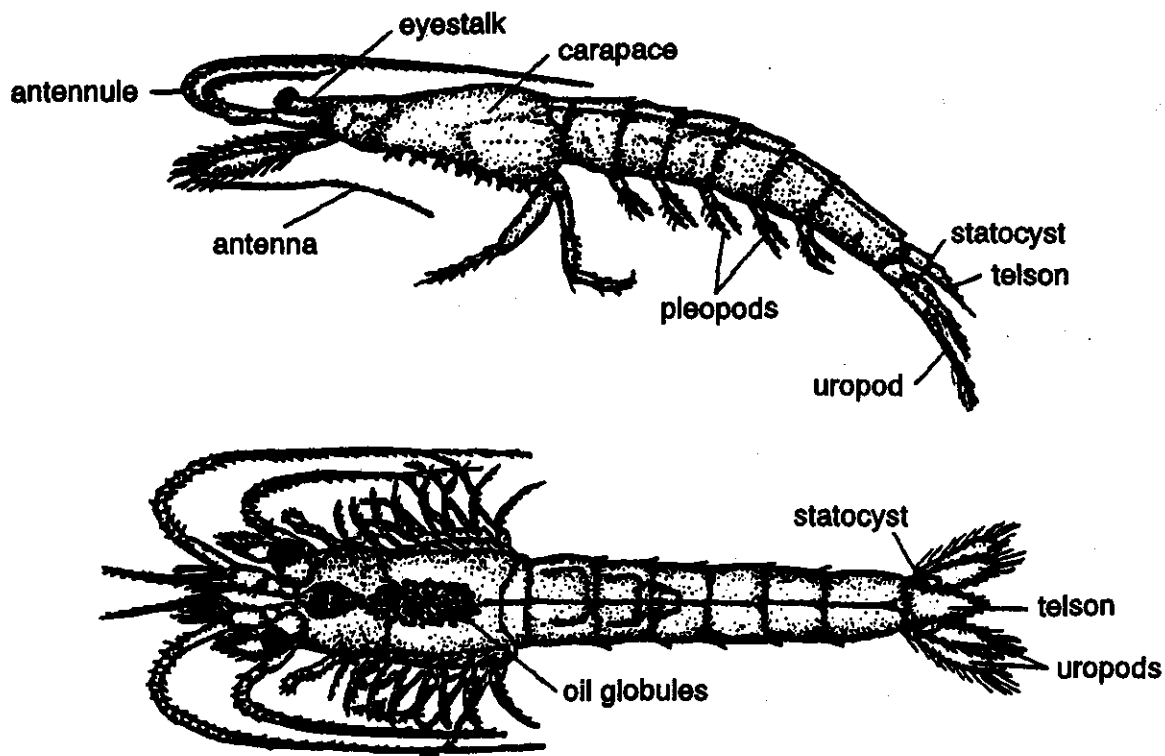

Figure 6. Immature mysid, *Mysidopsis bahia*, (A) lateral view, (B) dorsal view. From USEPA (1987d).

14.13.1.2 The endpoints of the mysid 7-day chronic test are based on the adverse effects on survival, growth, and egg development. The LC50, the IC25, and the IC50 are calculated using point estimation techniques (see Section 9, Chronic Toxicity Test Endpoints and Data Analysis). LOEC and NOEC values for survival, growth, and fecundity are obtained using a hypothesis testing approach such as Dunnett's Procedure (Dunnett, 1955) or Steel's Many-one Rank Test (Steel, 1959; Miller, 1981) (see Section 9). Separate analyses are performed for the estimation of the LOEC and NOEC endpoints and for the estimation of the LC50, IC25, and IC50. Concentrations at which there is no survival in any of the test chambers are excluded from the statistical analysis of the NOEC and LOEC for survival, growth, and fecundity, but included in the estimation of the LC50, IC25, and IC50. See the Appendices for examples of the manual computations, and examples of data input and program output.

14.13.1.3 The statistical tests described here must be used with a knowledge of the assumptions upon which the tests are contingent. The assistance of a statistician is recommended for analysts who are not proficient in statistics.

TEST: _____

START DATE: _____

SALINITY: _____

TREATMENT/ REPLICATE	DAY 1 # ALIVE	DAY 2 # ALIVE	DAY 3 # ALIVE	DAY 4 # ALIVE	DAY 5 # ALIVE	DAY 6 # ALIVE	DAY 7 # ALIVE	FEMALES W/EGGS	FEMALES NO EGGS	MALES	IMMATURES
C	1										
	2										
	3										
	4										
	5										
	6										
	7										
	8										
1	1										
	2										
	3										
	4										
	5										
	6										
	7										
	8										
2	1										
	2										
	3										
	4										
	5										
	6										
	7										
	8										

Figure 7. Data form for the mysid, *Mysidopsis bahia*, survival and fecundity data. From USEPA (1987d).

TEST: _____

START DATE: _____

SALINITY: _____

TREATMENT/ REPLICATE	DAY 1 # ALIVE	DAY 2 # ALIVE	DAY 3 # ALIVE	DAY 4 # ALIVE	DAY 5 # ALIVE	DAY 6 # ALIVE	DAY 7 # ALIVE	FEMALES W/EGGS	FEMALES NO EGGS	MALES	IMMATURES
3	1										
	2										
	3										
	4										
	5										
	6										
	7										
	8										
4	1										
	2										
	3										
	4										
	5										
	6										
	7										
	8										
5	1										
	2										
	3										
	4										
	5										
	6										
	7										
	8										

Figure 7. Data form for the mysid, *Mysidopsis bahia*, survival and fecundity data (CONTINUED). From USEPA (1987d).

TEST: _____

START DATE: _____

SALINITY: _____

TREATMENT/ REPLICATE	PAN #	TARE WT.	TOTAL WT.	ANIMAL WT.	# OF ANIMALS	\bar{X} WT./ ANIMAL
C	1					
	2					
	3					
	4					
	5					
	6					
	7					
	8					
1	1					
	2					
	3					
	4					
	5					
	6					
	7					
	8					
2	1					
	2					
	3					
	4					
	5					
	6					
	7					
	8					

Figure 8. Data form for the mysid, *Mysidopsis bahia*, dry weight measurements. From USEPA (1987d).

TEST: _____

START DATE: _____

SALINITY: _____

TREATMENT/ REPLICATE	PAN #	TARE WT.	TOTAL WT.	ANIMAL WT.	# OF ANIMALS	\bar{X} WT./ ANIMAL
3	1					
	2					
	3					
	4					
	5					
	6					
	7					
	8					
4	1					
	2					
	3					
	4					
	5					
	6					
	7					
	8					
5	1					
	2					
	3					
	4					
	5					
	6					
	7					
	8					

Figure 8. Data form for the mysid, *Mysidopsis bahia*, dry weight measurements (CONTINUED). From USEPA (1987d).

TABLE 3. SUMMARY OF TEST CONDITIONS AND TEST ACCEPTABILITY CRITERIA FOR THE MYSID, *MYSIDOPSIS BAHIA*, SEVEN DAY SURVIVAL, GROWTH, AND FECUNDITY TEST WITH EFFLUENTS AND RECEIVING WATERS

1. Test type:	Static renewal
2. Salinity:	20‰ to 30‰ (\pm 2‰ of the selected test salinity)
3. Temperature:	26 \pm 1°C
4. Light quality:	Ambient laboratory illumination
5. Light intensity:	10-20 μ E/m ² /s (50-100 ft-c.) (ambient laboratory levels)
6. Photoperiod:	16 h light, 8 h darkness, with phase in/out period
7. Test chamber:	8 oz plastic disposable cups, or 400 mL glass beakers
8. Test solution volume:	150 mL per replicate
9. Renewal of test solutions:	Daily
10. Age of test organisms:	7 days
11. No. organisms per test chamber:	5 (minimum)
12. No. replicate chambers per concentration:	8 (minimum)
13. No. larvae per concentration:	40 (minimum)
14. Source of food:	Newly hatched <i>Artemia</i> nauplii (less than 24 h old)
15. Feeding regime:	Feed 150 24 h old nauplii per mysid daily, half after test solution renewal and half after 8-12 h.
16. Cleaning:	Pipette excess food from cups daily immediately before test solution renewal and feeding.

TABLE 3. SUMMARY OF TEST CONDITIONS AND TEST ACCEPTABILITY CRITERIA FOR THE MYSID, *MYSIDOPSIS BAHIA*, SEVEN DAY SURVIVAL, GROWTH, AND FECUNDITY TEST WITH EFFLUENTS AND RECEIVING WATERS (CONTINUED)

17. Aeration:	None unless DO falls below 4.0 mg/L, then gently aerate in all cups
18. Dilution water:	Uncontaminated source of natural seawater, deionized water mixed with hypersaline brine or artificial sea salts (HW Marinemix [®] , FORTY FATHOMS [®] , GP2 or equivalent)
19. Test concentrations:	Effluents: Minimum of 5 and a control Receiving waters: 100% receiving water or minimum of 5 and a control
20. Dilution factor:	Effluents: ≥ 0.5 series Receiving waters: None, or ≥ 0.5
21. Test duration:	7 days
22. Endpoints:	Survival, growth, and egg development
23. Test acceptability criteria:	80% or greater survival, average dry weight 0.20 mg or greater in controls; fecundity may be used if 50% or more of females in controls produce eggs
24. Sampling requirements:	For on-site tests, samples collected daily, and used within 24 h of the time they are removed from the sampling device. For off-site tests, a minimum of three samples are collected on days one, three, and five with a maximum holding time of 36 h before first use (see Section 8, Effluent and Receiving Water Sampling, Sample Handling and Sample Preparation for Toxicity Tests, Subsection 8.5.4)
25. Sample volume required:	3 L per day

TABLE 4. DATA FOR *MYSIDOPSIS BAHIA* 7-DAY SURVIVAL, GROWTH, AND FECUNDITY TEST¹

Treatment	Replicate Chamber	Total Mysids	No. Alive	Total Females	Females w/Eggs	Mean Weight
Control	1	5	4	1	1	0.146
	2	5	4	2	2	0.118
	3	5	5	3	2	0.216
	4	5	5	1	1	0.199
	5	5	5	2	2	0.176
	6	5	5	5	4	0.243
	7	5	5	2	2	0.213
	8	5	4	3	3	0.144
50 ppb	1	5	4	2	1	0.154
	2	5	5	3	1	0.193
	3	5	4	3	2	0.190
	4	5	4	0	0	0.190
	5	5	5	5	2	0.256
	6	5	5	2	1	0.191
	7	5	4	4	1	0.122
	8	5	5	3	1	0.177
100 ppb	1	5	3	3	1	0.114
	2	5	5	2	1	0.172
	3	5	5	1	0	0.160
	4	5	5	2	1	0.199
	5	5	5	3	2	0.165
	6	5	3	1	0	0.145
	7	5	4	4	1	0.207
	8	4	4	0	0	0.186
210 ppb	1	5	5	1	0	0.153
	2	5	4	2	0	0.094
	3	5	1	1	0	0.017
	4	5	4	3	0	0.122
	5	5	3	1	0	0.052
	6	5	4	2	0	0.154
	7	5	4	1	0	0.110
	8	5	4	3	0	0.103
450 ppb	1	5	0	0	0	-
	2	5	1	0	0	0.012
	3	5	0	0	0	-
	4	5	1	0	0	0.002
	5	5	0	0	0	-
	6	5	0	0	0	-
	7	5	0	0	0	-
	8	5	2	1	0	0.081

¹ Data provided by Lussier, Kuhn and Sewall, Environmental Research Laboratory, U.S. Environmental Protection Agency, Narragansett, RI.

14.13.2 EXAMPLE OF ANALYSIS OF MYSID, *MYSIDOPSIS BAHIA*, SURVIVAL DATA

14.13.2.1 Formal statistical analysis of the survival data is outlined in Figures 9 and 10. The response used in the analysis is the proportion of animals surviving in each test or control chamber. Separate analyses are performed for the estimation of the NOEC and LOEC endpoints and for the estimation of the LC50 endpoint. Concentrations at which there is no survival in any of the test chambers are excluded from statistical analysis of the NOEC and LOEC, but included in the estimation of the LC, EC, and IC endpoints.

14.13.2.2 For the case of equal numbers of replicates across all concentrations and the control, the evaluation of the NOEC and LOEC endpoints is made via a parametric test, Dunnett's Procedure, or a nonparametric test, Steel's Many-one Rank Test, on the arc sine square root transformed data. Underlying assumptions of Dunnett's Procedure, normality and homogeneity of variance, are formally tested. The test for normality is the Shapiro-Wilk's Test, and Bartlett's Test is used to test for homogeneity of variance. If either of these tests fails, the nonparametric test, Steel's Many-one Rank Test, is used to determine the NOEC and LOEC endpoints. If the assumptions of Dunnett's Procedure are met, the endpoints are estimated by the parametric procedure.

14.13.2.3 If unequal numbers of replicates occur among the concentration levels tested, there are parametric and nonparametric alternative analyses. The parametric analysis is a t-test with the Bonferroni adjustment (see Appendix D). The Wilcoxon Rank Sum Test with the Bonferroni adjustment is the nonparametric alternative.

14.13.2.4 Probit Analysis (Finney, 1971; see Appendix G) is used to estimate the concentration that causes a specified percent decrease in survival from the control. In this analysis, the total mortality data from all test replicates at a given concentration are combined. If the data do not fit the Probit model, the Spearman-Kärber method, the Trimmed Spearman-Kärber method, or the Graphical method may be used (see Appendices H-K).

14.13.2.5 The proportion of survival in each replicate must first be transformed by the arc sine transformation procedure described in Appendix B. The raw and transformed data, means and variances of the transformed observations at each concentration including the control are listed in Table 5. A plot of the survival data is provided in Figure 11.

STATISTICAL ANALYSIS OF *MYSIDOPSIS BAHIA*
SURVIVAL, GROWTH, AND FECUNDITY TEST

SURVIVAL HYPOTHESIS TESTING

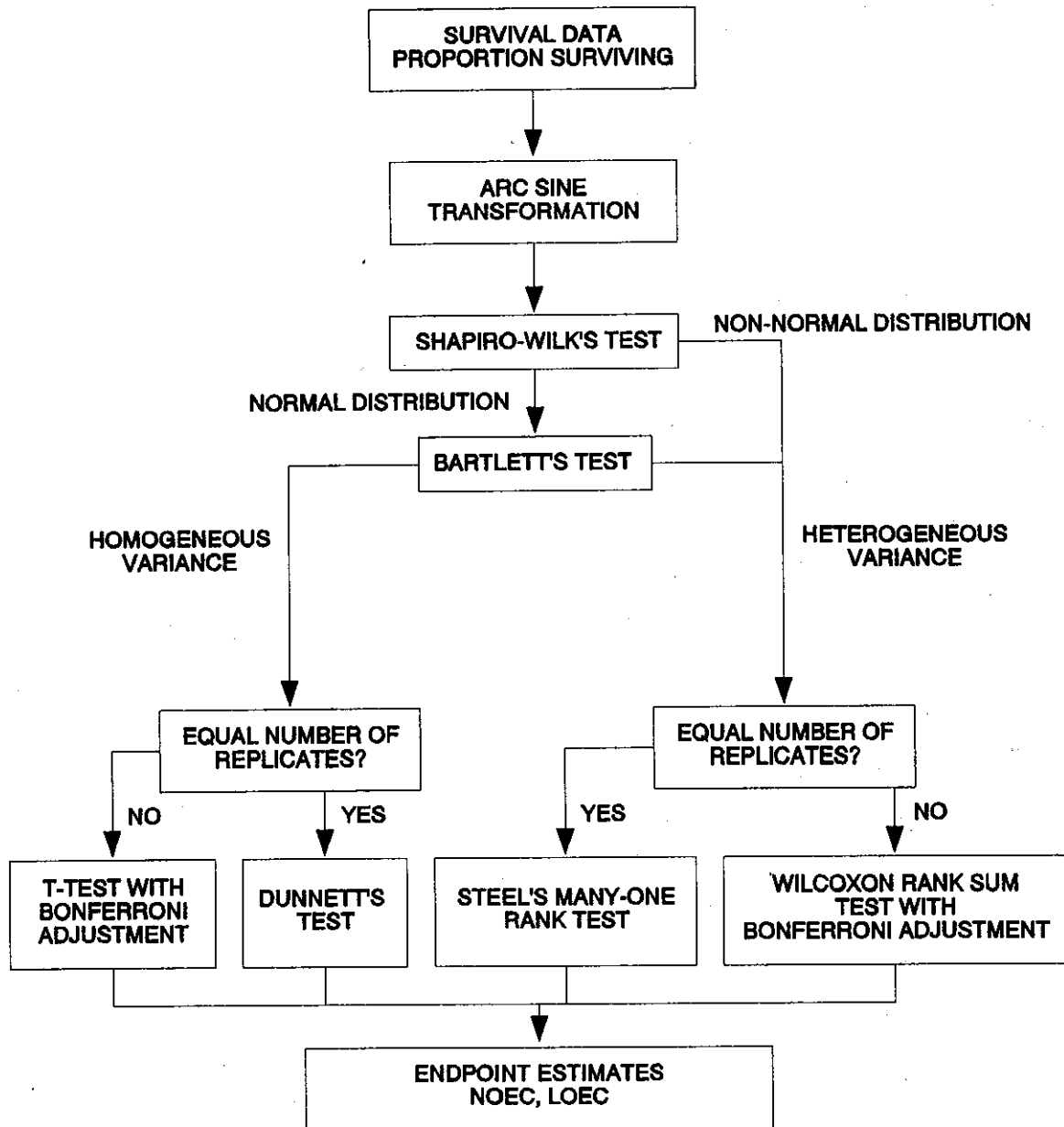

Figure 9. Flowchart for statistical analysis of mysid, *Mysidopsis bahia*, survival data by hypothesis testing.

**STATISTICAL ANALYSIS OF *MYSIDOPSIS BAHIA*
SURVIVAL, GROWTH, AND FECUNDITY TEST**

SURVIVAL POINT ESTIMATION

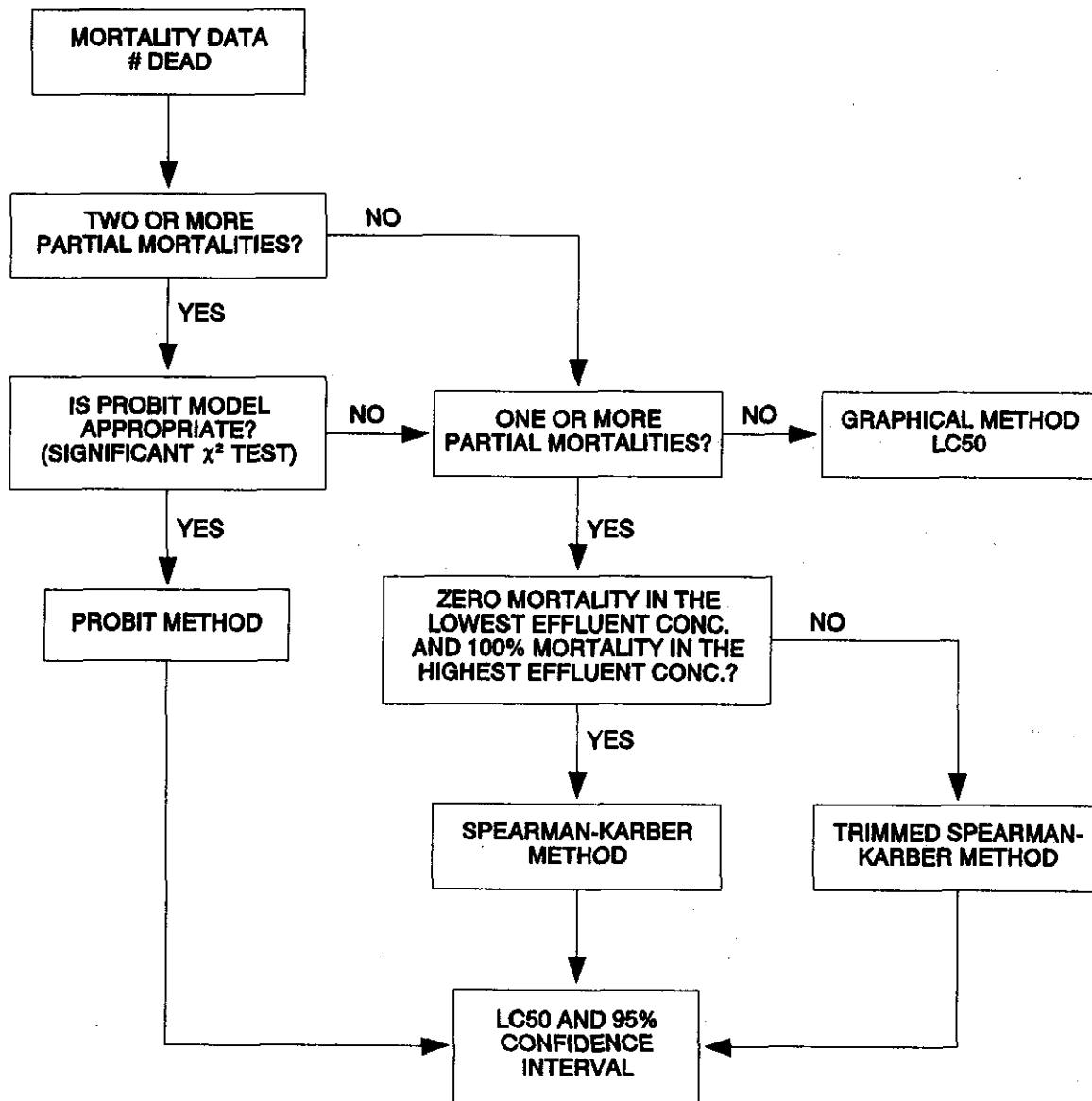

Figure 10. Flowchart for statistical analysis of mysid, *Mysidopsis bahia*, survival data by point estimation.

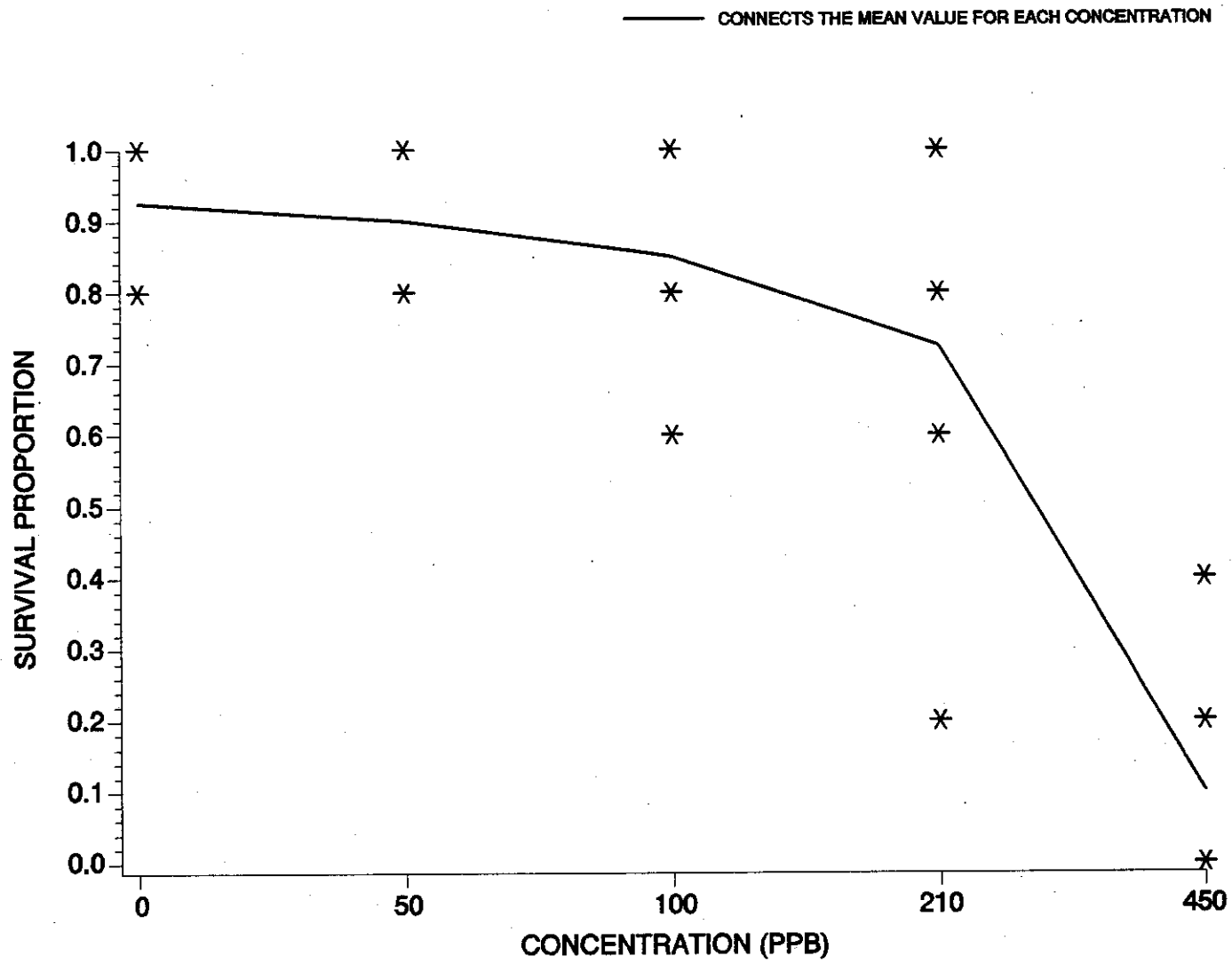

Figure 11. Plot of survival proportions of mysids, *Mysidopsis bahia*, at each treatment level.

TABLE 5. MYSID, *MYSIDOPSIS BAHIA*, SURVIVAL DATA

	Replicate	Control	Concentration (ppb)			
			50.0	100.0	210.0	450.0
RAW	1	0.80	0.80	0.60	1.00	0.00
	2	0.80	1.00	1.00	0.80	0.20
	3	1.00	0.80	1.00	0.20	0.00
	4	1.00	0.80	1.00	0.80	0.20
	5	1.00	1.00	1.00	0.60	0.00
	6	1.00	1.00	0.60	0.80	0.00
	7	1.00	0.80	0.80	0.80	0.00
	8	0.80	1.00	0.80	0.80	0.40
ARC SINE TRANS- FORMED	1	1.107	1.107	0.886	1.345	0.225
	2	1.107	1.345	1.345	1.107	0.464
	3	1.345	1.107	1.345	0.464	0.225
	4	1.345	1.107	1.345	1.107	0.464
	5	1.345	1.345	1.345	0.886	0.225
	6	1.345	1.345	0.886	1.107	0.225
	7	1.345	1.107	1.107	1.107	0.225
	8	1.107	1.345	1.107	1.107	0.685
Mean(Y_i)		1.256	1.226	1.171	1.029	0.342
S_i^2		0.015	0.016	0.042	0.067	0.031
i		1	2	3	4	5

14.13.2.6 Test for Normality

14.13.2.6.1 The first step of the test for normality is to center the observations by subtracting the mean of all observations within a concentration from each observation in that concentration. The centered observations are listed in Table 6.

14.13.2.6.2 Calculate the denominator, D, of the test statistic:

$$D = \sum_{i=1}^n (X_i - \bar{X})^2$$

Where: X_i = the i th centered observation

\bar{X} = the overall mean of the centered observations

n = the total number of centered observations.

TABLE 6. CENTERED OBSERVATIONS FOR SHAPIRO-WILK'S EXAMPLE

Replicate	Control (Site Water)	Concentration			
		50.0	100.0	210.0	450.0
1	-0.149	-0.119	-0.285	0.316	-0.117
2	-0.149	0.119	0.174	0.078	0.121
3	0.089	-0.119	0.174	-0.565	-0.117
4	0.089	-0.119	0.174	0.078	0.121
5	0.089	0.119	0.174	-0.142	-0.117
6	0.089	0.119	-0.285	0.078	-0.117
7	0.089	-0.119	-0.064	0.078	-0.117
8	-0.149	0.119	-0.064	0.078	0.342

14.13.2.6.3 For this set of data, $n = 40$

$$\bar{X} = \frac{1}{40}(-0.006) = 0.0$$

$$D = 1.197$$

14.13.2.6.4 Order the centered observations from smallest to largest:

$$X^{(1)} \leq X^{(2)} \leq \dots \leq X^{(n)}$$

Where $X^{(i)}$ is the i th ordered observation. These ordered observations are listed in Table 7.

14.13.2.6.5 From Table 4, Appendix B, for the number of observations, n , obtain the coefficients a_1, a_2, \dots, a_k where k is $n/2$ if n is even and $(n-1)/2$ if n is odd. For the data in this example, $n = 40$ and $k = 20$. The a_i values are listed in Table 8.

14.13.2.6.6 Compute the test statistic, W , as follows:

$$W = \frac{1}{D} \left[\sum_{i=1}^k a_i (X^{(n-i+1)} - X^{(i)}) \right]^2$$

The differences $X^{(n-i+1)} - X^{(i)}$ are listed in Table 7. For this data in this example:

TABLE 7. ORDERED CENTERED OBSERVATIONS FOR SHAPIRO-WILK'S EXAMPLE

i	$X^{(i)}$	i	$X^{(i)}$
1	-0.565	21	0.078
2	-0.285	22	0.078
3	-0.285	23	0.078
4	-0.149	24	0.089
5	-0.149	25	0.089
6	-0.149	26	0.089
7	-0.143	27	0.089
8	-0.119	28	0.089
9	-0.119	29	0.119
10	-0.119	30	0.119
11	-0.119	31	0.119
12	-0.117	32	0.119
13	-0.117	33	0.121
14	-0.117	34	0.121
15	-0.117	35	0.174
16	-0.117	36	0.174
17	-0.064	37	0.174
18	-0.064	38	0.174
19	0.078	39	0.316
20	0.078	40	0.342

$$W = \frac{1}{1.197} (1.0475)^2 = 0.9167$$

14.13.2.6.7 The decision rule for this test is to compare W as calculated in Subsection 14.13.2.6.5 with the critical value found in Table 6, Appendix B. If the computed W is less than the critical value, conclude that the data are not normally distributed. For this set of data, the critical value at a significance level of 0.01 and $n = 40$ observations is 0.919. Since $W = 0.9167$ is less than the critical value, conclude that the data are not normally distributed.

14.13.2.6.8 Since the data do not meet the assumption of normality, Steel's Many-one Rank Test will be used to analyze the survival data.

14.13.2.7 Steel's Many-one Rank Test

14.13.2.7.1 For each control and concentration combination, combine the data and arrange the observations in order of size from smallest to largest. Assign the ranks (1, 2, ..., 16) to the ordered observations with a rank of 1 assigned to the smallest observation, rank of 2 assigned to the next larger

TABLE 8. COEFFICIENTS AND DIFFERENCES FOR SHAPIRO-WILK'S EXAMPLE

i	a_i	$\chi^{(n-i+1)} - \chi^{(i)}$	
1	0.3964	0.907	$\chi^{(40)} - \chi^{(1)}$
2	0.2737	0.601	$\chi^{(39)} - \chi^{(2)}$
3	0.2368	0.459	$\chi^{(38)} - \chi^{(3)}$
4	0.2098	0.323	$\chi^{(37)} - \chi^{(4)}$
5	0.1878	0.323	$\chi^{(36)} - \chi^{(5)}$
6	0.1691	0.323	$\chi^{(35)} - \chi^{(6)}$
7	0.1526	0.264	$\chi^{(34)} - \chi^{(7)}$
8	0.1376	0.240	$\chi^{(33)} - \chi^{(8)}$
9	0.1237	0.238	$\chi^{(32)} - \chi^{(9)}$
10	0.1108	0.238	$\chi^{(31)} - \chi^{(10)}$
11	0.0986	0.238	$\chi^{(30)} - \chi^{(11)}$
12	0.0870	0.236	$\chi^{(29)} - \chi^{(12)}$
13	0.0759	0.206	$\chi^{(28)} - \chi^{(13)}$
14	0.0651	0.206	$\chi^{(27)} - \chi^{(14)}$
15	0.0546	0.206	$\chi^{(26)} - \chi^{(15)}$
16	0.0444	0.206	$\chi^{(25)} - \chi^{(16)}$
17	0.0343	0.153	$\chi^{(24)} - \chi^{(17)}$
18	0.0244	0.142	$\chi^{(23)} - \chi^{(18)}$
19	0.0146	0.0	$\chi^{(22)} - \chi^{(19)}$
20	0.0049	0.0	$\chi^{(21)} - \chi^{(20)}$

observation, etc. If ties occur when ranking, assign the average rank to each tied observation.

14.13.2.7.2 An example of assigning ranks to the combined data for the control and 50.0 ppb concentration is given in Table 9. This ranking procedure is repeated for each control/concentration combination. The complete set of rankings is summarized in Table 10. The ranks are then summed for each concentration level, as shown in Table 11.

14.13.2.7.3 For this example, determine if the survival in any of the concentrations is significantly lower than the survival in the control. If this occurs, the rank sum at that concentration would be significantly lower than the rank sum of the control. Thus compare the rank sums for the survival at each of the various concentration levels with some "minimum" or critical rank sum, at or below which the survival would be considered significantly lower than the control. At a significance level of 0.05, the minimum rank sum in a test with four concentrations (excluding the control) and eight replicates is 47 (See Table 5, Appendix E).

14.13.2.7.4 Since the rank sum for the 450 ppb concentration level is less than the critical value, the proportion surviving in that concentration is considered significantly less than that in the control. Since no other rank

TABLE 9. ASSIGNING RANKS TO THE CONTROL AND 50 PPB CONCENTRATION LEVEL FOR STEEL'S MANY-ONE RANK TEST

Rank	Transformed Proportion of Total Mortality	Concentration
4	1.107	Control
4	1.107	Control
4	1.107	Control
4	1.107	50 ppb
4	1.107	50 ppb
4	1.107	50 ppb
4	1.107	50 ppb
12	1.571	Control
12	1.571	Control
12	1.571	Control
12	1.571	Control
12	1.571	Control
12	1.571	50 ppb
12	1.571	50 ppb
12	1.571	50 ppb
12	1.571	50 ppb

sums are less than or equal to the critical value, no other concentrations have a significantly lower proportion surviving than the control. Hence, the NOEC and the LOEC are assumed to be 210.0 ppb and 450.0 ppb, respectively.

14.13.2.8 Calculation of the LC50

14.13.2.8.1 The data used for the Probit Analysis is summarized in Table 12. For the Probit Analysis, run the USEPA Probit Analysis Program. An example of the program output is provided in Figure 12.

14.13.2.8.2 For this example, the chi-square test for heterogeneity was not significant. Thus Probit Analysis appears to be appropriate for this set of data.

14.13.3 EXAMPLE OF ANALYSIS OF MYSID, *MYSIDOPSIS BAHIA* GROWTH DATA

14.13.3.1 Formal statistical analysis of the growth data is outlined in Figure 13. The response used in the statistical analysis is mean weight per original of males and females combined per replicate. The IC25 and IC50 can be calculated for the growth data via a point estimation technique (see Section 9, Chronic Toxicity Test Endpoints and Data Analysis). Hypothesis testing can be used to obtain an NOEC and LOEC for growth. Concentrations above the NOEC for survival are excluded from the hypothesis test for growth effects.

TABLE 10. TABLE OF RANKS¹

Repli- cate	Control	Concentration (ppb)			
		50	100	210	450
1	1.107(4,5,6.5,10)	1.107(4)	0.886(1.5)	1.345(13.5)	0.225(3)
2	1.107(4,5,6.5,10)	1.345(12)	1.345(12)	1.107(6.5)	0.464(6.5)
3	1.345(12,12,13.5,14)	1.107(4)	1.345(12)	0.464(1)	0.225(3)
4	1.345(12,12,13.5,14)	1.107(4)	1.345(12)	1.107(6.5)	0.464(6.5)
5	1.345(12,12,13.5,14)	1.345(12)	1.345(12)	0.886(2)	0.225(3)
6	1.345(12,12,13.5,14)	1.345(12)	0.886(1.5)	1.107(6.5)	0.225(3)
7	1.345(12,12,13.5,14)	1.107(4)	1.107(5)	1.107(6.5)	0.225(3)
8	1.107(4,5,6.5,10)	1.345(12)	1.107(5)	1.107(6.5)	0.685(8)

¹Control ranks are given in the order of the concentration with which they were ranked.

TABLE 11. RANK SUMS

Concentration	Rank Sum
50	64
100	61
210	49
450	36

14.13.3.2 The statistical analysis using hypothesis tests consists of a parametric test, Dunnett's Procedure, and a nonparametric test, Steel's Many-one Rank Test. The underlying assumptions of the Dunnett's Procedure, normality and homogeneity of variance, are formally tested. The test for normality is the Shapiro-Wilk's Test and Bartlett's Test is used to test for homogeneity of variance. If either of these tests fails, the nonparametric test, Steel's Many-one Rank Test, is used to determine the NOEC and LOEC endpoints. If the assumptions of Dunnett's Procedure are met, the endpoints are determined by the parametric test.

14.13.3.3 Additionally, if unequal numbers of replicates occur among the concentration levels tested, there are parametric and nonparametric alternative analyses. The parametric analysis is a t test with the Bonferroni adjustment. The Wilcoxon Rank Sum Test with the Bonferroni adjustment is the

Probit Analysis of *Mysidopsis bahia* Survival Data

Conc.	Number Exposed	Number Resp.	Observed Proportion Responding	Proportion Responding Adjusted for Controls
Control	40	3	0.0750	0.0000
50.0000	40	4	0.1000	-.0080
100.0000	40	6	0.1500	0.0480
210.0000	40	11	0.2750	0.1880
450.0000	40	36	0.9000	0.8880

Chi - Square for Heterogeneity (calculated) = 0.725
 Chi - Square for Heterogeneity (tabular value) = 5.991

Probit Analysis of *Mysidopsis bahia* Survival Data

Estimated LC/EC Values and Confidence Limits

Point	Exposure Conc.	Lower 95% Confidence	Upper Limits
LC/EC 1.00	123.112	65.283	165.552
LC/EC 50.00	288.873	239.559	335.983

Figure 12. Output for USEPA Probit Analysis Program, version 1.5.

TABLE 12. DATA FOR PROBIT ANALYSIS

	Control	Concentration (ppb)			
		50.0	100.0	210.0	450.0
No Dead	3	4	6	11	36
No Exposed	40	40	40	40	40

nonparametric alternative. For detailed information on the Bonferroni adjustment, see Appendix D.

14.13.3.4 The data, mean and variance of the observations at each concentration including the control for this example are listed in Table 13. A plot of the data is provided in Figure 14. Since there is significant mortality in the 450 ppb concentration, its effect on growth is not considered.

TABLE 13. MYSID, *MYSIDOPSIS BAHIA*, GROWTH DATA

Replicate	Control	Concentration (ppb)			
		50.0	100.0	210.0	450.0
1	0.146	0.157	0.114	0.153	-
2	0.118	0.193	0.172	0.071	0.012
3	0.216	0.190	0.160	0.017	-
4	0.199	0.190	0.199	0.112	0.002
5	0.176	0.256	0.165	0.052	-
6	0.243	0.191	0.145	0.154	-
7	0.213	0.122	0.207	0.110	-
8	0.144	0.177	0.186	0.103	0.081
Mean (\bar{Y}_i)	0.182	0.184	0.168	0.101	-
S_i^2	0.00186	0.00145	0.00091	0.00222	-
n_i	1	2	3	4	5

14.13.3.5 Test for Normality

14.13.3.5.1 The first step of the test for normality is to center the observations by subtracting the mean of all observations within a

**STATISTICAL ANALYSIS OF *MYSIDOPSIS BAHIA*
SURVIVAL, GROWTH, AND FECUNDITY TEST**

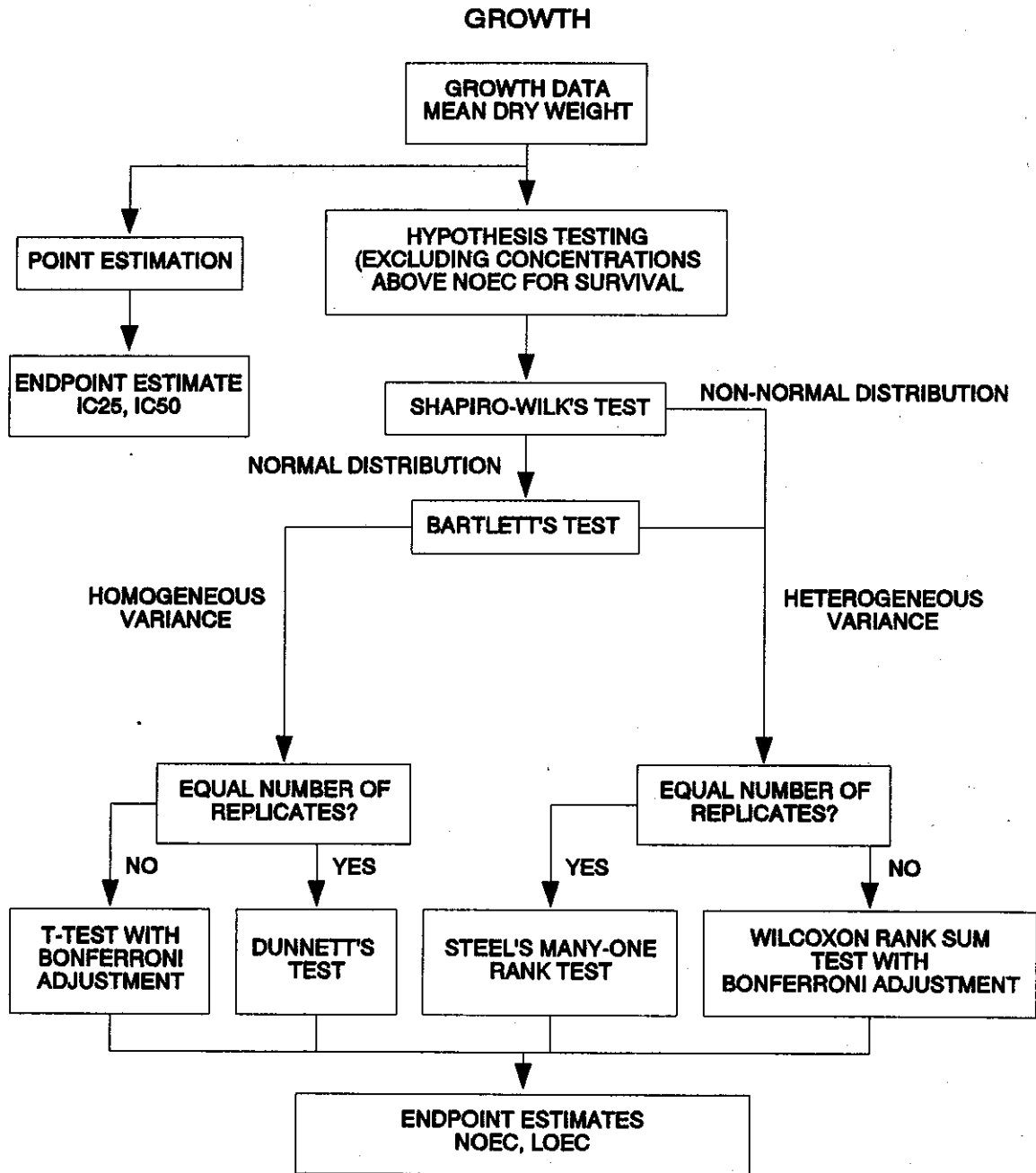

Figure 13. Flowchart for statistical analysis of mysid, *Mysidopsis bahia*, growth data.

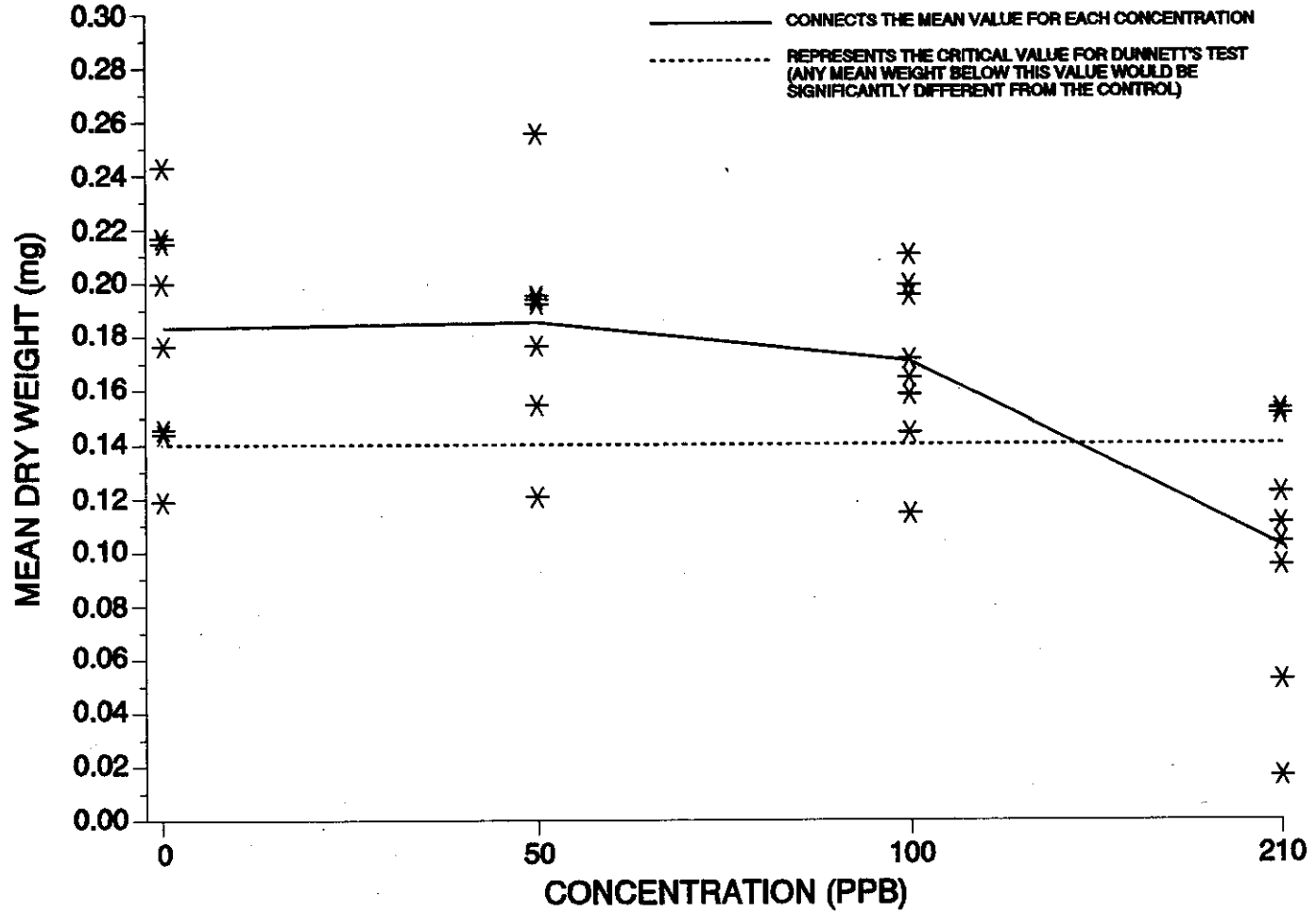

Figure 14. Plot of mean growth data for mysid, *Mysidopsis bahia*, test.

concentration from each observation in that concentration. The centered observations are listed in Table 14.

TABLE 14. CENTERED OBSERVATIONS FOR SHAPIRO-WILK'S EXAMPLE

Replicate	Control	Concentration (ppb)		
		50.0	100.0	210.0
1	-0.036	-0.030	-0.054	0.052
2	-0.064	0.009	0.004	-0.007
3	0.034	0.006	-0.008	-0.084
4	0.017	0.006	0.031	0.021
5	-0.006	0.072	-0.003	-0.049
6	0.061	0.007	-0.023	0.053
7	0.031	-0.062	0.039	0.009
8	-0.038	-0.007	0.018	0.002

14.13.3.5.2 Calculate the denominator, D, of the statistic:

$$D = \sum_{i=1}^n (X_i - \bar{X})^2$$

Where: X_i = the i th centered observation

\bar{X} = the overall mean of the centered observations

n = the total number of centered observations

14.13.3.5.3 For this set of data, $n = 32$

$$\bar{X} = \frac{1}{32} (0.007) = 0.000$$

$$D = 0.0451$$

14.13.3.5.4 Order the centered observations from smallest to largest

$$X^{(1)} \leq X^{(2)} \leq \dots \leq X^{(n)}$$

where $X^{(i)}$ denotes the i th ordered observation. The ordered observations for this example are listed in Table 15.

TABLE 15. ORDERED CENTERED OBSERVATIONS FOR SHAPIRO-WILK'S EXAMPLE

i	$\chi^{(i)}$	i	$\chi^{(i)}$
1	-0.084	17	0.006
2	-0.064	18	0.006
3	-0.062	19	0.007
4	-0.054	20	0.009
5	-0.049	21	0.009
6	-0.038	22	0.017
7	-0.036	23	0.018
8	-0.030	24	0.021
9	-0.023	25	0.031
10	-0.008	26	0.031
11	-0.007	27	0.034
12	-0.007	28	0.039
13	-0.006	29	0.052
14	-0.003	30	0.053
15	0.002	31	0.061
16	0.004	32	0.072

14.13.3.5.5 From Table 4, Appendix B, for the number of observations, n , obtain the coefficients a_1, a_2, \dots, a_k where k is $n/2$ if n is even and $(n-1)/2$ if n is odd. For the data in this example, $n = 32$ and $k = 16$. The a_i values are listed in Table 16.

14.13.3.5.6 Compute the test statistic, W , as follows:

$$W = \frac{1}{D} \left[\sum_{i=1}^k a_i (X^{(n-i+1)} - X^{(i)}) \right]^2$$

The differences $X^{(n-i+1)} - X^{(i)}$ are listed in Table 16. For this set of data:

$$W = \frac{1}{0.045} (0.2097)^2 = 0.9752$$

14.13.3.5.7 The decision rule for this test is to compare W as calculated in Subsection 14.13.3.5.6 to a critical value found in Table 6, Appendix B. If the computed W is less than the critical value, conclude that the data are not normally distributed. For this set of data, the critical value at a significance level of 0.01 and $n = 32$ observations is 0.904. Since $W = 0.9752$ is greater than the critical value, conclude that the data are normally distributed.

TABLE 16. COEFFICIENTS AND DIFFERENCES FOR SHAPIRO-WILK'S EXAMPLE

i	a _i	X ⁽ⁿ⁻ⁱ⁺¹⁾ - X ⁽ⁱ⁾	
1	0.4188	0.156	X ⁽³²⁾ - X ⁽¹⁾
2	0.2898	0.125	X ⁽³¹⁾ - X ⁽²⁾
3	0.2462	0.115	X ⁽³⁰⁾ - X ⁽³⁾
4	0.2141	0.106	X ⁽²⁹⁾ - X ⁽⁴⁾
5	0.1878	0.088	X ⁽²⁸⁾ - X ⁽⁵⁾
6	0.1651	0.072	X ⁽²⁷⁾ - X ⁽⁶⁾
7	0.1449	0.067	X ⁽²⁶⁾ - X ⁽⁷⁾
8	0.1265	0.061	X ⁽²⁵⁾ - X ⁽⁸⁾
9	0.1093	0.044	X ⁽²⁴⁾ - X ⁽⁹⁾
10	0.0931	0.026	X ⁽²³⁾ - X ⁽¹⁰⁾
11	0.0777	0.024	X ⁽²²⁾ - X ⁽¹¹⁾
12	0.0629	0.016	X ⁽²¹⁾ - X ⁽¹²⁾
13	0.0485	0.015	X ⁽²⁰⁾ - X ⁽¹³⁾
14	0.0344	0.010	X ⁽¹⁹⁾ - X ⁽¹⁴⁾
15	0.0206	0.004	X ⁽¹⁸⁾ - X ⁽¹⁵⁾
16	0.0068	0.002	X ⁽¹⁷⁾ - X ⁽¹⁶⁾

14.13.3.6 Test for Homogeneity of Variance

14.13.3.6.1 The test used to examine whether the variation in mean weight of the mysids is the same across all concentration levels including the control, is Bartlett's Test (Snedecor and Cochran, 1980). The test statistic is as follows:

$$B = \frac{[(\sum_{i=1}^p V_i) \ln \bar{S}^2 - \sum_{i=1}^p V_i \ln S_i^2]}{C}$$

Where: V_i = degrees of freedom for each copper concentration and control, V_i = (n_i - 1)

p = number of concentration levels including the control

ln = log_e

i = 1, 2, ..., p where p is the number of concentrations including the control

n_i = the number of replicates for concentration i.

$$\bar{S}^2 = \frac{(\sum_{i=1}^p V_i S_i^2)}{\sum_{i=1}^p V_i}$$

$$C = 1 + [3(p-1)]^{-1} [\sum_{i=1}^p 1/V_i - (\sum_{i=1}^p V_i)^{-1}]$$

14.13.3.6.2 For the data in this example (See Table 13), all concentrations including the control have the same number of replicates ($n_i = 8$ for all i). Thus, $V_i = 7$ for all i .

14.13.3.6.3 Bartlett's statistic is therefore:

$$\begin{aligned} B &= [(28) \ln(0.0016) - 7 \sum_{i=1}^p \ln(S_i^2)] / 1.06 \\ &= [28(-6.4315) - 7(-25.9357)] / 1.06 \\ &= [-180.082 - (-181.5499)] / 1.06 \\ &= 1.385 \end{aligned}$$

14.13.3.6.4 B is approximately distributed as chi-square with $p - 1$ degrees of freedom, when the variances are in fact the same. Therefore, the appropriate critical value for this test, at a significance level of 0.01 with three degrees of freedom, is 9.210. Since $B = 1.385$ is less than the critical value of 9.210, conclude that the variances are not different.

14.13.3.7 Dunnett's Procedure

14.13.3.7.1 To obtain an estimate of the pooled variance for the Dunnett's Procedure, construct an ANOVA table as described in Table 17.

TABLE 17. ANOVA TABLE

Source	df	Sum of Squares (SS)	Mean Square (MS) (SS/df)
Between	$p - 1$	SSB	$S_B^2 = \text{SSB}/(p-1)$
Within	$N - p$	SSW	$S_W^2 = \text{SSW}/(N-p)$
Total	$N - 1$	SST	

Where: p = number of concentration levels including the control

N = total number of observations $n_1 + n_2 \dots + n_p$

n_i = number of observations in concentration i .

$$SSB = \sum_{i=1}^p T_i^2/n_i - G^2/N \quad \text{Between Sum of Squares}$$

$$SST = \sum_{i=1}^p \sum_{j=1}^{n_i} Y_{ij}^2 - G^2/N \quad \text{Total Sum of Squares}$$

$$SSW = SST - SSB \quad \text{Within Sum of Squares}$$

G = the grand total of all sample observations, $G = \sum_{i=1}^p T_i$

T_i = the total of the replicate measurements for concentration i

Y_{ij} = the j th observation for concentration i (represents the mean dry weight of the mysids for concentration i in test chamber j)

14.13.3.7.2 For the data in this example:

$$n_1 = n_2 = n_3 = n_4 = 8$$

$$N = 32$$

$$T_1 = Y_{11} + Y_{12} + \dots + Y_{18} = 1.455$$

$$T_2 = Y_{21} + Y_{22} + \dots + Y_{28} = 1.473$$

$$T_3 = Y_{31} + Y_{32} + \dots + Y_{38} = 1.348$$

$$T_4 = Y_{41} + Y_{42} + \dots + Y_{48} = 0.805$$

$$G = T_1 + T_2 + T_3 + T_4 = 5.081$$

$$\begin{aligned} SSB &= \sum_{i=1}^p T_i^2/n_i - G^2/N \\ &= \frac{1}{8} (6.752) - \frac{(5.081)^2}{32} = 0.0372 \end{aligned}$$

$$\begin{aligned} SST &= \sum_{i=1}^p \sum_{j=1}^{n_i} Y_{ij}^2 - G^2/N \\ &= 0.889 - \frac{(5.081)^2}{32} = 0.0822 \end{aligned}$$

$$SSW = SST - SSB = 0.0822 - 0.0372 = 0.0450$$

$$S_B^2 = SSB / (p-1) = 0.0372 / (4-1) = 0.0124$$

$$S_W^2 = SSW / (N-p) = 0.0450 / (32-4) = 0.0016$$

14.13.3.7.3 Summarize these calculations in the ANOVA table (Table 18).

TABLE 18. ANOVA TABLE FOR DUNNETT'S PROCEDURE EXAMPLE

Source	df	Sum of Squares (SS)	Mean Square (MS) (SS/df)
Between	3	0.0372	0.0127
Within	28	0.0450	0.0016
Total	31	0.0822	

14.13.3.7.4 To perform the individual comparisons, calculate the t statistic for each concentration, and control combination as follows:

$$t_i = \frac{(\bar{Y}_1 - \bar{Y}_i)}{S_w \sqrt{(1/n_1) + (1/n_i)}}$$

Where: \bar{Y}_i = mean dry weight for concentration i

\bar{Y}_1 = mean dry weight for the control

S_w = square root of the within mean square

n_1 = number of replicates for the control

n_i = number of replicates for concentration i

14.13.3.7.5 Table 19 includes the calculated t values for each concentration and control combination. In this example, comparing the 50.0 ppb concentration with the control the calculation is as follows:

$$t_2 = \frac{(0.182-0.184)}{[0.040\sqrt{(1/8)+(1/8)}]}$$

$$= -0.100$$

TABLE 19. CALCULATED T VALUES

Concentration (ppb)	i	t _i
50.0	2	-0.150
100.0	3	0.700
210.0	4	4.050

14.13.3.7.6 Since the purpose of this test is to detect a significant reduction in mean weight, a one-sided test is appropriate. The critical value for this one-sided test is found in Table 5, Appendix C. For an overall alpha level of 0.05, 28 degrees of freedom for error and three concentrations (excluding the control) the approximate critical value is 2.15. The mean weight for concentration "i" is considered significantly less than the mean weight for the control if t_i is greater than the critical value. Therefore, the 210.0 ppb concentration has significantly lower mean weight than the control. Hence the NOEC and the LOEC for growth are 100.0 ppb and 210.0 ppb, respectively.

14.13.3.7.7 To quantify the sensitivity of the test, the minimum significant difference (MSD) that can be detected statistically may be calculated.

$$MSD = d S_w \sqrt{(1/n_1) + (1/n)}$$

Where: d = the critical value for Dunnett's Procedure

S_w = the square root of the within mean square

n = the common number of replicates at each concentration
(this assumes equal replication at each concentration)

n₁ = the number of replicates in the control.

14.13.3.7.8 In this example:

$$MSD = 2.15 (0.04) \sqrt{(1/8) + (1/8)}$$

$$= 2.15 (0.04) (0.5)$$

$$= 0.043$$

14.13.3.7.9 Therefore, for this set of data, the minimum difference that can be detected as statistically significant is 0.043 mg.

14.13.3.7.10 This represents a 23.6% reduction in mean weight from the control.

14.13.3.8 Calculation of the ICp

14.13.3.8.1 The growth data from Table 13 are utilized in this example. As seen in , the observed means are not monotonically non-increasing with respect to concentration. Therefore, it is necessary to smooth the means prior to calculating the IC. In the following discussion, the observed means are represented by \bar{Y}_i and the smoothed means by M_i .

14.13.3.8.2 Starting with the control mean, $\bar{Y}_1 = 0.182$ and $\bar{Y}_2 = 0.184$, we see that $\bar{Y}_1 < \bar{Y}_2$. Calculate the smoothed means:

$$M_1 = M_2 = (\bar{Y}_1 + \bar{Y}_2)/2 = 0.183$$

14.13.3.8.3 Since $\bar{Y}_5 = 0.025 < \bar{Y}_4 = 0.101 < \bar{Y}_3 = 0.168 < M_2$, set $M_3 = 0.168$ and $M_4 = 0.101$, and $M_5 = 0.025$. Table 20 contains the smoothed means and Figure 15 gives a plot of the smoothed response curve.

TABLE 20. MYSID, *MYSIDOPSIS BAHIA*, MEAN GROWTH RESPONSE AFTER SMOOTHING

Toxicant Conc. (ppb)	i	Response Means \bar{Y}_i (mg)	Smoothed Mean M_i (mg)
Control	1	0.182	0.183
50.0	2	0.184	0.183
100.0	3	0.168	0.168
210.0	4	0.101	0.101
450.0	5	0.012	0.012

14.13.3.8.4 An IC25 and IC50 can be estimated using the Linear Interpolation Method. A 25% reduction in weight, compared to the controls, would result in a mean weight of 0.136 mg, where $M_1(1-p/100) = 0.183(1-25/100)$. A 50% reduction in mean dry weight, compared to the controls, would result in a mean weight of 0.091 mg. Examining the smoothed means and their associated concentrations (Table 20), the response, 0.136 mg, is bracketed by $C_3 = 100$ ppb and $C_4 = 210$ ppb. The response, 0.091 mg, is bracketed by $C_4 = 210$ ppb and $C_5 = 450$ ppb.

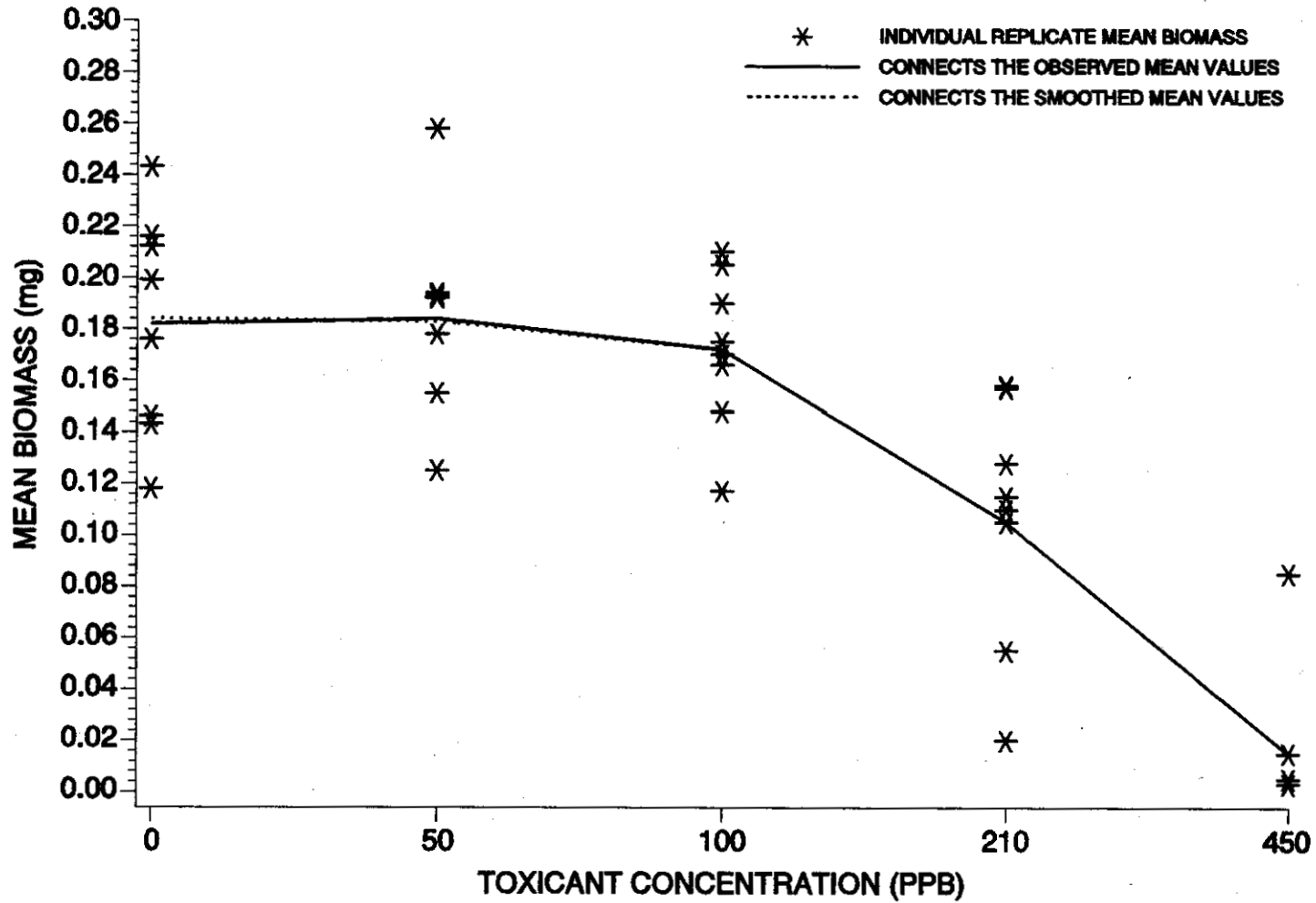

Figure 15. Plot of raw data, observed means, and smoothed means for the mysid, *Mysidopsis bahia*, growth data from Tables 13 and 20.

14.13.3.8.5 Using the equation in Section 4.2 from Appendix L, the estimate of the IC25 is calculated as follows:

$$IC_p = C_j + [M_1(1-p/100) - M_j] \frac{(C_{(j+1)} - C_j)}{(M_{(j+1)} - M_j)}$$

$$\begin{aligned} IC_{25} &= 100 + [0.183(1 - 25/100) - 0.168] \frac{(210 - 100)}{(0.101 - 0.168)} \\ &= 151 \text{ ppb.} \end{aligned}$$

14.13.3.8.6 Using Equation 1 from Appendix L, the estimate of the IC50 is calculated as follows:

$$IC_p = C_j + [M_1(1-p/100) - M_j] \frac{(C_{(j+1)} - C_j)}{(M_{(j+1)} - M_j)}$$

$$\begin{aligned} IC_{50} &= 210 + [0.183(1 - 50/100) - 0.101] \frac{(450 - 210)}{(0.012 - 0.101)} \\ &= 236 \text{ ppb.} \end{aligned}$$

14.13.3.8.7 When the ICPIN program was used to analyze this set of data, requesting 80 resamples, the estimate of the IC25 was 147.170 ppb. The empirical 95.0% confidence interval for the true mean was 97.0905 ppb and 186.6383 ppb. The computer program output for the IC25 for this data set is shown in Figure 16.

14.13.3.8.8 When the ICPIN program was used to analyze this set of data for the IC50, requesting 80 resamples, the estimate of the IC50 was 230.755 ppb. The empirical 95.7% confidence interval for the true mean was (183.84 ppb to 277.9211 ppb). The computer program output for the IC50 for this data set is shown in Figure 17.

14.13.4 EXAMPLE OF ANALYSIS OF MYSID, *MYSIDOPSIS BAHIA*, FECUNDITY DATA

14.13.4.1 Formal statistical analysis of the fecundity data is outlined in Figure 18. The response used in the statistical analysis is the proportion of females with eggs in each test or control chamber. If no females were present in a replicate, a response of zero should not be used. Instead there are no data available for that replicate and the number of replicates for that level of concentration or the control should be reduced by one. Separate analyses are performed for the estimation of the NOEC and LOEC endpoints, and for the estimation of the EC, LC, and IC endpoints. The data for a concentration are excluded from the statistical analysis of the NOEC and LOEC endpoints if no eggs were produced in all of the replicates in which females existed. However, all data are included in the estimation of the IC25 and IC50.

Conc. ID	1	2	3	4	5
Conc. Tested	0	50	100	210	450
Response 1	.146	.154	.114	.153	0
Response 2	.118	.19	.172	.094	.012
Response 3	.216	.193	.160	.017	0
Response 4	.199	.190	.199	.122	.002
Response 5	.176	.190	.165	.052	0
Response 6	.243	.191	.145	.154	0
Response 7	.213	.122	.207	.110	0
Response 8	.144	.177	.186	.103	.081

*** Inhibition Concentration Percentage Estimate ***

Toxicant/Effluent:

Test Start Date: Test Ending Date:

Test Species: MYSID SHRIMP, Mysidopsis bahia

Test Duration: growth test

DATA FILE: mysidwt.icp

OUTPUT FILE: mysidwt.i25

Conc. ID	Number Replicates	Concentration $\mu\text{g/l}$	Response Means	Std. Dev.	Pooled Response Means
1	8	0.000	0.182	0.043	0.183
2	8	50.000	0.184	0.038	0.183
3	8	100.000	0.168	0.030	0.168
4	8	210.000	0.101	0.047	0.101
5	8	450.000	0.012	0.028	0.012

The Linear Interpolation Estimate: 150.6446 Entered P Value: 25

Number of Resamplings: 80

The Bootstrap Estimates Mean: 147.1702 Standard Deviation: 23.7984

Original Confidence Limits: Lower: 97.0905 Upper: 186.6383

Resampling time in Seconds: 0.11 Random Seed: -1623038650

Figure 16. ICPIN program output for the IC25.

Conc. ID	1	2	3	4	5
Conc. Tested	0	50	100	210	450
Response 1	.146	.154	.114	.153	0
Response 2	.118	.193	.172	.094	.012
Response 3	.216	.190	.160	.017	0
Response 4	.199	.190	.199	.122	.002
Response 5	.176	.256	.165	.052	0
Response 6	.243	.191	.145	.154	0
Response 7	.213	.122	.207	.110	0
Response 8	.144	.177	.186	.103	.081

*** Inhibition Concentration Percentage Estimate ***

Toxicant/Effluent:

Test Start Date: Test Ending Date:

Test Species: MYSID SHRIMP, Mysidopsis bahia

Test Duration: growth test

DATA FILE: mysidwt.icp

OUTPUT FILE: mysidwt.i50

Conc. ID	Number Replicates	Concentration ug/l	Response Means	Std. Dev.	Pooled Response Means
1	8	0.000	0.182	0.043	0.183
2	8	50.000	0.184	0.038	0.183
3	8	100.000	0.168	0.030	0.168
4	8	210.000	0.101	0.047	0.101
5	8	450.000	0.012	0.028	0.012

The Linear Interpolation Estimate: 234.6761 Entered P Value: 50

Number of Resamplings: 80

The Bootstrap Estimates Mean: 230.7551 Standard Deviation: 30.6781

Original Confidence Limits: Lower: 183.8197 Upper: 277.9211

Resampling time in Seconds: 0.16 Random Seed: -628896314

Figure 17. ICPIN program output for the IC50.

**STATISTICAL ANALYSIS OF *MYSIDOPSIS BAHIA*
SURVIVAL, GROWTH, AND FECUNDITY TEST**

FECUNDITY

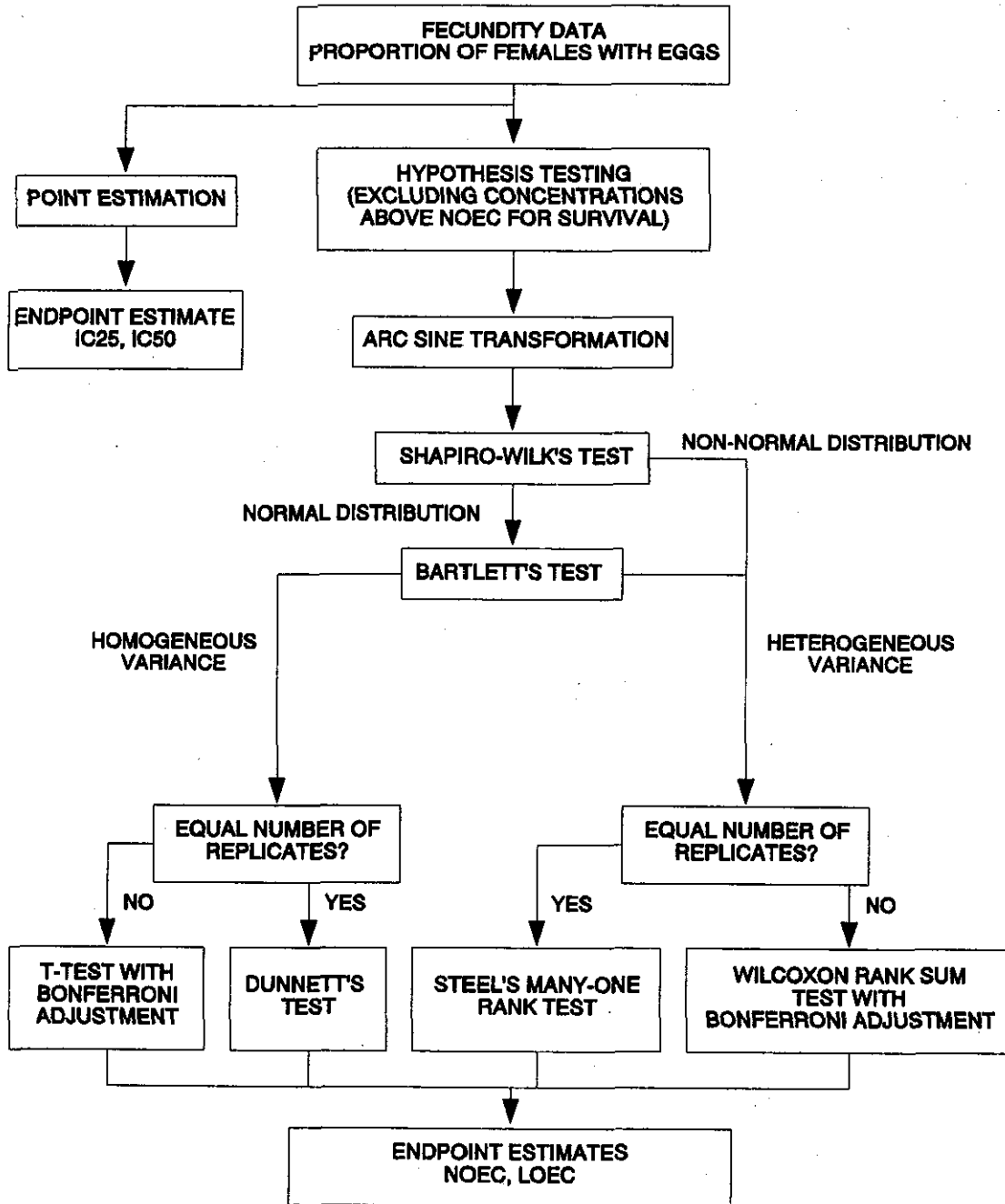

Figure 18. Flowchart for statistical analysis of mysid, *Mysidopsis bahia*, fecundity data.

14.13.4.2 For the case of equal numbers of replicates across all concentrations and the control, the evaluation of the NOEC and LOEC endpoints is made via a parametric test, Dunnett's Procedure, or a nonparametric test, Steel's Many-one Rank Test, on the arc sine square root transformed data. Underlying assumptions of Dunnett's Procedure, normality and homogeneity of variance, are formally tested. The test for normality is the Shapiro-Wilk's Test, and Bartlett's Test is used to test for homogeneity of variance. If either of these tests fails, the nonparametric test, Steel's Many-one Rank Test, is used to determine the NOEC and LOEC endpoints. If the assumptions of Dunnett's Procedure are met, the endpoints are estimated by the parametric procedure.

14.13.4.3 If unequal numbers of replicates occur among the concentration levels tested, there are parametric and nonparametric alternative analyses. The parametric analysis is a t test with the Bonferroni adjustment (Appendix D). The Wilcoxon Rank Sum Test with the Bonferroni adjustment is the nonparametric alternative.

14.13.4.4 The proportion of female mysids, *Mysidopsis bahia*, with eggs in each replicate must first be transformed by the arc sine square root transformation procedure described in Appendix B. Since the denominator of the proportion of females with eggs varies with the number of females occurring in that replicate, the adjustment of the arc sine square root transformation for 0% and 100% is not used for this data. The raw and transformed data, means and variances of the transformed observations at each test concentration including the control are listed in Table 21. Since there is significant mortality in the 450 ppb concentration, its effect on reproduction is not considered. Additionally, since no eggs were produced by females in any of the replicates for the 210 ppb concentration, it is not included in this statistical analysis and is considered a qualitative reproductive effect. A plot of the mean proportion of female mysids with eggs is illustrated in Figure 19.

14.13.4.5 Test for Normality

14.13.4.5.1 The first step of the test for normality is to center the observations by subtracting the mean of all observations within a concentration from each observation in that concentration. The centered observations are listed in Table 22.

14.13.4.5.2 Calculate the denominator, D, of the statistic:

$$D = \sum_{i=1}^n (X_i - \bar{X})^2$$

Where: X_i = the i th centered observation

\bar{X} = the overall mean of the centered observations

n = the total number of centered observations

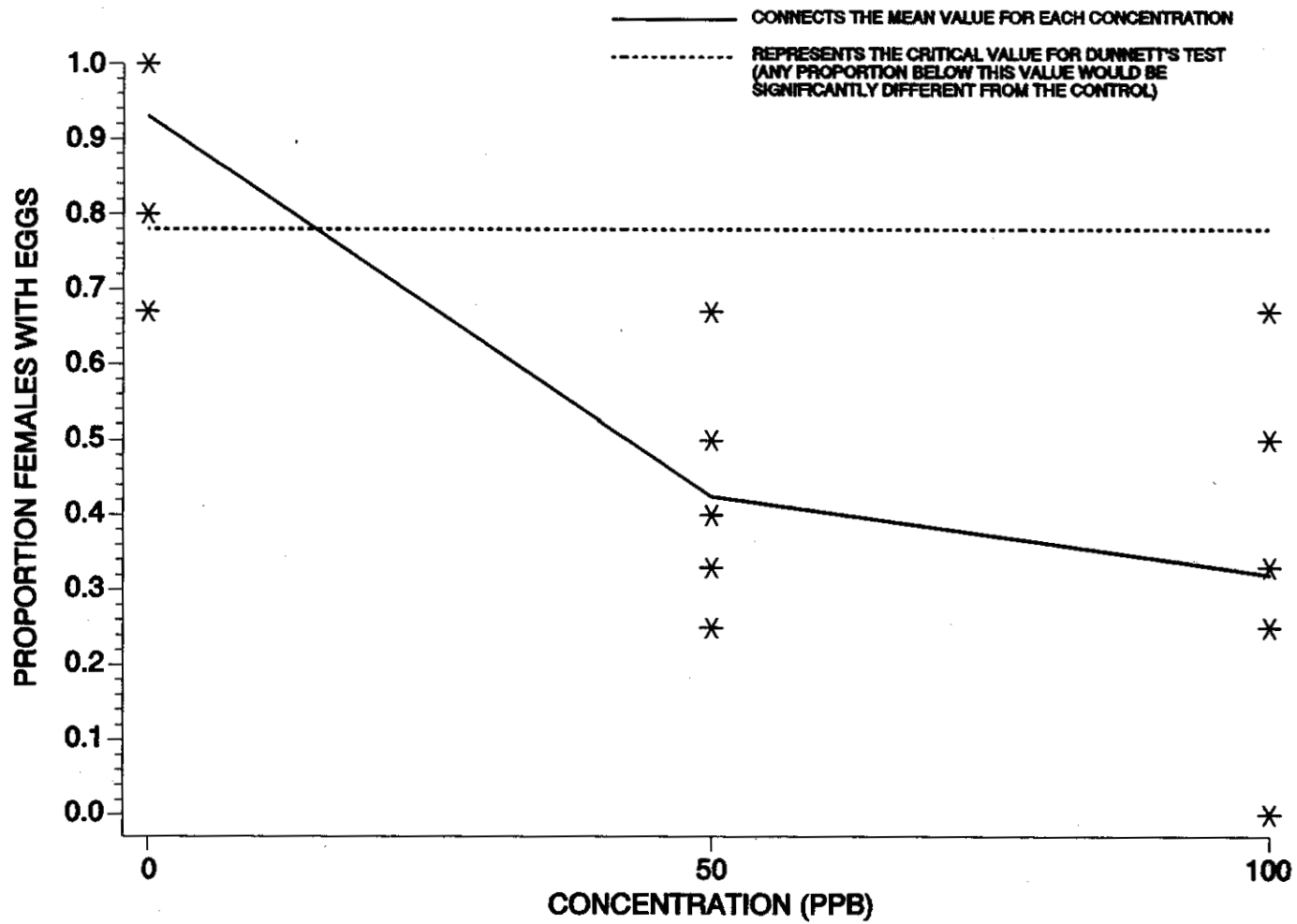

Figure 19. Proportion of females mysids, *Mysidopsis bahia*, with eggs.

TABLE 21. MYSID, *MYSIDOPSIS BAHIA*, FECUNDITY DATA: PERCENT FEMALES WITH EGGS

	Replicate	Control	Test Concentration (ppb)		
			50.0	100.0	210.0
RAW	1	1.00	0.50	0.33	0.0
	2	1.00	0.33	0.50	0.0
	3	0.67	0.67	0.00	0.0
	4	1.00	-	0.50	0.0
	5	1.00	0.40	0.67	0.0
	6	0.80	0.50	0.00	0.0
	7	1.00	0.25	0.25	0.0
	8	1.00	0.33	-	0.0
ARC SINE TRANS- FORMED	1	1.57	0.78	0.61	-
	2	1.57	0.61	0.78	-
	3	0.96	0.96	0.00	-
	4	1.57	-	0.78	-
	5	1.57	0.68	0.96	-
	6	1.12	0.78	0.00	-
	7	1.57	0.52	0.52	-
	8	1.57	0.61	-	-
Mean(\bar{Y}_i)		1.44	0.71	0.52	-
S_i^2		0.064	0.021	0.147	-
i		1	2	3	4

TABLE 22. CENTERED OBSERVATIONS FOR SHAPIRO-WILK'S EXAMPLE

Replicate	Control	Test Concentration (ppb)	
		50.0	100.0
1	0.13	0.07	0.09
2	0.13	-0.10	0.26
3	-0.48	0.25	-0.52
4	0.13	-	0.26
5	0.13	-0.03	0.44
6	-0.32	0.07	-0.52
7	0.13	-0.19	0.00
8	0.13	-0.10	-

14.13.4.5.3 For this set of data, $n = 22$

$$\bar{X} = \frac{1}{22} (0.000) = 0.000$$

$$D = 1.4412$$

14.13.4.5.4 Order the centered observations from smallest to largest:

$$X^{(1)} \leq X^{(2)} \leq \dots \leq X^{(n)}$$

where $X^{(i)}$ denotes the i th ordered observation. The ordered observations for this example are listed in Table 23.

14.13.4.5.5 From Table 4, Appendix B, for the number of observations, n , obtain the coefficients a_1, a_2, \dots, a_k where k is $n/2$ if n is even and $(n-1)/2$ if n is odd. For the data in this example, $n = 22$ and $k = 11$. The a_i values are listed in Table 24.

14.13.4.5.6 Compute the test statistic, W , as follows:

$$W = \frac{1}{D} \left[\sum_{i=1}^k a_i (X^{(n-i+1)} - X^{(i)}) \right]^2$$

The differences $X^{(n-i+1)} - X^{(i)}$ are listed in Table 24. For the data in this example:

$$W = \frac{1}{1.4412} (1.1389)^2 = 0.900$$

TABLE 23. ORDERED CENTERED OBSERVATIONS FOR SHAPIRO-WILK'S EXAMPLE

i	$\chi^{(i)}$	i	$\chi^{(i)}$
1	-0.52	12	0.09
2	-0.52	13	0.13
3	-0.48	14	0.13
4	-0.32	15	0.13
5	-0.19	16	0.13
6	-0.10	17	0.13
7	-0.10	18	0.13
8	0.03	19	0.25
9	0.00	20	0.26
10	0.07	21	0.26
11	0.07	22	0.44

TABLE 24. COEFFICIENTS AND DIFFERENCES FOR SHAPIRO-WILK'S EXAMPLE

i	a_i	$\chi^{(n-i+1)} - \chi^{(i)}$	
1	0.4590	0.96	$\chi^{(22)} - \chi^{(1)}$
2	0.3156	0.78	$\chi^{(21)} - \chi^{(2)}$
3	0.2571	0.74	$\chi^{(20)} - \chi^{(3)}$
4	0.2131	0.57	$\chi^{(19)} - \chi^{(4)}$
5	0.1764	0.32	$\chi^{(18)} - \chi^{(5)}$
6	0.1443	0.23	$\chi^{(17)} - \chi^{(6)}$
7	0.1150	0.23	$\chi^{(16)} - \chi^{(7)}$
8	0.0878	0.16	$\chi^{(15)} - \chi^{(8)}$
9	0.0618	0.13	$\chi^{(14)} - \chi^{(9)}$
10	0.0368	0.06	$\chi^{(13)} - \chi^{(10)}$
11	0.0122	0.02	$\chi^{(12)} - \chi^{(11)}$

14.13.4.5.7 The decision rule for this test is to compare W as calculated in Subsection 14.13.4.5.6 to a critical value found in Table 6, Appendix B. If the computed W is less than the critical value, conclude that the data are not normally distributed. For this set of data, the critical value at a significance level of 0.01 and n = 22 observations is 0.878. Since W = 0.900 is greater than the critical value, conclude that the data are normally distributed.

14.13.4.6 Test for Homogeneity of Variance

14.13.4.6.1 The test used to examine whether the variation in proportion of female mysids with eggs is the same across all concentration levels including the control, is Bartlett's Test (Snedecor and Cochran, 1980). The test statistic is as follows:

$$B = \frac{[(\sum_{i=1}^p V_i) \ln \bar{S}^2 - \sum_{i=1}^p V_i \ln S_i^2]}{C}$$

Where: V_i = degrees of freedom for each copper concentration and control, $V_i = (n_i - 1)$

p = number of concentration levels including the control

\ln = \log_e

i = 1, 2, ..., p where p is the number of concentrations including the control

n_i = the number of replicates for concentration i .

$$\bar{S}^2 = \frac{(\sum_{i=1}^p V_i S_i^2)}{\sum_{i=1}^p V_i}$$

$$C = 1 + [3(p-1)]^{-1} [\sum_{i=1}^p 1/V_i - (\sum_{i=1}^p V_i)^{-1}]$$

14.13.4.6.2 For the data in this example (see Table 21), $n_1 = 8$, $n_2 = 7$ and $n_3 = 7$. Thus, the respective degrees of freedom are 7, 6 and 6.

14.13.4.6.3 Bartlett's statistic is therefore:

$$\begin{aligned} B &= [(19)\ln(0.077) - (7 \ln(0.064) + 6 \ln(0.021) + 6 \ln(0.147))]/1.07 \\ &= [19(-2.564) - (-53.925)]/1.07 \\ &= [-48.716 - (-53.925)]/1.07 \\ &= 4.868 \end{aligned}$$

14.13.4.6.4 B is approximately distributed as chi-square with p - 1 degrees of freedom, when the variances are in fact the same. Therefore, the appropriate critical value for this test, at a significance level of 0.01 with two degrees of freedom, is 9.210. Since B = 4.868 is less than the critical value of 9.210, conclude that the variances are not different.

14.13.4.7 T test with the Bonferroni Adjustment

14.13.4.7.1 A t test with the Bonferroni adjustment is used as an alternative to Dunnett's Procedure when, as in this set of data, the number of replicates is not the same for all concentrations. Like Dunnett's Procedure, it uses a pooled estimate of the variance, which is equal to the error value calculated in an analysis of variance. To obtain an estimate of the pooled variance, construct an ANOVA table as described in Table 25.

TABLE 25. ANOVA TABLE

Source	df	Sum of Squares (SS)	Mean Square (MS) (SS/df)
Between	p - 1	SSB	$S_B^2 = SSB/(p-1)$
Within	N - p	SSW	$S_W^2 = SSW/(N-p)$
Total	N - 1	SST	

Where: p = number concentration levels including the control

N = total number of observations $n_1 + n_2 \dots + n_p$

n_i = number of observations in concentration i

$$SSB = \sum_{i=1}^p T_i^2/n_i - G^2/N \quad \text{Between Sum of Squares}$$

$$SST = \sum_{i=1}^p \sum_{j=1}^{n_i} Y_{ij}^2 - G^2/N \quad \text{Total Sum of Squares}$$

$$SSW = SST - SSB \quad \text{Within Sum of Squares}$$

G = the grand total of all sample observations, $G = \sum_{i=1}^p T_i$

T_i = the total of the replicate measurements for concentration i

Y_{ij} = the j th observation for concentration i (represents the proportion of females with eggs for concentration i in test chamber j)

14.13.4.7.2 For the data in this example:

$$n_1 = 8 \quad n_2 = 7 \quad n_3 = 7$$

$$N = 22$$

$$T_1 = Y_{11} + Y_{12} + \dots + Y_{18} = 11.5$$

$$T_2 = Y_{21} + Y_{22} + \dots + Y_{27} = 4.94$$

$$T_3 = Y_{31} + Y_{32} + \dots + Y_{37} = 3.65$$

$$G = T_1 + T_2 + T_3 = 20.09$$

$$\begin{aligned} SSB &= \sum_{i=1}^p T_i^2/n_i - G^2/N \\ &= \frac{132.25}{8} + \frac{24.40}{7} + \frac{13.32}{7} - \frac{403.61}{22} = 3.57 \end{aligned}$$

$$\begin{aligned} SST &= \sum_{i=1}^p \sum_{j=1}^{n_i} Y_{ij}^2 - G^2/N \\ &= 23.396 - \frac{403.61}{22} = 5.05 \end{aligned}$$

$$SSW = SST - SSB = 5.05 - 3.57 = 1.48$$

$$S_B^2 = SSB/(p-1) = 3.57/(3-1) = 1.785$$

$$S_W^2 = SSW/(N-p) = 1.48/(22-3) = 0.078$$

14.13.4.7.3 Summarize these calculations in the ANOVA table (Table 26).

TABLE 26. ANOVA TABLE FOR THE T TEST WITH BONFERRONI'S ADJUSTMENT EXAMPLE

Source	df	Sum of Squares (SS)	Mean Square(MS) (SS/df)
Between	2	3.57	1.785
Within	19	1.48	0.078
Total	21	5.05	

14.13.4.7.4 To perform the individual comparisons, calculate the t statistic for each concentration, and control combination as follows:

$$t_i = \frac{(\bar{Y}_1 - \bar{Y}_i)}{S_w \sqrt{(1/n_1) + (1/n_i)}}$$

Where: \bar{Y}_i = mean proportion of females with eggs for concentration i

\bar{Y}_1 = mean proportion of females with eggs for the control

S_w = square root of the within mean square

n_1 = number of replicates for the control

n_i = number of replicates for concentration i.

14.13.4.7.5 Table 27 includes the calculated t values for each concentration and control combination. In this example, comparing the 50.0 ppb concentration with the control the calculation is as follows:

$$t_2 = \frac{(1.44 - 0.52)}{[0.279 \sqrt{(1/8) - (1/7)}]}$$

$$= 5.05$$

TABLE 27. CALCULATED T VALUES

Test Concentration (ppb)	1	t_i
50.0	2	5.05
100.0	3	6.37

14.13.4.7.6 Since the purpose of this test is to detect a significant reduction in mean proportion of females with eggs, a one-sided test is appropriate. The critical value for this one-sided test is found in Table 5, Appendix D, Critical Values for the t test with Bonferroni's adjustment. For an overall alpha level of 0.05, 19 degrees of freedom for error and two concentrations (excluding the control) the approximate critical value is 2.094. The mean proportion for concentration "i" is considered significantly less than the mean proportion for the control if t_i is greater than the critical value. Therefore, the 50.0 ppb and the 100.0 ppb concentrations have significantly lower mean proportion of females with eggs than the control. Hence the LOEC for fecundity is 50.0 ppb.

14.13.4.7.7 To quantify the sensitivity of the test, the minimum significant difference (MSD) that can be detected statistically may be calculated.

$$MSD = t S_w \sqrt{(1/n_1) + (1/n)}$$

Where: t = the critical value for the t test with Bonferroni's adjustment

S_w = the square root of the within mean square

n = the common number of replicates at each concentration
(this assumes equal replication at each concentration)

n_1 = the number of replicates in the control.

14.13.4.7.8 In this example:

$$\begin{aligned} MSD &= 2.094 (0.279) \sqrt{(1/8) + (1/7)} \\ &= 2.094 (0.279) (0.518) \\ &= 0.303 \end{aligned}$$

14.13.4.7.9 Therefore, for this set of data, the minimum difference that can be detected as statistically significant is 0.30.

14.13.4.7.10 The MSD (0.30) is in transformed units. To determine the MSD in terms of percent of females with eggs, carry out the following conversion.

1. Subtract the MSD from the transformed control mean.

$$1.44 - 0.30 = 1.14$$

2. Obtain the untransformed values for the control mean and the difference calculated in 4.10.1.

$$[\text{Sine} (1.44)]^2 = 0.983$$

$$[\text{Sine} (1.14)]^2 = 0.823$$

3. The untransformed MSD (MSD_u) is determined by subtracting the untransformed values from 14.4.8.10.2.

$$\text{MSD}_u = 0.983 - 0.823 = 0.16$$

14.13.4.7.11 Therefore, for this set of data, the minimum difference in mean proportion of females with eggs between the control and any copper concentration that can be detected as statistically significant is 0.16.

14.13.4.7.12 This represents a 17% decrease in proportion of females with eggs from the control.

14.13.4.8 Calculation of the ICp

14.13.4.8.1 The fecundity data in Table 4 are utilized in this example. Table 28 contains the mean proportion of females with eggs for each toxicant concentration. As can be seen, the observed means are monotonically nonincreasing with respect to concentration. Therefore, it is not necessary to smooth the means prior to calculating the IC. Figure 20 gives a plot of the response curve.

TABLE 28. MYSID, *MYSIDOPSIS BAHIA*, MEAN PROPORTION OF FEMALES WITH EGGS

Toxicant Conc. (ppb)	i	Response Means, Y^i (proportion)	Smoothed Means, M_i (proportion)
Control	1	0.934	0.934
50.0	2	0.426	0.426
100.0	3	0.317	0.317
210.0	4	0.000	0.000
450.0	5	0.010	0.000

14.13.4.8.2 An IC25 and IC50 can be estimated using the Linear Interpolation Method. A 25% reduction in mean proportion of females with eggs, compared to

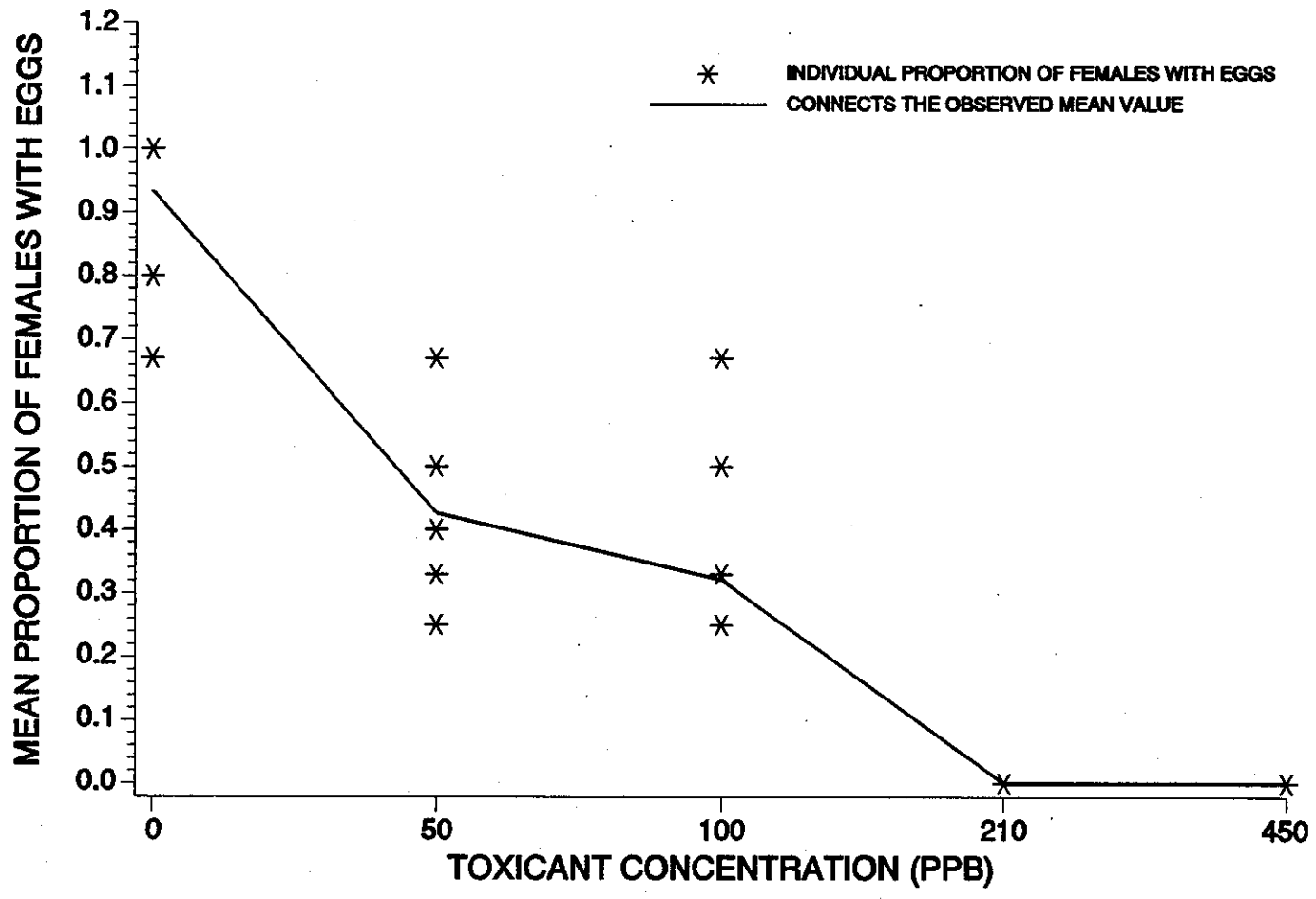

Figure 20. Plot of the mean proportion of female mysids, *Mysidopsis bahia*, with eggs.

the controls, would result in a mean proportion of 0.701, where $M_1(1-p/100) = 0.934(1-25/100)$. A 50% reduction in mean proportion of females with eggs, compared to the controls, would result in a mean proportion of 0.467. Examining the means and their associated concentrations (Table 28), the response, 0.701, is bracketed by $C_1 = 0$ ppb and $C_2 = 50$ ppb. The response, 0.467, is bracketed by $C_1 = 0$ ppb and $C_2 = 50$ ppb.

14.13.4.8.3 Using the equation in Section 4.2 from Appendix L, the estimate of the IC25 is calculated as follows:

$$IC_p = C_j + [M_1(1-p/100) - M_j] \frac{(C_{(j+1)} - C_j)}{(M_{(j+1)} - M_j)}$$

$$IC_{25} = 0 + [0.934(1 - 25/100) - 0.934] \frac{(50 - 0)}{(0.426 - 0.934)}$$

$$= 23 \text{ ppb.}$$

14.13.4.8.4 Using the equation in Section 4.2 from Appendix L, the estimate of the IC50 is calculated as follows:

$$IC_p = C_j + [M_1(1-p/100) - M_j] \frac{(C_{(j+1)} - C_j)}{(M_{(j+1)} - M_j)}$$

$$IC_{50} = 0 + [0.934(1 - 50/100) - 0.934] \frac{(50 - 0)}{(0.426 - 0.934)}$$

$$= 46 \text{ ppb.}$$

14.13.4.8.5 When the ICPIN program was used to analyze this set of data, requesting 80 resamples, the estimate of the IC25 was 22.9745 ppb. The empirical 95.0% confidence interval for the true mean was 20.0499 ppb to 30.5675 ppb. The computer program output for the IC25 for this data set is shown in Figure 21. This value is extrapolated below the lowest test concentration and data should be used cautiously.

14.13.4.8.6 When the ICPIN program was used to analyze this set of data for the IC50, requesting 80 resamples, the estimate of the IC50 was 45.9490 ppb. The empirical 95.0% confidence interval for the true mean was 40.1467 ppb to 63.0931 ppb. The computer program output for the IC50 for this data set is shown in Figure 22.

Conc. ID	1	2	3	4
Conc. Tested	0	50	100	210
Response 1	1	.5	.3	0
Response 2	1	.33	.5	0
Response 3	.67	.67	0	0
Response 4	1	.4	.5	0
Response 5	1	.5	.67	0
Response 6	.8	.25	0	0
Response 7	1	.33	.25	0
Response 8	1			0

*** Inhibition Concentration Percentage Estimate ***

Toxicant/Effluent:

Test Start Date: Test Ending Date:

Test Species: MYSID SHRIMP, Mysidopsis bahia

Test Duration: fecundity

DATA FILE: mysidfe.icp

OUTPUT FILE: mysidfe.i25

Conc. ID	Number Replicates	Concentration ug/l	Response Means	Std. Dev.	Pooled Response Means
1	8	0.000	0.934	0.127	0.934
2	7	50.000	0.426	0.142	0.426
3	7	100.000	0.317	0.257	0.317
4	8	210.000	0.000	0.000	0.000

The Linear Interpolation Estimate: 22.9745 Entered P Value: 25

Number of Resamplings: 80

The Bootstrap Estimates Mean: 23.8871 Standard Deviation: 3.0663

Original Confidence Limits: Lower: 20.0499 Upper: 30.5765

Resampling time in Seconds: 1.37 Random Seed: 1918482350

Figure 21. ICPIN program output for the IC25.

Conc. ID	1	2	3	4
Conc. Tested	0	50	100	210
Response 1	1	.5	.3	0
Response 2	1	.33	.5	0
Response 3	.67	.67	0	0
Response 4	1	.4	.5	0
Response 5	1	.5	.67	0
Response 6	.8	.25	0	0
Response 7	1	.33	.25	0
Response 8	1			0

*** Inhibition Concentration Percentage Estimate ***

Toxicant/Effluent:

Test Start Date: Test Ending Date:

Test Species: MYSID SHRIMP, Mysidopsis bahia

Test Duration: fecundity

DATA FILE: mysidfe.icp

OUTPUT FILE: mysidfe.i50

Conc. ID	Number Replicates	Concentration ug/l	Response Means	Std. Dev.	Pooled Response Means
1	8	0.000	0.934	0.127	0.934
2	7	50.000	0.426	0.142	0.426
3	7	100.000	0.317	0.257	0.317
4	8	210.000	0.000	0.000	0.000

The Linear Interpolation Estimate: 45.9490 Entered P Value: 50

Number of Resamplings: 80

The Bootstrap Estimates Mean: 47.8720 Standard Deviation: 8.2908

Original Confidence Limits: Lower: 40.1467 Upper: 63.0931

Resampling time in Seconds: 1.32 Random Seed: -391064242

Figure 22. ICPIN program output for the IC50.

14.14 PRECISION AND ACCURACY

14.14.1 PRECISION

14.14.1.1 Single-Laboratory Precision

14.14.1.1.1 Data on the single-laboratory precision of the mysid survival, growth, and fecundity using copper (Cu) sulfate and sodium dodecyl sulfate (SDS) in natural seawater and in artificial seawater (GP2) are shown in Tables 29-33. Survival NOEC/LOEC pairs showed good precision, and were the same in four of the six tests with Cu and SDS. Growth and fecundity were generally not acceptable endpoints in either sets of tests. In Tables 29-30 the coefficient of variation for the IC25, ranges from 18.0 to 35.0 and the IC50, ranges from 5.8 to 47.8, indicating acceptable test precision. Data in Tables 31-33 show no detectable differences between tests conducted in natural or artificial seawaters.

14.14.1.2 Multilaboratory Precision

14.14.1.2.1 The multilaboratory precision of the test has not yet been determined.

14.14.2 ACCURACY

14.14.2.1 The accuracy of toxicity tests cannot be determined.

TABLE 29. SINGLE-LABORATORY PRECISION OF THE MYSID, *MYSIDOPSIS BAHIA*, SURVIVAL, GROWTH, AND FECUNDITY TEST PERFORMED IN NATURAL SEAWATER, USING JUVENILES FROM MYSIDS CULTURED AND SPAWNED IN NATURAL SEAWATER, AND COPPER (CU) SULFATE AS A REFERENCE TOXICANT^{1,2,3,4,5,6}

Test Number	NOEC (µg/L)	IC25 (µg/L)	IC50 (µg/L)	Most Sensitive Endpoint ⁷
1	63	96.1	NC ⁸	S
2	125	138.3	175.5	S
3	125	156.3	187.5	S
4	125	143.0	179.9	S
5	125	157.7	200.3	S
n:	5	5	4	
Mean:	NA	138.3	185.8	
CV(%):	NA	18.0	5.8	

- ¹ Data from USEPA (1988a) and USEPA (1991a).
² Tests performed by Randy Cameleo, ERL-N, USEPA, Narragansett, RI.
³ Eight replicate exposure chambers, each with five juveniles, were used for the control and each toxicant concentration. The temperature of the test solutions was maintained at 26 ± 1°C.
⁴ Copper concentrations in Tests 1-2 were: 8, 16, 31, 63, and 125 µg/L. Copper concentrations in Tests 3-6 were, 16, 31, 63, 125, and 250 µg/L.
⁵ NOEC Range: 63 - 125 µg/L (this represents a difference of two exposure concentrations).
⁶ For a discussion of the precision of data from chronic toxicity tests see Section 4, Quality Assurance.
⁷ Endpoints: G=Growth; S=Survival.
⁸ NC = No linear interpolation estimate could be calculated from the data, since none of the group response means were less than 50 percent of the control concentrations.

TABLE 30. SINGLE-LABORATORY PRECISION OF THE MYSID, *MYSIDOPSIS BAHIA*, SURVIVAL, GROWTH, AND FECUNDITY TEST PERFORMED IN NATURAL SEAWATER USING JUVENILES FROM MYSIDS CULTURED AND SPAWNED IN NATURAL SEAWATER, AND SODIUM DODECYL SULFATE (SDS) AS A REFERENCE TOXICANT^{1,2,3,4,5,6}

Test Number	NOEC (mg/L)	IC25 (mg/L)	IC50 (mg/L)	Most Sensitive Endpoint ⁷
1	2.5	4.5	NC ⁹	S
2	< 0.3	NC ⁸	NC ⁹	S
3	< 0.6	NC ⁸	NC ⁹	S
4	5.0	7.8	NC ⁹	S
5	2.5	3.6	4.6	S
6	5.0	7.0	9.3	S
n:	4	4	2	
Mean:	NA	5.7	6.9	
CV(%):	NA	35.0	47.8	

- ¹ Data from USEPA (1988a) and USEPA (1991a).
- ² Tests performed by Randy Cameleo, ERL-N, USEPA, Narragansett, RI.
- ³ Eight replicate exposure chambers, each with five juveniles, were used for the control and each toxicant concentration. The temperature of the test solutions was maintained at 26 ± 1°C.
- ⁴ SDS concentrations in Tests 1-2 were: 0.3, 0.6, 1.3, 2.5, and 5.0 mg/L. SDS concentrations in Tests 3-4 were: 0.6, 1.3, 2.5, 5.0 and 10.0 mg/L. SDS concentrations in Tests 5-6 were: 1.3, 2.5, 5.0, 10.0, and 20.0 mg/L.
- ⁵ NOEC Range: < 0.3 - 5.0 mg/L (this represents a difference of four exposure concentrations).
- ⁶ For a discussion of the precision of data from chronic toxicity tests see Section 4, Quality Assurance.
- ⁷ Endpoints: G=Growth; S=Survival.
- ⁸ NC = No linear interpolation estimate could be calculated from the data, since none of the group response means were less than 75 percent of the control response mean.
- ⁹ NC = No linear interpolation estimate could be calculated from the data, since none of the group response means were less than 50 percent of the control response mean.

TABLE 31. COMPARISON OF SURVIVAL (LC50)¹, GROWTH AND FECUNDITY (IC50)¹ RESULTS FROM 7-DAY TESTS WITH THE MYSID, *MYSIDOPSIS BAHIA*, USING NATURAL SEAWATER (NSW) AND ARTIFICIAL SEAWATER (GP2) AS DILUTION WATER AND SODIUM DODECYL SULFATE (SDS) AS A REFERENCE TOXICANT

Test	Survival LC50		Growth IC50		Fecundity IC50	
	NSW	GP2	NSW	GP2	NSW	GP2
1	16.2	16.3	16.8	16.3	12.0	10.9
2	20.5	19.2	24.2	23.3	20.1	18.5
3	-- ²	21.9	-- ²	24.4	-- ²	21.7

¹ All LC50/IC50 values in mg/L.

² No test performed.

TABLE 32. COMPARISON OF SURVIVAL (LC50)¹, GROWTH AND FECUNDITY (IC50)¹ RESULTS FROM 7-DAY TESTS WITH THE MYSID, *MYSIDOPSIS BAHIA*, USING NATURAL SEAWATER (NSW) AND ARTIFICIAL SEAWATER (GP2) AS DILUTION WATER AND COPPER (CU) SULFATE AS A REFERENCE TOXICANT

Test GP2	Survival LC50		Growth IC50		Fecundity IC50
	NSW	GP2	NSW	GP2	NSW
1 125	177	182	208	186	177
2 142	-- ²	173	-- ²	210	-- ²
3 186	190	174	195	179	168

¹ All LC50/IC50 values in $\mu\text{g/L}$.

² No test performed.

TABLE 33. CONTROL RESULTS FROM 7-DAY SURVIVAL, GROWTH, AND FECUNDITY TESTS WITH THE MYSID, *MYSIDOPSIS BAHIA*, USING NATURAL SEAWATER AND ARTIFICIAL SEAWATER (GP2) AS A DILUTION WATER

Test	Control ¹					
	Survival (%)		Growth (mg)		Fecundity (%)	
	NSW	GP2	NSW	GP2	NSW	GP2
1	98	93	0.32	0.32	73	77
2	80	90	0.40	0.43	100	95
3	-- ²	95	-- ²	0.40	-- ²	100
4	94	84	0.34	0.37	89	83
5	-- ²	94	-- ²	0.36	-- ²	83
6	80	75	0.40	0.41	79	93

¹ Survival as percent of mysids alive after 7 days; growth as mean individual dry weight; fecundity as percent females with eggs.

² No test performed.

SECTION 15

TEST METHOD

SEA URCHIN, *ARBACIA PUNCTULATA*, FERTILIZATION TEST METHOD 1008.0

15.1 SCOPE AND APPLICATION

15.1.1 This method, adapted in part from USEPA (1987e), measures the toxicity of effluents and receiving water to the gametes of the sea urchin, *Arbacia punctulata*, during a 1 h and 20 min exposure. The purpose of the sperm cell toxicity test is to determine the concentration of a test substance that reduces fertilization of exposed gametes relative to that of the control.

15.1.2 Detection limits of the toxicity of an effluent or chemical substance are organism dependent.

15.1.3 Brief excursions in toxicity may not be detected using 24-h composite samples. Also, because of the long sample collection period involved in composite sampling and because the test chambers are not sealed, highly volatile and highly degradable toxicants in the source may not be detected in the test.

15.1.4 This test is commonly used in one of two forms: (1) a definitive test, consisting of a minimum of five effluent concentrations and a control, and (2) a receiving water test(s), consisting of one or more receiving water concentrations and a control.

15.2 SUMMARY OF METHOD

15.2.1 The method consists of exposing dilute sperm suspensions to effluents or receiving waters for 1 h. Eggs are then added to the sperm suspensions. Twenty minutes after the eggs are added, the test is terminated by the addition of preservative. The percent fertilization is determined by microscopic examination of an aliquot from each treatment. The test results are reported as the concentration of the test substance which causes a statistically significant reduction in fertilization.

15.3 INTERFERENCES

15.3.1 Toxic substances may be introduced by contaminants in dilution water, glassware, sample hardware, and testing equipment (see Section 5, Facilities, Equipment, and Supplies).

15.3.2 Improper effluent sampling and handling may adversely affect test results (see Section 8, Effluent and Receiving Water Sampling, Sample Handling, and Sample Preparation for Toxicity Tests).

15.4 SAFETY

15.4.1 See Section 3, Health and Safety.

15.5. APPARATUS AND EQUIPMENT

15.5.1 Facilities for holding and acclimating test organisms.

15.5.2 Laboratory sea urchins, *Arbacia punctulata*, culture unit -- See Subsection 6.17, culturing methods below and Section 4, Quality Assurance. To test effluent or receiving water toxicity, sufficient eggs and sperm must be available.

15.5.3 Samplers -- automatic sampler, preferably with sample cooling capability, that can collect a 24-h composite sample of 5 L.

15.5.4 Environmental chamber or equivalent facility with temperature control ($20 \pm 1^\circ\text{C}$).

15.5.5 Water purification system -- Millipore Milli-Q®, deionized water (DI) or equivalent.

15.5.6 Balance -- Analytical, capable of accurately weighing to 0.00001 g.

15.5.7 Reference weights, Class S -- for checking performance of balance. Weights should bracket the expected weights of materials to be weighed.

15.5.8 Air pump -- for oil-free air supply.

15.5.9 Air lines, and air stones -- for aerating water containing adults, or for supplying air to test solutions with low DO.

15.5.10 Vacuum suction device -- for washing eggs.

15.5.11 Meters, pH and DO -- for routine physical and chemical measurements.

15.5.12 Standard or micro-Winkler apparatus -- for determining DO (optional).

15.5.13 Transformer, 10-12 Volt, with steel electrodes -- for stimulating release of eggs and sperm.

15.5.14 Centrifuge, bench-top, slant-head, variable speed -- for washing eggs.

15.5.15 Fume hood -- to protect the analyst from formaldehyde fumes.

15.5.16 Dissecting microscope -- for counting diluted egg stock.

15.5.17 Compound microscope -- for examining and counting sperm cells and fertilized eggs.

- 15.5.18 Sedgwick-Rafter counting chamber -- for counting egg stock and examining fertilized eggs.
- 15.5.19 Hemacytometer, Neubauer -- for counting sperm.
- 15.5.20 Count register, 2-place -- for recording sperm and egg counts.
- 15.5.21 Refractometer -- for determining salinity.
- 15.5.22 Thermometers, glass or electronic, laboratory grade -- for measuring water temperatures.
- 15.5.23 Thermometers, bulb-thermograph or electronic-chart type -- for continuously recording temperature.
- 15.5.24 Thermometer, National Bureau of Standards Certified (see USEPA Method 170.1, USEPA, 1979b) -- to calibrate laboratory thermometers.
- 15.5.25 Ice bucket, covered -- for maintaining live sperm.
- 15.5.26 Centrifuge tubes, conical -- for washing eggs.
- 15.5.27 Cylindrical glass vessel, 8-cm diameter -- for maintaining dispersed egg suspension.
- 15.5.28 Beakers -- six Class A, borosilicate glass or non-toxic plasticware, 1000 mL for making test solutions.
- 15.5.29 Glass dishes, flat bottomed, 20-cm diameter -- for holding urchins during gamete collection.
- 15.5.30 Wash bottles -- for deionized water, for rinsing small glassware and instrument electrodes and probes.
- 15.5.31 Volumetric flasks and graduated cylinders -- Class A, borosilicate glass or non-toxic plastic labware, 10-1000 mL for making test solutions.
- 15.5.32 Syringes, 1-mL, and 10-mL, with 18 gauge, blunt-tipped needles (tips cut off) -- for collecting sperm and eggs.
- 15.5.33 Pipets, volumetric -- Class A, 1-100 mL.
- 15.5.34 Pipets, automatic -- adjustable 1-100 mL.
- 15.5.35 Pipets, serological -- 1-10 mL, graduated.
- 15.6.36 Pipet bulbs and fillers -- PROPIPET®, or equivalent.
- 15.6 REAGENTS AND CONSUMABLE MATERIALS**
- 15.6.1 Sea Urchins, *Arbacia punctulata* minimum 12 of each sex.

- 15.6.2 Food -- kelp, *Laminaria* sp., or romaine lettuce for the sea urchin, *Arbacia punctulata*.
- 15.6.3 Standard salt water aquarium or Instant Ocean Aquarium (capable of maintaining seawater at 15°C) -- with appropriate filtration and aeration system.
- 15.6.4 Sample containers -- for sample shipment and storage (see Section 8, Effluent and Receiving Water Sampling, Sample Handling, and Sample Preparation for Toxicity Tests).
- 15.6.5 Scintillation vials, 20 mL, disposable -- to prepare test concentrations.
- 15.6.6 Tape, colored -- for labelling tubes.
- 15.6.7 Markers, waterproof -- for marking containers, etc.
- 15.6.8 Parafilm -- to cover tubes and vessels containing test materials.
- 15.6.9 Gloves, disposable; labcoat and protective eyewear -- for personal protection from contamination.
- 15.6.10 Data sheets (one set per test) -- for data recording (see Figures 1, 2, and 3).
- 15.6.11 Acetic acid, 10%, reagent grade, in seawater -- for preparing killed sperm dilutions.
- 15.6.12 Formalin, 1%, in 2 mL of seawater -- for preserving eggs (see Subsection 10.7 Termination of the Test).
- 15.6.13 Buffers, pH 4, pH 7, and pH 10 (or as per instructions of instrument manufacturer) -- for standards and calibration check (see USEPA Method 150.1, USEPA, 1979b).
- 15.6.14 Membranes and filling solutions for dissolved oxygen probe (see USEPA Method 360.1, USEPA, 1979b), or reagents -- for modified Winkler analysis.
- 15.6.15 Laboratory quality assurance samples and standards -- for the above methods.
- 15.6.16 Reference toxicant solutions -- see Section 4, Quality Assurance.
- 15.6.17 Reagent water -- defined as distilled or deionized water that does not contain substances which are toxic to the test organisms.
- 15.6.18 Effluent, receiving water, and dilution water -- see Section 7, Dilution Water, and Section 8, Effluent and Receiving Water Sampling, Sample Handling, and Sample Preparation for Toxicity Tests.

TEST DATE: _____

SAMPLE: _____

COMPLEX EFFLUENT SAMPLE: _____

COLLECTION DATE: _____

SALINITY/ADJUSTMENT: _____

PH/ADJUSTMENT REQUIRED: _____

PHYSICAL CHARACTERISTICS: _____

STORAGE: _____

COMMENTS: _____

SINGLE COMPOUND: _____

SOLVENT (CONC): _____

TEST CONCENTRATIONS: _____

DILUTION WATER: _____

CONTROL WATER: _____

TEST TEMPERATURE: _____

TEST SALINITY: _____

COMMENTS: _____

Figure 1. Data form for (1) fertilization test using sea urchin, *Arbacia punctulata*.

TEST DATE: _____

SAMPLE: _____

SPERM DILUTIONS:

HEMACYTOMETER COUNT, E: _____ $\times 10^4$ = SPM SOLUTION E = _____

SPERM CONCENTRATIONS: SOLUTION E $\times 40$ = SOLUTION A = _____ SPM
SOLUTION E $\times 20$ = SOLUTION B = _____ SPM
SOLUTION E $\times 5$ = SOLUTION D = _____ SPM

SOLUTION SELECTED FOR TEST (_____ = 5×10^7 SPM):

DILUTION: $\frac{\text{SPM}/(5 \times 10^7)}{[(\text{DF}) \times 10] - 10}$ = _____ DF + SW, mL

FINAL SPERM COUNTS = _____

EGG DILUTIONS:

ORIGINAL EGG STOCK CONCENTRATION = $10 \times$ (INITIAL EGG COUNT) = _____
INITIAL EGG COUNT = _____
VOLUME OF SW TO ADD TO DILUTE EGG STOCK TO 2000/mL: (EGG COUNT) - 200 = _____
CONTROL WATER TO ADD EGG STOCK, mL = _____
FINAL EGG COUNT = _____

TEST TIMES:

SPERM COLLECTED: _____

EGGS COLLECTED: _____

SPERM ADDED: _____

EGGS ADDED: _____

FIXATIVE ADDED: _____

SAMPLES READ: _____

Figure 2. Data form (2) for fertilization test using sea urchin, *Arbacia punctulata*.

DATE TESTED: _____

SAMPLE: _____

TOTAL AND UNFERTILIZED EGG COUNT AT END OF TEST:

EFFLUENT CONC (%)	REPLICATE VIAL			
	1	2	3	4
	TOTAL-UNFERT	TOTAL-UNFERT	TOTAL-UNFERT	TOTAL-UNFERT

STATISTICAL ANALYSIS:

ANALYSIS OF VARIANCE: _____

CONTROL: _____

DIFFERENT FROM CONTROL (P): _____

COMMENTS: _____

Figure 3. Data form (3) for fertilization test using sea urchin, *Arbacia punctulata*.

15.6.18.1 Saline test and dilution water -- the salinity of the test water must be 30‰. The salinity should vary by no more than $\pm 2\%$ among the replicates. If effluent and receiving water tests are conducted concurrently, the salinities of these tests should be similar.

15.6.18.2 The overwhelming majority of industrial and sewage treatment effluents entering marine and estuarine systems contain little or no measurable salts. Exposure of sea urchin eggs and sperm to these effluents will require adjustments in the salinity of the test solutions. It is important to maintain a constant salinity across all treatments. In addition it may be desirable to match the test salinity with that of the receiving water. Two methods are available to adjust salinities -- hypersaline brine (HSB) derived from natural seawater or artificial sea salts.

15.6.18.3 Hypersaline brine (HSB): HSB has several advantages that make it desirable for use in toxicity testing. It can be made from any high quality, filtered seawater by evaporation, and can be added to the effluent or to deionized water to increase the salinity. HSB derived from natural seawater contains the necessary trace metals, biogenic colloids, and some of the microbial components necessary for adequate growth, survival, and/or reproduction of marine and estuarine organisms, and may be stored for prolonged periods without any apparent degradation. However, if 100‰ HSB is used as a diluent, the maximum concentration of effluent that can be tested will be 80% at 20‰ salinity and 70% at 30‰ salinity.

15.6.18.3.1 The ideal container for making HSB from natural seawater is one that (1) has a high surface to volume ratio, (2) is made of a noncorrosive material, and (3) is easily cleaned (fiberglass containers are ideal). Special care should be used to prevent any toxic materials from coming in contact with the seawater being used to generate the brine. If a heater is immersed directly into the seawater, ensure that the heater materials do not corrode or leach any substances that would contaminate the brine. One successful method used is a thermostatically controlled heat exchanger made from fiberglass. If aeration is utilized, use only oil-free air compressors to prevent contamination.

15.6.18.3.2 Before adding seawater to the brine generator, thoroughly clean the generator, aeration supply tube, heater, and any other materials that will be in direct contact with the brine. A good quality biodegradable detergent should be used, followed by several (at least three) thorough deionized water rinses.

15.6.18.3.3 High quality (and preferably high salinity) seawater should be filtered to at least 10 μm before placing into the brine generator. Water should be collected on an incoming tide to minimize the possibility of contamination.

15.6.18.3.4 The temperature of the seawater is increased slowly to 40°C. The water should be aerated to prevent temperature stratification and to increase water evaporation. The brine should be checked daily (depending on the volume being generated) to ensure that the salinity does not exceed 100‰ and that

the temperature does not exceed 40°C. Additional seawater may be added to the brine to obtain the volume of brine required.

15.6.18.3.5 After the required salinity is attained, the HSB should be filtered a second time through a 1 μ m filter and poured directly into portable containers, (20 L cubitainers or polycarbonate water cooler jugs are suitable). The containers should be capped and labelled with the date the brine was generated and its salinity. Containers of HSB should be stored in the dark and maintained under room temperature until used.

15.6.18.3.6 If a source of HSB is available, test solutions can be made by following the directions below. Thoroughly mix together the deionized water and brine before mixing in the effluent.

15.6.18.3.7 Divide the salinity of the HSB by the expected test salinity to determine the proportion of deionized water to brine. For example, if the salinity of the brine is 100‰ and the test is to be conducted at 30‰, 100‰ divided by 30‰ = 3.3. The proportion of brine is 1 part in 3.3 (one part brine to 2.3 parts deionized water). To make 1 L of seawater at 30‰ salinity from a HSB of 100‰, 300 mL of brine and 700 mL of deionized water are required.

15.6.16.3.8 Table 1 illustrates the preparation of test solutions at 30‰ if they are made by combining effluent (0‰), deionized water and HSB (100‰), or FORTY FATHOMS® sea salts.

15.6.16.4 Artificial sea salts: FORTY FATHOMS® brand sea salts (Marine Enterprises, Inc., 8755 Mylander Lane, Baltimore, MD 21204; 301-3211189) have been used successfully at the EMSL-Cincinnati, for long-term (6-12 months) maintenance of stock cultures of sexually mature sea urchins and to perform the sea urchin fertilization test. GP2 seawater formulation (Table 2) has also been used successfully at ERL-Narragansett, RI.

15.6.16.4.1 Synthetic sea salts are packaged in plastic bags and mixed with deionized water or equivalent. The instructions on the package of sea salts should be followed carefully, and the salts should be mixed in a separate container -- not in the culture tank. The deionized water used in hydration should be in the temperature range of 21-26°C. Seawater made from artificial sea salts is conditioned (Spotte, 1973; Spotte, et al., 1984; Bower, 1983).

15.6.16.4.2 The GP2 reagent grade chemicals (Table 1) should be mixed with deionized (DI) water or its equivalent in a container other than the culture or testing tanks. The deionized water used for hydration should be between 21-26°C. The artificial seawater must be conditioned (aerated) for 24 h before use as the testing medium. If the solution is to be autoclaved, sodium bicarbonate is added after the solution has cooled. A stock solution of sodium bicarbonate is made up by dissolving 33.6 g NaHCO₃ in 500 mL of deionized water. Add 2.5 mL of this stock solution for each liter of the GP2 artificial seawater.

TABLE 1. PREPARATION OF TEST SOLUTIONS AT A SALINITY OF 30‰ USING NATURAL SEAWATER, HYPERSALINE BRINE, OR ARTIFICIAL SEA SALTS

Effluent Solution	Effluent Concentration (%)	Solutions To Be Combined	
		Volume of Effluent Solution (mL)	Volume of Diluent Seawater (30‰) (mL)
1	100 ¹	840	---
2	50	420	Solution 1 + 420
3	25	420	Solution 2 + 420
4	12.5	420	Solution 3 + 420
5	6.25	420	Solution 4 + 420
Control	0.0		420
Total			2080

¹ This illustration assumes: (1) the use of 5 mL of test solution in each of four replicates (total of 20 mL) for the control and five concentrations of effluent, (2) an effluent dilution factor of 0.5, (3) the effluent lacks appreciable salinity, and (4) 400 mL of each test concentration is used for chemical analysis. A sufficient initial volume (840 mL) of effluent is prepared by adjusting the salinity to 30‰. In this example, the salinity is adjusted by adding artificial sea salts to the 100% effluent, and preparing a serial dilution using 30‰ seawater (natural seawater, hypersaline brine, or artificial seawater). Stir solutions 1 h to ensure that the salts dissolve. The salinity of the initial 840 mL of 100% effluent is adjusted to 30‰ by adding 25.2 g of dry artificial sea salts (FORTY FATHOMS®). Test concentrations are then made by mixing appropriate volumes of salinity adjusted effluent and 30‰ salinity dilution water to provide 840 mL of solution for each concentration. If hypersaline brine alone (100‰) is used to adjust the salinity of the effluent, the highest concentration of effluent that could be tested would be 70% at 30‰ salinity.

TABLE 2. REAGENT GRADE CHEMICALS USED IN THE PREPARATION OF GP2 ARTIFICIAL SEAWATER FOR THE SEA URCHIN, *ARBACIA PUNCTULATA*, TOXICITY TEST^{1,2,3}

Compound	Concentration (g/L)	Amount (g) Required for 20 L
NaCl	21.03	420.6
Na ₂ SO ₄	3.52	70.4
KCl	0.61	12.2
KBr	0.088	1.76
Na ₂ B ₄ O ₇ · 10 H ₂ O	0.034	0.68
MgCl ₂ · 6 H ₂ O	9.50	190.0
CaCl ₂ · 2 H ₂ O	1.32	26.4
SrCl ₂ · 6 H ₂ O	0.02	0.400
NaHCO ₃	0.17	3.40

¹ Modified GP2 from Spotte et al. (1984).

² The constituent salts and concentrations were taken from USEPA (1990b). The salinity is 30.89 g/L.

³ GP2 can be diluted with deionized (DI) water to the desired test salinity.

15.6.17 TEST ORGANISMS, SEA URCHINS, *ARBACIA PUNCTULATA*

15.6.17.1 Adult sea urchins, *Arbacia punctulata*, can be obtained from commercial suppliers. After acquisition, the animals are sexed by briefly stimulating them with current from a 12 V transformer. Electrical stimulation causes the immediate release of masses of gametes that are readily identifiable by color -- the eggs are red, and the sperm are white.

15.6.17.2 The sexes are separated and maintained in 20-L, aerated fiberglass tanks, each holding about 20 adults. The tanks are supplied continuously (approximately 5 L/min) with filtered natural seawater, or salt water prepared from commercial sea salts is recirculated. The animals are checked daily and any obviously unhealthy animals are discarded.

15.6.17.3 The culture unit should be maintained at $15 \pm 3^{\circ}\text{C}$, with a water temperature control device.

15.6.17.4 The food consists of kelp, *Laminaria* sp., gathered from known uncontaminated zones or obtained from commercial supply houses whose kelp comes from known uncontaminated areas, or romaine lettuce. Fresh food is introduced into the tanks at approximately one week intervals. Decaying food is removed as necessary. Ample supplies of food should always be available to the sea urchins.

15.6.17.5 Natural or artificial seawater with a salinity of 30‰ is used to maintain the adult animals, for all washing and dilution steps, and as the control water in the tests (see Subsection 15.6.16).

15.6.17.6 Adult male and female animals used in field studies are transported in separate or partitioned insulated boxes or coolers packed with wet kelp or paper toweling. Upon arrival at the field site, aquaria (or a single partitioned aquarium) are filled with control water, loosely covered with a styrofoam sheet and allowed to equilibrate to 15°C before animals are added. Healthy animals will attach to the kelp or aquarium within hours.

15.6.17.7 To successfully maintain about 25 adult animals for 7 days at a field site, a screen-partitioned, 40-L glass aquarium using aerated, recirculating, clean saline water (30‰) and a gravel bed filtration system, is housed within a water bath, such as FORTY FATHOMS® or equivalent (15°C). The inner aquarium is used to avoid contact of animals and water bath with cooling coils.

15.7 EFFLUENT AND RECEIVING WATER COLLECTION, PRESERVATION, AND STORAGE

15.7.1 See Section 8, Effluent and Receiving Water Sampling, Sample Handling, and Sampling Preparation for Toxicity Tests.

15.8 CALIBRATION AND STANDARDIZATION

15.8.1 See Section 4, Quality Assurance.

15.9 QUALITY CONTROL

15.9.1 See Section 4, Quality Assurance.

15.10 TEST PROCEDURES

15.10.1 TEST SOLUTIONS

15.10.1.1 Receiving Waters

15.10.1.1.1 The sampling point is determined by the objectives of the test. At estuarine and marine sites, samples are usually collected at mid-depth. Receiving water toxicity is determined with samples used directly as collected or with samples passed through a $60\ \mu\text{m}$ NITEX® filter and compared without dilution against a control. Using four replicate chambers per test, each

containing 5 mL, and 400 mL for chemical analysis, would require approximately 420 mL or more of sample per test.

15.10.1.2 Effluents

15.10.1.2.1 The selection of the effluent test concentrations should be based on the objectives of the study. A dilution factor of 0.5 is commonly used. A dilution factor of 0.5 provides precision of $\pm 100\%$, and testing of concentrations between 6.25% and 100% effluent using only five effluent concentrations (6.25%, 12.5%, 25%, 50%, and 100%). Test precision shows little improvement as dilution factors are increased beyond 0.5 and declines rapidly if smaller dilution factors are used. **Therefore, USEPA recommends the use of the ≥ 0.5 dilution factor.** If 100‰ HSB is used as a diluent, the maximum concentration of effluent that can be tested will be 80% at 20‰ and 70% at 30‰ salinity.

15.10.1.2.2 If the effluent is known or suspected to be highly toxic, a lower range of effluent concentrations should be used (such as 25%, 12.5%, 6.25%, 3.12%, and 1.56%).

15.10.1.2.3 Just prior to test initiation (approximately 1 h), a sufficient quantity of the sample to make the test solutions should be adjusted to the test temperature ($20 \pm 1^\circ\text{C}$) and maintained at that temperature during the addition of dilution water.

15.10.1.2.4 The test should begin as soon as possible, preferably within 24 h of sample collection. The maximum holding time following retrieval of the sample from the sampling device should not exceed 36 h for off-site toxicity tests unless permission is granted by the permitting authority. In no case should the sample be used in a test more than 72 h after sample collection (see section 8 Effluent and Receiving Water Sampling, Sample Handling, and Sample Preparation for Toxicity Test).

15.10.1.2.5 Effluent dilutions should be prepared for all replicates in each treatment in one beaker to minimize variability among the replicates. The test chambers are labelled with the test concentration and replicate number. Dispense into the appropriate effluent dilution chamber.

15.10.1.3 Dilution Water

15.10.1.3.1 Dilution water may be uncontaminated natural seawater (receiving water), HSB prepared from natural seawater, or artificial seawater FORTY FATHOMS® or GP2 sea salts (see Table 2 and Section 7, Dilution Water). Prepare 3 L of control water at 30‰ using HSB or artificial sea salts (see Table 1). This water is used in all washing and diluting steps and as control water in the test. Natural seawater and local waters may be used as additional controls.

15.10.2 COLLECTION OF GAMETES FOR THE TEST

15.10.2.1 Select four females and place in shallow bowls, barely covering the shell with seawater. Stimulate the release of eggs by touching the shell with

steel electrodes connected to a 10-12 volt transformer (about 30 seconds each time). Collect the eggs from each female using a 10 mL disposable syringe fitted with an 18-gauge, blunt-tipped needle (tip cut off). Remove the needle from the syringe before adding the eggs to a conical centrifuge tube. Pool the eggs. The egg stock may be held at room temperature for several hours before use. Note: Eggs should be collected first to eliminate possibility of pre-fertilization.

15.10.2.2 Select four males and place in shallow bowls, barely covering the animals with seawater. Stimulate the release of sperm as described above. Collect the sperm (about 0.25 mL) from each male, using a 1-3 mL disposable syringe fitted with an 18-gauge, blunt-tipped needle. Pool the sperm. Maintain the pooled sperm sample on ice. The sperm must be used in a toxicity test within 1 h of collection.

15.10.3 PREPARATION OF SPERM DILUTION FOR USE IN THE TEST

15.10.3.1 Using control water, dilute the pooled sperm sample to a concentration of about 5×10^7 sperm/mL (SPM). Estimate the sperm concentration as described below:

1. Make a sperm dilutions of 1:50, 1:100, 1:200, and 1:400, using 30% seawater, as follows:
 - a. Add 400 μ L of collected sperm to 20 mL of seawater in Vial A. Mix by gentle pipetting using a 5-mL pipettor, or by inversion;
 - b. Add 10 mL of sperm suspension from Vial A to 10 mL of seawater in Vial B. Mix by gentle pipetting using a 5-mL pipettor, or by inversion;
 - c. Add 10 mL of sperm suspension from Vial B to 10 mL of seawater in Vial C. Mix by gentle pipetting using a 5-mL pipettor, or by inversion;
 - d. Add 10 mL of sperm suspension from Vial C to 10 mL of seawater in Vial D. Mix by gentle pipetting using a 5-mL pipettor, or by inversion;
 - e. Discard 10 mL from Vial D. (The volume of all suspensions is 10 mL).
2. Make a 1:2000 killed sperm suspension and determine the SPM.
 - a. Add 10 mL 10% acetic acid in seawater to Vial C. Cap Vial C and mix by inversion.
 - b. Add 1 mL of killed sperm from Vial C to 4 mL of seawater in Vial E. Mix by gentle pipetting with a 4-mL pipettor.
 - c. Add sperm from Vial E to both sides of the Neubauer hemacytometer. Let the sperm settle 15 min.
 - d. Count the number of sperm in the central 400 squares on both sides of the hemacytometer using a compound microscope (100X). Average the counts from the two sides.
 - e. SPM in Vial E = 10^4 x average count.
3. Calculate the SPM in all other suspensions using the SPM in Vial E above:

SPM in Vial A = 40 x SPM in Vial E
SPM in Vial B = 20 x SPM in Vial E
SPM in Vial D = 5 x SPM in Vial E
SPM in original sperm sample = 2000 x SPM in Vial E

4. Dilute the sperm suspension with a SPM greater than 5×10^7 SPM to 5×10^7 SPM.

Actual SPM/ (5×10^7) = dilution factor (DF)

$[(DF) \times 10] - 10$ = mL of seawater to add to vial.

5. Confirm the sperm count by sampling from the test stock. Add 0.1 mL of test stock to 9.9 mL of 10% acetic acid in seawater, and count with the hemacytometer. The count should average 50 ± 5 .

15.10.4 PREPARATION OF EGG SUSPENSION FOR USE IN THE TEST Note: The egg suspension may be prepared during the 1-h sperm exposure.

15.10.4.1 Wash the pooled eggs three times using control water with gentle centrifugation (500xg for 3 minutes using a tabletop centrifuge). If the wash water becomes red, the eggs have lysed and must be discarded.

15.10.4.2 Dilute the egg stock, using control water, to about 2000 eggs/mL.

1. Transfer the eggs to a glass beaker containing 200 mL of control water ("egg stock").
2. Mix the egg stock using an air-bubbling device. Using a wide-mouth pipet tip, transfer 1 mL of eggs from the egg stock to a vial containing 9 mL of control water. (This vial contains an egg suspension diluted 1:10 from egg stock).
3. Mix the contents of the vial by inversion. Using a wide-mouth pipet tip, transfer 1 mL of eggs from the vial to a Sedgwick-Rafter counting chamber. Count all eggs in the chamber using a dissecting microscope at 24X "egg count".
4. Calculate the concentration of eggs in the stock. Eggs/mL = 10X (egg count). Dilute the egg stock to 2000 eggs/mL by the formula below.
 - a. If the egg count is equal to or greater than 200:
(egg count) - 200 = volume (mL) of control water to add to egg stock.
 - b. If the egg count is less than 200, allow the eggs to settle and remove enough control water to concentrate the eggs to greater than 200, repeat the count, and dilute the egg stock as in a. above. NOTE: It requires 24 mL of a egg stock solution for each test with a control and five exposure concentrations.
 - c. Transfer 1 mL of the diluted egg stock to a vial containing 9 mL of control water. Mix well, then transfer 1 mL from the vial to a Sedgwick-Rafter counting chamber. Count all eggs using a

dissecting microscope. Confirm that the final egg count = 2000/mL (\pm 200).

15.10.5 LIGHT, PHOTOPERIOD, SALINITY AND TEMPERATURE

15.10.5.1 The light quality and intensity should be at ambient laboratory levels 10-20 $\mu\text{E}/\text{m}^2/\text{s}$ (50-100 ft-c) with a photoperiod of 16 h light and 8 h darkness. The water temperature in the test chambers should be maintained at $20 \pm 1^\circ\text{C}$. The test salinity should be in the range of 28 to 32‰. The salinity should vary by no more than $\pm 2\%$ among the chambers on a given day. If effluent and receiving water tests are conducted concurrently, the salinities of these tests should be similar.

15.10.6 DISSOLVED OXYGEN (DO) CONCENTRATION

15.10.6.1 Aeration may affect the toxicity of effluent and should be used only as a last resort to maintain a satisfactory DO. The DO concentrations should be measured on new solutions at the start of the test (Day 0). The DO should not fall below 4.0 mg/L (see Section 8, Effluent and Receiving Water Sampling, Sample Handling, and Sample Preparation for Toxicity Tests). If it is necessary to aerate, all treatments and the control should be aerated. The aeration rate should not exceed 100 bubbles/minute, using a pipet with a 1-2 mm orifice, such as a 1 mL KIMAX® serological pipet No. 37033, or equivalent.

15.10.7 OBSERVATIONS DURING THE TEST

15.10.7.1 Routine Chemical and Physical Observations

15.10.7.1.1 DO is measured at the beginning of the exposure period in one test chamber at each test concentration and in the control.

15.10.7.1.2 Temperature, pH, and salinity are measured at the beginning of the exposure period in one test chamber at each concentration and in the control. Temperature should also be monitored continuously observed and recorded daily for at least two locations in the environmental control system or the samples. Temperature should be measured in a sufficient number of test chambers at least at the end of the test to determine temperature variation in environmental chamber.

15.10.7.1.3 The pH is measured in the effluent sample each day before new test solutions are made.

15.10.7.1.4 Record all the measurements on the data sheet.

15.10.7.2 Routine Biological Observations

15.10.7.2.1 Fertilization will be determined by the presence of a fertilization membrane surrounding the egg.

15.10.8 START OF THE TEST

15.10.8.1 Effluent/receiving water samples are adjusted to salinity of 30‰. Four replicates (minimum of three) are prepared for each test concentration, using 5 mL of solution in disposable liquid scintillation vials. A 50% (0.5) concentration series can be prepared by serially diluting test concentrations with control water. Sufficient test solution is prepared at each effluent concentration to provide additional volume for chemical analyses, at the high, medium, and low test concentrations.

15.10.8.2 All test samples are equilibrated at $20^{\circ}\text{C} \pm 1^{\circ}\text{C}$ before addition of sperm.

15.10.8.3 Within 1 h of collection add 100 μL of appropriately diluted sperm to each test vial. Record the time of sperm addition.

15.10.8.4 Incubate all test vials at $20 \pm 1^{\circ}\text{C}$ for 1 h.

15.10.8.5 Mix the diluted egg suspension (2000 eggs/mL), using gentle bubbling. Add 1 mL of diluted egg suspension to each test vial using a wide mouth pipet tip. Incubate 20 min at $20 \pm 1^{\circ}\text{C}$.

15.10.9 TERMINATION OF THE TEST

15.10.9.1 Terminate the test and preserve the samples by adding 2 mL of 1% formalin in seawater to each vial.

15.10.9.2 Vials should be evaluated within 48 hours.

15.10.9.3 To determine fertilization, transfer about 1 mL eggs from the bottom of a test vial to a Sedgwick-Rafter counting chamber. Observe the eggs using a compound microscope (100X). Count between 100 and 200 eggs/sample. Record the number counted and the number unfertilized. Fertilization is indicated by the presence of a fertilization membrane surrounding the egg. Note: adjustment of the microscope to obtain proper contrast may be required to observe the fertilization membrane. Because samples are fixed in formalin, a ventilation hood is set up surrounding the microscope to protect the analyst from prolonged exposure to formaldehyde fumes.

15.11 SUMMARY OF TEST CONDITIONS AND TEST ACCEPTABILITY CRITERIA

15.11.1 A summary of test conditions and test acceptability criteria is listed in Table 3.

15.12 ACCEPTABILITY OF TEST RESULTS

15.12.1 The sperm:egg ratio routinely employed should result in fertilization of 70%-90% of the eggs in the control chambers.

TABLE 3. SUMMARY OF TEST CONDITIONS AND TEST ACCEPTABILITY CRITERIA FOR SEA URCHIN, *ARBACIA PUNCTULATA*, FERTILIZATION TEST WITH EFFLUENT AND RECEIVING WATERS

1. Test type:	Static
2. Salinity:	30‰ (± 2‰ of the selected test salinity)
3. Temperature:	20 ± 1°C
4. Light quality:	Ambient laboratory light during test preparation
5. Light intensity:	10-20 $\mu\text{E}/\text{m}^2/\text{s}$, or 50-100 ft-c (Ambient laboratory levels)
6. Test chamber size:	Disposable (glass) liquid scintillation vials (20 mL capacity), presoaked in control water
7. Test solution volume:	5 mL
8. No. of sea urchins:	Pooled sperm from four males and pooled eggs from four females are used per test
9. No. egg and sperm cells per chamber:	About 2000 eggs and 5, 000,000 sperm cells per vial
10. No. replicate chambers per concentration:	4 (minimum of 3)
11. Dilution water:	Uncontaminated source of natural seawater; deionized water mixed with hypersaline brine or artificial sea salts (HW Marinemix®, FORTY FATHOMS®, GP2, or equivalent)
12. Effluent concentrations:	Effluents: Minimum of 5 and a control Receiving waters: 100% receiving water or minimum of 5 and a control

TABLE 3. SUMMARY OF TEST CONDITIONS AND TEST ACCEPTABILITY CRITERIA FOR SEA URCHIN, *ARBACIA PUNCTULATA*, FERTILIZATION TEST WITH EFFLUENT AND RECEIVING WATERS (CONTINUED)

13. Test dilution factor:	Effluents: ≥ 0.5 Receiving waters: None or ≥ 0.5
14. Test duration:	1 h and 20 min
15. Endpoint:	Fertilization of sea urchin eggs
16. Test acceptability criteria:	70% - 90% egg fertilization in controls
17. Sampling requirements:	One sample collected at test initiation, and preferably used within 24 h of the time it is removed from the sampling device (see Section 8, Effluent and Receiving Water Sampling, Sample Handling, and Sample Preparation for Toxicity Tests, Subsection 8.5.4)
18. Sample volume required:	1 L per test

15.13 DATA ANALYSIS

15.13.1 GENERAL

15.13.1.1 Tabulate and summarize the data. Calculate the proportion of fertilized eggs for each replicate. A sample set of test data is listed in Table 4.

15.13.1.2 The statistical tests described here must be used with a knowledge of the assumptions upon which the tests are contingent. The assistance of a statistician is recommended for analysts who are not proficient in statistics.

TABLE 4. DATA FROM SEA URCHIN, *ARBACIA PUNCTULATA*, FERTILIZATION TEST¹

Copper Concentration ($\mu\text{g/L}$)	Replicate	No. of Eggs Counted	No. of Eggs Fertilized	Proportion Fertilized
Control	A	100	85	0.85
	B	100	78	0.78
	C	100	87	0.87
2.5	A	100	81	0.81
	B	100	65	0.65
	C	100	71	0.71
5.0	A	100	63	0.63
	B	100	74	0.74
	C	100	78	0.78
10.0	A	100	63	0.63
	B	100	66	0.66
	C	100	51	0.51
20.0	A	100	41	0.41
	B	100	41	0.41
	C	100	37	0.37
40.0	A	100	12	0.12
	B	100	30	0.30
	C	100	26	0.26

¹ Tests performed by Dennis M. McMullen, Technology Applications, Inc., EMSL, Cincinnati, OH.

15.13.1.3 The endpoints of toxicity tests using the sea urchin are based on the reduction in proportion of eggs fertilized. The IC₂₅ and the IC₅₀ are calculated using the Linear Interpolation Method (see Section 9, Chronic Toxicity Test Endpoints and Data Analysis). LOEC and NOEC values for fecundity are obtained using a hypothesis testing approach such as Dunnett's Procedure (Dunnett, 1955) or Steel's Many-one Rank Test (Steel, 1959; Miller,

1981) (see Section 9). Separate analyses are performed for the estimation of the LOEC and NOEC endpoints and for the estimation of IC25 and IC50. See the Appendices for examples of the manual computations, and examples of data input and program output.

15.13.2 EXAMPLE OF ANALYSIS OF SEA URCHIN, *ARBACIA PUNCTULATA*, FERTILIZATION DATA

15.13.2.1 Formal statistical analysis of the fertilization data is outlined in Figure 4. The response used in the analysis is the proportion of fertilized eggs in each test or control chamber. Separate analyses are performed for the estimation of the NOEC and LOEC endpoints and for the estimation of the IC25 and IC50 endpoints. Concentrations at which there are no eggs fertilized in any of the test chambers are excluded from statistical analysis of the NOEC and LOEC, but included in the estimation of the IC25 and IC50.

15.13.2.2 For the case of equal numbers of replicates across all concentrations and the control, the evaluation of the NOEC and LOEC endpoints is made via a parametric test, Dunnett's Procedure, or a nonparametric test, Steel's Many-one Rank Test, on the arc sine square root transformed data. Underlying assumptions of Dunnett's Procedure, normality and homogeneity of variance, are formally tested. The test for normality is the Shapiro-Wilk's Test, and Bartlett's Test is used to test for homogeneity of variance. If either of these tests fails, the nonparametric test, Steel's Many-one Rank Test, is used to determine the NOEC and LOEC endpoints. If the assumptions of Dunnett's Procedure are met, the endpoints are estimated by the parametric procedure.

15.13.2.3 If unequal numbers of replicates occur among the concentration levels tested, there are parametric and nonparametric alternative analyses. The parametric analysis is a t test with the Bonferroni adjustment (see Appendix D). The Wilcoxon Rank Sum Test with the Bonferroni adjustment is the nonparametric alternative.

15.13.2.4 Example of Analysis of Fecundity Data

15.13.2.4.1 This example uses toxicity data from a sea urchin, *Arbacia punctulata*, fertilization test performed with copper. The response of interest is the proportion of fertilized eggs, thus each replicate must first be transformed by the arc sine square root transformation procedure described in Appendix B. The raw and transformed data, means and variances of the transformed observations at each copper concentration and control are listed in Table 5. The data are plotted in Figure 5.

15.13.2.5 Test for Normality

15.13.2.5.1 The first step of the test for normality is to center the observations by subtracting the mean of all observations within a concentration from each observation in that concentration. The centered observations are summarized in Table 6.

STATISTICAL ANALYSIS OF SEA URCHIN FERTILIZATION TEST

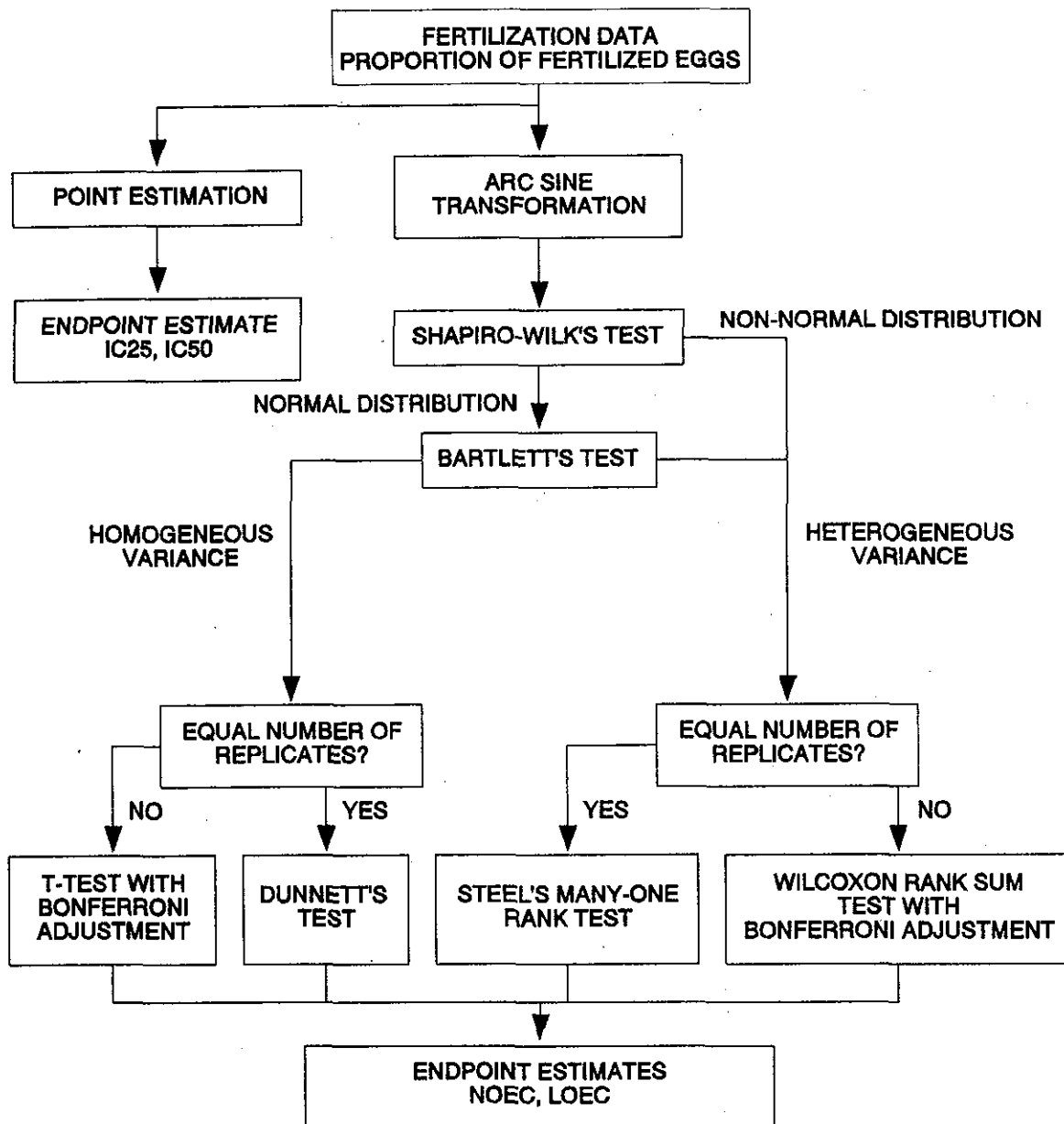

Figure 4. Flowchart for statistical analysis of sea urchin, *Arbacia punctulata*, by point estimation.

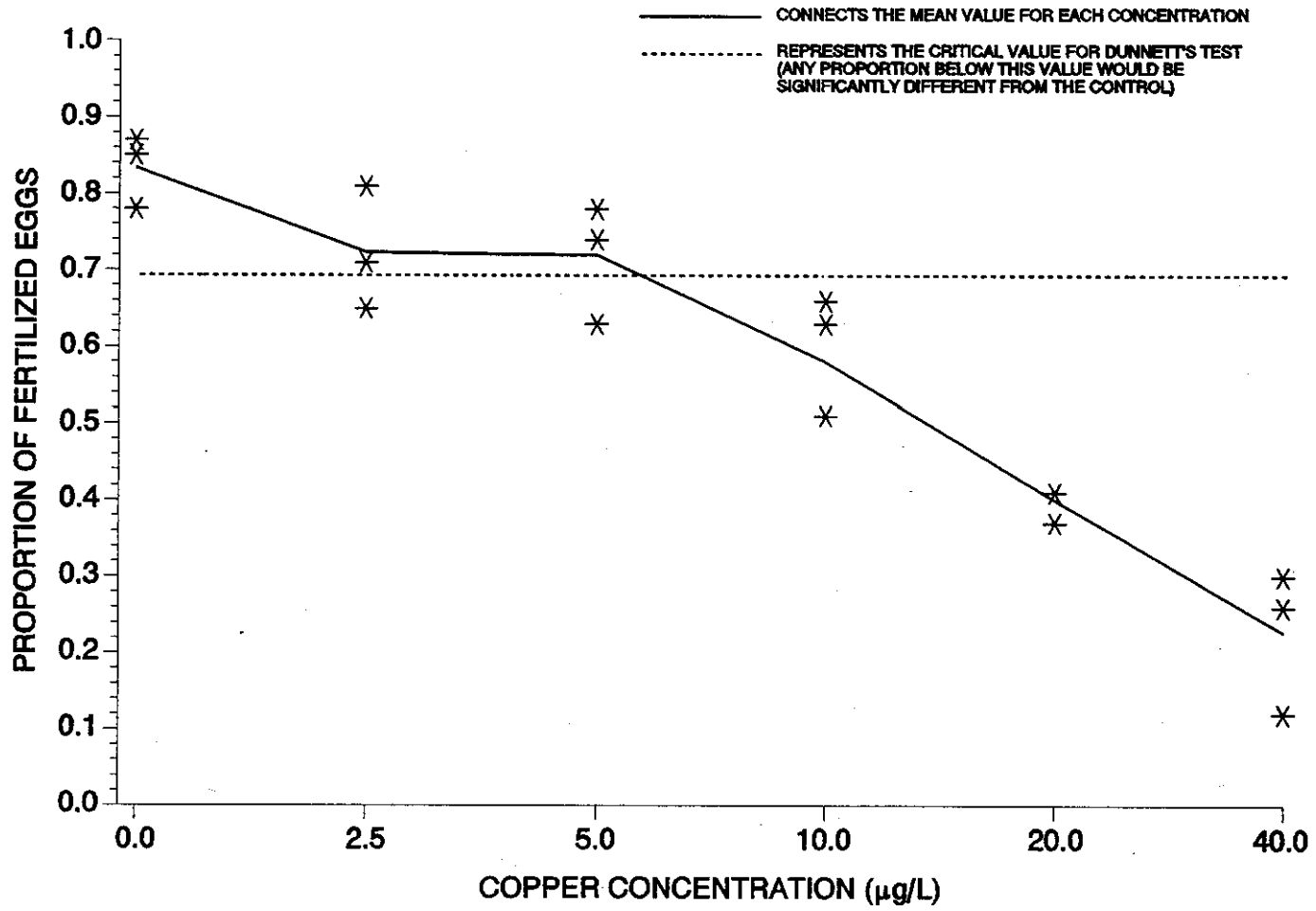

Figure 5. Plot of mean percent of fertilized sea urchin, *Arbacia punctulata*, eggs.

TABLE 5. SEA URCHIN, *ARBACIA PUNCTULATA*, FERTILIZATION DATA

		Copper Concentration ($\mu\text{g/L}$)					
Replicate		Control	2.5	5.0	10.0	20.0	40.0
RAW	A	0.85	0.81	0.63	0.63	0.41	0.12
	B	0.78	0.65	0.74	0.66	0.41	0.30
	C	0.87	0.71	0.78	0.51	0.37	0.26
ARC SINE TRANSFORMED	A	1.173	1.120	0.917	0.917	0.695	0.354
	B	1.083	0.938	1.036	0.948	0.695	0.580
	C	1.202	1.002	1.083	0.795	0.654	0.535
Mean (\bar{Y}_i)		1.153	1.020	1.012	0.887	0.681	0.490
S_i^2		0.004	0.009	0.007	0.007	0.001	0.014
i		1	2	3	4	5	6

TABLE 6. CENTERED OBSERVATIONS FOR SHAPIRO-WILK'S EXAMPLE

		Copper Concentration ($\mu\text{g/L}$)				
Replicate	Control	2.5	5.0	10.0	20.0	40.0
A	0.020	0.100	-0.095	0.030	0.014	-0.136
B	-0.070	-0.082	0.024	0.061	0.014	0.090
C	0.049	-0.018	0.071	-0.092	-0.027	0.045

15.13.2.5.2 Calculate the denominator, D , of the statistic:

$$D = \sum_{i=1}^n (X_i - \bar{X})^2$$

Where: X_i = the i th centered observation

\bar{X} = the overall mean of the centered observations

n = the total number of centered observations

15.13.2.5.3 For this set of data, $n = 18$

$$\bar{X} = \frac{1}{18} (0) = 0$$

$$D = 0.0822$$

15.13.2.5.4 Order the centered observations from smallest to largest

$$X^{(1)} \leq X^{(2)} \leq \dots \leq X^{(n)}$$

where $X^{(i)}$ denotes the i th ordered observation. The ordered observations for this example are listed in Table 7.

TABLE 7. ORDERED CENTERED OBSERVATIONS FOR SHAPIRO-WILK'S EXAMPLE

i	$X^{(i)}$	i	$X^{(i)}$
1	-0.136	10	0.020
2	-0.095	11	0.024
3	-0.092	12	0.030
4	-0.082	13	0.045
5	-0.070	14	0.049
6	-0.027	15	0.061
7	-0.018	16	0.071
8	0.014	17	0.090
9	0.014	18	0.100

15.13.2.5.5 From Table 4, Appendix B, for the number of observations, n , obtain the coefficients a_1, a_2, \dots, a_k where k is $n/2$ if n is even and $(n-1)/2$ if n is odd. For the data in this example, $n = 18$ and $k = 9$. The a_i values are listed in Table 8.

15.13.2.5.6 Compute the test statistic, W , as follows:

$$W = \frac{1}{D} \left[\sum_{i=1}^k a_i (X^{(n-i+1)} - X^{(i)}) \right]^2$$

The differences, $X^{(n-i+1)} - X^{(i)}$, are listed in Table 7. For the data in this example:

$$W = \frac{1}{0.0822} (0.2782)^2 = 0.942$$

15.13.2.5.7 The decision rule for this test is to compare W as calculated in 2.6 to a critical value found in Table 6, Appendix B. If the computed W is less than the critical value, conclude that the data are not normally distributed. For the data in this example, the critical value at a significance level of 0.01 and $n = 18$ observations is 0.858. Since $W = 0.942$ is greater than the critical value, conclude that the data are normally distributed.

TABLE 8. COEFFICIENTS AND DIFFERENCES FOR SHAPIRO-WILK'S EXAMPLE

i	a_i	$\chi^{(n-i+1)} - \chi^{(i)}$	
1	0.4886	0.236	$\chi^{(18)} - \chi^{(1)}$
2	0.3253	0.185	$\chi^{(17)} - \chi^{(2)}$
3	0.2553	0.163	$\chi^{(16)} - \chi^{(3)}$
4	0.2027	0.143	$\chi^{(15)} - \chi^{(4)}$
5	0.1587	0.119	$\chi^{(14)} - \chi^{(5)}$
6	0.1197	0.072	$\chi^{(13)} - \chi^{(6)}$
7	0.0837	0.048	$\chi^{(12)} - \chi^{(7)}$
8	0.0496	0.010	$\chi^{(11)} - \chi^{(8)}$
9	0.0163	0.006	$\chi^{(10)} - \chi^{(9)}$

15.13.2.6 Test for Homogeneity of Variance

15.13.2.6.1 The test used to examine whether the variation in the proportion of fertilized eggs is the same across all copper concentrations including the control, is Bartlett's Test (Snedecor and Cochran, 1980). The test statistic is as follows:

$$B = \frac{[(\sum_{i=1}^p V_i) \ln \bar{S}^2 - \sum_{i=1}^p V_i \ln S_i^2]}{C}$$

Where: V_i = degrees of freedom for each copper concentration and control,
 $V_i = (n_i - 1)$

p = number of levels of copper concentration including the control

n_i = the number of replicates for concentration i .

\ln = \log_e

i = 1, 2, ..., p where p is the number of concentrations including the control

$$\bar{S}^2 = \frac{(\sum_{i=1}^p V_i S_i^2)}{\sum_{i=1}^p V_i}$$

$$C = 1 + [3(p-1)]^{-1} [\sum_{i=1}^p 1/V_i - (\sum_{i=1}^p V_i)^{-1}]$$

15.13.2.6.2 For the data in this example (see Table 5), all copper concentrations including the control have the same number of replicates ($n_i = 3$ for all i). Thus, $V_i = 2$ for all i .

15.13.2.6.3 Bartlett's statistic is, therefore:

$$\begin{aligned}
 B &= [(12) \ln(0.0007) - 2 \sum_{i=1}^p \ln(S_i^2)] / 1.194 \\
 &= [12(-4.962) - 2(-31.332)] / 1.194 \\
 &= 3.122 / 1.194 \\
 &= 3.615
 \end{aligned}$$

15.13.2.6.4 B is approximately distributed as chi-square with $p-1$ degrees of freedom, when the variances are in fact the same. Therefore, the appropriate critical value for this test, at a significance level of 0.01 with 5 degrees of freedom, is 15.09. Since $B = 2.615$ is less than the critical value of 15.09, conclude that the variances are not different.

15.13.2.7 Dunnett's Procedure

15.13.2.7.1 To obtain an estimate of the pooled variance for the Dunnett's Procedure, construct an ANOVA table as described in Table 9.

TABLE 9. ANOVA TABLE

Source	df	Sum of Squares (SS)	Mean Square (MS) (SS/df)
Between	$p - 1$	SSB	$S_B^2 = \text{SSB}/(p-1)$
Within	$N - p$	SSW	$S_W^2 = \text{SSW}/(N-p)$
Total	$N - 1$	SST	

Where: p = number of copper concentrations including the control

N = total number of observations $n_1 + n_2 \dots + n_p$

n_i = number of observations in concentration i

$$SSB = \sum_{i=1}^p T_i^2/n_i - G^2/N \quad \text{Between Sum of Squares}$$

$$SST = \sum_{i=1}^p \sum_{j=1}^{n_i} Y_{ij}^2 - G^2/N \quad \text{Total Sum of Squares}$$

$$SSW = SST - SSB \quad \text{Within Sum of Squares}$$

G = the grand total of all sample observations, $G = \sum_{i=1}^p T_i$

T_i = the total of the replicate measurements for concentration i

Y_{ij} = the j th observation for concentration i (represents the proportion of fertilized eggs for copper concentration i in test chamber j)

15.13.2.7.2 For the data in this example:

$$n_1 = n_2 = n_3 = n_4 = n_5 = n_6 = 3$$

$$N = 18$$

$$T_1 = Y_{11} + Y_{12} + Y_{13} = 3.458$$

$$T_2 = Y_{21} + Y_{22} + Y_{23} = 3.060$$

$$T_3 = Y_{31} + Y_{32} + Y_{33} = 3.036$$

$$T_4 = Y_{41} + Y_{42} + Y_{43} = 2.660$$

$$T_5 = Y_{51} + Y_{52} + Y_{53} = 2.044$$

$$T_6 = Y_{61} + Y_{62} + Y_{63} = 1.469$$

$$G = T_1 + T_2 + T_3 + T_4 + T_5 + T_6 = 15.727$$

$$\begin{aligned} SSB &= \sum_{i=1}^p T_i^2/n_i - G^2/N \\ &= (43.950)/3 - (15.727)^2/18 = 0.909 \end{aligned}$$

$$\begin{aligned} SST &= \sum_{i=1}^p \sum_{j=1}^{n_i} Y_{ij}^2 - G^2/N \\ &= 14.732 - (15.727)^2/18 = 0.991 \end{aligned}$$

$$SSW = SST - SSB = 0.991 - 0.909 = 0.082$$

$$S_B^2 = SSB/(p-1) = 0.909/(6-1) = 0.182$$

$$S_W^2 = SSW/(N-p) = 0.082/(18-6) = 0.007$$

15.13.2.7.3 Summarize these calculations in the ANOVA table (Table 10).

TABLE 10. ANOVA TABLE FOR DUNNETT'S PROCEDURE EXAMPLE

Source	df	Sum of Squares (SS)	Mean Square (MS) (SS/df)
Between	5	0.909	0.182
Within	12	0.082	0.007
Total	17	0.991	

15.13.2.7.4 To perform the individual comparisons, calculate the t statistic for each concentration, and control combination as follows:

$$t_i = \frac{(\bar{Y}_1 - \bar{Y}_i)}{S_W \sqrt{(1/n_1) + (1/n_i)}}$$

Where: \bar{Y}_i = mean proportion fertilized eggs for copper concentration i

\bar{Y}_1 = mean proportion fertilized eggs for the control

S_W = square root of the within mean square

n_1 = number of replicates for the control

n_i = number of replicates for concentration i.

Since we are looking for a decreased response from the control in the proportion of fertilized eggs, the concentration mean is subtracted from the control mean.

15.13.2.7.5 Table 11 includes the calculated t values for each concentration and control combination. In this example, comparing the 2.5 µg/L concentration with the control the calculation is as follows:

$$t_2 = \frac{(1.153 - 1.020)}{[0.084\sqrt{(1/3) + (1/3)}]} = 1.939$$

TABLE 11. CALCULATED T VALUES

Copper Concentration (µg/L)	i	t _i
2.5	2	1.939
5.0	3	2.056
10.0	4	3.878
20.0	5	6.882
40.0	6	9.667

15.13.2.7.6 Since the purpose of this test is to detect a significant decrease in the proportion of fertilized eggs, a one-sided test is appropriate. The critical value for this one-sided test is found in Table 5, Appendix D. For an overall alpha level of 0.05, 12 degrees of freedom for error and five concentrations (excluding the control) the critical value is 2.50. The mean proportion of fertilized eggs for concentration i is considered significantly less than the mean proportion of fertilized eggs for the control if t_i is greater than the critical value. Therefore, the 10.0 µg/L, 20.0 µg/L and 40.0 µg/L concentrations have a significantly lower mean proportion of fertilized eggs than the control. Hence the NOEC is 5.0 µg/L and the LOEC is 10.0 µg/L.

15.13.2.7.7 To quantify the sensitivity of the test, the minimum significant difference (MSD) that can be statistically detected may be calculated:

$$MSD = d S_w \sqrt{(1/n_1) + (1/n)}$$

Where: d = the critical value for Dunnett's Procedure

S_w = the square root of the within mean square

n = the common number of replicates at each concentration (this assumes equal replication at each concentration)

n₁ = the number of replicates in the control.

15.13.2.7.8 In this example,

$$\begin{aligned} MSD &= 2.50 (0.084) \sqrt{(1/3) + (1/3)} \\ &= 2.50 (0.084)(0.816) \\ &= 0.171 \end{aligned}$$

15.13.2.7.9 The MSD (0.171) is in transformed units. To determine the MSD in terms of proportion of fertilized eggs, carry out the following conversion.

1. Subtract the MSD from the transformed control mean.

$$1.153 - 0.171 = 0.982$$

2. Obtain the untransformed values for the control mean and the difference calculated in step 1 of 13.2.7.9.

$$[\text{Sine} (1.153)]^2 = 0.835$$

$$[\text{Sine} (0.982)]^2 = 0.692$$

3. The untransformed MSD (MSD_u) is determined by subtracting the untransformed values from step 2 in 14.2.7.9.

$$\text{MSD}_u = 0.835 - 0.692 = 0.143$$

15.13.2.7.10 Therefore, for this set of data, the minimum difference in mean proportion of fertilized eggs between the control and any copper concentration that can be detected as statistically significant is 0.143.

15.13.2.7.11 This represents a 17% decrease in the proportion of fertilized eggs from the control.

15.13.2.8 Calculation of the ICp

15.13.2.8.1 The fertilization data in Table 4 are utilized in this example. Table 12 contains the mean proportion of fertilized eggs for each toxicant concentration. As can be seen, the observed means are monotonically non-increasing with respect to concentration. Therefore, it is not necessary to smooth the means prior to calculating the ICp; (see Figure 5 for a plot of the response curve).

15.13.2.8.2 An IC25 and IC50 can be estimated using the Linear Interpolation Method. A 25% reduction in mean proportion of fertilized eggs, compared to the controls, would result in a mean proportion of 0.625, where $M_1(1-p/100) = 0.833(1-25/100)$. A 50% reduction in mean proportion of fertilized eggs, compared to the controls, would result in a mean proportion of 0.417. Examining the means and their associated concentrations (Table 12), the response, 0.625, is bracketed by $C_3 = 5.0 \mu\text{g/L}$ copper and $C_4 = 10.0 \mu\text{g/L}$ copper. The response, 0.417, is bracketed by $C_4 = 10.0 \mu\text{g/L}$ copper and $C_5 = 20.0 \mu\text{g/L}$ copper.

TABLE 12. SEA URCHIN, *ARBACIA PUNCTULATA*, MEAN PROPORTION OF FERTILIZED EGGS

Copper Conc. ($\mu\text{g/L}$)	i	Response Means, \bar{Y}_i (proportion)	Smoothed Means, M_i (proportion)
Control	1	0.833	0.833
2.5	2	0.723	0.723
5.0	3	0.717	0.717
10.0	4	0.600	0.600
20.0	5	0.397	0.397
40.0	6	0.227	0.227

15.13.2.8.3 Using the equation from Section 4.2 in Appendix L, the estimate of the IC25 is calculated as follows:

$$IC_p = C_j + [M_1(1-p/100) - M_j] \frac{(C_{(j+1)} - C_j)}{(M_{(j+1)} - M_j)}$$

$$\begin{aligned} IC_{25} &= 5.0 + [0.833(1 - 25/100) - 0.717] \frac{(10.0 - 5.0)}{(0.600 - 0.717)} \\ &= 8.9 \mu\text{g/L}. \end{aligned}$$

15.13.2.8.4 Using the equation from Section 4.2 in Appendix L, the estimate of the IC50 is calculated as follows:

$$IC_p = C_j + [M_1(1-p/100) - M_j] \frac{(C_{(j+1)} - C_j)}{(M_{(j+1)} - M_j)}$$

$$\begin{aligned} IC_{50} &= 10.0 + [0.833(1 - 50/100) - 0.600] \frac{(20.0 - 10.0)}{(0.397 - 0.600)} \\ &= 19.0 \mu\text{g/L}. \end{aligned}$$

15.13.2.8.5 When the ICPIN program was used to analyze this set of data, requesting 80 resamples, the estimate of the IC25 was 8.9286 $\mu\text{g/L}$. The empirical 95.0% confidence interval for the true mean was 3.3036 $\mu\text{g/L}$ to 14.6025 $\mu\text{g/L}$. The computer program output for the IC25 for this data set is shown in Figure 6.

15.13.2.8.6 When the ICPIN program was used to analyze this set of data, requesting 80 resamples, the estimate of the IC50 was 19.0418 $\mu\text{g/L}$.

Conc. ID	1	2	3	4	5	6
Conc. Tested	0	2.5	5.0	10.0	20.0	40.0
Response 1	.85	.81	.63	.63	.41	.12
Response 2	.78	.65	.74	.66	.41	.3
Response 3	.87	.71	.78	.51	.37	.26

*** Inhibition Concentration Percentage Estimate ***

Toxicant/Effluent: Copper

Test Start Date: Test Ending Date:

Test Species: SEA URCHIN, Arbacia punctulata

Test Duration:

DATA FILE: urchin.icp

OUTPUT FILE: urchin.i25

Conc. ID	Number Replicates	Concentration ug/l	Response Means	Std. Dev.	Pooled Response Means
1	3	0.000	0.833	0.047	0.833
2	3	2.500	0.723	0.081	0.723
3	3	5.000	0.717	0.078	0.717
4	3	10.000	0.600	0.079	0.600
5	3	20.000	0.397	0.023	0.397
6	3	40.000	0.227	0.095	0.227

The Linear Interpolation Estimate: 8.9286 Entered P Value: 25

Number of Resamplings: 80

The Bootstrap Estimates Mean: 8.7092 Standard Deviation: 1.5324

Original Confidence Limits: Lower: 6.2500 Upper: 11.6304

Expanded Confidence Limits: Lower: 3.3036 Upper: 14.6025

Resampling time in Seconds: 1.59 Random Seed: 1834854321

Figure 6. ICPIN program output for the IC25.

The empirical 95.0% confidence interval for the true mean was 16.1083 $\mu\text{g/L}$ to 23.6429 $\mu\text{g/L}$. The computer program output for the IC50 for this data set is shown in Figure 7.

15.14 PRECISION AND ACCURACY

15.14.1 PRECISION

15.14.1.1 Single-Laboratory Precision

15.14.1.1.1 Single-laboratory precision data for the reference toxicants, copper (Cu) and sodium dodecyl sulfate (SDS), tested in FORTY FATHOMS® artificial seawater, GP2 artificial seawater, and natural seawater are provided in Tables 13-18. The test results were similar in the three types of seawater. The IC25 and IC50 for the reference toxicants (copper and sodium dodecyl sulfate) are reported in Tables 13-16. The coefficient of variation, based on the IC25, is 28.7% to 54.6% for natural and FORTY FATHOMS® seawater, indicating acceptable precision. The IC50 ranges from 23.3% to 48.2%, showing acceptable precision.

15.14.1.2 Multilaboratory Precision

15.14.1.2.1 No data are available on the multilaboratory precision of the test.

15.14.2 ACCURACY

15.14.2.1 The accuracy of toxicity tests cannot be determined.

Conc. ID	1	2	3	4	5	6
Conc. Tested	0	2.5	5.0	10.0	20.0	40.0
Response 1	.85	.81	.63	.63	.41	.12
Response 2	.78	.65	.74	.66	.41	.3
Response 3	.87	.71	.78	.51	.37	.26

*** Inhibition Concentration Percentage Estimate ***

Toxicant/Effluent: Copper

Test Start Date: Test Ending Date:

Test Species: SEA URCHIN, Arbacia punctulata

Test Duration:

DATA FILE: urchin.icp

OUTPUT FILE: urchin.i50

Conc. ID	Number Replicates	Concentration ug/l	Response Means	Std. Dev.	Pooled Response Means
1	3	0.000	0.833	0.047	0.833
2	3	2.500	0.723	0.081	0.723
3	3	5.000	0.717	0.078	0.717
4	3	10.000	0.600	0.079	0.600
5	3	20.000	0.397	0.023	0.397
6	3	40.000	0.227	0.095	0.227

The Linear Interpolation Estimate: 19.0164 Entered P Value: 50

Number of Resamplings: 80

The Bootstrap Estimates Mean: 19.0013 Standard Deviation: 0.8973

Original Confidence Limits: Lower: 17.6316 Upper: 21.2195

Expanded Confidence Limits: Lower: 16.1083 Upper: 23.6429

Resampling time in Seconds: 1.65 Random Seed: -823775279

Figure 7. ICPIN program output for the IC50.

TABLE 13. SINGLE-LABORATORY PRECISION OF THE SEA URCHIN, *ARBACIA PUNCTULATA*, FERTILIZATION TEST PERFORMED IN FORTY FATHOMS® ARTIFICIAL SEAWATER, USING GAMETES FROM ADULTS MAINTAINED IN FORTY FATHOMS® ARTIFICIAL SEAWATER, OR OBTAINED DIRECTLY FROM NATURAL SOURCES, AND COPPER (CU) SULFATE AS A REFERENCE TOXICANT^{1,2,3,4,5}

Test Number	LOEC (µg/L)	IC25 (µg/L)	IC50 (µg/L)
1	5.0	8.92	29.07
2	12.5	26.35	38.96
3	< 6.2	11.30	23.93
4	6.2	34.28	61.75
5	12.5	36.67	75.14
n:	4	5	5
Mean:	NA	23.51	45.77
CV(%):	NA	54.60	47.87

¹ Data from USEPA (1991a)

² Tests performed by Dennis McMullen, Technology Applications, Inc., EMSL, Cincinnati, OH.

² All tests were performed using FORTY FATHOMS® synthetic seawater.

³ Copper test solutions were prepared with copper sulfate. Copper concentrations in Test 1 were: 2.5, 5.0, 10.0, 20.0, and 40.0 µg/L. Copper concentrations in Tests 2-5 were: 6.25, 12.5, 25.0, 50.0, and 100.0 µg/L.

⁴ NOEC Range: < 5.0 - 12.5 µg/L (this represents a difference of one exposure concentrations).

⁵ For a discussion of the precision of data from chronic toxicity tests see Section 4, Quality Assurance.

TABLE 14. SINGLE-LABORATORY PRECISION OF THE SEA URCHIN, *ARBACIA PUNCTULATA*, FERTILIZATION TEST PERFORMED IN FORTY FATHOMS® ARTIFICIAL SEAWATER, USING GAMETES FROM ADULTS MAINTAINED IN FORTY FATHOMS® ARTIFICIAL SEAWATER, OR OBTAINED DIRECTLY FROM NATURAL SOURCES, AND SODIUM DODECYL SULFATE (SDS) AS A REFERENCE TOXICANT^{1,2,3,4,5,6}

Test Number	NOEC (mg/L)	IC25 (mg/L)	IC50 (mg/L)
1	< 0.9	1.11	1.76
2	0.9	1.27	1.79
3	1.8	2.26	2.87
4	0.9	1.90	2.69
5	1.8	2.11	2.78
n:	4	5	5
Mean:	NA	1.73	2.38
CV(%):	NA	29.7	23.3

¹ Data from USEPA (1991a)

² Tests performed by Dennis M. McMullen, Technology Applications, Inc., EMSL, Cincinnati, OH.

³ All tests were performed using FORTY FATHOMS® synthetic seawater.

⁴ NOEC Range: 1.2 -3.3 mg/L (this represents a difference of one exposure concentration).

⁵ SDS concentrations for all tests were: 0.9, 1.8, 3.6, 7.2, and 14.4 mg/L.

⁶ For a discussion of the precision of data from chronic toxicity tests see Section 4, Quality Assurance.

TABLE 15. SINGLE-LABORATORY PRECISION OF THE SEA URCHIN, *ARBACIA PUNCTULATA*, FERTILIZATION TEST PERFORMED IN NATURAL SEAWATER, USING GAMETES FROM ADULTS MAINTAINED IN NATURAL SEAWATER AND COPPER (CU) SULFATE AS A REFERENCE TOXICANT ^{1,2,3,4,5,6}

Test Number	NOEC (µg/L)	IC25 (µg/L)	IC50 (µg/L)
1	12.2	14.2	18.4
2	12.2	32.4	50.8
3	24.4	30.3	46.3
4	< 6.1	26.2	34.1
5	6.1	11.2	17.2
n:	4	5	5
Mean:	NA	22.8	29.9
CV(%):	NA	41.9	48.2

¹ Data from USEPA (1991a)

² Tests performed by Ray Walsh and Wendy Greene, ERL-N, USEPA, Narragansett, RI.

³ Copper concentrations were: 6.1, 12.2, 24.4, 48.7, and 97.4 µg/L.

⁴ NOEC Range: < 6.1 - 24.4 µg/L (this represents a difference of two exposure concentrations).

⁵ Adults collected in the field.

⁶ For a discussion of the precision of data from chronic toxicity tests see Section 4, Quality Assurance.

TABLE 16. SINGLE-LABORATORY PRECISION OF THE SEA URCHIN, *ARBACIA PUNCTULATA*, FERTILIZATION TEST PERFORMED IN NATURAL SEAWATER, USING GAMETES FROM ADULTS MAINTAINED IN NATURAL SEAWATER AND SODIUM DODECYL SULFATE (SDS) AS A REFERENCE TOXICANT ^{1,2,3,4,5,6}

Test Number	NOEC (mg/L)	IC25 (mg/L)	IC50 (mg/L)
1	1.8	2.3	2.7
2	1.8	3.9	5.1
3	1.8	2.3	2.9
4	0.9	2.1	2.6
5	1.8	2.3	2.7
n:	5	5	5
Mean:	NA	2.58	3.2
CV(%):	NA	28.7	33.3

¹ Data from USEPA (1991a).

² Tests performed by Ray Walsh and Wendy Greene, ERL-N, USEPA, Narragansett, RI.

³ SDS concentrations were: 0.9, 1.8, 3.6, 7.3, and 14.5 mg/L.

⁴ NOEC Range: 0.9 - 1.8 mg/L (this represents a difference of one exposure concentration).

⁵ Adults collected in the field.

⁶ For a discussion of the precision of data from chronic toxicity tests see Section 4, Quality Assurance.

TABLE 17. SINGLE-LABORATORY PRECISION OF THE SEA URCHIN, *ARBACIA PUNCTULATA*, FERTILIZATION TEST PERFORMED IN GP2, USING GAMETES FROM ADULTS MAINTAINED IN GP2 ARTIFICIAL SEAWATER AND COPPER (CU) SULFATE AND SODIUM DODECYL SULFATE (SDS) AS REFERENCE TOXICANTS^{1,2,3,4,5}

Test	Cu ($\mu\text{g/L}$)				SDS (mg/L)			
	LC50	CI	NOEC	LOEC	LC50	CI	NOEC	LOEC
1	29.1	27.3-31.1	6.3	12.5	2.1	2.0-2.1	1.3	2.5
2	47.6	44.6-50.8	25.0	50.0	1.8	1.8-1.9	1.3	2.5
3	32.7	29.8-35.8	6.3	12.5	2.2	2.1-2.2	1.3	2.5
4	78.4	73.3-83.9	50.0	100.0	2.3	2.2-2.4	1.3	2.5
5	45.6	41.0-50.7	12.5	25.0	1.8	1.7-2.8	1.3	2.5
Mean	46.7				2.0			
SD	19.5				0.2			
CV	41.8				10.0			

¹ Tests performed by Pamela Comeleo, Science Application International Corp., ERL-N, USEPA, Narragansett, RI.

² All tests were performed using GP2 artificial seawater.

³ Copper concentrations were: 6.25, 12.5, 25.0, 50.0 and 100 $\mu\text{g/L}$.

⁴ SDS concentrations were: 0.6, 1.25, 2.5, 5.0, and 10.0 mg/L. SDS stock (14.645 mg/mL) provided by EMSL, USEPA, Cincinnati, OH.

⁵ For a discussion of the precision of data from chronic toxicity tests see Section 4, Quality Assurance.

TABLE 18. SINGLE-LABORATORY PRECISION OF THE SEA URCHIN, *ARBACIA PUNCTULATA*, FERTILIZATION TEST PERFORMED IN NATURAL SEAWATER, USING GAMETES FROM ADULTS MAINTAINED IN NATURAL SEAWATER AND COPPER (CU) SULFATE AND SODIUM DODECYL SULFATE (SDS) AS REFERENCE TOXICANTS^{1,2,3,4}

Test	Cu ($\mu\text{g/L}$)				SDS (mg/L)			
	LC50	CI	NOEC	LOEC	LC50	CI	NOEC	LOEC
1	28.6	26.7-30.6	6.3	12.5	2.2	2.1-2.2	1.3	2.5
2	13.0	11.9-14.2	6.3	12.5	1.9	1.9-2.0	1.3	2.5
3	67.8	63.2-72.6	6.3	12.5	2.2	2.1-2.3	1.3	2.5
4	36.7	33.9-39.8	< 6.3	6.3	3.3	3.1-3.4	< 0.6	0.6
5	35.6	33.6-37.7	< 6.3	6.3	2.9	2.8-3.1	< 0.6	0.6
Mean	36.3				2.5			
SD	20.0				0.58			
CV	55.1				23.2			

- ¹ Tests performed by Anne Kuhn-Hines, Catherine Sheehan, Glen Modica, and Pamela Comeleo, Science Application International Corp., ERL-N, USEPA, Narragansett, RI.
- ² Copper concentrations were prepared with copper sulfate. Concentrations were 6.25, 12.5, 25.0, 50.0, and 100 $\mu\text{g/L}$.
- ³ SDS concentrations were: 0.6, 1.25, 2.5, 5.0, and 10.0 mg/L. SDS stock (14.64 mg/mL) provided by EMSL, USEPA, Cincinnati, OH.
- ⁴ For a discussion of the precision of data from chronic toxicity tests see Section 4, Quality Assurance.

SECTION 16

TEST METHOD

RED MACROALGA, *CHAMPIA PARVULA*, SEXUAL REPRODUCTION TEST METHOD 1009.0

16.1 SCOPE AND APPLICATION

16.1.1 This method, adapted in part from USEPA (1987f) measures the effects of toxic substances in effluents and receiving water on the sexual reproduction of the marine red macroalga, *Champia parvula*. The method consists of exposing male and female plants to test substances for two days, followed by a 5-7 day recovery period in control medium, during which the cystocarps mature.

16.1.2 Detection limits of the toxicity of an effluent or chemical substance are organism dependent.

16.1.3 Brief excursions in toxicity may not be detected using 24-h composite samples. Also, because of the long sample collection period involved in composite sampling, highly volatile and highly degradable toxicants present in the source may not be detected in the test.

16.1.4 This test is commonly used in one of two forms: (1) a definitive test, consisting of a minimum of five effluent concentrations and a control, and (2) a receiving water test(s), consisting of one or more receiving water concentrations and a control.

16.2 SUMMARY OF METHOD

16.2.1 Sexually mature male and female branches of the red macroalga, *Champia parvula*, are exposed in a static system for 2 d to different concentrations of effluent, or to receiving water, followed by a 5 to 7 day recovery period in control medium. The recovery period allows time for the development of cystocarps resulting from fertilization during the exposure period. The test results are reported as the concentration of the test substance which causes a statistically significant reduction in the number of cystocarps formed.

16.3 INTERFERENCES

16.3.1 Toxic substances may be introduced by contaminants in dilution water, glassware, sample hardware, and testing equipment (see Section 5, Facilities, Equipment, and Supplies).

16.3.2 Improper effluent sampling and handling may adversely affect test results (see Section 8, Effluent and Receiving Water Sampling, Sample Handling, and Sample Preparation for Toxicity Tests).

16.3.3 Adverse effects of high concentrations of suspended and/or dissolved solids, and extremes of pH, may mask the presence of toxic substances.

16.3.4 Pathogenic and/or predatory organisms in the dilution water and effluent may affect test organism survival, and confound test results.

16.4 SAFETY

16.4.1 See Section 3, Safety and Health.

16.5 APPARATUS AND EQUIPMENT

16.5.1 Facilities for holding and acclimating test organisms.

16.5.2 Laboratory red macroalga, *Champia parvula*, culture unit -- see culturing methods below. To test effluent or receiving water toxicity, sufficient numbers of sexually mature male and female plants must be available.

16.5.3 Samplers -- automatic samplers, preferably with sample cooling capability, that can collect a 24-h composite sample of 1 L.

16.5.4 Environmental chamber or equivalent facility with temperature control ($23 \pm 1^\circ\text{C}$).

16.5.5 Water purification system -- Millipore Milli-Q®, deionized water (DI) or equivalent.

16.5.6 Air pump -- for oil-free air supply.

16.5.7 Air lines, and air stones -- for aerating cultures.

16.5.8 Balance -- Analytical, capable of accurately weighing to 0.00001 g.

16.5.9 Reference weights, Class S -- for checking performance of balance.

16.5.10 Meter, pH -- for routine physical and chemical measurements.

16.5.11 Dissecting (stereoscope) microscope -- for counting cystocarps.

16.5.12 Compound microscope -- for examining the condition of plants.

16.5.13 Count register, 2-place -- for recording cystocarp counts.

16.5.14 Rotary shaker -- for incubating exposure chambers (hand-swirling twice a day can be substituted).

16.5.15 Drying oven -- to dry glassware.

16.5.16 Filtering apparatus -- for use with membrane filters (47 mm).

16.5.17 Refractometer -- for determining salinity.

16.5.18 Thermometers, glass or electronic, laboratory grade -- for measuring water temperatures.

- 16.5.19 Thermometers, bulb-thermograph or electronic-chart type -- for continuously recording temperature.
- 16.5.20 Thermometer, National Bureau of Standards Certified (see USEPA Method 170.1, USEPA, 1979b) -- to calibrate laboratory thermometers.
- 16.5.21 Beakers -- Class A, borosilicate glass or non-toxic plasticware, 1000 mL for making test solutions.
- 16.5.22 Erlenmeyer flasks, 250 mL, or 200 mL disposable polystyrene cups, with covers -- for use as exposure chambers.
- 16.5.23 Bottles -- borosilicate glass or disposable polystyrene cups (200-400 mL) for use as recovery vessels.
- 16.5.24 Wash bottles -- for deionized water, for rinsing small glassware and instrument electrodes and probes.
- 16.5.25 Volumetric flasks and graduated cylinders -- Class A, borosilicate glass or non-toxic plastic labware, 10-1000 mL for making test solutions.
- 16.5.26 Micropipettors, digital, 200 and 1000 μ L -- to make dilutions.
- 16.5.27 Pipets, volumetric -- Class A, 1-100 mL.
- 16.5.28 Pipettor, automatic -- adjustable, 1-100 mL.
- 16.5.29 Pipets, serological -- 1-10 mL, graduated.
- 16.5.30 Pipet bulbs and fillers -- PROPIPET®, or equivalent.
- 16.5.31 Forceps, fine-point, stainless steel -- for cutting and handling branch tips.

16.6 REAGENTS AND CONSUMABLE MATERIALS

- 16.6.1 Mature red macroalga, *Champia parvula*, plants -- see Subsection 16.6.14 below.
- 16.6.2 Sample containers -- for sample shipment and storage (see Section 8, Effluent and Receiving Water Sampling, Sample Handling, and Sample Preparation for Toxicity Tests).
- 16.6.3 Petri dishes, polystyrene -- to hold plants for cystocarp counts and to cut branch tips. Other suitable containers may be used.
- 16.6.4 Disposable tips for micropipettors.
- 16.6.5 Aluminum foil, foam stoppers, or other closures -- to cover culture and test flasks.

- 16.6.6 Tape, colored -- for labelling test chambers.
- 16.6.7 Markers, waterproof -- for marking containers, etc.
- 16.6.8 Data sheets (one set per test) -- for data recording.
- 16.6.9 Buffers, pH 4, pH 7, and pH 10 (or as per instructions of instrument manufacturer) for standards and calibration check (see USEPA Method 150.1, USEPA, 1979b).
- 16.6.10 Laboratory quality assurance samples and standards for the above methods.
- 16.6.11 Reference toxicant solutions see Section 4, Quality Assurance.
- 16.6.12 Reagent water -- defined as distilled or deionized water that does not contain substances which are toxic to the test organisms (see Section 5, Facilities, Equipment, and Supplies).
- 16.6.13 Effluent, receiving water, and dilution water -- see Section 7, Dilution Water; and Section 8, Effluent and Receiving Water Sampling, Sample Handling, and Sample Preparation for Toxicity Tests.
- 16.6.13.1 Saline test and dilution water -- the use of natural seawater is recommended for this test. A recipe for the nutrients that must be added to the natural seawater is given in Table 1. The salinity of the test water must be 30‰, and vary no more than $\pm 2\%$ among the replicates. If effluent and receiving water tests are conducted concurrently, the salinity of these tests should be similar.
- 16.6.13.2 The overwhelming majority of industrial and sewage treatment effluents entering marine and estuarine systems contain little or no measurable salts. Therefore, exposure of the red macroalga, *Champia parvula*, to effluents will usually require adjustments in the salinity of the test solutions. Although the red macroalga, *Champia parvula*, cannot be cultured in 100% artificial seawater, 100% artificial seawater can be used during the two day exposure period. This allows 100% effluent to be tested. It is important to maintain a constant salinity across all treatments. The salinity of the effluent can be adjusted by adding hypersaline brine (HSB) prepared from natural seawater (100‰), concentrated (triple strength) salt solution (GP2 described in Table 2), or dry GP2 salts (Table 2), to the effluent to provide a salinity of 30‰. Control solutions should be prepared with the same percentage of natural seawater and at the same salinity (using deionized water adjusted with dry salts, or brine) as used for the effluent dilutions.
- 16.6.13.3 Artificial seawater -- A slightly modified version of the GP2 medium (Spotte, et al, 1984) has been used successfully to perform the red macroalga sexual reproduction test. The preparation of artificial seawater (GP2) is described in Table 2.

TABLE 1. NUTRIENTS TO BE ADDED TO NATURAL SEAWATER AND TO ARTIFICIAL SEAWATER (GP2) DESCRIBED IN TABLE 2. THE CONCENTRATED NUTRIENT STOCK SOLUTION IS AUTOCLAVED FOR 15 MIN (VITAMINS ARE AUTOCLAVED SEPARATELY FOR 2 MIN AND ADDED AFTER THE NUTRIENT STOCK SOLUTION IS AUTOCLAVED). THE pH OF THE SOLUTION IS ADJUSTED TO APPROXIMATELY pH 2 BEFORE AUTOCLAVING TO MINIMIZE THE POSSIBILITY OF PRECIPITATION

	Amount of Reagent Per Liter of Concentrated Nutrient Stock Solution	
	Stock Solution For Culture Medium	Stock Solution For Test Medium
<u>Nutrient Stock Solution</u> ¹		
NaNO ₃	6.35 g	1.58 g
NaH ₂ PO ₄ · H ₂ O	0.64 g	0.16 g
Na ₂ EDTA · 2 H ₂ O	133 mg	--
Na ₃ C ₆ H ₅ O ₇ · 2 H ₂ O	51 mg	12.8 mg
Iron ²	9.75 mL	2.4 mL
Vitamins ³	10 mL	2.5 mL

¹ Add 10 mL of appropriate nutrient stock solution per liter of culture or test medium.

² A stock solution of iron is made that contains 1 mg iron/mL. Ferrous or ferric chloride can be used.

³ A vitamin stock solution is made by dissolving 4.88 g thiamine HCl, 2.5 mg biotin, and 2.5 mg B12 in 500 mL deionized water. Adjust to approximately pH 4 before autoclaving 2 min. It is convenient to subdivide the vitamin stock into 10 mL volumes in test tubes prior to autoclaving.

TABLE 2. REAGENT GRADE CHEMICALS USED IN THE PREPARATION OF GP2 ARTIFICIAL SEAWATER FOR USE IN CONJUNCTION WITH NATURAL SEAWATER FOR THE RED MACROALGA, *CHAMPYA PARVULA*, CULTURING AND TOXICITY TESTING^{1,2,3,4,5,6,7}

Compound	Concentration (g/L)	Amount (g) Required for 20 L
NaCl	21.03	420.6
Na ₂ SO ₄	3.52	70.4
KCl	0.61	12.2
KBr	0.088	1.76
Na ₂ B ₄ O ₇ · 10 H ₂ O	0.034	0.68
MgCl ₂ · 6 H ₂ O	9.50	190.0
CaCl ₂ · 2 H ₂ O	1.32	26.4
SrCl ₂ · 6 H ₂ O	0.02	0.400
NaHCO ₃	0.17	3.40

- ¹ Modified GP2 from Spotte et al. (1984).
- ² The constituent salts and concentrations were taken from USEPA (1990b).
- ³ The original formulation calls for autoclaving anhydrous and hydrated salts separately to avoid precipitation. However, if the sodium bicarbonate is autoclaved separately (dry), all of the other salts can be autoclaved together. Since no nutrients are added until needed, autoclaving is not critical for effluent testing. To minimize microalgal contamination, the artificial seawater should be autoclaved when used for stock cultures. Autoclaving (120°C) should be for a least 10 min for 1-L volumes, and 20 min for 10-to-20 L volumes.
- ⁴ Prepare in 10-L to 20-L batches.
- ⁵ A stock solution of 68 mg/mL sodium bicarbonate is prepared by autoclaving it as a dry powder, and then dissolving it in sterile deionized water. For each liter of GP2, use 2.5 mL of this stock solution.
- ⁶ Effluent salinity adjustment to 30‰ can be made by adding the appropriate amount of dry salts from this formulation, by using a triple-strength brine prepared from this formulation, or by using a 100‰ salinity brine prepared from natural seawater.
- ⁷ Nutrients listed in Table 1 should be added to the artificial seawater in the same concentration described for natural seawater.

16.6.14 TEST ORGANISMS RED MACROALGA, *CHAMPIA PARVULA*

16.6.14.1 Cultures

16.6.14.1.1 Mature plants are illustrated in Figure 1. The adult plant body (thallus) is hollow, septate, and highly branched. New cultures can be propagated asexually from excised branches, making it possible to maintain clonal material indefinitely.

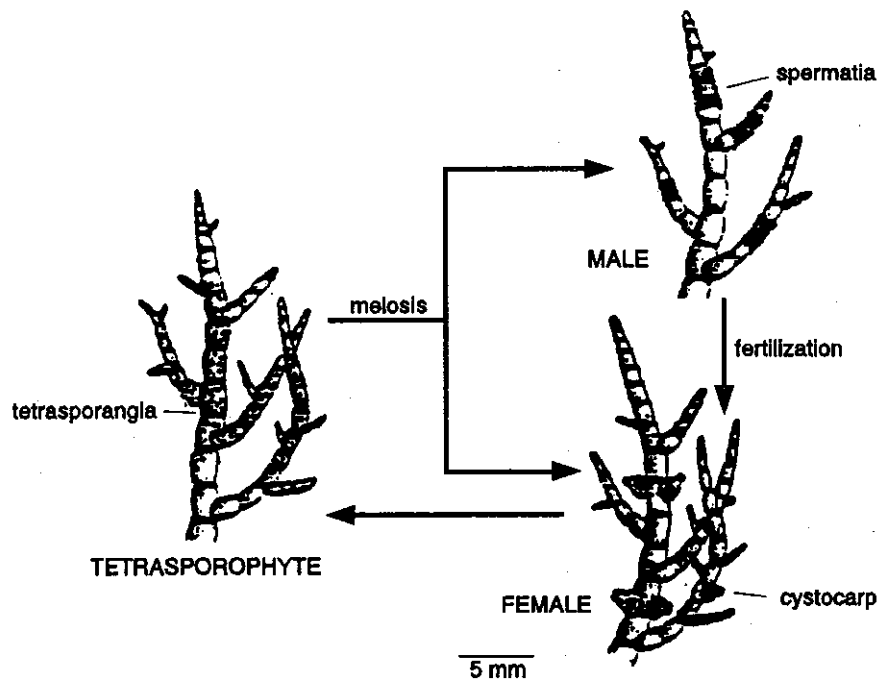

Figure 1. Life history of the red macroalga, *Champia parvula*. Upper left: Size and degree of branching in female branch tips used for toxicity tests. From USEPA (1987f).

16.6.14.1.2 Unialgal stock cultures of both males and females are maintained in separate, aerated 1000 mL Erlenmeyer flasks containing 800 mL of the culture medium. All culture glass must be acid-stripped in 15% HCl and rinsed in deionized water after washing. This is necessary since some detergents can leave a residue that is toxic to the red macroalga, *Champia parvula*. Periodically (at least every 6 months) culture glassware should be baked in a muffle furnace to remove organic material that may build up on its surface. Alternately, a few mL of concentrated sulfuric acid can be rolled around the inside of wet glassware. Caution: the addition of acid to the wet glassware generates heat.

16.6.14.1.3 The culture medium is made from natural seawater to which additional nutrients are added. The nutrients added are listed in Table 1. Almost any nutrient recipe can be used for the red macroalga, *Champia parvula*, cultured in either natural seawater or a 50-50 mixture of natural and artificial seawaters. Healthy, actively growing plants are the goal, not a standard nutrient recipe for cultures.

16.6.14.1.4 Several cultures of both males and females should be maintained simultaneously to keep a constant supply of plant material available. To maintain vigorous growth, initial stock cultures should be started periodically with about twenty 0.5 to 1.0 cm branch tips. Cultures are gently aerated through sterile, cotton-plugged, disposable, polystyrene 1 mL pipettes. Cultures are capped with foam plugs and aluminum foil and illuminated with ca. $75 \mu\text{E}/\text{m}^2/\text{s}$ (500 ft-c) of cool-white fluorescent light on a 16:8 light:dark cycle. Depending on the type of culture chamber or room used, i.e., the degree of reflected light, the light levels may have to be adjusted downward. The temperature is 22 to 24°C and the salinity 28-30‰. Media are changed once a week.

16.6.14.1.5 Prior to use in toxicity tests, stock cultures should be examined to determine their condition. Females can be checked by examining a few branch tips under a compound microscope (100 X or greater). Several trichogynes (reproductive hairs to which the spermatia attach) should be easily seen near the apex (Figure 2).

16.6.14.1.6 Male plants should be visibly producing spermatia. This can be checked by placing some male tissue in a petri dish, holding it against a dark background and looking for the presence of spermatial sori. Mature sori can also be easily identified by looking along the edge of the thallus under a compound microscope (Figures 3 and 4).

16.6.14.1.7 A final, quick way to determine the relative "health" of the male stock culture is to place a portion of a female plant into some of the water from the male culture for a few seconds. Under a compound microscope numerous spermatia should be seen attached to both the sterile hairs and the trichogynes (Figure 5).

16.6.14.2 Culture medium prepared from natural seawater is preferred (Table 1). However, as much as 50% of the natural seawater may be replaced by the artificial seawater (GP2) described in Table 2.

16.6.14.2.1 Seawater for cultures is filtered at least to 0.45 μm to remove most particulates and then autoclaved for 30 minute at 15 psi (120°C). Carbon stripping the seawater may be necessary before autoclaving to enhance its water quality (USEPA, 1990b). This is done by adding 2 g activated carbon per liter of seawater and stirring on a stir plate for 2 h. After stirring filter through a Whatman number 2 filter, then through a 0.45 membrane filter. The culture flasks are capped with aluminum foil and autoclaved dry, for 10 minute. Culture medium is made up by dispensing seawater into sterile flasks and adding the appropriate nutrients from a sterile stock solution.

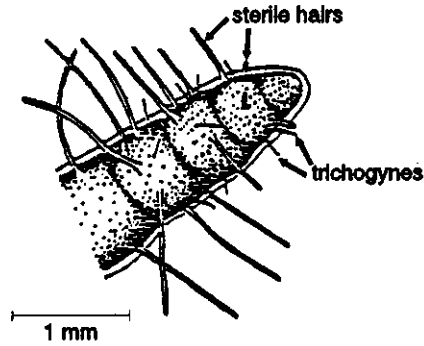

Figure 2. Apex of branch of female plant, showing sterile hairs and reproductive hairs (trichogynes). Sterile hairs are wider and generally much longer than trichogynes, and appear hollow except at the tip. Both types of hairs occur on the entire circumference of the thallus, but are seen easiest at the "edges." Receptive trichogynes occur only near the branch tips. From USEPA (1987f).

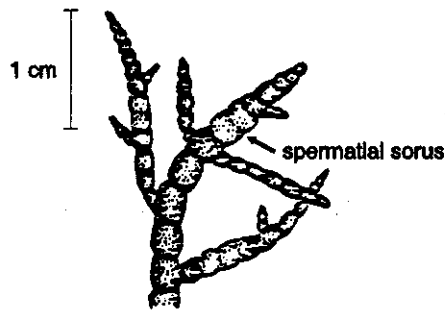

Figure 3. A portion of the male thallus showing spermatial sori. The sori areas are generally slightly thicker and somewhat lighter in color. From USEPA (1987f).

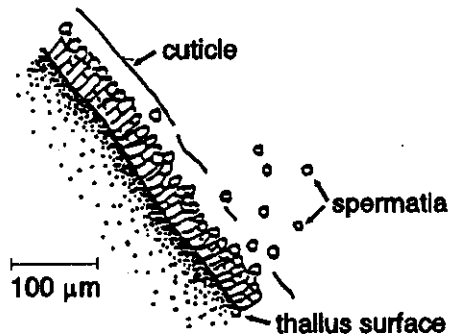

Figure 4. A magnified portion of a spermatial sorus. Note the rows of cells that protrude from the thallus surface. From USEPA (1987f).

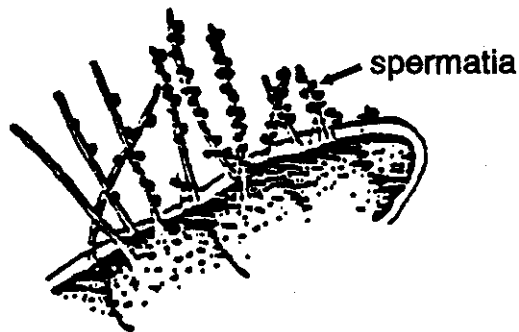

Figure 5. Apex of a branch on a mature female plant that was exposed to spermatia from a male plant. The sterile hairs and trichogynes are covered with spermatia. Note that few or no spermatia are attached to the older hairs (those more than 1 mm from the apex). From USEPA (1987f).

16.6.14.2.2 Alternately, 1-L flasks containing seawater can be autoclaved. Sterilization is used to prevent microalgal contamination, and not to keep cultures bacteria free.

16.7 EFFLUENT AND RECEIVING WATER COLLECTION, PRESERVATION, AND STORAGE

16.7.1 See Section 8, Effluent and Receiving Water Sampling, Sample Handling, and Sample Preparation for Toxicity Tests.

16.8 CALIBRATION AND STANDARDIZATION

16.8.1 See Section 4, Quality Assurance.

16.9 QUALITY CONTROL

16.9.1 See Section 4, Quality Assurance.

16.10 TEST PROCEDURES

16.10.1 TEST SOLUTIONS

16.10.1.1 Receiving Waters

16.10.1.1.1 The sampling point is determined by the objectives of the test. At estuarine and marine sites, samples are usually collected at mid-depth. Receiving water toxicity is determined with samples used directly as collected or with samples passed through a 60 μ m NITEX[®] filter and compared without dilution, against a control. Using four replicate chambers per test, each containing 100 mL, and 400 mL for chemical analysis, would require approximately 800 mL or more of sample per test.

16.10.1.2 Effluents

16.10.1.2.1 The selection of the effluent test concentrations should be based on the objectives of the study. A dilution factor of 0.5 is commonly used. A dilution factor of 0.5 provides precision of $\pm 100\%$, and allows for testing of concentrations between 6.25% and 100% effluent using only five effluent concentrations (6.25%, 12.5%, 25%, 50%, and 100%). Test precision shows little improvement as dilution factors are increased beyond 0.5 and declines rapidly if smaller dilution factors are used. Therefore, USEPA recommends the use of the ≥ 0.5 dilution factor.

16.10.1.2.2 If the effluent is known or suspected to be highly toxic, a lower range of effluent concentrations should be used (such as 25%, 12.5%, 6.25%, 3.12%, and 1.56%).

16.10.1.2.3 The volume of effluent required for the test using a 0.5 dilution series is approximately 1800 mL. Prepare enough test solution at each effluent concentration (approximately 800 mL) to provide 100 mL of test solution for each of four (minimum of three) replicate test chambers and 400 mL for chemical analyses and record data (Figure 6).

16.10.1.2.4 Effluents can be tested at 100%. A 100% concentration of effluent can be achieved if the salinity of the effluent is adjusted to 30‰ by adding the GP2 dry salt formulation described in Table 2.

16.10.1.2.5 Just prior to test initiation (approximately 1 h), the temperature of sufficient quantity of the sample to make the test solutions should be adjusted to the test temperature ($25 \pm 1^\circ\text{C}$) and maintained at the temperature during the addition of dilution water.

16.10.1.2.6 Effluent dilutions should be prepared for all replicated in each treatment in one beaker to minimize variability among the replicates. The test chambers are labelled with the test concentration and replicate number. Dispense into the appropriate effluent dilution chamber.

16.10.1.3 Dilution Water

16.10.1.3.1. The formula for the enrichment for natural seawater is listed in Table 1. Both EDTA and trace metals have been omitted. This formula should be used for the 2-day exposure period, but it is not critical for the recovery period. Since natural seawater quality can vary among laboratories, a more complete nutrient medium (e.g., the addition of EDTA) may result in faster growth (and therefore faster cystocarp development) during the recovery period.

16.10.2 PREPARATION OF PLANTS FOR TEST

16.10.2.1 Once cultures are determined to be usable for toxicity testing (have trichogynes and sori with spermatia), plant cuttings should be prepared for the test, using fine-point forceps, with the plants in a little seawater in a petri dish. For female plants, five cuttings, severed 7-10 mm from the ends of the branch, should be prepared for each treatment chamber. Try to be consistent in the number of branch tips on each cutting. For male plants, one cutting, severed 2.0 to 3.0 cm from the end of the branch, is prepared for each test chamber. Prepare the female cuttings first, to minimize the chances of contaminating them with water containing spermatia from the male stock cultures.

16.10.3. START OF TEST

16.10.3.1 Tests should begin as soon as possible after sample collection, preferably within 24 h. The maximum holding time following retrieval of the sample from the sampling device should not exceed 36 h for off-site toxicity tests unless permission is granted by the permitting authority. In no case should the sample be used in a test more than 72 h after sample collection (see Section 8, Effluent and Receiving Water Sampling, Sample Handling, and Sample Preparation for Toxicity Test, Subsection 8.5.4).

16.10.3.2 Just prior to test initiation (approximately 1 h), the temperature of a sufficient quantity of the sample to make the test solution should be adjusted to the test temperature ($23 \pm 1^\circ\text{C}$) and maintained at that temperature during the addition of dilution water.

16.10.3.3 Label the test chambers with a marking pen. Use of color coded tape to identify each treatment and replicate is helpful. A minimum of five effluent concentrations and a control are used for each effluent test. Each treatment (including controls) should have four (minimum of three) replicates.

16.10.3.4 Randomize the position of test chambers at the beginning of the test.

16.10.3.5 Prepare test solutions and add to the test chambers.

16.10.3.6 Add five female branches and one male branch to each test chamber. The toxicant must be present before the male plant is added.

16.10.3.7 Gently hand swirl the chambers twice a day, or shake continuously at 100 rpm on a rotary shaker.

16.10.3.8 If desired, the media can be changed after 24 h.

16.10.4 LIGHT, PHOTOPERIOD, SALINITY, AND TEMPERATURE

16.10.4.1 The light quality and intensity should be at $75 \mu\text{E}/\text{m}^2/\text{s}$, or 500 foot candles (ft-c) with a photoperiod of 16 h light and 8 h darkness. The water temperature in the test chambers should be maintained at $23 \pm 1^\circ\text{C}$. The test salinity should be in the range of 28 to 32‰. The salinity should vary by no more than $\pm 2\%$ among the chambers on a given day. If effluent and receiving water tests are conducted concurrently, the salinities of these tests should be similar.

16.10.5 DISSOLVED OXYGEN (DO) CONCENTRATION

16.10.5.1 Aeration may affect the toxicity of effluent and should be used only as a last resort to maintain a satisfactory DO. The DO concentrations should be measured on new solutions at the start of the test (Day 0) and should be measured before renewal of the test solution after 24 h. The DO should not fall below 4.0 mg/L (see Section 8, Effluent and Receiving Water Sampling, Sample Handling, and Sample Preparation for Toxicity Tests) If it is necessary to aerate, all treatments and the control should be aerated. The aeration rate should not exceed 100 bubbles/minute, using a pipet with a 1-2 mm orifice, such as a 1mL KIMAX® serological pipet No. 37033, or equivalent. Care should be taken to ensure that turbulence resulting from the aeration does not occur.

16.10.6 OBSERVATIONS DURING THE TEST

16.10.6.1 Routine Chemical and Physical Observations

16.10.6.1.1 DO is measured at the beginning and end of each 24-h exposure period in one test chamber at each concentration and in the control.

16.10.6.1.2 Temperature, pH, and salinity are measured at the end of each 24-h exposure period in one test chamber at each concentration and in the control. Temperature should also be monitored continuously, observed and recorded daily for at least two locations in the environmental control system or the samples. Temperature should be measured in a sufficient number of test chambers at least at the end of the test to determine temperature variation in environmental chamber.

16.10.6.1.3 The pH is measured in the effluent sample each day before new test solutions are made.

16.10.6.1.4 Record all the measurements on the data sheet.

16.10.6.2 Routine Biological Observations

16.10.6.2.1 Protect the red macroalga from unnecessary disturbance during the test by carrying out the daily test observations and solution renewals carefully.

16.10.7 TRANSFER OF PLANTS TO CONTROL WATER AFTER 48 H

16.10.7.1 Label the recovery vessels. These vessels can be almost any type of container or flask containing 100 to 200 mL of seawater and nutrients (see Tables 1 and 2). Smaller volumes can be used, but should be checked to make sure that adequate growth will occur without having to change the medium.

16.10.7.2 With forceps, gently remove the female branches from test chambers and place into recovery bottles. Add aeration tubes and foam stoppers.

16.10.7.3 Place the vessels under cool white light (at the same irradiance as the stock cultures) and aerate for the 5-7 day recovery period. If a shaker is used, do not aerate the solutions (this will enhance the water motion).

16.10.8 TERMINATION OF THE TEST

16.10.8.1 At the end of the recovery period, count the number of cystocarps (Figures 7, 8, and 9) per female and record the data (Figure 10). Cystocarps may be counted by placing females between the inverted halves of a polystyrene petri dish or other suitable containers with a small amount of seawater (to hold the entire plant in one focal plane). Cystocarps can be easily counted under a stereomicroscope, and are distinguished from young branches because they possess an apical opening for spore release (ostiole) and darkly pigmented spores.

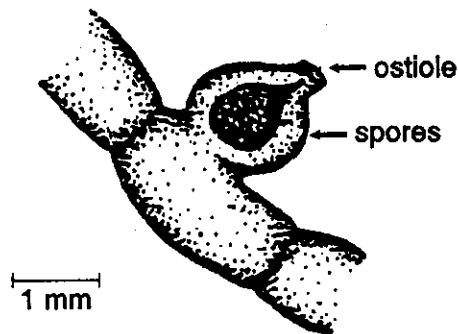

Figure 7. A mature cystocarp. In the controls and lower effluent concentrations, cystocarps often occur in clusters of 10 or 12. From USEPA (1987f).

16.10.8.2 One advantage of this test procedure is that if there is uncertainty about the identification of an immature cystocarp, it is necessary only to aerate the plants a little longer in the recovery bottles. Within 24

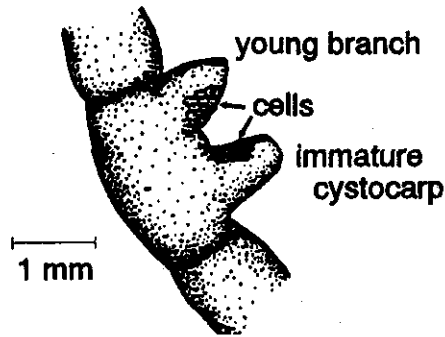

Figure 8. Comparison of a very young branch and an immature cystocarp. Both can have sterile hairs. Trichogynes might or might not be present on a young branch, but are never present on an immature cystocarp. Young branches are more pointed at the apex and are made up of larger cells than immature cystocarps, and never have ostioles. From USEPA (1987f).

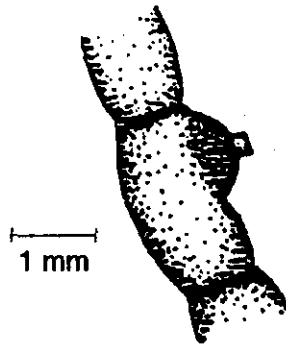

Figure 9. An aborted cystocarp. A new branch will eventually develop at the apex. From USEPA (1987f).

to 48 h, the presumed cystocarp will either look more like a mature cystocarp or a young branch, or will have changed very little, if at all (i.e., an aborted cystocarp). No new cystocarps will form since the males have been removed, and the plants will only get larger. Occasionally, cystocarps will abort, and these should not be included in the counts. Aborted cystocarps are easily identified by their dark pigmentation and, often, by the formation of a new branch at the apex.

16.11 SUMMARY OF TEST CONDITIONS AND TEST ACCEPTABILITY CRITERIA

16.11.1 A summary of test conditions and test acceptability criteria is listed in Table 3.

COLLECTION DATE _____ RECOVERY BEGAN (date) _____

EXPOSURE BEGAN (date) _____ COUNTED (date) _____

EFFLUENT OR TOXICANT _____

TREATMENT (% EFFLUENT, $\mu\text{G/L}$, or RECEIVING WATER SITES)

REPLICATES	CONTROL							
------------	---------	--	--	--	--	--	--	--

A 1								
2								
3								
4								
MEAN								

B 1								
2								
3								
4								
MEAN								

C 1								
2								
3								
4								
MEAN								

OVERALL MEAN								
-----------------	--	--	--	--	--	--	--	--

Temperature _____

Salinity _____

Light _____

Source of Dilution Water _____

Figure 10. Data form for the red macroalga, *Champia parvula*, sexual reproduction test. Cystocarp data sheet. From USEPA (1987f).

TABLE 3. SUMMARY OF TEST CONDITIONS AND TEST ACCEPTABILITY CRITERIA FOR THE RED MACROALGA, *CHAMPIA PARVULA*, SEXUAL REPRODUCTION TEST WITH EFFLUENTS AND RECEIVING WATERS

1. Test type:	Static, non-renewal
2. Salinity:	30‰ (± 2 of the selected test salinity)
3. Temperature:	23 \pm 1°C
4. Photoperiod:	16 h light, 8 h darkness
5. Light intensity:	75 $\mu\text{E}/\text{m}^2/\text{s}$ (500 ft-c)
6. Light source:	Cool-white fluorescent lights
7. Test chamber size:	200 mL polystyrene cups, or 250 mL Erlenmeyer flasks
8. Test solution volume:	100 mL (minimum)
9. No. organisms per test chamber:	5 female branch tips and 1 male plant
10. No. replicate chambers per concentration:	4 (minimum of 3)
11. No. organisms per concentrations:	24 (minimum of 18)
12. Dilution water:	30‰ salinity natural seawater, or a combination of 50% of 30‰ salinity natural seawater and 50% of 30‰ salinity GP2 artificial seawater (see Section 7, Dilution Water)
13. Test concentrations:	Effluents: Minimum of 5 and a control Receiving waters: 100% receiving water or minimum of 5 and a control
14. Test dilution factor:	Effluents: ≥ 0.5 Receiving waters: None or ≥ 0.5

TABLE 3. SUMMARY OF TEST CONDITIONS AND TEST ACCEPTABILITY CRITERIA FOR THE RED MACROALGA, *CHAMPIA PARVULA*, SEXUAL REPRODUCTION TEST WITH EFFLUENTS AND RECEIVING WATERS (CONTINUED)

15. Test duration:	2 day exposure to effluent, followed by 5 to 7-day recovery period in control medium for cystocarp development
16. Endpoints:	Reduction in cystocarp production compared to controls
17. Test acceptability criteria:	80% or greater survival, and an average of 10 cystocarps per plant in controls
18. Sampling requirements:	One sample collected at test initiation, and preferably used within 24 h of the time it is removed from the sampling device (see Section 8, Effluent and Receiving Water Sampling, Sampling Handling, and Sample Preparation for Toxicity Tests, Subsection 8.5.4).
19. Sample volume required:	2 L per test

16.12 ACCEPTABILITY OF TEST RESULTS

16.12.1 The test is acceptable if (1) control survival equals or exceeds 80% and (2) control plants average 10 or more cystocarps per plant.

16.12.2 If plants fragment in the controls or lower exposure concentrations, it may be an indication that they are under stress.

16.13 DATA ANALYSIS

16.13.1 GENERAL

16.13.1.1 Tabulate and summarize the data. A sample set of reproduction data is listed in Table 4.

16.13.1.2 The endpoints of the red macroalga, *Champia parvula*, toxicity test are based on the adverse effects on sexual reproduction as the mean number of cystocarps. The LC50, the IC25, and the IC50 are calculated using point estimation techniques (see Section 9, Chronic Toxicity Test Endpoints and Data Analysis). NOEC and LOEC values are obtained using a hypothesis testing approach, such as Dunnett's Procedure (Dunnett, 1955) or Steel's Many-one Rank Test (Steel, 1959; Miller, 1981) (see Section 9). Separate analyses are performed for the estimation of the NOEC and LOEC endpoints and for the IC25 and IC50. See the Appendices for examples of the manual computations, program listing, and example of data input and program output.

16.13.1.3 The statistical tests described here must be used with a knowledge of the assumptions upon which the tests are contingent. The assistance of a statistician is recommended for analysts who are not proficient in statistics.

16.13.2 EXAMPLE OF ANALYSIS OF THE RED MACROALGA, *CHAMPIA PARVULA*, REPRODUCTION DATA

16.13.2.1 Formal statistical analysis of the data is outlined in Figure 11. The response used in the analysis is the mean number of cystocarps per replicate chamber. Separate analyses are performed for the estimation of the NOEC and LOEC endpoints and for the estimation of the IC25 endpoint and the IC50 endpoint. Concentrations that have exhibited no sexual reproduction (less than 5% of controls) are excluded from the statistical analysis of the NOEC and LOEC, but included in the estimation of the IC endpoints.

16.13.2.2 For the case of equal numbers of replicates across all concentrations and the control, the evaluation of the NOEC and LOEC endpoints is made via a parametric test, Dunnett's Procedure, or a nonparametric test, Steel's Many-one Rank Test. The assumptions of Dunnett's Procedures, normality and homogeneity of variance are formally tested. The test for normality is the Shapiro-Wilk's Test and Bartlett's Test is used to test for homogeneity of variance. Tests for normality and homogeneity of variance are included in Appendix B. If either of these tests fails, the nonparametric test, Steel's Many-one Rank Test is used to determine the NOEC and LOEC endpoints. If the assumptions of Dunnett's Procedure are met, the endpoints are determined by the parametric test.

TABLE 4. DATA FROM THE RED MACROALGA, *CHAMPIA PARVULA*, EFFLUENT TOXICITY TEST. CYSTOCARP COUNTS FOR INDIVIDUAL PLANTS AND MEAN COUNT PER TEST CHAMBER FOR EACH EFFLUENT CONCENTRATION¹

Effluent Concentration (%)	Replicate Test Chamber	Plant					Mean Cystocarp Count
		1	2	3	4	5	
Control	A	19	20	24	7	18	17.60
	B	19	12	21	11	23	17.20
	C	17	25	18	20	16	19.20
0.8	A	10	16	11	12	11	12.00
	B	12	10	6	9	10	9.40
	C	12	9	9	13	8	10.20
1.3	A	10	0	3	5	4	4.40
	B	6	4	4	8	4	5.20
	C	4	4	2	6	4	4.00
2.2	A	1	2	5	4	0	2.40
	B	7	9	9	4	6	7.00
	C	3	2	2	0	0	1.40
3.6	A	2	1	1	5	0	1.80
	B	3	4	6	4	2	3.80
	C	0	4	3	1	3	2.20
6.0	A	1	0	0	0	0	0.20
	B	1	2	1	0	0	0.80
	C	0	4	3	1	3	2.20
10.0	A	0	0	0	0	-	0.00
	B	1	0	0	0	0	0.20
	C	2	1	0	0	0	0.60

¹ Data provided by the ERL-N, USEPA, Narragansett, RI.

**STATISTICAL ANALYSIS OF *CHAMPIA PARVULA*
SEXUAL REPRODUCTION TEST**

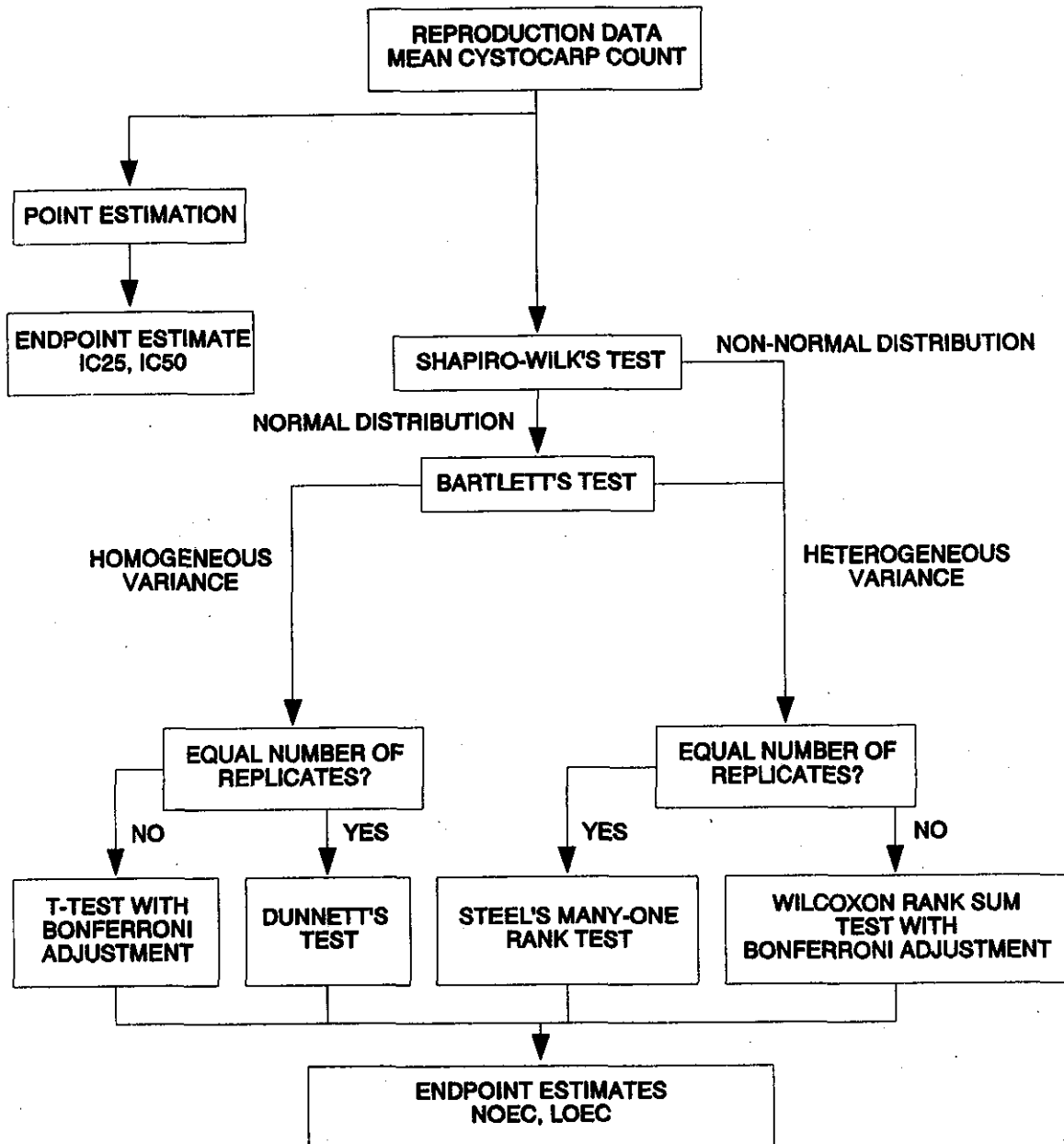

Figure 11. Flowchart for statistical analysis of the red macroalga, *Champia parvula*, data.

16.13.2.3 If unequal numbers of replicates occur among the concentration levels tested there are parametric and nonparametric alternative analyses. The parametric analysis is a t test with the Bonferroni adjustment, (Appendix D). The Wilcoxon Rank Sum Test with the Bonferroni adjustment is the nonparametric alternative.

16.13.2.4 Example of Analysis of Reproduction Data

16.13.2.4.1 In this example, the data, mean and standard deviation of the observations at each concentration including the control are listed in Table 5. The data are plotted in Figure 12. As can be seen from the data in the table, mean reproduction per chamber in the 10% effluent concentration is less than 5% of the control. Therefore the 10% effluent concentration is not included in the subsequent analysis.

TABLE 5. RED MACROALGA, *CHAMPIA PARVULA*, SEXUAL REPRODUCTION DATA

Replicate	Control	Effluent Concentration (%)					
		0.8	1.3	2.2	3.6	6.0	10.0
A	17.60	12.00	4.40	2.40	1.80	0.20	0.00
B	17.20	9.40	5.20	7.00	3.80	0.80	0.20
C	19.20	10.20	4.00	1.40	2.20	2.20	0.60
Mean(\bar{Y}_i)	18.00	10.53	4.53	3.60	2.60	1.07	0.27
S_i^2	1.12	1.77	0.37	8.92	1.12	1.05	0.09
i	1	2	3	4	5	6	7

16.13.2.5 Test for Normality

16.13.2.5.1 The first step of the test for normality is to center the observations by subtracting the mean of all the observations within a concentration from each observation in that concentration. The centered observations are summarized in Table 6.

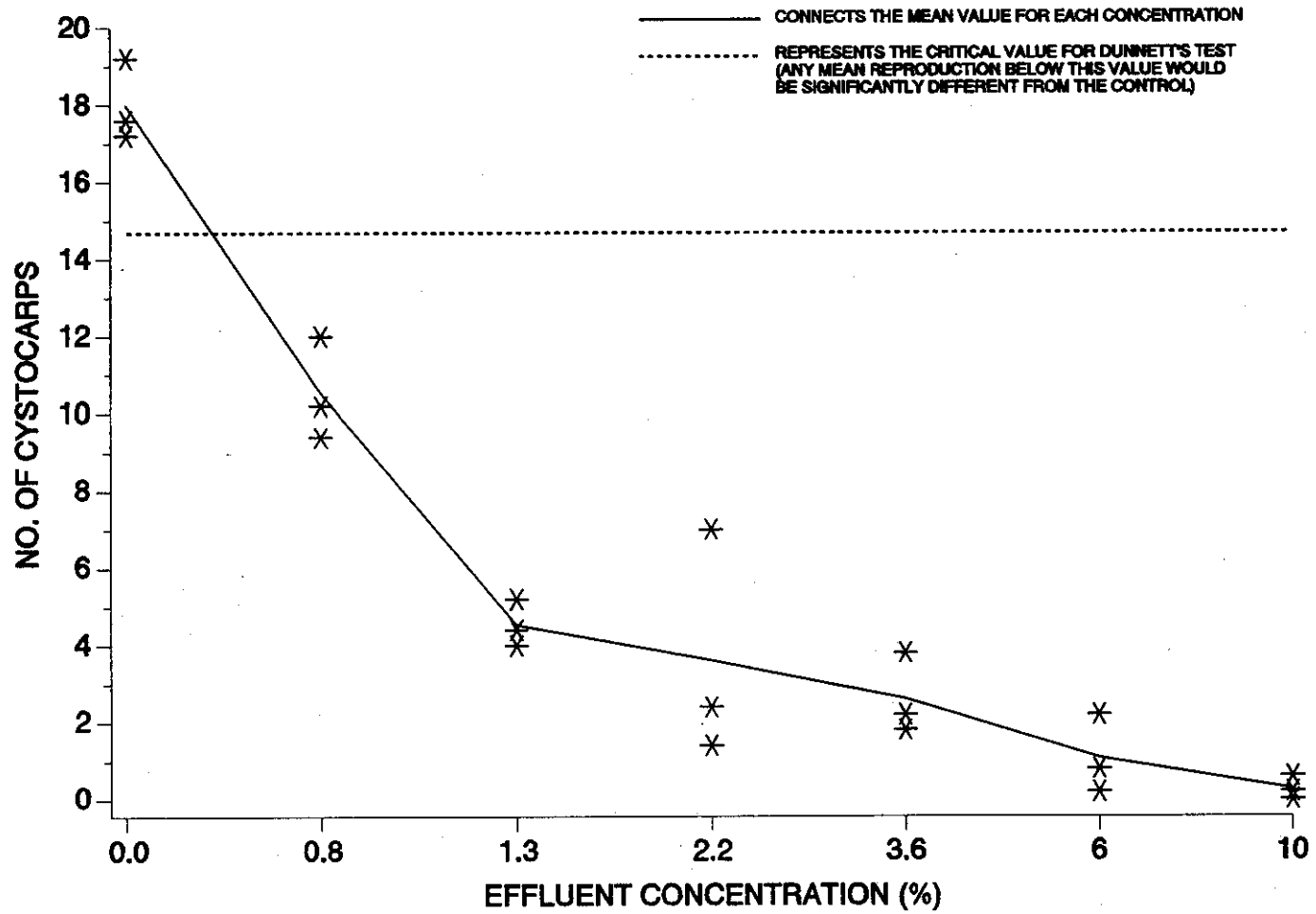

Figure 12. Plot of the number of cystocarps per plant.

TABLE 6. CENTERED OBSERVATIONS FOR SHAPIRO-WILK'S EXAMPLE

Replicate	Control	Effluent Concentration(%)				
		0.8	1.3	2.2	3.6	6.0
A	-0.40	1.47	-0.13	-1.20	-0.80	-0.87
B	-0.80	-1.13	0.67	3.40	1.20	-0.27
C	1.20	-0.33	-0.53	-2.20	-0.40	1.13

16.13.2.5.2 Calculate the denominator, D, of the test statistic:

$$D = \sum_{i=1}^n (X_i - \bar{X})^2$$

Where: X_i = the i th centered observation

\bar{X} = the overall mean of the centered observations

n = the total number of centered observations.

16.13.2.5.3 For this set of data, $n = 18$

$$\bar{X} = \frac{1}{18}(0.01) = 0.00$$

$$D = 28.7201$$

16.13.2.5.4 Order the centered observations from smallest to largest

$$X^{(1)} \leq X^{(2)} \leq \dots \leq X^{(n)}$$

Where $X^{(i)}$ is the i th ordered observation. These ordered observations are listed in Table 7.

TABLE 7. ORDERED CENTERED OBSERVATIONS FOR SHAPIRO-WILK'S EXAMPLE

i	$X^{(i)}$	i	$X^{(i)}$
1	-2.20	10	-0.33
2	-1.20	11	-0.27
3	-1.13	12	-0.13
4	-0.87	13	0.67
5	-0.80	14	1.13
6	-0.80	15	1.20
7	-0.53	16	1.20
8	-0.40	17	1.47
9	-0.40	18	3.40

16.13.2.5.5 From Table 4, Appendix B, for the number of observations, n , obtain the coefficients a_1, a_2, \dots, a_k , where k is $n/2$ if n is even and $(n-1)/2$ if n is odd. For the data in this example, $n = 18$ and $k = 9$. The a_i values are listed in Table 8.

TABLE 8. COEFFICIENTS AND DIFFERENCES FOR SHAPIRO-WILK'S EXAMPLE

i	a_i	$X^{(n-i+1)} - X^{(i)}$	
1	0.4886	5.60	$X^{(18)} - X^{(1)}$
2	0.3253	2.67	$X^{(17)} - X^{(2)}$
3	0.2553	2.33	$X^{(17)} - X^{(3)}$
4	0.2027	2.07	$X^{(15)} - X^{(4)}$
5	0.1587	1.93	$X^{(14)} - X^{(5)}$
6	0.1197	1.47	$X^{(13)} - X^{(6)}$
7	0.0837	0.40	$X^{(12)} - X^{(7)}$
8	0.0496	0.13	$X^{(11)} - X^{(8)}$
9	0.0163	0.07	$X^{(10)} - X^{(9)}$

16.13.2.5.6 Compute the test statistic, W , as follows:

$$W = \frac{1}{D} \left[\sum_{i=1}^k a_i (X^{(n-i+1)} - X^{(i)}) \right]^2$$

The differences $X^{(n-i+1)} - X^{(i)}$ are listed in Table 8. For the data,

$$W = \frac{1}{28.7201} (5.1425)^2 = 0.921$$

16.13.2.5.7 The decision rule for this test is to compare W as calculated in Subsection 16.3.2.2.6 with the critical value found in Table 6, Appendix B. If the computed W is less than the critical value, conclude that the data are not normally distributed. For this example, the critical value at a significance level of 0.01 and 18 observations (n) is 0.858. Since $W = 0.921$ is greater than the critical value, conclude of the test is that the data are normally distributed.

16.13.2.6 Test for Homogeneity of Variance

16.13.2.6.1 The test used to examine whether the variation in mean cystocarp production is the same across all effluent concentrations including the control, is Bartlett's Test (Snedecor and Cochran, 1980). The test statistic is as follows:

$$B = \frac{[(\sum_{i=1}^p V_i) \ln \bar{S}^2 - \sum_{i=1}^p V_i \ln S_i^2]}{C}$$

Where: V_i = degrees of freedom for each effluent concentration and control, $V_i = (n_i - 1)$

p = number of levels of effluent concentration including the control

n_i = the number of replicates for concentration i

\ln = \log_e

i = 1, 2, ..., p where p is the number of concentrations

$$\bar{S}^2 = \frac{(\sum_{i=1}^p V_i S_i^2)}{\sum_{i=1}^p V_i}$$

16.13.2.6.2 For the data in this example (See Table 5) all effluent concentrations including the control have the same number of replicates ($n_i = 3$ for all i). Thus, $V_i = 2$ for all i .

$$C = 1 + [3(p-1)]^{-1} [\sum_{i=1}^p 1/V_i - (\sum_{i=1}^p V_i)^{-1}]$$

16.13.2.6.3 Bartlett's statistic is therefore:

$$\begin{aligned}
 B &= [(12) \ln(2.3917) - 2 \sum_{i=1}^p \ln(S_i^2)] / 1.194 \\
 &= [12(0.8720) - 2(\ln(1.12) + \ln(1.77) + \dots + \ln(1.05))] / 1.1944 \\
 &= (10.4640 - 4.0809) / 1.1944 \\
 &= 5.34
 \end{aligned}$$

16.13.2.6.4 B is approximately distributed as chi-square with $p - 1$ degrees of freedom, when the variances are in fact the same. Therefore, the appropriate critical value for this test, at a significance level of 0.01 with five degrees of freedom, is 15.09. Since $B = 5.34$ is less than the critical value of 15.09, conclude that the variances are not different.

16.13.2.7 Dunnett's Procedure

16.13.2.7.1 To obtain an estimate of the pooled variance for the Dunnett's Procedure, construct an ANOVA table as described in Table 9.

TABLE 9. ANOVA TABLE

Source	df	Sum of Squares (SS)	Mean Square (MS) (SS/df)
Between	$p - 1$	SSB	$S_B^2 = \text{SSB} / (p - 1)$
Within	$N - p$	SSW	$S_W^2 = \text{SSW} / (N - p)$
Total	$N - 1$	SST	

Where: p = number effluent concentrations including the control

N = total number of observations $n_1 + n_2 + \dots + n_p$

n_i = number of observations in concentration i

$$SSB = \sum_{i=1}^P T_i^2/n_i - G^2/N \quad \text{Between Sum of Squares}$$

$$SST = \sum_{i=1}^P \sum_{j=1}^{n_i} Y_{ij}^2 - G^2/N \quad \text{Total Sum of Squares}$$

$$SSW = SST - SSB \quad \text{Within Sum of Squares}$$

G = the grand total of all sample observations, $G = \sum_{i=1}^P T_i$

T_i = the total of the replicate measurements for concentration i

Y_{ij} = the j th observation for concentration i (represents the mean (across plants) number of cystocarps for effluent concentration i in test chamber j)

16.13.2.7.2 For the data in this example:

$$n_1 = n_2 = n_3 = n_4 = n_5 = n_6 = 3$$

$$N = 18$$

$$T_1 = Y_{11} + Y_{12} + Y_{13} = 17.6 + 17.2 + 19.2 = 54$$

$$T_2 = Y_{21} + Y_{22} + Y_{23} = 12.0 + 9.4 + 10.2 = 31.6$$

$$T_3 = Y_{31} + Y_{32} + Y_{33} = 4.4 + 5.2 + 4.0 = 13.6$$

$$T_4 = Y_{41} + Y_{42} + Y_{43} = 2.4 + 7.0 + 1.4 = 10.8$$

$$T_5 = Y_{51} + Y_{52} + Y_{53} = 1.8 + 3.8 + 2.2 = 7.8$$

$$T_6 = Y_{61} + Y_{62} + Y_{63} = 0.2 + 0.8 + 2.2 = 3.2$$

$$G = T_1 + T_2 + T_3 + T_4 + T_5 + T_6 = 121.0$$

$$\begin{aligned} SSB &= \sum_{i=1}^P T_i^2/n_i - G^2/N \\ &= \frac{1}{3} (4287.24) - \frac{(121.0)^2}{18} = 615.69 \end{aligned}$$

$$\begin{aligned} SST &= \sum_{i=1}^P \sum_{j=1}^{n_i} Y_{ij}^2 - G^2/N \\ &= 1457.8 - \frac{(121.0)^2}{18} = 644.41 \end{aligned}$$

$$\begin{aligned} SSW &= SST - SSB \\ &= 644.41 - 615.69 = 28.72 \end{aligned}$$

$$S_B^2 = SSB/(p-1) = 615.69/(6-1) = 123.14$$

$$S_W^2 = SSW/(N-p) = 28.72/(18-6) = 2.39$$

16.13.2.7.3 Summarize these calculations in the ANOVA table (Table 10).

TABLE 10. ANOVA TABLE FOR DUNNETT'S PROCEDURE EXAMPLE

Source	df	Sum of Squares (SS)	Mean Square (MS) (SS/df)
Between	5	615.69	123.14
Within	12	28.72	2.39
Total	17	644.41	

16.13.2.7.4 To perform the individual comparisons, calculate the t statistic for each concentration, and control combination as follows:

$$t_i = \frac{(\bar{Y}_1 - \bar{Y}_i)}{S_W \sqrt{(1/n_1) + (1/n_i)}}$$

Where: \bar{Y}_i = mean number of cystocarps for effluent concentration i

\bar{Y}_1 = mean number of cystocarps for the control

S_W = square root of the within mean square

n_1 = number of replicates for the control

n_i = number of replicates for concentration i

16.13.2.7.5 Table 11 includes the calculated t values for each concentration and control combination. In this example, comparing the 0.8% concentration with the control the calculation is as follows:

$$t_2 = \frac{(18 - 10.53)}{[1.55 \sqrt{(1/3) + (1/3)}]} = 5.90$$

16.13.2.7.6 Since the purpose of this test is to detect a significant reduction in cystocarp production, a one-sided test is appropriate. The critical value for this one-sided test is found in Table 5, Appendix C. For an overall alpha level of 0.05, 12 degrees of freedom for error and five

TABLE 11. CALCULATED T VALUES

Effluent Concentration(%)	i	t _i
0.8	2	5.90
1.3	3	10.64
2.2	4	11.38
3.6	5	12.17
6.0	6	13.38

concentrations (excluding the control) the critical value is 2.50. Mean cystocarp production for concentration i is considered significantly less control if t_i is greater than the critical value. Therefore, mean cystocarp productions for all effluent concentrations in this example have significantly lower cystocarp production than the control. Hence the NOEC is 0.8% and the LOEC is 0.8%.

16.13.2.7.7 To quantify the sensitivity of the test, the minimum significant difference (MSD) that can be statistically detected may be calculated:

$$MSD = d S_w \sqrt{(1/n_1) + (1/n)}$$

Where: d = the critical value for Dunnett's Procedure

S_w = the square root of the within mean square

n = the common number of replicates at each concentration
(this assumes equal replication at each concentration)

n_1 = the number of replicates in the control.

16.13.2.7.8 In this example,

$$\begin{aligned} MSD &= 2.50 (1.55) \sqrt{(1/3) + (1/3)} \\ &= 2.50 (1.55) (.8165) \\ &= 3.16 \end{aligned}$$

16.13.2.7.9 Therefore, for this set of data, the minimum difference that can be detected as statistically significant is 3.16 cystocarps.

16.13.2.7.10 This represents a 17.6% reduction in cystocarp production from the control.

16.13.2.8 Calculation of the ICp

16.13.2.8.1 The sexual reproduction data in Table 5 are utilized in this example. Table 12 contains the mean number of cystocarps for each effluent concentration. As can be seen, the observed means are monotonically non-increasing with respect to concentration. Therefore, it is not necessary to smooth the means prior to calculating the ICp. Refer to Figure 10 for a plot of the response curve.

TABLE 12. RED MACROALGA, *CHAMPIA PARVULA*,
MEAN NUMBER OF CYSTOCARPS

Effluent Conc. (%)	i	Response Means \bar{Y}_i (mg)	Smoothed Means M_i (mg)
Control	1	18.00	18.00
0.8	2	10.53	10.53
1.3	3	4.53	4.53
2.2	4	3.60	3.60
3.6	5	2.60	2.60
6.0	6	1.07	1.07
10.0	7	0.27	0.27

16.13.2.8.2 An IC25 and IC50 can be estimated using the Linear Interpolation Method. A 25% reduction in mean number of cystocarps, compared to the controls, would result in a mean number of 13.50 cystocarps, where $M_i(1-p/100) = 18.00(1-25/100)$. A 50% reduction in mean number of cystocarps, compared to the controls, would result in a mean number of 9.00 cystocarps. Examining the means and their associated concentrations (Table 12), the response, 13.50, is bracketed by $C_1 = 0.0\%$ effluent and $C_2 = 0.8\%$ effluent. The response, 9.00, is bracketed by $C_2 = 0.8\%$ effluent and $C_3 = 1.3\%$ effluent.

16.13.2.8.3 Using the equation from Section 4.2 in Appendix L, the estimate of the IC25 is calculated as follows:

$$ICp = C_j + [M_1(1-p/100) - M_j] \frac{(C_{(j+1)} - C_j)}{(M_{(j+1)} - M_j)}$$

$$IC25 = 0.0 + [18.00(1 - 25/100) - 18.00] \frac{(0.8 - 0.0)}{(10.53 - 18.00)}$$

$$= 0.5\%$$

16.13.2.8.4 Using the equation from Section 4.2 from Appendix L, the estimate of the IC50 is calculated as follows:

$$ICP = C_j + [M_1(1 - P/100) - M_j] \frac{(C_{(j+1)} - C_j)}{(M_{(j+1)} - M_j)}$$

$$IC50 = 0.8 + [18.00(1 - 50/100) - 10.53] \frac{(1.3 - 0.8)}{(4.53 - 10.53)}$$

$$= 0.9 \%$$

16.13.2.8.5 When the ICPIN program was used to analyze this set of data, requesting 80 resamples, the estimate of the IC25 was 0.4821%. The empirical 95.0% confidence interval for the true mean was 0.4013% to 0.6075%. The computer program output for the IC25 for this data set is shown in Figure 13.

16.13.2.8.6 When the ICPIN program was used to analyze this set of data, requesting 80 resamples, the estimate of the IC50 was 0.9278%. The empirical 95.0% confidence interval for the true mean was 0.7893% and 1.0576%. The computer program output for the IC50 for this data set is shown in Figure 14.

16.14 PRECISION AND ACCURACY

16.14.1 PRECISION

16.14.1.1 Single-Laboratory Precision

16.14.1.1.1 The single-laboratory precision data from six tests with copper sulfate (Cu) and six tests with sodium dodecyl sulfate (SDS) are listed in Tables 13-16. The NOECs with Cu differed by only one concentration interval (factor of two), showing good precision. The precision of the first four tests with SDS was somewhat obscured by the choice of toxicant concentrations, but appeared similar to that of Cu in the last two tests. The IC25 and IC50 are indicated in Tables 13-16. The coefficient of variation, based on the IC25 for these two reference toxicants in natural seawater and a mixture of natural seawater and GP2, ranged from 59.6% to 69.0%, and for the IC50, ranged from 22.9% to 43.7%.

16.14.1.2 Multilaboratory Precision

16.14.1.2.1 The multilaboratory precision of the test has not yet been determined.

16.14.2 ACCURACY

16.14.2.1 The accuracy of toxicity tests cannot be determined.

Conc. ID	1	2	3	4	5	6	7
Conc. Tested	0	.8	1.3	2.2	3.6	6	10
Response 1	19	10	10	1	2	1	0
Response 2	20	16	0	2	1	0	0
Response 3	24	11	3	5	1	0	0
Response 4	7	12	5	4	5	0	0
Response 5	18	11	4	0	0	0	1
Response 6	19	12	6	7	3	1	0
Response 7	12	10	4	9	4	2	0
Response 8	21	6	4	9	6	1	0
Response 9	11	9	8	4	4	0	0
Response 10	23	10	4	6	2	0	2
Response 11	17	12	4	3	0	0	1
Response 12	25	9	4	2	4	4	0
Response 13	18	9	2	2	3	3	0
Response 14	20	13	6	0	1	1	0
Response 15	16	8	4	0	3	3	0

*** Inhibition Concentration Percentage Estimate ***

Toxicant/Effluent: effluent

Test Start Date: Test Ending Date:

Test Species: RED MACROALGA, *Champia parvula*

Test Duration:

DATA FILE: champia.icp

OUTPUT FILE: champia.i25

Conc. ID	Number Replicates	Concentration %	Response Means	Std. Dev.	Pooled Response Means
1	15	0.000	18.000	4.928	18.000
2	15	0.800	10.533	2.356	10.533
3	15	1.300	4.533	2.356	4.533
4	15	2.200	3.600	3.066	3.600
5	15	3.600	2.600	1.805	2.600
6	15	6.000	1.067	1.335	1.067
7	15	10.000	0.267	0.594	0.267

The Linear Interpolation Estimate: 0.4821 Entered P Value: 25

Number of Resamplings: 80

The Bootstrap Estimates Mean: 0.4947 Standard Deviation: 0.0616

Original Confidence Limits: Lower: 0.4013 Upper: 0.6075

Resampling time in Seconds: 3.68 Random Seed: 703617166

Figure 13. ICPIN program output for the IC25.

Conc. ID	1	2	3	4	5	6	7
Conc. Tested	0	.8	1.3	2.2	3.6	6	10
Response 1	19	10	10	1	2	1	0
Response 2	20	16	0	2	1	0	0
Response 3	24	11	3	5	1	0	0
Response 4	7	12	5	4	5	0	0
Response 5	18	11	4	0	0	0	1
Response 6	19	12	6	7	3	1	0
Response 7	12	10	4	9	4	2	0
Response 8	21	6	4	9	6	1	0
Response 9	11	9	8	4	4	0	0
Response 10	23	10	4	6	2	0	2
Response 11	17	12	4	3	0	0	1
Response 12	25	9	4	2	4	4	0
Response 13	18	9	2	2	3	3	0
Response 14	20	13	6	0	1	1	0
Response 15	16	8	4	0	3	3	0

*** Inhibition Concentration Percentage Estimate ***

Toxicant/Effluent: effluent

Test Start Date: Test Ending Date:

Test Species: RED MACROALGA, Champia parvula

Test Duration:

DATA FILE: champia.icp

OUTPUT FILE: champia.i50

Conc. ID	Number Replicates	Concentration %	Response Means	Std. Dev.	Pooled Response Means
1	15	0.000	18.000	4.928	18.000
2	15	0.800	10.533	2.356	10.533
3	15	1.300	4.533	2.356	4.533
4	15	2.200	3.600	3.066	3.600
5	15	3.600	2.600	1.805	2.600
6	15	6.000	1.067	1.335	1.067
7	15	10.000	0.267	0.594	0.267

The Linear Interpolation Estimate: 0.9278 Entered P Value: 50

Number of Resamplings: 80

The Bootstrap Estimates Mean: 0.9263 Standard Deviation: 0.0745

Original Confidence Limits: Lower: 0.7893 Upper: 1.0576

Resampling time in Seconds: 3.63 Random Seed: -1255453122

Figure 14. ICPIN program output for the IC50.

TABLE 13. SINGLE-LABORATORY PRECISION OF THE RED MACROALGA, *CHAMPIA PARVULA*, REPRODUCTION TEST PERFORMED IN A 50/50 MIXTURE OF NATURAL SEAWATER AND GP2 ARTIFICIAL SEAWATER, USING GAMETES FROM ADULTS CULTURED IN NATURAL SEAWATER. THE REFERENCE TOXICANT USED WAS COPPER (CU) SULFATE^{1,2,3,4,5}

Test Number	NOEC (µg/L)	IC25 (µg/L)	IC50 (µg/L)
1	1.0	1.67	2.37
2	1.0	1.50	1.99
3	1.0	0.69	1.53
4	1.0	0.98	1.78
5	0.5	0.38	0.76
6	0.5	0.38	0.75
n:	6	6	6
Mean:	NA	0.93	1.5
CV(%):	NA	59.6	43.7

¹ Data from USEPA (1991a).

² Tests performed by Glen Thursby and Mark Tagliabue, ERL-N, USEPA, Narragansett, RI. Tests were conducted at 22°C, in 50/50 GP2 and natural seawater at a salinity of 30‰.

³ Copper concentrations were: 0.5, 1.0, 2.5, 5.0, 7.5, and 1.0 µg/L.

⁴ NOEC Range: 0.5 - 1.0 µg/L (this represents a difference of one exposure concentration).

⁵ For a discussion of the precision of data from chronic toxicity tests see Section 4, Quality Assurance.

TABLE 14. SINGLE-LABORATORY PRECISION OF THE RED MACROALGA, *CHAMPIA PARVULA*, REPRODUCTION TEST PERFORMED IN A 50/50 MIXTURE OF NATURAL SEAWATER AND GP2 ARTIFICIAL SEAWATER, USING GAMETES FROM ADULTS CULTURED IN NATURAL SEAWATER. THE REFERENCE TOXICANT USED WAS SODIUM DODECYL SULFATE (SDS)^{1,2,3,4,5}

Test Number	NOEC (mg/L)	IC25 (mg/L)	IC50 (mg/L)
1	< 0.80	0.6	0.3
2	0.48	0.7	0.6
3	< 0.48	0.4	0.2
4	< 0.48	0.2	0.4
5	0.26	0.2	0.5
6	0.09	0.1	0.3
7	0.16	0.2	0.3
8	0.09	0.1	0.2
9	< 0.29	0.3	0.4
n:	5	9	9
Mean:	NA	0.31	0.36
CV(%):	NA	69.0	37.0

- ¹ Data from USEPA (1991a).
² Tests performed by Glen Thursby and Mark Tagliabue, ERL-N, USEPA, Narragansett, RI. Tests were conducted at 22°C, in 50/50 GP2 and natural seawater at a salinity of 30‰.
³ SDS concentrations for Test 1 were: 0.8, 1.3, 2.2, 3.6, 6.0, and 10.0 mg/L. SDS concentrations for Tests 2, 3, and 4 were: 0.48, 0.8, 1.3, 2.2, 3.6, and 6.0 mg/L. SDS concentrations for Tests 5 and 6 were: 0.09, 0.16, 2.26, 0.43, 0.72, and 1.2 mg/L.
⁴ NOEC Range: 0.09 - 0.48 mg/L (this represents a difference of two exposure concentrations).
⁵ For a discussion of the precision of data from chronic toxicity tests see Section 4, Quality Assurance.

TABLE 15. SINGLE-LABORATORY PRECISION OF THE RED MACROALGA, *CHAMPIA PARVULA*, REPRODUCTION TEST IN NATURAL SEAWATER (30‰ SALINITY).^{1,2,3} THE REFERENCE TOXICANT USED WAS COPPER (CU) SULFATE

Test	Cu ($\mu\text{g/L}$)		
	NOEC	IC25	IC50
1	1.00	2.62	4.02
2	0.50	0.71	1.66
3	0.50	2.83	3.55
4	0.50	0.99	4.15
n:	4	4	4
Mean:	NA	1.79	3.35
CV(%):	NA	61.09	34.45

¹ Data from USEPA (1991a).

² Copper concentrations were 0.5, 1.0, 2.5, 5.0, 7.5, and 10 $\mu\text{g/L}$. Concentrations of Cu were made from a 100 $\mu\text{g/mL}$ CuSO_4 standard obtained from Inorganic Ventures, Inc., Brick, NJ.

³ Prepared by Steven Ward and Glen Thursby, Environmental Research Laboratory, USEPA, Narragansett, RI.

TABLE 16. SINGLE-LABORATORY PRECISION OF THE RED MACROALGA, *CHAMPIA PARVULA*, REPRODUCTION TEST IN NATURAL SEAWATER (30‰ SALINITY). THE REFERENCE TOXICANT USED WAS SODIUM DODECYL SULFATE (SDS)^{1,2,3}

Test	SDS (mg/L)		
	NOEC	IC25	IC50
1	0.60	0.05	0.50
2	0.60	0.48	0.81
3	0.30	0.69	0.89
4	0.15	0.60	0.81
n:	4	4	4
Mean:	NA	0.46	0.75
CV(%):	NA	62.29	22.92

¹ Data from USEPA (1991a).

² SDS concentrations were 0.0375, 0.075, 0.15, 0.03, 0.60, and 1.20 mg/L. Concentrations of SDS were made from a 44.64 ± 3.33 mg/mL standard obtained from the EMSL-USEPA, Cincinnati, OH.

³ Prepared by Steven Ward and Glen Thursby, Environmental Research Laboratory, USEPA, Narragansett, RI.

CITED REFERENCES

- AOAC. 1990. Agricultural chemicals; contaminants; drugs. Vol. 1, Official methods of analysis. 15th edition. Association of Official Analytical Chemists, Arlington, VA.
- APHA. 1992. Part 8010E.4.b. In: Standard methods for the examination of water and wastewater. 18th edition. American Public Health Association, Washington, DC. p. 8-10.
- ASTM. 1993. Standard practice for using brine shrimp nauplii as food for test animals in aquatic toxicology. ASTM E1191-90. American Society for Testing and Materials, Philadelphia, PA.
- Benoit, D.A., F.A. Puglisi, and D.L. Olson. 1982. A fathead minnow, *Pimephales promelas*, early life state toxicity test method evaluation and exposure to four organic chemicals. Environ. Pollut. (Series A) 28:189-197.
- Bengtson, D.A. 1984. Resource partitioning by *Menidia menidia* and *Menidia beryllina* (Osteichthyes: Atherinidae). Mar. Ecol. Prog. Ser. 18:21-32.
- Bengtson, D.A.S., A.D. Beck, S.M. Lussier, D. Migneault, and C.E. Olney. 1984. International study on *Artemia*. XXXI. Nutritional effects in toxicity tests: use of different *Artemia* geographical strains. In: Persoone, G., E. Jaspers, and C. Claus, eds., Ecotoxicological testing for the marine environment, Vol. 2. State Univ. Ghent and Inst. Mar. Sci. Res., Bredene, Belgium. pp. 399-417.
- Bigelow, H.B., and W.C. Schroeder. 1953. Fishes of the Gulf of Maine. U.S. Fish Wildl. Serv., Fish. Bull. 53:1-577.
- Birge, W.J., J.A. Black, and B.A. Ramey. 1981. The reproductive toxicology of aquatic contaminants. Hazard assessments of chemicals, current developments, Vol. 1, Academic Press, Inc., p. 59-114.
- Birge, W.J., and R.A. Cassidy. 1983. Importance of structure-activity relationships in aquatic toxicology. Fundam. Appl. Toxicol. 3:359-368.
- Birge, W.J., J.A. Black, and A.G. Westerman. 1985. Short-term fish and amphibian embryo-larval tests for determining the effects of toxicant stress on early life stages and estimating chronic values for single compounds and complex effluents. Environ. Tox. Chem. (4):807-821.
- Bower, C.E. 1983. The basic marine aquarium. Charles C. Thomas, Publ., Springfield, IL.
- Chernoff, B., J.V. Conner, and C.F. Byran. 1981. Systematics of the *Menidia beryllina* complex (Pisces:Atherinidae) from the Gulf of Mexico and its tributaries. Copeia 2:319-335.

- DeWoskin, R.S. 1984. Good laboratory practice regulations: a comparison. Research Triangle Institute, Research Triangle Park, NC, 63 pp.
- Dunnett, C.W. 1955. Multiple comparison procedure for comparing several treatments with a control. *J. Amer. Statist. Assoc.* 50:1096-1121.
- Emerson, K., R.C. Russo, R.E. Lund, and R.V. Thurston. 1975. Aqueous ammonia equilibrium calculations; effect of pH and temperature. *J. Fish. Res. Bd. Can.* 32(12): 2379-2383.
- FDA. 1978. Good laboratory practices for nonclinical laboratory studies. Part 58, Fed. Reg. 43(247):60013-60020, December 22, 1978.
- Finney, D.J. 1971. Probit analysis. Third Edition. Cambridge Press, NY, NY. 668 pp.
- Gentile, J.H., S.M. Gentile, G. Hoffman, J.F. Heltshe, and N.G. Hairston, Jr. 1983. The effects of chronic mercury exposure on the survival, reproduction and population dynamics of *Mysidopsis bahia*. *Environ. Toxicol. Chem.* 2:61-68.
- Goodman, L.R., D.J. Hansen, D.P. Middaugh, G.M. Cripe, and J.C. Moore. 1985. Method for early life-stage toxicity tests using three atherinid fishes and results with chlorpyrifos. In: Cardwell, R.D., R. Purdy, and R.C. Bahner, eds., Aquatic Toxicology and Hazard Evaluation, ASTM STP 854, American Society for Testing and Materials, Philadelphia, PA. pp. 145-154.
- Heard, R.W. 1982. Guide to the common tidal marsh invertebrates of the northeastern Gulf of Mexico. Publ. No. MASGP-79-004, Mississippi-Alabama Sea Grant Consortium, Ocean Springs, MS.
- Hildebrand, S.F. 1922. Notes on habits and development of eggs and larvae of the silversides *Menidia menidia* and *Menidia beryllina*. *Bull. U. S. Bur. Fish.* 38:113-120.
- Hildebrand, S.F., and W.C. Schroeder. 1928. Fishes of Chesapeake Bay. *Bull. U. S. Fish.* 43(1):366pp.
- Hodges, J.L., Jr., and E.L. Lehmann. 1956. The efficiency of some nonparametric competitors of the t Test. *Ann. Math. Statist.* 31:625-642.
- Horne, J.D., M.A. Swirsky, T.A. Hollister, B.R. Oblad, and J.H. Kennedy. 1983. Aquatic toxicity studies of five priority pollutants, Contract Report, EPA Contract No. 68-01-6201, U. S. Environmental Protection Agency, Washington, DC.
- Jensen, A.L. 1972. Standard error of LC50 and sample size in fish bioassays. *Water. Res.* 6:85-89.

- Johnson, M.S. 1975. Biochemical systematics of the atherinid genus *Menidia*. *Copeia* 4:662-691.
- Kuntz, A. 1916. Notes on the embryology and larval development of five species of teleostean fishes. *Bull. U.S. Bur. Fish.* 34(831):409-429.
- Leger, P., Sorgeloos, P., Millamena, O.M., and Simpson, K.L. 1985. "International Study on *Artemia*. XXV. Factors determining the nutritional effectiveness of *Artemia*: The relative impact of chlorinated hydrocarbons and essential fatty acids in San Francisco Bay and San Pablo Bay *Artemia*." *J. Exp. Mar. Biol. Ecol.*, Vol. 93, 1985. pp. 71-82.
- Leger, P., Bengtson, D.A., Simpson, K.L. and Sorgeloos, P. 1986. "The use and nutritional value of *Artemia* as a food source," M. Barnes (ed.), *Oceanography and Marine Biology Annual Review*, Vol. 24, Aberdeen University Press, Aberdeen, Scotland, 1986, pp. 521-623.
- Lussier, S.M., J.H. Gentile, and J. Walker. 1985. Acute and chronic effects of heavy metals and cyanide on *Mysidopsis bahia* (Crustacea: Mysidacea). *Aquat. Toxicol.* 7:25-35.
- Macek, K.J., and B.H. Sleight. 1977. Utility of toxicity tests with embryos and fry of fish in evaluating hazards associated with the chronic toxicity of chemicals to fishes. *In*: Mayer, F. L., and J. L. Hamelink, eds., *Aquatic Toxicology and Hazard Evaluation*, ASTM STP 634, American Society for Testing and Materials, Philadelphia, PA. pp. 137-146.
- Martin, F.D. and G.E. Drewry. 1978. Development of fishes of the Mid-Atlantic Bight. An atlas of eggs, larval, and juvenile stages. Biological Service Program, Fish and Wildlife Service, U.S. Department of the Interior, Washington DC. FWS/OBS-78/12.
- McKim, J.M. 1977. Evaluation of tests with the early life stages of fish for predicting long-term toxicity. *J. Fish. Res. Bd. Can.* 34:1148-1154.
- Middaugh, D.P., and T. Takita. 1983. Tidal and diurnal spawning cues in the Atlantic Silverside, *Menidia menidia*. *Environ. Biol. Fish.* 8(2):97-104.
- Middaugh, D.P., and M.J. Hemmer. 1984. Spawning of the tidewater silverside, *Menidia peninsulae* (Goode and Bean) in response to tidal and lighting schedules in the laboratory. *Estuaries* 7:137-146.
- Middaugh, D.P., M.J. Hemmer, and Y. Lamadrid-Rose. 1986. Laboratory spawning cues in *Menidia beryllina* and *M. peninsulae* (Pisces: Atherinidae) with notes on survival and growth of larvae at different salinities. *Environ. Biol. Fish.* 15(2):107-117.
- Miller, R.G. 1981. Simultaneous statistical inference. Springer-Verlag, New York. 299 pp.

- Mount, D.I., and C.E. Stephan. 1967. A method for establishing acceptable toxicant limits for fish - Malathion and 2,4-D. *Trans. Am. Fish. Soc.* 96: 185-193.
- Nacci, D., and E. Jackim. 1985. Rapid aquatic toxicity assay using incorporation of tritiated-thymidine into sea urchin, *Arbacia punctulata*, embryo. In: Bahner, R.C., and D.J. Hansen. eds., *Aquatic Toxicology and Hazard Assessment: Eighth Symposium*. STP 891. American Society for Testing and Materials, Philadelphia, PA. pp. 382-393.
- Norberg, T.J., and D.I. Mount. 1983. A seven-day larval growth test. Presented at the Annual Meeting, Society of Environmental Toxicology and Chemistry, November 6-9, 1983, Arlington, VA.
- Norberg, T.J., and D.I. Mount. 1985. A new fathead minnow (*Pimephales promelas*) subchronic toxicity test. *Environ. Toxicol. Chem.* 4(5):711-718.
- Norberg-King, T.J. 1991. Calculations of ICp values of IC15, IC20, IC25, IC30, and IC50 for Appendix A of the revised technical support document. Memorandum to M. Heber, USEPA, Washington, DC.
- Price, W. W. 1978. Occurrence of *Mysidopsis almyra* Bowman, *M. bahia* Molenock, and *Bowmaniella brasiliensis* Bacescu (Crustacea, Mysidacea) from the eastern coast of Mexico. *Gulf Res. Repts.* 6:173-175.
- Price, W.W. 1982. Key to the shallow water Mysidacea of the Texas coast with notes on their ecology. *Hydrobiol.* 93(1/2):9-21.
- Renfro, W.C. 1960. Salinity relations of some fishes in the Aransas River. *Tulane Stud. Zool.* 8:83-91.
- Richards, F.A., and N. Corwin. 1956. Some oceanographic applications of recent determinations of the solubility of oxygen in seawater. *Limnol. Oceanogr.* 1(4):263-267.
- Rodgers, J.H., Jr., P.B. Dorn, T. Duke, R. Parrish, and B. Venables (rapporteur). 1986. *Mysidopsis* sp.: life history and culture. A report from a workshop held at Gulf Breeze, Florida, October 15-16, 1986. American Petroleum Institute, Washington, DC.
- Simmons, E.G. 1957. Ecological survey of the Upper Laguna Madre of Texas. *Publ. Inst. Mar. Sci.* 4(2):156-200.
- Smith, B.A. 1971. An ecological study of the Delaware River in the vicinity of Artificial Island. Part V. The fish of four low-salinity tidal tributaries of the Delaware River estuary. Progress Report to Public Service Electric and Gas Co. Ichthyological Assoc. Ithaca, NY. 291 pp.
- Snedecor, G.W., and W.G. Cochran. 1980. *Statistical Methods*. Seventh edition. Iowa State University Press, Ames, IA. 593 pp.

- Spotte, S. 1973. Marine aquarium keeping. John Wiley and Sons, NY, NY.
- Spotte, S., G. Adams, and P.M. Bubucis. 1984. GP2 as an artificial seawater for culture or maintenance of marine organisms. Zool. Biol. 3:229-240.
- Steel, R.G. 1959. A multiple comparison rank sum test: treatments versus control. Biometrics 15:560-572.
- Stuck, K.C., H.M. Perry, and R.W. Heard. 1979a. An annotated key to the Mysidacea of the North Central Gulf of Mexico. Gulf Res. Rept. 6(3):225-238.
- Stuck, K.C., H.M. Perry, and R.W. Heard. 1979b. Records and range extensions of Mysidacea from coastal and shelf water of the Eastern Gulf of Mexico. Gulf Res. Rept. 6(3):239-248.
- Tagatz, M.E., and D.L. Dudley. 1961. Seasonal occurrence of marine fishes in four shore habitats near Beaufort, N.C., 1957-1960. U.S. Fish. Wildl. Serv. Sc. Rept. Fish. 390. 19 pp.
- Taylor, J.K. 1987. Quality assurance of chemical measurements. Lewis Publ., Inc., Chelsea, MI.
- Thurston, R.V., R.C. Russo, and K. Emerson. 1974. Aqueous ammonia equilibrium calculations. Tech. Rep. No. 741. Fisheries Bioassay Laboratory, Montana State University, Bozeman, MT. 18 pp.
- USDA. 1989. Methods which detect multiple residues. Vol. 1. Pesticide analysis manual. U. S. Department of Health and Human Services, Washington D.C.
- USEPA. 1973. Biological field and laboratory methods for measuring the quality of surface waters and effluents. C. I. Weber (ed.). U. S. Environmental Protection Agency, Methods Development and Quality Assurance Research Laboratory, Cincinnati, OH 45268. EPA 600/4-73-001.
- USEPA. 1975. Methods for acute toxicity tests with fish, macroinvertebrates, and amphibians. Environmental Research Laboratory, U. S. Environmental Protection Agency, Duluth, MN 55804. EPA/660/3-75/009.
- USEPA. 1978. Life-cycle toxicity test using sheepshead minnows (*Cyprinodon variegatus*). Hansen, D.J., P.R. Parrish, S.C. Schimmel, and L.R. Goodman. In: Bioassay procedures for the ocean disposal permit program, U. S. Environmental Protection Agency, Environmental Research Laboratory, Gulf Breeze, FL 32561. EPA/600/9-78/010. pp. 109-117.
- USEPA. 1979a. Handbook for analytical quality control in water and wastewater laboratories. U. S. Environmental Protection Agency, Environmental Monitoring and Support Laboratory, Cincinnati, OH 45268. EPA/600/4-79/019.

- USEPA. 1979b. Methods for chemical analysis of water and wastes. Environmental Monitoring and Support Laboratory, U. S. Environmental Protection Agency, Cincinnati, OH 45268. EPA-600/4-79/020, revised March 1983.
- USEPA. 1979c. Interim NPDES compliance biomonitoring inspection manual. Office of Water Enforcement, U. S. Environmental Protection Agency, Washington, DC 20460. (MCD-62).
- USEPA. 1979d. Good laboratory practice standards for health effects. Paragraph 772.110-1, Part 772 - Standards for development of test data. Fed. Reg. 44:27362-27375, May 9, 1979.
- USEPA. 1980a. Appendix B - Guidelines for Deriving Water Quality Criteria for the Protection of Aquatic Life and Its Uses. Federal Register, Vol. 45, No. 231, Friday, November 28, 1980.
- USEPA. 1980b. Proposed good laboratory practice guidelines for toxicity testing. Paragraph 163.60-6. Fed. Reg. 45:26377-26382, April 18, 1980.
- USEPA. 1980c. Physical, chemical, persistence, and ecological effects testing; good laboratory practice standards (proposed rule). 40 CFR 772, Fed. Reg. 45:77353-77365, November 21, 1980.
- USEPA. 1981. *In situ* acute/chronic toxicological monitoring of industrial effluents for the NPDES biomonitoring program using fish and amphibian embryo/larval stages as test organisms. Birge, W.J., and J.A. Black. Office of Water Enforcement and Permits, U. S. Environmental Protection Agency, Washington, DC 20460. OWEP-82-001.
- USEPA. 1982. Methods for organic chemical analysis of municipal and industrial wastewater. Environmental Monitoring and Support Laboratory, U. S. Environmental Protection Agency, Cincinnati, OH 45268. EPA/600/4-82/057.
- USEPA. 1983. Guidelines and format for EMSL-Cincinnati methods. Kopp, J.F. Environmental Monitoring and Support Laboratory, U. S. Environmental Protection Agency, Cincinnati, OH 45268. EPA/600/8-83/020.
- USEPA. 1984. Effluent and ambient toxicity testing and instream community response on the Ottawa River, Lima, Ohio. Mount, D.I., N.A. Thomas, T.J. Norberg, M. T. Barbour, T.H. Roush, and W.F. Brandes. Environmental Research Laboratory, U. S. Environmental Protection Agency, Duluth, MN 55804. EPA/600/3-84/080.
- USEPA. 1985a. Methods for measuring the acute toxicity of effluents to freshwater and marine organisms. Third Edition. Peltier, W., and C.I. Weber. eds. Environmental Monitoring and Support Laboratory, U. S. Environmental Protection Agency, Cincinnati, OH 45268. EPA/600/4-85/013.

- USEPA. 1985b. Short-term methods for estimating the chronic toxicity of effluents and receiving waters to freshwater organisms. Horning, W.B., and C.I. Weber (eds). Second edition. Environmental Monitoring and Support Laboratory, U. S. Environmental Protection Agency, Cincinnati, OH 45268. EPA/600/4-85/014.
- USEPA. 1985c. Validity of effluent and ambient toxicity tests for predicting biological impact, Scippo Creek, Circleville, Ohio. Mount, D.I., and T.J. Norberg-King (eds.). Environmental Research Laboratory, U. S. Environmental Protection Agency, Duluth, MN 55804. EPA/600/3-85/044.
- USEPA. 1985d. Validity of effluent and ambient toxicity testing for predicting biological impact on Five Mile Creek, Birmingham, Alabama. Mount, D.I., A.E. Steen, and T.J. Norberg-King (eds.). Environmental Research Laboratory, U. S. Environmental Protection Agency, Duluth, MN 55804. EPA/600/8-85/015.
- USEPA. 1985e. Validity of effluent and ambient toxicity tests for predicting biological impact, Ohio River, near Wheeling, West Virginia. Mount, D.I., A. E. Steen, and T.J. Norberg-King (eds.). Environmental Research Laboratory, U. S. Environmental Protection Agency, Duluth, MN 55804. EPA/600/3-85/071.
- USEPA. 1986a. Validity of effluent and ambient toxicity tests for predicting biological impact, Back River, Baltimore Harbor, Maryland. Mount, D.I., A. E. Steen, and T. Norberg-King (eds.). Environmental Research Laboratory, U. S. Environmental Protection Agency, Duluth, MN 55804. EPA/600/8-86/001.
- USEPA. 1986b. Validity of effluent and ambient toxicity tests for predicting biological impact, Skeleton Creek, Enid, Oklahoma. Norberg, T.J., and D.I. Mount (eds.). Environmental Research Laboratory, U. S. Environmental Protection Agency, Duluth, MN 55804. EPA/600/8-86/002.
- USEPA. 1986c. Validity of effluent and ambient toxicity tests for predicting biological impact, Kanawha River, Charleston, West Virginia. Mount, D.I., and T. Norberg-King (eds.). Environmental Research Laboratory, U. S. Environmental Protection Agency, Duluth, MN 55804. EPA/600/3-86/006.
- USEPA. 1986d. Validity of effluent and ambient toxicity tests for predicting biological impact, Naugatuck River, Connecticut. Mount, D.I., T. Norberg-King, and A.E. Steen (eds.). Environmental Research Laboratory, U. S. Environmental Protection Agency, Duluth, MN. 55804 EPA/600/8-86/005.
- USEPA. 1986e. Occupational health and safety manual. Office of Administration, U. S. Environmental Protection Agency, Washington, DC 20460.

- USEPA. 1987a. Users guide to the conduct and interpretation of complex effluent toxicity tests at estuarine/marine sites. Schimmel, S.C., ed. Environmental Research Laboratory, U. S. Environmental Protection Agency, Narragansett, RI 02882. Contribution No. 796., 265 pp.
- USEPA. 1987b. Guidance manual for conducting complex effluent and receiving water larval fish growth-survival studies with the sheepshead minnow (*Cyprinodon variegatus*). Contribution No. X104. Hughes, M.M., M.A. Heber, S.C. Schimmel, and W.J. Berry. In: Schimmel, S.C., ed. Users guide to the conduct and interpretation of complex effluent toxicity tests at estuarine/marine sites. Environmental Research Laboratory, U. S. Environmental Protection Agency, Narragansett, RI 02882. Contribution No. 796., 265 pp.
- USEPA. 1987c. Guidance manual for rapid chronic toxicity tests on effluents and receiving waters with larval inland silversides (*Menidia beryllina*). Contribution No. 792. Heber, M.A., M.M. Hughes, S.C. Schimmel, and D.A. Bengtson. In: Schimmel, S.C. ed., Users guide to the conduct and interpretation of complex effluent toxicity tests at estuarine/marine sites. Environmental Research Laboratory, U. S. Environmental Protection Agency, Narragansett, RI 02882. Contribution No. 796., 265 pp.
- USEPA. 1987d. Guidance manual for conducting seven day mysid survival/growth/reproduction study using the estuarine mysid, *Mysidopsis bahia*. Contribution No. X106. Lussier, S.M., A. Kuhn, and J. Sewall. In: Schimmel, S. C., ed. Users guide to the conduct and interpretation of complex effluent toxicity tests at estuarine/marine sites. Environmental Research Laboratory, U. S. Environmental Protection Agency, Narragansett, RI 02882. Contribution No. 796., 265 pp.
- USEPA. 1987e. Guidance manual for conducting sperm cell tests with the sea urchin, *Arbacia punctulata*, for use in testing complex effluents. Nacci, D., R. Walsh, and E. Jackim. Contribution No. X105. In: Schimmel, S.C., ed. Users guide to the conduct and interpretation of complex effluent toxicity tests at estuarine/marine site. Environmental Research Laboratory, U. S. Environmental Protection Agency, Narragansett, RI 02882. Contribution No. 796., 265 pp.
- USEPA. 1987f. Guidance manual for conducting sexual reproduction test with the marine macroalga *Champia parvula* for use in testing complex effluents. Contribution No. X103. Thursby, G.B., and R.L. Steele. In: Schimmel, S. C., ed. Users guide to the conduct and interpretation of complex effluent toxicity tests at estuarine/marine sites. Environmental Research Laboratory, U. S. Environmental Protection Agency, Narragansett, RI 02882. Contribution No. 796., 265 pp.

- USEPA. 1987g. Methods for spawning, culturing and conducting toxicity-tests with early life stages of four antherinid fishes: the inland silverside, *Menidia beryllina*, Atlantic silverside, *M. menidia*, tidewater silverside, *M. peninsulae*, and California grunion, *Leuresthes tenuis*. Middaugh, D.P., M.J. Hemmer, and L.R. Goodman. Office of Research and Development, U. S. Environmental Protection Agency, Washington, DC 20460. EPA/600/8-87/004.
- USEPA. 1988a. Short-term methods for estimating the chronic toxicity of effluents and receiving waters to marine and estuarine organisms. Weber, C.I., W.B. Horning, II, D.J. Klemm, T.W. Neiheisel, P.A. Lewis, E.L. Robinson, J. Menkedick, and F. Kessler (eds.). Environmental Monitoring and Support Laboratory, U. S. Environmental Protection Agency, Cincinnati, OH 45268. EPA/600/4-87/028.
- USEPA. 1988b. NPDES compliance inspection manual. Office of Water Enforcement and Permits (EN-338), U. S. Environmental Protection Agency, Washington, DC 20460.
- USEPA. 1988c. Methods for aquatic toxicity identification evaluations: Phase I toxicity characterization procedures. D.I. Mount and L. Anderson-Carnahan. Environmental Research Laboratory, U. S. Environmental Protection Agency, Duluth, MN 55804. EPA-600/3-88/034.
- USEPA. 1988d. An interpolation estimate for chronic toxicity: The ICp approach. Norberg-King, T.J. Technical Report 05-88, National Effluent Toxicity Assessment Center, Environmental Research Laboratory, U. S. Environmental Protection Agency, Duluth, MN 55804.
- USEPA. 1989a. Short-term methods for estimating the chronic toxicity of effluents and receiving waters to freshwater organisms. Second Edition. Weber, C.I., W.H. Peltier, T.J. Norberg-King, W.B. Horning, II, F.A. Kessler, J.R. Menkedick, T.W. Neiheisel, P.A. Lewis, D.J. Klemm, Q.H. Pickering, E.L. Robinson, J.M. Lazorchak, L.J. Wymer, and R.W. Freyberg (eds.). Environmental Monitoring Systems Laboratory, U. S. Environmental Protection Agency, Cincinnati, OH 45268. EPA/600/4-89/001.
- USEPA. 1989b. Toxicity reduction evaluation protocol for municipal wastewater treatment plants. J.A. Botts, J.W. Braswell, J. Zyman, W.L. Goodfellow, and S.B. Moore (eds.). Risk Reduction Engineering Laboratory, U. S. Environmental Protection Agency, Cincinnati, OH 45268. EPA/600/2-88/062.
- USEPA. 1989c. Generalized methodology for conducting industrial toxicity reduction evaluations (TREs). J.A. Fava, D. Lindsay, W.H. Clement, R. Clark, G.M. DeGraeve, J.D. Cooney, S. Hansen, W. Rue, S. Moore, and P. Lankford (eds.). Risk Reduction Engineering Laboratory, U. S. Environmental Protection Agency, Cincinnati, OH 45268. EPA/600/2-88/070.

- USEPA. 1989d. Methods for aquatic toxicity identification evaluations: Phase II toxicity identification procedures. D.I. Mount, and L. Anderson-Carnahan. Environmental Research Laboratory, U. S. Environmental Protection Agency, Duluth, MN 55804. EPA-600/3-88/035.
- USEPA. 1989e. Methods for aquatic toxicity identification evaluations: Phase III, toxicity confirmation procedures. D.I. Mount. Environmental Research Laboratory, U. S. Environmental Protection Agency, Duluth, MN 55804. EPA-600/3-88/036.
- USEPA. 1990a. Macroinvertebrate field and laboratory methods for evaluating the biological integrity of surface waters. Klemm, D.J., P.A. Lewis, F. Fulk, and J.M. Lazorchak. Environmental Monitoring Systems Laboratory, U. S. Environmental Protection Agency, Cincinnati, OH 45268. EPA/600/4-90/030.
- USEPA. 1990b. Supplemental methods and status reports for short-term saltwater toxicity tests. G. Morrison and G. Chapman. ERL Contrib. No. 1199. Environmental Research Laboratory, U. S. Environmental Protection Agency, Narragansett, RI 02882. 127 pp.
- USEPA. 1991a. Technical support document for water quality-based toxic controls. Office of Water Enforcement and Permits and Office of Water Regulations and Standards, U. S. Environmental Protection Agency, Washington, DC 20460. EPA/505/2-90-001.
- USEPA. 1991b. Methods for aquatic toxicity identification evaluations: Phase I, toxicity characterization procedures. 2nd ed., T. Norberg-King, D.I. Mount, E. Durhan, G. Ankley, L. Burkhard, J. Amato, M. Ludasewycz, M. Schubauer-Berigan, and L. Anderson-Carnahan (eds.). Environmental Research Laboratory, U. S. Environmental Protection Agency, Duluth, MN 55804. EPA/600/6-91/003.
- USEPA. 1991c. Manual for the evaluation of laboratories performing aquatic toxicity tests. Klemm, D.J., L.B. Lobring, and W.H. Horning. Environmental Monitoring Systems Laboratory, U. S. Environmental Protection Agency, Cincinnati, OH 45268. EPA/600/4-90/031.
- USEPA. 1992. Toxicity identification evaluation: Characterization of chronically toxic effluents: Phase I. T.J. Norberg-King, D.I. Mount, J.R. Amato, D.A. Jensen, and J.A. Thompson. Environmental Research Laboratory, U. S. Environmental Protection Agency, Duluth, MN 55804. EPA-600/6-91/005F.
- USEPA. 1993a. Methods for measuring the acute toxicity of effluents and receiving waters to freshwater and marine organisms. Fourth Edition. Weber, C.I. (ed.). Environmental Monitoring Systems Laboratory, U. S. Environmental Protection Agency, Cincinnati, OH 45268. EPA/600/4-90/027F.

- USEPA. 1993b. Short-term methods for estimating the chronic toxicity of effluents and surface waters to freshwater organisms. Third edition. Lewis, P.A., D.J. Klemm, and J.M. Lazorchak (eds.). Environmental Monitoring Systems Laboratory, U. S. Environmental Protection Agency, Cincinnati, OH 45268. EPA/600/4-91/002.
- USEPA. 1993c. Fish field and laboratory methods for evaluating the biological integrity of surface waters. Klemm, D.J., Q.J. Stober, and J.M. Lazorchak. Environmental Monitoring Systems Laboratory, U.S. Environmental Protection Agency, Cincinnati, OH 45268. EPA/600/R-92/111.
- Vanhaecke, P., Steyaert, H. and Sorgeloos, P. 1980. "International Study on *Artemia*. III. The use of Coulter Counter equipment for the biometrical analysis of *Artemia* cysts. Methodology and Mathematics," In: G. Persoone, P. Sorgeloos, O. Roels, and E. Jaspers (eds.), The Brine Shrimp *Artemia*, Vol. 1, Morphology, Genetics, Radiobiology, Toxicology. Universal Press, Wetteren, Belgium, 1980, pp. 107-115.
- Vanhaecke, P. and Sorgeloos, P. 1980. "International Study on *Artemia*. IV. The biometrics of *Artemia* strains from different geographical origin." In: G. Persoone, P. Sorgeloos, O. Roels and E. Jaspers (eds.), The Brine Shrimp *Artemia*, Vol. 3, Ecology, Culturing Use in Aquaculture, Universal Press, Wetteren, Belgium. pp. 393-405.
- Walters, D.B., and C.W. Jameson. 1984. Health and safety for toxicity testing. Butterworth Publ., Woburn, MA.
- Ward, G.S., and P.R. Parrish. 1980. Evaluation of early life stage toxicity tests with embryos and juveniles of sheepshead minnows. In: J. G. Eaton, P.R. Parrish and A.C. Hendricks, Aquatic Toxicology, ASTM STP 707, American Society for Testing and Materials, Philadelphia, PA. p. 243-247.
- Woltering, D.M. 1984. The growth response in fish chronic and early life stage toxicity tests: A critical review. *Aquat. Toxicol.* 5:1-21.

BIBLIOGRAPHY

- Anderson, J.W., J.M. Neff, B.A. Cox, H.E. Tatem, and G.H. Hightower. 1974. Characteristics of dispersions and water-soluble extracts of crude and refined oils and their toxicity to estuarine crustaceans and fish. *Mar. Biol.* 27:75-88.
- Anonymous. 1979. Test 6: *Mysidopsis bahia* life cycle. Federal Register 44(53):16291.
- ASTM. 1990. Standard guide for conducting life cycle toxicity tests with salt water mysids. ASTM E1191-90. American Society for Testing and Materials, Philadelphia, PA.
- Battelle. 1988. A robust statistical method for estimating effects concentrations in short-term fathead minnow toxicity tests. Battelle Washington Environmental Program Office, Washington, DC.
- Bay, S.M., P.S. Oshida, and K.D. Jenkins. 1983. A simple new bioassay based on echinochrome synthesis by larval sea urchins. *Mar. Environ. Res.* 8:29-39.
- Beck, A.D., and D.A. Bengtson. 1982. International study on *Artemia* XXII: Nutrition in aquatic toxicology - Diet quality of geographical strains of the brine shrimp, *Artemia*. In: Pearson, J.G., R.B. Foster, and W.E. Bishop, eds., ASTM STP 766, American Society for Testing and Materials, Philadelphia, PA. pp. 161-169.
- Beck, A.D., D.A. Bengtson, and W.H. Howell. 1980. International study on *Artemia*. V. Nutritional value of five geographical strains of *Artemia*: Effects of survival and growth of larval Atlantic silversides, *Menidia menidia*. In: Persoone, G., P. Sorgeloos, D.A. Roels, and E. Jaspers. eds., The brine shrimp, *Artemia*. Vol. 3, Ecology, culturing, use in aquaculture. Universal Press, Wetteren, Belgium. pp. 249-259.
- Beckett, D.C., and P.A. Lewis. 1982. An efficient procedure for slide mounting of larval chironomids. *Trans. Amer. Fish. Soc.* 101(1):96-99.
- Bidwell, J.P., and S. Spotte. 1985. Artificial Seawaters: formulas and methods. Jones and Barlett, Publ., Boston, MA. 349 pp.
- Birge, W.J., J.A. Black, and A.G. Westerman. 1979. Evaluation of aquatic pollutants using fish and amphibian eggs as bioassay organisms. National Academy of Sciences, Washington, DC, p. 108-118.
- Birge, W.J., J.A., Black, A.G., Westerman, and B.A. Ramey. 1983. Fish and amphibian embryos - A model system for evaluating teratogenicity. *Fundam. Appl. Toxicol.* 3:237-242.
- Black, J.A., W.J. Birge, A.G. Westerman, and P.C. Francis. 1983. Comparative aquatic toxicology of aromatic hydrocarbons. *Fundam. Appl. Toxicol.* 3:353-358.

- Blaxter, J.H.S., F.S. Russell, and M. Yonge, eds. 1980. The biology of mysids and euphausiids. Part 1. The biology of the mysids. *Adv. Mar. Biol.* 18:1-319.
- Borthwick, P.W., J.M. Patrick, Jr., and D.P. Middaugh. 1985. Comparative acute sensitivities of early life stages of atherinid fishes to chloropyrifos and thiobencarb. *Arch. Environm. Contam. Toxicol.* 14:465-473.
- Breteler, R.J., J.W. Williams, and R.L. Buhl. 1982. Measurement of chronic toxicity using the opossum shrimp *Mysidopsis bahia*. *Hydrobiol.* 93:189-194.
- Buikema, A.L., Jr., B.R. Niederlehner, and J. Cairns, Jr. 1981. The effects of simulated refinery effluent and its components on the estuarine crustacean, *Mysidopsis bahia*. *Arch. Environm. Contam. Toxicol.* 10:231-240.
- Buikema, A.L., B.R. Niederlehner, and J. Cairns. 1982. Biological monitoring. Part IV. Toxicity Testing. *Water Res.* 16:239-262.
- Cripe, G.M., D.R. Nimmo, and T.L. Hamaker. 1981. Effects of two organophosphate pesticides on swimming stamina of the mysid *Mysidopsis bahia*. In: Vernberg, F.J., A. Calabrese, F.P. Thurberg, and W.B. Vernberg, eds., *Biological monitoring of marine pollutants*. Academic Press, NY, NY, pp 21-36.
- Davey, E.W., J.H. Gentile, S.J. Erickson, and P. Betzer. 1970. Removal of trace metals from marine culture media. *Limnol. Oceanogr.* 15:486-488.
- DeGraeve, G.M., J.D. Cooney, T.L. Pollock, N.G. Reichenbach, J.H. Dean, M.D. Marcus, and D.O. McIntyre. 1989. Fathead minnow 7-day test: round robin study. Intra- and interlaboratory study to determine the reproducibility of the seven-day fathead minnow larval survival and growth test. Battelle Columbus Division, Columbus, OH.
- DeGraeve, G.M., W.H. Clement, and M.F. Arthur. 1989. A method for conducting laboratory toxicity degradation evaluations of complex effluents. Battelle Columbus Division, Columbus, OH. 22 pp.
- Dinnel, P., Q. Stober, J. Link, M. Letourneau, W. Roberts, S. Felton, and R. Nakatani. 1983. Methodology and validation of a sperm cell toxicity test for testing toxic substances in marine waters. Final Report. Grant R/TOX. FRI-UW-83. University of Washington Sea Grant Program in cooperation with U. S. Environmental Protection Agency. 208 pp.
- Dorn, P.B., and J.H. Rogers. 1989. Variability associated with identification of toxics in National Pollutant Discharge Elimination System (NPDES) effluent toxicity tests. *Environ. Toxicol. Chem.* 8:893-902.

- Downs, T.R., and W.W. Wilfinger. 1983. Fluorometric quantification of DNA in cells and tissue. *Anal. Biochem.* 131: 538-547.
- Draper, N.R., and J.A. John. 1981. Influential observations and outliers in regression. *Technometrics* 23:21-26.
- Dye, J. E. 1980. The production and efficient use of freshly hatched brine shrimp nauplii (*Artemia*) in the larval rearing of marine fish at the hatcheries of the British White Fish Authority. In: Persoone, G., P. Sorgeloos, D.A. Roels, and E. Jaspers. eds., *The brine shrimp, Artemia*. Vol. 3, Ecology, culturing, use in aquaculture. Universal Press, Wetteren, Belgium. pp. 271-276.
- Farrell, D.H. 1979. Guide to the shallow-water mysids from Florida. Fla. Dept. Environ. Reg., Techn. Ser. 4(1):1-69.
- Finney, D.J. 1948. The Fisher-Yates test of significance in 2X2 contingency tables. *Biometrika* 35:145-156.
- Finney, D.J. 1985. The median lethal dose and its estimation. *Arch. Toxicol.* 56:215-218.
- Fotheringham, N., and S.L. Brunenmeister. 1975. Common marine invertebrates of the northwestern Gulf coast. Gulf Publ. Co., Houston, TX.
- Fujita, S., T. Watanabe, and C. Kitajima. 1980. Nutritional quality of *Artemia* from different localities as a living feed for marine fish from the viewpoint of essential fatty acids. In: Persoone, G., P. Sorgeloos, D.A. Roels, and E. Jaspers. eds., *The brine shrimp, Artemia*. Vol. 3, Ecology, culturing, use in aquaculture. Universal Press, Wetteren, Belgium. pp. 277-290.
- Gast, M.H., and W.A. Brungs. 1973. A procedure for separating eggs of the fathead minnow. *Prog. Fish. Cult.* 35:54.
- Gentile, J.H., S.M. Gentile, N.G. Hairston, Jr., and B.K. Sullivan. 1982. The use of life-tables for evaluating the chronic toxicity of pollutants to *Mysidopsis bahia*. *Hydrobiol.* 93:179-187.
- Gentile, S.M., J.H. Gentile, J. Walker, and J.F. Heltshe. 1982. Chronic effects of cadmium on two species of mysid shrimp: *Mysidopsis bahia* and *M. bigelowi*. *Hydrobiol.* 93:195-204.
- Hall, W.S., J.B. Patoczka, R.J. Mirenda, B.A. Porter, and E. Miller. 1989. Acute toxicity of industrial surfactants to *Mysidopsis bahia*. *Arch. Environ. Contam. Toxicol.* 18:765-772.
- Hutton, C.H., P.F. DeLisle, M.H. Roberts, and D.A. Hepworth. 1986. *Chrysaora quinquecirrha*: a predator on mysids (*Mysidopsis bahia*) in culture. *Progr. Fish-Cult.* 48:154-155.

- Jackim, E., and D. Nacci. 1986. Improved sea urchin DNA-based embryo growth toxicity test. *Environ. Toxicol. Chem.* 5:561-565.
- Jensen, J. P. 1958. The relation between body size and number of eggs in marine malacostrakes. *Meddr. Danm. Fisk.-og Havunders* 2:1-25.
- Jensen, A. 1984a. Marine ecotoxicological tests with seaweeds. *In*: Personne, G., E. Jaspers, and C. Claus, eds., *Ecotoxicological testing for the marine environment*. Vol. 1. State University of Ghent and Institute for Marine Scientific Research, Bredene, Belgium. pp. 181-193.
- Jensen, A. 1984b. Marine ecotoxicological tests with phytoplankton. *In*: Personne, G., E. Jaspers, and C. Claus, eds., *Ecotoxicological testing for the marine environment*. Vol. 1. State University of Ghent and Institute for Marine Scientific Research, Bredene, Belgium. pp. 195-213.
- Johns, D.M., W.J. Berry, and W. Walton. 1981. International study on *Artemia*. XVI. Survival, growth and reproductive potential of the mysid *Mysidopsis bahia* Molenock fed various geographical strains of the brine shrimp *Artemia*. *J. Exp. Mar. Biol. Ecol.* 53:209-219.
- Johns, D.M., M.E. Peters, and A.D. Beck. 1980. International study on *Artemia*. VI. Nutritional value of geographical and temporal strains of *Artemia*: effects on survival and growth of two species of Brachyuran larvae. *In*: Persoone, G., P. Sorgeloos, D.A. Roels, and E. Jaspers, eds., *The brine shrimp, Artemia*. Vol. 3, Ecology, culturing, use in aquaculture. Universal Press, Wetteren, Belgium. pp. 291-304.
- Jop, K.M., J.H. Rogers, Jr., P.B. Dorn, and K.L. Dickson. 1986. Use of hexavalent chromium as a reference toxicant in aquatic toxicity tests. *In*: T.M. Poston, and R. Purdy, eds., *Aquatic Toxicology and Environmental Fate*, ASTM STP 921, American Society for Testing and Materials, Philadelphia, PA. pp. 390-403.
- Kenaga, E.E. 1982. The use of environmental toxicology and chemistry data in hazard assessment: Progress, needs, challenges. *Environ. Toxicol. Chem.* 1:69-79.
- Kenaga, E.E., and R.J. Moolenaar. 1976. Fish and *Daphnia* toxicity as surrogates for aquatic vascular plants and algae. *Environ. Sci. Technol.* 13:1479-1480.
- Kester, D.R., I.W. Dredall, D.N. Connors, and R.M. Pytokowicz. 1967. Preparation of artificial seawater. *Limnol. Oceanogr.* 12:176-179.

- Klein-MacPhee, G., W.H. Howell, and A.D. Beck. 1980. International study on *Artemia*. VII. Nutritional value of five geographical strains of *Artemia* to winter flounder *Pseudopleuronectes americanus* larvae. In: Persoone, G., P. Sorgeloos, D.A. Roels, and E. Jaspers. eds., The brine shrimp, *Artemia*. Vol. 3, Ecology, culturing, use in aquaculture. Universal Press, Wetteren, Belgium. pp. 305-312.
- Klein-MacPhee, G., W.H. Howell, and A.D. Beck. 1982. International study on *Artemia*. XX. Comparison of a reference and four geographical strains of *Artemia* as food for winter flounder (*Pseudopleuronectes americanus*) larvae. *Aquacult.* 29:279-288.
- Lawler, A.R., and S.L. Shepard. 1978. Procedures for eradication of hydrozoan pests in closed-system mysid culture. *Gulf Res. Rept.* 6:177-178.
- Leger, P., and P. Sorgeloos. 1982. Automation in stock-culture maintenance and juvenile separation of the mysid *Mysidopsis bahia* (Molenock). *Aquacult. Eng.* 1:45-53.
- Mauchline, J., and M. Murano. 1977. World list of the Mysidacea, Crustacea. *J. Tokyo Univ. Fish.* 64:39-88.
- Molenock, J. 1969. *Mysidopsis bahia*, a new species of mysid (Crustacea: Mysidacea) from Galveston Bay, Texas. *Tulane Stud. Zool. Bot.* 15(3):113-116.
- Morgan, M.D. 1982. The ecology of Mysidacea. *Developments in hydrobiology* 10. W. Junk, Publ., The Hague, Netherlands. 232 pp.
- Nacci, D., E. Jackim, and R. Walsh. 1986. Comparative evaluation of three rapid marine toxicity tests: Sea urchin early embryo growth test, sea urchin sperm cell toxicity test and Microtox. *Environ. Toxicol. Chem.* 5:521-525.
- Nimmo, D.R., L.H. Bahner, R.A. Rigby, J.M. Sheppard, and A.J. Wilson, Jr. 1977. *Mysidopsis bahia*: an estuarine species suitable for life-cycle toxicity tests to determine the effects of a pollutant. In: Mayer, F.L., and J.L. Hamelin, eds., *Aquatic Toxicology and Hazard Evaluation*. ASTM STP 634, American Society for Testing and Materials, Philadelphia, PA. pp. 109-116.
- Nimmo, D.R., and T.L. Hamaker. 1982. Mysids in toxicity testing - a review. *Hydrobiol.* 93:171-178.
- Nimmo, D.R., T.L. Hamaker, J.C. Moore, and C.A. Sommers. 1979. Effect of diflubenzuron on an estuarine crustacean. *Bull. Environm. Contam. Toxicol.* 22:767-770.

- Nimmo, D.R., T.L. Hamaker, E. Matthews, and J.C. Moore. 1981. An overview of the acute and chronic effects of first and second generation pesticides on an estuarine mysid. *In*: Vernberg, F.J., A. Calabrese, F.P. Thurberg, and W.B. Vernberg, eds., *Biological Monitoring of Marine Pollutants*. Academic Press, NY. pp. 3-19.
- Nimmo, D.R., T.L. Hamaker, E. Matthews, and W.T. Young. 1982. The long-term effects of suspended particulates on survival and reproduction of the mysid shrimp, *Mysidopsis bahia*, in the laboratory. *In*: Mayer, G.F., ed., *Ecological Stress and the New York Bight: Science and Management*. Estuarine Res. Found., Columbia, SC. pp. 41-50.
- Nimmo, D.R., T.L. Hamaker, J.C. Moore, and R.A. Wood. 1980. Acute and chronic effects of Dimilin on survival and reproduction of *Mysidopsis bahia*. *In*: Eaton, J.G., P.R. Parrish, and A.C. Hendricks, eds., ASTM STP 707, American Society for Testing and Materials, Philadelphia, PA. pp. 366-376.
- Nimmo, D.R., T.L. Hamaker, and C.A. Sommers. 1978a. Culturing the mysid (*Mysidopsis bahia*) in flowing seawater or a static system. *In*: Bioassay Procedures for the Ocean Disposal Permit Program, U. S. Environmental Protection Agency, Environmental Research Laboratory, Gulf Breeze, FL 332561. EPA/600/9-78/010. pp. 59-60.
- Nimmo, D.R., T.L. Hamaker, and C.A. Sommers. 1978b. Entire life cycle toxicity test using mysids (*Mysidopsis bahia*) in flowing water. *In*: Bioassay Procedures for the Ocean Disposal Permit Program, U. S. Environmental Protection Agency, Environmental Research Laboratory, Gulf Breeze, FL 32561. EPA/600/9-78/010. pp. 64-68.
- Nimmo, D.R., and E.S. Iley, Jr. 1982. Culturing and chronic toxicity of *Mysidopsis bahia* using artificial seawater. Office of Toxic Substances, U.S. Environmental Protection Agency, Washington, DC 20460. Publ. PA 902.
- Nimmo, D.R., R.A. Rigby, L.H. Bahner, and J.M. Sheppard. 1978. The acute and chronic effects of cadmium on the estuarine mysid, *Mysidopsis bahia*. *Bull. Environm. Contam. Toxicol.* 19(1):80-85.
- Pearson, E.S., and T.O. Hartley. 1962. *Biometrika tables for statisticians*. Vol. 1. Cambridge Univ. Press, England. pp. 65-70.
- Persoone, G., E. Jaspers, and C. Claus, eds. 1980. *Ecotoxicological testing for the marine environment*. Vol. 1. State University of Ghent and Institute for Marine Scientific Research, Bredene, Belgium.
- Persoone, G., P. Sorgeloos, O. Roels, and E. Jaspers. eds. 1980a. The brine shrimp *Artemia*. Vol. 1. Morphology, genetics, radiobiology, toxicology. Proceedings of the International Symposium on the brine shrimp *Artemia salina*, Corpus Christi, Texas, 1979. Universal Press, Wetteren, Belgium. 318 pp.

- Persoone, G., P. Sorgeloos, O. Roels, and E. Jaspers. eds. 1980b. The brine shrimp *Artemia*. Vol. 2. Physiology, biochemistry, molecular biology. Proceedings of the International Symposium on the brine shrimp *Artemia salina*, Corpus Christi, Texas, 1979. Universal Press, Wetteren, Belgium. 636 pp.
- Persoone, G., P. Sorgeloos, O. Roels, and E. Jaspers. eds. 1980c. The brine shrimp *Artemia*. Vol. 3. Ecology, culturing, use in aquaculture. Proceedings of the International Symposium on the brine shrimp *Artemia salina*, Corpus Christi, Texas, 1979. Universal Press, Wetteren, Belgium. 428 pp.
- Rand, G.M., and S.R. Petrocelli. 1985. Fundamentals of aquatic toxicology. Hemisphere Publ. Corp., New York. 66 pp.
- Reitsema, L.A. 1981. The growth, respiration, and energetics of *Mysidopsis almyra* (Crustacea; Mysidacea) in relation to temperature, salinity, and hydrocarbon exposure. Ph.D. thesis, Texas A & M University, College Station, TX.
- Reitsema, L.A., and J.M. Neff. 1980. A recirculating artificial seawater system for the laboratory culture of *Mysidopsis almyra* (Crustacea; Pericaridea). *Estuaries* 3:321-323.
- Sorgeloos, P. 1980. Life history of the brine shrimp *Artemia*. In: Persoone, G., P. Sorgeloos, D.A. Roels, and E. Jaspers. eds., The brine shrimp, *Artemia*. Vol. 1. Morphology, genetics, radiobiology, toxicology. Proceedings of the International Symposium on the brine shrimp *Artemia salina*, Corpus Christi, Texas, 1979. Universal Press, Wetteren, Belgium. pp. ix-xxii.
- Spehar, R.L., D.K. Tanner, and B.R. Nordling. 1983. Toxicity of the synthetic pyrethroids, permethrin, AC-222, 705, and their accumulation in early life stages of fathead minnows and snails. *Aquat. Toxicol.* 3:171-182.
- Sprague, J.B. 1969. Measurement of pollutant toxicity to fish. I. Bioassay methods for acute toxicity. *Water Res.* 3:793-821.
- Steel, R.G., and J.H. Torrie. 1960. Principles and procedures of statistics with special reference to biological sciences. McGraw-Hill Publ., NY, NY.
- Steele, R.L., and M.D. Hanisak. 1978. Sensitivity of some brown algal reproductive stages to oil pollution. In: Jensen, A. and J. R. Stein, eds., Proceedings of the Ninth International Seaweed Symposium, Vol. 9, Science Press, Princeton, NJ. pp. 181-190.

- Steele, R.L., and G.B. Thursby. 1983. A toxicity test using life stages of *Champia parvula* (Rhodophyta). In: Bishop, W.E., R.D. Cardwell, and B.B. Heidolph, eds., Aquatic Toxicology and Hazard Assessment: Sixth Symposium. STP 802, American Society for Testing and Materials, Philadelphia, PA. pp. 73-89.
- Stuck, K.C., H.M. Perry, and R.W. Heard. 1979. An annotated key to the Mysidacea of the North Central Gulf of Mexico. Gulf Res. Rept. 6(3):225-238.
- Tarzwel, C.M. 1971. Bioassays to determine allowable waste concentrations in the aquatic environment. In: Cole, H.A. (Organizer), A discussion on biological effects of pollution in the sea. Proc. Roy. Soc. Lond. B 177(1048):279-285.
- Tattersall, W.M., and O.S. Tattersall. 1951. The British Mysidacea. Royal Soc., London, England. 460 pp.
- Theilacker, G.H., and M.F. McMaster. 1971. Mass culture of the rotifer *Brachionus plicatilis* and its evaluation as a food for larval anchovies. Mar. Biol. 10:183-188.
- Thompson, R.S., and E.M. Burrows. 1984. The toxicity of copper, zinc, and mercury to the brown macroalga *Laminaria saccharina*. In: Persoone, G., E. Jaspers, and C. Claus, eds., Ecotoxicological testing for the marine environment, Vol. 2, State University of Ghent and Institute for Marine Scientific Research, Bredene, Belgium. pp. 259-269.
- Thursby, G.B., and R.L. Steele. 1984. Toxicity of arsenite and arsenate to the marine macroalga *Champia parvula*. Environ. Toxicol. Chem. 3:391-397.
- Thursby, G.B., and R.L. Steele. 1986. Comparison of short- and long-term sexual reproduction tests with the marine red alga *Champia parvula*. Environ. Toxicol. Chem. 5:1013-1018.
- Thursby, G.B., R.L. Steele, and M.E. Kane. 1985. Effect of organic chemicals on growth and reproduction in the marine red alga *Champia parvula*. Environ. Toxicol. Chem. 4:797-805.
- USEPA. 1977. Occupational health and safety manual. Office of Planning and Management, U. S. Environmental Protection Agency, Washington, DC 20460.
- USEPA. 1978. Methods for measuring the acute toxicity of effluents to aquatic organisms. Second edition. Peltier, W., Environmental Monitoring and Support Laboratory - Cincinnati, U. S. Environmental Protection Agency, Cincinnati, OH 45268. EPA/600/4-78/012.
- USEPA. 1981a. Acute toxicity test standard using mysid shrimp in static and flow-through systems. Toxic Substances Control Act, Section 4. U. S. Environmental Protection Agency, Office of Toxic Substances, Health and Environmental Review Division, Washington, DC 20460.

- USEPA. 1981b. Chronic toxicity test standard using mysid shrimp in a flow-through system. Toxic Substances Control Act, Section 4. U. S. Environmental Protection Agency, Office of Toxic Substances, Health and Environmental Review Division, Washington, DC 20460.
- USEPA. 1981c. Technical support document for using mysid shrimp in acute and chronic toxicity tests. Toxic Substances Control Act, Section 4. U. S. Environmental Protection Agency, Office of Toxic Substances, Health and Environmental Review Division, Washington, DC 20460.
- USEPA. 1981d. Effluent toxicity screening test using *Daphnia* and mysid shrimp. Weber, C.I., and W.H. Peltier. Environmental Monitoring and Support Laboratory, U. S. Environmental Protection Agency, Cincinnati, OH 45268.
- USEPA. 1984. Development of water quality-based permit limitations for toxic pollutants: National Policy. Fed. Reg. 49:9016-9019.
- USEPA. 1985a. Technical support document for water quality-based control. Office of Water, U. S. Environmental Protection Agency, Washington, DC 20460.
- USEPA. 1985b. Ambient water quality criteria for ammonia - 1984. Office of Water Regulations and Standards, Office of Water, U. S. Environmental Protection Agency, Washington, DC 20460. EPA/440/5-85/001.
- USEPA. 1985c. Ambient water quality criteria for ammonia - 1984. Office of Water Regulations and Standards, Office of Water, U. S. Environmental Protection Agency, Washington, DC 20460. EPA/440/5-85/001.
- USEPA. 1985d. Hazard evaluation division: Standard evaluation procedure: Acute toxicity test for estuarine and marine organisms (shrimp 96-hour acute toxicity test). Rieder, D., Office of Pesticides Programs, U. S. Environmental Protection Agency, Washington, DC 20460. EPA/540/9-85/010.
- Usher, R.R., and D.A. Bengtson. 1981. Survival and growth of sheepshead minnow larvae and juveniles on diet of *Artemia* nauplii. Prog. Fish-Cult. 43(2):102-105.
- Vanhaecke, P., and P. Sorgeloos. 1983. International study on *Artemia*. XIX. Hatching data for ten commercial sources of brine shrimp cysts and re-evaluation of the "hatching efficiency" concept. Aquacult. 30:43-52.
- Walsh, G.E., L.H. Bahner, and W.B. Horning. 1980. Toxicity of textile mill effluents to freshwater and estuarine algae, crustaceans, and fishes. Environ. Pollut. (Ser. A.) 21:169-179.
- Ward, S.H. 1984. A system for laboratory rearing of the mysid, *Mysidopsis bahia* Molenock. Progr. Fish-Cult. 46(3):170-175.

- Ward, S.H. 1987. Feeding response of the mysid *Mysidopsis bahia* reared on *Artemia*. Prog. Fish-Cult. 49:29-33.
- Ward, S.H. 1990. Procedures for toxicant testing and culture of the marine macroalga, *Champia parvula*. Technical Report, U. S. Environmental Protection Agency, Region 2, New York, NY 20278.
- Welch, P.S. 1948. Limnological methods. McGraw-Hill Book Company, New York, NY.
- Zarogian, G.E., G. Pesch, and G. Morrison. 1969. Formulation of an artificial seawater media suitable for oyster larvae development. Amer. Zool. 9:1141.
- Zillioux, E.J., H.R. Foulk, J.C. Prager, and J.A. Cardin. 1973. Using *Artemia* to assay oil dispersant toxicities. JWPCF 45:2389-2396.

APPENDICES

	Page
A. Independence, Randomization, and Outliers	403
1. Statistical Independence	403
2. Randomization	403
3. Outliers	408
B. Validating Normality and Homogeneity of Variance Assumptions	409
1. Introduction	409
2. Tests for Normal Distribution of Data	409
3. Test for Homogeneity of Variance	417
4. Transformations of the Data	417
C. Dunnett's Procedure	419
1. Manual Calculations	419
2. Computer Calculations	426
D. T test with the Bonferroni Adjustment	432
E. Steel's Many-one Rank Test	438
F. Wilcoxon Rank Sum Test with the Bonferroni Adjustment	443
G. Single Concentration Toxicity Test - Comparison of Control with 100% Effluent or Receiving Water	450
H. Probit Analysis	454
I. Spearman-Karber Method	457
J. Trimmed Spearman-Karber Method	462
K. Graphical Method	467
L. Linear Interpolation Method	471
1. General Procedure	471

APPENDICES (CONTINUED)

	Page
2. Data Summary and Plots	471
3. Monotonicity	471
4. Linear Interpolation Method	472
5. Confidence Intervals	473
6. Manual Calculations	473
7. Computer Calculations	477
Cited References	482

APPENDIX A

INDEPENDENCE, RANDOMIZATION, AND OUTLIERS

1. STATISTICAL INDEPENDENCE

1.1 Dunnett's Procedure and the t test with Bonferroni's adjustment are parametric procedures based on the assumptions that (1) the observations within treatments are independent and normally distributed, and (2) that the variance of the observations is homogeneous across all toxicant concentrations and the control. Of the three possible departures from the assumptions, non-normality, heterogeneity of variance, and lack of independence, those caused by lack of independence are the most difficult to resolve (see Scheffe, 1959). For toxicity data, statistical independence means that given knowledge of the true mean for a given concentration or control, knowledge of the error in any one actual observation would provide no information about the error in any other observation. Lack of independence is difficult to assess and difficult to test for statistically. It may also have serious effects on the true alpha or beta level. Therefore, it is of utmost importance to be aware of the need for statistical independence between observations and to be constantly vigilant in avoiding any patterned experimental procedure that might compromise independence. One of the best ways to help insure independence is to follow proper randomization procedures throughout the test.

2. RANDOMIZATION

2.1 Randomization of the distribution of test organisms among test chambers, and the arrangement of treatments and replicate chambers is an important part of conducting a valid test. The purpose of randomization is to avoid situations where test organisms are placed serially into test chambers, or where all replicates for a test concentration are located adjacent to one another, which could introduce bias into the test results.

2.2 An example of randomization of the distribution of test organisms among test chambers, and an example of randomization of arrangement of treatments and replicate chambers are described using the Sheepshead Minnow Larval Survival and Growth test. For the purpose of the example, the test design is as follows: Five effluent concentrations are tested in addition to the control. The effluent concentrations are as follows: 6.25%, 12.5%, 25.0%, 50.0%, and 100.0%. There are four replicate chambers per treatment. Each replicate chamber contains ten fish.

2.3 RANDOMIZATION OF FISH TO REPLICATE CHAMBERS EXAMPLE

2.3.1 Consider first the random assignment of the fish to the replicate chambers. The first step is to label each of the replicate chambers with the control or effluent concentration and the replicate number. The next step is to assign each replicate chamber four double-digit numbers. An example of this assignment is provided in Table A.1. Note that the double digits 00 and 97 through 99 were not used.

TABLE A.1. RANDOM ASSIGNMENT OF FISH TO REPLICATE CHAMBERS EXAMPLE
ASSIGNED NUMBERS FOR EACH REPLICATE CHAMBER

Assigned Numbers	Replicate Chamber
01, 25, 49, 73	Control, replicate chamber 1
02, 26, 50, 74	Control, replicate chamber 2
03, 27, 51, 75	Control, replicate chamber 3
04, 28, 52, 76	Control, replicate chamber 4
05, 29, 53, 77	6.25% effluent, replicate chamber 1
06, 30, 54, 78	6.25% effluent, replicate chamber 2
07, 31, 55, 79	6.25% effluent, replicate chamber 3
08, 32, 56, 80	6.25% effluent, replicate chamber 4
09, 33, 57, 81	12.5% effluent, replicate chamber 1
10, 34, 58, 82	12.5% effluent, replicate chamber 2
11, 35, 59, 83	12.5% effluent, replicate chamber 3
12, 36, 60, 84	12.5% effluent, replicate chamber 4
13, 37, 61, 85	25.0% effluent, replicate chamber 1
14, 38, 62, 86	25.0% effluent, replicate chamber 2
15, 39, 63, 87	25.0% effluent, replicate chamber 3
16, 40, 64, 88	25.0% effluent, replicate chamber 4
17, 41, 65, 89	50.0% effluent, replicate chamber 1
18, 42, 66, 90	50.0% effluent, replicate chamber 2
19, 43, 67, 91	50.0% effluent, replicate chamber 3
20, 44, 68, 92	50.0% effluent, replicate chamber 4
21, 45, 69, 93	100.0% effluent, replicate chamber 1
22, 46, 70, 94	100.0% effluent, replicate chamber 2
23, 47, 71, 95	100.0% effluent, replicate chamber 3
24, 48, 72, 96	100.0% effluent, replicate chamber 4

2.3.2 The random numbers used to carry out the random assignment of fish to replicate chambers are provided in Table A.2. The third step is to choose a starting position in Table A.2, and read the first double digit number. The first number read identifies the replicate chamber for the first fish taken from the tank. For the example, the first entry in row 2 was chosen as the starting position. The first number in this row is 37. According to Table A.1, this number corresponds to replicate chamber 1 of the 25.0% effluent concentration. Thus, the first fish taken from the tank is to be placed in replicate chamber 1 of the 25.0% effluent concentration.

2.3.3 The next step is to read the double digit number to the right of the first one. The second number identifies the replicate chamber for the second fish taken from the tank. Continuing the example, the second number read in row 2 of Table A.2 is 54. According to Table A.1, this number corresponds to replicate chamber 2 of the 6.25% effluent concentration. Thus, the second fish taken from the tank is to be placed in replicate chamber 2 of the 6.25% effluent concentration.

TABLE A.2. TABLE OF RANDOM NUMBERS (Dixon and Massey, 1983)

10 09 73 25 33	76 52 01 35 86	34 67 35 43 76	80 95 90 91 17	39 29 27 49 45
37 54 20 48 05	64 89 47 42 96	24 80 52 40 37	20 63 61 04 02	00 82 29 16 65
08 42 26 89 53	19 64 50 93 03	23 20 90 25 60	15 95 33 47 64	35 08 03 36 06
99 01 90 25 29	09 37 67 07 15	38 31 13 11 65	88 67 67 43 97	04 43 62 76 59
12 80 79 99 70	80 15 73 61 47	64 03 23 66 53	98 95 11 68 77	12 27 17 68 33
66 06 57 47 17	34 07 27 68 50	36 69 73 61 70	65 81 33 98 85	11 19 92 91 70
31 06 01 08 05	45 57 18 24 06	35 30 34 26 14	86 79 90 74 39	23 40 30 97 32
85 26 97 76 02	02 05 16 56 92	68 66 57 48 18	73 05 38 52 47	18 62 38 85 79
63 57 33 21 35	05 32 54 70 48	90 55 35 75 48	28 46 82 87 09	83 49 12 56 24
73 79 64 57 53	03 52 96 47 78	35 80 83 42 82	60 93 52 03 44	35 27 38 84 35
98 52 01 77 67	14 90 56 86 07	22 10 94 05 58	60 97 09 34 33	50 50 07 39 98
11 80 50 54 31	39 80 82 77 32	50 72 56 82 48	29 40 52 42 01	52 77 56 78 51
83 45 29 96 34	06 28 89 80 83	13 74 67 00 78	18 47 54 06 10	68 71 17 78 17
88 68 54 02 00	86 50 75 84 01	36 76 66 79 51	90 36 47 64 93	29 60 91 10 62
99 59 46 73 48	87 51 76 49 69	91 82 60 89 28	93 78 56 13 68	23 47 83 41 13
65 48 11 76 74	17 46 85 09 50	58 04 77 69 74	73 03 95 71 86	40 21 81 65 44
80 12 43 56 35	17 72 70 80 15	45 31 82 23 74	21 11 57 82 53	14 38 55 37 63
74 35 09 98 17	77 40 27 72 14	43 23 60 02 10	45 52 16 42 37	96 28 60 26 55
69 91 62 68 03	66 25 22 91 48	36 93 68 72 03	76 62 11 39 90	94 40 05 64 18
09 89 32 05 05	14 22 56 85 14	46 42 75 67 88	96 29 77 88 22	54 38 21 45 98
91 49 91 45 23	68 47 92 76 86	46 16 28 35 54	94 75 08 99 23	37 08 92 00 48
80 33 69 45 98	26 94 03 68 58	70 29 73 41 35	53 14 03 33 40	42 05 08 23 41
44 10 48 19 49	85 15 74 79 54	32 97 92 65 75	57 60 04 08 81	22 22 20 64 13
12 55 07 37 42	11 10 00 20 40	12 86 07 46 97	96 64 48 94 39	28 70 72 58 15
63 60 64 93 29	16 50 53 44 84	40 21 95 25 63	43 65 17 70 82	07 20 73 17 90
61 19 69 04 46	26 45 74 77 74	51 92 43 37 29	65 39 45 95 93	42 58 26 05 27
15 47 44 52 66	95 27 07 99 53	59 36 78 38 48	82 39 61 01 18	33 21 15 94 66
94 55 72 85 73	67 89 75 43 87	54 62 24 44 31	91 19 04 25 92	92 92 74 59 73
42 48 11 62 13	97 34 40 87 21	16 86 84 87 67	03 07 11 20 59	25 70 14 66 70
23 52 37 83 17	73 20 88 98 37	68 93 59 14 16	26 25 22 96 63	05 52 28 25 62
04 49 35 24 94	75 24 63 38 24	45 86 25 10 25	61 96 27 93 35	65 33 71 24 72
00 54 99 76 54	64 05 18 81 59	96 11 96 38 96	54 69 28 23 91	23 28 72 95 29
35 96 31 53 07	26 89 80 93 45	33 35 13 54 62	77 97 45 00 24	90 10 33 93 33
59 80 80 83 91	45 42 72 68 42	83 60 94 97 00	13 02 12 48 92	78 56 52 01 06
46 05 88 52 36	01 39 09 22 86	77 28 14 40 77	93 91 08 36 47	70 61 74 29 41
32 17 90 05 97	87 37 92 52 41	05 56 70 70 07	86 74 31 71 57	85 39 41 18 38
69 23 46 14 06	20 11 74 52 04	15 95 66 00 00	18 74 39 24 23	97 11 89 63 38
19 56 54 14 30	01 75 87 53 79	40 41 92 15 85	66 67 43 68 06	84 96 28 52 07
45 15 51 49 38	19 47 60 72 46	43 66 79 45 43	59 04 79 00 33	20 82 66 95 41
94 86 43 19 94	36 16 81 08 51	34 88 88 15 53	01 54 03 54 56	05 01 45 11 76
98 08 62 48 26	45 24 02 84 04	44 99 90 88 96	39 09 47 34 07	35 44 13 18 80
33 18 51 62 32	41 94 15 09 49	89 43 54 85 81	88 69 54 19 94	37 54 87 30 43
80 95 10 04 06	96 38 27 07 74	20 15 12 33 87	25 01 62 52 98	94 62 46 11 71
79 75 24 91 40	71 96 12 82 96	69 86 10 25 91	74 85 22 05 39	00 38 75 95 79
18 63 33 25 37	98 14 50 65 71	31 01 02 46 74	05 45 56 14 27	77 93 89 19 36
74 02 94 39 02	77 55 73 22 70	97 79 01 71 19	52 52 75 80 21	80 81 45 17 48
54 17 84 56 11	80 99 33 71 43	05 33 51 29 69	56 12 71 92 55	36 04 09 03 24
11 66 44 98 83	52 07 98 48 27	59 38 17 15 39	09 97 33 34 40	88 46 12 33 56
48 32 47 79 28	31 24 96 47 10	02 29 53 68 70	32 30 75 75 46	15 02 00 99 94
69 07 49 41 38	87 63 79 19 76	35 58 40 44 01	10 51 82 16 15	01 84 87 69 38

2.3.4 Continue in this fashion until all the fish have been randomly assigned to a replicate chamber. In order to fill each replicate chamber with ten fish, the assigned numbers will be used more than once. If a number is read from the table that was not assigned to a replicate chamber, then ignore it and continue to the next number. If a replicate chamber becomes filled and a number is read from the table that corresponds to it, then ignore that value and continue to the next number. The first ten random assignments of fish to replicate chambers for the example are summarized in Table A.3.

TABLE A.3. EXAMPLE OF RANDOM ASSIGNMENT OF FIRST TEN FISH TO REPLICATE CHAMBERS

Fish	Assignment
First fish taken from tank	25.0% effluent, replicate chamber 1
Second fish taken from tank	6.25% effluent, replicate chamber 2
Third fish taken from tank	50.0% effluent, replicate chamber 4
Fourth fish taken from tank	100.0% effluent, replicate chamber 4
Fifth fish taken from tank	6.25% effluent, replicate chamber 1
Sixth fish taken from tank	25.0% effluent, replicate chamber 4
Seventh fish taken from tank	50.0% effluent, replicate chamber 1
Eighth fish taken from tank	100.0% effluent, replicate chamber 3
Ninth fish taken from tank	50.0% effluent, replicate chamber 2
Tenth fish taken from tank	100.0% effluent, replicate chamber 4

2.3.5 Four double-digit numbers were assigned to each replicate chamber (instead of one, two, or three double-digit numbers) in order to make efficient use of the random number table (Table A.2). To illustrate, consider the assignment of only one double-digit number to each replicate chamber: the first column of assigned numbers in Table A.1. Whenever the numbers 00 and 25 through 99 are read from Table A.2, they will be disregarded and the next number will be read.

2.4 RANDOMIZATION OF REPLICATE CHAMBERS TO POSITIONS EXAMPLE

2.4.1 Next consider the random assignment of the 24 replicate chambers to positions within the water bath (or equivalent). Assume that the replicate chambers are to be positioned in a four row by six column rectangular array. The first step is to label the positions in the water bath. Table A.4 provides an example layout.

2.4.2 The second step is to assign each of the 24 positions four double-digit numbers. An example of this assignment is provided in Table A.5. Note that the double digits 00 and 97 through 99 were not used.

2.4.3 The random numbers used to carry out the random assignment of replicate chambers to positions are provided in Table A.2. The third step is to choose a starting position in Table A.2, and read the first double-digit number. The first number read identifies the position for the first replicate chamber of the control. For the example, the first entry in row 10 of Table A.2 was

TABLE A.4. RANDOM ASSIGNMENT OF REPLICATE CHAMBERS TO POSITIONS: EXAMPLE LABELLING THE POSITIONS WITHIN THE WATER BATH

1	2	3	4	5	6
7	8	9	10	11	12
13	14	15	16	17	18
19	20	21	22	23	24

TABLE A.5. RANDOM ASSIGNMENT OF REPLICATE CHAMBERS TO POSITIONS: EXAMPLE ASSIGNED NUMBERS FOR EACH POSITION

Assigned Numbers	Position
01, 25, 49, 73	1
02, 26, 50, 74	2
03, 27, 51, 75	3
04, 28, 52, 76	4
05, 29, 53, 77	5
06, 30, 54, 78	6
07, 31, 55, 79	7
08, 32, 56, 80	8
09, 33, 57, 81	9
10, 34, 58, 82	10
11, 35, 59, 83	11
12, 36, 60, 84	12
13, 37, 61, 85	13
14, 38, 62, 86	14
15, 39, 63, 87	15
16, 40, 64, 88	16
17, 41, 65, 89	17
18, 42, 66, 90	18
19, 43, 67, 91	19
20, 44, 68, 92	20
21, 45, 69, 93	21
22, 46, 70, 94	22
23, 47, 71, 95	23
24, 48, 72, 96	24

chosen as the starting position. The first number in this row was 73. According to Table A.5, this number corresponds to position 1. Thus, the first replicate chamber for the control will be placed in position 1.

2.4.4 The next step is to read the double-digit number to the right of the first one. The second number identifies the position for the second replicate chamber of the control. Continuing the example, the second number read in row 10 of Table A.2 is 79. According to Table A.5, this number corresponds to position 7. Thus, the second replicate chamber for the control will be placed in position 7.

2.4.5 Continue in this fashion until all the replicate chambers have been assigned to a position. The first four numbers read will identify the positions for the control replicate chambers, the second four numbers read will identify the positions for the lowest effluent concentration replicate chambers, and so on. If a number is read from the table that was not assigned to a position, then ignore that value and continue to the next number. If a number is repeated in Table A.2, then ignore the repeats and continue to the next number. The complete randomization of replicate chambers to positions for the example is displayed in Table A.6.

TABLE A.6. EXAMPLE OF RANDOM ASSIGNMENT OF REPLICATE CHAMBERS TO POSITIONS: ASSIGNMENT OF ALL 24 POSITIONS

Control	100.0%	6.25%	6.25%	6.25%	12.5%
Control	12.5%	Control	25.0%	12.5%	25.0%
100.0%	50.0%	100.0%	Control	100.0%	25.0%
50.0%	50.0%	25.0%	50.0%	12.5%	6.25%

2.4.6 Four double-digit numbers were assigned to each position (instead of one, two, or three) in order to make efficient use of the random number table (Table A.2). To illustrate, consider the assignment of only one double-digit number to each position: the first column of assigned numbers in Table A.5. Whenever the numbers 00 and 25 through 99 are read from Table A.2, they will be disregarded and the next number will be read.

3. OUTLIERS

3.1 An outlier is an inconsistent or questionable data point that appears unrepresentative of the general trend exhibited by the majority of the data. Outliers may be detected by tabulation of the data, plotting, and by an analysis of the residuals. An explanation should be sought for any questionable data points. Without an explanation, data points should be discarded only with extreme caution. If there is no explanation, the analysis should be performed both with and without the outlier, and the results of both analyses should be reported.

3.2 Gentleman-Wilk's A statistic gives a test for the condition that the extreme observation may be considered an outlier. For a discussion of this, and other techniques for evaluating outliers, see Draper and John (1981).

APPENDIX B

VALIDATING NORMALITY AND HOMOGENEITY OF VARIANCE ASSUMPTIONS

1. INTRODUCTION

1.1 Dunnett's Procedure and the t test with Bonferroni's adjustment are parametric procedures based on the assumptions that the observations within treatments are independent and normally distributed, and that the variance of the observations is homogeneous across all toxicant concentrations and the control. These assumptions should be checked prior to using these tests, to determine if they have been met. Tests for validating the assumptions are provided in the following discussion. If the tests fail (if the data do not meet the assumptions), a nonparametric procedure such as Steel's Many-one Rank Test may be more appropriate. However, the decision on whether to use parametric or nonparametric tests may be a judgement call, and a statistician should be consulted in selecting the analysis.

2. TEST FOR NORMAL DISTRIBUTION OF DATA

2.1 SHAPIRO-WILK'S TEST

2.1.1 One formal test for normality is the Shapiro-Wilk's Test (Conover, 1980). The test statistic is obtained by dividing the square of an appropriate linear combination of the sample order statistics by the usual symmetric estimate of variance. The calculated W must be greater than zero and less than or equal to one. This test is recommended for a sample size of 50 or less. If the sample size is greater than 50, the Kolmogorov "D" statistic (Stephens, 1974) is recommended. An example of the Shapiro-Wilk's test is provided below.

2.2 The example uses growth data from the Sheepshead Minnow Larval Survival and Growth Test. The same data are used in the discussion of the homogeneity of variance determination in Paragraph 3 and Dunnett's Procedure in Appendix C. The data, the mean and variance of the observations at each concentration, including the control, are listed in Table B.1.

2.3 The first step of the test for normality is to center the observations by subtracting the mean of all observations within a concentration from each observation in that concentration. The centered observations are listed in Table B.2.

2.4 Calculate the denominator, D, of the test statistic:

$$D = \sum_{i=1}^n (X_i - \bar{X})^2$$

Where: X_i = the centered observations, \bar{X} is the overall mean of the centered observations, and n is the total number of the centered observations. For this set of data, $\bar{X} = 0$, and $D = 0.1589$.

TABLE B.1. SHEEPSHEAD MINNOW, *CYPRINODON VARIEGATUS*, LARVAL GROWTH DATA (WEIGHT IN MG) FOR THE SHAPIRO-WILK'S TEST

Replicate	Control	Effluent Concentration (%)			
		6.25	12.5	25.0	50.0
1	1.017	1.157	0.998	0.837	0.715
2	0.745	0.914	0.793	0.935	0.907
3	0.862	0.992	1.021	0.839	1.044
Mean(\bar{Y}_i)	0.875	1.021	0.937	0.882	0.889
S_i^2	0.019	0.015	0.016	0.0031	0.027
i	1	2	3	4	5

TABLE B.2. EXAMPLE OF SHAPIRO-WILK'S TEST: CENTERED OBSERVATIONS

Replicate	Control	Effluent Concentration (%)			
		6.25	12.5	25.0	50.0
1	0.142	0.136	0.061	- 0.009	- 0.174
2	- 0.130	- 0.107	- 0.144	0.053	0.018
3	- 0.013	- 0.029	0.084	- 0.043	0.155

2.4.1 For this set of data,

$$n = 15$$

$$\bar{X} = \frac{1}{15} (0) = 0.0$$

$$D = 0.1589$$

2.5 Order the centered observations from smallest to largest,

$$X^{(1)} \leq X^{(2)} \leq \dots \leq X^{(n)}$$

where $X^{(i)}$ denote the i th order statistic. The ordered observations are listed in Table B.3.

TABLE B.3. EXAMPLE OF THE SHAPIRO-WILK'S TEST: ORDERED OBSERVATIONS

i	$X^{(i)}$
1	- 0.174
2	- 0.144
3	- 0.130
4	- 0.107
5	- 0.043
6	- 0.029
7	- 0.013
8	- 0.009
9	0.018
10	0.053
11	0.061
12	0.084
13	0.136
14	0.142
15	0.155

2.6 From Table B.4, for the number of observations, n , obtain the coefficients a_1, a_2, \dots, a_k , where k is $n/2$ if n is even, and $(n-1)/2$ if n is odd. For the data in this example, $n = 15$, $k = 7$, and the a_i values are listed in Table B.5.

2.7 Compute the test statistic, W , as follows:

$$W = \frac{1}{D} \left[\sum_{i=1}^k a_i (X^{(n-i+1)} - X^{(i)}) \right]^2$$

The differences, $X^{(n-i+1)} - X^{(i)}$, are listed in Table B.5.

2.8 The decision rule for this test is to compare the critical value from Table B.6 to the computed W . If the computed value is less than the critical value, conclude that the data are not normally distributed. For this example, the critical value at a significance level of 0.01 and 15 observations (n) is 0.835. The calculated value, 0.9516, is not less than the critical value. Therefore conclude that the data are normally distributed.

TABLE B.4. COEFFICIENTS FOR THE SHAPIRO-WILK'S TEST (Conover, 1980)

i/n	Number of Observations								
	2	3	4	5	6	7	8	9	10
1	0.7071	0.7071	0.6872	0.6646	0.6431	0.6233	0.6052	0.5888	0.5739
2	-	0.0000	0.1667	0.2413	0.2806	0.3031	0.3164	0.3244	0.3291
3	-	-	-	0.0000	0.0875	0.1401	0.1743	0.1976	0.2141
4	-	-	-	-	-	0.0000	0.0561	0.0947	0.1224
5	-	-	-	-	-	-	-	0.0000	0.0399

i/n	Number of Observations									
	11	12	13	14	15	16	17	18	19	20
1	0.5601	0.5475	0.5359	0.5251	0.5150	0.5056	0.4968	0.4886	0.4808	0.4734
2	0.3315	0.3325	0.3325	0.3318	0.3306	0.3290	0.3273	0.3253	0.3232	0.3211
3	0.2260	0.2347	0.2412	0.2460	0.2495	0.2521	0.2540	0.2553	0.2561	0.2565
4	0.1429	0.1586	0.1707	0.1802	0.1878	0.1939	0.1988	0.2027	0.2059	0.2085
5	0.0695	0.0922	0.1099	0.1240	0.1353	0.1447	0.1524	0.1587	0.1641	0.1686
6	0.0000	0.0303	0.0539	0.0727	0.0880	0.1005	0.1109	0.1197	0.1271	0.1334
7	-	-	0.0000	0.0240	0.0433	0.0593	0.0725	0.0837	0.0932	0.1013
8	-	-	-	-	0.0000	0.0196	0.0359	0.0496	0.0612	0.0711
9	-	-	-	-	-	-	0.0000	0.0163	0.0303	0.0422
10	-	-	-	-	-	-	-	-	0.0000	0.0140

i/n	Number of Observations									
	21	22	23	24	25	26	27	28	29	30
1	0.4643	0.4590	0.4542	0.4493	0.4450	0.4407	0.4366	0.4328	0.4291	0.4254
2	0.3185	0.3156	0.3126	0.3098	0.3069	0.3043	0.3018	0.2992	0.2968	0.2944
3	0.2578	0.2571	0.2563	0.2554	0.2543	0.2533	0.2522	0.2510	0.2499	0.2487
4	0.2119	0.2131	0.2139	0.2145	0.2148	0.2151	0.2152	0.2151	0.2150	0.2148
5	0.1736	0.1764	0.1787	0.1807	0.1822	0.1836	0.1848	0.1857	0.1864	0.1870
6	0.1399	0.1443	0.1480	0.1512	0.1539	0.1563	0.1584	0.1601	0.1616	0.1630
7	0.1092	0.1150	0.1201	0.1245	0.1283	0.1316	0.1346	0.1372	0.1395	0.1415
8	0.0804	0.0878	0.0941	0.0997	0.1046	0.1089	0.1128	0.1162	0.1192	0.1219
9	0.0530	0.0618	0.0696	0.0764	0.0823	0.0876	0.0923	0.0965	0.1002	0.1036
10	0.0263	0.0368	0.0459	0.0539	0.0610	0.0672	0.0728	0.0778	0.0822	0.0862
11	0.0000	0.0122	0.0228	0.0321	0.0403	0.0476	0.0540	0.0598	0.0650	0.0697
12	-	-	0.0000	0.0107	0.0200	0.0284	0.0358	0.0424	0.0483	0.0537
13	-	-	-	-	0.0000	0.0094	0.0178	0.0253	0.0320	0.0381
14	-	-	-	-	-	-	0.0000	0.0084	0.0159	0.0227
15	-	-	-	-	-	-	-	-	0.0000	0.0076

TABLE B.4. COEFFICIENTS FOR THE SHAPIRO-WILK'S TEST (CONTINUED)

i/n	Number of Observations									
	31	32	33	34	35	36	37	38	39	40
1	0.4220	0.4188	0.4156	0.4127	0.4096	0.4068	0.4040	0.4015	0.3989	0.3964
2	0.2921	0.2898	0.2876	0.2854	0.2834	0.2813	0.2794	0.2774	0.2755	0.2737
3	0.2475	0.2462	0.2451	0.2439	0.2427	0.2415	0.2403	0.2391	0.2380	0.2368
4	0.2145	0.2141	0.2137	0.2132	0.2127	0.2121	0.2116	0.2110	0.2104	0.2098
5	0.1874	0.1878	0.1880	0.1882	0.1883	0.1883	0.1883	0.1881	0.1880	0.1878
6	0.1641	0.1651	0.1660	0.1667	0.1673	0.1678	0.1683	0.1686	0.1689	0.1691
7	0.1433	0.1449	0.1463	0.1475	0.1487	0.1496	0.1505	0.1513	0.1520	0.1526
8	0.1243	0.1265	0.1284	0.1301	0.1317	0.1331	0.1344	0.1356	0.1366	0.1376
9	0.1066	0.1093	0.1118	0.1140	0.1160	0.1179	0.1196	0.1211	0.1225	0.1237
10	0.0899	0.0931	0.0961	0.0988	0.1013	0.1036	0.1056	0.1075	0.1092	0.1108
11	0.0739	0.0777	0.0812	0.0844	0.0873	0.0900	0.0924	0.0947	0.0967	0.0986
12	0.0585	0.0629	0.0669	0.0706	0.0739	0.0770	0.0798	0.0824	0.0848	0.0870
13	0.0435	0.0485	0.0530	0.0572	0.0610	0.0645	0.0677	0.0706	0.0733	0.0759
14	0.0289	0.0344	0.0395	0.0441	0.0484	0.0523	0.0559	0.0592	0.0622	0.0651
15	0.0144	0.0206	0.0262	0.0314	0.0361	0.0404	0.0444	0.0481	0.0515	0.0546
16	0.0000	0.0068	0.0131	0.0187	0.0239	0.0287	0.0331	0.0372	0.0409	0.0444
17	-	-	0.0000	0.0062	0.0119	0.0172	0.0220	0.0264	0.0305	0.0343
18	-	-	-	-	0.0000	0.0057	0.0110	0.0158	0.0203	0.0244
19	-	-	-	-	-	-	0.0000	0.0053	0.0101	0.0146
20	-	-	-	-	-	-	-	-	0.0000	0.0049

i/n	Number of Observations									
	41	42	43	44	45	46	47	48	49	50
1	0.3940	0.3917	0.3894	0.3872	0.3850	0.3830	0.3808	0.3789	0.3770	0.3751
2	0.2719	0.2701	0.2684	0.2667	0.2651	0.2635	0.2620	0.2604	0.2589	0.2574
3	0.2357	0.2345	0.2334	0.2323	0.2313	0.2302	0.2291	0.2281	0.2271	0.2260
4	0.2091	0.2085	0.2078	0.2072	0.2065	0.2058	0.2052	0.2045	0.2038	0.2032
5	0.1876	0.1874	0.1871	0.1868	0.1865	0.1862	0.1859	0.1855	0.1851	0.1847
6	0.1693	0.1694	0.1695	0.1695	0.1695	0.1695	0.1695	0.1693	0.1692	0.1691
7	0.1531	0.1535	0.1539	0.1542	0.1545	0.1548	0.1550	0.1551	0.1553	0.1554
8	0.1384	0.1392	0.1398	0.1405	0.1410	0.1415	0.1420	0.1423	0.1427	0.1430
9	0.1249	0.1259	0.1269	0.1278	0.1286	0.1293	0.1300	0.1306	0.1312	0.1317
10	0.1123	0.1136	0.1149	0.1160	0.1170	0.1180	0.1189	0.1197	0.1205	0.1212
11	0.1004	0.1020	0.1035	0.1049	0.1062	0.1073	0.1085	0.1095	0.1105	0.1113
12	0.0891	0.0909	0.0927	0.0943	0.0959	0.0972	0.0986	0.0998	0.1010	0.1020
13	0.0782	0.0804	0.0824	0.0842	0.0860	0.0876	0.0892	0.0906	0.0919	0.0932
14	0.0677	0.0701	0.0724	0.0745	0.0765	0.0783	0.0801	0.0817	0.0832	0.0846
15	0.0575	0.0602	0.0628	0.0651	0.0673	0.0694	0.0713	0.0731	0.0748	0.0764
16	0.0476	0.0506	0.0534	0.0560	0.0584	0.0607	0.0628	0.0648	0.0667	0.0685
17	0.0379	0.0411	0.0442	0.0471	0.0497	0.0522	0.0546	0.0568	0.0588	0.0608
18	0.0283	0.0318	0.0352	0.0383	0.0412	0.0439	0.0465	0.0489	0.0511	0.0532
19	0.0188	0.0227	0.0263	0.0296	0.0328	0.0357	0.0385	0.0411	0.0436	0.0459
20	0.0094	0.0136	0.0175	0.0211	0.0245	0.0277	0.0307	0.0335	0.0361	0.0386
21	0.0000	0.0045	0.0087	0.0126	0.0163	0.0197	0.0229	0.0259	0.0288	0.0314
22	-	-	0.0000	0.0042	0.0081	0.0118	0.0153	0.0185	0.0215	0.0244
23	-	-	-	-	0.0000	0.0039	0.0076	0.0111	0.0143	0.0174
24	-	-	-	-	-	-	0.0000	0.0037	0.0071	0.0104
25	-	-	-	-	-	-	-	-	0.0000	0.0035

TABLE B.5. EXAMPLE OF THE SHAPIRO-WILK'S TEST:
TABLE OF COEFFICIENTS AND DIFFERENCES

i	a _i	$\chi^{(n-i+1)} - \chi^{(i)}$	
1	0.5150	0.329	$X^{(14)} - X^{(1)}$
2	0.3306	0.286	$X^{(13)} - X^{(2)}$
3	0.2495	0.266	$X^{(12)} - X^{(3)}$
4	0.1878	0.191	$X^{(11)} - X^{(4)}$
5	0.1353	0.104	$X^{(10)} - X^{(5)}$
6	0.0880	0.082	$X^{(09)} - X^{(6)}$
7	0.0433	0.031	$X^{(08)} - X^{(7)}$

2.9 In general, if the data fail the test for normality, a transformation such as to log values may normalize the data. After transforming the data, repeat the Shapiro Wilk's Test for normality.

3. TEST FOR HOMOGENEITY OF VARIANCE

3.1 For Dunnett's Procedure and the t test with Bonferroni's adjustment, the variances of the data obtained from each toxicant concentration and the control are assumed to be equal. Bartlett's Test is a formal test of this assumption. In using this test, it is assumed that the data are normally distributed.

3.2 The data used in this example are growth data from a Sheepshead Minnow Larval Survival and Growth Test, and are the same data used in Appendices C and D. These data are listed in Table B.7, together with the calculated variance for the control and each toxicant concentration.

3.3 The test statistic for Bartlett's Test (Snedecor and Cochran, 1980) is as follows:

$$B = \frac{[(\sum_{i=1}^p V_i) \ln \bar{S}^2 - \sum_{i=1}^p V_i \ln S_i^2]}{C}$$

Where: V_i = degrees of freedom for each effluent concentration and control, ($V_i = n_i - 1$)

p = number of levels of toxicant concentration including the control

\ln = \log_e

TABLE B.6. QUANTILES OF THE SHAPIRO WILK'S TEST STATISTIC (Conover, 1980)

n	0.01	0.02	0.05	0.10	0.50	0.90	0.95	0.98	0.99
3	0.753	0.756	0.767	0.789	0.959	0.998	0.999	1.000	1.000
4	0.687	0.707	0.748	0.792	0.935	0.987	0.992	0.996	0.997
5	0.686	0.715	0.762	0.806	0.927	0.979	0.986	0.991	0.993
6	0.713	0.743	0.788	0.826	0.927	0.974	0.981	0.986	0.989
7	0.730	0.760	0.803	0.838	0.928	0.972	0.979	0.985	0.988
8	0.749	0.778	0.818	0.851	0.932	0.972	0.978	0.984	0.987
9	0.764	0.791	0.829	0.859	0.935	0.972	0.978	0.984	0.986
10	0.781	0.806	0.842	0.869	0.938	0.972	0.978	0.983	0.986
11	0.792	0.817	0.850	0.876	0.940	0.973	0.979	0.984	0.986
12	0.805	0.828	0.859	0.883	0.943	0.973	0.979	0.984	0.986
13	0.814	0.837	0.866	0.889	0.945	0.974	0.979	0.984	0.986
14	0.825	0.846	0.874	0.895	0.947	0.975	0.980	0.984	0.986
15	0.835	0.855	0.881	0.901	0.950	0.975	0.980	0.984	0.987
16	0.844	0.863	0.887	0.906	0.952	0.976	0.981	0.985	0.987
17	0.851	0.869	0.892	0.910	0.954	0.977	0.981	0.985	0.987
18	0.858	0.874	0.897	0.914	0.956	0.978	0.982	0.986	0.988
19	0.863	0.879	0.901	0.917	0.957	0.978	0.982	0.986	0.988
20	0.868	0.884	0.905	0.920	0.959	0.979	0.983	0.986	0.988
21	0.873	0.888	0.908	0.923	0.960	0.980	0.983	0.987	0.989
22	0.878	0.892	0.911	0.926	0.961	0.980	0.984	0.987	0.989
23	0.881	0.895	0.914	0.928	0.962	0.981	0.984	0.987	0.989
24	0.884	0.898	0.916	0.930	0.963	0.981	0.984	0.987	0.989
25	0.888	0.901	0.918	0.931	0.964	0.981	0.985	0.988	0.989
26	0.891	0.904	0.920	0.933	0.965	0.982	0.985	0.988	0.989
27	0.894	0.906	0.923	0.935	0.965	0.982	0.985	0.988	0.990
28	0.896	0.908	0.924	0.936	0.966	0.982	0.985	0.988	0.990
29	0.898	0.910	0.926	0.937	0.966	0.982	0.985	0.988	0.990
30	0.900	0.912	0.927	0.939	0.967	0.983	0.985	0.988	0.990
31	0.902	0.914	0.929	0.940	0.967	0.983	0.986	0.988	0.990
32	0.904	0.915	0.930	0.941	0.968	0.983	0.986	0.988	0.990
33	0.906	0.917	0.931	0.942	0.968	0.983	0.986	0.989	0.990
34	0.908	0.919	0.933	0.943	0.969	0.983	0.986	0.989	0.990
35	0.910	0.920	0.934	0.944	0.969	0.984	0.986	0.989	0.990
36	0.912	0.922	0.935	0.945	0.970	0.984	0.986	0.989	0.990
37	0.914	0.924	0.936	0.946	0.970	0.984	0.987	0.989	0.990
38	0.916	0.925	0.938	0.947	0.971	0.984	0.987	0.989	0.990
39	0.917	0.927	0.939	0.948	0.971	0.984	0.987	0.989	0.991
40	0.919	0.928	0.940	0.949	0.972	0.985	0.987	0.989	0.991
41	0.920	0.929	0.941	0.950	0.972	0.985	0.987	0.989	0.991
42	0.922	0.930	0.942	0.951	0.972	0.985	0.987	0.989	0.991
43	0.923	0.932	0.943	0.951	0.973	0.985	0.987	0.990	0.991
44	0.924	0.933	0.944	0.952	0.973	0.985	0.987	0.990	0.991
45	0.926	0.934	0.945	0.953	0.973	0.985	0.988	0.990	0.991
46	0.927	0.935	0.945	0.953	0.974	0.985	0.988	0.990	0.991
47	0.928	0.936	0.946	0.954	0.974	0.985	0.988	0.990	0.991
48	0.929	0.937	0.947	0.954	0.974	0.985	0.988	0.990	0.991
49	0.929	0.937	0.947	0.955	0.974	0.985	0.988	0.990	0.991
50	0.930	0.938	0.947	0.955	0.974	0.985	0.988	0.990	0.991

$i = 1, 2, \dots, p$ where p is the number of concentrations including the control

$n_i =$ the number of replicates for concentration i .

$$\bar{S}^2 = \frac{(\sum_{i=1}^p V_i S_i^2)}{\sum_{i=1}^p V_i}$$

$$C = 1 + [3(p-1)]^{-1} [\sum_{i=1}^p 1/V_i - (\sum_{i=1}^p V_i)^{-1}]$$

TABLE B.7. SHEEPSHEAD MINNOW, *CYPRINODON VARIEGATUS*, LARVAL GROWTH DATA (WEIGHT IN MG) USED FOR BARTLETT'S TEST FOR HOMOGENEITY OF VARIANCE

Replicate	Control	Effluent Concentration (%)			
		6.25	12.5	25.0	50.0
1	1.017	1.157	0.998	0.837	0.715
2	0.745	0.914	0.793	0.935	0.907
3	0.862	0.992	1.021	0.839	1.044
Mean	0.875	1.021	0.937	0.882	0.889
S_i^2	0.019	0.015	0.016	0.0031	0.027
i	1	2	3	4	5

3.4 Since B is approximately distributed as chi-square with $p - 1$ degrees of freedom when the variances are equal, the appropriate critical value is obtained from a table of the chi-square distribution for $p - 1$ degrees of freedom and a significance level of 0.01. If B is less than the critical value then the variances are assumed to be equal.

3.5 For the data in this example, $V_i = 2$, $p = 5$, $\bar{S}^2 = 0.0158$, and $C = 1.2$. The calculated B value is:

$$B = \frac{2 [5 (\ln 0.0158) - \sum_i \ln (S_i^2)]}{1.2}$$

$$= \frac{2 [5(-4.1477) - (-22.1247)]}{1.2}$$

$$= 2.3103$$

3.6 Since B is approximately distributed as chi-square with $p - 1$ degrees of freedom when the variances are equal, the appropriate critical value for the test is 13.3 for a significance level of 0.01. Since B is less than 13.3, the conclusion is that the variances are not different.

4. TRANSFORMATIONS OF THE DATA

4.1 When the assumptions of normality and/or homogeneity of variance are not met, transformations of the data may remedy the problem, so that the data can be analyzed by parametric procedures, rather than nonparametric technique such as Steel's Many-one Rank Test or Wilcoxon's Rank Sum Test. Examples of transformations include log, square root, arc sine square root, and reciprocals. After the data have been transformed, the Shapiro-Wilk's and Bartlett's tests should be performed on the transformed observations to determine whether the assumptions of normality and/or homogeneity of variance are met.

4.2 ARC SINE SQUARE ROOT TRANSFORMATION (USEPA, 1993).

4.2.1 For data consisting of proportions from a binomial (response/no response; live/dead) response variable, the variance within the i th treatment is proportional to $P_i (1 - P_i)$, where P_i is the expected proportion for the treatment. This clearly violates the homogeneity of variance assumption required by parametric procedures such as Dunnett's Procedure or the t test with Bonferroni's adjustment, since the existence of a treatment effect implies different values of P_i for different treatments, i . Also, when the observed proportions are based on small samples, or when P_i is close to zero or one, the normality assumption may be invalid. The arc sine square root ($\text{arc sine } \sqrt{P}$) transformation is commonly used for such data to stabilize the variance and satisfy the normality requirement.

4.2.2 Arc sine transformation consists of determining the angle (in radians) represented by a sine value. In the case of arc sine square root transformation of mortality data, the proportion of dead (or affected) organisms is taken as the sine value, the square root of the sine value is determined, and the angle (in radians) for the square root of the sine value is determined. Whenever the proportion dead is 0 or 1, a special modification of the arc sine square root transformation must be used (Bartlett, 1937). An explanation of the arc sine square root transformation and the modification is provided below.

4.2.3 Calculate the response proportion (RP) at each effluent concentration, where:

$$RP = (\text{number of surviving or unaffected organisms}) / (\text{number exposed}).$$

Example: If 12 of 20 animals in a given treatment replicate survive:

$$RP = 12/20$$

$$= 0.60$$

4.2.4 Transform each RP to its arc sine square root, as follows:

4.2.4.1 For RPs greater than zero or less than one:

$$\text{Angle (radians)} = \sqrt{RP}$$

Example: If RP = 0.60:

$$\begin{aligned}\text{Angle} &= \text{arc sine } \sqrt{0.60} \\ &= \text{arc sine } 0.7746 \\ &= 0.8861 \text{ radians}\end{aligned}$$

4.2.4.2 Modification of the arc sine square root when RP = 0.

$$\text{Angle (in radians)} = \text{arc sine } \sqrt{1/4N}$$

Where: N = Number of animals/treatment replicate

Example: If 20 animals are used:

$$\begin{aligned}\text{Angle} &= \text{arc sine } \sqrt{1/80} \\ &= \text{arc sine } 0.1118 \\ &= 0.1120 \text{ radians}\end{aligned}$$

4.2.4.3 Modification of the arc sine square root when RP = 0

$$\text{Angle} = 1.5708 \text{ radians} - (\text{radians for } RP = 0)$$

Example: Using above value:

$$\begin{aligned}\text{Angle} &= 1.5708 - 0.1120 \\ &= 1.4588 \text{ radians}\end{aligned}$$

APPENDIX C

DUNNETT'S PROCEDURE

1. MANUAL CALCULATIONS

1.1 Dunnett's Procedure (Dunnett, 1955; Dunnett, 1964) is used to compare each concentration mean with the control mean to decide if any of the concentrations differ from the control. This test has an overall error rate of alpha, which accounts for the multiple comparisons with the control. It is based on the assumptions that the observations are independent and normally distributed and that the variance of the observations is homogeneous across all concentrations and control. (See Appendix B for a discussion on validating the assumptions). Dunnett's Procedure uses a pooled estimate of the variance, which is equal to the error value calculated in an analysis of variance. Dunnett's Procedure can only be used when the same number of replicate test vessels have been used at each concentration and the control. When this condition is not met, the t test with Bonferroni's adjustment is used (see Appendix D).

1.2 The data used in this example are growth data from a Sheepshead Minnow Larval Survival and Growth Test, and are the same data used in Appendices B and D. These data are listed in Table C.1.

TABLE C.1. SHEEPSHEAD MINNOW, *CYPRINODON VARIEGATUS*, LARVAL GROWTH DATA (WEIGHT IN MG) USED FOR DUNNETT'S PROCEDURE

Effluent Conc (%)	i	Replicate Test Vessel			Total (T _i)	Mean (\bar{Y}_i)
		1	2	3		
Control	1	1.017	0.745	0.862	2.624	0.875
6.25	2	1.157	0.914	0.992	3.063	1.021
12.5	3	0.998	0.793	1.021	2.812	0.937
25.0	4	0.873	0.935	0.839	2.647	0.882
50.0	5	0.715	0.907	1.044	2.666	0.889

1.3 One way to obtain an estimate of the pooled variance is to construct an ANOVA table including all sums of squares, using the following formulas:

Where: p = number of effluent concentrations including the control:

N = the total sample size; $N = \sum_i n_i$

n_i = the number of replicates for concentration "i"

$SST = \sum_{ij} Y_{ij}^2 - G^2/N$ Total Sum of Squares

$SSB = \sum_i T_i^2/n_i - G^2/N$ Between Sum of Squares

$SSW = SST - SSB$ Within Sum of Squares

G = the grand total of all sample observations; $G = \sum_{i=1}^p T_i$

T_i = the total of the replicate measurements for concentration i

N = the total sample size; $N = \sum_i n_i$

n_i = the number of replicates for concentration i

Y_{ij} = the j th observation for concentration i

1.4 For the data in this example:

$$n_1 = n_2 = n_3 = n_4 = n_5 = 3$$

$$N = 20$$

$$T_1 = Y_{11} + Y_{12} + Y_{13} = 2.624$$

$$T_2 = Y_{21} + Y_{22} + Y_{23} = 3.063$$

$$T_3 = Y_{31} + Y_{32} + Y_{33} = 2.812$$

$$T_4 = Y_{41} + Y_{42} + Y_{43} = 2.647$$

$$T_5 = Y_{51} + Y_{52} + Y_{53} = 2.666$$

$$G = T_1 + T_2 + T_3 + T_4 + T_5 = 13.812$$

$$\begin{aligned}
 SST &= \sum_{ij} Y_{ij}^2 - G^2/N \\
 &= 12.922 - (13.812)^2/15 \\
 &= 0.204
 \end{aligned}$$

$$\begin{aligned}
 SSB &= \sum_i T_i^2/n_i - G^2/N \\
 &= 12.763 - (13.812)^2/15 \\
 &= 0.045
 \end{aligned}$$

$$\begin{aligned}
 SSW &= SST - SSB \\
 &= 0.204 - 0.045 \\
 &= 0.159
 \end{aligned}$$

1.5 Summarize these data in the ANOVA table (Table C.2).

TABLE C.2. ANOVA TABLE FOR DUNNETT'S PROCEDURE

Source	df	Sum of Squares (SS)	Mean Square (MS) (SS/df)
Between	p - 1	SSB	$S_B^2 = SSB/(p-1)$
Within	N - p	SSW	$S_W^2 = SSW/(N-p)$
Total	N - 1	SST	

1.6 Summarize data for ANOVA (Table C.3).

TABLE C.3. COMPLETED ANOVA TABLE FOR DUNNETT'S PROCEDURE

Source	df	SS	Mean Square
Between	5 - 1 = 4	0.045	0.011
Within	15 - 5 = 10	0.159	0.016
Total	14	0.204	

1.7 To perform the individual comparisons, calculate the t statistic for each concentration and control combination, as follows:

$$t_i = \frac{(\bar{Y}_1 - \bar{Y}_i)}{S_w \sqrt{(1/n_1) + (1/n_i)}}$$

Where: \bar{Y}_i = mean for each concentration i.

\bar{Y}_1 = mean for the control

S_w = square root of the within mean square

n_1 = number of replicates in the control.

n_i = number of replicates for concentration i.

1.8 Table C.4 includes the calculated t values for each concentration and control combination.

TABLE C.4. CALCULATED T VALUES

Effluent Concentration (%)	i	t _i
6.25	2	- 1.414
12.5	3	- 0.600
25.0	4	- 0.068
50.0	5	- 0.136

1.9 Since the purpose of the test is only to detect a decrease in growth from the control, a one-sided test is appropriate. The critical value for the one-sided comparison (2.47), with an overall alpha level of 0.05, 10 degrees of freedom and four concentrations excluding the control is read from the table of Dunnett's "T" values (Table C.5; this table assumes an equal number of replicates in all treatment concentrations and the control). Comparing each of the calculated t values in Table C.4 with the critical value, no decreases in growth from the control were detected. Thus the NOEC is 50.0%.

1.10 To quantify the sensitivity of the test, the minimum significant difference (MSD) may be calculated. The formula is as follows:

$$MSD = d S_w \sqrt{(1/n_1) + (1/n)}$$

Where: d = critical value for the Dunnett's Procedure

S_w = the square root of the within mean square

n = the number of replicates at each concentration, assuming an equal number of replicates at all treatment concentrations

n₁ = number of replicates in the control

For example:

$$\begin{aligned} MSD &= 2.47 (0.126) [\sqrt{(1/3) + (1/3)}] = 2.47 (0.126) (\sqrt{2/3}) \\ &= 2.47 (0.126)(0.816) \\ &= 0.254 \end{aligned}$$

TABLE C.5. DUNNETT'S "T" VALUES (Miller, 1981)

		(One-tailed) d'_{k}																	
v	k	$\alpha = .05$									$\alpha = 0.1$								
		1	2	3	4	5	6	7	8	9	1	2	3	4	5	6	7	8	9
5		2.02	2.44	2.58	2.85	2.98	3.08	3.18	3.24	3.30	3.37	3.90	4.21	4.43	4.50	4.73	4.85	4.94	5.03
6		1.94	2.34	2.56	2.71	2.83	2.92	3.00	3.07	3.12	3.14	3.61	4.08	4.07	4.21	4.33	4.43	4.51	4.59
7		1.89	2.27	2.48	2.62	2.72	2.82	2.89	2.95	3.01	3.00	3.42	3.56	3.83	3.98	4.07	4.15	4.23	4.30
8		1.86	2.22	2.42	2.55	2.66	2.74	2.81	2.87	2.92	2.90	3.20	3.51	3.67	3.79	3.88	3.96	4.03	4.09
9		1.83	2.18	2.37	2.50	2.60	2.68	2.75	2.81	2.86	2.82	3.19	3.40	3.55	3.64	3.75	3.82	3.89	3.94
10		1.81	2.15	2.34	2.47	2.56	2.64	2.70	2.76	2.81	2.76	3.11	3.31	3.45	3.54	3.64	3.71	3.78	3.83
11		1.80	2.13	2.31	2.44	2.53	2.60	2.67	2.72	2.77	2.72	3.06	3.25	3.39	3.46	3.58	3.63	3.69	3.74
12		1.78	2.11	2.29	2.41	2.50	2.58	2.64	2.69	2.74	2.68	3.01	3.19	3.32	3.42	3.50	3.56	3.62	3.67
13		1.77	2.09	2.27	2.39	2.48	2.55	2.61	2.68	2.71	2.65	2.97	3.15	3.27	3.37	3.44	3.51	3.56	3.61
14		1.76	2.08	2.25	2.37	2.46	2.53	2.59	2.64	2.69	2.62	2.94	3.11	3.23	3.32	3.40	3.46	3.51	3.56
15		1.75	2.07	2.24	2.36	2.44	2.51	2.57	2.62	2.67	2.60	2.91	3.08	3.20	3.29	3.36	3.42	3.47	3.52
16		1.75	2.06	2.23	2.34	2.43	2.50	2.56	2.61	2.65	2.58	2.88	3.05	3.17	3.26	3.33	3.39	3.44	3.49
17		1.74	2.05	2.22	2.33	2.42	2.49	2.54	2.59	2.64	2.57	2.86	3.03	3.14	3.23	3.30	3.36	3.41	3.45
18		1.73	2.04	2.21	2.32	2.41	2.48	2.53	2.58	2.62	2.55	2.84	3.01	3.12	3.21	3.27	3.33	3.38	3.42
19		1.73	2.03	2.20	2.31	2.40	2.47	2.52	2.57	2.61	2.54	2.83	2.99	3.10	3.18	3.25	3.31	3.36	3.40
20		1.72	2.03	2.19	2.30	2.38	2.46	2.51	2.56	2.60	2.53	2.81	2.97	3.08	3.17	3.23	3.29	3.34	3.38
24		1.71	2.01	2.17	2.28	2.36	2.43	2.48	2.53	2.57	2.40	2.77	2.92	3.03	3.11	3.17	3.22	3.27	3.31
30		1.70	1.99	2.15	2.25	2.33	2.40	2.45	2.50	2.54	2.46	2.72	2.87	2.97	3.05	3.11	3.16	3.21	3.24
40		1.68	1.97	2.13	2.23	2.31	2.37	2.42	2.47	2.51	2.42	2.68	2.82	2.92	2.99	3.06	3.10	3.14	3.18
60		1.67	1.95	2.10	2.21	2.28	2.35	2.39	2.44	2.48	2.39	2.64	2.78	2.87	2.94	3.00	3.04	3.06	3.12
120		1.66	1.93	2.08	2.18	2.26	2.32	2.37	2.41	2.45	2.36	2.60	2.73	2.82	2.90	2.94	2.99	3.03	3.08
∞		1.64	1.92	2.06	2.16	2.23	2.29	2.34	2.38	2.42	2.33	2.56	2.68	2.77	2.84	2.90	2.93	2.97	3.00

424

20424

1.11 For this set of data, the minimum difference between the control mean and a concentration mean that can be detected as statistically significant is 0.254 mg. This represents a decrease in growth of 29% from the control.

1.11.1 If the data have not been transformed, the MSD (and the percent decrease from the control mean that it represents) can be reported as is.

1.11.2 In the case where the data have been transformed, the MSD would be in transformed units. In this case carry out the following conversion to determine the MSD in untransformed units.

1.11.2.1 Subtract the MSD from the transformed control mean. Call this difference D. Next, obtain untransformed values for the control mean and the difference, D.

$$MSD_u = control_u - D_u$$

Where: MSD_u = the minimum significant difference for untransformed data

$Control_u$ = the untransformed control mean

D_u = the untransformed difference

1.11.2.2 Calculate the percent reduction from the control that MSD_u represents as:

$$\text{Percent Reduction} = \frac{MSD_u}{Control_u} \times 100$$

1.11.3 An example of a conversion of the MSD to untransformed units, when the arc sine square root transformation was used on the data, follows.

Step 1. Subtract the MSD from the transformed control mean. As an example, assume the data in Table C.1 were transformed by the arc sine square root transformation. Thus:

$$0.875 - 0.254 = 0.621$$

Step 2. Obtain untransformed values for the control mean (0.875) and the difference (0.621) obtained in Step 1, above.

$$[\text{Sine}(0.875)]^2 = 0.589$$

$$[\text{Sine}(0.621)]^2 = 0.339$$

Step 3. The untransformed MSD (MSD_u) is determined by subtracting the untransformed values obtained in Step 2.

$$MSD_u = 0.589 - 0.339 = 0.250$$

In this case, the MSD would represent a 42% decrease in survival from the control $[(0.250/0.589)(100)]$.

2. COMPUTER CALCULATIONS

2.1 This computer program incorporates two analyses: an analysis of variance (ANOVA), and a multiple comparison of treatment means with the control mean (Dunnett's Procedure). The ANOVA is used to obtain the error value. Dunnett's Procedure indicates which toxicant concentration means (if any) are statistically different from the control mean at the 5% level of significance. The program also provides the minimum difference between the control and treatment means that could be detected as statistically significant, and tests the validity of the homogeneity of variance assumption by Bartlett's Test. The multiple comparison is performed based on procedures described by Dunnett (1955).

2.2 The source code for the Dunnett's program is structured into a series of subroutines, controlled by a driver routine. Each subroutine has a specific function in the Dunnett's Procedure, such as data input, transforming the data, testing for equality of variances, computing p values, and calculating the one-way analysis of variance.

2.3 The program compares up to seven toxicant concentrations against the control, and can accommodate up to 50 replicates per concentration.

2.4 If the number of replicates at each toxicant concentration and control are not equal, a t test with the Bonferroni adjustment is performed instead of Dunnett's Procedure (see Appendix D).

2.5 The program was written in IBM-PC FORTRAN by Computer Sciences Corporation, 26 W. Martin Luther King Drive, Cincinnati, OH 45268. A compiled version of the program can be obtained from EMSL-Cincinnati by sending a diskette with a written request.

2.6 DATA INPUT AND OUTPUT

2.6.1 Data on the number of surviving mysids, *Mysidopsis bahia*, from a survival, growth and fecundity test (Table C.6) are used to illustrate the data input and output for this program.

2.6.2 Data Input

2.6.2.1 When the program is entered, the user is asked to select the type of data to be analyzed:

1. Response proportions, like survival or fertilization proportions data.
2. Counts and measurements, like offspring counts, cystocarp and algal cell counts, weights, chlorophyll measurements or turbidity measurements.

2.6.2.2 After the type of analysis for the data is chosen, the user has the following options:

1. Create a data file
2. Edit a data file
3. Perform analysis on existing data set
4. Stop

2.6.2.3 When Option 1 (Create a data file) is selected for response proportions, the program prompts the user for the following information:

1. Number of concentrations, including control
2. For each concentration and replicate:
 - number of organisms exposed per replicate
 - number of organisms responding per replicate (organisms surviving, eggs fertilized, etc.)

2.6.2.4 After the data have been entered, the user may save the file on a disk, and the program returns to the main menu (see below).

2.6.2.5 Sample data input is shown in Figure C.1.

2.6.3. Program Output

2.6.3.1 When Option 3 (perform analysis on existing data set) is selected from the menu, the user is asked to select the transformation desired, and indicate whether they expect the means of the test groups to be less or greater than the mean for the control group (see Figure C.2).

2.6.3.2 Summary statistics (Figure C.3) for the raw and transformed data, if applicable, the ANOVA table, results of Bartlett's Test, the results of the multiple comparison procedure, and the minimum detectable difference are included in the program output.

TABLE C.6. SAMPLE DATA FOR DUNNETT'S PROGRAM FOR SURVIVING MYSIDS,
MYSIDOPSIS BAHIA

Treatment	Replicate Chamber	Total Mysids	No. Alive
1 Control	1	5	4
	2	5	4
	3	5	5
	4	5	5
	5	5	5
	6	5	5
	7	5	5
	8	5	4
2 50 ppb	1	5	4
	2	5	5
	3	5	4
	4	5	4
	5	5	5
	6	5	5
	7	5	4
	8	5	5
3 100 ppb	1	5	3
	2	5	5
	3	5	5
	4	5	5
	5	5	5
	6	5	3
	7	5	4
	8	4	4
4 210 ppb	1	5	5
	2	5	4
	3	5	1
	4	5	4
	5	5	3
	6	5	4
	7	5	4
	8	5	4
5 450 ppb	1	5	0
	2	5	1
	3	5	0
	4	5	1
	5	5	0
	6	5	0
	7	5	0
	8	5	2

EMSL Cincinnati Dunnett Software
Version 1.5

- 1) Create a data file
- 2) Edit a data file
- 3) Analyze an existing data set
- 4) Stop

Your choice ? 3

Number of concentrations, including control ? 5

Number of replicates for conc. 1 (the control) ? 8

replicate	number of organisms exposed	number of organisms responding (organisms surviving, eggs fertilized, etc.)
1	5	4
2	5	4
3	5	5
4	5	5
5	5	5
6	5	5
7	5	5
8	5	4

Number of replicates for conc. 2 ? 8

Do you wish to save the data on disk ? y

Disk file for output ? mysidsur.dat

Figure C.1. Sample Data Input for Dunnett's Program for Survival Data from Table C.6.

EMSL Cincinnati: Dunnett Software
Version 1.5

- 1) Create a data file
- 2) Edit a data file
- 3) Analyze an existing data set
- 4) Stop

Your choice ? 3

File name ? mysidsur.dat

Available Transformations

- 1) no transform
- 2) square root
- 3) log10
- 4) arcsine square root

Your choice ? 4

Dunnett's test as implemented in this program is a one-sided test. You must specify the direction the test is to be run; that is, do you expect the means for the test concentrations to be less than or greater than the mean for the control concentration.

Direction for Dunnetts test : L=less than, G=greater than ? 1

Summary Statistics for Raw Data

Conc.	n	Mean	s.d.	cv%
1 = control	8	.9250	.1035	11.2
2	8	.9000	.1069	11.9
3	8	.8500	.1773	20.9
4	8	.7250	.2375	32.8
5	8	.1000	.1512	151.2

Mysid Survival Example with Data in Table C.6

Figure C.2. Example of Choosing Option 3 from the Main Menu of the Dunnett Program.

Mysid Survival Example with Data in Table C.6

Summary Statistics and ANOVA

Transformation = Arcsine Square Root

Conc.	n	Mean	s.d.	cv%
1 = control	8	1.2560	.1232	9.8
2	8	1.2262	.1273	10.4
3	8	1.1709	.2042	17.4
4*	8	1.0288	.2593	25.2
5*	8	.3424	.1752	51.2

*) the mean for this conc. is significantly less than the control mean at alpha = 0.05 (1-sided) by Dunnett's test

Minimum detectable difference for Dunnett's test = -.208074
 This corresponds to a difference of -.153507 in original units
 This difference corresponds to -16.98 percent of control

Between concentrations
 sum of squares = 4.632112 with 4 degrees of freedom.

Error mean square = .034208 with 35 degrees of freedom.

Bartlett's test p-value for equality of variances = .257

Do you wish to restart the program ?

Figure C.3. Example of Program Output for the Dunnett's Program Using the Survival Data in Table C.6.

APPENDIX D

T TEST WITH BONFERRONI'S ADJUSTMENT

1. The t test with Bonferroni's adjustment is used as an alternative to Dunnett's Procedure when the number of replicates is not the same for all concentrations. This test sets an upper bound of alpha on the overall error rate, in contrast to Dunnett's Procedure, for which the overall error rate is fixed at alpha. Thus, Dunnett's Procedure is a more powerful test.
2. The t test with Bonferroni's adjustment is based on the same assumptions of normality of distribution and homogeneity of variance as Dunnett's Procedure (See Appendix B for testing these assumptions), and, like Dunnett's Procedure, uses a pooled estimate of the variance, which is equal to the error value calculated in an analysis of variance.
3. An example of the use of the t test with Bonferroni's adjustment is provided below. The data used in the example are the same as in Appendix C, except that the third replicate from the 50% effluent treatment is presumed to have been lost. Thus, Dunnett's Procedure cannot be used. The weight data are presented in Table D.1.

TABLE D.1. SHEEPSHEAD MINNOW, *CYPRINODON VARIEGATUS*, LARVAL GROWTH DATA (WEIGHT IN MG) USED FOR THE T TEST WITH BONFERRONI'S ADJUSTMENT

Effluent Conc (%)	i	Replicate Test Vessel			Total (T _i)	Mean (\bar{Y}_i)
		1	2	3		
Control	1	1.017	0.745	0.862	2.624	0.875
6.25	2	1.157	0.914	0.992	3.063	1.021
12.5	3	0.998	0.793	1.021	2.812	0.937
25.0	4	0.873	0.935	0.839	2.647	0.882
50.0	5	0.715	0.907	(Lost)	1.622	0.811

3.1 One way to obtain an estimate of the pooled variance is to construct an ANOVA table including all sums of squares, using the following formulas:

Where: p = number of effluent concentrations including the control

N = the total sample size; $N = \sum_i n_i$

n_i = the number of replicates for concentration i

$$SST = \sum_{ij} Y_{ij}^2 - G^2/N \quad \text{Total Sum of Squares}$$

$$SSB = \sum_i T_i^2/n_i - G^2/N \quad \text{Between Sum of Squares}$$

$$SSW = SST - SSB \quad \text{Within Sum of Squares}$$

Where: G = The grand total of all sample observations; $G = \sum_{i=1}^p T_i$

T_i = The total of the replicate measurements for concentration i

Y_{ij} = The j th observation for concentration i

3.2 For the data in this example:

$$n_1 = n_2 = n_3 = n_4 = 3$$

$$N = 20$$

$$T_1 = Y_{11} + Y_{12} + Y_{13} = 2.624$$

$$T_2 = Y_{21} + Y_{22} + Y_{23} = 3.063$$

$$T_3 = Y_{31} + Y_{32} + Y_{33} = 2.812$$

$$T_4 = Y_{41} + Y_{42} + Y_{43} = 2.647$$

$$T_5 = Y_{51} + Y_{52} + Y_{53} = 1.622$$

$$G = T_1 + T_2 + T_3 + T_4 + T_5 = 12.768$$

$$SSB = \sum_i T_i^2/n_i - G^2/N$$

$$= 11.709 - (12.768)^2/14$$

$$= 0.064$$

$$SST = \sum_{ij} Y_{ij}^2 - G^2/N$$

$$= 11.832 - (12.768)^2/14$$

$$= 0.188$$

$$SSW = SST - SSB$$

$$= 0.188 - 0.064$$

$$= 0.124$$

3.3 Summarize these data in the ANOVA table (Table D.2):

TABLE D.2. ANOVA TABLE FOR BONFERRONI'S ADJUSTMENT

Source	df	Sum of Squares (SS)	Mean Square (MS) (SS/df)
Between	$p - 1$	SSB	$S_B^2 = SSB/(p-1)$
Within	$N - p$	SSW	$S_W^2 = SSW/(N-p)$
Total	$N - 1$	SST	

3.4 Summarize these calculations in the ANOVA table (Table D.3):

TABLE D.3. COMPLETED ANOVA TABLE FOR THE T TEST WITH BONFERRONI'S ADJUSTMENT

Source	df	SS	Mean Square
Between	$5 - 1 = 4$	0.064	0.016
Within	$14 - 5 = 9$	0.124	0.014
Total	13	0.188	

3.5 To perform the individual comparisons, calculate the t statistic for each concentration and control combination, as follows:

$$t_i = \frac{(\bar{Y}_1 - \bar{Y}_i)}{S_w \sqrt{(1/n_1) + (1/n_i)}}$$

Where: \bar{Y}_1 = mean for concentration i

\bar{Y}_1 = mean for the control

S_w = square root of the within mean square

n_1 = number of replicates in the control.

n_i = number of replicates for concentration i.

3.6 Table D.4 includes the calculated t values for each concentration and control combination.

TABLE D.4. CALCULATED T VALUES

Effluent Concentration (%)	i	t_i
6.25	2	- 1.511
12.5	3	- 0.642
25.0	4	- 0.072
50.0	5	- 0.592

3.7 Since the purpose of the test is only to detect a decrease in growth from the control, a one-sided test is appropriate. The critical value for the one-sided comparison (2.686), with an overall alpha level of 0.05, nine degrees of freedom and four concentrations excluding the control, was obtained from Table D.5. Comparing each of the calculated t values in Table D.4 with the critical value, no decreases in growth from the control were detected. Thus the NOEC is 50.0%.

TABLE D.5. CRITICAL VALUES FOR "T" FOR THE T TEST WITH BONFERRONI'S ADJUSTMENT P = 0.05
CRITICAL LEVEL, ONE TAILED

d.f.	K = 1	K = 2	K = 3	K = 4	K = 5	K = 6	K = 7	K = 8	K = 9	K = 10
1	6.314	12.707	19.002	25.452	31.821	38.189	44.556	50.924	57.290	63.657
2	2.920	4.303	5.340	6.206	6.965	7.649	8.277	8.861	9.408	9.925
3	2.354	3.183	3.741	4.177	4.541	4.857	5.138	5.392	5.626	5.841
4	2.132	2.777	3.187	3.496	3.747	3.961	4.148	4.315	4.466	4.605
5	2.016	2.571	2.912	3.164	3.365	3.535	3.681	3.811	3.927	4.033
6	1.944	2.447	2.750	2.969	3.143	3.288	3.412	3.522	3.619	3.708
7	1.895	2.365	2.642	2.842	2.998	3.128	3.239	3.336	3.422	3.500
8	1.860	2.307	2.567	2.752	2.897	3.016	3.118	3.206	3.285	3.356
9	1.834	2.263	2.510	2.686	2.822	2.934	3.029	3.111	3.185	3.250
10	1.813	2.229	2.406	2.634	2.764	2.871	2.961	3.039	3.108	3.170
11	1.796	2.301	2.432	2.594	2.719	2.821	2.907	2.981	3.047	3.106
12	1.783	2.179	2.404	2.561	2.681	2.730	2.863	2.935	2.998	3.055
13	1.771	2.161	2.380	2.533	2.651	2.746	2.827	2.897	2.950	3.013
14	1.762	2.145	2.360	2.510	2.625	2.718	2.797	2.864	2.924	2.977
15	1.754	2.132	2.343	2.490	2.603	2.694	2.771	2.837	2.895	2.947
16	1.746	2.120	2.329	2.473	2.584	2.674	2.749	2.814	2.871	2.921
17	1.740	2.110	2.316	2.459	2.567	2.655	2.729	2.793	2.849	2.899
18	1.735	2.101	2.305	2.446	2.553	2.640	2.712	2.775	2.830	2.879
19	1.730	2.094	2.295	2.434	2.540	2.626	2.697	2.759	2.813	2.861
20	1.725	2.086	2.206	2.424	2.528	2.613	2.684	2.745	2.798	2.846
21	1.721	2.080	2.278	2.414	2.518	2.602	2.672	2.732	2.785	2.832
22	1.718	2.074	2.271	2.406	2.509	2.592	2.661	2.721	2.773	2.819
23	1.714	2.069	2.264	2.398	2.500	2.583	2.651	2.710	2.762	2.808
24	1.711	2.064	2.258	2.391	2.493	2.574	2.642	2.701	2.752	2.797
25	1.709	2.060	2.253	2.385	2.486	2.566	2.634	2.692	2.743	2.788
26	1.706	2.056	2.248	2.379	2.479	2.559	2.627	2.684	2.734	2.779
27	1.704	2.052	2.243	2.374	2.473	2.553	2.620	2.677	2.727	2.771
28	1.702	2.049	2.239	2.369	2.468	2.547	2.613	2.670	2.720	2.764

TABLE D.5. CRITICAL VALUES FOR "T" FOR THE T TEST WITH BONFERRONI'S ADJUSTMENT
 P = 0.05 CRITICAL LEVEL, ONE TAILED (CONTINUED)

df	K = 1	K = 2	K = 3	K = 4	K = 5	K = 6	K = 7	K = 8	K = 9	K = 10
29	1.700	2.046	2.235	2.364	2.463	2.541	2.607	2.664	2.713	2.757
30	1.698	2.043	2.231	2.360	2.458	2.536	2.602	2.658	2.707	2.750
31	1.696	2.040	2.228	2.356	2.453	2.531	2.597	2.652	2.701	2.745
32	1.694	2.037	2.224	2.352	2.449	2.527	2.592	2.647	2.696	2.739
33	1.693	2.035	2.221	2.349	2.445	2.523	2.587	2.643	2.691	2.734
34	1.691	2.033	2.219	2.346	2.442	2.519	2.583	2.638	2.686	2.729
35	1.690	2.031	2.216	2.342	2.438	2.515	2.579	2.634	2.682	2.724
36	1.689	2.029	2.213	2.340	2.435	2.512	2.575	2.630	2.678	2.720
37	1.688	2.027	2.211	2.337	2.432	2.508	2.572	2.626	2.674	2.716
38	1.686	2.025	2.209	2.334	2.429	2.505	2.568	2.623	2.670	2.712
39	1.685	2.023	2.207	2.332	2.426	2.502	2.565	2.619	2.667	2.708
40	1.684	2.022	2.205	2.329	2.424	2.499	2.562	2.616	2.663	2.705
50	1.676	2.009	2.189	2.311	2.404	2.478	2.539	2.592	2.638	2.678
60	1.671	2.001	2.179	2.300	2.391	2.463	2.324	2.576	2.621	2.661
70	1.667	1.995	2.171	2.291	2.381	2.453	2.513	2.564	2.609	2.648
80	1.665	1.991	2.166	2.285	2.374	2.446	2.505	2.556	2.600	2.639
90	1.662	1.987	2.162	2.280	2.369	2.440	2.499	2.549	2.593	2.632
100	1.661	1.984	2.158	2.276	2.365	2.435	2.494	2.544	2.588	2.626
110	1.659	1.982	2.156	2.273	2.361	2.432	2.490	2.540	2.583	2.622
120	1.658	1.980	2.153	2.270	2.358	2.429	2.487	2.536	2.580	2.618
Infinite	1.645	1.960	2.129	2.242	2.327	2.394	2.450	2.498	2.540	2.576

d.f. = Degrees of freedom for MSE (Mean Square Error) from ANOVA.

K = Number of concentrations to be compared to the control.

437

20437

APPENDIX E

STEEL'S MANY-ONE RANK TEST

1. Steel's Many-one Rank Test is a nonparametric test for comparing treatments with a control. This test is an alternative to Dunnett's Procedure, and may be applied to data when the normality assumption has not been met. Steel's Test requires equal variances across the treatments and the control, but it is thought to be fairly insensitive to deviations from this condition (Steel, 1959). The tables for Steel's Test require an equal number of replicates at each concentration. If this is not the case, use Wilcoxon's Rank Sum Test, with Bonferroni's adjustment (See Appendix F).

2. For an analysis using Steel's Test, for each control and concentration combination, combine the data and arrange the observations in order of size from smallest to largest. Assign the ranks to the ordered observations (1 to the smallest, 2 to the next smallest, etc.). If ties occur in the ranking, assign the average rank to the observation. (Extensive ties would invalidate this procedure). The sum of the ranks within each concentration and within the control is then calculated. To determine if the response in a concentration is significantly different from the response in the control, the minimum rank sum for each concentration and control combination is compared to the significant values of rank sums given later in the section. In this table, k equals the number of treatments excluding the control and n equals the number of replicates for each concentration and the control.

3. An example of the use of this test is provided below. The test employs survival data from a mysid 7-day, chronic test. The data are listed in Table E.1. Throughout the test, the control data are taken from the site water control. Since there is 0% survival for all eight replicates for the 50% concentration, it is not included in this analysis and is considered a qualitative mortality effect.

4. For each control and concentration combination, combine the data and arrange the observations in order of size from smallest to largest. Assign the ranks (1, 2, 3, ..., 16) to the ordered observations (1 to the smallest, 2 to the next smallest, etc.). If ties occur in the ranking, assign the average rank to each tied observation.

5. An example of assigning ranks to the combined data for the control and 3.12% effluent concentration is given in Table E.2. This ranking procedure is repeated for each control and concentration combination. The complete set of rankings is listed in Table E.3. The ranks are then summed for each effluent concentration, as shown in Table E.4.

6. For this set of data, determine if the survival in any of the effluent concentrations is significantly lower than the survival of the control organisms. If this occurs, the rank sum at that concentration would be significantly lower than the rank sum of the control. Thus, compare the rank sums for the survival at each of the various effluent concentrations with some "minimum" or critical rank sum, at or below which the survival would be considered to be significantly lower than the control. At a probability level

TABLE E.1. EXAMPLE OF STEEL'S MANY-ONE RANK TEST: DATA FOR MYSID, *MYSIDOPSIS BAHIA*, 7-DAY CHRONIC TEST

Effluent Concentration Start of Test	Replicate Chamber at End of Test	Number of Mysids at	Number of Live Mysids
Control (Site Water)	1	5	4
	2	5	4
	3	5	5
	4	5	4
	5	5	5
	6	5	4
	7	5	4
	8	5	5
Control (Brine & Dilution Water)	1	5	3
	2	5	5
	3	5	3
	4	5	3
	5	5	4
	6	5	4
	7	5	3
	8	5	3
3.12%	1	5	4
	2	5	4
	3	5	4
	4	5	5
	5	5	4
	6	5	4
	7	5	5
	8	5	3
6.25%	1	5	3
	2	5	4
	3	5	5
	4	5	4
	5	5	4
	6	5	4
	7	5	5
	8	5	5
12.5%	1	5	5
	2	5	4
	3	5	5
	4	5	3
	5	5	5
	6	5	4
	7	5	4
	8	5	3
25.0%	1	5	5
	2	5	5
	3	5	5
	4	5	5
	5	5	3
	6	5	5
	7	5	4
	8	5	4
50.0%	1	5	0
	2	5	0
	3	5	0
	4	5	0
	5	5	0
	6	5	0
	7	5	0
	8	5	0

TABLE E.2. EXAMPLE OF STEEL'S MANY-ONE RANK TEST: ASSIGNING RANKS TO THE CONTROL AND 3.12% EFFLUENT CONCENTRATIONS

Rank	Number of Live Mysids, <i>Mysidopsis bahia</i>	Control or % Effluent
1	3	3.12
6.5	4	Control
6.5	4	Control
6.5	4	Control
6.5	4	Control
6.5	4	Control
6.5	4	3.12
6.5	4	3.12
6.5	4	3.12
6.5	4	3.12
6.5	4	3.12
14	5	Control
14	5	Control
14	5	Control
14	5	3.12
14	5	3.12

TABLE E.3. TABLE OF RANKS

Replicate Chamber	Control ¹	Effluent Concentration (%)			
		3.12	6.25	12.5	25.0
1	4 (6.5,6,6.5,5)	4 (6.5)	3 (1)	5 (13.5)	5 (12.5)
2	4 (6.5,6,6.5,5)	4 (6.5)	4 (6)	4 (6.5)	5 (12.5)
3	5 (14,13.5,13.5,12.5)	4 (6.5)	5 (13.5)	5 (13.5)	5 (12.5)
4	4 (6.5,6,6.5,5)	5 (14)	4 (6)	3 (1.5)	5 (12.5)
5	5 (14,13.5,13.5,12.5)	4 (6.5)	4 (6)	5 (13.5)	3 (1)
6	4 (6.5,6,6.5,5)	4 (6.5)	4 (6)	4 (6.5)	5 (12.5)
7	4 (6.5,6,6.5,5)	5 (14)	5 (13.5)	4 (6.5)	4 (5)
8	5 (14,13.5,13.5,12.5)	3 (1)	5 (13.5)	3 (1.5)	4 (5)

¹ Control ranks are given in the order of the concentration with which they were ranked.

TABLE E.4. RANK SUMS

Effluent Concentration (%)	Rank Sum
3.12	61.5
6.25	65.5
12.50	63.0
25.00	73.5

of 0.05, the critical rank sum in a test with four concentrations and eight replicates per concentration, is 47 (see Table F.4).

7. Of the rank sums in Table E.4, none are less than 47. Therefore, due to the qualitative effect at the 50% effluent concentration, the NOEC is 25% effluent and the LOEC is 50% effluent.

TABLE E.5. SIGNIFICANT VALUES OF RANK SUMS: JOINT CONFIDENCE COEFFICIENTS OF 0.95 (UPPER) and 0.99 (LOWER) FOR ONE-SIDED ALTERNATIVES (Steel, 1959)

n	k = number of treatments (excluding control)							
	2	3	4	5	6	7	8	9
4	11	10	10	10	10	--	--	--
5	18	17	17	16	16	16	16	15
6	27	26	25	25	24	24	24	23
7	37	36	35	35	34	34	33	33
8	49	48	47	46	46	45	45	44
9	63	62	61	60	59	59	58	58
10	79	77	76	75	74	74	73	72
11	97	95	93	92	91	90	90	89
12	116	114	112	111	110	109	108	108
13	138	135	133	132	130	129	129	128
14	161	158	155	154	153	152	151	150
15	186	182	180	178	177	176	175	174
16	213	209	206	204	203	201	200	199
17	241	237	234	232	231	229	228	227
18	272	267	264	262	260	259	257	256
19	304	299	296	294	292	290	288	287
20	339	333	330	327	325	323	322	320
	315	310	307	305	303	301	300	299

APPENDIX F

WILCOXON RANK SUM TEST

1. Wilcoxon's Rank Sum Test is a nonparametric test, to be used as an alternative to Steel's Many-one Rank Test when the number of replicates are not the same at each concentration. A Bonferroni's adjustment of the pairwise error rate for comparison of each concentration versus the control is used to set an upper bound of alpha on the overall error rate, in contrast to Steel's Many-one Rank Test, for which the overall error rate is fixed at alpha. Thus, Steel's Test is a more powerful test.
2. The use of this test may be illustrated with fecundity data from the mysid test in Table F.1. The site water control and the 12.5% effluent concentration each have seven replicates for the proportion of females bearing eggs, while there are eight replicates for each of the remaining three concentrations.
3. For each concentration and control combination, combine the data and arrange the values in order of size, from smallest to largest. Assign ranks to the ordered observations (a rank of 1 to the smallest, 2 to the next smallest, etc.). If ties in rank occur, assign the average rank to each tied observation.
4. An example of assigning ranks to the combined data for the control and effluent concentration 3.12% is given in Table F.2. This ranking procedure is repeated for each of the three remaining control versus test concentration combinations. The complete set of ranks is listed in Table F.3. The ranks are then summed for each effluent concentration, as shown in Table F.4.
5. For this set of data, determine if the fecundity in any of the test concentrations is significantly lower than the fecundity in the control. If this occurs, the rank sum at that concentration would be significantly lower than the rank sum. Thus, compare the rank sums for fecundity of each of the various effluent concentrations with some "minimum" or critical rank sum, at or below which the fecundity would be considered to be significantly lower than the control. At a probability level of 0.05, the critical rank in a test with four concentrations and seven replicates in the control is 44 for those concentrations with eight replicates, and 34 for those concentrations with seven replicates (see Table F.5, for $K = 4$).
6. Comparing the rank sums in Table F.4 to the appropriate critical rank, only the 25% effluent concentration does not exceed its critical value of 44. Thus, the NOEC and LOEC for fecundity are 12.5% and 25%, respectively.

TABLE F.1. EXAMPLE OF WILCOXON'S RANK SUM TEST: FECUNDITY DATA FOR MYSID, *MYSIDOPSIS BAHIA*, 7-DAY CHRONIC TEST

Effluent Concentration	Replicate Chamber	Number of Mysids at Start of Test	Number of Live Mysids at End of Test	Proportion of Females with Eggs
Control (Site Water)	1	5	4	0.50
	2	5	4	-----
	3	5	5	0.75
	4	5	4	0.67
	5	5	5	0.67
	6	5	4	0.50
	7	5	4	1.00
	8	5	5	1.00
Control (Brine & Dilution Water)	1	5	3	1.00
	2	5	5	1.00
	3	5	3	1.00
	4	5	3	1.00
	5	5	4	1.00
	6	5	4	0.50
	7	5	3	0.50
	8	5	3	0.50
3.12%	1	5	4	1.00
	2	5	4	0.50
	3	5	4	0.67
	4	5	5	1.00
	5	5	4	0.50
	6	5	4	1.00
	7	5	5	1.00
	8	5	3	0.00
6.25%	1	5	3	0.50
	2	5	4	0.00
	3	5	5	0.75
	4	5	4	1.00
	5	5	4	1.00
	6	5	4	1.00
	7	5	5	0.67
	8	5	5	0.67
2.5%	1	5	5	0.33
	2	5	4	0.50
	3	5	5	1.00
	4	5	3	-----
	5	5	5	1.00
	6	5	4	0.00
	7	5	4	0.33
	8	5	3	0.50
25.0%	1	5	5	0.00
	2	5	5	0.50
	3	5	5	0.13
	4	5	5	0.00
	5	5	3	0.50
	6	5	5	0.00
	7	5	4	0.50
	8	5	4	0.50
50.0%	1	5	0	-----
	2	5	0	-----
	3	5	0	-----
	4	5	0	-----
	5	5	0	-----
	6	5	0	-----
	7	5	0	-----
	8	5	0	-----

TABLE F.2. EXAMPLE OF WILCOXON'S RANK SUM TEST: ASSIGNING RANKS TO THE CONTROL AND 3.12% EFFLUENT CONCENTRATIONS

Rank	Proportion of Females W/Eggs	Site Water Control or Effluent %
1	0.00	3.12
3.5	0.50	Control
3.5	0.50	Control
3.5	0.50	3.12
3.5	0.50	3.12
7	0.67	Control
7	0.67	Control
7	0.67	3.12
9	0.75	Control
12.5	1.00	Control
12.5	1.00	Control
12.5	1.00	3.12
12.5	1.00	3.12
12.5	1.00	3.12
12.5	1.00	3.12

TABLE F.3. TABLE OF RANKS¹

Rep	Proportion	Site Water Control Rank	Effluent Concentration (%)			
			3.12	6.25	12.5	25.0
1	0.50	(3.5,3,5.5,7.5)	1.00 (12.5)	0.50 (3)	0.33 (2.5)	0.00 (2)
2		- - - -	0.50 (3.5)	0.00 (1)	0.50 (5.5)	0.50 (7.5)
3	0.75	(9,9.5,10,13)	0.67 (7)	0.75 (9.5)	1.00 (12.5)	0.33 (4)
4	0.67	(7,6.5,8.5,11.5)	1.00 (12.5)	1.00 (13)	--	0.00 (2)
5	0.67	(7,6.5,8.5,11.5)	0.50 (3.5)	1.00 (13)	1.00 (12.5)	0.50 (7.5)
6	0.50	(3.5,3,5.5,7.5)	1.00 (12.5)	1.00 (13)	0.00 (1)	0.00 (2)
7	1.00	(12.5,13,12.5,14.5)	1.00 (12.5)	0.67 (6.5)	0.33 (2.5)	0.50 (7.5)
8	1.00	(12.5,13,12.5,12.5)	0.00 (1)	0.67 (6.5)	0.50 (5.5)	0.50 (7.5)

¹Control ranks are given in the order of the concentration with which they were ranked.

TABLE F.4. RANK SUMS

Effluent Concentration (%)	Rank Sum	No. of Replicates	Critical Rank Sum
3.12	65	8	44
6.25	65.5	8	44
12.50	42	7	34
25.00	40	8	44

TABLE F.5. CRITICAL VALUES FOR WILCOXON'S RANK SUM TEST WITH BONFERRONI'S ADJUSTMENT OF ERROR RATE FOR COMPARISON OF "K" TREATMENTS VERSUS A CONTROL FIVE PERCENT CRITICAL LEVEL (ONE-SIDED ALTERNATIVE: TREATMENT CONTROL)

K	No. Replicates in Control	No. of Replicates Per Effluent Concentration								
		3	4	5	6	7	8	9	10	
1	3	6	10	16	23	30	39	49	59	
	4	6	11	17	24	32	41	51	62	
	5	7	12	19	26	34	44	54	66	
	6	8	13	20	28	36	46	57	69	
	7	8	14	21	29	39	49	60	72	
	8	9	15	23	31	41	51	63	72	
	9	10	16	24	33	43	54	66	79	
	10	10	17	26	35	45	56	69	82	
	2	3	--	--	15	22	29	38	47	58
		4	--	10	16	23	31	40	49	60
5		6	11	17	24	33	42	52	63	
6		7	12	18	26	34	44	55	66	
7		7	13	20	27	36	46	57	69	
8		8	14	21	29	38	49	60	72	
9		8	14	22	31	40	51	62	75	
10		9	15	23	32	42	53	65	78	
3		3	--	--	--	21	29	37	46	57
		4	--	10	16	22	30	39	48	59
	5	--	11	17	24	32	41	51	62	
	6	6	11	18	25	33	43	53	65	
	7	7	12	19	26	35	45	56	68	
	8	7	13	20	28	37	47	58	70	
	9	7	13	21	29	39	49	61	73	
	10	8	14	22	31	41	51	63	76	
	4	3	--	--	--	21	28	37	46	56
		4	--	--	15	22	30	38	48	59
5		--	10	16	23	31	40	50	61	
6		6	11	17	24	33	42	52	64	
7		6	12	18	26	34	44	55	67	
8		7	12	19	27	36	46	57	69	
9		7	13	20	28	38	48	60	72	
10		7	14	21	30	40	50	62	75	

TABLE F.5. CRITICAL VALUES FOR WILCOXON'S RANK SUM TEST WITH BONFERRONI'S ADJUSTMENT OF ERROR RATE FOR COMPARISON OF "K" TREATMENTS VERSUS A CONTROL FIVE PERCENT CRITICAL LEVEL (ONE-SIDED ALTERNATIVE: TREATMENT CONTROL) (CONTINUED)

K	No. Replicates in Control	No. of Replicates Per Effluent Concentration								
		3	4	5	6	7	8	9	10	
5	3	--	--	--	--	28	36	46	56	
	4	--	--	15	22	29	38	48	58	
	5	--	10	16	23	31	40	50	61	
	6	--	11	17	24	32	42	52	63	
	7	6	11	18	25	34	43	54	66	
	8	6	12	19	27	35	45	56	68	
	9	7	13	20	28	37	47	59	71	
	10	7	13	21	29	39	49	61	74	
	6	3	--	--	--	--	28	36	45	56
		4	--	--	15	21	29	38	47	58
5		--	10	16	22	30	39	49	60	
6		--	11	16	24	32	41	51	63	
7		6	11	17	25	33	43	54	65	
8		6	12	18	26	35	45	56	68	
9		6	12	19	27	37	47	58	70	
10		7	13	20	29	38	49	60	73	
7		3	--	--	--	--	--	36	45	56
		4	--	--	--	21	29	37	47	58
	5	--	--	15	22	30	39	49	60	
	6	--	10	16	23	32	41	51	62	
	7	--	11	17	25	33	43	53	65	
	8	6	11	18	26	35	44	55	67	
	9	6	12	19	27	36	46	58	70	
	10	7	13	20	28	38	48	60	72	
	8	3	--	--	--	--	--	36	45	55
		4	--	--	--	21	29	37	47	57
5		--	--	15	22	30	39	49	59	
6		--	10	16	23	31	40	51	62	
7		--	11	17	24	33	42	53	64	
8		6	11	18	25	34	44	55	67	
9		6	12	19	27	36	46	57	69	
10		6	12	19	28	37	48	59	72	

TABLE F.5. CRITICAL VALUES FOR WILCOXON'S RANK SUM TEST WITH BONFERRONI'S ADJUSTMENT OF ERROR RATE FOR COMPARISON OF "K" TREATMENTS VERSUS A CONTROL FIVE PERCENT CRITICAL LEVEL (ONE-SIDED ALTERNATIVE: TREATMENT CONTROL) (CONTINUED)

K	No. Replicates in Control	No. of Replicates Per Effluent Concentration							
		3	4	5	6	7	8	9	10
9	3	--	--	--	--	--	--	45	55
	4	--	--	--	21	28	37	46	57
	5	--	--	15	22	30	39	48	59
	6	--	10	16	23	31	40	50	62
	7	--	10	17	24	33	42	52	64
	8	--	11	18	25	34	44	55	66
	9	6	11	18	26	35	46	57	69
	10	6	12	19	28	37	47	59	71
10	3	--	--	--	--	--	--	45	55
	4	--	--	--	21	28	37	46	57
	5	--	--	15	22	29	38	48	59
	6	--	10	16	23	31	40	50	61
	7	--	10	16	24	32	42	52	64
	8	--	11	17	25	34	43	54	66
	9	6	11	18	26	35	45	56	68
	10	6	12	19	27	37	47	58	71

APPENDIX G

SINGLE CONCENTRATION TOXICITY TEST - COMPARISON OF CONTROL WITH 100% EFFLUENT OR RECEIVING WATER

1. To statistically compare a control with one concentration, such as 100% effluent or the instream waste concentration, a t test is the recommended analysis. The t test is based on the assumptions that the observations are independent and normally distributed and that the variances of the observations are equal between the two groups.

2. Shapiro-Wilk's test may be used to test the normality assumption (See Appendix B for details). If the data do not meet the normality assumption, the nonparametric test, Wilcoxon's Rank Sum Test, may be used to analyze the data. An example of this test is given in Appendix F. Since a control and one concentration are being compared, the K = 1 section of Table F.5 contains the needed critical values.

3. The F test for equality of variances is used to test the homogeneity of variance assumption. When conducting the F test, the alternative hypothesis of interest is that the variances are not equal.

4. To make the two-tailed F test at the 0.01 level of significance, put the larger of the two variances in the numerator of F.

$$F = \frac{S_1^2}{S_2^2} \quad \text{where } S_1^2 > S_2^2$$

5. Compare F with the 0.005 level of a tabled F value with $n_1 - 1$ and $n_2 - 1$ degrees of freedom, where n_1 and n_2 are the number of replicates for each of the two groups.

6. A set of mysid growth data from an effluent (single concentration) test will be used to illustrate the F test. The raw data, mean and variance for the control and 100% effluent are given in Table G.1.

7. Since the variability of the 100% effluent is greater than the variability of the control, S^2 for the 100% effluent concentration is placed in the numerator of the F statistic and S^2 for the control is placed in the denominator.

$$F = \frac{0.00131}{0.000861} = 1.52$$

8. There are 8 replicates for the effluent concentration and 8 replicates for the control. Thus, both numerator and denominator degrees of freedom are equal to 7. For a two-tailed test at the 0.01 level of significance, the

TABLE G.1. MYSID, *MYSIDOPSIS BAHIA*, GROWTH DATA FROM AN EFFLUENT (SINGLE CONCENTRATION) TEST

	Replicate								\bar{X}	S^2
	1	2	3	4	5	6	7	8		
Control	0.183	0.148	0.216	0.199	0.176	0.243	0.213	0.180	0.195	0.000861
100% Effluent	0.153	0.117	0.085	0.153	0.086	0.193	0.137	0.129	0.132	0.00131

critical F value is obtained from a table of the F distribution (Snedecor and Cochran, 1980). The critical F value for this test is 8.89. Since 1.52 is not greater than 8.89, the conclusion is that the variances of the control and 100% effluent are homogeneous.

9. Equal Variance T Test.

9.1 To perform the t test, calculate the following test statistic:

$$t = \frac{\bar{Y}_1 - \bar{Y}_2}{S_p \sqrt{\frac{1}{n_1} + \frac{1}{n_2}}}$$

Where: \bar{Y}_1 = mean for the control

\bar{Y}_2 = mean for the effluent concentration

$$S_p = \frac{\sqrt{(n_1 - 1)S_1^2 + (n_2 - 1)S_2^2}}{n_1 + n_2 - 2}$$

S_1^2 = estimate of the variance for the control

S_2^2 = estimate of the variance for the effluent concentration

n_1 = number of replicates for the control

n_2 = number of replicates for the effluent concentration

9.2 Since we are usually concerned with a decreased response from the control, such as a decrease in survival or a decrease in reproduction, a one-tailed test is appropriate. Thus, you would compare the calculated t with a critical t , where the critical t is at the 5% level of significance with $n_1 + n_2 - 2$ degrees of freedom. If the calculated t exceeds the critical t , the mean responses are declared different.

9.3 Using the data from Table G.1 to illustrate the t test, the calculation of t is as follows:

$$t = \frac{0.195 - 0.132}{0.0329 \sqrt{\frac{1}{8} + \frac{1}{8}}} = 3.83$$

Where:

$$S_p = \frac{\sqrt{(8-1)0.000861 + (8-1)0.00131}}{8+8-2} = 0.0329$$

9.4 For an 0.05 level of significance test with 14 degrees of freedom, the critical t is 1.762 (Note: Table D.5 for $K = 1$ includes the critical t values for comparing two groups). Since 3.83 is greater than 1.762, the conclusion is that the growth for the 100% effluent concentration is significantly lower than growth for the control.

10. UNEQUAL VARIANCE T TEST.

10.1 If the F test for equality of variance fails, the t test is still a valid test. However, the denominator of the t statistic is adjusted as follows:

$$t = \frac{\bar{Y}_1 - \bar{Y}_2}{\sqrt{\frac{S_1^2}{n_1} + \frac{S_2^2}{n_2}}}$$

- Where:
- \bar{Y}_1 = mean for the control
 - \bar{Y}_2 = mean for the effluent concentration
 - S_1^2 = estimate of the variance for the control
 - S_2^2 = estimate of the variance for the effluent concentration
 - n_1 = number of replicates for the control
 - n_2 = number of replicates for the effluent concentration

10.2 Additionally, the degrees of freedom for the test are adjusted using the following formula:

$$df' = \frac{(n_1 - 1)(n_2 - 1)}{(n_2 - 1)C^2 + (1 - C)^2(n_1 - 1)}$$

Where:

$$C = \frac{\frac{S_1^2}{n_1}}{\frac{S_1^2}{n_1} + \frac{S_2^2}{n_2}}$$

10.3 The modified degrees of freedom is usually not an integer. Common practice is to round down to the nearest integer.

10.4 The t test is then conducted as the equal variance t test. The calculated t is compared to the critical t at the 0.05 significance level with the modified degrees of freedom. If the calculated t exceeds the critical t, the mean responses are found to be statistically different.

APPENDIX H

PROBIT ANALYSIS

1. This program calculates the EC1 and EC50 (or LC1 and LC50), and the associated 95% confidence intervals.

2. The program is written in IBM PC Basic for the IBM compatible PC by Computer Sciences Corporation, 26 W. Martin Luther King Drive, Cincinnati, OH 45268. A compiled, executable version of the program and supporting documentation can be obtained from EMSL-Cincinnati by sending a written request to EMSL at 3411 Church Street, Cincinnati, OH 45244.

2.1 Data input is illustrated by a set of mortality data (Figure H.1) from a sheepshead minnow embryo-larval survival and teratogenicity test. The program begins with a request for the following information:

1. Desired output of abbreviated (A) or full (F) output? (Note: only abbreviated output is shown below.)
2. Output designation (P = printer, D = disk file).
3. Title for the output.
4. The number of exposure concentrations.
5. Toxicant concentration data.

2.2 The program output for the abbreviated output includes the following:

1. A table of the observed proportion responding and the proportion responding adjusted for the controls (see Figure H.2)
2. The calculated chi-square statistic for heterogeneity and the tabular value. This test is one indicator of how well the data fit the model. The program will issue a warning when the test indicates that the data do not fit the model.
3. The estimated LC1 and LC50 values and associated 95% confidence intervals (see Table H.2).

EPA PROBIT ANALYSIS PROGRAM
USED FOR CALCULATING LC/EC VALUES
Version 1.5

Do you wish abbreviated (A) or full (F) input/output? A
 Output to printer (P) or disk file (D)? P
 Title ? Example of Probit Analysis

Number responding in the control group = ? 17
 Number of animals exposed in the concurrent control group = ? 100
 Number of exposure concentrations, exclusive of controls ? 5

Input data starting with the lowest exposure concentration

Concentration = ? 6.25
 Number responding = ? 14
 Number exposed = ? 100

Concentration = ? 12.5
 Number responding = ? 16
 Number exposed = ? 102

Concentration = ? 25.0
 Number responding = ? 35
 Number exposed = ? 100

Concentration = ? 50.0
 Number responding = ? 72
 Number exposed = ? 99

Concentration = ? 100
 Number responding = ? 99
 Number exposed = ? 99

Number	Conc.	Number Resp.	Number Exposed
1	6.2500	14	100
2	12.5000	16	102
3	25.0000	35	100
4	50.0000	72	99
5	100.0000	99	99

Do you wish to modify your data ? N

The number of control animals which responded = 17
 The number of control animals exposed = 100
 Do you wish to modify these values ? N

Figure H.1. Sample Data Input for USEPA Probit Analysis Program, Version 1.5.

Example of Probit Analysis

Conc.	Number Exposed	Number Resp.	Observed Proportion Responding	Proportion Responding Adjusted for Controls
Control	100	17	0.1700	0.0000
6.2500	100	14	0.1400	0.0201
12.5000	102	16	0.1569	0.0001
25.0000	100	35	0.3500	0.2290
50.0000	99	72	0.7273	0.6765
100.0000	99	99	1.0000	1.0000

Chi - Square for Heterogeneity (calculated) = 3.472
 Chi - Square for Heterogeneity (tabular value at 0.05 level) = 7.815

Example of Probit Analysis

Estimated LC/EC Values and Confidence Limits

Point	Exposure Conc.	Lower 95% Confidence	Upper Limits
LC/EC 1.00	12.917	8.388	16.888
LC/EC 50.00	37.667	32.898	42.081

Figure H.2. USEPA Probit Analysis Program used for Calculating LC/EC Values, Version 1.5.

APPENDIX I

SPEARMAN-KARBER METHOD

1. The Spearman-Karber Method is a nonparametric statistical procedure for estimating the LC50 and the associated 95% confidence interval (Finney, 1978). The Spearman-Karber Method estimates the mean of the distribution of the \log_{10} of the tolerance. If the log tolerance distribution is symmetric, this estimate of the mean is equivalent to an estimate of the median of the log tolerance distribution.
2. If the response proportions are not monotonically non-decreasing with increasing concentration (constant or steadily increasing with concentration), the data must be smoothed. Abbott's procedure is used to "adjust" the concentration response proportions for mortality occurring in the control replicates.
3. Use of the Spearman-Karber Method is recommended when partial mortalities occur in the test solutions, but the data do not fit the Probit model.
4. To calculate the LC50 using the Spearman-Karber Method, the following must be true: 1) the smoothed adjusted proportion mortality for the lowest effluent concentration (not including the control) must be zero, and 2) the smoothed adjusted proportion mortality for the highest effluent concentration must be one.
5. To calculate the 95% confidence interval for the LC50 estimate, one or more of the smoothed adjusted proportion mortalities must be between zero and one.
6. The Spearman-Karber Method is illustrated below using a set of mortality data from a Sheepshead Minnow Larval Survival and Growth test. These data are listed in Table I.1.
7. Let p_0, p_1, \dots, p_k denote the observed response proportion mortalities for the control and k effluent concentrations. The first step is to smooth the p_i if they do not satisfy $p_0 \leq p_1 \leq \dots \leq p_k$. The smoothing process replaces any adjacent p_i 's that do not conform to $p_0 \leq p_1 \leq \dots \leq p_k$ with their average. For example, if p_i is less than p_{i-1} then:

$$p_{i-1}^s = p_i^s = (p_i + p_{i-1}) / 2$$

Where: p_i^s = the smoothed observed proportion mortality for effluent concentration i .

7.1 For the data in this example, because the observed mortality proportions for the control and the 6.25% effluent concentration are greater than the observed response proportions for the 12.5% and 25.0% effluent concentrations, the responses for these four groups must be averaged:

$$p_0^s = p_1^s = p_2^s = \frac{0.05 + 0.05 + 0.00 + 0.00}{4} = \frac{0.10}{4} = 0.025$$

TABLE I.1. EXAMPLE OF SPEARMAN-KARBER METHOD: MORTALITY DATA FROM A SHEEPSHEAD MINNOW LARVAL SURVIVAL AND GROWTH TEST (40 ORGANISMS PER CONCENTRATION)

Effluent Concentration %	Number of Mortalities	Mortality Proportion
Control	2	0.05
6.25	2	0.05
12.5	0	0.00
25.0	0	0.00
50.0	26	0.65
100.0	40	1.00

7.2 Since $p_4^s = 0.65$ is larger than p_3^s , set $p_4^s = 0.65$. Similarly, $p_5 = 1.00$ is larger than p_4^s , so set $p_5^s = 1.00$. Additional smoothing is not necessary. The smoothed observed proportion mortalities are shown in Table I.2.

TABLE I.2. EXAMPLE OF SPEARMAN-KARBER METHOD: SMOOTHED, ADJUSTED MORTALITY DATA FROM A SHEEPSHEAD MINNOW LARVAL SURVIVAL AND GROWTH TEST

Effluent Concentration %	Mortality Proportion	Smoothed Mortality Proportion	Smoothed, Adjusted Mortality Proportion
Control	0.05	0.025	0.000
6.25	0.05	0.025	0.000
12.5	0.00	0.025	0.000
25.0	0.00	0.025	0.000
50.0	0.65	0.650	0.641
100.0	1.00	1.000	1.000

8. Adjust the smoothed observed proportion mortality in each effluent concentration for mortality in the control group using Abbott's formula (Finney, 1971). The adjustment takes the form:

Where: $p_i^a = (p_i^s - p_0^s) / (1 - p_0^s)$

p_0^s = the smoothed observed proportion mortality for the control

p_i^s = the smoothed observed proportion mortality for effluent concentration i .

8.1 For the data in this example, the data for each effluent concentration must be adjusted for control mortality using Abbott's formula, as follows:

$$p_0^a = p_1^a = p_2^a = p_3^a = \frac{p_1^s - p_0^s}{1 - p_0^s} = \frac{0.025 - 0.025}{1 - 0.025} = \frac{0.0}{0.975} = 0.0$$

$$p_4^a = \frac{p_4^s - p_0^s}{1 - p_0^s} = \frac{0.650 - 0.025}{1 - 0.025} = \frac{0.0625}{0.975} = 0.641$$

$$p_5^a = \frac{p_5^s - p_0^s}{1 - p_0^s} = \frac{1.000 - 0.025}{1 - 0.025} = \frac{0.975}{0.975} = 1.000$$

The smoothed, adjusted response proportions for the effluent concentrations are shown in Table I.2. A plot of the smoothed, adjusted data is shown in Figure I.1.

9. Calculate the \log_{10} of the estimated LC50, m , as follows:

$$m = \sum_{i=1}^{k-1} \frac{(p_{i+1}^a)(X_i + X_{i+1})}{2}$$

Where: p_i^a = the smoothed adjusted proportion mortality at concentration i

X_i = the \log_{10} of concentration i

k = the number of effluent concentrations tested, not including the control.

9.1 For this example, the \log_{10} of the estimated LC50, m , is calculated as follows:

$$\begin{aligned} m &= [(0.000 - 0.000)(0.7959 + 1.0969)]/2 + \\ & \quad [(0.000 - 0.000)(1.0969 + 1.3979)]/2 + \\ & \quad [(0.641 - 0.000)(1.3979 + 1.6990)]/2 + \\ & \quad [(1.000 - 0.641)(1.6990 + 2.0000)]/2 \\ &= 1.656527 \end{aligned}$$

460

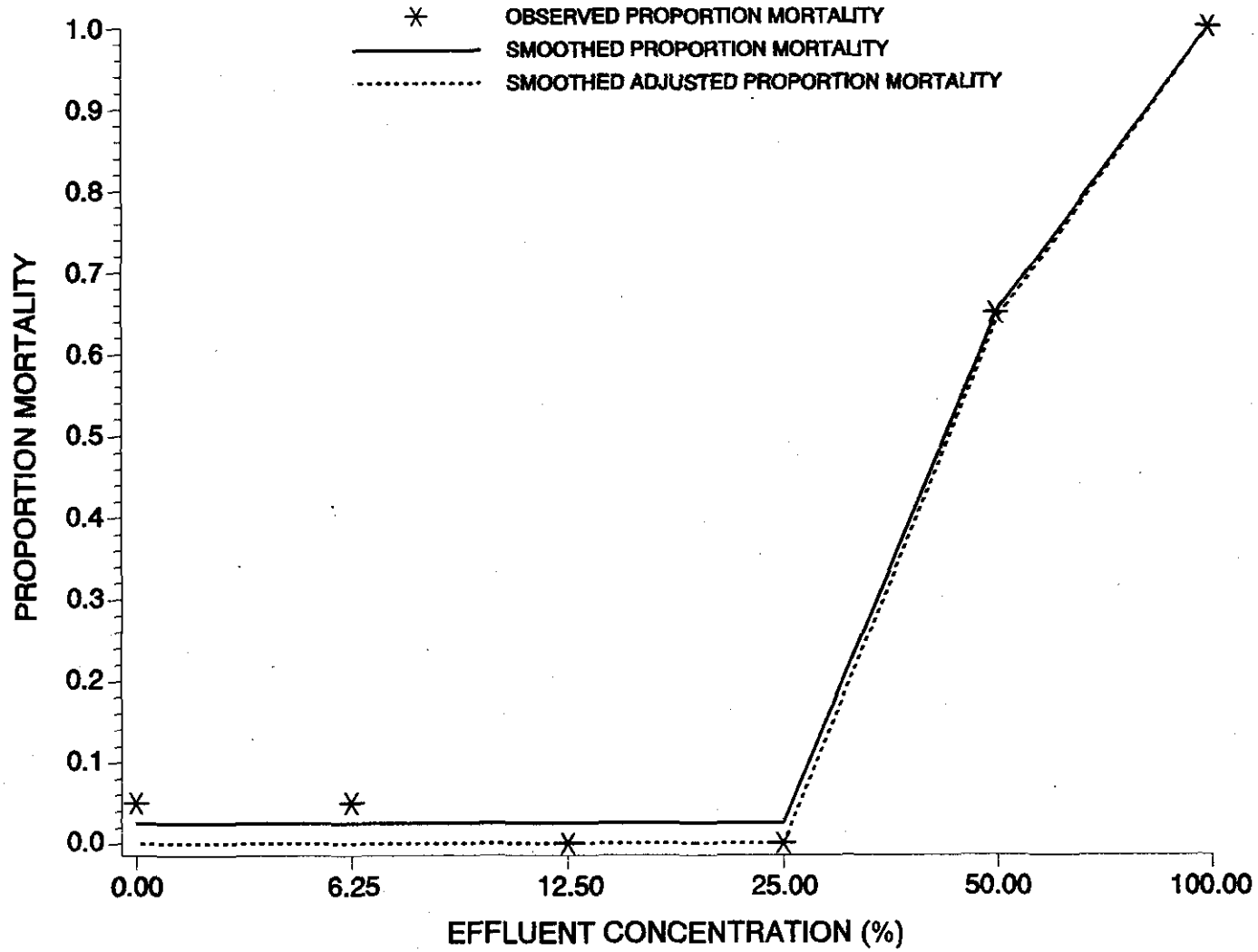

Figure I.1. Plot of observed, smoothed, and adjusted response proportions for sheephead minnow, *Cyprinodon variegatus*, survival data.

20460

10. Calculate the estimated variance of m as follows:

$$V(m) = \sum_{i=2}^{k-1} \frac{p_i^a (1-p_i^a) (X_{i+1} + X_{i-1})^2}{4(n_i-1)}$$

Where: X_i = the \log_{10} of concentration i

n_i = the number of organisms tested at effluent concentration i

p_i^a = the smoothed adjusted observed proportion mortality at effluent concentration i

k = the number of effluent concentrations tested, not including the control.

10.1 For this example, the estimated variance of m , $V(m)$, is calculated as follows:

$$\begin{aligned} V(m) &= (0.000)(1.000)(1.3979 - 0.7959)^2/4(39) + \\ &\quad (0.000)(1.000)(1.6990 - 1.0969)^2/4(39) + \\ &\quad (0.641)(0.359)(2.0000 - 1.3979)^2/4(39) \\ &= 0.00053477 \end{aligned}$$

11. Calculate the 95% confidence interval for m : $m \pm 2.0 \sqrt{V(m)}$

11.1 For this example, the 95% confidence interval for m is calculated as follows:

$$1.656527 \pm 2\sqrt{0.00053477} = (1.610277, 1.702777)$$

12. The estimated LC50 and a 95% confidence interval for the estimated LC50 can be found by taking base₁₀ antilogs of the above values.

12.1 For this example, the estimated LC50 is calculated as follows:

$$\text{LC50} = \text{antilog}(m) = \text{antilog}(1.656527) = 45.3\%$$

12.2 The limits of the 95% confidence interval for the estimated LC50 are calculated by taking the antilogs of the upper and lower limits of the 95% confidence interval for m as follows:

$$\text{lower limit: } \text{antilog}(1.610277) = 40.8\%$$

$$\text{upper limit: } \text{antilog}(1.702777) = 50.4\%$$

APPENDIX J

TRIMMED SPEARMAN-KARBER METHOD

1. The Trimmed Spearman-Karber Method is a modification of the Spearman-Karber Method, a nonparametric statistical procedure for estimating the LC50 and the associated 95% confidence interval (Hamilton, et al, 1977). The Trimmed Spearman-Karber Method estimates the trimmed mean of the distribution of the \log_{10} of the tolerance. If the log tolerance distribution is symmetric, this estimate of the trimmed mean is equivalent to an estimate of the median of the log tolerance distribution.
2. If the response proportions are not monotonically non-decreasing with increasing concentration (constant or steadily increasing with concentration), the data must be smoothed. Abbott's procedure is used to "adjust" the concentration response proportions for mortality occurring in the control replicates.
3. Use of the Trimmed Spearman-Karber Method is recommended only when the requirements for the Probit Analysis and the Spearman-Karber Method are not met.
4. To calculate the LC50 using the Trimmed Spearman-Karber Method, the smoothed, adjusted, observed proportion mortalities must bracket 0.5.
5. To calculate the 95% confidence interval for the LC50 estimate, one or more of the smoothed, adjusted, observed proportion mortalities must be between zero and one.
6. Let p_0, p_1, \dots, p_k denote the observed proportion mortalities for the control and the k effluent concentrations. The first step is to smooth the p_i if they do not satisfy $p_0 \leq p_1 \leq \dots \leq p_k$. The smoothing process replaces any adjacent p_i 's that do not conform to $p_0 \leq p_1 \leq \dots \leq p_k$, with their average. For example, if p_i is less than p_{i-1} then:

Where: $p_{i-1}^s = p_i^s = (p_i + p_{i-1})/2$

p_i^s = the smoothed observed proportion mortality for effluent concentration i .

7. Adjust the smoothed observed proportion mortality in each effluent concentration for mortality in the control group using Abbott's formula (Finney, 1971). The adjustment takes the form:

Where: $p_i^a = (p_i^s - p_0^s) / (1 - p_0^s)$

p_0^s = the smoothed observed proportion mortality for the control

p_i^s = the smoothed observed proportion mortality for effluent concentration i .

8. Calculate the amount of trim to use in the estimation of the LC50 as follows:

Where: $\text{Trim} = \max(p_1^a, 1-p_k^a)$

p_1^a = the smoothed, adjusted proportion mortality for the lowest effluent concentration, exclusive of the control

p_k^a = the smoothed, adjusted proportion mortality for the highest effluent concentration

k = the number of effluent concentrations, exclusive of the control.

The minimum trim should be calculated for each data set rather than using a fixed amount of trim for each data set.

9. Due to the intensive nature of the calculation for the estimated LC50 and the calculation of the associated 95% confidence interval using the Trimmed Spearman-Karber Method, it is recommended that the data be analyzed by computer.

10. A computer program which estimates the LC50 and associated 95% confidence interval using the Trimmed Spearman-Karber Method, can be obtained through the EMSL, 3411 Church Street, Cincinnati, OH 45244. The program can be obtained from EMSL-Cincinnati by sending a written request to the above address.

11. The Trimmed Spearman-Karber program automatically performs the following functions:

- a. Smoothing.
- b. Adjustment for mortality in the control.
- c. Calculation of the necessary trim.
- d. Calculation of the LC50.
- e. Calculation of the associated 95% confidence interval.

12. To illustrate the Trimmed Spearman-Karber method using the Trimmed Spearman-Karber computer program, a set of data from a Sheepshead Minnow Larval Survival and Growth test will be used. The data are listed in Table J.1.

12.1 The program requests the following input (Figure J.1):

- a. Output destination (D = disk file or P = printer).
- b. Control data.
- c. Data for each toxicant concentration.

12.2 The program output includes the following (Figure J.2):

- a. A table of the concentrations tested, number of organisms exposed, and the mortalities.
- b. The amount of trim used in the calculation.
- c. The estimated LC50 and the associated 95% confidence interval.

TABLE J.1. EXAMPLE OF TRIMMED SPEARMAN-KARBER METHOD: MORTALITY DATA FROM A SHEEPSHEAD MINNOW LARVAL SURVIVAL AND GROWTH TEST (40 ORGANISMS PER CONCENTRATION)

Effluent Concentration %	Number of Mortalities	Mortality Proportion
Control	2	0.05
6.25	0	0.00
12.5	2	0.05
25.0	0	0.00
50.0	0	0.00
100.0	32	0.80

A:>TSK

TRIMMED SPEARMAN-KARBER METHOD. VERSION 1.5

ENTER DATE OF TEST:

1

ENTER TEST NUMBER:

2

WHAT IS TO BE ESTIMATED?

(ENTER "L" FOR LC50 AND "E" FOR EC50)

L

ENTER TEST SPECIES NAME:

Sheepshead minnow

ENTER TOXICANT NAME:

effluent

ENTER UNITS FOR EXPOSURE CONCENTRATION OF TOXICANT :

%

ENTER THE NUMBER OF INDIVIDUALS IN THE CONTROL:

40

ENTER THE NUMBER OF MORTALITIES IN THE CONTROL:

2

ENTER THE NUMBER OF CONCENTRATIONS

(NOT INCLUDING THE CONTROL; MAX = 10):

5

ENTER THE 5 EXPOSURE CONCENTRATIONS (IN INCREASING ORDER):

6.25 12.5 25 50 100

ARE THE NUMBER OF INDIVIDUALS AT EACH EXPOSURE CONCENTRATION EQUAL(Y/N)?

y

ENTER THE NUMBER OF INDIVIDUALS AT EACH EXPOSURE CONCENTRATION:

40

ENTER UNITS FOR DURATION OF EXPERIMENT

(ENTER "H" FOR HOURS, "D" FOR DAYS, ETC.):

Days

ENTER DURATION OF TEST:

7

ENTER THE NUMBER OF MORTALITIES AT EACH EXPOSURE CONCENTRATION:

0 2 0 0 32

WOULD YOU LIKE THE AUTOMATIC TRIM CALCULATION(Y/N)?

y

Figure J.1. Example input for Trimmed Spearman-Karber Method.

TRIMMED SPEARMAN-KARBER METHOD. VERSION 1.5

DATE: 1 TEST NUMBER: 2 DURATION: 7 Days
TOXICANT: effluent
SPECIES: sheepshead minnow

RAW DATA:	Concentration	Number	Mortalities
-----	(%)	Exposed	
	.00	40	2
	6.25	40	0
	12.50	40	2
	25.00	40	0
	50.00	40	0
	100.00	40	32

SPEARMAN-KARBER TRIM: 20.41%

SPEARMAN-KARBER ESTIMATES: LC50: 77.28
95% CONFIDENCE LIMITS
ARE NOT RELIABLE.

NOTE: MORTALITY PROPORTIONS WERE NOT MONOTONICALLY INCREASING.
ADJUSTMENTS WERE MADE PRIOR TO SPEARMAN-KARBER ESTIMATION.

Figure J.2. Example output for Trimmed Spearman-Karber Method.

APPENDIX K
GRAPHICAL METHOD

1. The Graphical Method is used to calculate the LC50. It is a mathematical procedure which estimates the LC50 by linearly interpolating between points of a plot of observed percent mortality versus the base 10 logarithm (\log_{10}) of percent effluent concentration. This method does not provide a confidence interval for the LC50 estimate and its use is only recommended when there are no partial mortalities. The only requirement for the Graphical Method is that the observed percent mortalities bracket 50%.
2. For an analysis using the Graphical Method the data must first be smoothed and adjusted for mortality in the control replicates. The procedure for smoothing and adjusting the data is detailed in the following steps.
3. The Graphical Method is illustrated below using a set of mortality data from an Inland Silverside Larval Survival and Growth test. These data are listed in Table K.1.

TABLE K.1. EXAMPLE OF GRAPHICAL METHOD: MORTALITY DATA FROM AN INLAND SILVERSIDE LARVAL SURVIVAL AND GROWTH TEST (40 ORGANISMS PER CONCENTRATION)

Effluent Concentration %	Number of Mortalities	Mortality Proportion
Control	2	0.05
6.25	0	0.00
12.5	0	0.00
25.0	0	0.00
50.0	40	1.00
100.0	40	1.00

4. Let p_0, p_1, \dots, p_k denote the observed proportion mortalities for the control and the k effluent concentrations. The first step is to smooth the p_i if they do not satisfy $p_0 \leq p_1 \leq \dots \leq p_k$. The smoothing process replaces any adjacent p_i 's that do not conform to $p_0 \leq p_1 \leq \dots \leq p_k$ with their average. For example, if p_i is less than p_{i-1} then:

Where:

$$p_{i-1}^s = p_i^s = (p_i + p_{i-1}) / 2$$

p_i^s = the smoothed observed proportion mortality for effluent concentration i .

4.1 For the data in this example, because the observed mortality proportions for the 6.25%, 12.5%, and 25.0% effluent concentrations are less than the observed response proportion for the control, the values for these four groups must be averaged:

$$p_0^s = p_1^s = p_2^s = p_3^s = \frac{0.05+0.00+0.00+0.00}{4} = \frac{0.05}{4} = 0.0125$$

4.2 Since $p_4 = p_5 = 1.00$ are larger than 0.0125, set $p_4^s = p_5^s = 1.00$. Additional smoothing is not necessary. The smoothed observed proportion mortalities are shown in Table K.2.

5. Adjust the smoothed observed proportion mortality in each effluent concentration for mortality in the control group using Abbott's formula (Finney, 1971). The adjustment takes the form:

Where:

$$p_i^a = (p_i^s - p_0^s) / (1 - p_0^s)$$

p_0^s = the smoothed observed proportion mortality for the control

p_i^s = the smoothed observed proportion mortality for effluent concentration i .

5.1 Because the smoothed observed proportion mortality for the control group is greater than zero, the responses must be adjusted using Abbott's formula, as follows:

$$p_0^a = p_1^a = p_2^a = p_3^a = \frac{p_1^s - p_0^s}{1 - p_0^s} = \frac{0.0125 - 0.0125}{1 - 0.0125} = \frac{0.0}{0.9875} = 0.0$$

$$p_4^a = p_5^a = \frac{p_4^s - p_0^s}{1 - p_0^s} = \frac{1.00 - 0.0125}{1 - 0.0125} = \frac{0.9875}{0.9875} = 1.00$$

A table of the smoothed, adjusted response proportions for the effluent concentrations are shown in Table K.2.

5.2 Plot the smoothed, adjusted data on 2-cycle semi-log graph paper with the logarithmic axis (the y axis) used for percent effluent concentration and the linear axis (the x axis) used for observed percent mortality. A plot of the smoothed, adjusted data is shown in Figure K.1.

TABLE K.2. EXAMPLE OF GRAPHICAL METHOD: SMOOTHED, ADJUSTED MORTALITY DATA FROM AN INLAND SILVERSIDE LARVAL SURVIVAL AND GROWTH TEST

Effluent Concentration %	Mortality Proportion	Smoothed Mortality Proportion	Smoothed, Adjusted Mortality Proportion
Control	0.05	0.0125	0.00
6.25	0.00	0.0125	0.00
12.5	0.00	0.0125	0.00
25.0	0.00	0.0125	0.00
50.0	1.00	1.0000	1.00
100.0	1.00	1.0000	1.00

6. Locate the two points on the graph which bracket 50% mortality and connect them with a straight line.

7. On the scale for percent effluent concentration, read the value for the point where the plotted line and the 50% mortality line intersect. This value is the estimated LC50 expressed as a percent effluent concentration.

7.1 For this example, the two points on the graph which bracket the 50% mortality line (0% mortality at 25% effluent, and 100% mortality at 50% effluent) are connected with a straight line. The point at which the plotted line intersects the 50% mortality line is the estimated LC50. The estimated LC50 = 35% effluent.

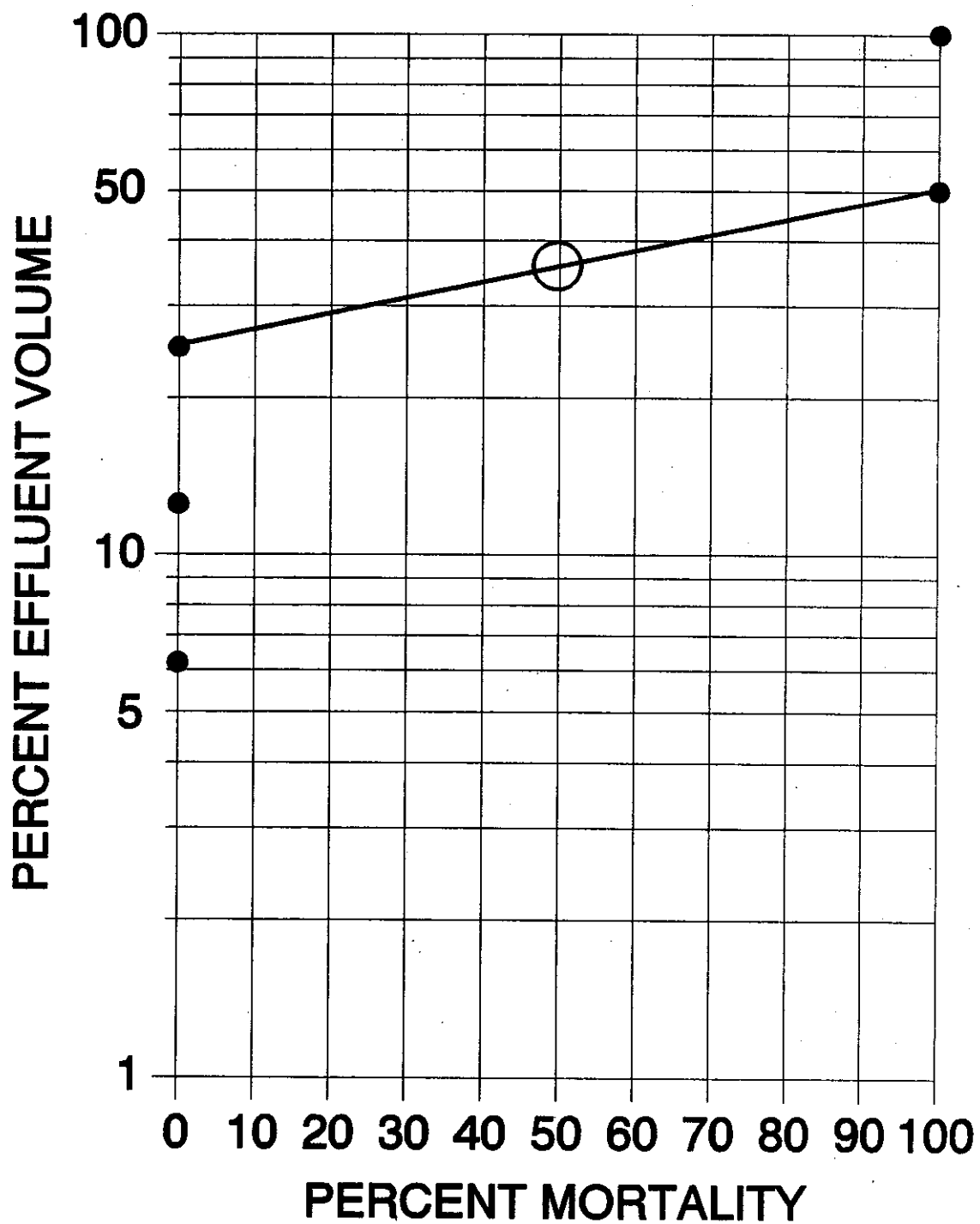

Figure K.1. Plot of the smoothed adjusted response proportions for inland silverside, *Menidia beryllina*, survival data.

APPENDIX L

LINEAR INTERPOLATION METHOD

1. GENERAL PROCEDURE

1.1 The Linear Interpolation Method is used to calculate a point estimate of the effluent or other toxicant concentration that causes a given percent reduction (e.g., 25%, 50%, etc.) in the reproduction or growth of the test organisms (Inhibition Concentration, or IC). The procedure was designed for general applicability in the analysis of data from short-term chronic toxicity tests, and the generation of an endpoint from a continuous model that allows a traditional quantitative assessment of the precision of the endpoint, such as confidence limits for the endpoint of a single test, and a mean and coefficient of variation for the endpoints of multiple tests.

1.2 The Linear Interpolation Method assumes that the responses (1) are monotonically non-increasing, where the mean response for each higher concentration is less than or equal to the mean response for the previous concentration, (2) follow a piecewise linear response function, and (3) are from a random, independent, and representative sample of test data. If the data are not monotonically non-increasing, they are adjusted by smoothing (averaging). In cases where the responses at the low toxicant concentrations are much higher than in the controls, the smoothing process may result in a large upward adjustment in the control mean. Also, no assumption is made about the distribution of the data except that the data within a group being resampled are independent and identically distributed.

2. DATA SUMMARY AND PLOTS

2.1 Calculate the mean responses for the control and each toxicant concentration, construct a summary table, and plot the data.

3. MONOTONICITY

3.1 If the assumption of monotonicity of test results is met, the observed response means (Y_i) should stay the same or decrease as the toxicant concentration increases. If the means do not decrease monotonically, the responses are "smoothed" by averaging (pooling) adjacent means.

3.2 Observed means at each concentration are considered in order of increasing concentration, starting with the control mean (Y_1). If the mean observed response at the lowest toxicant concentration (Y_2) is equal to or smaller than the control mean (Y_1), it is used as the response. If it is larger than the control mean, it is averaged with the control, and this average is used for both the control response (M_1) and the lowest toxicant concentration response (M_2). This mean is then compared to the mean observed response for the next higher toxicant concentration (Y_3). Again, if the mean observed response for the next higher toxicant concentration is smaller than the mean of the control and the lowest toxicant concentration, it is used as the response. If it is higher than the mean of the first two, it is averaged with the first two, and the mean is used as the response for the control and

two lowest concentrations of toxicant. This process is continued for data from the remaining toxicant concentrations. A numerical example of smoothing the data is provided below. (Note: Unusual patterns in the deviations from monotonicity may require an additional step of smoothing). Where \bar{Y}_i decrease monotonically, the \bar{Y}_i become M_i without smoothing.

4. LINEAR INTERPOLATION METHOD

4.1 The method assumes a linear response from one concentration to the next. Thus, the IC_p is estimated by linear interpolation between two concentrations whose responses bracket the response of interest, the (p) percent reduction from the control.

4.2 To obtain the estimate, determine the concentrations C_J and C_{J+1} which bracket the response $M_1 (1 - p/100)$, where M_1 is the smoothed control mean response and p is the percent reduction in response relative to the control response. These calculations can easily be done by hand or with a computer program as described below. The linear interpolation estimate is calculated as follows:

$$IC_p = C_J + [M_1 (1 - p/100) - M_J] \frac{(C_{J+1} - C_J)}{(M_{J+1} - M_J)}$$

Where:	C_J	=	tested concentration whose observed mean response is greater than $M_1(1 - p/100)$.
	C_{J+1}	=	tested concentration whose observed mean response is less than $M_1(1 - p/100)$.
	M_1	=	smoothed mean response for the control.
	M_J	=	smoothed mean response for concentration J.
	M_{J+1}	=	smoothed mean response for concentration J + 1.
	p	=	percent reduction in response relative to the control response.
	IC_p	=	estimated concentration at which there is a percent reduction from the smoothed mean control response. The IC_p is reported for the test, together with the 95% confidence interval calculated by the ICPIN.EXE program described below.

4.3 If the C_J is the highest concentration tested, the IC_p would be specified as *greater than* C_J . If the response at the lowest concentration tested is used to extrapolate the IC_p value, the IC_p should be expressed as a *less than* the lowest test concentration.

5. CONFIDENCE INTERVALS

5.1 Due to the use of a linear interpolation technique to calculate an estimate of the IC_p, standard statistical methods for calculating confidence intervals are not applicable for the IC_p. This limitation is avoided by use a technique known as the bootstrap method as proposed by Efron (1982) for deriving point estimates and confidence intervals.

5.2 In the Linear Interpolation Method, the smoothed response means are used to obtain the IC_p estimate reported for the test. The bootstrap method is used to obtain the 95% confidence interval for the true mean. In the bootstrap method, the test data Y_{ij} is randomly resampled with replacement to produce a new set of data Y_{ij}^* , that is statistically equivalent to the original data, but a new and slightly different estimate of the IC_p (IC_p^{*}) is obtained. This process is repeated at least 80 times (Marcus and Holtzman, 1988) resulting in multiple "data" sets, each with an associate IC_p^{*} estimate. The distribution of the IC_p^{*} estimates derived from the sets of resampled data approximates the sampling distribution of the IC_p estimate. The standard error of the IC_p is estimated by the standard deviation of the individual IC_p^{*} estimates. Empirical confidence intervals are derived from the quantiles of the IC_p^{*} empirical distribution. For example, if the test data are resampled a minimum of 80 times, the empirical 2.5% and the 97.5% confidence limits are approximately the second smallest and second largest IC_p^{*} estimates (Marcus and Holtzman, 1988).

5.3 The width of the confidence intervals calculated by the bootstrap method is related to the variability of the data. When confidence intervals are wide, the reliability of the IC estimate is in question. However, narrow intervals do not necessarily indicate that the estimate is highly reliable, because of undetected violations of assumptions and the fact that the confidence limits based on the empirical quantiles of a bootstrap distribution of 80 samples may be unstable.

5.4 The bootstrapping method of calculating confidence intervals is computationally intensive. For this reason, all of the calculations associated with determining the confidence intervals for the IC_p estimate have been incorporated into a computer program. Computations are most easily done with a computer program such as the revision of the BOOTSTRP program (USEPA, 1988; USEPA, 1989) which is now called "ICPIN" which is described below in subsection 7.

6. MANUAL CALCULATIONS

6.1 DATA SUMMARY AND PLOTS

6.1.1 The data used in this example are the mysid growth data used in the example in Section 14. The data is presented as the mean weight per original number of organisms. Table L.1 includes the raw data and the mean growth for each concentration. A plot of the data is provided in Figure L.1.

474

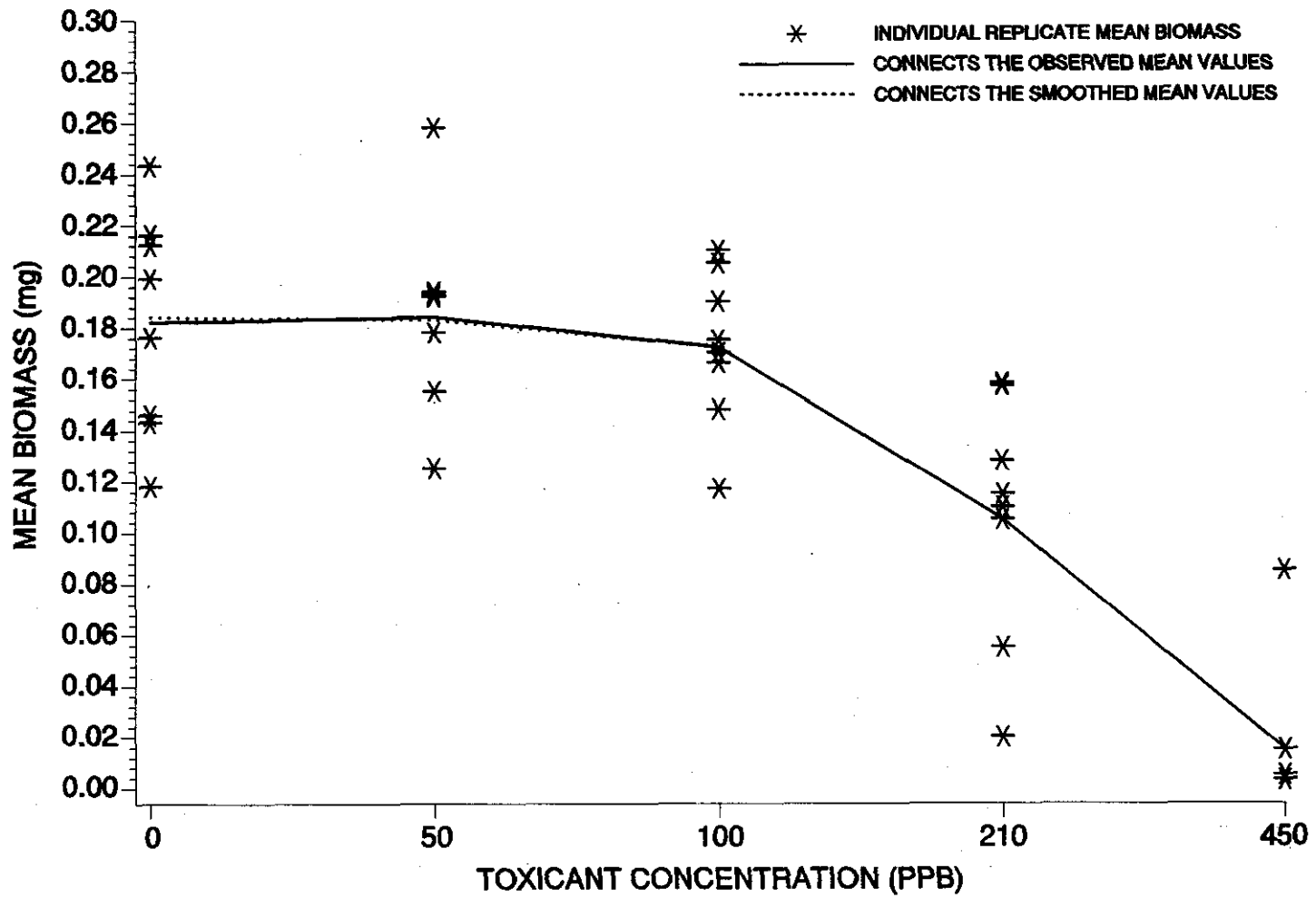

Figure L.1. Plot of raw data, observed means, and smoothed means for the mysid, *Mysidopsis bahia*, growth data.

20474

TABLE L.1. MYSID, *MYSIDOPSIS BAHIA*, GROWTH DATA

Replicate	Control	Toxicant Concentration (ppb)			
		50	100	210	450
1	0.146	0.154	0.114	0.153	0
2	0.118	0.193	0.172	0.094	0.012
3	0.216	0.190	0.160	0.017	0
4	0.199	0.190	0.199	0.122	0.002
5	0.176	0.256	0.165	0.052	0
6	0.243	0.191	0.145	0.154	0
7	0.213	0.122	0.207	0.110	0
8	0.144	0.177	0.186	0.103	0.081
Mean (\bar{Y}_i)	0.182	0.184	0.168	0.101	0.012
i	1	2	3	4	5

6.2 MONOTONICITY

6.2.1 As can be seen from the plot in Figure L.1, the observed means are not monotonically non-increasing with respect to concentration. Therefore, the means must be smoothed prior to calculating the IC.

6.2.2 Starting with the control mean $\bar{Y}_1 = 0.186$ and $\bar{Y}_2 = 0.184$, we see that $\bar{Y}_1 < \bar{Y}_2$. Calculate the smoothed means:

$$M_1 = M_2 = (\bar{Y}_1 + \bar{Y}_2) / 2 = 0.193$$

6.2.3 Since $\bar{Y}_5 = 0.025 < \bar{Y}_4 = 0.101 < \bar{Y}_3 = 0.168 < M_2$, set $M_3 = 0.168$ and $M_4 = 0.101$, and $M_5 = 0.025$. Table L.2 contains the smoothed means and Figure L.1 gives a plot of the smoothed response curve.

6.3 LINEAR INTERPOLATION

6.3.1 Estimates of the IC25 and IC50 can be calculated using the Linear Interpolation Method. A 25% reduction in mean weight, compared to the controls, would result in a mean weight of 0.139, where $M_1(1-p/100) = 0.185(1-25/100)$. A 50% reduction in mean weight, compared to the controls, would result in a mean weight of 0.093 mg. Examining the smoothed means and their associated concentrations (Table L.2), the two effluent concentrations bracketing the mean weight per original of 0.139 mg are $C_3 = 100$ ppb and $C_4 =$

TABLE L.2. MYSID, *MYSIDOPSIS BAHIA*, MEAN GROWTH RESPONSE AFTER SMOOTHING

Toxicant Conc. (ppb)	i	Smoothed Mean M _i (mg)
Control	1	0.183
50	2	0.183
100	3	0.168
210	4	0.101
450	5	0.025

210 ppb. The two effluent concentrations bracketing a response of 0.093 mg per total original number of organisms are C₄ = 210 ppb and C₅ = 450 ppb.

6.3.2 Using the equation from section 4.2, the estimate of the IC₂₅ is calculated as follows:

$$IC_p = C_J + [M_1 (1 - p/100) - M_J] \frac{(C_{J+1} - C_J)}{(M_{J+1} - M_J)}$$

$$IC_{25} = 100 + [0.193 (1 - 25/100) - 0.164] \frac{(210 - 100)}{(0.101 - 0.164)}$$

$$= 151 \text{ ppb}$$

6.3.3 Using Equation 1 from 4.2, the estimate of the IC₅₀ is calculated as follows:

$$IC_p = C_J + [M_1 (1 - p/100) - M_J] \frac{(C_{J+1} - C_J)}{(M_{J+1} - M_J)}$$

$$IC_{50} = 210 + [0.193 (1 - 50/100) - 0.101] \frac{(450 - 210)}{(0.028 - 0.101)}$$

$$= 239 \text{ ppb}$$

6.4 CONFIDENCE INTERVALS

6.4.1 Confidence intervals for the IC_p are derived using the bootstrap method. As described above, this method involves randomly resampling the individual observations and recalculating the IC_p at least 80 times, and determining the mean IC_p, standard deviation, and empirical 95% confidence intervals. For this reason, the confidence intervals are calculated using a computer program called ICPIN. This program is described below and is available to carry out all the calculations of both the interpolation estimate (IC_p) and the confidence intervals.

7. COMPUTER CALCULATIONS

7.1 The computer program, ICPIN, prepared for the Linear Interpolation Methods was written in TURBO PASCAL for IBM compatible PCs. The program (version 2.0) has been modified by Computer Science Corporation, Duluth, MN with funding provided by the Environmental Research Laboratory, Duluth, MN (Norberg-King, 1993). The program was originally developed by Battelle Laboratories, Columbus, OH through a government contract supported by the Environmental Research Laboratory, Duluth, MN (USEPA, 1988). A compiled, executable version of the program and supporting documentation can be obtained by sending a written request to EMSL-Cincinnati, 3411 Church Street, Cincinnati, OH 45244.

7.2 The ICPIN.EXE program performs the following functions: 1) it calculates the observed response means (\bar{Y}_i) (response means); 2) it calculates the standard deviations; 3) checks the responses for monotonicity; 4) calculates smoothed means (M_i) (pooled response means) if necessary; 5) uses the means, M_i , to calculate the initial IC_p of choice by linear interpolation; 6) performs a user-specified number of bootstrap resamples between 80 and 1000 (as multiples of 40); 7) calculates the mean and standard deviation of the bootstrapped IC_p estimates; and 8) provides an original 95% confidence intervals to be used with the initial IC_p when the number of replicates per concentration is over six and provides both original and expanded confidence intervals when the number of replicates per concentration are less than seven (Norberg-King, 1993).

7.3 For the IC_p calculation, up to twelve treatments can be input (which includes the control). There can be up to 40 replicates per concentration, and the program does not require an equal number of replicates per concentration. The value of p can range from 1% to 99%.

7.4 DATA INPUT

7.4.1 Data is entered directly into the program onscreen. A sample data entry screen is shown in Figure L.2. The program documentation provides guidance on the entering and analysis of data for the Linear Interpolation Method.

7.4.2 The user selects the IC_p estimate desired (e.g., IC₂₅ or IC₅₀) and the number of resamples to be taken for the bootstrap method of calculating the confidence intervals. The program has the capability of performing any number of resamples from 80 to 1000 as multiples of 40. However, Marcus and Holtzman (1988) recommend a minimum of 80 resamples for the bootstrap method be used and at least 250 resamples are better (Norberg-King, 1993).

ICp Data Entry/Edit Screen			Current File:			
	1	2	3	4	5	6
Conc. ID						
Conc. Tested						
Response 1						
Response 2						
Response 3						
Response 4						
Response 5						
Response 6						
Response 7						
Response 8						
Response 9						
Response 10						
Response 11						
Response 12						
Response 13						
Response 14						
Response 15						
Response 16						
Response 17						
Response 18						
Response 19						
Response 20						

F10 for Command Menu

Use Arrow Keys to Switch Fields

Figure L.2. ICp data entry/edit screen. Twelve concentration identifications can be used. Data for concentrations are entered in columns 1 through 6. For concentrations 7 through 12 and responses 21-40 the data is entered in additional fields of the same screen.

7.5 DATA OUTPUT

7.5.1 The program output includes the following (Figures L.3 and L.4)

1. A table of the concentration identification, the concentration tested and raw data response for each replicate and concentration.
2. A table of test concentrations, number of replicates, concentration (units), response means (Y_i), standard deviations for each response mean, and the pooled response means (smoothed means; M_i).
3. The linear interpolation estimate of the IC_p using the means (M_i).
Use this value for the IC_p estimate.
4. The mean IC_p and standard deviation from the bootstrap resampling.
5. The confidence intervals calculated by the bootstrap method for the IC_p. Provides an original 95% confidence intervals to be used with the initial IC_p when the number of replicates per concentration is over six and provides both original and expanded confidence intervals when the number of replicates per concentration are less than seven.

7.6 ICPIN program output for the analysis of the mysid growth data in Table L.1 is provided in Figures L.3 and L.4.

7.6.1 When the ICPIN program was used to analyze this set of data, requesting 80 resamples, the estimate of the IC₂₅ was 147.1702 (ppb). The empirical 95% confidence intervals for the true mean was 97.0905 to 186.6383 (ppb).

7.6.2 When the ICPIN program was used to analyze this set of data, requesting 80 resamples, the estimate of the IC₅₀ was 233.3311 (ppb). The empirical 95% confidence intervals for the true mean were 184.8692 to 283.3965 (ppb).

Conc. ID	1	2	3	4	5
Conc. Tested	0	50	100	210	450
Response 1	.146	.154	.114	.153	0
Response 2	.118	.193	.172	.094	.012
Response 3	.216	.190	.160	.017	0
Response 4	.199	.190	.199	.122	.002
Response 5	.176	.256	.165	.052	0
Response 6	.243	.191	.145	.154	0
Response 7	.213	.122	.207	.110	0
Response 8	.144	.177	.186	.103	.081

*** Inhibition Concentration Percentage Estimate ***

Toxicant/Effluent:

Test Start Date: Test Ending Date:

Test Species: MYSID SHRIMP, Mysidopsis bahia

Test Duration: growth test

DATA FILE: mysidwt.icp

OUTPUT FILE: mysidwt.i25

Conc. ID	Number Replicates	Concentration ug/l	Response Means	Std. Dev. Means	Pooled Response
1	8	0.000	0.182	0.043	0.183
2	8	50.000	0.184	0.038	0.183
3	8	100.000	0.168	0.030	0.168
4	8	210.000	0.101	0.047	0.101
5	8	450.000	0.012	0.028	0.012

The Linear Interpolation Estimate: 133.5054 Entered P Value: 25

Number of Resamplings: 80

The Bootstrap Estimates Mean: 147.1702 Standard Deviation: 23.7984

Original Confidence Limits: Lower: 96.8623 Upper: 186.6383

Resampling time in Seconds: 0.16 Random Seed: -1623038650

Figure L.3. Example of ICPIN program output for the IC25.

Conc. ID	1	2	3	4	5
Conc. Tested	0	50	100	210	450
Response 1	.146	.154	.114	.153	0
Response 2	.118	.193	.172	.094	.012
Response 3	.216	.190	.160	.017	0
Response 4	.199	.190	.199	.122	.002
Response 5	.176	.256	.165	.052	0
Response 6	.243	.191	.145	.154	0
Response 7	.213	.122	.207	.110	0
Response 8	.144	.177	.186	.103	.081

*** Inhibition Concentration Percentage Estimate ***

Toxicant/Effluent:

Test Start Date: Test Ending Date:

Test Species: MYSID SHRIMP, Mysidopsis bahia

Test Duration: growth test

DATA FILE: mysidwt.icp

OUTPUT FILE: mysidwt.i50

Conc. ID	Number Replicates	Concentration ug/l	Response Means	Std. Dev.	Pooled Response Means
1	8	0.000	0.182	0.043	0.183
2	8	50.000	0.184	0.038	0.183
3	8	100.000	0.168	0.030	0.168
4	8	210.000	0.101	0.047	0.101
5	8	450.000	0.012	0.028	0.012

The Linear Interpolation Estimate: 234.6761 Entered P Value: 50

Number of Resamplings: 80

The Bootstrap Estimates Mean: 233.3311 Standard Deviation: 28.9594

Original Confidence Limits: Lower: 184.8692 Upper: 283.3965

Resampling time in Seconds: 0.11 Random Seed: 1103756486

Figure L.4. Example of ICPIN program output for the IC50.

CITED REFERENCES

- Bartlett, M.S. 1937. Some examples of statistical methods of research in agriculture and applied biology. *J. Royal Statist. Soc. Suppl.* 4:137-183.
- Conover, W.J. 1980. *Practical nonparametric statistics*. Second edition. John Wiley and Sons, NY, NY. pp. 466-467.
- Dixon, W.J., and F.J. Massey, Jr. 1983. *Introduction to statistical analysis*. Fourth Edition. McGraw Hill, NY, NY.
- Draper, N.R., and J.A. John. 1981. Influential observations and outliers in regression. *Technometrics* 23:21-21.
- Dunnett, C.W. 1955. Multiple comparison procedure for comparing several treatments with a control. *J. Amer. Statist. Assoc.* 50:1096-1121.
- Dunnett, C.W. 1964. New table for multiple comparisons with a control. *Biometrics* 20:482.
- Efron, B. 1982. *The Jackknife, the Bootstrap, and other resampling plans*. CBMS 38, Soc. Industr. Appl. Math., Philadelphia, PA.
- Finney, D.J. 1971. *Probit analysis*. Third Edition. Cambridge Press, NY, NY. 668 pp.
- Finney, D.J. 1978. *Statistical method in biological assay*. Third Edition. Charles Griffin & Co. Ltd, London, England. 508 pp.
- Hamilton, M.A., R.C. Russo, and R.V. Thurston. 1977. Trimmed Spearman-Kärber method for estimating median lethal concentrations. *Environ. Sci. Tech.* 11(7):714-719.
- Marcus, A.H., and A.P. Holtzman. 1988. A robust statistical method for estimating effects concentrations in short-term fathead minnow toxicity tests. Manuscript submitted to the Criteria and Standards Division, U. S. Environmental Protection Agency, by Battelle Washington Environmental Program Office, Washington, DC. June 1988 under EPA Contract No. 69-03-3534. 39 pp.
- Miller, R.G. 1981. *Simultaneous statistical inference*. Springer-Verlag, New York, NY. 299 pp.
- Norberg-King, T.J. 1993. A linear interpolation method for sublethal toxicity: The inhibition concentration (IC_p) approach. Version 2.0. National Effluent Toxicity Assessment Center Technical Report 03-93, Environmental Research Laboratory, Duluth, MN 55804. June 1993.
- Scheffe, H. 1959. *The analysis of variance*. John Wiley, New York. 477 pp.

- Snedecor, G.W., and W.G. Cochran. 1980. Statistical Methods. Seventh edition. Iowa State University Press, Ames, IA. 593 pp.
- Steel, R.G. 1959. A multiple comparison rank sum test: treatments versus control. Biometrics 15:560-572.
- Stephens, M.A. 1974. EDF statistics for goodness of fit and come comparisons. J. Amer. Stat. Assoc. (JASA) 69:730-7737.
- USEPA. 1988. An interpolation estimate for chronic toxicity: The ICp approach. Norberg-King, T.J. Technical Report 05-88, National Effluent Toxicity Assessment Center, Environmental Research Laboratory, U. S. Environmental Protection Agency, Duluth, MN 55804.
- USEPA. 1989. Short-term methods for estimating the chronic toxicity of effluents and receiving waters to freshwater organisms. Second Edition. Weber, C.I., W.H. Peltier, T.J. Norberg-King, W.B. Horning, II, F.A. Kessler, J.R. Menkedick, T.W. Neiheisel, P.A. Lewis, D.J. Klemm, Q.H. Pickering, E.L. Robinson, J.M. Lazorchak, L.J. Wymer, and R.W. Freyberg (eds.). Environmental Monitoring Systems Laboratory, U. S. Environmental Protection Agency, Cincinnati, OH 45268. EPA/600/4-89/001.
- USEPA. 1993. Methods for measuring the acute toxicity of effluents and receiving waters to freshwater and marine organisms. Fourth Edition. Weber, C.I. (ed.). Environmental Monitoring Systems Laboratory, U. S. Environmental Protection Agency, Cincinnati, OH 45268. EPA/600/4-90/027F.

