

NOVEMBER 2023

Trash Assessment Methodology



Caltrans



I certify under penalty of law that this document and all attachments were prepared under my direction or supervision in accordance with a system designed to ensure that qualified personnel properly gather and evaluate the information submitted. Based on my inquiry of the person or persons who manage the system, or those persons directly responsible for gathering the information, the information submitted is to the best of my knowledge and belief, true, accurate, and complete. I am aware that there are significant penalties for submitting false information, including the possibility of fine and imprisonment for knowing violations. [40 CFR § 122.22(d)]

A handwritten signature in blue ink that reads "Elizabeth A. Doohar". The signature is written in a cursive style with a large, looped initial "E".

Elizabeth Doohar, Acting Chief Environmental Engineer
Division of Environmental Analysis
California Department of Transportation

Table of Contents

1.0 Executive Summary	1
2.0 Trash Assessment Inventory	7
3.0 Trash Assessment Schedule	15
4.0 Urban Assessment Criteria	16
5.0 Future Urban ROW Trash Assessment	21
6.0 Future Non-Urban ROW Trash Assessment	24
7.0 Maintenance Data Trash Dashboard	27
8.0 Other STGA Considerations	28
9.0 Full Trash Capture Equivalency	30
10.0 Interim Trash Reduction Milestones	35
11.0 Baseline Trash Volume	36
12.0 Annual Trash Reduction	37
13.0 Trash Assessment Implementation Deliverables	38

Attachment A:
Sample of Assessment and STGA Maps

Attachment B:
Trash Dashboard Portal Development Scope

Attachment C:
Caltrans Driving OVTA Protocol

Attachment D:
Level of Service Alternative Assessment

Attachment E:
Caltrans 2023 Encampment Survey Worksheet

Attachment F:
Urban Trash Discharge Design Study

Attachment G:
Non-Urban Initial Trash Rating Methodology

Attachment H:
Vegetation Control Study

1.0 Executive Summary

This document describes the California Department of Transportation’s (Caltrans) Trash Assessment Methodology (TAM) in compliance with the Caltrans National Pollutant Discharge Elimination System (NPDES) Permit (Order 2022-0033-DWQ) and, at least in part, the San Francisco Regional Water Quality Control Board (RWQCB) issued Cease and Desist (CDO) Order (Order No. R2-2019-0007 as amended by R2-2021-0030). The purpose of this TAM is to describe the Caltrans approach to comply Attachment E Section E.9 requirements of the Statewide Stormwater Permit (Permit) and to, the extent possible, comply with the San Francisco Bay Regional Water Board CDO. This TAM includes the necessary procedures to:

- **Identify Significant Trash Generating Areas (STGAs) within Caltrans’ right-of-way (ROW);**
- **Utilize alternative visual assessment methodologies;**
- **Demonstrate compliance with milestones;**
- **Demonstrate full capture equivalency; and**
- **Estimate annual trash reduction per year.**

Caltrans is proposing both the Driving On-Land Visual Trash Assessment (OVTA), Level of Service (LOS), and maintenance litter production Trash Dashboard to comply with the Permit, and in part, the CDO.

Table 1 below describes how Caltrans will implement the various trash assessments, including the schedule, by Urban and Non-Urban areas.

It should be noted that the TAM does not address trash implementation necessary to achieve compliance with the Permit. The Permit requires Caltrans to submit a Trash Implementation Plan six (6) months subsequent to approval of the TAM.

Table 1: Trash Assessment Methodology & Schedule by Area Types

Urban Areas	
Date Range	Assessment Methodology
2018 - 2019	OVTAs conducted at 849 centerline miles of high traffic urbanized areas
Mar 2020 – Nov 2023	Vegetation Control Study
Dec 2023 – June 2024	OVTAs conducted 1,974 centerline miles of urban areas not previously assessed
Mar 2023 – July 2025	Paved Area Trash Discharge Study that includes 40 high traffic locations within the jurisdictions of the Los Angeles and San Francisco Regional Water Board
2026, 2028, 2030	<ul style="list-style-type: none"> • Biannual LOS, or OVTA, visual trash assessment of moderate, high, and very high STGA where full capture equivalency has been attained. • Biannual trash dashboard or CSR indicator assessments of low trash generating areas

Non-Urban Areas	
Date Range	Assessment Methodology
Sept 2023 – Dec 2023	Integrated Maintenance Management System (IMMS) Trash Dashboard Development
Dec 2023 – Apr 2024	Initial IMMS Ratings of 10,794 centerline miles as automated through the Trash Dashboard Model
Apr 2024 – Dec 2024	Confirmation OVTAs conducted at 500 centerline miles of low, moderate, high, or very high segments
Mar 2023 – July 2025	Paved Area Trash Discharge Study that includes 30 locations (including 10 high traffic locations between regulated MS4s) within the jurisdictions of the North Coast and San Francisco Water Boards
April 2024 - June 2026	Final IMMS Rating reconciliation of 10,794 centerline miles as automated through the Trash Dashboard Model; refined through discharge studies and IMMS optimization
2026, 2028, 2030	<ul style="list-style-type: none"> • Biannual LOS, or OVTA, visual trash assessment of moderate, high, and very high STGA where full capture equivalency has been attained • Biannual trash dashboard or CSR indicator assessments of low trash generating areas

1.1 Future Trash Assessment to Demonstrate Full Capture Equivalency

Caltrans is currently, and is proposing, performing trash discharge studies at a total of 99 urban and non-urban locations to establish a maintenance activity performance standard that reduce trash discharges to the storm drain system at an equivalent level of that of certified full trash capture systems (Systems). These studies include the installation of Systems and measurement of trash entering the Systems. Caltrans understands that the results of the trash discharge studies may require the installation of additional Systems at certain locations needed to demonstrate full capture equivalency. The State and Regional Water Boards will be consulted during the studies and as data is gathered to discuss any needed adaptive management and evaluate compliance.

1.2 Statewide Trash Provisions

The Trash Provisions became effective on December 2, 2015 and prohibit the discharge of trash to surface waters of the State or the deposition of trash where it may be discharged into surface waters of the State. The Trash Provisions require Caltrans to identify STGAs within its ROW and install and implement a combination of Systems, institutional controls, and other treatment controls that meet full capture equivalency. On June 1, 2017, The State Water Board issued a 13383 Order requiring Caltrans to begin planning to comply with the Trash Provisions. Caltrans submitted a Statewide Trash Implementation Plan (2019 Plan) in response to the 13383 Order.



1.3 Los Angeles Region Trash Total Maximum Daily Load

The Permit includes the implementation requirements for the Total Maximum Daily Load (TMDLs) that include trash waste load allocations adopted by the Los Angeles Regional Water Board. These are:

- **Ballona Creek**
- **Legg Lake**
- **Los Angeles Area (Echo Park Lake)**
- **Los Angeles Area (Peck Road Park Lake)**
- **Los Angeles River**
- **Machado Lake**
- **Malibu Creek**
- **Revolon Slough and Beardsley Wash**
- **Santa Monica Bay**
- **Ventura River Estuary**

Trash waste load allocations are the gallons of trash per year that Caltrans is required to remove or reduce from its stormwater discharges to satisfy its trash TMDLs. TMDL compliance progress is updated in the Caltrans Annual TMDL Compliance Status Report, which is submitted as an attachment to its Annual Report. An existing trash reduction program is in place to address the 474 centerline miles associated with TMDLs. Therefore, those areas are not included in this TAM.



1.4 San Francisco Regional Water Board Trash Discharge CDO

The CDO requires Caltrans to implement trash reduction measures to comply with trash reduction benchmarks for the 1,036 centerline miles subject to the CDO. The CDO mandates annual reports be submitted to the San Francisco Regional Water Board. Caltrans has developed a Trash Control Implementation Workplan to comply with the trash reduction program required by the CDO.

Both the permit and CDO requires Caltrans to demonstrate full capture equivalency at all STGAs where certified Systems are not installed. Although this TAM is designed to specifically meet the trash assessment requirements of the Permit, various aspects of the TAM may apply to the CDO with approval by the San Francisco Regional Water Board.

To date, Caltrans efforts to comply with CDO include:

- **Conducting trash reduction feasibility studies;**
- **Programming and implementing trash control projects through the State Highway Operations Protection Program (SHOPP) projects on Caltrans ROW;**
- **Funding regional partnership projects that address trash from Caltrans and local municipalities outside of Caltrans ROW;**
- **Performing extensive trash reduction efforts such as comprehensive litter collection and freeway sweeping in entire corridors, incident litter removal from illegal dumping and encampment, and trash removal from vegetation controls; and**
- **Implementing trash reduction public education and outreach programs.**

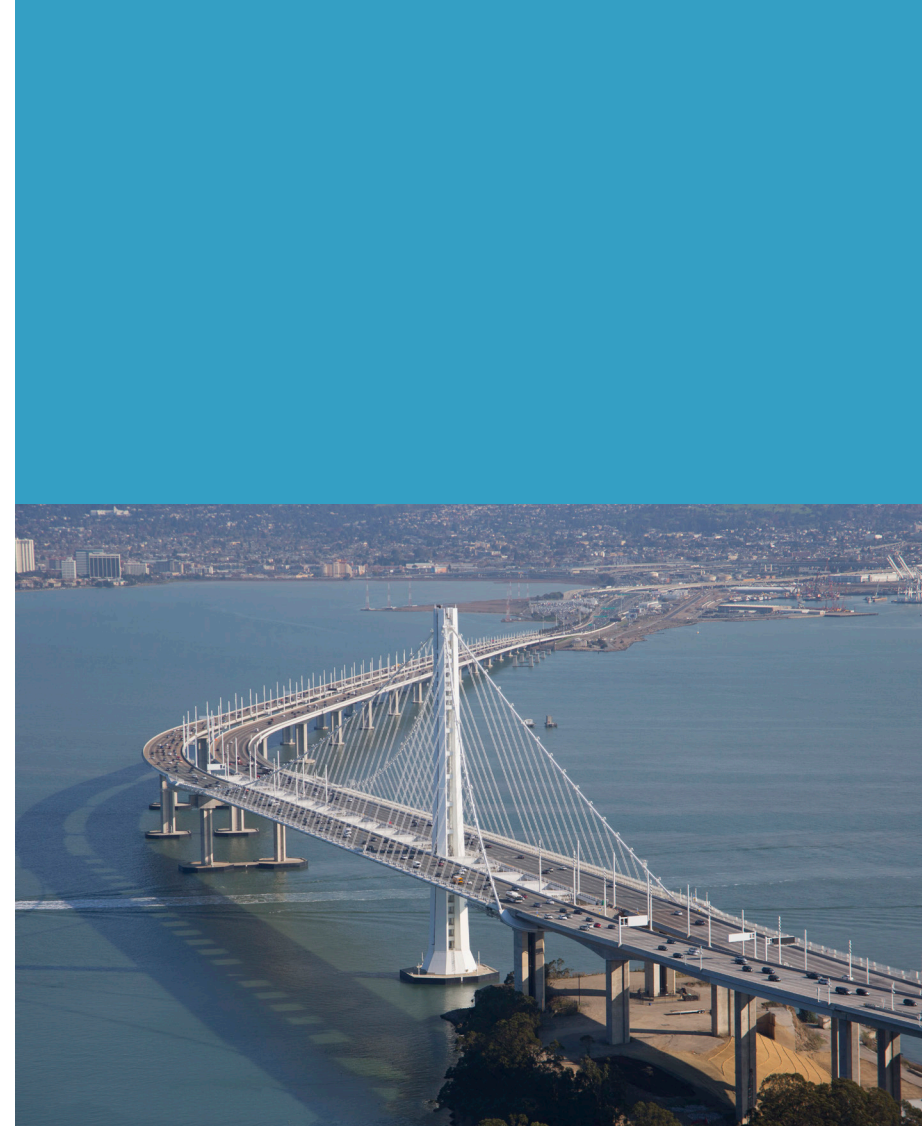

1.5 Caltrans Statewide NPDES Permit

The Caltrans Statewide NPDES Permit (Permit) became effective January 1, 2023.

Table 2 provides the Permit’s trash assessment requirements and the sections of the TAM that addresses each requirement.

Table 2: TAM Sections and Attachment E NPDES Permit References

Attachment E Permit Reference	Permit Requirement Description	TAM Section
E9.1	Assessment within MS4	Section 4.0: Urban MS4 Assessment Section 5.0: Future Urban ROW Trash Assessment
E9.2.a	Implementation Schedule	Section 3.0: Trash Assessment Schedule
E.9.2.b	GIS Mapping of STGAs	Section 2.4: Geospatial Information System (GIS) STGA Mapping
E.9.2.c	Full Trash Capture Equivalency	Section 9.0: Full Trash Capture Equivalency
E.9.2.d	Compliance with interim Milestones	Section 10.0: Interim Trash Reduction Milestones
E.9.2.e	Annual Trash Reduction	Section 12.0: Annual Trash Reduction
E.9.3.a	Assessment Outside of MS4	Section 6.0: Future Non-Urban ROW Trash Assessment
E.9.3.b	Assessment within MS4	Section 4.0 Urban MS4 Assessment Section 5.0: Future Urban ROW Trash Assessment
E.9.3.c	Homelessness	Section 8.4 Homeless Encampments
E.9.3.d	Substitute for visual assessment	Section 4.2 LOS Alternative Visual Assessment Section 6.0 Future Non-Urban ROW Trash Assessment Section 9.2 Trash Discharge Studies
E9.3.e	Locations where substitutes for visual assessment performed	Section 6.0 Non-Urban ROW Trash Assessment Section 9.2 Trash Discharge Studies
E9.4	Baseline Assessment Volume Results	Section 11.0: Baseline Trash Volume

2.0 Trash Assessment Inventory

Caltrans has conducted OVTAs in response to the 2019 CDO and the State Water Board’s 13383 Order at 1,885 urban centerline miles of ROW to determine STGAs. Caltrans did not conduct OVTAs at 10,794 non-urban centerline miles of ROW, ROW subject to TMDLs, and 1,974 urban centerline miles that did not meet the desktop criteria utilized in the 2019 Plan (and now revised).

Caltrans trash assessment methodology for urban ROW is different than for non-urban ROW as described below. Caltrans is implementing a phased approach that prioritizes trash assessment of the urban ROW first, and then the non-urban ROWs.



2.1 Caltrans Jurisdictional Profile

Caltrans is responsible for maintaining California’s state highway system which includes 15,127 centerline miles of highway. In response to the 13383 Order, Caltrans assessed 849 centerline miles in urbanized areas and reported the results in its 2019 Plan. This does not include the 1,036 centerline miles already assessed to comply with the CDO.

This TAM provides the steps and schedule to assess the 1,974 remaining urban centerline miles and 10,794 non-urban centerline miles of Caltrans ROW that were not included in its previous 2019 Plan. As required by Attachment E Section E.9 of the Permit, this TAM provides the trash assessment methods that will be used to determine the amount of STGAs in the remaining urban and non-urban areas.

Table 3 summarizes the Caltrans centerline miles that have been assessed and not assessed.

Table 3: Caltrans Highway System Breakdown within Urban and Non-Urban

Caltrans Jurisdictional Inventory		
	Description	Centerline Miles
1	Urban Miles Assessed	849
2	Urban Miles Not Assessed	1,974
3	Non-Urban Miles Not Assessed	10,794
4	Urban Miles in San Francisco Oakland Bay Area assessed (Caltrans District 4)	1,036
5	Urban TMDL Miles in Los Angeles Area - assessment not applicable (Caltrans District 7)	474
	Total	15,127

2.2 Existing STGA Inventory

To determine STGAs for the 2019 Plan, Caltrans conducted OVTAs at:

- 849 high-traffic urbanized centerline miles;
- 380 Park and Rides; and
- 87 Rest Areas.

As allowed by the Trash Provisions, desktop methodology was applied as an alternative to conducting OVTAs when producing the 2019 TAM. Implementation of the desktop methodology excluded all non-urban centerline miles and 1,974 urban centerline miles that did not meet the desktop criteria utilized in the 2019 Plan.

Caltrans automatically designated Park and Ride and rest area facilities as moderate STGAs. This designation was generally confirmed while completing the 2019 Plan.

The Permit noted specific deficiencies in the Caltrans 2019 Plan. As a result, Caltrans will conduct OVTAs at 1,974 urban centerline miles were not previously assessed. OVTAs will not be conducted at centerline miles where moderate, high or very high STGAs ratings have already been assigned. Moderate areas claimed as full capture equivalent and low areas will be reassessed in 2026 as outlined in sections 5.2.1 and 5.2.2.

Table 4 summarizes the acreage of Caltrans current STGAs by districts and ROW type.

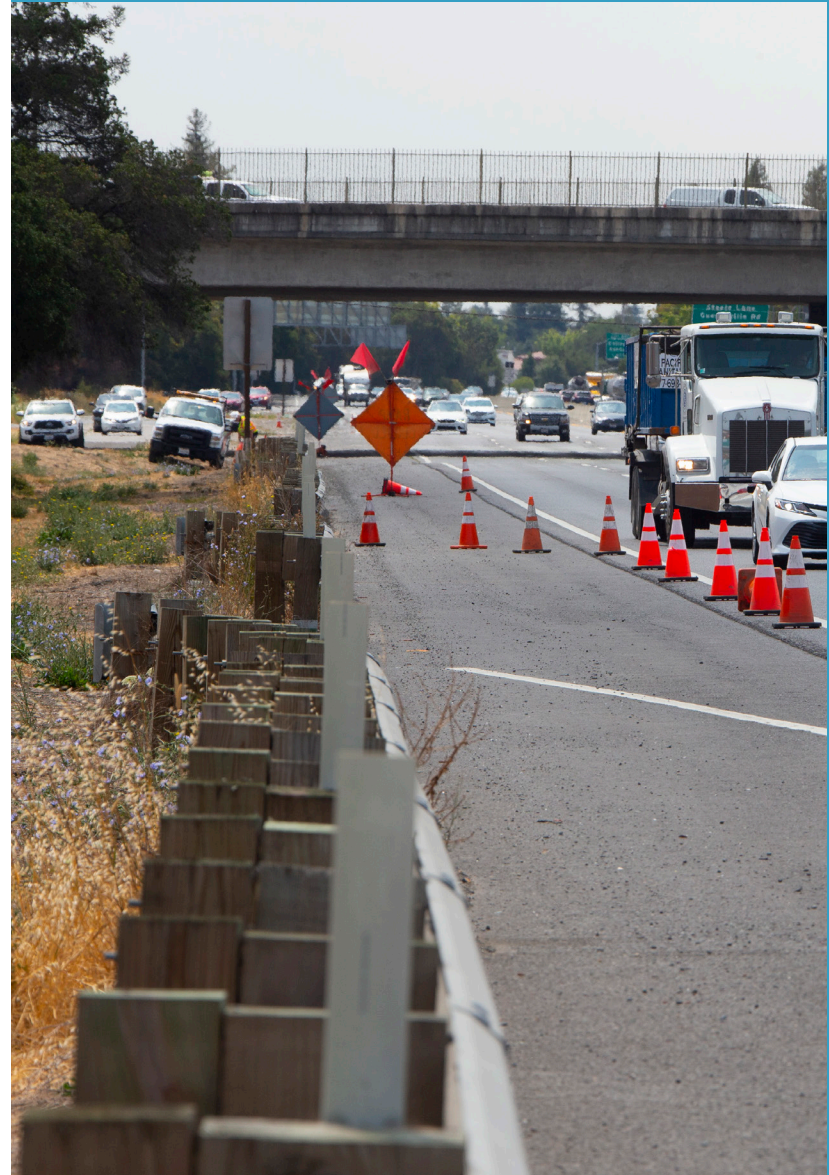

Table 4: District STGA Acreage by ROW Type

District	Highway Acreage	Ramp Acreage	Park and Ride Acreage	Rest Area Acreage	Total Acreage
1	0	94	0	0	94
2	0	561	0	0	561
3	1,110	1,293	17	0	2,419
4	24	9	7	0	40
5	366	1,505	2	0	1,872
6	75	757	1	0	833
7	951	1,420	69	0	2,440
8	3,061	3,485	36	12	6,594
9	0	0	0	0	0
10	340	536	1	21	898
11	1,909	2,116	21	28	4,074
12	1,231	1,633	5	0	2,869
Totals	9,066	13,405	159	61	22,691

Note: Table excludes acreage under CDO and TMDL enforcement.

To calculate acreage, Caltrans employed the following:

- Directional Hwy Segment Length = 0.5 mile
- Lane width = 12 feet
- Shoulder width = 8 feet
- Impervious/Pervious ratio = 60% Impervious/40% Pervious
- Total acreage calculated by first calculating impervious, then multiplying by 5/3 to add in the assumed 40% pervious acreage

Calculation:

- Directional highway acreage estimates = $\{ \text{Length of Segment} * [(\# \text{lanes} * 12' \text{ lane width}) + (8' \text{ shoulder width})] \} * 5/3$

Note: This acreage estimating calculation was originally developed and completed in 2018 for TMDL compliance. The calculation provides statewide consistency.

- The acreage for ramps was defined as both the on- and off-ramp portions associated with one direction of travel. Ramps were assumed an average of 8.5 acres per ramp. This was derived by taking closely delineated acreages for 10 large ramps and calculating the average acreage = 8.5 acres.
- The acreage for park and ride were calculated assuming a 500 square foot area per parking space multiplied by the number of spaces.
- The acreage for rest areas were calculated using feature-specific polygons in GIS (i.e., exact).



2.3 Current STGA Trash Rating by District

The 2019 Plan resulted in the following STGA trash ratings in each District as provided in Table 5.

Table 5: STGA Acreage Rating Breakdown

District	Very High	High	Moderate	Low	Unrated Urban	Unrated Non-Urban	Total Acreage
1	0	0	94	136	0	9,696	9,925
2	0	0	561	340	802	14,837	16,540
3	24	1,919	476	2,400	1,963	12,476	19,258
4	0	31	9	1,280	1,392	2,750	5,461
5	0	752	1,120	404	3,546	8,569	14,391
6	0	144	689	1,318	4,009	17,697	23,856
7	0	1,893	547	559	7,586	3,356	13,940
8	25	4,382	2,187	734	5,467	14,458	27,252
9	0	0	0	0	0	6,683	6,683
10	14	774	111	621	2,925	10,371	14,815
11	33	3,799	242	888	5,763	6,980	17,704
12	41	2,615	213	213	4,473	29	7,583
Total	137	16,308	6,246	8,891	37,926	107,900	177,409

2.4 GIS STGA Mapping

GIS connects data to a map, integrating location data (where things are) with all types of descriptive information (what things are like there). This provides a foundation for mapping and analysis that is used in science in almost every industry. GIS helps users understand patterns, relationships, and geographic context. The benefits include improved communication and efficiency as well as better management decisions.

As required by the Permit and explained below, Caltrans will conduct OVTAs on urbanized ROW not included in its 2019 Plan. The GIS maps will be updated with the results of these assessments. Areas pending assessment are identified in blue linework.

Attachment A are examples of maps presenting the ROW with completed trash assessments and associated Low, Moderate, High, and Very High trash ratings.

The attachments also include what future maps would look like for non-urban ROW.

The Headquarters Division of Environmental Analysis GIS unit serves as Caltrans focal point for GIS software deployment, acquisition and maintenance of geospatial data and imagery, web map service deployment, and GIS technical support.

The GIS unit is comprised of GIS professionals with a wide array of knowledge and expertise to support the following initiatives:

- Geospatial data and aerial imagery acquisition and delivery
- GIS data library maintenance
- Software technology and data integration with CADD applications
- GIS analysis and mapping to support capital project delivery
- Development of models, tools, and scripts to support workflow automation
- Web mapping solutions
- Technical support for statewide GIS users
- Develop and maintain partnerships within the GIS community

Maps are available for view by accessing the web viewer at the following URL:
<https://experience.arcgis.com/experience/543e95ec5eed4339a4733a890de4697c/>

As assessments are completed, STGAs will be populated on a GIS layer that will include the following features:

- County
- Route
- Post miles
- Route shields
- Interchange area
- Areas under raised roads
- Safety roadside rest areas
- MS4 hatching
- Regional board boundaries
- Caltrans District boundaries
- Receiving water bodies
- Storm drain network (if available)
- Environmentally sensitive areas
- CalEnviro screen 4.0
- **Trash ratings**
 - **very high = purple line work**
 - **high = red line work**
 - **moderate = yellow line work**
 - **low = green line work**
 - **pending assessment = blue**

Before trash assessment data can be used in a GIS, the data from field assessments must be converted into a suitable digital format. The process of converting data from field determinations into computer files is called digitizing.

Caltrans Headquarters will manage and oversee fieldwork, database creation, attribute data collection, digitizing, map creation, and symbology.

Upon completion of its trash assessment efforts, Caltrans will update its trash assessment GIS database and develop a revised Trash Assessment Map per requirements in E.10 of the Permit.

3.0 Trash Assessment Schedule

The Permit requires Caltrans to conduct trash assessment following the OVTA methodology and/or or develop an alternative methodology subject to approval. The OVTA methodology was developed for municipal areas and not for Caltrans ROW which includes high traffic volume urban ROW, non-urban ROW, and other unique features. However, Caltrans will employ the OVTA method within urban MS4 ROW and the Trash Dashboard Model method within non-urban ROW to identify STGAs. The following describes Caltrans trash assessment schedule for measuring trash accumulation in a geographically defined approach. The protocols and methods identified herein are consistent with the requirements of the Permit.

Table 6: Trash Assessment Implementation Schedule

Caltrans Trash Assessment Implementation Schedule				
Phase	Start	End	Assessment Area	Assessment Method
I	2018	2019	Urban ROW	OVTA
II	12/1/2023	6/30/2024	Remaining Urban ROW	OVTA
III	9/1/2023	3/31/2024	Non-Urban ROW	Trash Dashboard Model - Initial Rating (See Attachments B & G)
IV	4/1/2024	9/1/2024	STGAs in Non-urban ROW	Modified OVTA (See Attachment C)
V	9/1/2023	6/30/2026	Non-Urban ROW	Trash Dashboard Model - Final Rating (See Attachments B & G)
V1	2026	2030	All Urban ROW	Bi-annual LOS, or OVTA, at Full Capture Equivalent STGAs + Low Rated Area Assessments + Trash Discharge Evaluation
VII	2026	2030	All Non-Urban ROW	Bi-annual LOS, or OVTA, at Full Capture Equivalent STGAs + Low Rated Area Assessments + Trash Discharge Evaluation

4.0 Urban Assessment Criteria

The Permit requires Caltrans to visually assess all urban ROW within or adjacent to any regulated MS4 (Phase I and Phase II Permittee jurisdictions) to identify STGAs.

Caltrans will use the OVTA trash assessment rating as displayed in Table 7.

Table 7: OVTA Ratings

OVTA Rating	Criteria Description
Low – Not Littered	<p>Effectively no trash is observed in the assessment area.</p> <p>Approximately less than one piece per two car lengths on average.</p> <p>There may be some small pieces in the area, but they are not obvious at first glance.</p> <p>One individual could easily clean up all trash observed in a very short timeframe.</p>
Moderate – Slightly Littered	<p>Predominantly free of trash except for a few littered areas.</p> <p>On average, one piece per two car lengths.</p> <p>The trash could be collected by one or two individuals in a short period of time.</p>
High – Littered	<p>Predominantly littered except for a few clean areas.</p> <p>Trash is widely/evenly distributed and/or small accumulations are visible.</p> <p>At least two or three pieces per car length on average.</p> <p>It would take a more organized effort to remove all trash from the area.</p>
Very High – Very Littered	<p>Trash is continuously seen throughout the assessment area.</p> <p>Large piles and a strong impression of lack of concern for litter in the area.</p> <p>There is often significant litter.</p> <p>It would take a large number of people during an organized effort to remove all trash from the area.</p>

4.1 Reduced Speed OVTAs

The OVTA methodology assumes that assessments are performed by walking individual segments and judging a trash generation rating. For safety considerations, this is not possible for freeways and highways. The 2019 OVTAs were conducted at regular traffic speeds up to 65 mph. In order to improve the accuracy of visual assessments, Caltrans will maximize efforts to perform OVTAs at speeds of 25 MPH or less for each ½ mile segment.

Slow speed OVTAs can be accomplished either:

1. During rush hour traffic; or
2. Moving lane closure.

When targeting rush hour to achieve the slow speed for assessments, there may be limited circumstances where the flow of traffic may result in a speed in excess of 25 MPH. In these situations, assessors will note the segment and speed and rely on the video footage that will be played back at a slow speed equivalent to a driving speed of 25 MPH or less. The assessor will then assign the trash rating for the segment(s) based on the subsequent video review.



4.2 LOS Alternative Visual Assessment

LOS evaluates and reports how the Division of Maintenance is maintaining the State Highway System. LOS scores are generated by evaluating ROW throughout the State Highway System. This assessment enables Caltrans to monitor performance and adaptively manage the frequency of litter collection activities. Caltrans has been performing quarterly LOS assessments since July 2021 for legislative accountability reporting toward measurable objectives and performance outcomes associated with Governor Newsom's Clean CA initiative. The results, to date, reveal increasing systemwide litter removal as a result of increasing resources dedicated to litter abatement efforts.

Caltrans evaluates 2,547 highly trafficked one-mile segments of highway statewide on a quarterly basis. For consistency, the same highway segments are evaluated using the LOS visual assessment each quarter. During the LOS assessments process, Caltrans maintenance supervisors assign scores to each segment based on the density of trash on the roadsides at that point in time. Scores range from zero to 100, with 100 being the best. These numeric ratings are translated to maintenance need scores ranging from 0, 1 and 2.

OVTA and LOS are both visual assessments that are closely comparable. To optimize resources, Caltrans is utilizing both assessment types for assessment and compliance efforts to demonstrate progress toward regulatory trash compliance objectives.

LOS trash assessment is different from OVTA in that it evaluates all trash regardless of its size. Further, LOS evaluates 1-mile segments and assigns ratings based on trash within 1/10-mile sections, which is less than the 0.5-mile OVTA segments. Therefore, LOS can be used in lieu of OVTA to demonstrate progress toward full capture equivalency and other regulatory trash obligations.

Further justification of LOS visual assessments is presented in Attachment D.

4.3 Trash Rating Area Delineation

Caltrans is responsible for conducting, determining, and documenting the OVTAs. This data is sent to Caltrans Headquarters to be entered into a GIS database. The GIS database is programmed to calculate the acreage associated with each OVTA. In general, the GIS database currently calculates acreage from the number of lanes and shoulders and dimensions that generalize the entire right-of-way, as opposed to defining only the areas where trash accumulates. Ramps are assigned the same rating as the main lane assessment and a generic average acreage of 8.5 acres assigned to each ramp.

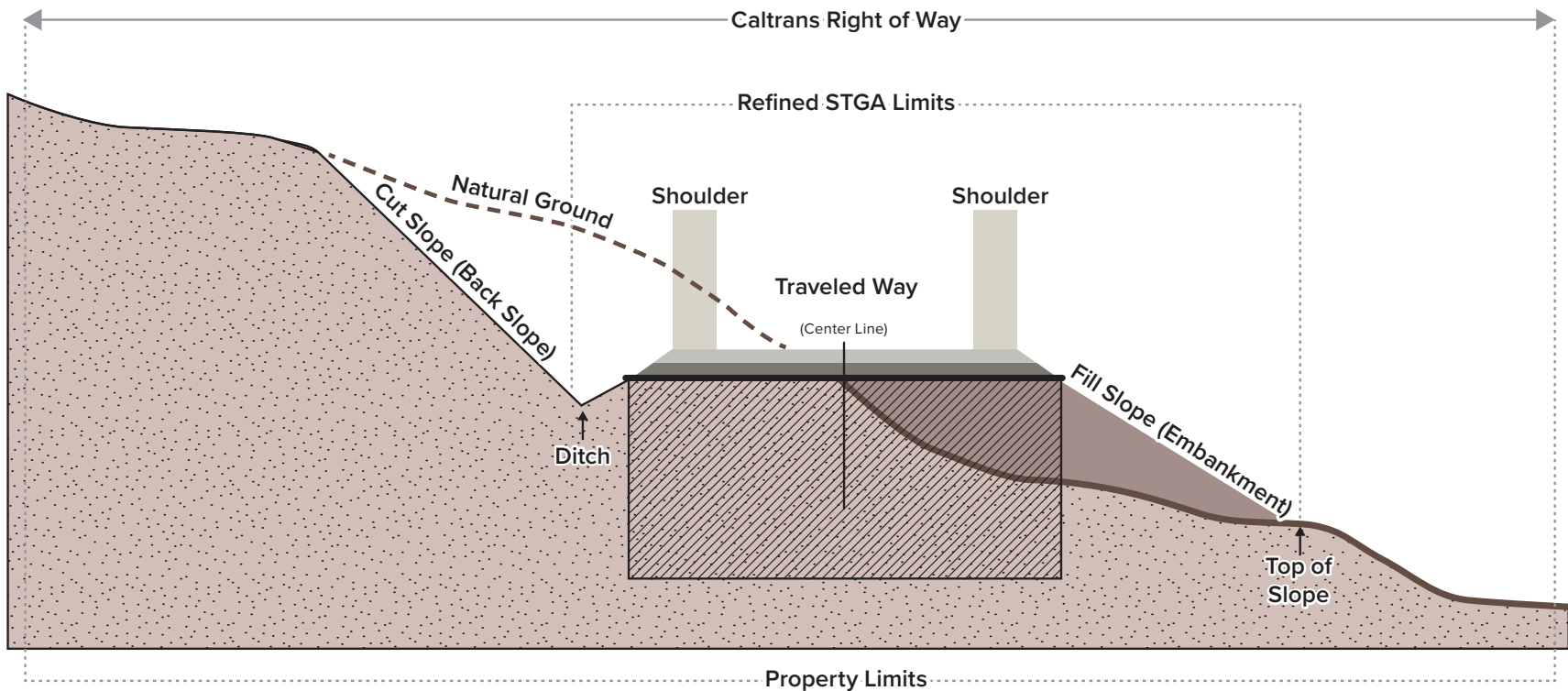

Caltrans has determined that the current system to calculate acreage is overbroad and needs refinement. Over the next two-year period, Caltrans will obtain additional data to make this refinement. The following criteria will be considered when establishing a more refined STGA delineation framework for defining the lateral boundaries of STGAs where trash accumulates:

- **Proximity to receiving water**
 - Geographic sensitivity
- **Hydraulic connectivity**
- **Soil type / Infiltration**
- **Distance from centerline to ROW line**
- **Slope Inclination i.e., 4:1 or greater**
- **Visual observations**
- **Geometric cross -section**
- **Worker safety**

Historically, as freeways were designed and constructed, a cut-and-fill approach was utilized to minimize cost. Cut-and-fill is a method of road construction in which a road is built by cutting into the hillside and spreading the spoil materials in adjacent low spots and as compacted or side-cast fill slope material along the route. A “balanced cut-and-fill” utilizes all of the “cut” material to generate the “fill.” In a balanced cut-and-fill design there is no excess waste material and there is no need for hauling additional fill material. Thus, cost is minimized.

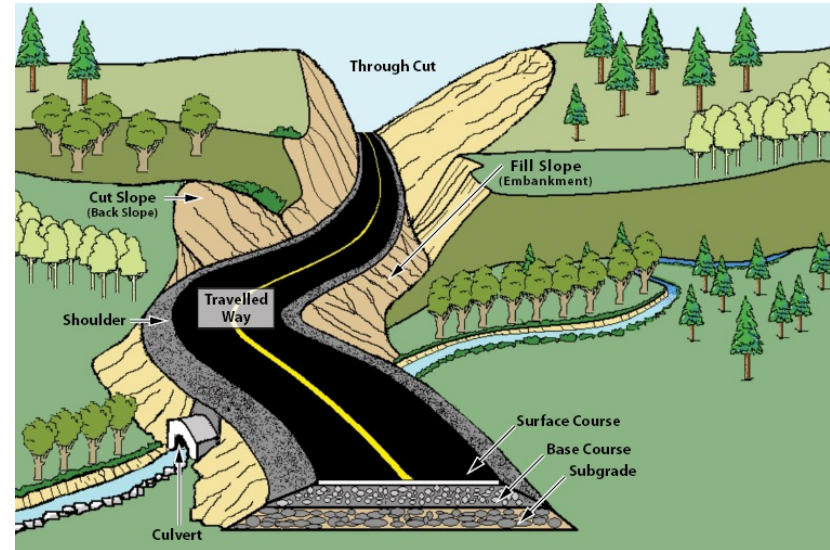

Given this information, along with Safety considerations and trash accumulation field observations, STGA delineation will be confined to the first ten feet of a cut-slope with a slope inclination of 4:1 or steeper.

District maintenance managers will also review the STGAs to provide additional field verified refinements to accurately delineate the actual areas where trash accumulates. Any reduction in footprint will require documentation and supporting photos.

5.0 Future Urban ROW Trash Assessment

Caltrans has calculated that approximately 1,974 urban centerline miles (see columns 2 and 3 in Table 8 below) will be assessed to comply with Permit.

Table 8: Total Centerlines Pending Assessment

District	Non-Urban Centerline Miles	Urban Centerline Miles	Total Centerline Miles
1	941	0	941
2	1,672	47	1,719
3	1,266	127	1,393
4	284	92	376
5	844	276	1,120
6	1,764	229	1,993
7	273	292	566
8	1,336	343	1,680
9	736	0	736
10	1,132	162	1,294
11	676	206	882
12	4	200	203
Totals	10,928	1,974	12,904

5.1 Re-Assessment of Prior Identified Urban STGAs

Prior to deployment of any new or enhanced trash treatment controls for STGAs identified as part of the 2019 Plan, each Caltrans District maintenance manager will inspect each identified urban STGA to verify and document the current OVTA trash generation rating, using the Level of Service methodology, to:

- **Validate the OVTA rating;**
- **Determine if trash treatment controls are appropriately implemented; and**
- **Determine if additional trash treatment controls are needed.**

Consistent with the OVTA methodology, Caltrans District maintenance managers will conduct these inspections approximately midway between litter removal activities.

After identifying STGAs through OVTAs, Caltrans may elect to substitute LOS for OVTA at some or all locations for the biannual trash assessments as described in section 4.2 and Attachment D. If Caltrans elects to substitute LOS for OVTA, Caltrans will notify the State Water Board of the locations to request State Water Board's concurrence.

5.2 Urban Bi-annual Assessments

Caltrans will implement the following ongoing future reassessments to ensure compliance with interim and final compliance milestones.

5.2.1 Full Capture Equivalence Assessments

Caltrans will perform biannual driving visual assessments, using either LOS or OVTA, of all moderate, high, and very high rated areas, that have been claimed as full capture equivalence, to ensure sustained compliance over time. Visual assessments will indicate if institutional controls are sufficiently addressing deviations in trash generation through the final compliance date.

These assessments will be conducted in accordance with Attachment D.

5.2.2 Low Area Assessments

Caltrans will perform assessments of low rated areas using the following tools to track deviations in trash generation over time:

1. **Trash Dashboard to monitor IMMS work order litter collection and expenditures**
2. **Customer Service Request (CSR) data.**

The Trash Dashboard and CSR indicators will assist in informing Caltrans:

- Where to focus trash collection resources to reduce trash discharges.
- Determining the actual amount of trash discharged.
- Evaluate the spatial distribution and temporal changes in trash generation to evaluate the overall effectiveness of both the urban trash control programs.
- Determine if additional visual assessments are required to identify additional STGAs



6.0 Future Non-Urban ROW Trash Assessment

There are 10,794 centerline miles in Caltrans non-urban ROW. As provided by the Permit, Caltrans may use an assessment model to identify STGAs for non-urban ROW. To manage existing resources, Caltrans will identify STGAs in non-urban ROW in three (3) major phases as explained below.

Caltrans will establish a non-urban ROW low trash rating threshold by correlating annual litter removal to low-rated control sites within the San Francisco Regional Board CDO enforcement area. Six trash generating areas within the San Francisco Regional Board trash discharge CDO area were evaluated to determine annual litter production for the purposes of correlating these control sites and applying the results to establish a low rating threshold for non-urban ROW of the state that require trash assessment.

The Non-Urban Initial Trash Rating Methodology is outlined in Attachment G.

2022 annual litter production metrics were evaluated from control sites associated with the CDO to compare against unrated non-urban sites that have been assumed to be low trash generation inherent with low traffic volume and population characteristics. The results indicate a 30 cubic yards per mile per year threshold correlates to low trash generation rating for a 2-lane state route when compared to the control sites under the CDO enforcement.

6.1 Phase 1: Non-Urban 500 Mile Study

Caltrans shall conduct confirmation OVTAs for 500 representative centerline miles of non-urbanized high traffic highways that have been assigned a low rating from the Maintenance Trash Dashboard Model presented herein. The areas selected were assigned low trash ratings based on Caltrans IMMS records that track litter production.

OVTAs will be conducted in accordance with the “Caltrans Driving On-Land Visual Trash Assessment Protocol”, Attachment C of the TAM.

The geographically diverse locations where OVTA assessments will be compared to the model, along with a complete assessment of litter production thresholds of various multi-lane state route scenarios in cubic yards/mile/year and associated methodology to calculate the equivalent OVTA discharge rates, is included in the Non-Urban Initial Trash Rating Methodology in Attachment G.

6.2 Phase 2: Non-Urban Trash Capture Study

Caltrans shall install certified Systems to determine how much trash gets into storm drain inlets while correlating the maintenance effort to meet full trash capture equivalency. Thirty (30) locations were selected based on trash ratings and Caltrans IMMS records. The following breakdown further describes the site selection criteria.

- **Twenty (20) low rated non-urban highway locations within the jurisdiction of the North Coast Water Board that discharge to receiving waters. Caltrans will measure the annual amount of trash trapped by Systems starting in 2023 over a two-year period; and**
- **Ten (10) low and moderate rated non-urban locations within the jurisdiction of the San Francisco Water Board that discharge to receiving waters and that have high traffic volumes similar to nearby urban freeways.**

If the study verifies low trash ratings, it will be assumed that other low rated locations are also low, as further described in Section 9.2 and Attachments F and G.

6.3 Phase 3: Biannual Non-Urban Visual Assessments

Caltrans will implement the following ongoing future reassessments to ensure compliance with interim and final compliance milestones.

6.3.1 Full Capture Equivalence Assessments

Caltrans may elect to substitute LOS for OVTA at some or all locations for the biannual trash assessments as described in section 4.2 and Attachment D. The driving visual assessments of all moderate, high, and very high rated STGAs, that have been claimed as full capture equivalence, will be reassessed to ensure sustained compliance over time. Visual assessments will indicate if institutional controls are sufficiently addressing deviations in trash generation through the final compliance date. These visual assessments will be conducted biannually with at least 2 LOS or 1 OVTA scores. If Caltrans elects to substitute LOS for OVTA, Caltrans will notify the State Water Board of the locations to request State Water Board's concurrence.

6.3.2 Modified Driving Visual Trash Assessments

Caltrans will conduct driving LOS, or OVTA, visual trash assessments in Non-Urban areas as follows:

1. Determine the appropriate assessment intervals (i.e., every 10 - 25 miles) for visual assessments based on corridor characteristics such as centerline miles, historic annual litter production rates, and proximity to receiving waters. Based upon this information, Caltrans will initially propose the intervals and present to the Water Board's for review and, if necessary, revision; and
2. Determine changes to the trash generation ratings. Caltrans proposes that if it finds, on average, that more than one moderate trash generating location per mile over any interval, that interval would be considered an STGA. Similarly, if Caltrans finds, on average, more than one high or very high trash locations per 5 miles within an interval, the interval would be considered a high or very high STGA.

The methods above will facilitate a fiscally responsible approach for performing visual trash assessments in non-urban areas that have the same characteristics for long stretches, as opposed to the urban area variability that warrant assessments every 0.5 miles in both directions. Caltrans will provide training to appointed district staff to increase the accuracy of the ratings and reduce the risk of missing STGAs. This will include the use of the Trash Dashboard to flag areas with recurring work orders and increased litter removal.

Caltrans is targeting to complete this exercise by December 1, 2025.

6.3.3 Low Rated Area Assessments

Caltrans will perform assessments of low rated areas using the following tools to track deviations in trash generation over time:

1. **Trash Dashboard to monitor IMMS work order litter collection and expenditure data; and**
2. **Customer Service Request (CSR) data.**

The Trash Dashboard and CSR indicators will assist in informing Caltrans:

- **Where to focus trash collection resources to reduce trash discharges.**
- **Determining the actual amount of trash discharged**
- **Evaluate the spatial distribution and temporal changes in trash generation to evaluate the overall effectiveness of non-urban trash control programs.**
- **Determine if visual assessments are required to identify additional STGAs**

7.0 Maintenance Trash Dashboard Model

Caltrans will develop a Trash Dashboard Model to integrate quantitative maintenance data records to create trash generation visualizations from maintenance work orders that track litter production in relation to receiving waters, historically underserved communities, and environmentally sensitive areas.

Caltrans is taking a spatially explicit approach to identifying urban and non-urban ROW with respect to litter production thresholds. Caltrans will rely upon location-specific data from IMMS to help identify non-STGA areas and areas requiring OVTA or LOS visual assessment. The Trash Dashboard will not only interface with IMMS to identify STGAs, but also be used as a compliance tool to house STGA mapping, track System deployment, and full trash capture equivalent institutional controls (maintenance litter collection, vegetation control, and encampment prevention) that Caltrans will implement through its compliance actions. The Trash Dashboard will also be able to facilitate the management of data needed to optimize environmental outcomes from capital improvement projects.

The Trash Dashboard will be a powerful geospatial stormwater data management and reporting system purpose-built to aid Caltrans in automating non-urban area STGAs ratings, documenting implementation driven compliance visual assessments, memorializing inspections and cleanings, tracking litter collection work orders and trash collection volumes, and planning and managing stormwater assets to aid in annual reporting data needs.

Attachment B describes the scope of the Trash Dashboard Model development, which Caltrans is targeting to complete by March 31, 2024.

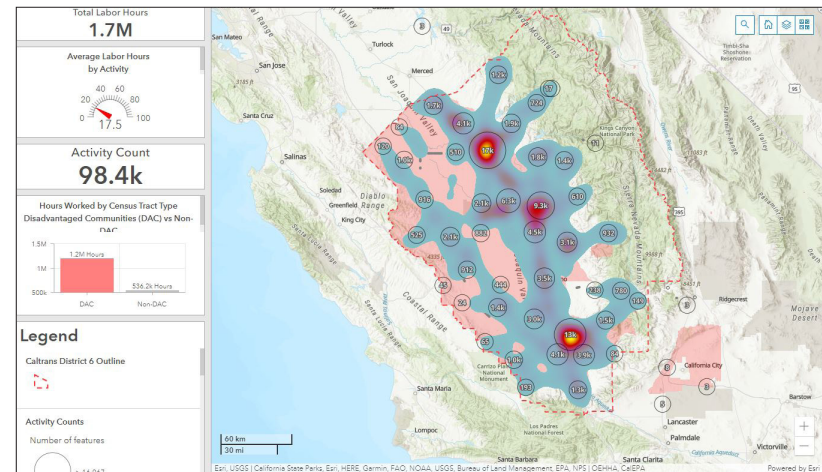

8.0 Other STGA Considerations

8.1 Adaptive Management

Caltrans adaptive approach will consist of three discrete phases of implementation. Phase I of the TAM will focus on specific strategies outlined herein. At the onset of each phase Caltrans will review opportunities and challenges and use available information and monitor progress toward established target completion dates.

At the end of each phase of assessment, Caltrans will evaluate its progress and adaptively manage its trash assessment strategies for the successive phase. This evaluation will demonstrate that Caltrans is fulfilling its Permit compliance obligations and effectively conducting all elements within the TAM. As data is collected and analyzed, Caltrans will adapt its compliance implementation strategies, as needed.

8.2 STGA Prioritization

Caltrans 12 districts responsible for compliance implementation efforts actively deploying compliance response actions and prioritizing the deployment of Systems, or full trash capture equivalent institutional controls to prohibit the discharge of trash to receiving surface waters of the State or the deposition of trash where it may be discharged into surface waters of the State. The priorities will be reevaluated as the STGA inventory is reconciled with the completion of assessments.

8.3 Special Event Considerations

District Maintenance managers travel highways, ramps, and collector systems weekly to inspect and observe overall conditions and to detect deficiencies, including the presence of trash. These inspections are an integral part of maintenance resource planning and deployment. Maintenance managers observe overall conditions to assure conformance with the established maintenance levels. Each Caltrans District manager will be directed to provide an assessment of widely understood trash generating areas such as informal trucker rest areas, vista points, routes to landfills, and special events.

8.4 Homeless Encampments

Caltrans' role with respect to encampments is to collaborate with partners to help connect people living along Caltrans' transportation network with critical services and shelter; coordinate cleaning of trash and debris from encampment sites; respond to emergencies at encampments to inspect for potential damage to Caltrans' infrastructure; and restore and protect the ROW after people have been relocated.

While Caltrans cannot relocate people into shelters or provide social services on its own, Caltrans is committed to assisting local partners in their efforts to assist people living on state property. The California Highway Patrol is the law enforcement agency responsible for addressing allegations of criminal activity on state property. Encampment removals without a coordinated relocation effort across state and local agencies will likely result in people returning to the same location, moving to adjacent city or county property, or being dispersed into the community, without resolving the core issues. All homeless encampment locations will be considered very high for the duration of time prior to cleanup. Caltrans field staff will report all instance of homeless encampment observed in its ROW.

Starting January 2023, an encampment count spreadsheet (Attachment E) and instructions will be provided to the encampment coordinator in each District to ensure statewide consistency, including quality assurance / control requirements.

Information such as city, county, route, postmile and direction of travel, the number of shelters in each camp site, the presence of RVs and/or vehicles that are used as a shelter/living space will be documented. Caltrans will remove encampments as soon as possible as allowed by law.



9.0 Full Trash Capture Equivalency

9.1 Overview

Caltrans is required to periodically visually assess its ROW to ensure it is controlling trash from STGAs. A subjective and qualitative visual assessment approach, somewhat similar to that used by Bay Area municipalities, is used to identify trash hot spots to both satisfy (1) the Region 2 CDO that required Caltrans to visually reassess the trash generation conditions in low trash generating areas of its ROW biannually and (2) the newly adopted Permit. These assessments are required to enable Caltrans to identify and ensure it is controlling trash from all its STGAs sufficient to meet CDO interim benchmarks and Attachment E Permit compliance deadlines.

Caltrans will continue its efforts, started in 2020, to develop a more scientifically sound, objective, and quantitative approach to demonstrate full trash capture equivalency. Below is a summary of what has been completed and what is currently planned.

9.2 Trash Discharge Studies

Caltrans is currently performing trash discharge studies to establish a maintenance activity performance standard by

identifying the type and frequency of maintenance activities that reduce trash discharges to the storm drain system at an equivalent level of a structural system. The maintenance activities and corresponding trash discharge volumes will be recorded and measured, with the performance standard translating to compliant trash discharge volumes (zero to five gallons per acre per year).

The Trash Discharge Studies will determine the volume of trash reaching storm drain conveyance systems measured in gallons/acre/year. The Study will include:

- **Collecting trash at baseline maintenance frequency;**
- **Measuring the volume of trash entering the storm drain inlets and captured by Systems;**
- **Substantiating full capture equivalency or low trash rating based - less than 5 gal/acre/year; and**
- **Identifying ROW locations where additional maintenance is necessary to accomplish full capture equivalency, or deployment of a full trash capture device is warranted.**



Catch basin inlet insert Systems will be temporarily installed to trap trash. Measurements of the trash will be taken over two years. The trash discharge rate will be measured for each of these sites and the results compared to the five gallons/acre/year BASMAA study threshold for a low trash generation rating. This trash discharge study could be used to further substantiate maintenance credits by documenting trash load reduction credit in Caltrans ROW that supports the attainment of trash reduction milestones. The findings of the study will be documented in a report scheduled to be completed annually through May 2025.

The primary objective of the study is to determine the baseline or enhanced trash collection maintenance that establishes full trash capture equivalency.

9.2.1 Urbanized ROW

A design study (**Attachment F**) has been developed to identify monitoring locations at 40 inlet locations within the jurisdiction of the San Francisco Bay and Los Angeles Water Boards, define maintenance actions and their frequency in those areas, determine the trash discharge volume entering the storm drain system that has the potential to threaten water quality, and consider adaptively managing the type and/or frequency of maintenance actions to adapt to varying trash conditions over time. The locations will not be in vegetated locations. Because the study is both labor and cost intensive, Caltrans is clustering the locations in two high traffic volume areas in the state for the purpose of efficiently utilizing resources.

Depending on the results of the study, additional actions may require adaptively improving the practice to identify the optimum level of effort that effectively reduce trash discharge to a full trash capture equivalency level for high and very high rated areas, or the combination of efforts, potentially including the combination of EMMs and/or structural controls.

9.2.2 Non- Urban ROW

Approximately 30 drainage inlet locations will be studied (including 10 high traffic locations between regulated MS4s) within the jurisdictions of the North Coast and San Francisco Water Boards, with at least 20 locations focused on Caltrans north region (Districts 1-3). The locations will be in non-urban ROW with a variety of annual per mile litter production rates. The locations will also be situated in areas with heightened environmental sensitivity that are in proximity, or directly discharge to receiving waters. If the results indicate that additional sites are warranted to draw conclusions, the study may be expanded to accommodate additional data points.

9.3 Early Results - Vegetation Control Study

Caltrans completed a three-year study between 2020 to 2023 at 14 drainage inlet locations situated in vegetated areas. Full trash capture equivalency was established by routinely measuring how much trash volume physically entered the drain inlets, as captured by Systems. The results showed that all 14 inlets received less than 5 gal/acre/year.

Table 9 below shows the discharge volumes for each year demonstrating that vegetation within Caltrans ROW has the potential to trap trash to the full trash capture equivalency standard. This conclusion is based on the measured trash discharge rates from all study areas, which all fall within the Low trash generation category with a rate of 0 to 5 gallons of trash generated per acre per year.

Table 9: Vegetation Control Study Discharge Results

Site	Trash Generation Rating	2020-21 Trash Discharge (gallons/acre/year)	2021-22 Trash Discharge (gallons/acre/year)	2022-23 Trash Discharge (gallons/acre/year)
1	Moderate	0.26	0.03	1.20
2	Moderate	0.28	0.15	0.45
3	Moderate	3.37	0.77	0.91
4	Moderate	1.20	1.08	0.76
5	Moderate	0.45	0.08	0.18
6	Moderate	0.70	0.01	0.04
7	Moderate	3.73	0.08	0.28
8	Moderate	0.00	0.00	0.00
9	Moderate	0.59	0.07	0.04
10	Moderate	0.24	0.16	0.03
11	High	0.00	0.00	0.00
12	High	0.17	0.35	No longer in service
13	High	0.01	0.06	0.99
14	High	0.0.34	0.19	0.18

Caltrans is committed to ensuring full trash capture equivalency for the control of trash by vegetation is verified, in consultation with State and Regional Board, through field verification, augmented engineering controls at discharge inlets when necessary, and maintenance trash removal frequency commitments, as outlined in Vegetation Control Study included as Attachment H.

Finally, a routine maintenance schedule will be identified to ensure that the visual nuisance of trash in Caltrans ROW, trapped by vegetation, is removed in annually prior to the wet season and prior to any mowing, to prevent the discharge of trash in excess of 5 gal/acre/year for trash 5mm or greater into the storm drain conveyance system.

9.3.4 Early Results – Trash Nets

As part of the trash discharge study, Caltrans recently measured trash volumes from five certified end-of-pipe trash net Systems to calculate associated gallons per acre per year of trash discharged. The purpose of this exercise was to obtain advance quantitative trash discharge from the above-average 2022-23 wet season. The findings from this initial measurement showed that trash discharge rates were all less than 5 gallons/acre/year at the measured locations, suggesting maintenance measures, even at the sites with very high or high STGA ratings, were effective at reducing trash discharges to full trash capture equivalency.

The full data summary from these volume measurements is presented in Table 10 below.



Table 10: Trash Net Discharge Volume

Trash Capture Device IMMS	Description	Trash Rating	1-Mile Average Annual Manual Litter Collection	Trash Net Installation	Trash Net Cleaned	Gallons Trash Captured	Drainage Area (Acres)	Capture (Gal/Acre/Year)
SWALA580-W039178	WB I-580 TO NB SR-13	Very High	188 CY	March 2022	March 2023	10	2.09	4.78
SWALA580-EO31689	EB I-580 @ 164th	Moderate / High	188 CY	March 2022	March 2023	1	4.61	0.25
SWALA580-W039880	WB I-580 @ MacArthur	Moderate	188 CY	March 2022	April 2023	3	6.2	0.48
SWALA880-S007278	SB 880 @ Mowry	Moderate	146 CY	2020	March 2023	0.25	10.7	0.02
SWALA880-S006312	SB 880 @ Stevenson	Moderate / High	146 CY	March 2022	April 2023	13.5	5.37	0.59

10.0 Interim Trash Reduction Milestones

Caltrans will be implementing Systems and submitting compliance credit acreage through any combination of other treatment controls, source control activities and/or institutional controls to meet trash reduction milestones.

The trash reduction milestones are established as the following:

1. By December 2, 2025, achieve full capture equivalency at 35 percent or more of the total STGAs identified.
2. By December 2, 2028, achieve full capture equivalency at 70 percent or more of the total STGAs identified.
3. By December 2, 2030, achieve full capture equivalency at 100 percent of the acres identified as STGAs.

Once the trash assessment is complete and the total inventory of STGAs established, Caltrans will be able to apply a quantitative number to each compliance benchmark. Each District will be asked to develop a work plan to outline the multi-pronged trash response actions and Caltrans District stormwater managers will monitor progress, including the programming and delivery of structural control projects as outlined in the forthcoming Statewide Trash Compliance Implementation Plan.

The above milestones may be subject to change, as Caltrans can submit its own trash reduction milestones for State Water Board Executive Director review and approval.

11.0 Baseline Trash Volume

Baseline trash loading rates are quantified on a volume per unit area basis and based on factors that significantly affect trash generation (e.g., traffic volumes, adjacent land use, adjacent economic profile, and rainfall) Default trash generation rates developed through the BASMAA regional collaborative project along with IMMS (cubic yards / mile & gallons / acre) will be explored for each Caltrans District.

11.1 Urban Area Loading

Baseline trash generation loading established by BAASMA for each trash rating (very high, high, and moderate) will be used to establish baseline loading in urban areas.

11.2 Non-Urban Area Loading

IMMS litter production data in cubic yards / mile have been evaluated for state routes with varying lane configuration scenarios and adjusted based on assumptions (qualifying trash, potential to enter inlets, and hydraulic connectivity) to establish a correlation to BAASMA trash loading for each rating (very high, high, and moderate).

Details on the initial trash loading can be found in Attachment G.

12.0 Annual Trash Reduction

Based on trash generation rates described in the previous sections, annual trash reduction (gal/acre) for Caltrans stormwater will be determined from the areas where full trash capture devices are installed along with full trash capture equivalent institutional controls.

12.1 Annual Report

The Permit requires that a Trash Annual Report is prepared by November 30th. The report will describe the implementation progress achieved during the previous fiscal year reporting period of July 1 through June 30. As a part of the Annual Report, Caltrans will perform an annual assessment of the amount of trash reduction achieved through implementation of Systems, other treatment controls, and institutional controls.

12.1.1 Full Trash Capture Devices

As full trash capture devices are rolled out, the associated trash reduction associated with the assigned trash rating(s) will be calculated and reported.

12.1.2 Full Trash Capture Equivalency

As full trash capture equivalent institutional controls are deployed and submitted for compliance, the associated trash reduction associated with the assigned trash rating(s) for those areas will be calculated and reported.

13.0 Trash Assessment Implementation Deliverables

This section outlines the deliverables from the implementation assessment plan and associated Permit requirements. This schedule of deliverables will help Caltrans and our stakeholders ensure timely action in the phased approach to statewide trash assessment efforts. Progress will be documented in the Trash Compliance Annual Report.

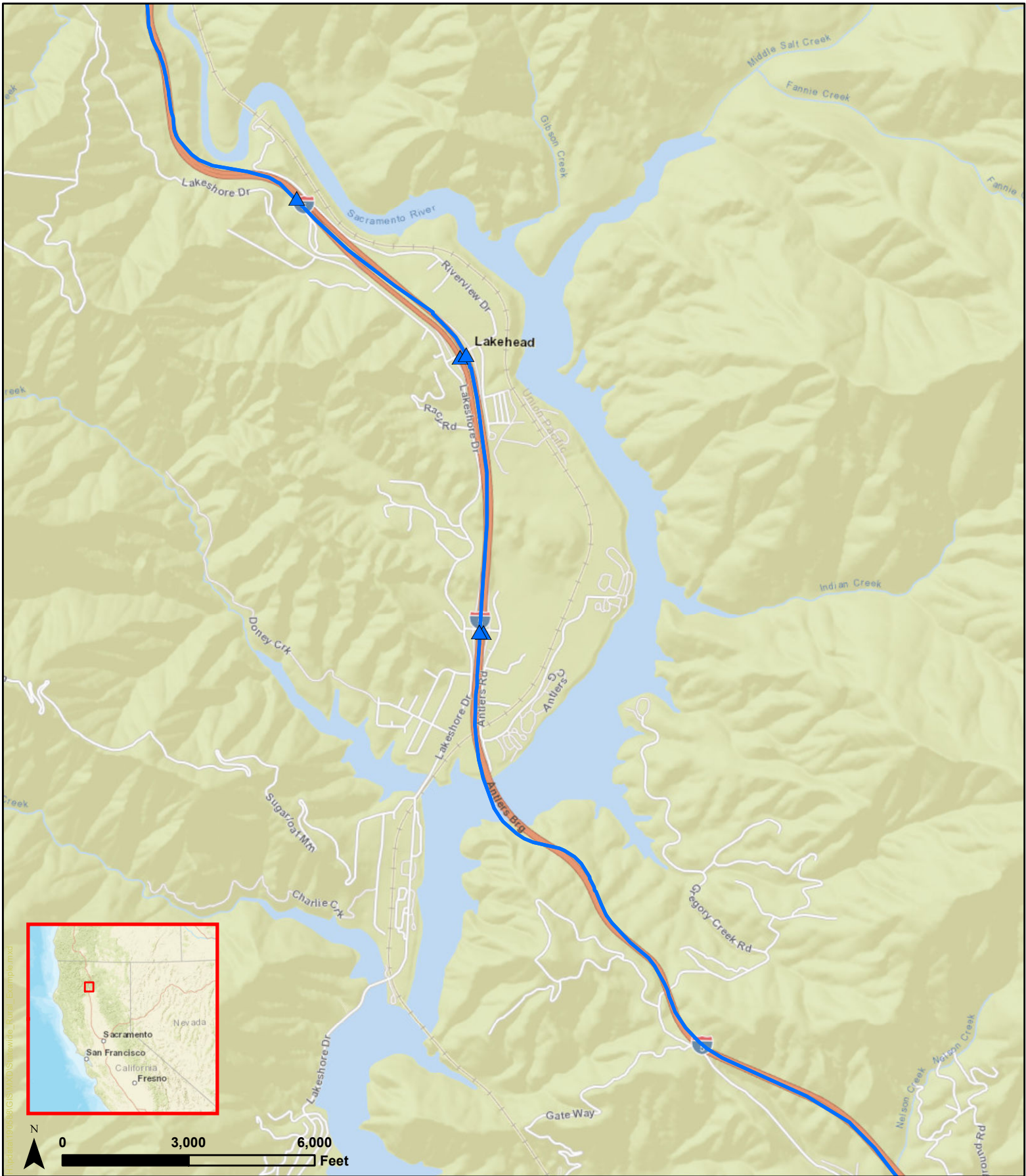

Table 11: Trash Assessment Deliverables

Attachment E Permit Reference	Plan Section	Action Description	Begin Date	End Date
E.9.3.b	4.0	Urban OVTA Assessment within MS4	December 1, 2023	June 30, 2024
E.9.2.b	2.4	Urban GIS Mapping of MS4 STGAs	January 1, 2024	July 31, 2024
E.9.3.a	6.0 7.0	Non-Urban Initial Maintenance Data Trash Dashboard assessment	September 1, 2023	March 31, 2024
E.9.2.b	2.4	GIS Mapping of initial Non-Urban STGAs	February 1, 2024	April 30, 2024
E.9.3.c	8.3	Homelessness Encampment Point in Time Count	January 6, 2023 (Annual Effort)	February 17, 2023 (Annual Effort)
E.9.3.d	4.2	Expanded LOS visual assessment program as an alternative to OVTA	January 1, 2024	October 30, 2025
E.9.2.c	8.3	Full Trash Capture Equivalency Trash Discharge Study – 40 Urban ROW Drainage Inlet Locations	March 1, 2023	July 31, 2025
E.9.3.d	8.4	Substitute for visual assessment Trash Discharge Study – 30 Non-urban ROW Drainage Inlet Locations	May 1, 2023	July 31, 2025
E.9.3.d	6.0 7.0	Non-Urban Final Maintenance Data Trash Dashboard – reconciled assessment	March 31, 2024	June 30, 2026
E9.4	9.0	Baseline Trash Assessment Volume	September 1, 2023	March 1, 2024

Attachment A:

Sample of Assessment and STGA Maps



Ramps

▲ Reassessment Area

Highways (North and East Direction)

— Reassessment Area

Highways (South and West Direction)

— Reassessment Area

Rural Highway Example

Reassessment Area

Lakehead, Shasta County / 40.89808, -122.38288



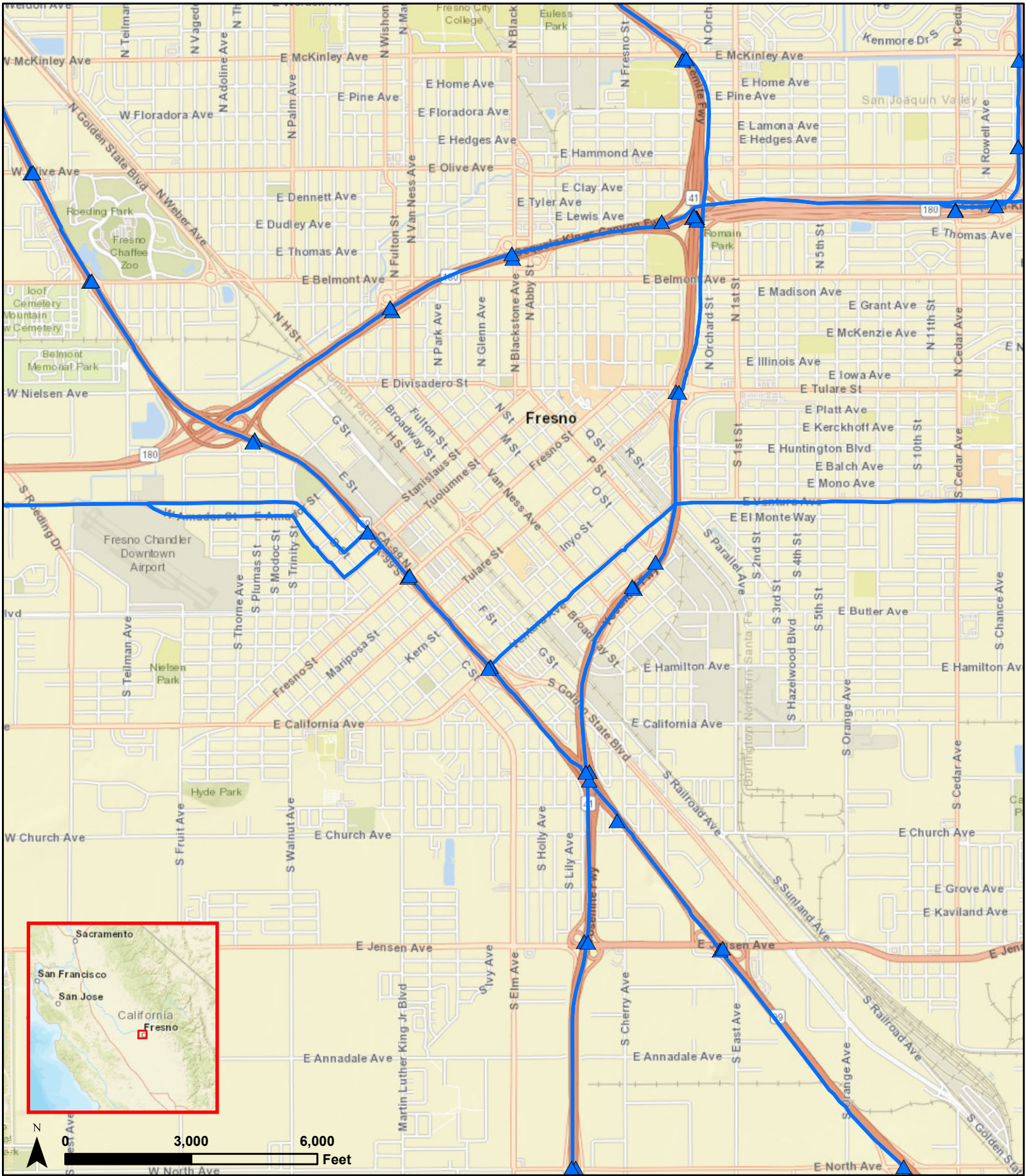

Urban Highway Example
Reassessment Area

- Ramps**
- ▲ Reassessment Ramp
- Highways (North and East Direction)**
- Reassessment Area
- Highways (South and West Direction)**
- Reassessment Area



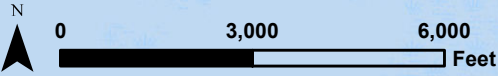
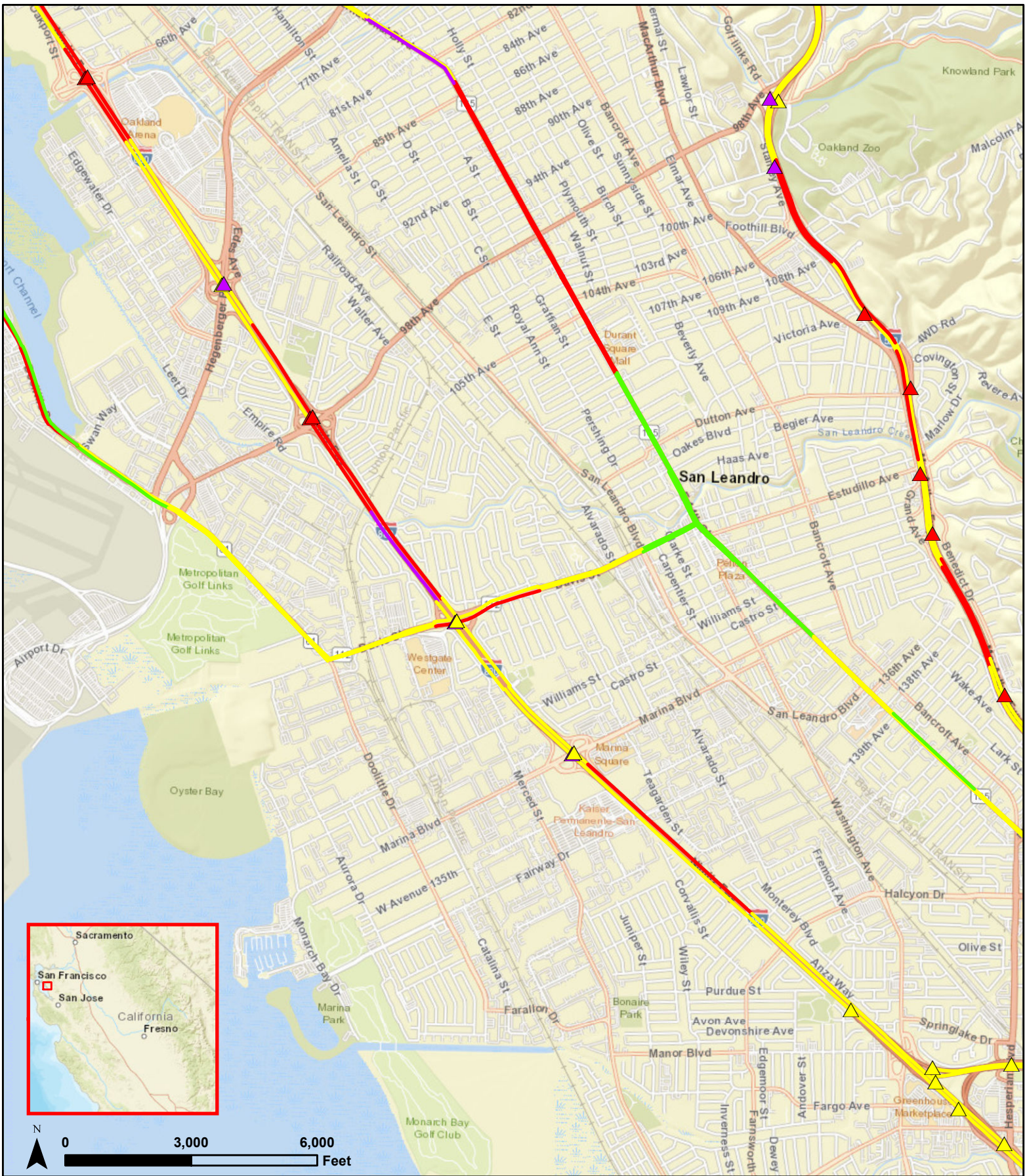

Ramps	Highways
Low	Low
Moderate	Moderate
High	High
Very High	Very High

Urban Highway Example

Assessed Area



Attachment B:

Trash Dashboard Portal Development Scope



PURPOSE

The Trash Provisions became effective on December 2, 2015 and prohibit the discharge of trash to receiving waters. Throughout the state, trash is typically generated on land and transported to surface waters through stormwater discharges. The Trash Provisions have been formalized into Attachment E Section E.9 requirements of the Caltrans National Pollutant Discharge Elimination System (NPDES) Statewide Stormwater Permit (Order) adopted on June 22, 2022. The Order includes the implementation requirements for the Trash Total Maximum Daily Loads in District 7. Caltrans is also under a Trash Discharge Cease and Desist Order in District 4. To address statewide trash assessment and compliance obligations, Caltrans has developed an assessment methodology known as the 2023 Trash Assessment Implementation Plan.

There are several challenges surrounding Trash assessment and compliance crediting from response actions and the associated mapping. Caltrans consultant, with oversight support from District 6 GIS experts, will develop a Trash Dashboard Portal, mobile data collector, and associated inventory web mapping to facilitate the tracking and annual reporting of compliance progress; providing a tool for cross-functional response teams Statewide.

EXPERIENCE

In addition to Caltrans experience with Trash assessment mapping, the Design team shall also demonstrate competency utilizing the following technologies:

- ArcGIS Online and Portal
- ArcGIS Survey123 and Field Maps
- Integrated Maintenance Management System (IMMS)
- Microsoft SQL Server
- On-land Visual Trash Assessment (OVTA)

PROPOSED SCOPE OF WORK

Caltrans consultant, with District 6 oversight, shall provide professional GIS services to assist the Program in developing a trash assessment visualization tool that integrates IMMS, Municipal Separate Stormwater System boundaries, receiving water bodies, and Environmentally Sensitive Areas to map Significant Trash Generating Areas (STGAs) (as determined by OVTA). The tool will serve to identify rural areas with litter production less than 30 CY / mile / year that will be designated as low trash generation, identify rural areas with litter production greater than 30 CY / mile / year that will require modified OVTA, provide a repository for compliance actions through a mobile application Maintenance managers can utilize in response to enhanced maintenance, and extract annual compliance actions for regulatory reporting purposes.

The Stormwater Program will provide the associated documentation and resources. The GIS Design Team will perform coordination with other Caltrans divisions to procure additional resources as needed (e.g., ArcGIS Online or Portal accounts) to perform work including with the Division of Maintenance Statewide IMMS lead to obtain IMMS litter production data from FY 20, FY 21, FY 22, and in real time moving forward .

Development of the Trash Assessment and Compliance Dashboard will occur in phases as information is needed and/or obtained.

Task – GIS Database Architecture and Mobile Collection Plan

- Provide a website with aesthetic visuals and with mapping, filtering, editing and downloading functionality
- Develop the high-GIS accuracy Survey123 forms with compliance logic in accordance with the Design Information Bulletin 82 (DIB82) and the Caltrans Standard Plans
- Develop a centralized GIS repository in SQL Server for all information.

Deliverable(s):

- 1.1 – Visualization Platform
- 1.2 – Mobile Application
- 1.3 – Repository Website

Attachment C:

Caltrans Driving OVTA Protocol



Driving On-Land Visual Trash Assessment Protocol

California Department of Transportation
Division of Environmental Analysis
1120 N Street
Sacramento, CA 95814
<http://www.dot.ca.gov/hq/env/stormwater/>

CTSW-RT-17-316.19.1

Last Updated: November 2023

For individuals with sensory disabilities, this document is available in alternate formats upon request.

Please call or write to:

Stormwater Liaison, Caltrans Division of Environmental Analysis, MS-27

P.O. Box 942874, Sacramento, CA 94274 0001

(916) 653 8896 Voice, or dial 711 to use a relay service.

Table of Contents

1. Introduction	1
2. Assessment Preparation and Planning	3
2.1 Assessment Personnel	3
2.2 Equipment and Supplies	3
2.3 Assessment Area	3
2.4 Field Maps	3
2.5 Timing of Assessments	4
2.6 Safety	4
3. Trash Generation Category Definitions	6
3.1 Low Trash Generation Category – Not Littered	7
3.2 Moderate Trash Generation Category – Slightly Littered	7
3.3 High Trash Generation Category – Littered	8
3.4 Very High Trash Generation Category – Very Littered	8
4. Assessment Protocol	9
4.1 Safety Reminder	9
4.2 Preparation and Video Camera Set-up	9
4.3 Visual Assessments	10
4.4 Photographic and Video Documentation	10
4.5 Ramp Assessments	10
5. Data Upload and QAQC	11

Figures

Figure 2: Low Trash Generation Category Examples	7
Figure 3: Moderate Trash Generation Category Examples	7
Figure 4: High Trash Generation Category Examples	8
Figure 5: Very High Trash Generation Category Examples	8
Figure 6: Proper Video Camera Window-Mount Setup	9

Tables

Table 1: Trash Generation Categories	6
--------------------------------------	---

This page was intentionally left blank.

1. Introduction

The purpose of the Driving On-land Visual Trash Assessment (OVTA) Protocol is to provide a repeatable methodology for obtaining qualitative estimates of trash discharges from Caltrans right-of-way (ROW) to storm water conveyance systems. The protocol is designed as a driving methodology to assess highways and ramps that cannot be walked or are unsafe to walk.

“Trash generation” is a term used to describe the amount, or volume, of trash that enters storm drain inlets and is believed to be discharged from stormwater conveyance systems to receiving water bodies¹. The protocol serves the following two purposes:

1. **Confirmation or Establishment of Baseline Trash Generation** – to provide a line of evidence to confirm or to designate trash generation rate categories assigned to specific land areas, and;
2. **Assessing Changes in On-land Trash Generation** – to provide a qualitative tool to assist in evaluating changes in the level of on-land trash that could be transported to a stormwater conveyance system.

In this methodology, the definition of trash or litter is generally consistent with the definition included in California Code Section 68055.1(g)². Trash is defined as all improperly discarded waste material, including, but not limited to, convenience food, beverage, and other product packages, or containers constructed of steel, aluminum, glass, paper, plastic, and other natural and synthetic materials, thrown or deposited on the lands and in the waters of the state, but not including the properly discarded waste of the primary processing of agriculture, mining, logging, sawmilling, or manufacturing.

Trash does not include sediment and vegetation. For this protocol, mattresses, shopping carts, furniture, appliances, and all other illegally dumped items not capable of fitting in a storm drain inlet opening are also excluded from the definition of trash.

¹ Tracking California’s Trash On-land Visual Trash Assessment Final Report:
<http://basmaa.org/DesktopModules/EasyDNNNews/DocumentDownload.ashx?portalid=0&moduleid=524&articleid=21&documentid=70>

² California Legislative Information - TITLE 7.9. RECYCLING, RESOURCE RECOVERY, AND LITTER PREVENTION
https://leginfo.legislature.ca.gov/faces/codes_displayText.xhtml?lawCode=GOV&division=&title=7.9.&part=&chapter=&article=

This page was intentionally left blank.

2. Assessment Preparation and Planning

2.1 Assessment Personnel

This methodology requires at least two field personnel: one driver, and one passenger performing the visual assessments and managing a video camera. An additional person in the office should be designated as a point-of-contact with cell phone numbers of all field personnel and their planned schedule (i.e., location and time). First-time assessors shall review this protocol and discuss the process with an experienced assessor prior to performing assessments. Whenever possible, an experienced assessor will train first-time assessors in the field to ensure the protocol is executed correctly.

2.2 Equipment and Supplies

The following equipment is needed to properly apply the protocol:

- Copy of associated Caltrans Task Order
- Field vehicle;
- Company logo (magnetic placard);
- Digital video camera with built-in GPS capabilities, such as the currently used Nikon D5300 digital SLR, used in “sport mode” to achieve fast shutter speeds that minimize blurring when driving at speed.
- Backup video camera battery;
- Battery charger for car;
- A car video camera window mount;
- Mobile dongle or camera remote with GPS-assisted triggering or distance-lapse photography;
- Cell phone to connect to mobile dongle (if needed);
- Safety/hazard warning light to mount on top of car;
- Permanent marker;
- Clipboard;
- Field maps of the assessment area; and
- Laptop computer for field data QC.

2.3 Assessment Area

When conducting assessments on a highway segment or ramp, the width of the assessment area extends from the center line of the road (or middle of the median) to the edge of the right-of-way. It includes the area that could reach the stormwater drainage system, including but not limited to the median, highway, shoulder, ramps, and vegetated areas³. The assessment’s focus comprises any trash in visible areas that could theoretically reach the stormwater drainage system. If there are obstructions, such as a fence, that would prevent trash from moving to the stormwater drainage system, then the area should not be included as part of the assessment⁴.

2.4 Field Maps

Field maps of the assessment areas must be developed to document assessment ratings. The maps must clearly display the ramp locations and 0.5-mile highway segments in each assessment area to help orient

⁴ Tracking California’s Trash On-land Visual Trash Assessment Final Report:
https://basmaa.org/wp-content/uploads/2021/01/tct-ovta-report_final-with-appendices.pdf

assessors in the field. Hard-copy maps shall be printed for each area to be assessed, and assessment results recorded onto the maps with permanent ink.

2.5 Timing of Assessments

Assessments can be performed to establish baseline trash generation rates and to evaluate the progress of trash reduction efforts⁵.

When using the protocol to assess baseline trash generation, the timing of the assessment should be selected carefully to account for trash cleanup events (street sweeping, trash cleanups, etc.). Baseline assessments should be conducted right before cleanup events (to the extent practicable) to depict the maximum trash generation for the specific area.

When using the protocol to assess progress of trash reduction efforts, assessments should be performed at the half-way point between sweeping events (such as street sweeping, trash cleanups, etc.) to depict the average trash generation. Progress can only be assessed for segments that already have established baseline generation rates.

Additionally, to reduce the influence of recent rainfall in designating trash generation rates, assessments should not be conducted after a significant rainfall event. For this protocol, a significant rainfall event is defined as at least 0.5 inches of rain in a 24-hour period occurring within a 48-hour period before the assessment. A rainfall event has the potential to wash away highway trash into storm drains, which may lower levels of trash for specific areas of interest.

2.6 Safety

Safety is the top priority when performing assessments. A safety tailgate meeting shall be held with all assessment team members present prior to performing assessments. The safety tailgate shall cover:

- **Safe driving** – Drivers are responsible for navigating the assessment team to and from assessment areas safely in accordance with the Caltrans Code of Safe Operating Practices. Prior to performing assessments, drivers should familiarize themselves with the planned assessment route, which will assist with the safe navigation of on/off ramps, turns, and assessment areas. Slow speed assessments can be accomplished during rush hour traffic or through a coordinated moving lane closure. Lane closures require a traffic control plan as authorized by the Deputy District Director of Traffic Operations in accordance with procedures outlined in Chapter 8, Section 8.11.01 of the Caltrans Maintenance Manual and the Federal Highway Administration Manual on Uniform Traffic Control Devices. California Highway Patrol should also be contacted for Maintenance Zone Enhanced Enforcement Program support. Flashing amber lights may only be needed when driving below prevailing speeds otherwise there is no need or hazard to warn motorists. If amber rotators are used when not needed, they could lose effectiveness.
- **No parking or exiting the vehicle in ROW** – Parking or stopping the vehicle in the ROW is strictly prohibited. Drivers shall safely navigate the vehicle to a designated parking area prior to stopping the vehicle and allowing team members to exit.
- **Equipment check** – A safety/hazard warning light shall be installed on the roof of assessment vehicles and be turned on whenever assessments are actively being performed. A company logo (magnetic placard) must be displayed on all field vehicles when performing assessments. At least 2 team members shall independently verify that the logo/placard and safety/hazard light are properly secured to the vehicle prior to beginning assessments.

⁵ SWRCB Guidance, Monitoring Considerations for the Trash Amendments: https://www.waterboards.ca.gov/water_issues/programs/stormwater/docs/trash_implementation/monit_considerations_trash_amend_July2017v2.pdf

- **Office contact** – The assessment team shall designate an office point of contact for each day of assessments. The team shall communicate assessment start and finish times, and rely on the office contact for logistical and troubleshooting support if needed.

3. Trash Generation Category Definitions

This assessment protocol is based on visual observations of the level of trash in a defined assessment area. There are four primary trash generation categories (Low, Moderate, High and Very High) that an assessment area may be assigned based on the visual assessment.

Table 1: Trash Generation Categories

Trash Generation Category	Definition
Low – Not Littered	<ul style="list-style-type: none"> • Effectively no trash is observed in the assessment area. • Approximately less than one piece per two car lengths on average. • There may be some small pieces in the area, but they are not obvious at first glance. • One individual could easily clean up all trash observed in a very short timeframe.
Moderate – Slightly Littered	<ul style="list-style-type: none"> • Predominantly free of trash except for a few littered areas. • On average, one piece per two car lengths. • The trash could be collected by one or two individuals in a short period of time.
High – Littered	<ul style="list-style-type: none"> • Predominantly littered except for a few clean areas. • Trash is widely/evenly distributed and/or small accumulations are visible. • At least two or three pieces per car length on average. • It would take a more organized effort to remove all trash from the area.
Very High – Very Littered	<ul style="list-style-type: none"> • Trash is continuously seen throughout the assessment area. • Large piles and a strong impression of lack of concern for litter in the area. • There is often significant litter. • It would take a large number of people during an organized effort to remove all trash from the area.

Important Note: Because the protocol is intended to assess the level of trash observed on-land that can reasonably be transported to the stormwater conveyance system, only trash that appears to be mobile should be included in the assessment. Large items such as furniture, tires, and appliances should not impact assessment ratings. Additionally, graffiti on highways, walls, buildings, or landscaping in disrepair will not affect the assessment ratings.

3.1 Low Trash Generation Category – Not Littered

The following figure show examples of low trash levels. Effectively no trash is observed in the assessment area.

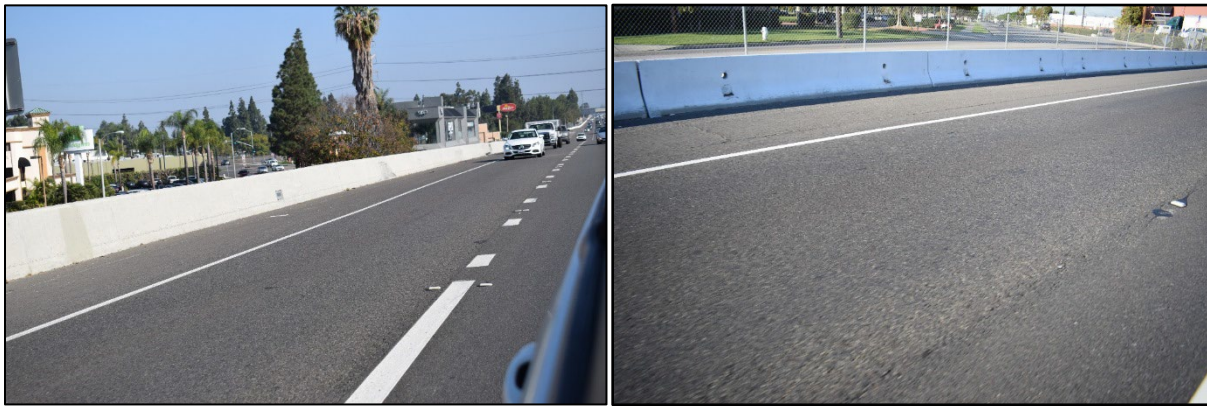

Figure 1: Low Trash Generation Category Examples

3.2 Moderate Trash Generation Category – Slightly Littered

The following figure show examples of moderate trash levels. The assessment area is predominantly free of trash except for a few littered areas.



Figure 2: Moderate Trash Generation Category Examples

3.3 High Trash Generation Category – Littered

The following figure show examples of high trash levels. The assessment area is predominantly littered except for a few clean areas.



Figure 3: High Trash Generation Category Examples

3.4 Very High Trash Generation Category – Very Littered

The following figure show examples of very high trash levels. Trash is continuously seen throughout the assessment area.



Figure 4: Very High Trash Generation Category Examples

4. Assessment Protocol

4.1 Safety Reminder

Safety is the top priority when performing assessments. Prior to the start of the visual assessment, ensure a company logo (magnetic placard) is clearly displayed on the side door panel of the field vehicle. Place the safety/hazard warning light on top of your car and test its function. Flashing amber lights may only be needed when driving below prevailing speeds otherwise there is no need or hazard to warn motorists. If amber rotators are used when not needed, they could lose effectiveness.

4.2 Preparation and Video Camera Set-up

Field maps prepared in the office should clearly delineate 0.5-mile highway segments and ramps. The delineation will help field assessors easily identify the segment or ramp they are rating while driving the highway.

Prior to beginning an assessment, the video camera must be mounted to a window on the right and left sides of the car with a video camera window mount. The mount assists with capturing quality photographs and video with a consistent field of view. The video camera should be angled to capture the maximum amount of ROW while minimizing features that are not relevant to the assessment (e.g. side of field vehicle, sky, etc.). The optimal video camera position is angled approximately 120 degrees (in the horizontal plane) from the direction of travel and 30 degrees down (from the horizontal plane).

The following figure shows an example of the proper video camera set-up.



Figure 5: Proper Video Camera Window-Mount Setup

Once the video camera is correctly mounted, the mobile dongle or camera remote shall be set to take photos every 0.1 miles and to provide continuous recording. Proper function of the distance-lapse or remote photo triggers should be tested prior to beginning an assessment.

For ramp assessments, the video camera operator shall unmount the camera from the window and manually “point and shoot” to capture two to five representative photos of ramp trash generation rates.

4.3 Visual Assessments

In order to improve the accuracy of visual assessments, Caltrans will maximize efforts to perform OVTAs at speeds of 25 MPH or less for each ½ mile segment. The average speed for OVTAs will be recorded for each ½ mile segment.

Slow speed OVTAs can be accomplished either:

1. During rush hour traffic; or
2. Moving lane closure.

When targeting rush hour to achieve the slow speed for assessments, there may be limited circumstances where the flow of traffic may result in a speed in excess of 25 MPH. In these situations, assessors will note the segment and speed and rely on the video footage that will be played back at a slow speed equivalent to a driving speed of 25 MPH or less. The assessor will then assign the trash rating for the segment(s) based on the subsequent video review.

When conducting assessments on a highway segment or ramp, the width of the assessment area extends from the center line of the road (or middle of the median) to the edge of the ROW. It includes the area that could reach the stormwater drainage system, including but not limited to the median, highway, shoulder, ramps, and vegetated areas. The assessment’s focus comprises any trash in visible areas that could theoretically reach the stormwater drainage system. If there are obstructions, such as a fence, that would prevent trash from moving to the stormwater drainage system, then the area should not be included as part of the assessment.

A visual assessment begins with the driver safely navigating the vehicle to the beginning of an assessment area. Once in the assessment area, the assessor/video camera operator shall initiate the photo / video collection process and begin documenting the observed trash generation categories associated with each ramp or 0.5-mile highway segment on the field maps using a permanent marker.

4.4 Photographic and Video Documentation

The assessing passenger will also act as the video camera operator and ensure photos and video footage are properly collected for each ramp and highway assessment area. Photos and videos are collected to document the completion of an assessment and may be used to assign trash generation ratings for segments that exceeded 25 MPH.

4.5 Ramp Assessments

The paper maps should also have ramps displayed that do not show any baseline rates or previously assessed trash generation categories. Ramps will be assessed through visual observations by the field assessor and trash generation categories will be marked on the paper maps. Field assessors will assign a trash category to both the on-and off-ramps and average the two scores for an overall ramp score. The video camera operator will do their best to capture a few point-and-shoot photos of the ramps and take continuous video. The photos and video will support field observations but will not be used to assign ratings to ramps.

5. Data Upload and QAQC

After the completion of each assessment, photos and video should be checked prior to leaving the assessment area to ensure the photo and video collection process was completed properly (i.e. photos are geotagged; distance-lapse function was performing correctly, continuous video, etc.).

Field maps, photos, and video should be digitized and saved to a database storage network within 2 days of completing an assessment to ensure valuable assessment information is not lost.

Attachment D:

Level of Service Alternative Assessment



LEVEL OF SERVICE (LOS) ALTERNATIVE VISUAL ASSESSMENT

1. Executive Summary

This document describes the Caltrans LOS program procedures proposed as an alternative visual assessment method that will be used:

- For statewide biannual visual assessments required for low and moderate rated trash generation areas.
- To substantiate trash compliance from litter collection in trash hot spots.
- To maximize regulatory compliance within budgetary constraints.
- To provide legislative reporting transparency and accountability in meeting measurable objectives and performance outcomes associated with Governor Newsom's Clean CA initiative.
- To avoid instituting two distinct trash assessment programs, associated training, and effort to implement.

Caltrans Headquarters requires District maintenance supervisors use LOS to conduct and document trash assessments by assigning scores to each segment based on the density of litter LOS scores can be translated to OVTA ratings to satisfy the Permit requirements. Both the Permit and CDO requires Caltrans to demonstrate full capture equivalency at all significant trash generating areas (STGAS) where certified full capture systems are not installed.

As an alternative to OVTAs, Caltrans is considering expanding the LOS program, currently implemented in its high traffic urban ROW, to its non-urban ROW to demonstrate sustained full trash capture equivalence at interim and final benchmarks. If Caltrans finds it to be infeasible to expand the LOS program, then OVTAs will be implemented.

2. Regulatory / Legislative Background

In response to the Governor Newsom's July 2021 Clean CA Order to minimize the presence of trash within Caltrans ROW, Caltrans developed the LOS program to provide trash generation ratings based upon quarterly visual assessment of highway segments, and the necessary maintenance resources necessary to remove the trash from the highway segments for each rating. Substantial resources were invested in developing LOS protocols and to train District maintenance supervisory staff in implementing the LOS protocols.

To comply with both the CDO and Permit, Caltrans has initiated a study to evaluate the effectiveness of Caltrans maintenance LOS effort in preventing the



discharge of trash to storm drain infrastructure on paved areas. Working with District maintenance managers, Caltrans Headquarters will:

- Document the trash profile characteristics from maintenance litter removal activities to determine what proportion of trash has the potential to be transported by storm events and fit between 1 and 3/8" storm drain grate inlet openings;
- Install certified full capture systems at 40 urban locations in the San Francisco and Los Angeles metropolitan areas along with 30 non-urban locations in northern California to measure the amount of trash trapped by the certified full capture system starting in 2023;
- Select locations for the study in coordination with the San Francisco and Los Angeles Regional Boards as well as the State Water Board. Attachment F provides the details of this study; and
- Determine a standard maintenance frequency to be conducted at all locations.

In theory, if the amount of trash trapped by the certified full capture systems is less than 5 gallons/acre/year at each inlet, full capture equivalence would be demonstrated. 5 gallons/acre/year represents the high point of what is considered "low" trash generation established by the OVTA. For example, if full capture equivalence is demonstrated by the study and LOS scores, certified full capture systems are not required to be installed that are similar to those selected for the study as long as maintenance is continued as implemented during the study.

Full trash discharge study details are provided in Attachments F and G.

3. Background

Caltrans currently requires District maintenance supervisors to:

- Conduct and document LOS assessments at 2,547 highly trafficked one-mile segments of highway statewide on a quarterly basis. LOS assessments are conducted prior to comprehensive litter removal maintenance;
- Measure, document, and report the volume of litter removed for each segment; and
- Assign scores to each segment based on the density of litter on the roadsides at the time of assessment and prior to any comprehensive litter removal. LOS scores range from zero to 100, with 100 being the best. These numeric ratings are translated to maintenance need scores ranging from



0, 1 and 2. As discussed below, LOS scores can be translated to OVTA ratings.

The data from the above reports establishes whether the Division of Maintenance is adequately maintaining the State Highway System according to the Clean CA Order. Currently, LOS assessments are conducted in urban ROW with high Average Daily Traffic (ADT). The selected segments only include Significant Trash Generating Areas (SGTA) and segments with high ADT that have not been identified as STGAs.

Caltrans LOS litter assessments provide:

- Legislative reporting transparency and accountability in meeting measurable objectives and performance outcomes associated with Governor Newsom's Clean CA initiative;
- Monitoring data that supports Caltrans to adaptively manage maintenance resources and efforts to collect litter; and
- Monitoring data that supports regulatory compliance.

LOS assessment has resulted in increased litter removal maintenance efforts which reduce the volume of trash that can be discharged.

4. Definition of LOS Trash Assessments

LOS trash assessments are defined as follows:

1. A maintenance performance evaluation tool designed to measure existing trash conditions against established standards.
2. A measure of whether Caltrans District maintenance staff is meeting the maintenance litter regeneration demands to control trash in each district.
3. Litter LOS assessments are conducted quarterly and represent a snapshot of how well the State Highway System is maintained at the time the evaluations were conducted.

5. Correlating Maintenance Effort

Caltrans Headquarters requires the Division of Maintenance to remove litter, debris, and sediment to help maintain traffic safety (for both motorized and non-motorized travelers and workers), protect water quality, maintain adequate drainage, and provide an attractive ROW for travelers and local communities.

Caltrans Integrated Maintenance Management System (IMMS) is a database used to record and manage maintenance work. IMMS, used as an asset



management tool, allows supervisors and managers to track effort across the various litter collection activities. The data can be used to determine trends across STGAs, such as known areas with consistent regeneration that require heightened attention. IMMS allows Caltrans to track litter collection expenditures and production through work orders for the various maintenance measures activities that contribute toward trash discharge compliance objectives.

Caltrans Headquarters requires each District maintenance supervisor to constantly monitor their areas of responsibility to detect and report increased maintenance resource needs. This includes periodic inspections of the ROW no less than quarterly. The following litter collection activities are utilized by District maintenance managers to meet stormwater regulatory mandates and address public complaints submitted by the public through the customer service request website:

1. Comprehensive Litter Collection (scheduled crews for entire corridors)
2. Freeway Litter Sweeping (Mechanized sweepers scheduled for entire corridors)
3. Litter Incident Response (continuous corridor attention to known regeneration areas and / or public service requests)
4. Encampment Related Litter Collection and Removal
5. Adopt-A-Highway Volunteer Litter Collection

Table 2 Includes the minimum frequency of comprehensive maintenance litter collection activities by trash rating. Items 4 and 5 are not included in Table 2 because the frequency and locations vary.

Table 2: Districtwide Maintenance Frequency (Average # of Work Orders / Mile / Year)

OVTA Rating	Litter Collection Frequency (A) (B)	Freeway Sweeping Frequency (C)	LOS Assessment Frequency (D)
Low	1+	1+-	1+-
Moderate	2+	2+	4+
High	4+	4+	4+
Very High	4+	4+	4+



Notes:

- A. Litter collection is only conducted in areas that can be accessed safely.
- B. District maintenance strike teams are deployed to remove trash when incidences of illegal dumping and/or large objects are reported from within and around the ROW.
- C. Freeway sweeping does not occur in hard to access areas of the ROW. District maintenance crews remove trash caught in Metal Beam Guard Rail Posts. Freeway sweeping frequency can be impacted in some areas due to staff safety and impact to the traveling public due to lane closures.
- D. Conducted quarterly independently of scheduled litter collection.

Table 3 includes the litter collection ranges for each OVTA trash rating as determined from D4 CDO control sites. This data is presented in Attachment G.

Table 3: Litter Collection (Cubic Yards/Mile/Year) For Each OVTA Rating

OVTA Rating	Approximate OVTA Gallons/acre/year	IMMS Litter Production CY/Mile/Year
Low	0-5	0 CY – 30 CY
Moderate	5-10	30 CY – 80 CY
High	10-50	80 CY – 180 CY
Very High	50+	> 180 CY

Please note that litter collection frequency and timing is contingent upon:

- 1. Temporary redirection of resources to respond to emergencies such as natural disasters, severe weather, and man-made destruction affecting the ROW.
- 2. Appropriation of resources by the Legislature and State Budget Act authority.

6. Justification For CDO Trash Capture Credits

Caltrans seeks to maximize its regulatory compliance activities within its budgetary constraints and Governor/legislative direction. To that end, Caltrans is using both OVTA to identify STGAs and the LOS trash assessments for on-going monitoring. Both are effective in complying with regulatory requirements.

In the 2,547 highly trafficked one-mile segments of highways, LOS assessments and litter removal are performed quarterly which provides more data than OVTAs. Use of the OVTAs is primarily reserved for designating STGAS in urban ROW. For urban ROW, LOS evaluates 1-mile segments and assigns ratings based on trash within 1/10-mile sections, which is comparable to the 0.5-mile OVTA frequency.



Therefore, Caltrans is using LOS in lieu of OVTA's to demonstrate progress toward full capture equivalency and other regulatory trash obligations.

Caltrans will only request full capture equivalency compliance credits when OVTA's, LOS, and/or discharge studies (vegetative and on-pavement) substantiate full capture equivalency. Caltrans will continue to work closely with State and Regional Board staff to provide transparency in maintenance litter collection operations, LOS procedures, and establishing objectives of the trash discharge studies.

7. OVTA – LOS Visual Assessment Comparison Crosswalk

Caltrans believes that LOS trash assessment scores are comparable to OVTA trash assessment scores. Table 4 includes a comparison of LOS and OVTA trash assessment scoring.



Table 4: OVTA – LOS Visual Assessment Comparison Crosswalk

BASMAA On-Land Visual Trash Assessment (OVTA)		Caltrans Clean California Level of Service (LOS)		
Trash Level	OVTA Definition	Trash Level	LOS Rating	LOS Definition
A. Not Littered (Low)	<ul style="list-style-type: none"> Effectively no trash is in the assessment area. There may be some trash in the area, but it is not obvious at first glance. One individual could clean up all the trash observed while walking at normal pace. No additional trash reduction measures are needed in the assessment area. 	Need 0 Need 1	<ul style="list-style-type: none"> 76-100 75-100 	<ul style="list-style-type: none"> Effectively No Trash present 0 or 1 localized instance of some trash (not more than a few pieces) within 1 mile (A localized instance is any location within 1/10 mile segment of 1 mile of assessment where trash is seen in that 1/10 mile of segment). Trash can be easily removed by an individual at a normal walking pace.
B. Slightly Littered (Moderate)	<ul style="list-style-type: none"> Predominantly free of trash, except for a few littered areas. Some trash is noticeable at first glance. The trash observed could be collected by one or two individuals, but would require walking at a slower than normal pace. Additional trash reduction measures are needed in the assessment area. 	Need 2	<ul style="list-style-type: none"> 50 - 74 	<ul style="list-style-type: none"> 2-3 localized instances of some trash and/or 1 localized instance of heavy trash within 1 mile. Heavy trash is a segment where trash is widely/evenly distributed. 1-2 staff needed to clean up the trash that may require a slower pace. Additional trash reduction measures may be required
C. Littered (High)	<ul style="list-style-type: none"> Predominantly littered, except for a few clean areas. Trash is widely/evenly distributed and/or small accumulations are noticeable on the streets and sidewalks. It would take multiple people to remove all trash from the area, frequently requiring individuals to stop walking to remove the trash. Roughly 4 times as much trash as a “B” level. 	Need 2	<ul style="list-style-type: none"> 26-49 	<ul style="list-style-type: none"> 2-5 localized instances of heavy trash within 1 mile. No more than 2 instances of piles of trash (a pile of trash fills an entire bag or more). Multiple staff needed to clean up the trash. Additional trash reduction measures may be required
D. Very Littered (Very High)	<ul style="list-style-type: none"> Trash is continuously seen throughout the assessment area and there is a strong impression of lack of concern for litter. Large piles of trash may be observed. 	Need 2	<ul style="list-style-type: none"> 0-25 	<ul style="list-style-type: none"> Greater than 6 or more localized instances of heavy trash within 1 mile or 3 or more instances of piles of trash within all segments Multiple staff needed to clean up the trash.



STORMWATER & CLEAN CALIFORNIA
Statewide Stormwater Permit

September 2023



	<ul style="list-style-type: none">• It would take a large number of people during an organized effort to remove all trash from the area, consistently requiring individuals to stop to remove the trash.• Roughly 3 times as much trash as a "C" level.			<ul style="list-style-type: none">• Additional trash reduction measures may be required
--	--	--	--	---



8. LOS Procedures

LOS assessments evaluate all trash regardless of the potential to discharge to receiving waters. The Trash Provisions define trash as “all improperly discarded waste material, including, but not limited to, convenience food, beverage, and other product packages, or containers constructed of steel, aluminum, glass, paper, plastic, and other natural and synthetic materials, thrown, or deposited on the lands and in the waters of the state”. “Trash generation” is a stormwater regulatory term used to describe the amount, or volume, of trash that is present within a segment in which some portion could enter storm drain inlets.

Caltrans requires District maintenance managers to implement the following LOS procedures when visually assessing the conditions of all litter in the State urban ROW.

1. Evaluate, record, and report on the current statewide inventory of 2,547 highly trafficked one-mile segments of highway every quarter in January, April, July, and October.
2. In District 4, evaluate, record, and report on the 314 centerline miles every quarter in January, April, July, and October. The pre-selected segments in District 4 are areas under CDO enforcement.
3. Evaluate, record, and report across all roadside hardscape and vegetated areas from right of way to right of way when visually assessing the litter and debris condition across the one-mile highway segments.
4. Conduct visual observations of localized instances of trash accumulation in urban areas within each 1/10 of a mile (528-feet). There are three trash assessment ratings (Need 0, Need 1, and Need 2) that each segment may be assigned based on the visual assessment, performed at low-speed driving when safe. If there are no localized instances of trash for the 10 - 1/10-mile sections, the 1-mile segment receives a Need 0, or a score of 100. If there is 1 localized instance of trash within one of the ten - 1/10-mile sections, the entire 1-mile segment receives a Need 1, or a score of 50. If there are 2 or more localized instances of trash within two or more of the ten - 1/10-mile sections, the 1-mile segment receives a Need 2, or a score of 0. Each corridor is then assigned a weighted score based on the scoring rubric assigned to each 1-mile segment within the corridor limit. Each district is also assigned an overall score by applying averaging all corridor scores within the district. Scores range from zero to 100, with 100 being the best. See image 1 for an example of the LOS rating based on localized trash accumulation.
5. Conduct visual observations of localized instances of trash accumulation in non-urban areas by:



- Determining the appropriate assessment intervals (i.e., every 10 - 25 miles) based on corridor characteristics such as centerline miles, historic annual litter production rates, and proximity to receiving waters; contingent upon State and Regional Water Board approval ; and
 - Assign a Need 2 rating if Caltrans finds, on average, that more than one moderate trash generating location per mile over any interval. Similarly, if Caltrans finds, on average, more than one high or very high trash locations per 5 miles within an interval, the interval would also be considered a Need 2 STGA.
6. There are three trash assessment ratings (Need 0, Need 1, and Need 2) that each segment may be assigned based on the visual assessment, performed at low- speed driving when safe.
- **Urban Areas:** If there are no localized instances of trash for the 10 - 1/10-mile sections, the 1-mile segment receives a Need 0, or a score of 100. If there is 1 localized instance of trash within one of the ten - 1/10-mile sections, the entire 1-mile segment receives a Need 1, or a score of 50. If there are 2 or more localized instances of trash within two or more of the ten - 1/10-mile sections, the 1-mile segment receives a Need 2, or a score of 0. Each corridor is then assigned a weighted score based on the scoring rubric assigned to each 1-mile segment within the corridor limit. Each district is also assigned an overall score by applying averaging all corridor scores within the district. Scores range from zero to 100, with 100 being the best. See image 1 for an example of the Urban LOS rating based on localized trash accumulation.
 - **In Non-urban Areas:** If there are no localized instances of trash for the 1-5 mile sections, the entire segment receives a Need 0, or a score of 100. If there is 1 localized instance of trash within one of the 1-5 mile sections, the entire segment receives a Need 1, or a score of 50. If there are 2 or more localized instances of trash within two or more of the 1-5 mile sections, the entire segment receives a Need 2, or a score of 0. Each corridor is then assigned a weighted score based on the scoring rubric assigned to each segment within the corridor limit. Each district is also assigned an overall score by applying averaging all corridor scores within the district. Scores range from zero to 100, with 100 being the best. See image 2 for an example of the Non-Urban LOS rating based on localized trash accumulation.
7. Assess each direction independently and assign a LOS trash rating.



8. Schedule assessments approximately half way between comprehensive litter collection events.
9. Identify, record, and report homeless encampments and designate the segment as very high trash generation, or need 2.

It should be noted that:

- The sole responsibility of LOS District maintenance supervisors is to perform visual assessments and assign trash ratings. They are not involved with the day-to-day litter removal activities that Caltrans maintenance crews perform;
- As per Standard Specifications and Special Provisions, construction zones are not evaluated as the maintenance responsibility for the construction zone is temporarily transferred to the contractor with Caltrans oversight; and
- The litter LOS visual assessments are independent of scheduled maintenance activities.

9. LOS Best Practices

Caltrans has developed the following LOS best management practices that are implemented for all District assessments:

1. Specific district maintenance supervisors are trained in two person teams to conduct slow-speed driving visual assessments, when safe, and are responsible for evaluating their routes ahead of time and have all equipment needed to record segment by segment observations.
2. District maintenance managers shall provide maintenance schedules (location and time) and designate a point-of-contact for any questions.
3. LOS assessments shall include the presence of all trash, regardless of size, for the entire ROW.
4. When conducting assessments on a highway segment or ramp, the width of the assessment area extends from the center line of the road (or middle of the median) to the edge of the right-of-way. It includes all areas, regardless of if trash has the potential to reach the stormwater drainage system, including but not limited to the median, highway, shoulder, ramps, and vegetated areas.
5. Vegetation in pervious medians or shoulders often captures and retains significant amounts of wind-blown pieces of trash. LOS assessors assign ratings of visual trash nuisance regardless of the potential for any vegetation-captured trash to discharge to the drainage system.



6. LOS assessments do not consider obstructions, such as a fence or dense vegetation, that would prevent trash from moving to the stormwater drainage system. All trash is included when assigning ratings.
7. Caltrans Headquarters reviews all data to identify and reconcile maintenance implementation issues and/or significant changes to litter removal.
8. Trash does not include sediment, sand, vegetation, oil and grease, exotic species, food waste (e.g., apple cores, banana peels), landscaping material that has been improperly disposed on the public right-of-way, and pet wastes. For this LOS protocol, mattresses, shopping carts, furniture, appliances, contained bags of trash, and all other illegally dumped items not capable of fitting in a storm drain inlet opening are included in the LOS assessment.

10. LOS Quality Assurance Practices

Caltrans Headquarters is responsible for following quality assurance practices:

1. Annual training sessions are conducted with each district to reinforce evaluation criteria, accompanied by photo and videos examples, to maximize statewide consistency in assigning trash ratings.
2. Two independent LOS trash assessments are conducted: 1 assessment by a District maintenance supervisor and a second by the HQ team.
3. Prior to start of the LOS litter assessments, Caltrans Headquarters performs a ride-along with District maintenance supervisors, as needed, to ensure LOS assessments are performed accurately and consistently.
4. If discrepancies between a District maintenance supervisor litter LOS score and the HQ team's litter LOS score are more than 10 points, then each corridor will be reviewed and compared to determine where the discrepancies occurred. The corridor(s) with such discrepancies may be re-evaluated again as needed.
5. Both the District litter LOS score and the HQ staff's litter LOS score are taken into consideration for final LOS litter scores.
6. If discrepancies can't be reconciled, the higher score will be used.
7. There is a minimum of one District LOS maintenance supervisor for each district that is trained and responsible for LOS trash assessment.
8. At the end of the evaluations, each District maintenance supervisor and Caltrans Headquarters staff will discuss the LOS assessment results to ensure accuracy.



Image 1: Urban LOS rating example based on localized trash accumulation.

Localized Instance

1 Instances of Trash

- NB = Need 1

0 Instances of Trash

- SB = Need 0

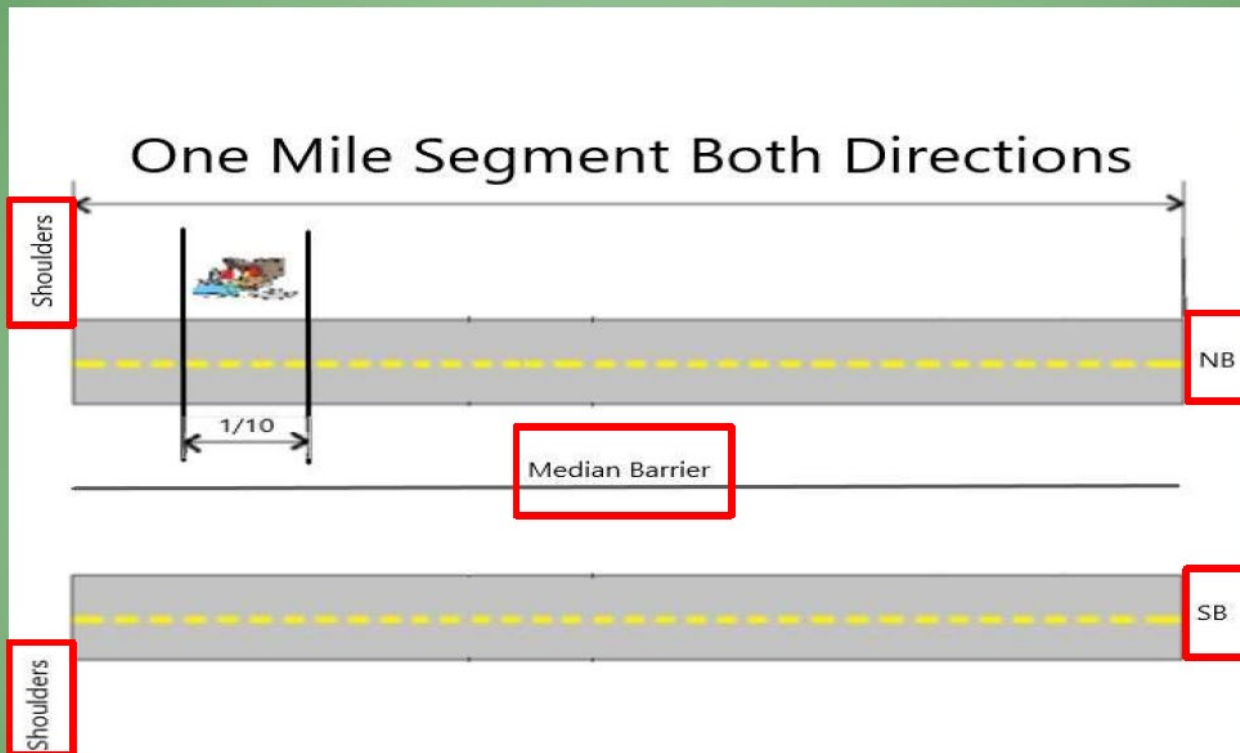



Image 2: Non-Urban LOS rating example based on localized trash accumulation.

Localized Instance

1 Instances of Trash

0 Instances of Trash

• NB = Need 1

• SB = Need 0

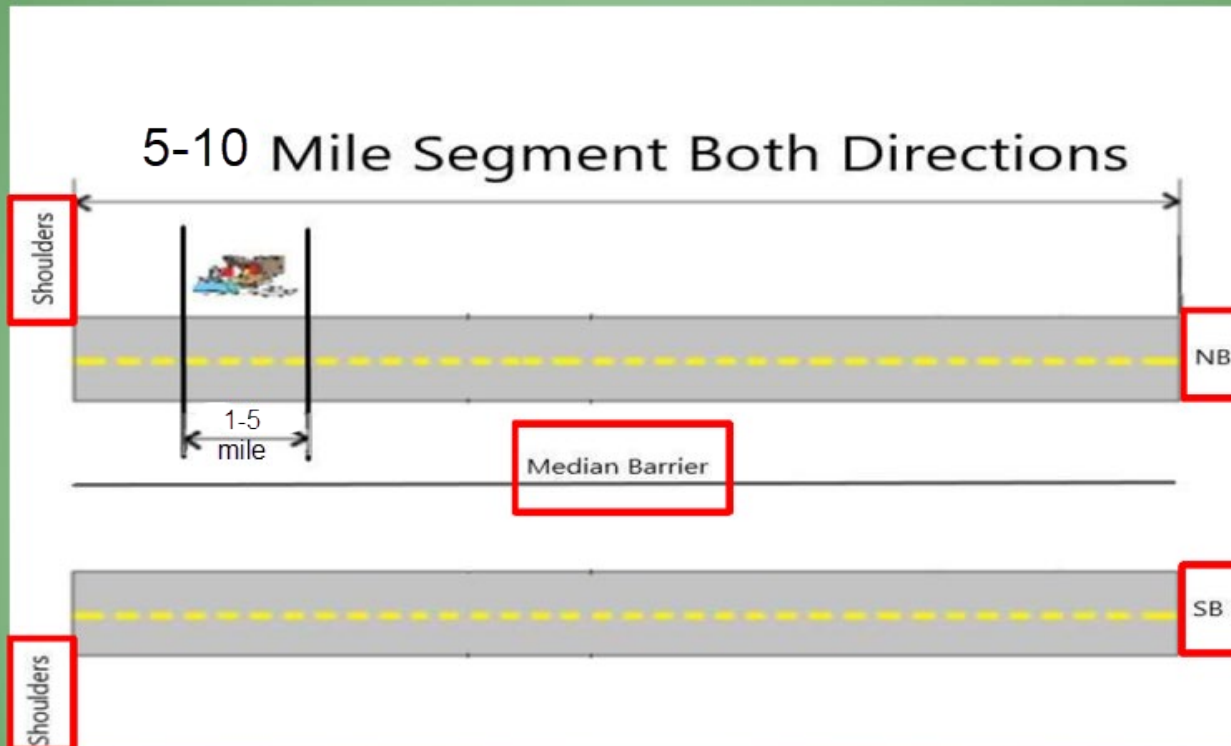

Attachment E:

Caltrans 2023 Encampment Survey Worksheet

Attachment F:

Urban Trash Discharge Design Study



Trash Discharge Design Study





Table of Contents

Executive Summary iii

1.0 Regulatory Background 1

 1.1 Statewide Trash Provisions 1

 1.2 Statewide Caltrans Permit 1

 1.3 The San Francisco Regional Water Board CDO 1

2.0 Studies Objectives 1

3.0 Study 1 – Urban Area Vegetation Control..... 2

4.0 Study 2 – Urban Area Maintenance Control 2

 4.1 Site Selection..... 2

 4.2 Records. 3

 4.3 Trash Assessment. 3

 4.4 Methodology. 3

 4.5 Outcomes..... 3

5.0 Study 3 – Non-Urban Maintenance Control..... 4

 5.1 Site Selection..... 4

 5.2 Records. 5

 5.3 Trash Assessment. 5

 5.4 Methodology. 5

 5.5 Outcomes 5

6.0 Caltrans Standard Procedures and Management 6

 6.1 GIS Desktop Evaluation..... 6

 6.2 Field Verification 6

 6.3 Litter Removal Activities by Maintenance Division 7

 6.4 Baseline Maintenance Frequency 8

 6.5 Maintenance Audits 8

 6.6 Full Trash Capture Systems..... 8

 6.7 Field Monitoring Teams 9

 6.8 Field Health and Safety Procedures..... 9

 6.9 Inspection Activities 9

 6.10 Monitoring Frequency & Measuring Trash Volumes..... 9

 6.11 Visual Assessments and Documentation 10

 6.12 Trash Characterization and Measurement..... 10

 6.13 Trash Collection 10

 6.14 Dewater/Remove Organic Debris..... 11

 6.15 Qualitative Description of Trash Profiling Details..... 11

 6.16 Sample Documentation 11

 6.17 Field Form..... 11

 6.18 Photographs..... 12



6.19	Sample Labeling.....	12
6.20	Sample Chain of Custody Forms and Custody Seals	12
6.21	Sample Containers and Labeling	13
6.22	Storm Event Data and Rainfall Totals	13
6.23	Data Evaluation and Reporting	13
6.24	Data Evaluation.....	14
6.25	Reporting.....	14
6.26	Quality Assurance and Quality Control.....	15
6.27	Adaptive Management	15
	Attachment 1: Site Selection Spreadsheets	17
	Attachment 2: Caltrans Trash Discharge Pilot Study Field Form.....	18
	Attachment 3: Grated Inlet Trash Screen (GITS™) Details	19
	Attachment 4: Inlet and Grate Details	20



Executive Summary

Attachment E of the June 22, 2022 Caltrans National Pollutant Discharge Elimination System (NPDES) Statewide Stormwater Permit¹ (Permit) requires Caltrans to submit an Amended Trash Assessment Methodology (TAM), that employs “technically acceptable and defensible assumptions” for determination of Significant Trash Generating Areas (STGAs) within non-urbanized highways. In addition, The Trash Provisions allow trash capture rates, for the purpose of demonstrating full capture equivalence, to be established either through pilot studies or literature review.

This document describes the California Department of Transportation's (Caltrans) Trash Discharge Design Study approach to demonstrate compliance with the Permit and, at least in part, the San Francisco Regional Water Quality Control Board (RWQCB) issued Cease and Desist (CDO) Order (Order No. R2-2019-0007). Both the permit and CDO requires Caltrans to demonstrate full capture equivalency at all significant trash generating areas (STGAs) where certified full capture systems are not installed.

In response to the CDO, Caltrans initiated and has completed a trash discharge study as described below:

Urban Vegetation Study (Study 1), initiated in 2020.

Caltrans has evaluated the effectiveness of vegetation in trapping trash and preventing the trash from discharging into storm drain inlets, with the goal of demonstrating full capture equivalence. To do this, Caltrans installed certified full capture systems (Systems) at 14 high traffic and vegetated locations in 2020 and has collected and measured the trash volume that is trapped in the Systems from the 2020-21, 2021-22, and the 2022-23 wet seasons. The selected locations for the study are locations where stormwater is directed through the vegetation before discharging into the storm drain inlets. These locations were accepted by the San Francisco Regional Board.

The final report will be completed by November 30, 2023. Subject to the approval of the San Francisco Regional Water Board and State Water Board, Caltrans will apply the outcomes of this study toward compliance at similarly vegetated areas within the San Francisco metropolitan area and statewide. Caltrans will develop statewide maps indicating the highway segments that are similar to those studied in this study for Water Boards' review and concurrence.

In response to the Permit and CDO, Caltrans has developed and will conduct two additional trash discharge studies. They are:



- Urban Freeway Study (Study 2), to be initiated in 2023.

Caltrans will evaluate the effectiveness of Caltrans trash maintenance removal efforts in preventing trash from entering storm drain inlets and demonstrating full capture equivalence in high traffic urban freeways. To do this, Caltrans will install inlet-based Systems at 40 high traffic locations, within the San Francisco and Los Angeles metropolitan areas, and collect and measure the trash volume that is trapped in the Systems. Unlike Study 1, these locations do not discharge stormwater through vegetation.

It should be noted that Caltrans obtained preliminary data on the efficacy of trash collection efforts by conducting a Trash Net Study. This study collected and measured trash from five trash net Systems during the 2022/2023 rainy season. These locations were deployed as part of CDO compliance and accepted by the San Francisco Regional Board. The results of this study indicate that Caltrans trash reduction efforts can reduce trash discharge to meet full capture equivalency. The Study and results are in Attachment H of the TAM. At the direction of the Water Boards, this study will continue.

- Non-Urban Study (Study 3), to be initiated in 2023.

Caltrans will evaluate the effectiveness of Caltrans trash maintenance removal efforts in preventing trash from entering storm drain inlets and demonstrating full capture equivalence in non-urban locations in northern California. To do this, Caltrans will install Systems at 30 locations in northern California, with ten of these locations located in high traffic non-urban freeways within the San Francisco Bay metropolitan area and collect and measures the trash volume that is trapped in the Systems. This Study is described below.

The State and Regional Water Boards will be consulted during the studies and as data is gathered to discuss any needed adaptive management and evaluate compliance. With the concurrence of the San Francisco Regional Water Board and the State Water Board, Caltrans will apply the outcomes of these studies toward compliance at similar highway segments within the San Francisco metropolitan area and statewide. Caltrans will develop statewide maps indicating the highway segments that are similar to those studied in these studies for Water Boards' review and concurrence.



**STATEWIDE TRASH COMPLIANCE
TRASH DISCHARGE DESIGN STUDY**

September 2023





Page intentionally left blank.



1.0 Regulatory Background

1.1 Statewide Trash Provisions

On April 7, 2015, the State Water Resources Control Board (State Water Board) adopted an amendment to the Water Quality Control Plan for the Ocean Waters of California to Control Trash and Trash Provisions of the Water Quality Control Plan for Inland Surface Waters, Enclosed Bays, and Estuaries of California.

1.2 Statewide Caltrans Permit

On June 22, 2022, the State Water Resources Control Board (State Water Board) adopted Order 2022-0033-DWQ National Pollutant Discharge Elimination System (NPDES) Statewide Storm Water Permit Waste Discharge Requirements (WDRs) for the State of California Department of Transportation (Permit). The Permit regulates stormwater and non-stormwater discharges from the Department of Transportation (Caltrans) right-of-way (ROW). The Permit became effective on January 1, 2023. The Permit contains existing trash TMDLs adopted by the Los Angeles Regional Water Board.

1.3 The San Francisco Regional Water Board CDO

The San Francisco Regional Water Board adopted the CDO on February 13, 2019 and adopted a revision on December 17, 2021. The CDO contains trash reduction requirements that apply within the jurisdiction of the San Francisco Bay Region Water Board. The Permit does not alter the enforceability of the CDO. The CDO was adopted prior to the Permit, and there is much overlap and some differences between the requirements. However, each have the ultimate goal of achieving compliance with the Trash Provisions so Caltrans has prepared this document to comply with the Permit and to maximize compliance with the CDO.

2.0 Studies Objectives

The objectives of the three trash discharge studies are:

- To determine the amount of trash in, gallons/acre/year, that enters the storm drain inlets through flush mounted 1-3/8" grate openings in various settings.
- To determine the amount of trash in, gallons/acre/year, that resides on top of the flush mounted storm drain inlet grates that would otherwise enter the less common curb opening inlet scenario.



- To determine the standard maintenance frequency to be conducted at all locations needed to demonstrate Full Trash Capture Equivalency in various settings.
- Determine actual discharge rates as an alternative to conducting OVTAs as defined by the Bay Area Stormwater Management Agencies Association (BASMAA) OVTA Study for municipalities.

It should be noted that OVTAs will still be conducted to identify initial significant trash generation areas (STGAs) in urbanized ROW and in some non-urbanized ROW. Caltrans trash assessment protocols are outlined in the Trash Assessment Methodology (TAM).

- Utilize the results of the study to apply statewide where applicable.

3.0 Study 1 – Urban Area Vegetation Control

Study 1 methodology to comply with the CDO has already been established and three years of monitoring completed. Some revisions to the report, including credit delineation protocols, have been made in response to comments on the draft TAM. This study employs the same standard procedures and management as described in Section 6 below.

4.0 Study 2 – Urban Area Maintenance Control

The key elements of the Urban Area Maintenance Control Study are described below:

4.1 Site Selection.

40 locations have been selected in the Los Angeles Region and San Francisco Bay metropolitan urban areas. These locations were selected using selection criteria that includes OVTA trash generation ratings, number of travel lanes, drainage area size, traffic volumes, population, geographic settings, and adjacent land use (commercial, industrial, and residential). Attachment 1 includes detail of each selected location.

Caltrans Headquarters worked with each of the five affected District Maintenance managers to go through a verification process to identify and confirm the adequacy of candidate locations. The inlet-based monitoring has been designed to ensure that a variety of settings and types of trash generation rates are represented within the overall stormwater inlet monitoring scheme. In general, a three-step process was used to select stormwater inlets for trash monitoring.



During the initial desktop screening exercise, many inlets were eliminated for the following reasons: access issues, proximity to live traffic, or insufficient ingress / egress for field teams. Field reconnaissance was conducted at all proposed inlets that were not eliminated for logistical considerations based on desktop analysis. The majority of the inlets evaluated in the field were eliminated for the following reasons: inlet characteristics not suitable for trash inlet insert Systems, poor accessibility, or unsafe (e.g., illegal encampments or active construction).

Systems will be temporarily installed to monitor trash entering the Systems over a two-year study period.

4.2 Records.

Quantitative Integrated Maintenance Management System (IMMS) trash collection records for the past two fiscal year and throughout the duration of the study will be collected, tabulated, and reviewed to establish baseline trends to ensure consistency throughout the monitoring period. The maintenance records will be tabulated and the data from each of the three distinct litter collection activities presented that itemizes the monthly frequency and monthly litter production for each study location.

4.3 Trash Assessment.

Records of all past and future OVTA trash generation ratings as well as Level of Service visual assessments will be collected, tabulated, and reviewed for all study locations. Visual assessments will be performed during each monitoring event to document any change in trash loading. These records will also establish trends in the study locations and will be used to compare to the IMMS data. A comparison of the Level of Service litter ratings and OVTA ratings are presented in Attachment D of the TAM.

4.4 Methodology.

The volume of trash collected will be measured monthly during the wet season (October through May) and quarterly during the non-rainy season for each of the forty locations. The five trash net Systems will be monitored annually in April. The results will be compared to the BASMAA study threshold of 5 gallons/acre/year established for a low trash generation classification. Caltrans will implement the methodologies described in Section 6 below.

4.5 Outcomes.

If the study verifies low trash discharge volumes, in consultation with the State Water Board, it will be assumed full capture equivalence has been established and that other similar rated locations are also low. If the study does not verify the



low discharge volumes and full capture equivalence, in consultation with the State Water Board, Caltrans will either enhance maintenance activities and redo the study at appropriate locations, or install permanent Systems at all similar locations. This trash discharge study could be used, in consultation with the San Francisco Regional Water Board, to substantiate CDO maintenance credits.

The findings of the study will be documented in annual reports scheduled to be complete by July of each year. The State and Regional Water Boards will be consulted during the studies and as data is gathered to discuss any needed adaptive management and evaluate compliance. Phase II.

Caltrans over the next three (3) years will:

- Survey the urban areas ROW to identify highway segments that include curb opening inlets. Curb inlets allow trash greater than 1 and 3/8th inches to enter the inlet which may impact the trash discharge rating;
- Install ten (10) Certified Full Capture Systems at locations selected in coordination with the State and Regional Water Boards;
- Collect and measure the trash entering the inlets;
- Determine the trash discharge rating (low, moderate, high, very high) for each location; and
- Depending on the trash discharge rates, enhance trash collection maintenance to achieve full trash capture equivalency, and collect and measure the trash entering the inlets an additional year to demonstrate full trash capture equivalency.

5.0 Study 3 – Non-Urban Maintenance Control

The key elements of the Non-Urban Maintenance Control Study are described below:

5.1 Site Selection.

20 non-urban locations will be studied in northern California in areas presumed to be of low trash generation rating (see Preliminary Non-Urban Design Study). These locations were identified using selection criteria that includes receiving water, number of travel lanes, drainage area size, and traffic volumes. An additional 10 non-urban high traffic locations in the San Francisco Bay Areas will be studied. Caltrans Headquarters worked with each of the five affected District Maintenance managers to go through a verification process to identify and confirm the adequacy of candidate locations to conduct the inlet-based monitoring to best ensure that a variety of settings are represented within the overall stormwater inlet monitoring scheme. In general, a three-step process was



used to select stormwater inlets for trash monitoring. Attachment 1 includes detail of each selected location.

During the initial desktop screening exercise, many inlets were eliminated for the following reasons: access issues, proximity to live traffic, or insufficient ingress / egress for field teams. Field reconnaissance was conducted at all proposed inlets that were not eliminated for logistical considerations based on desktop analysis. The majority of the inlets evaluated in the field were eliminated for the following reasons: inlet characteristics not suitable for trash inlet insert Systems, poor accessibility, or unsafe (e.g., illegal encampments or active construction).

Systems will be temporarily installed to monitor trash entering the Systems over a two-year study period.

5.2 Records.

Quantitative IMMS trash collection records for the past two fiscal year and throughout the duration of the study will be collected, tabulated, and reviewed to establish baseline trends to ensure consistency throughout the monitoring period. The maintenance records will be tabulated and the data from each of the three distinct litter collection activities presented that itemizes the monthly frequency and monthly litter production for each study location.

5.3 Trash Assessment.

Trash generation ratings have been established for each location using the IMMS litter production crosswalk established in the Initial Trash Discharge Ratings for Non-urbanized Highways, Attachment G of the TAM.

OVTA visual assessments will be performed during each maintenance event to document any change in initial trash loading.

5.4 Methodology.

The volume of trash collected will be measured monthly during the wet season (October through May) and quarterly during the non-rainy season for each of the thirty locations. The results will be compared to the BASMAA study threshold of 5 gallons/acre/year established for a low trash generation classification. Caltrans will implement the methodologies described in Section 6 below.

5.5 Outcomes

If the study verifies the low trash ratings, in consultation with State Water Board, it will be assumed that other low rated locations are also low. If the study does not verify the low ratings and full capture equivalence, in consultation with the State



Water Board, Caltrans will enhance maintenance activities and re-do the study at the locations that resulted in a higher rating.

The findings of the study will be documented in annual reports scheduled to be complete by July of each year. The State and Regional Water Boards will be consulted during the studies and as data is gathered to discuss any needed adaptive management and evaluate compliance.

6.0 Caltrans Standard Procedures and Management

Caltrans will manage all the studies in accordance with the following standard procedures and management:

6.1 GIS Desktop Evaluation

Stormwater inlets for trash monitoring were evaluated for each district by conducting a GIS analysis of “baseline” trash generation for the associated catchments. Baseline trash generation assumptions are based on the outputs from the BASMAA San Francisco Bay Regional Trash Generation Rates Project (EOA 2014), visual field assessments, and local knowledge. Baseline trash generation levels are depicted on maps and serve as the starting point for each District’s Long-Term Trash Implementation and Reduction Plans. Caltrans locations are mapped as low, moderate, high, or very high STGA based on this information. The results of the analysis identified inlet catchments in GIS that create a diversity of trash generation and land use representativeness.

Desktop analysis incorporated available storm drain information (i.e., pipes, inlets, outfalls), satellite imagery, and Google Street View. The Caltrans Stormwater Program reviewed inlet locations (main lanes, ramps, low points), inlet catchment locations, adjacent land use (commercial, residential), and locations associated with trash control measures to identify potential inlets for trash monitoring.

6.2 Field Verification

Caltrans inlets and associated stormwater runoff catchments identified in Step 1 were then further assessed. Following the selection of inlets as outlined above, the next step was to determine suitability for trash monitoring using inlet-based Systems. Stormwater inlets suitable for trash monitoring must have certain characteristics that are conducive to basic safety and logistical criteria, including the following:

- The stormwater inlet should be located in an area that does not pose serious safety risks to field personnel. For example, inlets located near encampments are generally not considered safe and are vulnerable to equipment theft and vandalism.



- The stormwater inlet should avoid active construction zones and be accessible for field personnel to safely deploy and retrieve the content with the inlet-based inserts for each monitoring event. The inlet should be near a Maintenance Vehicle Pullout (MVP) or wide shoulder to park a vehicle, with an attenuator truck in tow, to retrieve the wet trash and debris content.
- The System within the drainage inlet must not cause flooding. Operation of an inlet-based System could slow or block flows and cause upstream flooding resulting in hazards to the traveling public. Maintenance Managers have been instructed to remove the Systems should there be indications of flooding as a result of the installation.
- High visibility markers will be placed on all study inlets with retrofitted trash capture Systems, so maintenance crews know not to perform drain inlet cleaning.

6.3 Litter Removal Activities by Maintenance Division

Quarterly maintenance will be implemented as described in the studies. Caltrans Headquarters requires each District maintenance manager to constantly monitor their areas of responsibility to detect. The following litter collection activities are utilized by District maintenance managers to meet stormwater regulatory mandates and address public complaints submitted by the public through the customer service request website:

1. Comprehensive Litter Collection (scheduled crews for entire corridors)
2. Freeway Litter Sweeping (Mechanized sweepers scheduled for entire corridors)
3. Litter Incident Response (continuous corridor attention to known regeneration areas and / or public service requests)
4. Encampment Related Litter Collection and Removal
5. Adopt-A-Highway Volunteer Litter Collection

Items 4 and 5 are not included in the baseline maintenance frequency due to variabilities.

Maintenance activities and visual observations during the studies will be tracked by Caltrans Headquarters.



6.4 Baseline Maintenance Frequency

A review of Caltrans' IMMS data will be used to verify the historic frequency of litter removal activities within a corridor. Caltrans IMMS is a database used to record and manage maintenance effort through work orders. IMMS, used as an asset management tool, allows District Maintenance Supervisors and managers to track effort across the various litter collection activities. IMMS tracks litter collection expenditures and production in cubic yards, for all material collected regardless of meeting the definition of trash or its ability to be transported during rain events.

Once the study site locations are selected and prior to any field data collection of trash discharge volumes, the study leads will engage with District maintenance managers to discuss the historic frequency of litter collection activities at each location and ensure those are consistently applied throughout the study period. The study team will review IMMS records from the past two years to determine the frequency of comprehensive litter collection, freeway litter sweeping, and litter incident response.

Prior frequency of litter collection activities and associated production volumes in cubic yards will be determined for 5 miles in either direction of each study inlet. This will establish baseline maintenance effort in the proximity of the drainage inlet since IMMS work orders do not detail effort down to the granular level of drainage inlet catchment locations. Before the study begins and throughout the study period, District maintenance managers will be required to maintain the baseline effort established from the IMMS review to avoid skewing the results of the study.

6.5 Maintenance Audits

Throughout the studies, Caltrans Headquarters will review the IMMS litter collection and assessment data to detect deviations in maintenance efforts and/or litter collected. Any substantial deviations will be flagged. Quarterly audits with the District maintenance managers will determine if corrective actions are needed, or the trash rating of the locations have changed.

6.6 Full Trash Capture Systems

Certified full capture catch basin insert systems were selected to monitor trash accumulation in this study. Referencing the State Water Board Executive Director's list of certified full capture systems, G2 Construction, Incorporated's Grated Inlet Trash Screens (GITS™) will be custom installed at each of the monitoring location inlets. The inserts consist of a stainless-steel collection basket with 5mm perforations and are sized to meet the 1-year, 1-hour storm event. Details of the GITS devices are included in Attachment 3.



The systems are suspended within the drop inlet with the weight of the grate securing them into place. Inlet and grate details are presented in Attachment 4. Perimeter steel panels direct all flows into the center of the receiving basket. A 6-inch opening along the top of the basket serves as an emergency overflow. The systems will be monitored and cleaned free of all trash and/or debris on a monthly basis during the rainy season to ensure full capacity at all times. Field observations will verify if the emergency overflow weir was ever used. Metal placard signage will be fastened to each monitoring inlet grate to identify the study locations and alert Caltrans maintenance crews to refrain from cleaning in or around the inlet throughout the duration of the study.

6.7 Field Monitoring Teams

Site monitoring will be conducted by field teams consisting of two individuals with traffic control backup to ensure safety and provide quality assurance and quality control (QA/QC). To reduce variability in field observations, all field personnel received both virtual and in-field training. The training included review of the Caltrans OVTA Protocol, with a specific focus on trash categorization. Field training consisted of visiting each monitoring location as a group to review site conditions, drainage, access to the systems, and safety. During this training, visual observations will be baselined with all field personnel.

6.8 Field Health and Safety Procedures

All field staff will be expected to abide by their study-specific health and safety plan (HASP). The HASP will identify specific hazards and mitigation measures associated with project implementation.

6.9 Inspection Activities

District Maintenance Supervisors will document qualitative information about the overall site condition. Maintenance staff will then remove the inlet grate, remove trash from the inlet insert, and measure the types of trash and volume of trash captured by the inlet inserts. If trash was present in the insert, the types of trash were further broken down into percentages. The District Maintenance Supervisors will record any indications that maintenance had been completed by either non-Caltrans litter collection staff (as indicated by yellow bags), or volunteer trash removal programs such as the Butte County Office of Education Back2Work program, or the Adopt-A-Highway program (white bags).

6.10 Monitoring Frequency & Measuring Trash Volumes

Caltrans requires two-person field teams to access each study location. These teams will separately quantify all trash that has accumulated both on top of the grate and within the inlet insert on a quarterly basis during the summer and on a



monthly basis during rainy season between October 1 and May 31. The volume (gallons) of captured trash on top of the grate will demonstrate the effectiveness of the 1 and 3/8" grate in preventing trash from entering inlet. The trash trapped within the inlet will demonstrate the effectiveness of the trash removal maintenance to remove trash sizes between 5mm and 1 and 3/8". District Maintenance Supervisors are required to document maintenance activity observations, rainfall information, and trash discharge observations.

6.11 Visual Assessments and Documentation

Caltrans will conduct visual assessments of the ROW in study locations at the time of monitoring to help document the current trash generating condition. IMMS records will also be evaluated to establish maintenance activity frequencies and production to when analyzing how the amount of trash discharged may vary depending on the maintenance actions implemented and the amount of trash visible on the ROW. Baseline and on-going visual trash assessments will provide data needed to draw conclusions from observed trash discharges. Visual assessments will be documented on field forms.

6.12 Trash Characterization and Measurement

The goal of the trash characterization step is to measure and characterize the trash discharged into stormwater inlets during each monitoring event with a known level of accuracy and precision, using methodologies that are comparable to those used to develop San Francisco Bay Region trash generation rates (EOA 2014) and that provide the resolution necessary to adequately address the objectives of this study.

When conducting trash characterization, the following steps will be performed in the order presented:

- Step 1: Trash/debris collection and transport;
- Step 2: Dewatering/removal of organic debris; and
- Step 3: Trash characterization and measurement.

Each step is described in more detail below.

6.13 Trash Collection

During each monitoring event, field staff will extract contents from on top of and within the inlets separately and place in designated containers. The contents will be placed into the truck for transport to an offsite dewatering and storage location. Chain-of-custody forms will be completed prior to leaving the site.



6.14 Dewater/Remove Organic Debris

Extracted inlet material will be stored at a secure location for 1-2 days to allow for the water to drain out. Alternatively, trash and debris can be placed into mesh bags that allow water to drain. Following the drying period, the material will be placed on a large table that will be used to separate trash from organic debris (e.g., soil, sand, leaves, branches). Trash will be placed into storage bags (e.g., garbage bags or mesh bags) and the organic debris will be disposed of appropriately. Only trash items larger than 5 mm in diameter will be kept for characterization and measurement at a later date. Bags containing the trash will then be labeled and stored in a secure dry location. Bags should be labeled with site code, sample date, field staff, and date of disposal. Chain-of-custody forms will be updated accordingly and kept with the labeled trash bags.

6.15 Qualitative Description of Trash Profiling Details

During site monitoring events, quantitative and qualitative details regarding the collected trash profile will be recorded on the Field Form included in Attachment 2. Field teams will determine the volume of trash collected at both the inlet grate and catch basin insert. Based on observation, the team will assess the overall composition of the collected trash by categorizing it into relative percentages of material classifications. Any other visual observations of the site will be documented on the Field Form. After characterization is completed, trash will be properly disposed of in accordance with all federal, state, and local regulations.

6.16 Sample Documentation

Individual field crews will be responsible for generating sample documentation in the field. Methods of field documentation are described below.

6.17 Field Form

All field and quantification data gathered by these studies will be recorded on the Trash Discharge Study Field Form (Attachment 2). Information will be photocopied or scanned and delivered to the monitoring coordinator. All entries should be legible, initialed, and signed by the individual making the entries.

Data will be collected in the field associated with each deployment and retrieval event (Field Form) and during separate quantification efforts. Field Forms shall include at a minimum:

- Site and sample IDs
- Date and time of sample collection, including both deployment and retrieval operations
- Names of crew members



- Narrative description of conditions at the sampling site
- Summary of any meetings or discussions with subcontractor or agency personnel
- Other relevant information such as current and antecedent weather conditions
- Deviations from sampling plans, site safety plans, and QAPP procedure
- General Site Information
- Maintenance Observations
- Trash Observations
- Photographic Documentation

6.18 Photographs

Photographic documentation is an important part of sampling procedures. At a minimum, monitoring personnel shall collect photos of the condition of the Full Capture inlet insert. Staff should also document any conditions within the monitoring site or the upstream catchment that may affect interpretation of flow or trash characterization/measurement results. An associated photo log will be maintained, documenting sites and subjects associated with photographs.

6.19 Sample Labeling

All samples collected will be labeled in a clear and precise way for proper identification in the field and for tracking at the dewatering facility. At a minimum, the sample labels will contain the following information: station ID and date of collection. Site IDs are listed in Attachment 1.

Each sample collected for the studies will be labeled according to the following naming convention:

SITE-YYYYMMDD-CC

where:

SITE = Site ID (e.g., XXXX)

YYYYMMDD = Date of monitoring

CC = Monitoring component (Top of inlet versus inside)

6.20 Sample Chain of Custody Forms and Custody Seals

All samples transferred for characterization will be accompanied by a chain-of-custody record (COC). The COC will identify the contents of each shipment and maintain the custodial integrity of the samples. Generally, a sample is considered



to be in someone's custody if it is either in someone's physical possession, in someone's view, locked up, or kept in a secured area that is restricted to authorized personnel. Until the samples are transferred or shipped, the custody of the samples will be the responsibility of the District Maintenance Supervisor. The sampling team leader or designee will sign the COC in the "relinquished by" box and note date and time.

If possible, a self-adhesive custody seal or custody tape will be placed across the closing of each bucket or trash bag. The containers in which samples are stored (e.g., bag, bin) will be sealed with self-adhesive custody seals any time they are not in someone's possession or view. All custody seals will be signed and dated.

6.21 Sample Containers and Labeling

Field crews should properly store trash samples to ensure their integrity through the dewatering, sorting, and characterization/measurement process. During retrieval operations, each bag / bucket will be labeled with its site ID and sample date by use of a cattle tag or other identifier that is wired or cable-tied to the bag / bucket. Bags / buckets will then be transported to a secure location where they will be allowed to dewater.

All accumulated trash and vegetative debris should be removed during the sorting process, and vegetative debris should be removed and disposed of appropriately. Vegetative debris will be carefully inspected to ensure all trash items are removed. Forceps will be used as required to remove smaller items. Following dewatering and removal of organic debris, trash will be transferred to a heavy-duty garbage bag for storage until trash characterization can be conducted. If a large volume or heavy mass is encountered, sampling personnel may double-bag the trash. The cattle tag or other identifier will be transferred from the bag / bucket to the bag / bucket containing the trash, along with an adhesive label as supplemental method of identification and moved to a secure location to characterize/measure at a later time.

6.22 Storm Event Data and Rainfall Totals

During the study, a summary of all storm events that occur during the reporting period will be compiled. This includes recordkeeping of storm durations, individual storm intensities, rainfall totals, and monthly totals. Rainfall data will be obtained from the nearest National Oceanic and Atmospheric Administration (NOAA) rain gauge.

6.23 Data Evaluation and Reporting

Measured trash volumes will be used in conjunction with tributary drainage areas (acres) to calculate trash discharge rates in gallons/acre/year. Results of the



discharge data from the 10 very high, 10 high, 10 moderate, and 10 low rated trash generating sites will be evaluated to determine if sufficient consistency exists to determine if maintenance efforts are sufficient to establish partial or full trash capture equivalency, which would equate to low discharge rating as compared to the 5 gallons/acre/year threshold. Secondary information may also be derived from the results, such as further substantiating the LOS visual assessment process or differences in trash regeneration across variable site characteristics.

6.24 Data Evaluation

This trash discharge study presents an overall approach for assessing whether the visual nuisance of trash, coupled with institutional maintenance management actions in monitored inlet drainage catchments, have effectively controlled trash to a low trash generation rate (i.e., <5 gallons/acre/year).

Methods used to monitor trash discharged into stormwater drainage inlets include the continuous collection of trash using inlet-based certified full trash capture systems from selected locations during the rainy season (i.e., October – March). Trash characterization and measurement methods include sorting of collected trash into relevant categories and measuring the volume of trash in each category.

The data evaluation methods will employ a combination of graphics and charts to calculate and assess trash capture rates and trash types across sites and across time. The parameters to be evaluated include trash discharge rates during monitoring events, meteorological data, and the types of trash observed in stormwater discharges.

Annual trash load data will be evaluated within the context of the contributing catchment area (e.g., types of trash control measures present, trash generation rates, and overall catchment size).

Trash characterization data generated for each sample will be tabulated, graphed, and assessed based on the storm characteristics observed during sample collection. Comparisons of trash characterization data between sites will also be evaluated and presented using a combination of graphics and charts.

6.25 Reporting

A Trash Discharge Report describing the results of inlet monitoring using the data evaluation methods described in this design study will be prepared. The Trash Discharge Report will be submitted by July of each year and will address data collected. The Trash Discharge Report will include the following information:

- Narrative description of monitoring conducted, including the number of sites monitored and the number of monitoring events completed.



- Description of storms events, including the date(s) and times, intensity and duration of the storm event.
- Narrative description, including maps of the inlets, homeless encampments, and illegal dumping sites, located upstream of each inlet monitoring sample site.
- Description and the results of trash discharge volumes and maintenance activity data.
- Results and lessons learned.
- Data quality assurance procedures implemented for samples collected.

6.26 Quality Assurance and Quality Control

To ensure consistency in visual observations and reporting, multiple QA/QC measures will be implemented. All field monitoring will be conducted in teams of two, allowing discussion and confirmation of all observations. Monitoring crews will also be assigned to the same site locations, when reasonably feasible, throughout the duration of the study to provide consistency in observations. Upon completion of field data collection, all inspection reports and photos were reviewed by an independent individual. Any discrepancies in reported observations were then discussed with field personnel for verification and agreement. As a final check, 1-2 site monitoring forms were audited by a second, independent individual for confirmation of data on a monthly basis.

6.27 Adaptive Management

The studies lay out a detailed approach for addressing respective management questions through monitoring. Various aspects of sample collection, analysis, and interpretation have been identified and will be followed.

It is understood, however, that changing circumstances or understanding gained through study implementation may require modifications to the overall monitoring approach or site-specific protocols to best meet monitoring objectives. The monitoring program therefore acknowledges and incorporates some degree of adaptive management into its operating procedures.

Recognizing that the scale and relative urgency of issues faced may vary significantly over the course of the studies implementation, field staff will use best professional judgment to make minor modifications to the protocols identified in each study to respond to changing conditions in the field that require immediate action or risk jeopardizing data collection efforts. These modifications will be recorded and sent to Caltrans Headquarters. Caltrans Headquarters will notify the State Water Board of substantive issues that may require a higher level of coordination with Water Boards' staff.



**STATEWIDE TRASH COMPLIANCE
TRASH DISCHARGE DESIGN STUDY**

September 2023



Changes adopted over the course of the studied implementation will be formalized in addenda to the design studies as appropriate.



Attachment 1: Site Selection Spreadsheets



Attachment 2: Caltrans Trash Discharge Pilot Study Field Form





Attachment 3: Grated Inlet Trash Screen (GITSM) Details





Attachment 4: Inlet and Grate Details



Common Inlet Grate



Less Common Curb Opening Inlet

Attachment G:

Non-Urban Initial Trash Rating Methodology



Statewide Stormwater Permit

INITIAL TRASH DISCHARGE RATINGS FOR NON-URBANIZED HIGHWAYS

1. Summary.

Attachment E of the June 22, 2022 Caltrans National Pollutant Discharge Elimination System (NPDES) Statewide Stormwater Permit¹ (Permit) requires Caltrans to submit an Amended Trash Assessment Methodology (TAM) to determine significant trash generating area (STGAs) including baseline trash generation.

- For urbanized Caltrans ROW, the Permit specifically requires Caltrans to implement the On-Land Visual Trash Assessment (OVTA) protocol. Prior to the adoption of the Permit, Caltrans had already expended considerable resources to conduct OVTAs at 849 urban centerline miles. As described in section 4 of the TAM, Caltrans will conduct additional OVTAs for 1,974 urban centerline miles.
- For non-urbanized Caltrans ROW, the Permit allows Caltrans to develop an alternative trash assessment protocol that employs “technically acceptable and defensible assumptions”. In addition, The Trash Provisions allow full capture equivalence to be demonstrated either through pilot studies or literature review. Prior to adoption of the Permit, Caltrans had not conducted trash assessments of 10,794 non-urban centerline miles nor had developed a cost-effective and accurate method of doing so.

This document describes Caltrans trash assessment methodologies to:

- Initially identify STGAs and the estimated baseline trash generation for 10,794 center-miles of non-urbanized highways based upon specific reasonable assumptions; and
- Conduct two trash assessment studies designed to support or refine the assumptions made in the non-urban initial trash assessment methodology.

2. **Integrated Maintenance Management System (IMMS)**

The Division of Maintenance removes litter, debris, and sediment to help maintain traffic safety (for both motorized and non-motorized travelers and workers), protect water quality, maintain adequate drainage, and provide visually pleasing highways. Caltrans has recently significantly improved these efforts per the Governor’s 2021 Clean CA initiative.

1. State Water Resources Control Board Order 2022-033-DWQ Statewide Municipal Stormwater Permit for the California Department of Transportation
2. California Regional Water Quality Control Board San Francisco Bay Region Cease and Desist Order No. R2-2019-0007 or the California Department of Transportation, as amended by R2-2021-0007



Caltrans IMMS is a database used to record maintenance litter collection information by activity-specific work orders. IMMS data is used to determine trends across the ROW, such as known areas with consistent trash generation, that require heightened resources.

As part of their required routine tasks, Caltrans district maintenance managers drive and inspect all non-urban highways within their district area of responsibility, including ramps and collector systems, at least once a week to observe overall conditions and detect deficiencies. Caltrans district maintenance managers utilize their field inspections to adaptively manage resources to maximize removal for all litter, including trash, regardless of size. It should be noted that trash removal can be temporarily delayed if litter removal requires lane closures and/or if safety concerns require more upfront logistics, planning, and resources.

Caltrans district maintenance managers are required to record and enter into the IMMS database:

1. Comprehensive Litter Collection (corridor specific scheduled crews)
2. Freeway Litter Sweeping (corridor specific scheduled mechanized sweeper crews)
3. Litter Incident Response (continuous corridor attention to known regeneration areas and / or public service requests)
4. Encampment Related Litter Collection and Removal
5. Adopt-A-Highway Volunteer Litter Collection

Note: The locations and frequency of items 4 and 5 are highly variable.

Caltrans Headquarters reviews the IMMS data to ensure litter collection activities are utilized by Caltrans district maintenance managers to meet stormwater regulatory mandates and address public complaints submitted through the customer service request website.

3. Determination of Initial Trash Discharge Ratings

Caltrans has developed a non-visual trash assessment methodology to initially identify STGAs and the estimated baseline trash generation using the following data and procedures:

- Quantitative trash collection records from IMMS;



- Volumes of trash trapped at fourteen urban vegetative control sites to comply with the San Francisco Bay Regional Water Board's Cease and Desist Order (CDO)². Although the study is on-going, a draft report will be attached to the TAM with the subsequent final study provided to State and Region 2 Water Board staff;
- Volumes of trash trapped within five urban area trash nets installed to comply with the CDO. Although this study is on-going, year 1 results have been included herein and provided to State and Region 2 Water Board staff;
- The data gathered from the Vegetative and Trash Net studies conducted to comply with the CDO supports the initial correlation of 30 yards/acre/year as representative of a low OVTA trash rating of 5 gallons/acre/year.
- Maintenance litter removal quantities as correlated to the On Land Visual Trash Assessment (OVTA) trash generation ratings assigned to the aforementioned vegetative and trash net control site;
- Range of trash removal in cubic yards/mile/year translated to gallons/acre/year for each trash rating established by the OVTA (low, moderate, high, and very high) for the non-urbanized highway segments;
- Segments initially designated as moderate, high, or very high trash discharge based upon the IMMS cubic yard removal thresholds and assumptions explained below will initially be considered STGAs;
- Segments that are initially determined to be a low trash discharge rating based upon the IMMS cubic yard removal thresholds and assumptions explained below may later be considered meeting full capture equivalence as accepted by the State Water Board based upon the non-urban trash assessment studies and, where necessary, future enhanced maintenance and additional studies;
- District maintenance managers will review the discharge ratings relative to their knowledge of trash profile characteristics and connections to receiving waters to determine if increased ratings are warranted; and
- All assumptions used to initially identify STGAs and trash ratings will be refined subject to future studies included in the TAM. This includes, but not limited to, the percent trash content relative to total litter collected, proportion of trash that can physically enter the storm drain system, and the percent of the state highway system storm drain system that does not discharge to adjoining fields.



4. Initial Trash Ratings

4.1 Assumptions

To determine initial “low” trash discharge ratings, Caltrans applied technically acceptable and defensible assumptions to convert IMMS trash collection data to develop a threshold that corresponds to the widely accepted OVTA threshold of 5 gallons/acre/year. Caltrans has included margins of error for each assumption. The assumptions used to convert IMMS litter collection data to gallons/acre/year are:

- A. Twenty percent (20%) of all collected litter is trash as defined by the Trash Provisions³

The Trash Provisions define trash as “All improperly discarded solid material from any production, manufacturing, or processing operation including, but not limited to, products, product packaging, or containers constructed of plastic, steel, aluminum, glass, paper, or other synthetic or natural materials”.

The overwhelming majority of litter that Caltrans maintenance crews remove consists of large objects such as tires, metal parts, illegally dumped appliances, as well as vegetation and sediment. Caltrans generally estimates that trash as defined in the Trash Provisions is generally less than ten percent of the total material collected. This is supported by hand sorted trash conducted by Caltrans staff as required by the CDO.

For the purposes of determining trash discharge ratings, Caltrans will use a factor of Twenty percent (20%).

- B. Forty percent (40%) of non-urbanized highways are connected to storm drain system discharging to receiving waters.

Unlike urban freeway where stormwater is mostly collected in impervious storm drains that discharge to receiving waters, the majority of stormwater both:

- Sheet flows off the pavement into pervious medians or roadside ditches where a significant amount of stormwater infiltrates into the ground and evaporates. Some studies suggest that, in non-urban

3. State Water Resources Control Board Resolution 2015-0019 Amendment to the water quality control plan for oceans waters of California to control trash and part 1 trash provisions of the water quality control plan for inland surface waters, enclosed bays, and estuaries of California.



- settings, generally 30-40% of stormwater evaporates and infiltrates into the ground and therefore can't be discharged; and
- Collects in storm drains that discharge to adjoining fields which has little impact to receiving waters. A preliminary survey of the Caltrans non-urban ROW suggests that more than 70% of the stormwater that does discharge off of its non-urban ROW enters adjoining fields that seldom, if at all, discharges to receiving waters.

For the purposes of determining trash discharge ratings, Caltrans will combine the above assumptions and use a factor of forty percent (40%).

C. Five percent (5%) of trash discharges to storm drain system

A majority of Caltrans storm drain inlets have grates with 1 – 3/8" openings, preventing trash, such as bottles and cans, from entering the storm drain network. A preliminary survey of the Caltrans non-urban ROW, and the preliminary results gathered for the CDO, suggests only 2-3 percent of trash is mobilized to enter the storm drain system.

For the purposes of determining trash discharge ratings, Caltrans will use a factor of Five percent (5%).

Caltrans believes the above assumptions are reasonable to identify initial trash discharge ratings but are subject to multiple future studies as included in the TAM. Below are the calculations used to determine initial trash discharge ratings broken out by 2, 4, and 6 lane non-urban highways for greater accuracy.

4.2 Calculations

Known Constants

- 1 Cubic Yard = 200 Gallons
- 1 Mile = 5,280 Feet
- 1 Acre = 43,560 Square Feet

A. Rural Area Trash Rating Threshold Calculations:

For 2 lane highways at 30 yards/mile/year

$$\begin{aligned}
 &30 \text{ yards/mile} \\
 &\times 200 \text{ gallons/yard} \\
 &= 6,000 \text{ gallons/mile}
 \end{aligned}$$



6,000 gallons/mile
 X 40 feet average width (2 lanes +shoulders)
X 5280 feet/mile =
 6000 gallons/211,200 square feet
 X 1 acre/43,562 square feet
 = 6,000 gallons/4.85 acres

6,000 gallons/4.85 acres
X 1/4.85
 = 1,237 gallons/acres

Assuming 20% trash content = 247.4 gallons/acre
 Assuming 40% ROW connected to storm drain system = 98.96 gallons/acre
 Assuming 5.0% trash discharge potential to storm drain = 4.95 gallons/acre

B. For 4 lane highways at 60 yards/mile/year

60 yards/mile
X 200 gallons/yard =
 12,000 gallons/mile

12,000 gallons/mile
 X 80 feet average width (2 lanes +shoulders + median)
X 5280 feet/mile =
 12,000 gallons/422,400 square feet

12,000 gallons/422,400 square feet
 1 acre/43,562 square feet =
 12,000 gallons/9.7 acres

12,000 gallons/9.7 acres
 = 1,237 gallons/acres

Assuming 20% trash content = 247.4 gallons/acre
 Assuming 40% ROW connected to storm drain system = 98.96 gallons/acre
 Assuming 5.0% trash discharge potential to storm drain = 4.95 gallons/acre

C. For 6 lane highways at 80 yards/mile/year



80 yards/mile
X 200 gallons/yard
= 16,000 gallons/mile/year

16,000 gallons/mile
X 105 feet average width (3 lanes + median + shoulders)
X 5280 feet/mile =
16,000 gallons/554,400 square feet

16000 gallons/554,400 square feet
X 1 acre/43,560 square feet
= 16,000 gallons/12.73 acres
16000 gallons/12.73 acres
X 1/12.73
= 1325 gallons/acres.

Assuming 5.0% trash content and discharge potential = 5.30 gallons/acre

Table 1 is a summary of Caltrans IMMS litter production metrics in cubic yards/mile/year that have been categorized under the equivalent OVTA discharge rates resulted from the conversion assumptions and sample calculations presented above.

Table 1: Caltrans litter production compared to OVTA discharge ratings

	Low 5 gallons/acre/year	Medium 10 - 49 gallons/acre/year	High 50 - 99 gallons/acre/year	Very High 100+ gallons/acre/year
<i>Equivalent trash collection in cubic yards / mile / year</i>				
2-Lane	0 - 30	31 - 60	61 - 300	300+
4-Lane	0 - 60	61 - 120	121 - 600	600+
6-Lane	0 - 80	81 - 150	151 - 800	800+

D. To demonstrate the effectiveness of the desktop trash assessment methodology in identifying various trash ratings, Caltrans has evaluated FY 2022-23 IMMS work order data at:

- One low traffic non-urban corridors;
- One moderate traffic non-urban corridors; and
- Two high traffic non-urban corridors that include some urban segments.



Table 2 summarizes the results of the evaluation.

Table 2: Corridor Trash Ratings as Identified Through Desktop Analysis

Caltrans District	County Route	Traffic Volume	# Lanes	From	To	Total FY 22-23 Production CY/Year	CY / Mile / Year	Corridor Trash Rating
1	Hum SR-101	Low	4-6	Mendocino County Line PM* 0	Del Norte County Line PM 137	3,845	28	Low
6	Kern I-5	High	8	LA County Line PM 0	North of SR-99 Split PM 25	13,658	546	High – Very High
6	Kern I-5	High	4	SR-99 Split PM 15	King County Line PM 113	25,934	264	High
6	Kern SR-99	High	4	I-5 PM 0	Tulare PM 57	7,932	139	Moderate - High
6	Tulare SR-99	High	4	Kern PM 0	Fresno PM 50	7,213	144	Moderate - High
6	Fresno SR-99	High	4	Tulare PM 0	Madera PM 30	6,572	219	High
6	Madera SR-99	High	4	Fresno PM 0	Mariposa PM 29	1,804	62	Moderate
11	Imperial I-8	Moderate	4	San Diego County Line PM 0	Arizona State Line PM 96	2,595	27	Low

*PM = Post Mile Marker

Currently, there is variability in IMMS work orders from large scale corridor wide operations, such as comprehensive litter collection and freeway sweeping. Generally, work orders cover from about 25 -100 miles of corridor and do not differentiate between urban and non-urban segments within the corridor.

As described in attachments C and D, Caltrans is revising its current visual assessment procedures to more accurately apply to non-urban corridors. Below is a summary of these revisions:

- Refine the specificity of work orders. This entails bifurcating, to maximum extent feasible, urban and non-urban segments.
- Require separate LOS, or OVTA, visual trash assessment scores for urban and non-urban segments.



- Create a Trash Dashboard to automate IMMS trash collection work orders and visual trash assessment scores data to increase accuracy of trash ratings.

Once the Trash Dashboard is completed and the visual assessment procedures are revised and implemented, Caltrans will complete Table 2 for its entire non-urban ROW by June 30, 2026.

5. Data Used to Justify Assumptions

Caltrans has analyzed data collected from on-going studies conducted to comply with CDO. Both studies show a strong correlation between IMMS litter collection and low trash discharge rates.

A. Full Trash Capture Trash Net Data

In March of 2023, Caltrans collected the contents of Certified Full Capture nets deployed in March 2022. These nets were deployed for the purpose of accumulating data to support the Trash Discharge Study in urban areas and to comply with the CDO. Table 3 summarizes the field measurement of trash trapped in the five nets. The associated drainage areas have OVTA trash ratings and litter production characteristics that align with the thresholds established in Table 1. It should be noted that the catchment areas for these Systems are much larger than inlet-based Systems.

Table 3: Trash Net Capture Volumes & Litter Production

Trash Net ID	Caltrans District	County	Route	# Lanes	OVTA Trash Generation	IMMS Litter Production (CY/Mile/Year)	Gallons Trash Trapped	Drainage Area (Acres)	Discharge Rate (Gal/Acre/Yr)
D4 CDO Control Sites									
SWALA580 W039178	4	Alameda	580	8	Very High / High	188	10	2.09	4.78
SWALA580 EO31689	4	Alameda	580	8	Very High / High	188	1	4.61	0.25
SWALA580 W039880	4	Alameda	580	8-10	Moderate	188	3	6.20	0.48
SWALA880 S007278	4	Contra Costa	880	8-10	Moderate	146	0.25	10.07	0.02
SWALA880 S006312	4	Contra Costa	880	8-10	Moderate / High	146	13.5	5.37	0.59

3. State Water Resources Control Board Resolution 2015-0019 Amendment to the water quality control plan for oceans waters of California to control trash and part 1 trash provisions of the water quality control plan for inland surface waters, enclosed bays, and estuaries of California.



B. CDO Control Sites - Litter Production & Trash Loading

Six areas of Caltrans District 4 regulated by the CDO, and two southern California locations, were used to further correlate OVTA ratings to Caltrans litter production and the assumed OVTA trash loading as presented in the calculations in this document. Table 4 below shows a strong correlation between litter production and the “low” OVTA trash loading rating. Three of the locations support the correlation between litter production and “moderate, high, and very high” OVTA trash loading rating.

Table 4: CDO Control Sites - Litter Production & Trash Loading

Caltrans District	County	Route	# Lanes	OVTA Trash Generation	Total Miles	Litter Production (Cubic Yards / Mile / Year)	Assumed OVTA Trash Loading (Gal/Acre /Year)
D4 CDO Control Sites							
4	Napa	29	4	Low	50	29.8	0-5
4	San Mateo	1	2	Low	50	14.9	0-5
4	San Mateo	84	2	Low	30	31.9	0-5
4	Santa Clara	85	6	Moderate	25	87.4	81-150
4	Contra Costa	680	8-10	High	25	152.2	180+
4	Alameda	580	8	Very High / High	17	188.3	1600+
Unrated Rural Site Comparison							
8	San Bernadino	15	4	Unrated	110	29.8	0-5
9	Inyo / Mono	395	4	Unrated	60	21.8	0-5

6. Non-Urban Trash Studies

Caltrans shall conduct two studies related to non-urbanized highways.

A. Non-Urban Stormwater Inlet Study. Caltrans shall install Certified Full Capture Systems at;

- Twenty (20) low rated non-urban highway locations that discharge to receiving waters as identified in Table 4. Caltrans will measure the

3. State Water Resources Control Board Resolution 2015-0019 Amendment to the water quality control plan for oceans waters of California to control trash and part 1 trash provisions of the water quality control plan for inland surface waters, enclosed bays, and estuaries of California.



annual amount of trash trapped by the certified full capture system starting in 2023 over a two-year period. In addition, and

- Ten (10) low and moderate rated non-urban locations, within corridors identified in Table 6, that discharge to receiving waters and that have high traffic volumes similar to nearby urban freeways.

When selecting these locations, Caltrans will study whether there are suitable locations to install Certified Full Capture Systems that collect stormwater from multiple inlets.

The objectives of this study are to determine how much trash enters the storm drain inlets while correlating the maintenance effort to meet full trash capture equivalency. The thirty (30) locations selected were assigned trash ratings based on Caltrans IMMS records that track litter production, and in some cases OVTAs. Table 5 lists the locations that will be studied in non-urbanized areas and the associated receiving water body. The study will be conducted in accordance with the “Trash Discharge Design Study”, Attachment F of the TAM. Please refer to the Trash Discharge Design Study for site selection criteria used to determine the monitoring locations.

If the study verifies low trash ratings, it will be assumed that other low rated locations are also low. If the study does not verify the low ratings, Caltrans will enhance maintenance activities and re-do the study at the locations that resulted in a higher rating. The State and Regional Water Boards will be consulted during the studies and as data is gathered to discuss any needed adaptive management and evaluate compliance.

Table 5: Non-Urban Trash Discharge Monitoring Locations

Route	Site ID (Caltrans District-County Route)	Water Board Region	Ramp or Highway	Receiving Water Body
SR-29	D1-LAK-29S-L	5	R	Cache Creek – Clear Lake
SR-20	D1-LAK-20W-NA	5	H	Cache Creek – Indian Valley Reservoir
SR-101	D1-HUM-101N-NA1	1	H	Humboldt Bay
SR-101	D1-HUM-101S-NA	1	H	Mad River / Clam Beach
SR-101	D1-HUM-101N-NA2	1	H	Humboldt Bay
SR-29	D1-LAK-29N-NA	5	H	Lower Cache Creek – Clear Lake
I-5	D2-TEH-5N-L	5	R	Dibble Creek – Sacramento River
I-5	D2-TEH-5N-NA-1	5	H	Dibble Creek – Sacramento River
I-5	D2-TEH-5S-NA-2	5	H	Cow Creek – Sacramento River
I-5	D2-TEH-5N-L2		H	Clear Creek below Whiskytown Reservoir

3. State Water Resources Control Board Resolution 2015-0019 Amendment to the water quality control plan for oceans waters of California to control trash and part 1 trash provisions of the water quality control plan for inland surface waters, enclosed bays, and estuaries of California.



I-5	D2-TEH-5N-NA-2	5	H	Battle Creek – Sacramento River
SR-36	D2-TEH-36W-L	5	H	Battle Creek
I-5	D2-TEH-5S-NA-1	5	H	Cottonwood Creek
SR-113	D3-YOL-113N-NA	5	R	Lower Putah Creek – American River
SR-20	D3-YUB-20E-NA	5	R	Yuba River
I-70	D3-YUB-70N-NA1	5	R	Bear River – Best Slough
I-70	D3-YUB-70N-NA3	5	R	Feather River – Clark Slough
I-70	D3-YUB-70N-NA5	5	R	Yuba River
I-70	D3-YUB-70N-NA7	5	R	Big Chico Creek
I-70	D3-YUB-70N-NA9	5	R	Feather River – Lake Oroville
High Traffic Non-Urban Study Area				
SR-101	D4-SON-101-XXX	2	TBD	Estero de San Antonio
SR-101	D4-SON-101-XXX	2	TBD	Estero de San Antonio
SR-37	D4-SON-37-XXX	2	TBD	San Pablo Bay
SR-37	D4-SON-37-XXX	2	TBD	San Pablo Bay
SR-4	D4-CON-04-XXX	2,5	TBD	San Joaquin Delta
SR-4	D4-CON-04-XXX	2,5	TBD	San Joaquin Delta
SR-99	D6-FRE-99-XXX	5	TBD	San Joaquin River / Berenda Slough / Dry Creek
SR-99	D6-FRE-99-XXX	5	TBD	San Joaquin River / Berenda Slough / Dry Creek
I-8	D11-IMP-08-XXX	7	TBD	Alamo / New River
I-8	D11-IMP-08-XXX	7	TBD	Alamo / New River

B. Non-Urban Stormwater OVTA Study. Caltrans shall conduct OVTAs for 500 representative centerline miles of non-urbanized high traffic highways that have been assigned a low rating from the desktop methods presented herein.

The objectives of this study are to determine OVTA ratings and compare to initial ratings determined above. The 500 representative centerline mile segments selected were assigned low trash ratings based on Caltrans IMMS records that track litter production. Table 5 lists the locations that will be studied in non-urban OVTA Study. OVTAs will be conducted in accordance with the “Caltrans Driving On-Land Visual Trash Assessment Protocol”, Attachment C of the TAM.

The criteria used for selecting the 500 centerline mile locations are:

3. State Water Resources Control Board Resolution 2015-0019 Amendment to the water quality control plan for oceans waters of California to control trash and part 1 trash provisions of the water quality control plan for inland surface waters, enclosed bays, and estuaries of California.



- Statewide geographic distribution
- High Traffic Volumes
- Proximity to Receiving Waters
- Safety

Table 6: Non-urban OVTA Verification Sites

District / Region	County	Route	# Lanes	From	To	Miles / OVTA Segments	Average Annual Daily Traffic	Receiving Water
D2 R3	Shasta	5	4	Shasta Lake	Fisher	25 / 50	10,000 – 22,000	Trinity River
D1 R1	Mendocino / Humboldt	101	4	Ukiah	Fortuna	100 / 200	8,000 – 10,000	Russian River / Eel River
D4 R2	Sonoma	101	6	SR-37	Santa Rosa	25 / 50	80,000 – 140,000	Estero de San Antonio
D4 R2	Sonoma Napa	37	4	SR-101	SR-29	25 / 50	34,000 – 39,000	San Pablo Bay
D4, D10 R2, R5	Contra Costa	4	2	Vasco Road	I-5	25 / 50	15,000 – 30,000	San Joaquin Delta
D8 R6	San Bernadino	15	6	Barstow	State Line	100 / 200	39,000 – 49,000	Mojave / Minor Surface Waters
D9 R6	Inyo Mono	395	2	Big Pine	Sonora Junction	100 / 200	4,000 – 15,000	Bishop Creek / Owens Creek
D11 R9	Imperial	8	4	SR-79 Descanso	El Centro	100 / 200	17,000 – 23,000	Morena Reservoir / Alamo River

Note: Annual average daily traffic is the total volume for the year divided by 365 days. The traffic count year is from October 1st through September 30th. Very few locations in California are counted continuously. Traffic Counting is generally performed by electronic counting instruments moved from location throughout the State in a program of continuous traffic count sampling. The resulting counts are adjusted to an estimate of annual average daily traffic by compensating for seasonal influence, weekly variation and other variables which may be present. Annual ADT is necessary for presenting a statewide picture of traffic flow, evaluating traffic trends, computing accident rates, planning and designing highways and other purposes.

The study will result in 1,000 OVTAs. If the study verifies the low trash ratings, it will be assumed that other low rated locations are also low. If the study does not verify the low ratings, Caltrans will enhance maintenance activities and re-do the study at the locations that resulted in a higher rating. The State



and Regional Water Boards will be consulted during the studies and as data is gathered to discuss any needed adaptive management and evaluate compliance.

7. Other Studies Supporting Non-Urbanized Trash Assessment

Caltrans over the next three (3) years will survey the entire 10,000 centerline miles of non-urban ROW to identify highway segments that include curb opening inlets. Curb inlets allow trash greater than 1 and 3/8th inches to enter the inlet which may impact the trash discharge rating.

Once the curb inlets are identified and mapped, Caltrans will install ten (10) Certified Full Capture Systems at locations selected in coordination with the State and Regional Water Boards, to measure the trash entering the inlets. Depending on the results, Caltrans will assess what, if any, enhanced maintenances would be required to achieve full trash capture equivalency based on on-going trash volume measurements.

Results of this survey will inform Caltrans and State and Regional Water Boards on the prevalence of direct discharge that may warrant heightened attention. Depending on the results, Caltrans may perform enhanced maintenance and continue the measurements.

Attachment H:

Vegetation Control Study



Evaluation of Vegetation Effect on Discharge of Trash (Task Order 14)

Prepared for:

California Department of Transportation

TECHNICAL MEMORANDUM

CTSW-TM-22-379.14.1

March 2022

For individuals with sensory disabilities, this document is accessible and was prepared in compliance with California Government Code section 7405, which requires that all state agencies comply with Section 508 of the federal Rehabilitation Act of 1973.

Please call or write to:

Stormwater Liaison, Caltrans Division of Environmental Analysis, MS-27
P.O. Box 942874, Sacramento, CA 94274 0001
(916) 653 8896 Voice or dial 711 to use a relay service

Table of Contents

1	Introduction	1-1
2	Study Methodology	2-1
2.1	Siting Criteria	2-1
2.2	Site Selection.....	2-2
2.2.1	Site 1	2-4
2.2.2	Site 2.....	2-4
2.2.3	Site 3.....	2-4
2.2.4	Site 4.....	2-4
2.2.5	Site 5.....	2-5
2.2.6	Site 6.....	2-5
2.2.7	Site 7.....	2-5
2.2.8	Site 8.....	2-5
2.2.9	Site 9.....	2-6
2.2.10	Site 10.....	2-6
2.2.11	Site 11.....	2-6
2.2.12	Site 12.....	2-6
2.2.13	Site 13.....	2-7
2.2.14	Site 14.....	2-7
2.3	Full Trash Capture Devices	2-7
2.4	Site Monitoring.....	2-8
2.4.1	Data Collection.....	2-8
2.4.2	Frequency	2-9
2.4.3	Quality Assurance and Quality Control	2-9
3	Data Summary and Analysis	3-1
3.1	Rainfall Data	3-1
3.2	Trash Generation.....	3-1
3.3	Study Limitations and External Factors	3-3
3.3.1	Maintenance Activities	3-3
3.3.2	Rainfall Intensities and Amounts	3-3
3.3.3	Type of Vegetation	3-3
3.3.4	Reduced Traffic Patterns	3-3
3.3.5	Homeless Encampments	3-4
4	Potential Compliance Credit Identification	4-1
4.1	Identifying Vegetation in the ROW.....	4-1
4.1.1	Primary Classifier	4-1
4.1.2	Secondary Classifier	4-2
4.1.3	Final Classifier.....	4-3
4.2	Identifying Potential Treatment Areas.....	4-3
4.2.1	Basin Delineation	4-4
4.2.2	Flow Path Determination.....	4-6
4.2.3	Results of Identified Potential Treatment Areas	4-8
5	Conclusions and Recommendations	5-1
5.1	Additional verification of areas to claim FTCE	5-1
5.2	Litter Removal Activities – Routine Maintenance.....	5-1
5.3	Other Potential Benefits of the Data	5-1

6 References 6-1

Figures

Figure 1: Classifiers Used to Identify Vegetation in Aerial Imagery 4-2
 Figure 2: LiDAR Available in the District 4 ROW 4-4
 Figure 3: Example Delineated Basins through DEM Flow Allocation..... 4-5
 Figure 4: Visualization of Flow Paths through Vegetation 4-6
 Figure 5: Visualization of example criteria described in section 4.2.2..... 4-7
 Figure 6: Example case of criteria 1 through 3 met, but criteria 4 is not met. 4-8
 Figure 7: Measured trash generation rates and corresponding BASMAA trash generation categories..... 5-1

Tables

Table 1: Primary Site Selection Criteria 2-1
 Table 2: Site Monitoring Locations 2-3
 Table 3: Rainfall Totals vs. Historical Averages..... 3-0
 Table 4: Trash Generation Rates - Year 1 (February 2020 to January 2021)..... 3-1
 Table 5: Trash Generation Rates - Year 2 (February 2021 to January 2022)..... 3-1
 Table 6: BASMAA Trash Generation Categories and Rates 3-2
 Table 7: Caltrans D4 ROW Potential Treatment Areas by Trash Generation Rating..... 4-10

Appendices

- Appendix A: Monitoring Location Summary Sheets
- Appendix B: Trash Inlet Insert Specs
- Appendix C: Monitoring Field Form
- Appendix D: Data Summaries

1 Introduction

Caltrans is required to implement trash controls through the National Pollutant Discharge Elimination System (NPDES) Statewide Storm Water Permit Waste Discharge Requirements for the State of California Department of Transportation Order Number 2012-0011-DWQ, NPDES Number CAS000003 (NPDES Permit), which was amended by Orders WQ 2014-0006-EXEC, WQ 2014-0077-DWQ, and WQ 2015-0036-EXEC (April 7, 2015). The State Water Resources Control Board (SWRCB) adopted the Trash Amendments to address the impacts of trash on beneficial uses of surface waters. The SWRCB established an updated “conformed” permit (Conformed NPDES Permit) in March 2016. On February 13, 2019, the San Francisco Bay Regional Water Quality Control Board (RWQCB) adopted Cease and Desist Order No. R2-2019-0007 (CDO) which imposed expedited trash control measures in the San Francisco Bay Region. CDO Provision 1 requires implementation of trash controls in Moderate, High, and Very High trash generation areas by specified milestone dates as follows:

- 2,000 acres or more by June 30, 2020;
- 4,000 acres or more by June 30, 2022;
- 6,000 acres or more by June 30, 2024;
- 8,800 acres or more by June 30, 2026;
- All additional significant trash generating areas of Caltrans Right of Way (ROW) identified by visual assessments conducted in 2021, 2025, and 2029 by December 2, 2030.

Trash mitigation efforts to reach benchmarks will include both structural and non-structural controls. Structural controls, or full trash capture devices (FTCDs), are defined as a full capture treatment control or series of treatment controls that trap particles that are 5 millimeters or greater and have a design treatment capacity that is either: a) of not less than the peak flow rate, Q , resulting from a one-year, one-hour, storm in the subdrainage area, or b) appropriately sized to, and designed to carry at least the same flows as, the corresponding storm drain. Non-structural trash controls include activities such as enhanced maintenance measures (EMMs) which include street sweeping and manual litter pickups, storm drain cleaning, organized cleanup events, public education and outreach, enforcement, and existing vegetation controls.

This pilot study was initiated because trash assessment teams noticed substantial amounts of trash getting caught in vegetation and wanted to understand if the presence of vegetation prevents trash from being discharged into the storm drain system. This study evaluates whether roadside vegetation within Caltrans ROW can be successfully claimed as full trash capture equivalency (FTCE) with routine maintenance in place. The study used the trash generation categories established by the Bay Area Stormwater Management Agencies Association (BASMAA). Fourteen monitoring locations were established. Eight locations in District 4 and two locations in District 3 with a baseline classification as Moderate trash generation ratings and four additional monitoring locations in District 12 with a baseline classification as High trash generation ratings. The baseline trash generation rates in this study were from the established trash generation rates identified in the CDO.

2 Study Methodology

The study consisted of establishing siting criteria, fabrication and installation of full trash capture (FTC) devices, routine site monitoring and data collection, and coordination with Caltrans Maintenance Divisions. A total of 10 Moderate rated locations and 4 High rated locations were selected and monitored over a 2-year period, beginning in February 2020 and ending in February 2022.

2.1 Siting Criteria

Because roadside conditions vary throughout Caltrans ROW, multiple monitoring locations were sought for comparative analysis. The following criteria were considered when selecting monitoring locations for the study.

- Trash Generation Rating – All locations are within Moderate trash generating areas (Districts 3 and 4) and High trash generating areas (District 12), as identified by BASMAA's trash generation rates.
- Slope Characteristics – Slopes are categorized as either cut or fill conditions and ranged in steepness from flatter than 4:1 to between 4:1 and 2:1.
- Width of Vegetative Strip – The width of the vegetative strip is measured from the edge of pavement to the inlet. Strip widths varied from 5 feet to 10 feet, 10 feet to 20 feet, or greater than 20 feet.
- Type of Runoff Conveyance – The predominant flow regime through the vegetation to the inlet is categorized as either concentrated flow or sheet flow. Concentrated flows are experienced in locations with dikes along the edge of pavement, or drainage ditches through the vegetation. Sheet flows are experienced where runoff flows directly from edge of pavement, through vegetation, and to the inlet.
- Geographic Spread – Sites are located throughout various cities/counties within Caltrans Districts 3, 4, and 12 to provide variability in the types of vegetation and weather, namely rainfall amounts and intensities.

The following table summarizes the final site selection criteria.

Table 1: Primary Site Selection Criteria

Type	Slope Steepness	Length of Vegetative Strip	Sheet Flow / Concentrated Flow
Cut	2:1 to 4:1	5' to 10'	Sheet Flow
Cut	2:1 to 4:1	Wider than 20'	Sheet Flow
Cut	Flatter than 4:1	5' to 10'	Sheet Flow
Cut	Flatter than 4:1	Wider than 20'	Sheet Flow
Fill	Flatter than 4:1	5' to 10'	Sheet Flow
Fill	Flatter than 4:1	10' to 20'	Sheet Flow
Fill	Flatter than 4:1	5' to 10'	Concentrated Flow
Fill	Flatter than 4:1	10' to 20'	Concentrated Flow
Fill	2:1 to 4:1	5' to 10'	Concentrated Flow
Fill	2:1 to 4:1	10' to 20'	Concentrated Flow

2.2 Site Selection

Preliminary monitoring site selection was conducted through desktop research by querying only Caltrans ROW in Moderate trash generating areas throughout Districts 3 and 4 and High trash generating areas in District 12. Aerial imagery provided by Google (Google Maps) and Microsoft (Bing Maps) was reviewed to further refine the list of potential monitoring locations. Due to frequent monitoring conducted by field personnel within Caltrans ROW, safe access to and within each location was considered. Locations lacking adequate shoulder width, stabilized roadway pullout surfaces, near homeless encampments, or with other safety factors were excluded from further consideration.

Site characteristics, such as drainage area, drainage patterns, drainage infrastructure, slope steepness, and vegetative strip width were preliminarily determined using a combination of aerial imagery, Google Earth topography, and available Caltrans as-builts. Field verification of the pre-selected monitoring sites was also conducted to evaluate and document slope steepness, vegetative strip width, presence of vegetative cover, drainage area delineations, flow patterns, storm drain infrastructure, general site accessibility, and safety characteristics. A total of 14 locations were identified for inclusion in the study.

Table 2 presents a summary of the sites selected for monitoring in the study. Appendix A contains the completed siting forms for each of the monitoring locations.

Table 2: Site Monitoring Locations

Site No.	City	County	Caltrans District	RWQCB	Route/PM	Latitude	Longitude	Cut/Fill	Slope	Strip Length	Flow	Tributary Drainage Area ¹ (ac)
1	Martinez	Contra Costa	4	2	SR-4 / R5.639	38.010	-122.171	Cut	<4:1	5'-10'	Sheet	1.81
2	Martinez	Contra Costa	4	2	SR-4 / R7.464	37.996	-122.145	Cut	4:1 to 2:1	>10'	Sheet	3.36
3	San Rafael	Marin	4	2	US-101 / 13.561	38.005	-122.540	Cut	<4:1	5'-10'	Sheet	1.10
4	Oakland	Alameda	4	2	I-880 / R33.033	37.803	-122.300	Cut	<4:1	>10'	Sheet	2.73
5	West Sacramento	Yolo	3	5	I-80 / 9.082	38.573	-121.579	Fill	<4:1	5'-10'	Sheet	2.76
6	San Jose	Santa Clara	4	2	I-280 / 4.667	37.316	-121.952	Fill	<4:1	10'-20'	Sheet	1.65
7	Richmond	Contra Costa	4	2	I-580 / R2.853	37.922	-122.347	Fill	<4:1	5'-10'	Concentrated	1.18
8	Petaluma	Sonoma	4	2	US-101 / 3.723	38.234	-122.618	Fill	<4:1	10'-20'	Concentrated	2.27
9	West Sacramento	Yolo	3	5	I-80 / 9.331	38.575	-121.575	Fill	4:1 to 2:1	5'-10'	Concentrated	1.62
10	Santa Clara	Santa Clara	4	2	SR-237 / R5.763	37.415	-121.979	Fill	4:1 to 2:1	10'-20'	Concentrated	1.92
11	Buena Park	Orange	12	8	I-5 / 44.164	33.873	-118.008	Fill	4:1 to 2:1	5'-10'	Concentrated	0.85
12	Buena Park	Orange	12	8	I-5 / 40.648	33.845	-117.958	Fill	<4:1	10'-20'	Concentrated	1.44
13	Garden Grove	Orange	12	8	SR-22 / R7.924	33.769	-117.919	Fill	<4:1	10'-20;	Sheet	1.69
14	Anaheim	Orange	12	8	SR-57 / 14.885	33.840	-117.876	Fill	<4:1	5'-10'	Sheet	2.23

¹ Tributary drainage area is the entire area in acres that drains into the studied inlets.

2.2.1 Site 1

Site 1 is located along westbound State Route 4 in the city of Martinez, Contra Costa County. This stretch of highway consists of two lanes in each direction, separated by a vegetated swale. The site is a cut slope, flatter than 4:1, with a vegetative strip 5 to 10 feet wide on both sides. Vegetation consists of low to medium level grasses covering 80 to 100% of the vegetated area. Initially, four drop inlets were selected as the site's discharge points, but due to damage at the easternmost inlet, only three inlets were studied. The tributary drainage area is 1.81 acres and consists of sheet flow from the centerlines of each roadway and the vegetative strip.

2.2.2 Site 2

Site 2 is located along westbound State Route 4 in the city of Martinez, Contra Costa County. This site only features the westbound direction of traffic due to the location of storm drain infrastructure. The site is a cut slope, between 4:1 and 2:1, with a vegetative strip greater than 10 feet wide. Vegetation consists of low to medium level grasses covering 80 to 100% of the vegetated area. Initially, three drop inlets were selected as the site's discharge points, but due to unsafe access at the easternmost inlet, only two inlets were studied. The tributary drainage area is 3.36 acres and consists of sheet flow from the centerline of the westbound road and the eastern cut slope.

2.2.3 Site 3

Site 3 is located along northbound US-101 near the Freitas Parkway off-ramp in the city of San Rafael, Marin County. The site is a cut slope, flatter than 4:1, with a vegetative strip 5 to 10 feet wide. Vegetation consists of low-level grasses covering 80 to 100% of the vegetated area. During the study, it was noted that the vegetation at this site goes dormant, effectively covering less than 25% of the area. A single drop inlet was studied. The tributary drainage area is 1.10 acres and consists of the four northbound travel lanes, the roadside shoulder, and the vegetated slope.

2.2.4 Site 4

Site 4 is located along southbound Interstate 880 in the city of Oakland, Alameda County. This stretch of highway consists of four lanes in each direction, separated by a vegetated strip in the center. However, only the southbound direction of traffic was considered due to the location of storm drain infrastructure. The site is a cut slope, flatter than 4:1, with a vegetative strip greater than 10 feet in width. Vegetation consists of low-level grasses covering 80-100% of the vegetated area. Two drop inlets in the southbound median were selected as the site's discharge points. The tributary drainage area is 2.73 acres and consists of the four southbound travel lanes, the median shoulder, and the vegetated slope.

2.2.5 Site 5

Site 5 is located along eastbound Interstate 80 near the Enterprise Boulevard off-ramp in the city of West Sacramento, Yolo County. The highway expands from three lanes to five lanes at this location. The site is a fill slope, flatter than 4:1, with a vegetative strip 5 to 10 feet wide. Vegetation consists of low-level grasses covering 80 to 100% of the vegetated area. A single drop inlet located where the off-ramp and on-ramp converge was selected as the study location. The tributary drainage area is 2.76 acres and consists of the five eastbound lanes, the roadside shoulder, and the vegetated off-ramp infield area. Runoff sheet flows for 5 to 10 feet through vegetation before concentrating into a depression leading to the drop inlet.

2.2.6 Site 6

Site 6 is located along westbound Interstate 280 near the Winchester Boulevard off-ramp in the city of San Jose, Santa Clara County. This stretch of highway consists of five lanes in each direction. The site is a fill slope, flatter than 4:1, with a vegetative strip 10 to 20 feet wide. Vegetation consists of grasses, trees, and shrubs covering 80 to 100% of the vegetated area. A single drop inlet located at the westbound exit of Winchester Boulevard was selected as the study location. The tributary drainage area is 1.65 acres and consists of the two-lane off-ramp and vegetated slope.

2.2.7 Site 7

Site 7 is located along westbound Interstate 580 near the Marina Bay Parkway on-ramp in the city of Richmond, Contra Costa County. This stretch of highway consists of three lanes in each direction. The site is a fill slope, flatter than 4:1, with a vegetative strip 5 to 10 feet wide and an asphalt dike. Vegetation consists of grasses, trees, and shrubs covering 80 to 100% of the vegetated area. The single drop inlet is located within the vegetated infield area of the westbound circular on-ramp. The tributary drainage area is 1.18 acres and consists primarily of the surrounding vegetated area. A portion of the paved on-ramp drains to an inlet, then into a concrete swale, and eventually into the study inlet. The dike prevents the remaining flows from the roadway from entering the study area.

2.2.8 Site 8

Site 8 is located along northbound US-101 at the Lakeville Highway off-ramp in the city of Petaluma, Sonoma County. This stretch of highway consists of three lanes in each direction. The site is a fill slope, flatter than 4:1, with a vegetative strip 10 to 20 feet wide and an asphalt dike. Vegetation consists of grasses and trees covering 80 to 100% of the vegetated area. Two drop inlets are located in the vegetated infield area of the off-ramp. The tributary drainage area is 2.27 acres and consists primarily of the surrounding vegetated area. A portion of the paved on-ramp drains to a curb cut, then into a vegetated swale, and eventually into the study inlet. The dike prevents the remaining flows from the roadway from entering the study area.

2.2.9 Site 9

Site 9 is located along westbound Interstate 80, adjacent to the Enterprise North Park and Ride in the city of West Sacramento, Yolo County. This stretch of highway consists of six lanes in the eastbound direction and four lanes in the westbound direction. The site is a fill slope, between 4:1 and 2:1, with a vegetative strip 5 to 10 feet wide and an asphalt dike. Vegetation consists of low-level grasses covering 80 to 100% of the vegetated area. A single drop inlet is located in the vegetated area near the on-ramp. The tributary drainage area is 1.62 acres and consists of the paved on-ramp and surrounding vegetated area. Roadway runoff is conveyed along the shoulder via an asphalt dike prior to entering the vegetated area via a curb cut.

2.2.10 Site 10

Site 10 is located along eastbound State Route 237 at the Great American Parkway off-ramp in the city of Santa Clara, Santa Clara County. This stretch of highway consists of three lanes in both directions. The site is a fill slope, between 4:1 and 2:1, with a vegetative strip 10 to 20 feet wide and an asphalt dike. Vegetation consists of grasses, shrubs, and trees covering 80 to 100% of the vegetated area. A single drop inlet located at the corner of the SR-237 off-ramp and Great American Parkway was selected as the study point. The tributary drainage area is 1.92 acres and consists of the eastbound lanes along SR-237, the off-ramp, and the vegetated slope. Roadway runoff is conveyed along the shoulder via an asphalt dike prior to entering the vegetated area via a curb cut.

2.2.11 Site 11

Site 11 is located along northbound Interstate 5 at the Artesia Blvd on/off-ramp in the city of Buena Park, Orange County. This stretch of highway consists of four northbound lanes and five south bound lanes. The site is a fill section with roadside vegetation strip slopes between 2:1 and 4:1. The vegetative strip is 5 to 10 feet wide and is lined by an asphalt dike. Vegetation consists of ice plant covering about 80 to 100% of the vegetated area. A double drop inlet is located in the vegetated infield area of the off-ramp; one inlet insert was installed at this drop inlet. The tributary drainage area is 0.85 acres and consists primarily of the surrounding vegetated area. A dike prevents flows from the roadway from entering the study area from the on/off-ramps.

2.2.12 Site 12

Site 12 is located along northbound Interstate 5 at the La Palma Avenue on/off-ramp in the city of Buena Park, Orange County. This stretch of highway consists of five lanes of traffic in both directions. The site is a fill section with roadside vegetation strip slopes flatter than 4:1, with a vegetative strip 10 to 20 feet wide. Vegetation consists of ice plant covering about 80 to 100% of the vegetated area. A double drop inlet is located in the vegetated infield areas of the off-ramp, where two inlet inserts were installed. The tributary drainage area is 1.44 acres and consists of primarily surrounding vegetation and a gravel/dirt access road.

2.2.13 Site 13

Site 13 is located along westbound State Route 22 at the Harbor Boulevard on/off-ramp in the city of Garden Grove, Orange County. This stretch of highway consists of five lanes of traffic in both directions. The site is a fill section flatter than 4:1, with a vegetative strip 10 to 20 feet wide. Vegetation consists of ice plant covering 80 to 100% of the vegetated area. A single drop inlet is located in the vegetated area near the off-ramp. The tributary drainage area is 1.69 acres and consists of the paved on/off-ramp and surrounding vegetated area. Roadway runoff is conveyed along the shoulder via sheet flow prior to entering the vegetated area.

2.2.14 Site 14

Site 14 is located along northbound State Route 57 at the Lincoln Avenue on-ramp in the city of Anaheim, Orange County. This stretch of highway consists of six lanes of traffic in both directions. The site is a fill section flatter than 4:1, with a vegetative strip 5 to 10 feet wide. Vegetation consists of low-level grasses, shrubs, and trees covering 80 to 100% of the vegetated area. A single drop inlet is located in the vegetated area near the on-ramp. The tributary drainage area is 2.23 acres and consists of a portion of the paved on-ramp, part of the northbound highway lanes, and surrounding vegetated area. Roadway runoff is conveyed along the shoulder via sheet flow prior to entering the vegetated area.

2.3 Full Trash Capture Devices

Inlet catch basin inserts were selected as the FTCDs used to monitor trash accumulation in this study. Referencing the San Francisco Bay RWQCB's list of approved FTCDs, *G2 Construction, Incorporated's* Drop-In Grated Inlet Trash Screens (GITS™) were custom designed and installed at each of the monitoring location inlets. The inserts consist of a stainless-steel collection basket with 5mm perforations and are sized to meet the 1-year, 1-hour storm event. The devices are suspended within the drop inlet with the weight of the grate securing them into place. Perimeter steel panels direct all flows into the center of the receiving basket. A 6-inch opening along the top of the basket serves as an emergency overflow. The FTCDs were monitored and cleaned free of all trash and/or debris on a monthly basis to ensure full capacity at all times. Field observations verified that the emergency overflow weir was never used.

Refer to Appendix B for full device specifications.

Metal placard signage was fastened to each monitoring inlet grate to identify the study locations and alert Caltrans maintenance crews to refrain from cleaning in or around the inlets for the duration of the study. Motion detection video cameras were also installed at each monitoring location to capture trash accumulation over time. However, the cameras were subject to theft or vandalism and were discarded from use in the study.

All catch basin monitoring inserts were installed between January 13, 2020, and January 15, 2020, effectively establishing this as the commencement of trash accumulation monitoring.

2.4 Site Monitoring

Visual observations, trash collection, and maintenance monitoring were the key elements surrounding the study. Site monitoring was initially planned for a 1-year duration, aligning with the trash generation rate measurement of gallons per acre per year. However, due to statewide mandates surrounding the COVID-19 global pandemic and a below average rainfall year in 2020, the study was extended for an additional year of monitoring.

2.4.1 Data Collection

2.4.1.1 Field Monitoring Teams

Site monitoring was conducted by field monitoring teams consisting of two individuals to ensure safety and provide quality assurance and quality control (QA/QC). To reduce variability in field observations, all field personnel received both virtual and in-field training. The virtual training included review of the On-Land Visual Trash Assessment Protocol for Stormwater – Protocol C – Area Based Survey, Version 1.0 (prepared by EOA, Inc. and Keish Environmental, 2018), with a specific focus on trash categorization. Field training consisted of visiting each monitoring location as a group to review site conditions, drainage, access to the FTCDs, and safety. During this training, visual observations were baselined with all field personnel.

2.4.1.2 Inspection Activities

Within the first 10 business days of the month, crews conducted field visits to each monitoring location. Crews documented qualitative information about the overall site condition, including vegetation conditions and presence of trash in the vegetative strip. The crews then removed the inlet grate, removed trash from the inlet insert, and measured the types of trash and volume of trash captured by the inlet inserts. If trash was present in the insert, the types of trash were further broken down into percentages. The crews also made note of any indications that maintenance had been completed recently. Less trash in the strip than the previous visit, Caltrans or Adopt-A-Highway trash bags on site ready for pick up, and trimmed vegetation were all indicators that maintenance had recently occurred.

2.4.1.3 Field Form

A Field Form template was developed to assist monitoring personnel with data collection. The form was organized into the following sections:

- General Site Information
- Maintenance Information
- Storm Event Data
- Vegetation Observations
- Discharge Observations
- Trash Observations
- Photographic Documentation

A copy of the Field Form template is included in Appendix C.

2.4.1.4 Litter Removal Activities by Maintenance Division

Routine sweeping, vegetation management, and litter pickups contribute to the maintenance items described in the study. Maintenance is typically conducted by Caltrans maintenance crews, the Caltrans' Adopt-A-Highway Program, or special crews (parolee or veteran). The intent of the study was to measure trash discharge generation rates from study areas without changing litter removal practices – maintaining the types or frequencies of activities. Per discussions with maintenance staff it was determined that maintenance schedules occur on a rolling, as-needed basis, meaning they are not conducted with a prescribed frequency like a city street-sweeping program. As a result, maintenance activities during the study were tracked by field teams through visual observations made during monitoring events. Site maintenance was assumed to have occurred during the previous month when filled trash bags were on site, visible changes to vegetation had been made, or when there was a clear reduction in the amount of trash in the study area.

As described in section 5.2, a review of Caltrans' Integrated Maintenance Management System (IMMS) data is a recommended future step to verify when litter removal activities were performed during the study.

2.4.1.5 Storm Event Data and Rainfall Totals

During this study a summary of all storm events that occurred during the reporting period was compiled. This included recordkeeping of storm durations, individual storm intensities, rainfall totals, and monthly totals. Rainfall data were obtained from the nearest National Oceanic and Atmospheric Administration (NOAA) rain gauge.

2.4.2 Frequency

Visual site monitoring was conducted on a monthly basis within the first 10 business days of the month. Monitoring at Sites 1-10 began in March 2020, approximately 1.5 months after FTCDs had been installed. As previously described, statewide mandates surrounding COVID-19 limited the availability of monitoring. All monitoring efforts were temporarily suspended from April 2020 to May 2020. While this gap deviated from the original frequency set, data obtained once monitoring resumed were determined to be unaffected as site conditions had not changed during this period. Site monitoring was conducted for a total of 24 months at Sites 1-10, ending in February 2022.

Monitoring at Site 11-14 began in July 2020. Site monitoring was conducted for a total of 19 months at Sites 11-14, ending in February 2022.

2.4.3 Quality Assurance and Quality Control

To ensure consistency in visual observations and reporting, multiple QA/QC measures were implemented. All field monitoring was conducted in teams of two, allowing discussion and confirmation of all observations. Monitoring crews were also assigned to the same site locations throughout the duration of the study to provide consistency in observations. Upon completion of field data collection, all inspection reports and photos were reviewed by an independent individual. Any discrepancies in reported observations were then discussed with field personnel for verification and agreement. As a final check, 1-2 site monitoring forms were audited by a second, independent individual for confirmation of data on a monthly basis.

3 Data Summary and Analysis

3.1 Rainfall Data

Rainfall data were obtained to determine if a correlation exists between amount of rain received and trash discharged. Table 3 summarizes the annual rainfall totals at each monitoring location, based on the nearest NOAA weather station. The 10-year average rainfall was selected from data obtained between 2011 and 2020 at the same weather stations. The data confirm a significantly lower rainfall year in 2020. The 2021 rainfall totals appear to be more in line with the historical averages at most monitoring locations.

Table 3: Rainfall Totals vs. Historical Averages

	Site													
	1	2	3	4	5	6	7	8	9	10	11	12	13	14
NOAA Rain Gauge	KCCR	KCCR	KOAK	KOAK	KSAC	KSJC	KOAK	KDVO	KSAC	KSJC	KSNA	KSNA	KSNA	KSNA
Distance to Site (mi)	6.3	4.8	26.7	7.9	6.1	3.4	16.1	7.2	5.9	4.6	14.9	12.8	7.2	11.3
Rainfall Total (in)														
<i>Historical Yearly Average (2010-2020)</i>	19.41	19.41	25.19	19.68	17.38	25.6	19.68	25.19	17.38	25.6	10.09	10.09	10.09	10.09
2020	4.29	4.29	5.82	5.82	5.61	5.14	5.82	9.11	5.61	5.14	6.75	6.75	6.75	6.75
2021	8.95	8.95	20.93	20.93	18.59	5.34	20.93	29.15	18.59	5.34	8.78	8.78	8.78	8.78
2022 (Jan only)	0	0	0.25	0.25	0.05	2.81	0.25	0.61	0.05	2.81	0.06	0.06	0.06	0.06

3.2 Trash Generation

Trash generation is calculated as the yearly volume (gallons) of trash captured in the FTCD divided by the total drainage area. Tables 4 and 5 present the trash generation rates for each year of the study.

Table 4: Trash Generation Rates - Year 1 (February 2020 to January 2021)

Site	Trash observed in inlet inserts (gallons)	Total Drainage Area (acres)	Trash generated (gallons/acre/year)
1	0.47	1.81	0.26
2	0.93	3.36	0.28
3	3.71	1.10	3.37
4	3.27	2.73	1.20
5	1.25	2.76	0.45
6	1.15	1.65	0.70
7	4.39	1.18	3.73
8	0.00	2.27	0.00
9	0.95	1.62	0.59
10	0.46	1.92	0.24
11*	0.00	0.85	0.00
12*	0.25	1.44	0.17
13*	0.02	1.69	0.01
14*	0.77	2.23	0.34

*Sites 11-14 were added to the study in July 2020. The sites were monitored for a total of 9 months in Year 1.

Table 5: Trash Generation Rates - Year 2 (February 2021 to January 2022)

Site	Trash observed in inlet inserts (gallons)	Total Drainage Area (acres)	Trash generated (gallons/acre/year)
1	0.06	1.81	0.03
2	0.52	3.36	0.15
3	0.85	1.10	0.77
4	2.96	2.73	1.08
5	0.23	2.76	0.08
6	0.01	1.65	0.01
7	0.10	1.18	0.08

Site	Trash observed in inlet inserts (gallons)	Total Drainage Area (acres)	Trash generated (gallons/acre/year)
8	0.00	2.27	0.00
9	0.12	1.62	0.07
10	0.30	1.92	0.16
11	0.00	0.85	0.00
12	0.50	1.44	0.35
13	0.10	1.69	0.06
14	0.42	2.23	0.19

As demonstrated in Tables 4 and 5, the trash generation rates for all monitoring locations were below 5 gallons/acre/year for each of the two years monitored. Site 7 in 2020 was the sole location to approach the 5 gallon/acre/year threshold. All remaining sites were well below the Low trash generation rate designation, indicating that roadside vegetation is effective at reducing trash loads to waterways.

Table 6: BASMAA Trash Generation Categories and Rates

Category	Low	Moderate	High	Very High
Generation Rate (gallons/acre/year)	< 5	5-10	10-50	50-150

Additional data metrics are presented in Appendix D. These items include trash discharge correlations with rainfall amount, percent of vegetative cover, and frequency of maintenance.

3.3 Study Limitations and External Factors

The study was conducted over a period of 2 years to obtain a large data sample and to minimize factors that may cause variability in the results. Additionally, a few data limitations should be considered. The following sections describe potential limitations and unforeseen factors, as well as their perceived impact on the results.

3.3.1 Maintenance Activities

A large component of this study was to correlate trash generation rates with Caltrans maintenance operations. However, coordination with maintenance divisions was limited. To document when maintenance had occurred at a given site, visual observations of vegetation condition and trash volume were made. When a noticeable change in either criteria was noted between 2 months, or when filled trash bags were present on site, it was assumed that maintenance had occurred during the previous month. Based on these observations, increasing maintenance activities will have no impact on trash discharge in moderate STGAs.

3.3.2 Rainfall Intensities and Amounts

It was assumed that rainfall intensity and total rainfall amount may have the potential to affect trash generation rates. Data from NOAA suggest that storm events may be shorter or less frequent but have higher intensities when compared with historical averages. Rainfall totals in 2020 were considerably lower than the last 10-year historical average. Rainfall totals in 2021 were more in alignment with the averages. Trash generation rates appear not to have been significantly affected by the variation in rainfall patterns.

3.3.3 Type of Vegetation

While all sites monitored in Districts 3 and 4 consisted of low-level grasses and perennial ice plant in District 12, vegetation types were not directly analyzed. There is the potential for certain types of vegetation to better capture trash than others. The percent of vegetative cover was observed and considered, but it appears not to have significantly affected trash generation rates.

3.3.4 Reduced Traffic Patterns

Statewide mandates surrounding COVID-19 may have affected roadside trash accumulation due to reduced traffic rates. While data on traffic impacts have not been analyzed for this study, it is likely that fewer vehicle trips were made during the early part of the pandemic. However, the data from this study show a decrease in trash generation rates in Year 2, after traffic patterns were likely more normalized.

3.3.5 Homeless Encampments

Caltrans ROW in and around urban centers is susceptible to transient movement and occasionally full encampments. This scenario was encountered at Site 7 in the city of Richmond. A homeless encampment was present from the period of June 2020 to January 2021. During this time, a significant increase in trash was observed throughout the study area, in addition to degradation to the surrounding vegetation. Originally observed to be designated as a Moderate trash generating area, the site likely transitioned to a High trash generating area during this time. The FTCD at this site captured 4.39 gallons of trash during this period. The total trash captured over the 2-year study was 4.49 gallons.

4 Potential Compliance Credit Identification

This section describes the methodology used for identifying similar sites in Caltrans ROW that are representative of the pilot study sites for potential compliance credit. Areas were largely calculated using a semi-automated and supervised fashion leveraging best available spatial information and aerial imagery. Identifying areas of potential compliance credit via flow through vegetation requires knowledge of the following items:

1. Where vegetation occurs in the ROW
2. How surface water flows throughout the ROW
3. The quantity and location of trash that is generated in the ROW
4. The location of the storm inlets in the ROW that receive surface water runoff

Identification of potential compliance credit begins with identifying where vegetation exists in the ROW and identifying tributary drainage areas. The processes described were performed on a District-wide scale to assist in identifying where potential credit exists. Verification of sites will be required before credit can be claimed.

4.1 Identifying Vegetation in the ROW

Multiple approaches and automated processes were tested in an effort to select the best large-scale methodology for classifying vegetation in the ROW. Methods were tested iteratively and compared against one another as well as manual efforts. Each method utilized National Agriculture Imagery Program (NAIP) aerial imagery collected in 2020 and these included manual thresholding, vegetation indices, and a machine learning model. The most current 4-band NAIP imagery was selected as the classification input dataset because it was recently collected, is high resolution (0.6 meter), and contains a near-infrared band in addition to the visible red, green, and blue bands. The near-infrared band contains important information used to identify areas where vegetation is likely. It is widely used in scientific literature to calculate important vegetation indices such as the Normalized Difference Vegetation Index (NDVI), which is correlated to the presence of vegetation.

To identify where vegetation occurs in the ROW, a series of classifiers were developed that identify and process information from an aerial image. The final classification workflow is illustrated in **Error! Reference source not found.** and described in the three steps below.

4.1.1 Primary Classifier

The first step was to initially classify every area of the ROW at a high resolution. Specifically, each 0.6-meter pixel of the aerial image received a classification. This type of image classification is known as semantic segmentation or pixel classification. The employed classifier is termed a random forest classifier, which a type of machine learning model. This project model classified pixels into the following three categories:

1. Vegetation
2. Shadow
3. Neither vegetation nor shadow (the remainder of the ROW)
This largely included pavement, buildings, vehicles, storage tanks, etc.

Classifying pixels as “Shadow” was a necessary due to the absence of detail in the darker shaded areas of the aerial imagery, preventing the model from making an accurate classification of vegetation or non-vegetation.

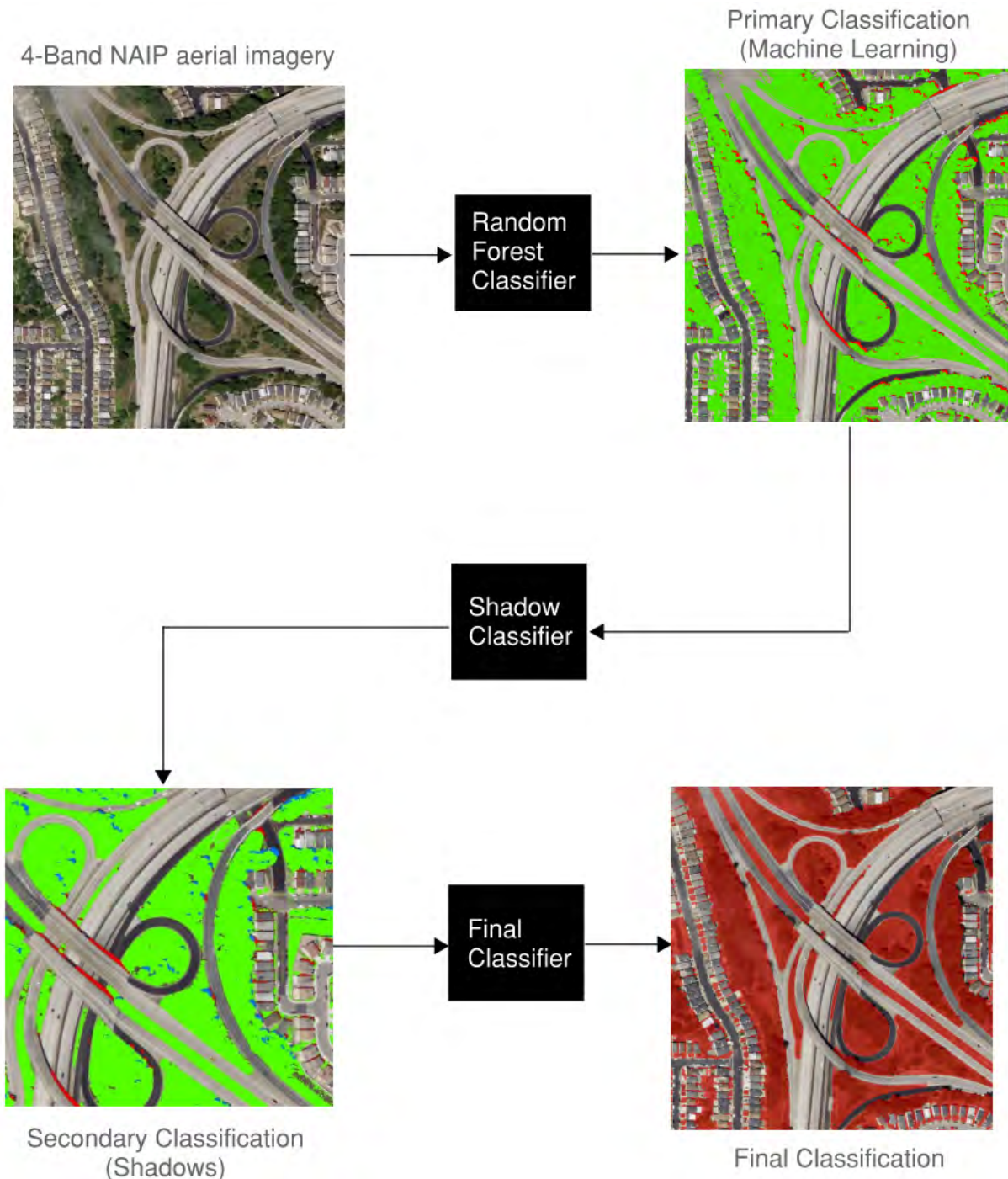

Figure 1: Classifiers Used to Identify Vegetation in Aerial Imagery

4.1.2 Secondary Classifier

A secondary classifier is then run on the result of the primary classification to further classify the shaded regions into:

1. Shaded vegetation
2. Shaded and not vegetation

This process uses the pixels surrounding the shaded area to inform whether it is likely shaded vegetation or shaded and not vegetation.

4.1.3 Final Classifier

Once all pixels are classified as either vegetation or not vegetation, the final classification occurs via post-processing routines to combine the “shaded vegetation” with “vegetation” and “shaded non-vegetation” with “non-vegetation”. Small imperfections or holes are also corrected to produce a final raster with only two classifications of vegetated and not vegetated.

From this final raster, polygons were exported and smoothed to create a shapefile that covers vegetated areas and could be used for spatial analysis. Approximately 12,500 acres of vegetation were identified, representing about 42% of the total ROW area. With the vegetation identified, the next step was to delineate drainage basins and evaluate flow paths through vegetation and into storm drains, as described next.

Notes and assumptions inherent to the vegetation analysis include:

1. Vegetation does not significantly vary seasonally and the most recent NAIP aerial imagery is an accurate depiction of the existing vegetated areas.
2. No distinction is made between the types of vegetation.
3. Vegetation beneath objects, such as overpasses, is obscured in the orthoimagery and was not classified as vegetation.

4.2 Identifying Potential Treatment Areas

Individual drainage basins within the ROW were delineated from digital elevation models (DEMs). These were built from the most recently collected and highest resolution publicly available Light Detection and Ranging (LiDAR)-derived terrain datasets. The resolution varied across the District 4 ROW depending on the associated LiDAR collection, as shown in Figure 2. One-meter resolution data collected between 2016 and 2020 were available in most of the ROW. The central bay area had 3-meter resolution data collected between 2006 and 2010, while a small section of ROW in the southwest was limited to coarse 30-meter resolution data. This automated DEM-based analysis was not feasible with 30-meter resolution data, and so was focused on the remainder of the ROW with 1-meter and 3-meter coverage.



Figure 2. LiDAR Available in the District 4 ROW

4.2.1 Basin Delineation

Using the best available LiDAR-derived DEMs, basins were delineated inside the ROW using standard hydrologic conditioning methods to allocate flow in all areas of the DEM to drain either to a known inlet location or out of the ROW (illustrated in Figure 3).

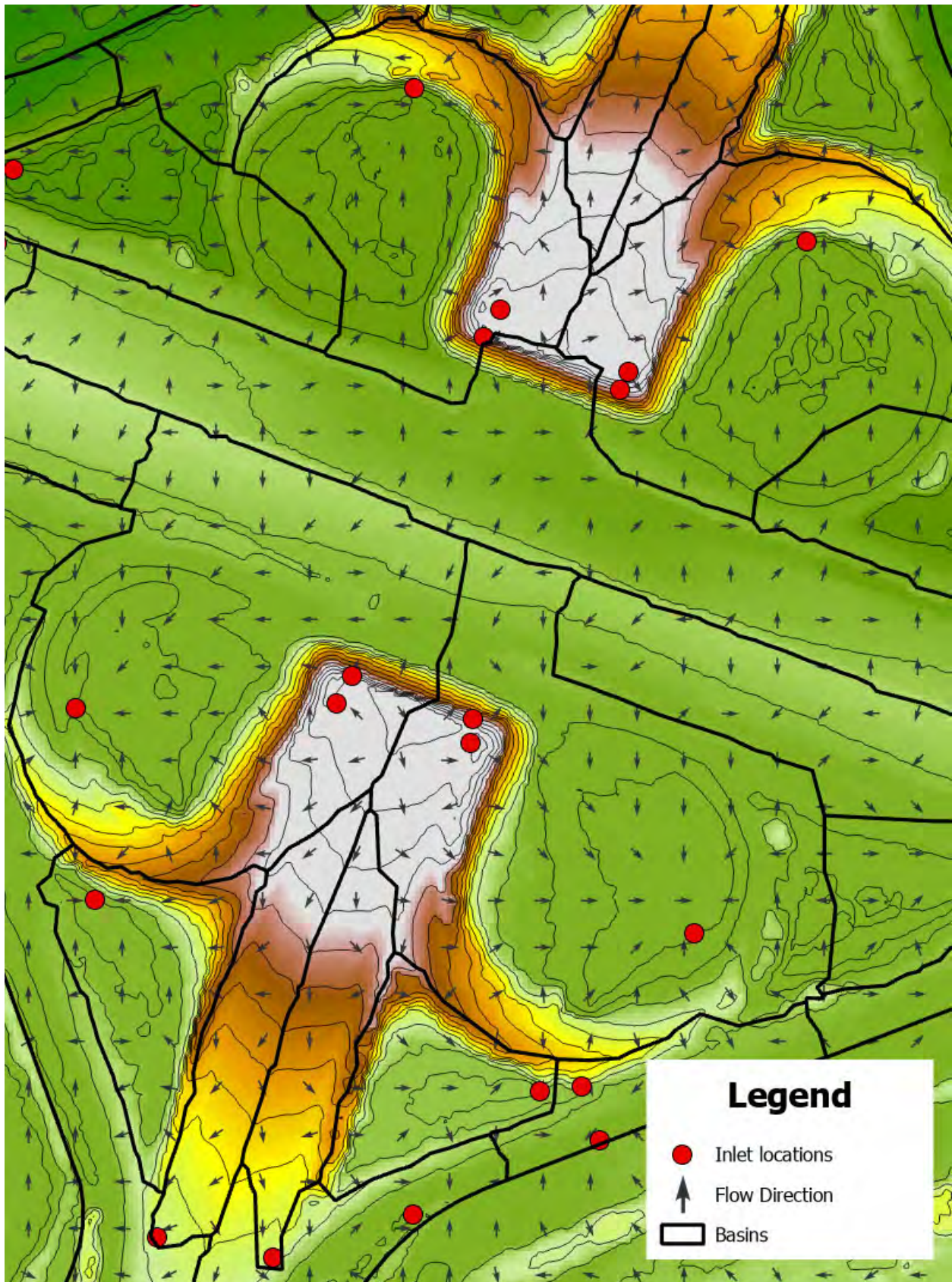

Figure 3: Example Delineated Basins through DEM Flow Allocation

4.2.2 Flow Path Determination

Using the flow directions generated in the previous step, flow paths can be determined for each area in the ROW. The flow paths were then combined with the vegetation layer to produce a flow-through-vegetation layer. This layer describes the amount of vegetation at each point in the ROW that water travels through on its way to an inlet. This is visualized in Figure 4 where the colors represent the cumulative flow length through vegetation in the flow path at each point.

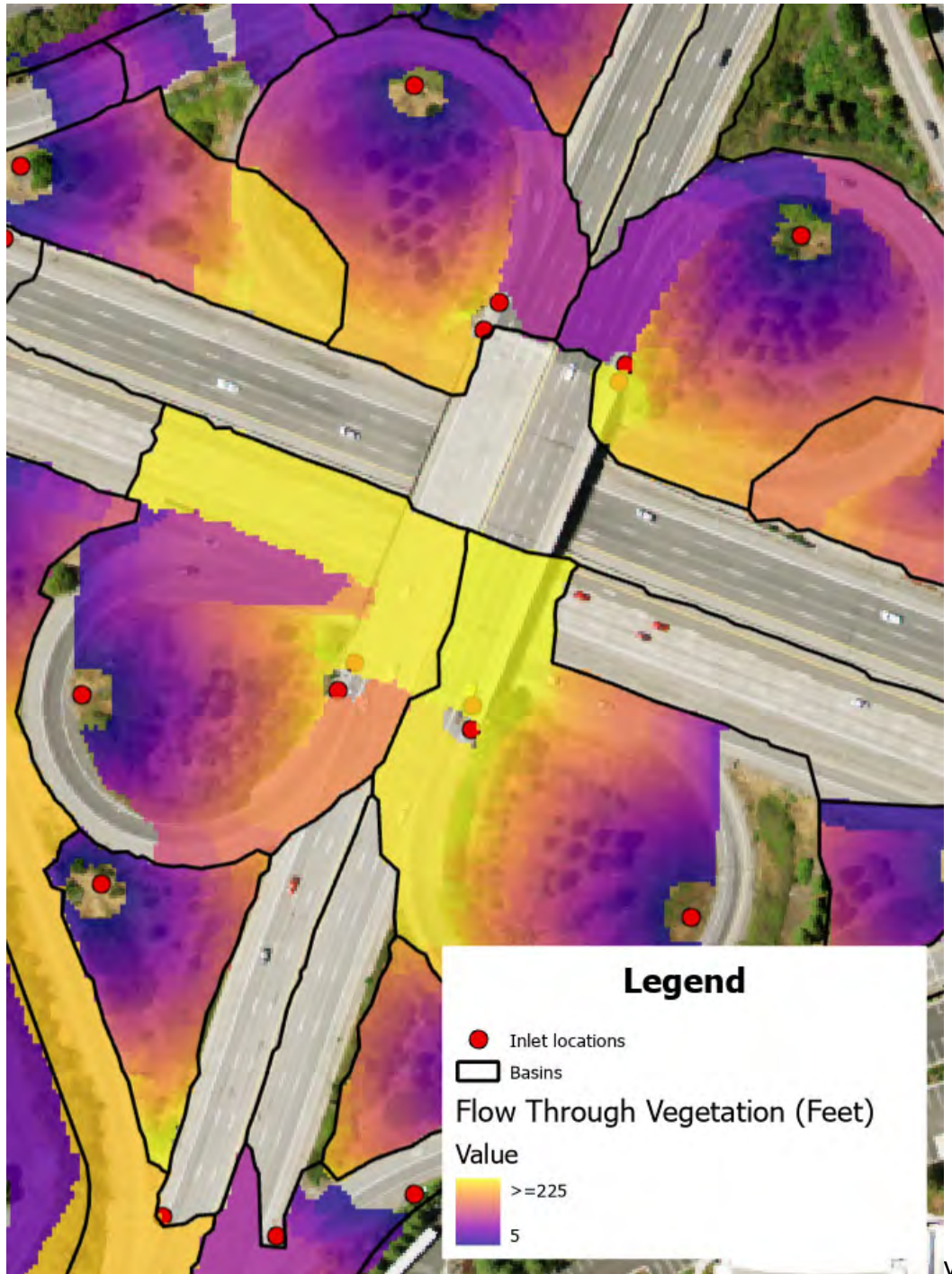

Figure 4: Visualization of Flow Paths through Vegetation

There are multiple ways of defining treated areas. The areas that met the following criteria were analyzed:

1. All areas that drain through a minimum length of vegetation (e.g., flow of water passes through at least 5 feet of vegetation in any portion of the flow path. Flow does not necessarily need to enter an inlet inside or outside of the ROW).
2. All areas that drain through minimum lengths of vegetation in any portion of the flow path and also drain to an inlet within Caltrans ROW. Flow can drain outside of Caltrans ROW and back inside of a Caltrans ROW boundary.
3. All areas that drain through a minimum length of vegetation, drain into an inlet, and the flow path never exits Caltrans ROW boundary.
4. All areas that drain through a minimum length of vegetation immediately preceding the inlet (i.e., the inlet itself is located within a vegetated area and not just some part of its contributing basin).

The results presented in Section 4.2.3 reflect the most stringent criteria (i.e., criteria 4) using a minimum vegetation length of 5 feet.

Criteria 1 contains all areas in criteria 2, criteria 2 contains all areas in criteria 3, and criteria 3 contains all areas in criteria 4. Figure 5 and Figure 6 below show some example flow paths that pass through significant vegetation and meet the criteria listed above. The ROW boundary is shown in black and flow paths are approximately drawn in for visualization purposes only.

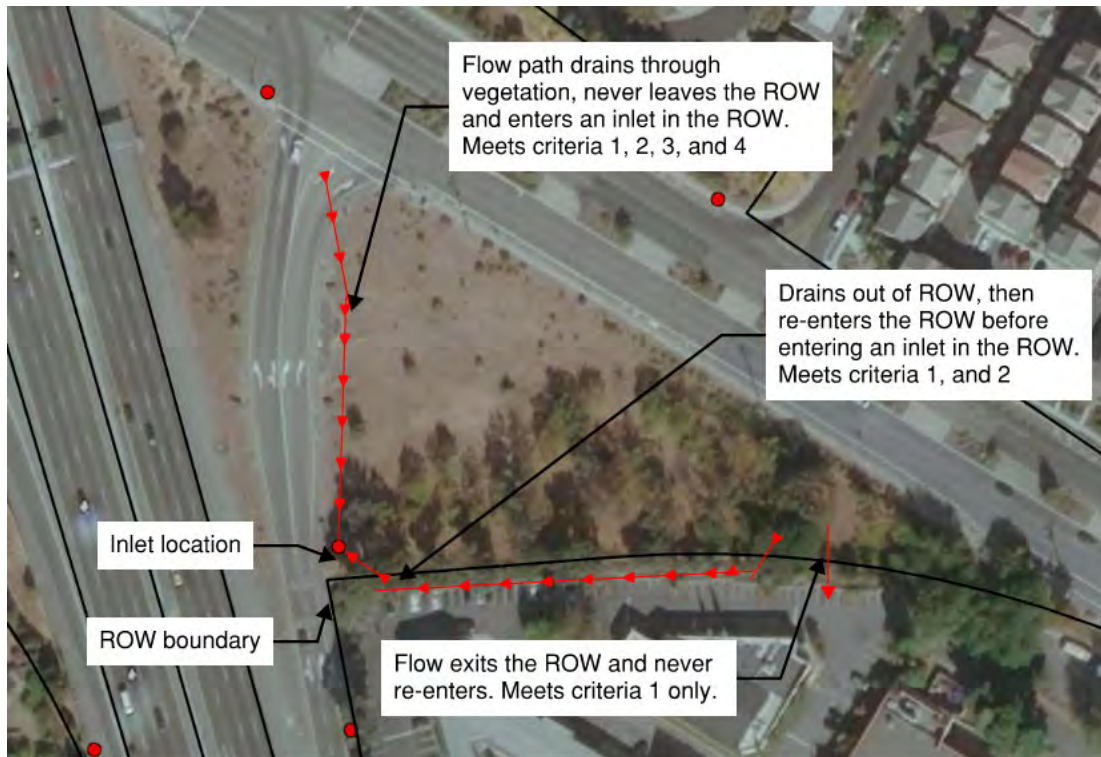

Figure 5: Visualization of example criteria described in section 4.2.2.

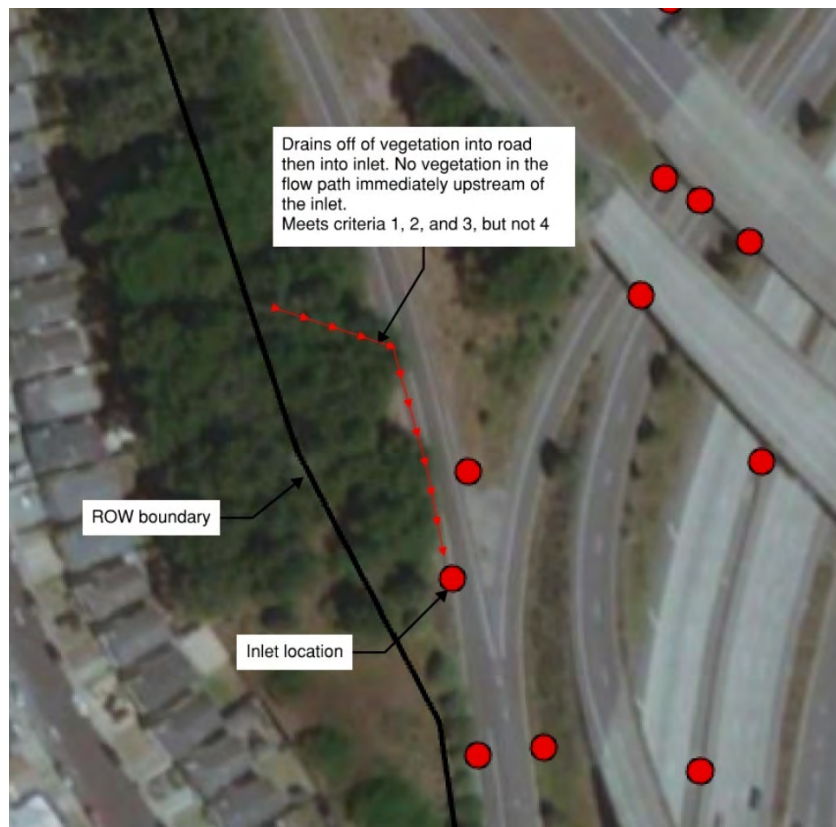

Figure 6: Example case of criteria 1 through 3 met, but criteria 4 is not met.

Notes and assumptions inherent to basin delineation include:

1. 1-meter and 3-meter resolution data are detailed enough to capture important features that impact flow paths, such as curb and gutter.
2. Drainage over and around elevated structures, such as buildings and bridges, is not accounted for. Flow paths are computed over a hydrologically conditioned DEM derived from LiDAR with building footprints and bridge crossings removed.
3. Trash is transported within the ROW predominantly in the same direction that surface water would drain.

4.2.3 Results of Identified Potential Treatment Areas

Potential treatment areas were computed for all basins in Caltrans District 4 ROW with resulting acreages tabulated by assigned trash generation rating (see

Table 7). The baseline trash generation rates in this study were from the established trash generation rates identified in the CDO. The percentages in the table do not add up to 100%, but rather, they represent the proportion of Caltrans ROW that falls into each category for perspective.

Table 7: Caltrans D4 ROW Potential Treatment Areas by Trash Generation Rating

Flow Length Through Vegetation Prior to Inlet ² (feet)	Unrated Acres	Mixed Rated Area Acres	Low Acres	Moderate Acres	High/Very High Acres
>5	37 (24%)	910 (22%)	3100 (17%)	1500 (20%)	260 (21%)
>10	35 (23%)	850 (21%)	2900 (16%)	1400 (19%)	230 (19%)
>15	32 (21%)	810 (20%)	2700 (15%)	1300 (18%)	220 (18%)
>20	31(21%)	750 (18%)	2600 (14%)	1200 (17%)	220 (17%)
All Vegetated areas within Caltrans ROW Area	75 (50%)	1500 (36%)	8000 (43%)	2600 (36%)	470 (38%)

Within moderate trash generation areas in the ROW, the analysis predicts that there are approximately 1,500 acres of potential compliance credit if 5 feet of vegetation prior to an inlet is considered for effective treatment. This represents approximately 20% of the 7,200 acres of moderate trash generation-rated acreage in District 4 ROW. Unrated and Mixed Rated Areas represent intersection areas and new ramps discovered that do not have trash generation ratings yet. These areas without a clear trash rating designation are flagged for resolution in the next assessment performed.

² Each row in this table describes the minimum flow path through vegetation. For example, greater than 5 feet includes all flow lengths greater than 10, 15, and 20 feet. It means that flow passes through at least 5 or more feet of vegetation immediately prior to discharging into an inlet.

5 Conclusions and Recommendations

The findings of this study demonstrate that vegetation within Caltrans ROW can be successfully claimed as FTCE. This conclusion is based on the measured trash generation rates from all study areas, which all fall within the Low trash generation category with a rate of 0 to 5 gallons of trash generated per acre per year (see Figure 7). As a result, it is recommended that Moderate-rated areas with similar vegetation and drainage characteristics (potentially 1500 acres) be considered FTCE because their measured volume of discharge is equivalent to low trash generating areas. Areas for credit are pending the completion of additional quality assurance/quality control steps – discussed in section 5.1 – to verify the defensibility of re-classification.

Site	Trash generation rating	Trash generated (gallons/acre/year)
1	Moderate	0.15
2	Moderate	0.22
3	Moderate	2.07
4	Moderate	1.14
5	Moderate	0.27
6	Moderate	0.35
7	Moderate	1.91
8	Moderate	0.00
9	Moderate	0.33
10	Moderate	0.20
11	High	0.00
12	High	0.26
13	High	0.04
14	High	0.27

Category	Low	Moderate	High	Very High
Trash Generation Rate (gallons/acre yr ⁻¹)	2.5 (0-5)	7.5 (5-10)	30 (10-50)	100 (50-150)

Figure 7: Measured trash generation rates and corresponding BASMAA trash generation categories

5.1 Additional verification of areas to claim FTCE

Additional quality assurance/quality control steps are recommended to verify the validity and defensibility of claiming FTCE for vegetated areas. As described in section 4, vegetated areas in the ROW and delineated treatment sheds that pass-through vegetation immediately before entering an inlet have been identified using GIS analysis. Recommended verifications steps include:

1. Confirmation that identified treatment sheds were correctly delineated by the GIS analysis.
2. Verification of hydraulic connections to confirm the flow of water goes through vegetation immediately preceding the inlet.
3. Identification and removal of overlaps with areas already treated by FTCDs installed on Caltrans ROW or installed in municipal ROW-treated portions of Caltrans ROW.

Once the above steps are completed, the finalized drainage area delineations will be mapped in a GIS database.

5.2 Litter Removal Activities – Routine Maintenance

As noted in section 2.4.1.4, it is recommended that IMMS data be reviewed to better understand how litter removal activities were performed during the pilot study. Comparing this data with the visual observations recorded by field monitoring teams will verify the frequency of activities and evaluate the record-keeping potential of IMMS when it comes to documenting litter removal activities that contribute to compliance efforts.

A pre-requisite for claiming FTCE is the sustained implementation of routine litter removal maintenance practices, which include litter pickups and street sweeping. Caltrans must document and report these routine practices to ensure the re-classification of moderate areas is sustained. The documentation can be achieved through activity tracking through Caltrans' IMMS or the creation of a new tracking and reporting system. IMMS is a management system that allows the Maintenance Division to effectively plan, perform, and manage maintenance work. It is recommended Caltrans complete a thorough evaluation of the record-keeping processes of IMMS to understand the system's role in documenting routine litter removal practices, as well as identifying necessary changes to the system or data inputting processes.

5.3 Other Potential Benefits of the Data

The analyses and datasets generated by this study have great potential to be of further use to Caltrans. Examples of other areas of study or additional applications include:

- Vegetated drainage areas that sheet flow off the ROW without draining to an inlet were also delineated as part of the potential credit identification process described in section 4. These areas may also qualify for FTCE pending further study and/or analysis.

- Treatment sheds that drain out of Caltrans ROW to municipal ROW – i.e. local connection points - were identified as a by-product of the basin delineation process. This data could be used to identify additional municipal coordination projects.
- Basin delineation processes using LiDAR data may dramatically assist with planning-level pollutant reduction feasibility studies. Similar analyses can be completed in any area of Caltrans ROW with a ROW boundary delineation, inlet location data, and LiDAR data.
- Vegetation identification datasets can be used to generate more accurate planning level calculations of impervious and pervious acreages in Caltrans ROW. These datasets can be developed in an area of Caltrans ROW with a ROW boundary delineation and NAIP imagery.
- All analyses and calculations completed in this study can be expanded to a statewide level pending the availability of ROW boundary, vegetation, and DEM datasets.

6 References

Caltrans. "Driving On-Land Visual Assessment Protocol," September 2018.

Caltrans. "Maintenance Manual." July 2014. Accessed at <https://dot.ca.gov/programs/maintenance/maintenance-manual>.

EOA, Inc. On-land Visual Trash Assessment Protocol for Stormwater. Protocol B - Driving Survey, Establishing baseline levels of trash generation and assessing changes in trash levels. Version 2.0, March 2018.

EOA, Inc. "Tracking California's Trash Project." Bay Area Stormwater Management Agencies Association December 2016.

Appendix A: Monitoring Location Summary Sheets

Evaluation of Vegetation Effect on Discharge of Trash

Contract 43A0379, Task Order #14

Site Selection

GENERAL SITE INFORMATION: 1.1

District: 4	RWQCB: 2	City: Martinez	County: Contra Costa
Location: 38.009937°, -122.170580°		Route/PM: John Muir Pkwy (Route 4) / CC R5.693	
Type of system: (Type 1) Cut section with vegetation strip slope flatter than 4:1 (with vegetation strip 5'-10')			
Type of vegetation: Medium/Low lying grasses, recently maintained.		Vegetation cover: 80-100%	
Tributary Drainage Area: 1.83 Acres (79,739 sq*ft)			

SITE EXHIBIT:

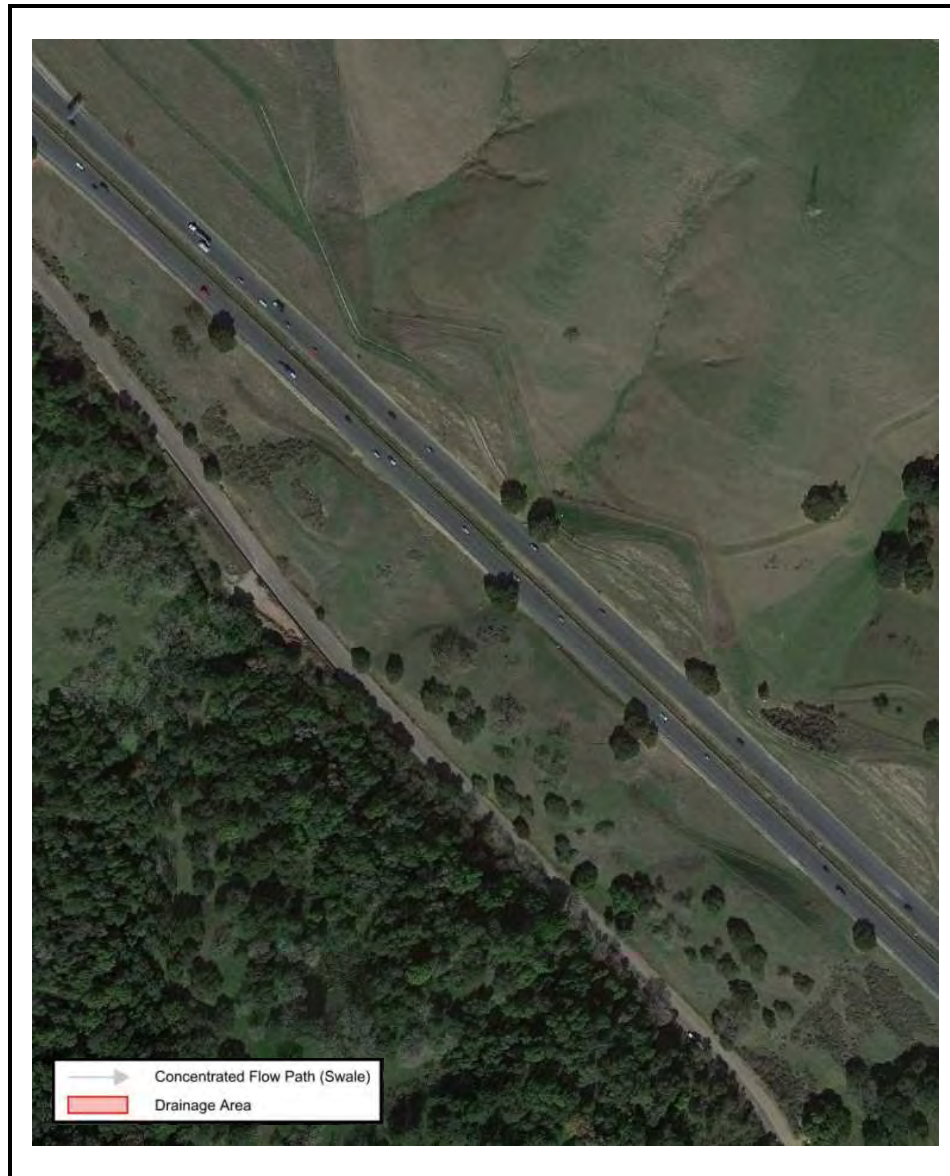

Evaluation of Vegetation Effect on Discharge of Trash

Contract 43A0379, Task Order #14

Site Selection

GENERAL NOTES: Site is within a Moderate Trash Generating Zone (Highway)

Safety Concerns:

- Accessing the proposed project site (1.1) was not observed to be a safety concern.
 - Project site is located in the center median and is accessed from the left most lane (fast lane).
 - Project location is along a straight away and has good visibility from the road for oncoming traffic.
 - Parking in the shoulder is adequate with a buffer from roadway.
 - Vehicles can pull into the swale to be further shielded from traffic.
 - Guard rail along the south bound direction shields vehicles.
- Ponding is not anticipated to be a concern.
 - Any ponding water will bypassing the proposed trash capture device and be conveyed to the downstream inlet, approximately 150' to the northeast .

Site Access Details:

- Project site can be accessed from John Muir Parkway (Hwy 4) east, 0.5 miles from the Mc Ewen East onramp.
 - Project site is located in the center median and is accessed from the left most lane (fast lane).
 - Parking in the shoulder is adequate with a buffer from roadway.
 - Vehicles can pull into the swale to be further shielded from traffic.
 - Site cannot be access from west bound direction due to guard rail
 - Three (3) inlets are located along a 0.3-mile straight roadway section, sloped within the same to drain to the northwest.

Security Concerns:

- Is the site subject to vandalism or theft? Yes No
 - Describe: No vandalism or theft concerns. Inlet insert is subsurface.
- Is the site subject to other damage? (e.g., errant drivers)? Yes No
 - Describe: No preliminary concern over damage. Inlet insert is subsurface.

Maintenance Considerations:

- Project site (1.1) was recently maintained.
 - Little to no trash observed in strip or swale.
 - Vegetation was recently mowed.

Proposed Monitoring Device:

- Three (3) catch basin inserts are recommended, one at each proposed drop inlet.
 - An approved Caltrans full trash capture catch basin inert is recommended.
- Total volume of trash will be summed from all trash capture devices.

Sample Drawings: G2 GITS™ for Inlets with Grates

Certified Full Capture Systems – California State Water Board

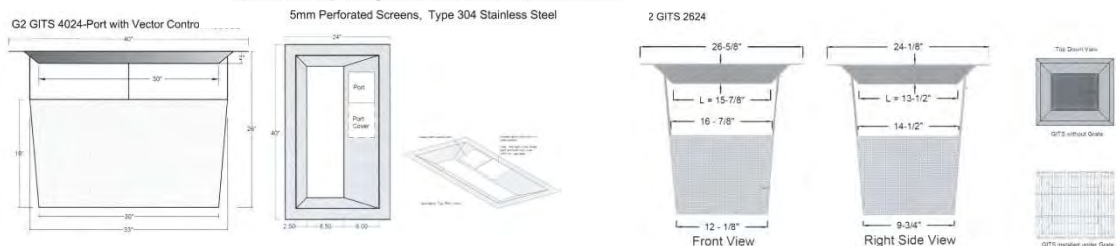



PHOTO A: VEGATED STRIP AND SWALE – DOWNSTREAM (SOUTHEAST)

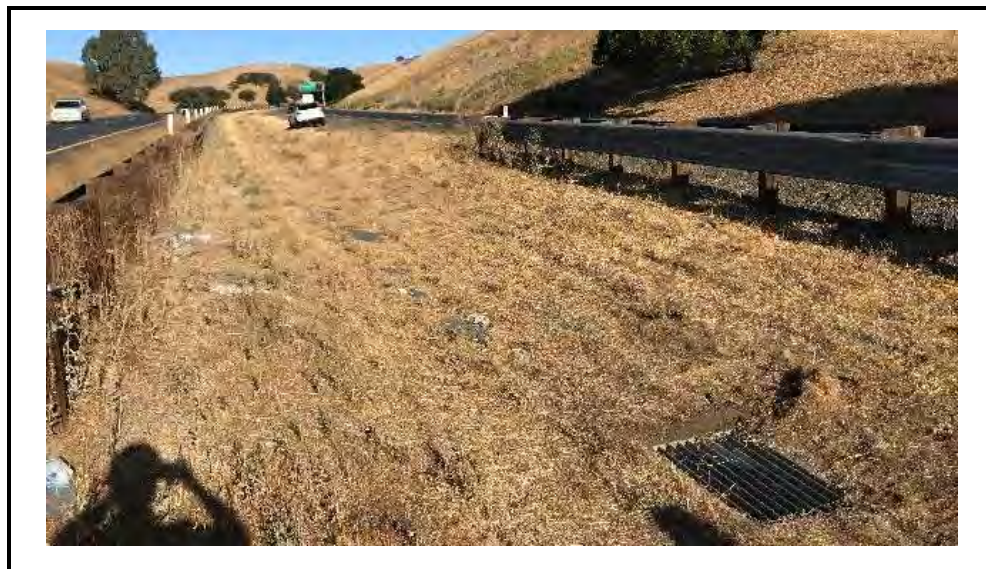

PHOTO B: VEGATED STRIP AND SWALE – DOWNSTREAM (NORTHWEST)

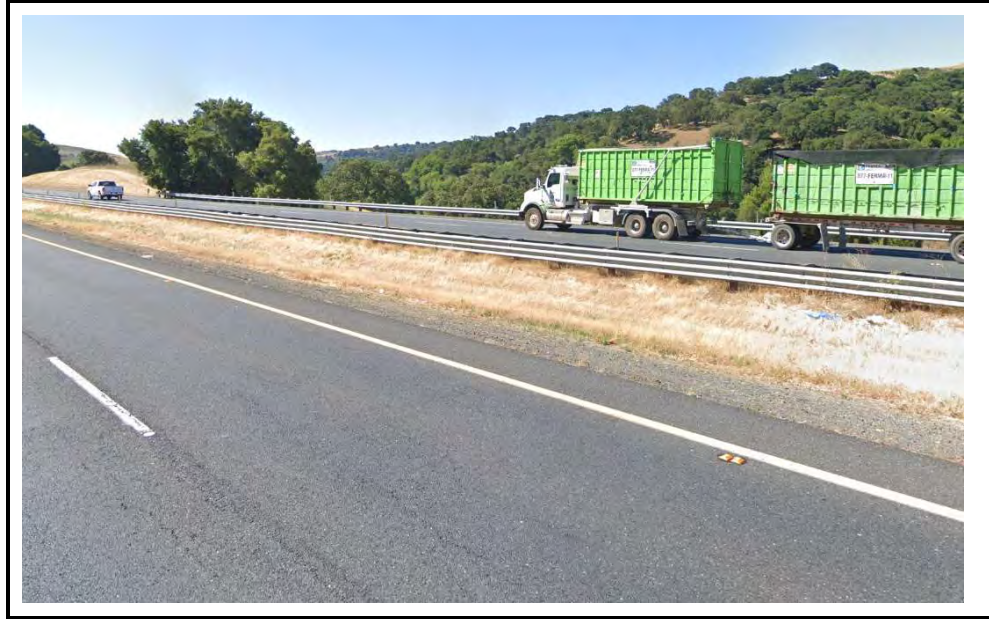

PHOTO C: VEGATED STRIP AND SWALE – DOWNSTREAM (SOUTHEAST)



Site: 2.1 -Cut section with roadside vegetation strip slope between 2:1 and 4:1 (with vegetation strip wider than 10'

Evaluation of Vegetation Effect on Discharge of Trash

Contract 43A0379, Task Order #14

Site Selection

GENERAL SITE INFORMATION: 2.1

District: 4	RWQCB: 2	City: Martinez	County: Contra Costa
Location: 37.995854°, -122.144575°		Route/PM: John Muir Pkwy (Route 4) / CC R7.464	
Type of system: (Type 2) Cut section with roadside vegetation strip slope between 2:1 and 4:1 (with vegetation strip wider than 10'			
Type of vegetation: Medium/Low lying grasses, recently maintained.			Vegetation cover: 80-100%
Tributary Drainage Area: 3.67 Acres (159,718 sq*ft)			

SITE EXHIBIT:



Evaluation of Vegetation Effect on Discharge of Trash

Contract 43A0379, Task Order #14

Site Selection

GENERAL NOTES: Site is within a Moderate Trash Generating Zone (Highway)

Safety Concerns:

- Accessing the proposed project site (2.1) was not observed to be a safety concern.
 - Project site is located along the shoulder and cut slope of route 4 west and is accessed from the right most lane (slow lane).
 - Project location is along a straight away and has good visibility from the road for oncoming traffic.
 - Parking in the shoulder is adequate with a buffer from roadway.
- Ponding is not anticipated to be a concern.
 - Any ponding water will bypassing the last proposed trash capture device and be conveyed to the downstream inlet, downstream.

Site Access Details:

- Project site can be accessed from John Muir Parkway (Hwy 4) west, 2.5 miles from the Alhambra Avenue West onramp.
 - Project site is located along the shoulder and cut slope of route 4 west and is accessed from the right most lane (slow lane).
 - Parking in the shoulder is adequate with a buffer from roadway.
 - Two (2) inlets are located along a 0.3-mile straight roadway section

Security Concerns:

- Is the site subject to vandalism or theft? Yes No
 - Describe: No vandalism or theft concerns. Inlet insert is subsurface.
- Is the site subject to other damage (e.g., errant drivers)? Yes No
 - Describe: No preliminary concern over potential damage. Inlet insert is subsurface.

Maintenance Considerations:

- Project site (2.1) was recently maintained.
 - Little to no trash observed in strip or swale.
 - Vegetation was recently mowed.

Proposed Monitoring Device:

- Two (2) catch basin insert are recommended, one at each proposed drop inlet.
 - An approved Caltrans full trash capture catch basin inert is recommended.
- Total volume of trash will be summed from all trash capture devices.

Sample Drawings: G2 GITS™ for Inlets with Grates

Certified Full Capture Systems – California State Water Board

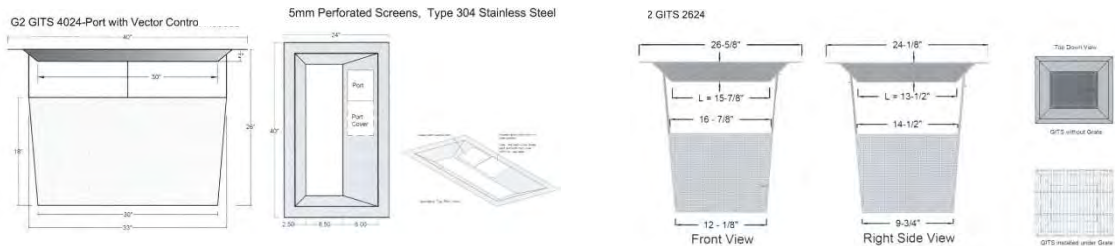

Site: 2.1 -Cut section with roadside vegetation strip slope between 2:1 and 4:1 (with vegetation strip wider than 10')

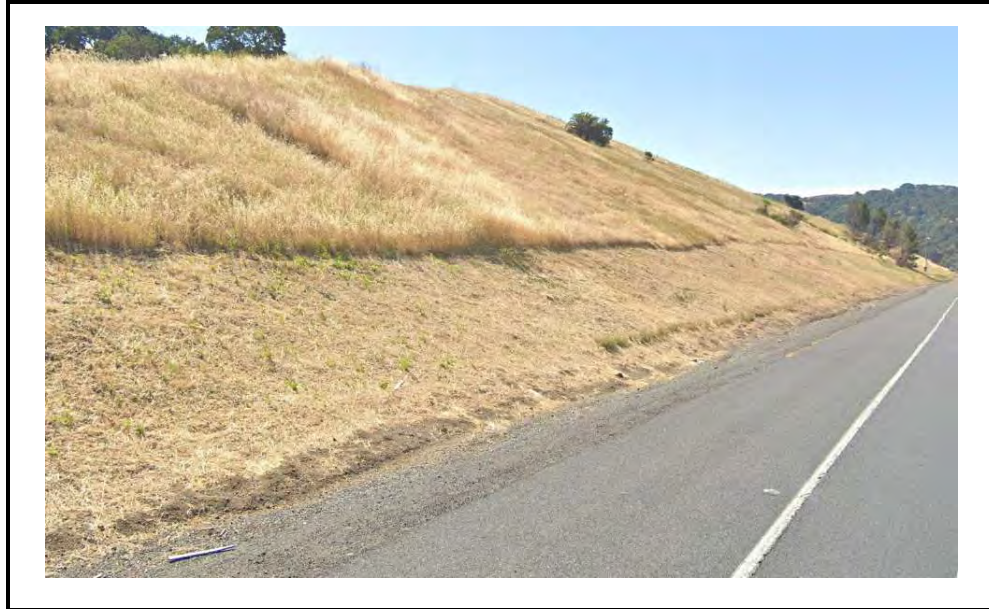

PHOTO A: CUT SLOPE, VEGATED STRIP AND SWALE – (SOUTHEAST)



PHOTO B: CUT SLOPE, STRIP AND TRASH CAPTURE LOCATION – (NORTHEAST)

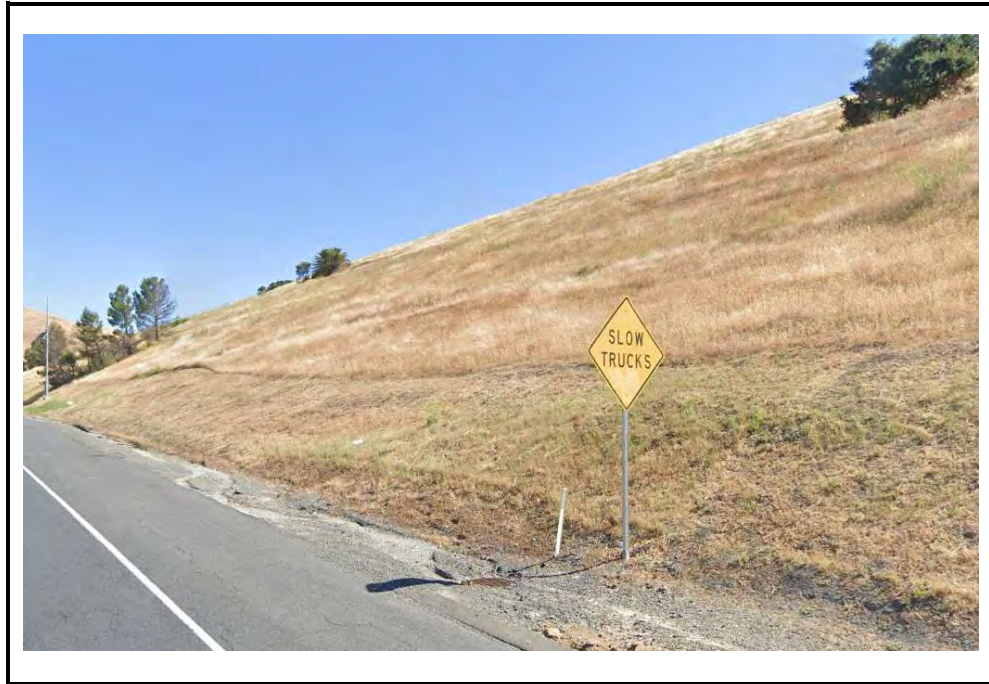

PHOTO C: CUT SLOPE, STRIP AND TRASH CAPTURE LOCATION – (NORTHEAST)



Site: 3.2 - Cut section with vegetation strip slope flatter than 4:1 (with vegetation strip 5'-10')

Evaluation of Vegetation Effect on Discharge of Trash

Contract 43A0379, Task Order #14

Site Selection

GENERAL SITE INFORMATION: 3.2

District: 4	RWQCB: 2	City: San Rafael	County: Marin
Location: 38.005184°, -122.540003°		Route/PM: 101/ MRN 13.561	
Type of system: (Type 3) Cut section with vegetation strip slope flatter than 4:1 (with vegetation strip 5'-10')			
Type of vegetation: Low lying grasses, recently maintained.			Vegetation cover: 80-100%
Tributary Drainage Area: 1.22 Acres (53,201 sq*ft)			

SITE EXHIBIT:

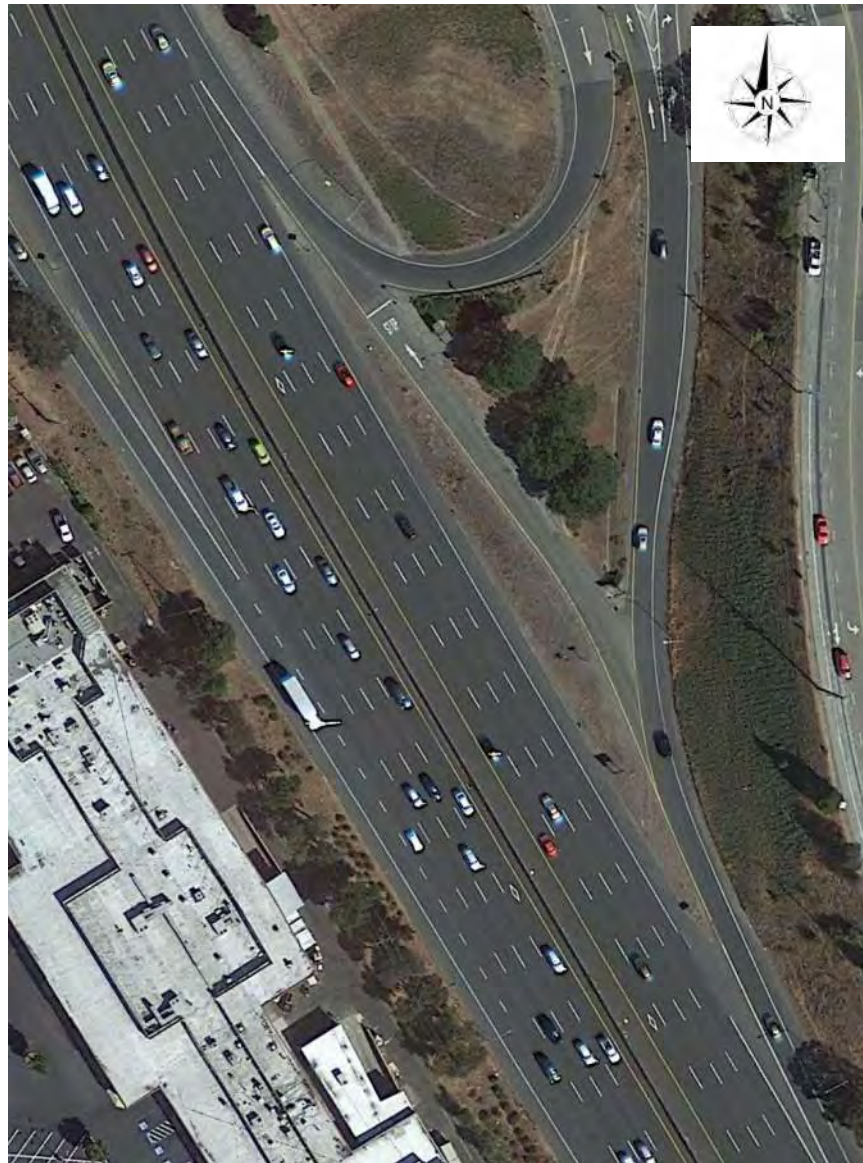



Site: 3.2 - Cut section with vegetation strip slope flatter than 4:1 (with vegetation strip 5'-10')

Evaluation of Vegetation Effect on Discharge of Trash

Contract 43A0379, Task Order #14

Site Selection

GENERAL NOTES: Site is within a Moderate Trash Generating Zone (Highway)

Safety Concerns:

- Accessing the proposed project site (3.2) was not observed to be a safety concern.
 - Project site is located in the right shoulder and is accessed from the right most lane (slow lane).
 - Site can also be safely accessed from Freitas Parkway Terra Linda NB offramp.
 - Project location is along a straight highway section, and has good visibility for oncoming traffic.
 - Parking in the shoulder is adequate with approximately a 10' buffer from roadway and ability to pull over into vegetated shoulder, using vehicle as a physical barrier.
- Ponding is not anticipated to be a concern.

Site Access Details:

- Project site is located on the 101 north, 0.1 miles from the Freitas Parkway Terra Linda offramp, just past Merrydale Road overpass.
 - Project site is located in the right shoulder and is accessed from the right most lane (slow lane).
 - Staff performing construction and monthly monitoring will park within the shoulder, away from road using vehicle as a physical barrier.

Security Concerns:

- Is the site subject to vandalism or theft? Yes No
 - Describe: No vandalism or theft concerns. Inlet insert is subsurface.
- Is the site subject to other damage (e.g., errant drivers)? Yes No
 - Describe: No preliminary concern over damage. Inlet insert is subsurface.

Maintenance Considerations:

- Project site (3.2) was recently maintained.
 - Vegetation was recently mowed.

Proposed Monitoring Device:

- One (1) catch basin inserts is recommended.
 - An approved Caltrans full trash capture catch basin inert is recommended.
- Total volume of trash will be collected from within the proposed capture device.

Sample Drawings: G2 GITS™ for Inlets with Grates

Certified Full Capture Systems – California State Water Board





PHOTO A: CUT SLOPE FLATTER 4:1 WITH 5'-10' VEGETATED STRIP (NORTHEAST)

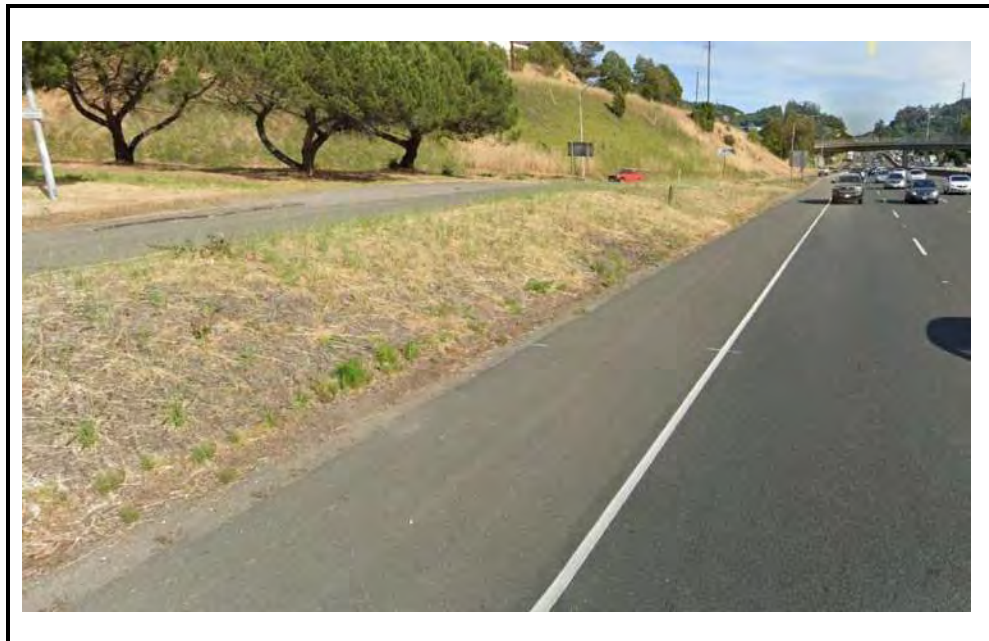

PHOTO B: CUT SLOPE FLATTER 4:1 WITH 5'-10' VEGETATED STRIP (SOUTHEAST)



PHOTO C: DISCHARGE SUMP LOCATION (ARIAL)



PHOTO D: DISCHARGE LOCATION (ARIAL)



Site: 4.1 - Cut section with vegetation strip slope flatter than 4:1 (with vegetation strip wider than 10')

Evaluation of Vegetation Effect on Discharge of Trash

Contract 43A0379, Task Order #14

Site Selection

GENERAL SITE INFORMATION: 4.1

District: 4	RWQCB: 2	City: Oakland	County: Alameda
Location: 37.802497°, -122.299919°		Route/PM: 880/ ALA R33.033	
Type of system: (Type 4) Cut section with vegetation strip slope flatter than 4:1 (with vegetation strip wider than 10')			
Type of vegetation: Low lying grasses, recently maintained.			Vegetation cover: 80-100%
Tributary Drainage Area: 3.16 Acres (137,731 sq*ft)			

SITE EXHIBIT:

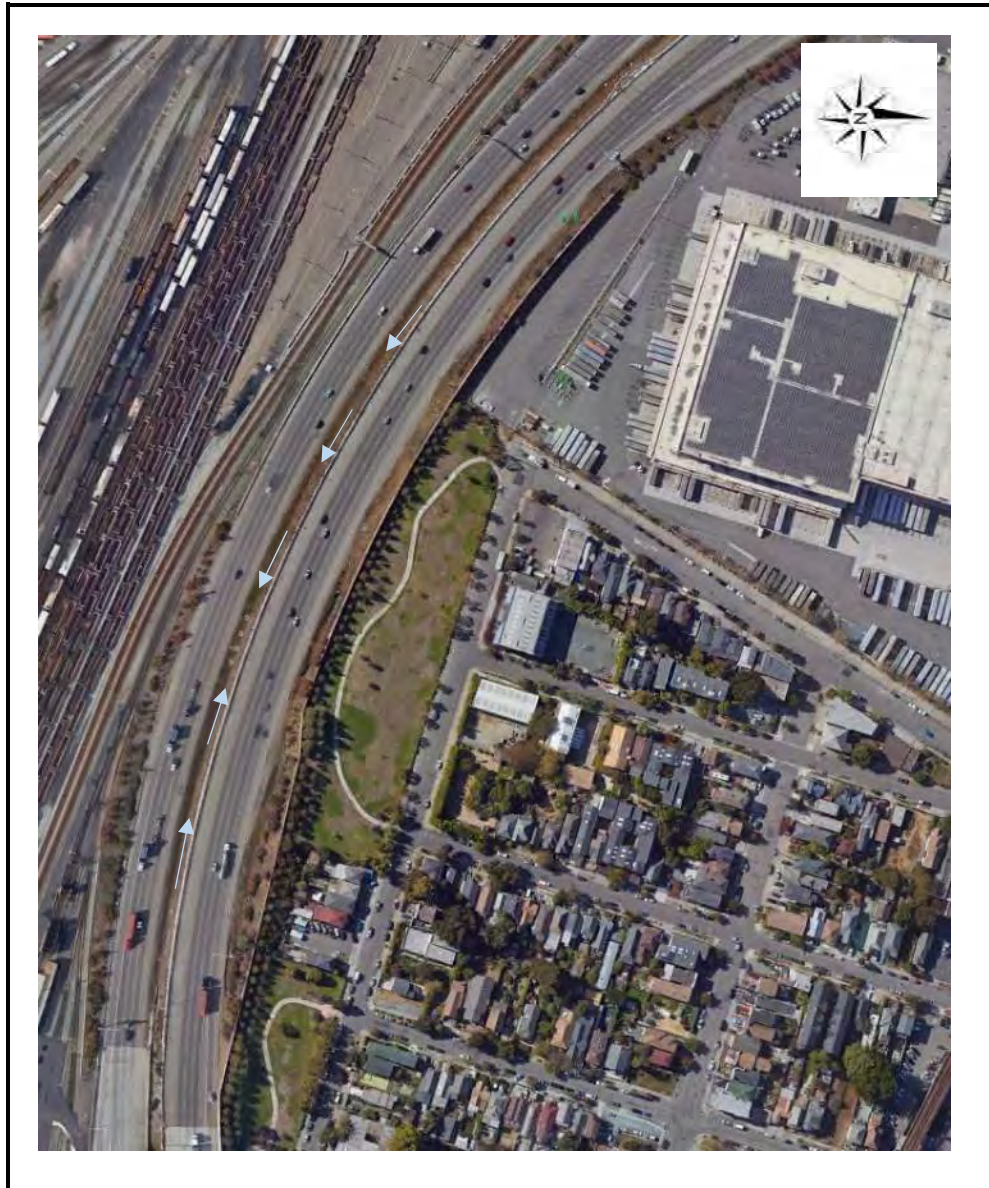



Site: 4.1 - Cut section with vegetation strip slope flatter than 4:1 (with vegetation strip wider than 10')

Evaluation of Vegetation Effect on Discharge of Trash

Contract 43A0379, Task Order #14

Site Selection

GENERAL NOTES: Site is within Moderate Trash Generating Zone

Safety Concerns:

- Accessing the proposed project site (4.1) was not observed to be a safety concern.
 - Project site is located in a central roadway shoulder and is accessed from the left most lane (fast lane).
 - Project location has good visibility from the road for oncoming traffic.
 - Parking in the shoulder is adequate with approximately a 10' buffer from roadway.
- Ponding is not anticipated to be a concern.
 - Central most two (2) drop inlets will capture ponded water, if any, prior to reaching the shoulder.
 -



Site Access Details:

- Project site is located on the 880 south, 0.2 miles from the end of the 7th Street onramp.
 - Project site is located in a central roadway shoulder and is accessed from the left most lane (fast lane).
 - Staff performing construction and monthly monitoring will park within the shoulder, away from road.

Maintenance Considerations:

- Project site (4.1) was recently maintained.
 - Yellow trash bags were observed on the side of the road.
 - Little to no trash observed in strip or swale.
 - Vegetation was recently mowed.

Security Concerns:

- Is the site subject to vandalism or theft? Yes No
 - Describe: No vandalism or theft concerns. Inlet insert is subsurface.
- Is the site subject to other damage (e.g., errant drivers)? Yes No
 - Describe: No preliminary concern over potential damage. Inlet insert is subsurface.

Proposed Monitoring Device:

- Four (4) catch basin inserts are recommended, one (1) at each catch basin.
 - An approved Caltrans full trash capture catch basin inert is recommended.
- Total volume of trash will be summed from all trash capture devices.

Sample Drawings: G2 GITS™ for Inlets with Grates

Certified Full Capture Systems - California State Water Board



Site: 4.1 - Cut section with vegetation strip slope flatter than 4:1 (with vegetation strip wider than 10')



PHOTO A: CAPTURE DEVICE LOCATION (DROP INLET)



PHOTO B: VEGETATED STRIP AND SWALE (NORTH WEST)

Site: 4.1 - Cut section with vegetation strip slope flatter than 4:1 (with vegetation strip wider than 10')



PHOTO C: VEGETATED STRIP AND SWALE - LOOKING UPSTREAM (NORTH EAST)



**PHOTO D: VEGETATED STRIP AND SWALE - LOOKING UPSTREAM
(NORTH WEST)**



Site: 4.1 - Cut section with vegetation strip slope flatter than 4:1 (with vegetation strip wider than 10')

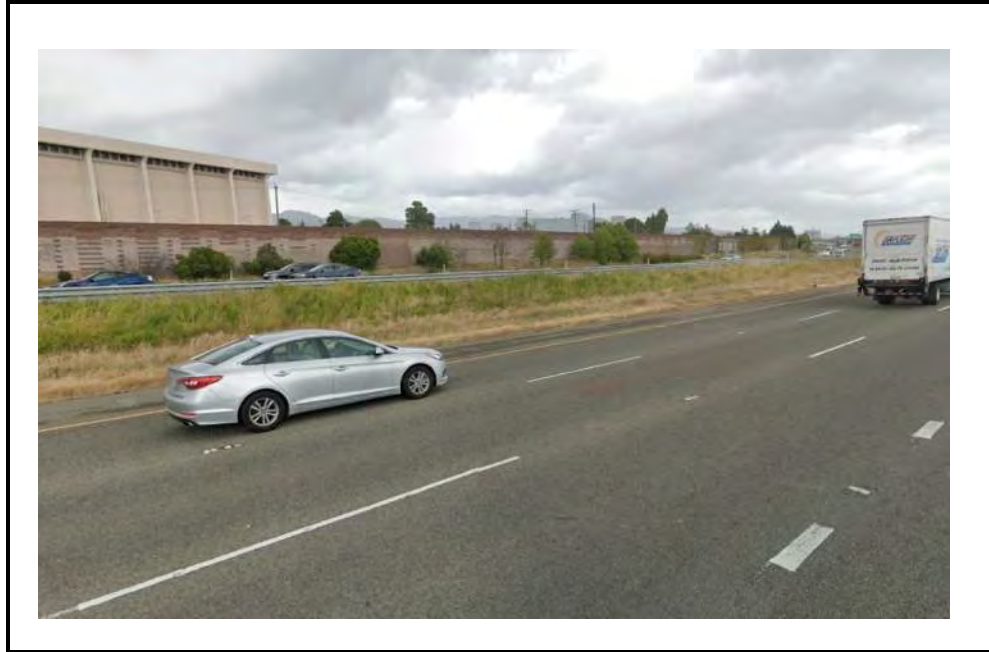

**PHOTO E: VEGETATED STRIP AND SWALE - LOOKING DOWNSTREAM
(NORTH EAST)**



Site: 5.1 - Fill section with roadside vegetation strip slope flatter than 4:1 (sheet flow, 5'-10' to ditch)

Evaluation of Vegetation Effect on Discharge of Trash

Contract 43A0379, Task Order #14

Site Selection

GENERAL SITE INFORMATION: 5.1

District: 3	RWQCB: 5	City: West Sacramento	County: Yolo
Location: 38.573484°, -121.579345°		Route/PM: 80/ YOL 9.082	
Type of system: (Type 5) Fill section with roadside vegetation strip slope flatter than 4:1 (sheet flow, 5'-10' to ditch)			
Type of vegetation: Low lying grasses, recently maintained.			Vegetation cover: 80-100%
Tributary Drainage Area: 3.00 Acres (130,706 sq*ft)			

SITE EXHIBIT:

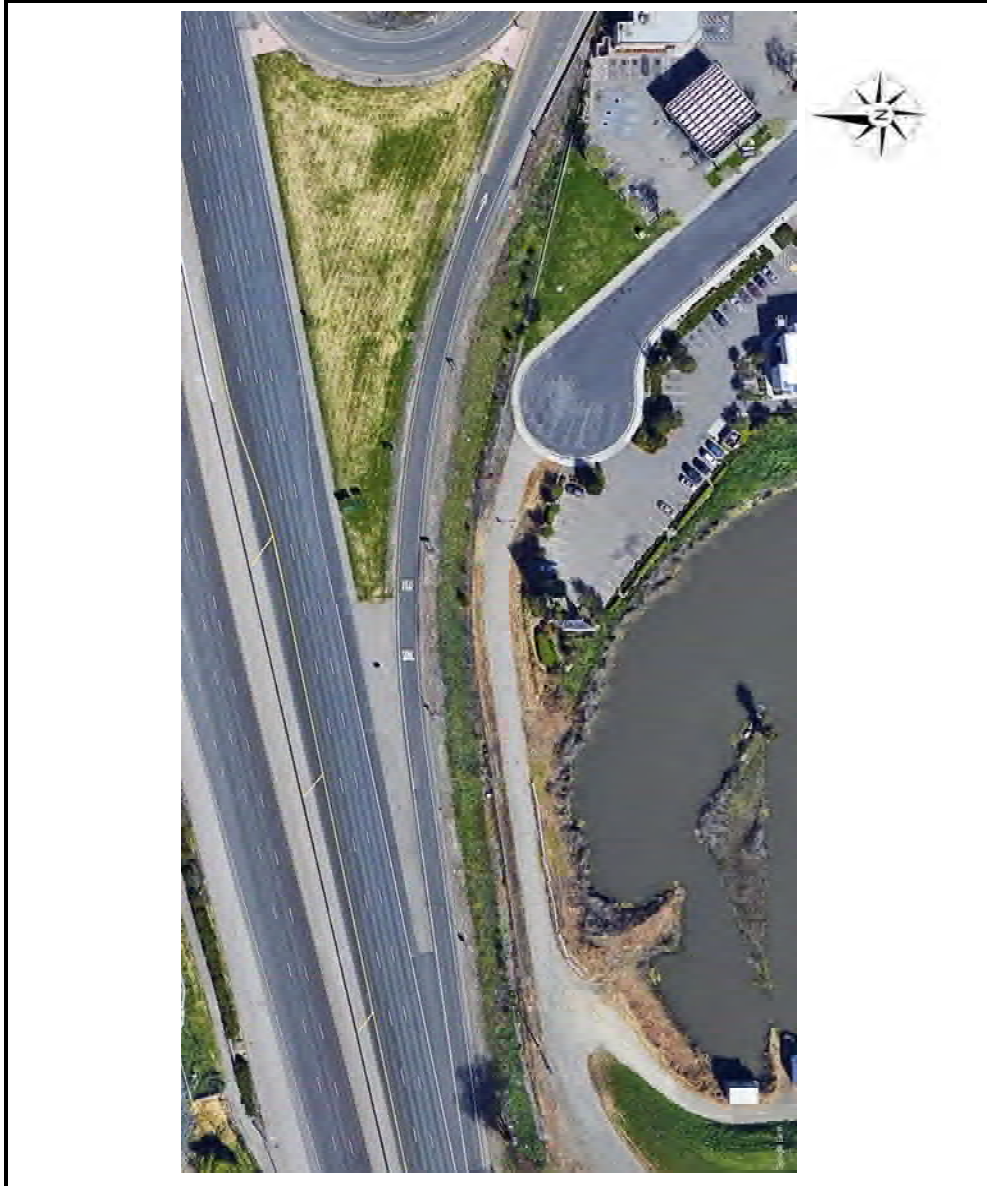



Site: 5.1 - Fill section with roadside vegetation strip slope flatter than 4:1 (sheet flow, 5'-10' to ditch)

Evaluation of Vegetation Effect on Discharge of Trash

Contract 43A0379, Task Order #14

Site Selection

GENERAL NOTES: Site is within a Moderate Trash Generating Zone and Ramp

Safety Concerns:

- Accessing the proposed project site (5.1) was not observed to be a safety concern.
- Project site is located in an infield bounded by the West Capital Ave Enterprise Road On/Off Ramps and the 80 east.
 - Project location has good visibility from the road for oncoming traffic.
 - Parking in the shoulder is adequate with approximately a 10' buffer from roadway.
 - Vehicles can pull into infield for added safety

Site Access Details:

- Project site is located on the 80 east, within an infield bounded by the West Capital Ave Enterprise Road On/Off Ramps and the 80 east.
 - Project site can be accessed from the right most lane (slow lane), just past the final exit sign for West Capital Ave Enterprise Road.
 - Staff performing construction and monthly monitoring will park within the infield, away from road.

Maintenance Considerations:

- Project site (5.1) was recently maintained.
 - Vegetation was recently mowed.

Security Concerns:

- Is the site subject to vandalism or theft? Yes No
 - Describe: No vandalism or theft concerns. Inlet insert is subsurface.
- Is the site subject to other damage (e.g., errant drivers)? Yes No
 - Describe: No preliminary concern over potential damage. Inlet insert is subsurface.

Proposed Monitoring Device:

- One (1) catch basin insert is recommended, at the discharge location (end of swale).
 - An approved Caltrans full trash capture catch basin insert is recommended.

Sample Drawings: G2 GITS™ for Inlets with Grates

Certified Full Capture Systems - California State Water Board



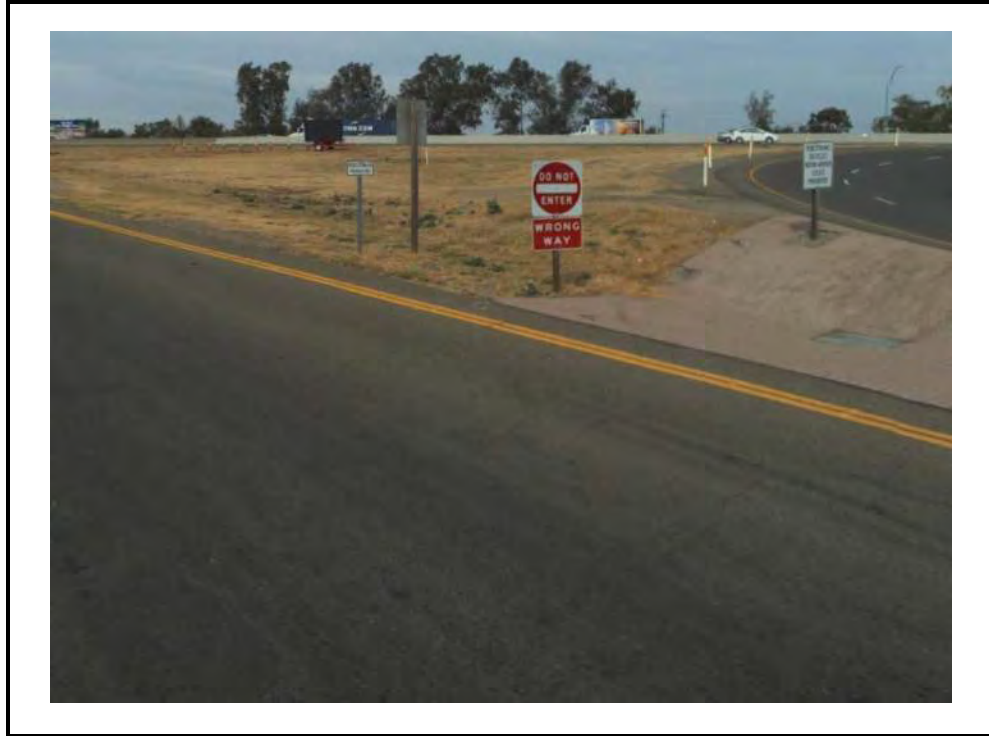

PHOTO A: CAPTURE DEVICE LOCATION (DROP INLET)



**PHOTO B: CAPTURE DEVICE LOCATION
TRASH AND DEBRIS OBSERVED AT GRATE**

Site: 5.1 - Fill section with roadside vegetation strip slope flatter than 4:1 (sheet flow, 5'-10' to ditch)



PHOTO C: VEGETATED STRIP AND SWALE - (NORTHEAST)



PHOTO D: VEGETATED STRIP, SWALE AND SHOULDER (NORTHWEST)



Site: 5.1 - Fill section with roadside vegetation strip slope flatter than 4:1 (sheet flow, 5'-10' to ditch)

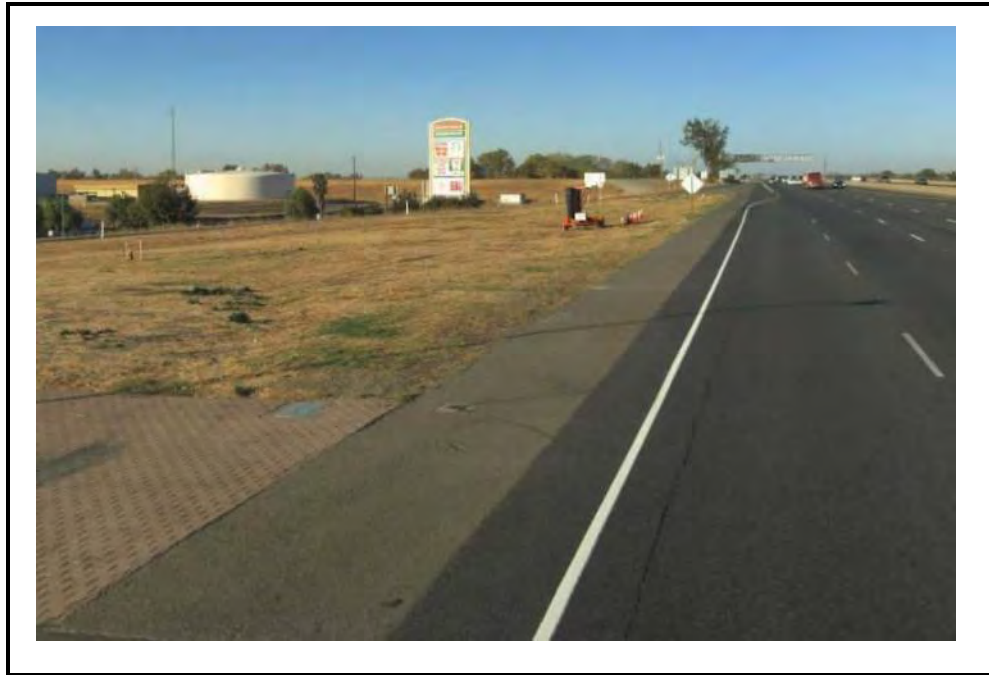

PHOTO E: VEGETATED STRIP AND SWALE (SOUTHWEST)



Site: 6.1 - Fill section with roadside vegetation strip slope flatter than 4:1 (sheet flow, 10'-20' to ditch)

Evaluation of Vegetation Effect on Discharge of Trash

Contract 43A0379, Task Order #14

Site Selection

GENERAL SITE INFORMATION: 6.1

District: 4

RWQCB: 2

City: San Jose

County: Santa Clara

Location: 37.31638253°, -121.95201488°

Route/PM: 280/SCL 4.667

Type of system: (Type 6) Fill section with roadside vegetation strip slope flatter than 4:1 (sheet flow, 10'-20' to ditch)

Type of vegetation: Grasses, trees, and shrubs.

Vegetation cover: 80-100%

Tributary Drainage Area: 1.63 Acres (71,002.8 sq*ft)

SITE EXHIBIT:





Site: 6.1 - Fill section with roadside vegetation strip slope flatter than 4:1 (sheet flow, 10'-20' to ditch)

Evaluation of Vegetation Effect on Discharge of Trash

Contract 43A0379, Task Order #14

Site Selection

GENERAL NOTES: Site is within a Moderate Trash Generating Zone (Ramp)

Safety Concerns:

- Accessing the proposed project site (6.1) was not observed to be a safety concern.
 - Project site is located in the right shoulder and is accessed from the right most lane (off-ramp).
 - Parking in the shoulder is adequate with approximately a 10' buffer from roadway.
- Ponding is not expected to be a concern.
- High visibility markers will be placed on all above ground, retrofitted trash capture devices, if any.
 - Retrofitted trash capture devices, if any, will maintain a low profile and be constructed from collapsible materials, if emergency access to the shoulder is required.

Site Access Details:

- Project site is located on the 280 south, at the Winchester Boulevard off-ramp.
 - Project site is located in the right shoulder and is accessed from the right most lane (off-ramp).
 - Staff performing construction and monthly monitoring will park within the shoulder, away from road.

Maintenance Considerations:

Security Concerns:

- Is the site subject to vandalism or theft? Yes No
 - Describe: _____
- Is the site subject to other damage (e.g., errant drivers)? Yes No
 - Describe: _____

Proposed Monitoring Device:

- One (1) site specific, retrofitted trash capture device (for swales) is recommended, five (5) feet upstream of the northeastern most drop inlet.
 - Proposed device will capture trash and vegetative debris, while preventing clogging of downstream catch basin inserts.
- One (1) catch basin insert is recommended at the drop inlet.
 - An approved Caltrans full trash capture catch basin insert is recommended.
- Total volume of trash from within the capture device will be used.

Sample Drawings: G2 GITS™ for Inlets with Grates

Certified Full Capture Systems – California State Water Board





PHOTO A: VEGETATED STRIP (EAST)



PHOTO B: VEGETATED STRIP AND SWALE (WEST)



PHOTO C: VEGETATED STRIP AND SWALE (WEST)



PHOTO D: VEGETATED STRIP AND SWALE AT DISCHARGE POINT (EAST)



Site: 7.1 - Fill section with roadside vegetation strip slope flatter than 4:1 (diked/curbed, 5-10' to ditch)

Evaluation of Vegetation Effect on Discharge of Trash

Contract 43A0379, Task Order #14

Site Selection

GENERAL SITE INFORMATION: 7.1

District: 4	RWQCB: 2	City: Richmond	County: Contra Costa
Location: 37.922191, -122.34692°		Route/PM: 580/ CC R2.853	
Type of system: (Type 7) Fill section with roadside vegetation strip slope flatter than 4:1 (diked/curbed, 5-10' to ditch)			
Type of vegetation: Low lying grasses, recently maintained.			Vegetation cover: 80-100%
Tributary Drainage Area: 1.09 Acres (47,567 sq*ft)		STGA Category: MODERATE	

SITE EXHIBIT:





Site: 7.1 - Fill section with roadside vegetation strip slope flatter than 4:1 (diked/curbed, 5-10' to ditch)

Evaluation of Vegetation Effect on Discharge of Trash

Contract 43A0379, Task Order #14

Site Selection

GENERAL NOTES: Site is within a Moderate Trash Generating Zone

Safety Concerns:

- Accessing the proposed project site (7.1) was not observed to be a safety concern.
- Project site is located within the infield bounded by the 580 West and the on ramp from Mariana Bay Parkway.
 - Project location has good visibility from the road for oncoming traffic.
 - Parking in the adjacent infield shoulder is adequate with approximately a 10' buffer from roadway.
 - Vehicles can pull off to shoulder onto lower ramp.

Site Access Details:

- Project site is located within the infield bounded by the 580 West and the on ramp from Mariana Bay Parkway.
 - Project site can be accessed from the Mariana Bay Parkway, 580 West on ramp.
 - Staff performing construction and monthly monitoring will park within the infield, away from road.

Maintenance Considerations:

- Project site (7.1) was recently maintained.
 - Vegetation was recently mowed.

Security Concerns:

- Is the site subject to vandalism or theft? Yes No
 - Describe: No vandalism or theft concerns. Inlet insert is subsurface.
- Is the site subject to other damage (e.g., errant drivers)? Yes No
 - Describe: No preliminary concern over potential damage. Inlet insert is subsurface.

Proposed Monitoring Device:

- One (1) catch basin insert is recommended, at the discharge location (end of concrete dike).
 - An approved Caltrans full trash capture catch basin insert is recommended.

Sample Drawings: G2 GITS™ for Inlets with Grates

Certified Full Capture Systems – California State Water Board



Site: 7.1 - Fill section with roadside vegetation strip slope flatter than 4:1 (diked/curbed, 5-10' to ditch)



PHOTO A: CURB/DIKE – UPSTREAM (NORTHEAST)



PHOTO B: VEGETATED STRIP AND SWALE (SOUTH)

Site: 7.1 - Fill section with roadside vegetation strip slope flatter than 4:1 (diked/curbed, 5-10' to ditch)



**PHOTO C: VEGETATED STRIP, SWALE AND DISCHARGE POINT
LOOKING UPSTREAM (NORTHEAST)**



PHOTO D: CAPTURE DEVICE LOCATION (SOUTHWEST)



Site: 8.1 - Fill section with roadside vegetation strip slope flatter than 4:1 (diked/curbed, 10'-20'' to ditch)

Evaluation of Vegetation Effect on Discharge of Trash

Contract 43A0379, Task Order #14

Site Selection

GENERAL SITE INFORMATION: 8.1

District: 1	RWQCB: 5	City: Petaluma	County: Sonoma
Location: 38.234342°, -122.617701°		Route/PM: 101 NB / SON 35.045	
Type of system: (Type 8) Fill section with roadside vegetation strip slope flatter than 4:1 (diked/curbed, 10'-20'' to ditch)			
Type of vegetation: Low lying grasses, recently maintained.			Vegetation cover: 80-100%
Tributary Drainage Area: 2.09 Acres (90,825 sq*ft)			

SITE EXHIBIT:



Evaluation of Vegetation Effect on Discharge of Trash

Contract 43A0379, Task Order #14

Site Selection

GENERAL NOTES: Site is within a Moderate Trash Generating Zone and Ramp

Safety Concerns:

- Accessing the proposed project site (8.1) was not observed to be a safety concern.
- Project site is located in infield fill slope east of the 101 North, 116 East Sonoma Napa Exit (472B) .
 - Project location has good visibility from the road for oncoming traffic.
 - Parking in the adjacent infield shoulder is adequate with approximately a 10' buffer from roadway.
 - Vehicles can pull off in the infield for added safety

Site Access Details:

- Project site is located in infield fill slope east of the 101 North, 116 East Sonoma Napa Exit (472B)
 - Project site can be accessed from the 116 East Sonoma Napa Exit ramp (472B).
 - Staff performing construction and monthly monitoring will park within the infield, away from road.

Maintenance Considerations:

- Project site (8.1) was recently maintained.
 - Vegetation was recently mowed.

Security Concerns:

- Is the site subject to vandalism or theft? Yes No
 - Describe: No vandalism or theft concerns. Inlet insert is subsurface.
- Is the site subject to other damage (e.g., errant drivers)? Yes No
 - Describe: No preliminary concern over potential damage. Inlet insert is subsurface.

Proposed Monitoring Device:

- Two (2) catch basin inserts are recommended, at each of the the discharge location (drop inlets).
 - An approved Caltrans full trash capture catch basin inert is recommended.

Sample Drawings: G2 GITS™ for Inlets with Grates

Certified Full Capture Systems – California State Water Board



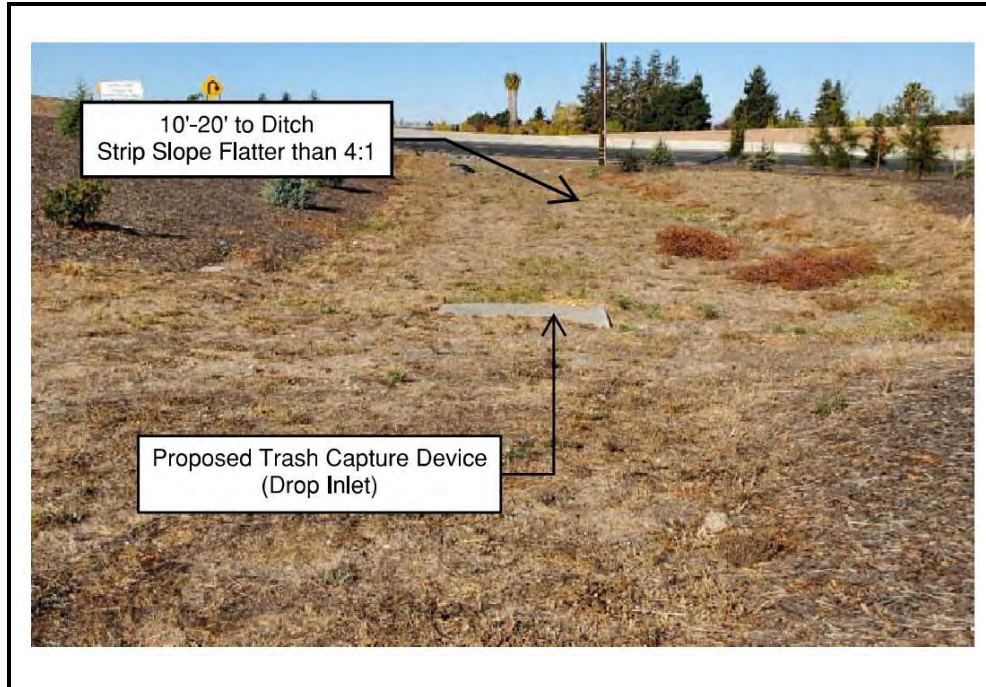

PHOTO A: OVSIDE DRAIN TO CAPTURE DEVICE LOCATION (DROP INLET)



PHOTO B: VEGETATED STRIP AND SWALE LOOKING (NORTH)



Site: 8.1 - Fill section with roadside vegetation strip slope flatter than 4:1 (diked/curbed, 10'-20" to ditch)



PHOTO C: VEGETATED STRIP - LOOKING UPSTREAM (NORTHWEST)



Site: 9.1 - Fill section with roadside vegetation strip slope between 2:1 and 4:1 (diked/curbed, 5-10' to ditch)

Evaluation of Vegetation Effect on Discharge of Trash

Contract 43A0379, Task Order #14

Site Selection

GENERAL SITE INFORMATION: 9.1

District: 3	RWQCB: 5	City: West Sacramento	County: Yolo
Location: 38.574994°, -121.575086°		Route/PM: 80/ YOL 9.331	
Type of system: (Type 9) Fill section with roadside vegetation strip slope between 2:1 and 4:1 (diked/curbed, 5-10' to ditch)			
Type of vegetation: Low lying grasses, recently maintained.			Vegetation cover: 80-100%
Tributary Drainage Area: 1.60 Acres (69,534 sq*ft)			

SITE EXHIBIT:





Site: 9.1 - Fill section with roadside vegetation strip slope between 2:1 and 4:1 (diked/curbed, 5-10' to ditch)

Evaluation of Vegetation Effect on Discharge of Trash

Contract 43A0379, Task Order #14

Site Selection

GENERAL NOTES: Site is within a Moderate Trash Generating Ramp

Safety Concerns:

- Accessing the proposed project site (9.1) was not observed to be a safety concern.
- Project site is located in the shoulder west of the the 80 West, Enterprise Blvd West Capitol Avenue on ramp.
 - Project location has good visibility from the road for oncoming traffic.
 - Parking in the adjacent infield shoulder is adequate with approximately a 10' buffer from roadway.
 - Vehicles can pull off in the infield for added safety

Site Access Details:

- Project site is located in the shoulder west of the 80 West, Enterprise Blvd West Capitol Avenue on ramp.
 - Staff performing construction and monthly monitoring will park within the infield, away from road.

Maintenance Considerations:

- Project site (9.1) was recently maintained.
 - Vegetation was recently mowed.

Security Concerns:

- Is the site subject to vandalism or theft? Yes No
 - Describe: No vandalism or theft concerns. Inlet insert is subsurface.
- Is the site subject to other damage (e.g., errant drivers)? Yes No
 - Describe: No preliminary concern over potential damage. Inlet insert is subsurface.

Proposed Monitoring Device:

- One (1) catch basin insert is recommended, at the discharge location (end of swale).
 - An approved Caltrans full trash capture catch basin inert is recommended.

Sample Drawings: G2 GITS™ for Inlets with Grates

Certified Full Capture Systems – California State Water Board





PHOTO A: DROP INLET - CAPTURE DEVICE LOCATION (SOUTH)



PHOTO B: VEGETATED STRIP AND SWALE (NORTHWEST)



PHOTO C: ROAD, VEGETATED STRIP AND CURB - LOOKING DOWNSTREAM (NORTH)



PHOTO D: ROAD AND CURB - LOOKING DOWNSTREAM (NORTHEAST)



Site: 8.2 - Fill section with roadside vegetation strip slope flatter than 4:1 (diked/curbed, 10'-20'' to ditch)

Evaluation of Vegetation Effect on Discharge of Trash

Contract 43A0379, Task Order #14

Site Selection

GENERAL SITE INFORMATION: 8.2

District: 4	RWQCB: 2	City: Santa Clara	County: Santa Clara
Location: 37.41478300°, -121.97897486°		Route/PM: 237/SCL R5.763	
Type of system: (Type 8) Fill section with roadside vegetation strip slope flatter than 4:1 (diked/curbed, 10'-20'' to ditch)			
Type of vegetation: Grasses, wildflowers, trees, and shrubs.			Vegetation cover: 80-100%
Tributary Drainage Area: 1.74 Acres (75,794.4 sq*ft)			

SITE EXHIBIT:

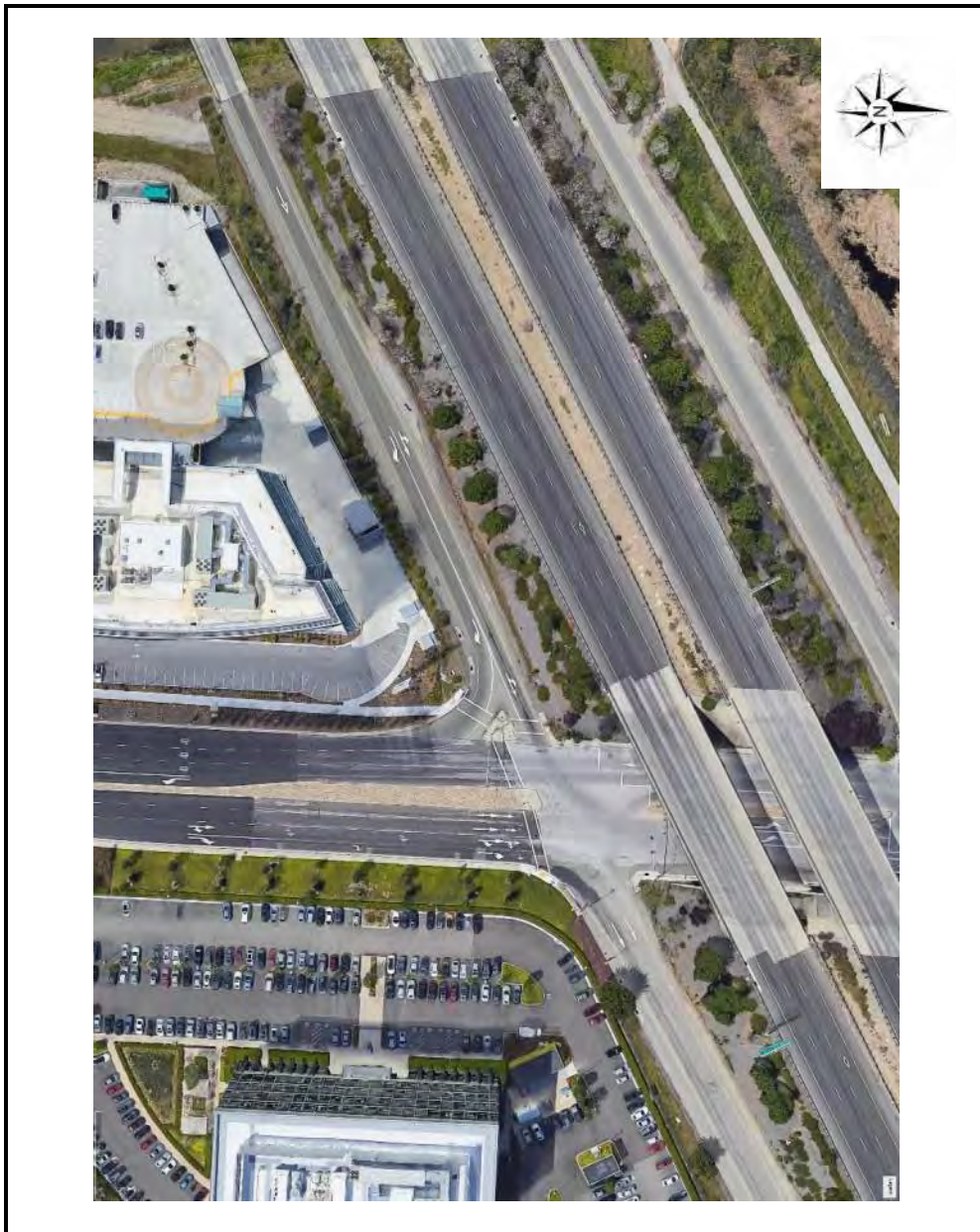

Evaluation of Vegetation Effect on Discharge of Trash

Contract 43A0379, Task Order #14

Site Selection

GENERAL NOTES: Site is within a Moderate Trash Generating Zone (Ramp and Highway)

Safety Concerns:

- Accessing the proposed project site (8.2) was not observed to be a safety concern.
 - Project site is located in the right shoulder of the highway and is accessed from the right most lane (off-ramp).
 - Parking in the left shoulder of the off-ramp is adequate with approximately a 10' buffer from roadway.
- Ponding is not expected to be a concern.
- High visibility markers will be placed on all above ground, retrofitted trash capture devices, if any.
 - Retrofitted trash capture devices, if any, will maintain a low profile and be constructed from collapsible materials, if emergency access to the shoulder is required.

Site Access Details:

- Project site is located on the 237 east, at the Great America Parkway / Lafayette Street off-ramp.
 - Project site is located in the right shoulder of the highway and is accessed from the right most lane (off-ramp).
 - Staff performing construction and monthly monitoring will park within the left shoulder of the off-ramp, away from road.

Maintenance Considerations: Area was recently maintained.

Security Concerns:

- Is the site subject to vandalism or theft? Yes No
 - Describe: _____
- Is the site subject to other damage (e.g., errant drivers)? Yes No
 - Describe: _____

Proposed Monitoring Device:

- One (1) site specific, retrofitted trash capture device (for swales) is recommended, five (5) feet upstream of the easternmost drop inlet.
 - Proposed device will capture trash and vegetative debris, while preventing clogging of downstream catch basin inserts.
- One (1) catch basin insert is recommended at the easternmost drop inlet.
 - An approved Caltrans full trash capture catch basin insert is recommended.
- Total volume of trash from within the capture device will be used.

Sample Drawings: G2 GITS™ for Inlets with Grates

Certified Full Capture Systems – California State Water Board



Site: 8.2 - Fill section with roadside vegetation strip slope flatter than 4:1 (diked/curbed, 10'-20" to ditch)

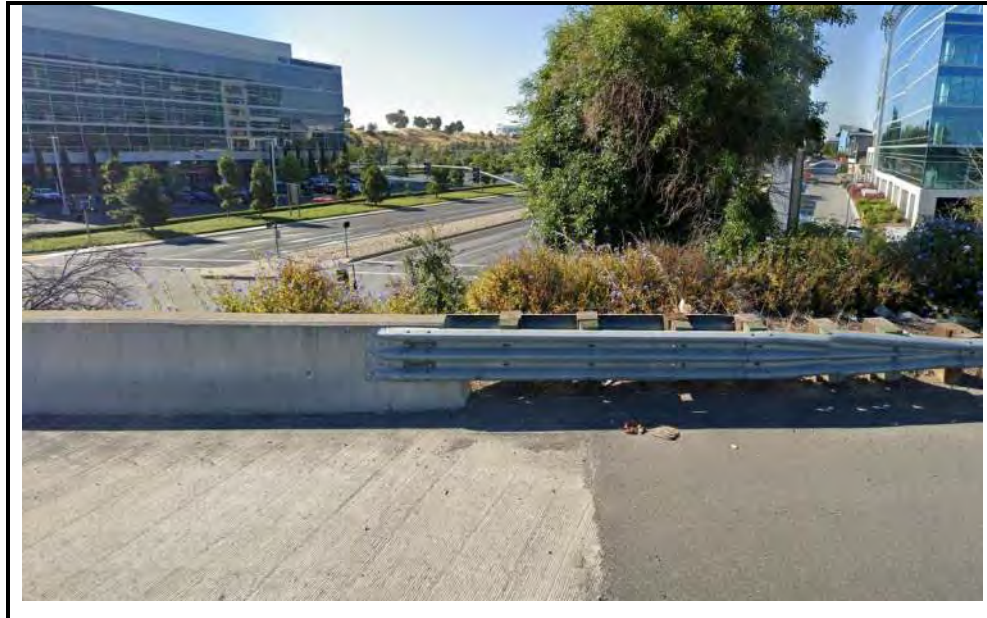

PHOTO A: CURB (SOUTH)



PHOTO B: UPSTREAM INLETS AND VEGETATED STRIP (SOUTH)



PHOTO C: VEGETATED STRIP AND SWALE (SOUTH)



PHOTO D: VEGETATED STRIP AND SWALE AT DISCHARGE POINT (WEST)



Site: 11 - Fill section with roadside vegetation strip slope between 2:1 and 4:1 (diked/curbed, 5-10' to ditch)

Evaluation of Vegetation Effect on Discharge of Trash

Contract 43A0379, Task Order #14

Site Selection

GENERAL SITE INFORMATION: 11

District: 12	RWQCB: 8	City: Buena Park	County: Orange
Location: 33.8726993811, -118.007992576		Route/PM: 5/ ORA 44.164	
Type of system: (Type 9) Fill section with roadside vegetation strip slope between 2:1 and 4:1 (diked/curbed, 5-10' to ditch)			
Type of vegetation: Low lying grasses and perennials, recently maintained.			Vegetation cover: 80-100%
Tributary Drainage Area: 0.86 Acres (37,403 SF)		STGA Category: HIGH	

SITE EXHIBIT:



Evaluation of Vegetation Effect on Discharge of Trash

Contract 43A0379, Task Order #14

Site Selection

GENERAL NOTES: Site is within a High Trash Generating Zone (Highway)

Safety Concerns:

- Accessing the proposed project site (1) was not observed to be a safety concern.
 - Project site is located in the northbound Artesia Blvd on-ramp/off-ramp infield area off the 5 freeway and is accessed from the right most lane (slow lane) of the 5 freeway.
 - Site can also be safely accessed from the Artesia northbound off-ramp from the left-most lane.
 - Project location is along in the on-ramp/off-ramp infield area and has good visibility for oncoming traffic.
 - Parking along the shoulder is adequate with approximately a 10' buffer from roadway and ability to pull over into vegetated shoulder, using vehicle as a physical barrier.
- Ponding is not anticipated to be a concern.

Site Access Details:

- Project site is located on the 5 North, in the Artesia Blvd. on-ramp/off-ramp infield area.
 - Project site is located in the right shoulder of the 5 freeway and is accessed from the right most lane (slow lane).
 - Staff performing construction and monthly monitoring will park within the shoulder, away from road using vehicle as a physical barrier.

Security Concerns:

- Is the site subject to vandalism or theft? Yes No
 - Describe: No vandalism or theft concerns. Inlet insert is subsurface.
- Is the site subject to other damage (e.g., errant drivers)? Yes No
 - Describe: No preliminary concern over damage. Inlet insert is subsurface.

Maintenance Considerations:

- Project site (1) was recently maintained.
 - Vegetation was recently trimmed down.

Proposed Monitoring Device:

- One (1) catch basin insert is recommended.
 - An approved Caltrans full trash capture catch basin insert is recommended.
- Total volume of trash will be summed from trash collected within the proposed capture device.

Sample Drawings: G2 GITS™ for Inlets with Grates

Certified Full Capture Systems – California State Water Board





PHOTO A: Fill section with roadside vegetation strip slope between 2:1 and 4:1 (diked/curbed, 5-10' to ditch) (NORTHEAST)

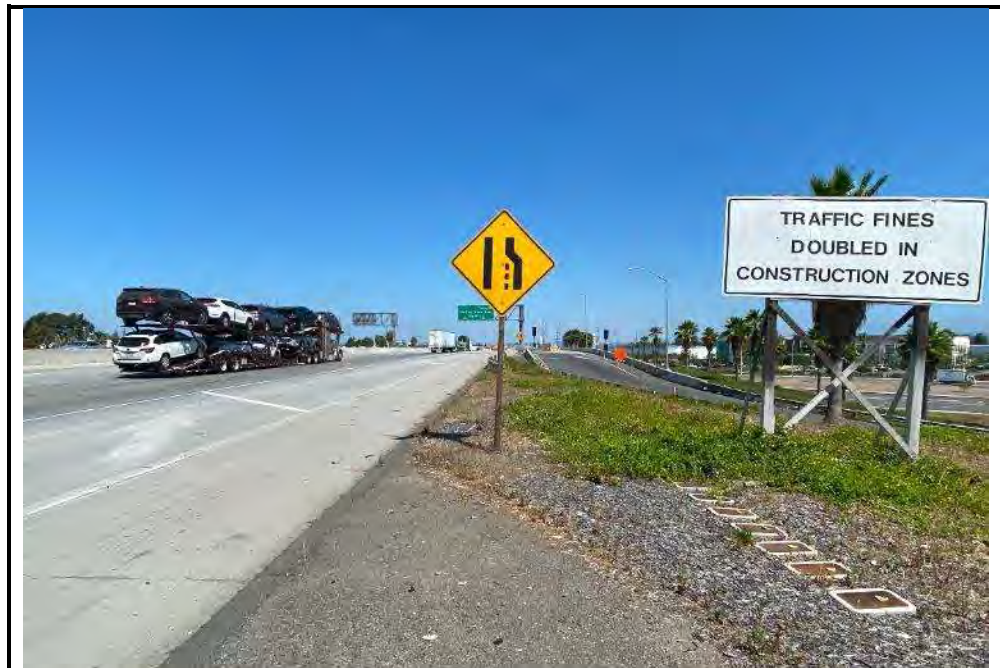

PHOTO B: Fill section with roadside vegetation strip slope between 2:1 and 4:1 (diked/curbed, 5-10' to ditch) (NORTHWEST)



PHOTO C: Fill section with roadside vegetation strip slope between 2:1 and 4:1 (diked/curbed, 5-10' to ditch) (SOUTHEAST)



Site: 12 - Fill section with roadside vegetation strip slope flatter than 4:1 (diked/curbed, 10'-20" to ditch)

Evaluation of Vegetation Effect on Discharge of Trash

Contract 43A0379, Task Order #14

Site Selection

GENERAL SITE INFORMATION: 12

District: 12	RWQCB: 8	City: Anaheim	County: Orange
Location: 33.8454527778, -117.957688889		Route/PM: 5/ ORA 40.648	
Type of system: (Type 8) Fill section with roadside vegetation strip slope flatter than 4:1 (diked/curbed, 10'-20" to ditch)			
Type of vegetation: Low lying grasses, recently maintained.			Vegetation cover: 80-100%
Tributary Drainage Area: 1.43 Acres (62,291 SF)		STGA Category: HIGH	

SITE EXHIBIT:

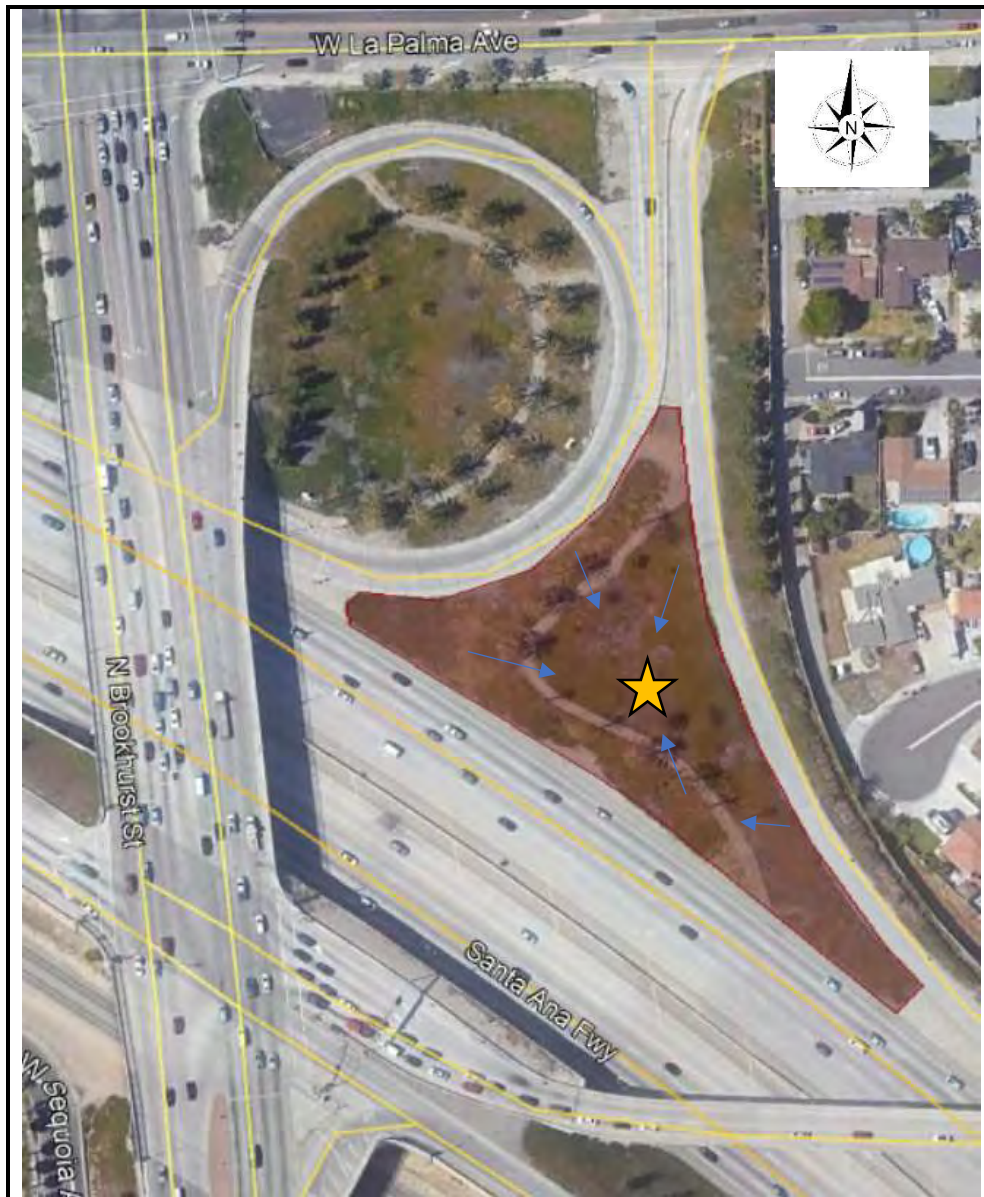

Evaluation of Vegetation Effect on Discharge of Trash

Contract 43A0379, Task Order #14

Site Selection

GENERAL NOTES: Site is within a High Trash Generating Zone (Highway)

Safety Concerns:

- Accessing the proposed project site (2) was not observed to be a safety concern.
 - Project site is located in the northbound La Palma Ave on-ramp/off-ramp infield area off the 5 freeway and is accessed from the right most lane (slow lane) of the 5 freeway.
 - Site can also be safely accessed from the La Palma Ave northbound off-ramp from the left-most lane at a paved vehicle pull-out.
 - Project location is along in the on-ramp/off-ramp infield area and has good visibility for oncoming traffic.
 - Parking in the shoulder is adequate with approximately a 10' buffer from roadway and ability to pull over into vegetated shoulder, using vehicle as a physical barrier.
- Ponding is not anticipated to be a concern.

Site Access Details:

- Project site is located on the 5 north, in the La Palma Ave. northbound on-ramp/off-ramp infield area.
 - Project site is located in the infield area off the 5 freeway and is accessed from the right most lane (slow lane) of the freeway.
 - Staff performing construction and monthly monitoring will park within the shoulder, away from road using vehicle as a physical barrier.

Security Concerns:

- Is the site subject to vandalism or theft? Yes No
 - Describe: No vandalism or theft concerns. Inlet insert is subsurface.
- Is the site subject to other damage (e.g., errant drivers)? Yes No
 - Describe: No preliminary concern over damage. Inlet insert is subsurface.

Maintenance Considerations:

- Project site (2) was recently maintained.
 - Vegetation was recently trimmed down.

Proposed Monitoring Device:

- One (1) catch basin insert is recommended.
 - An approved Caltrans full trash capture catch basin insert is recommended.
- Total volume of trash will be summed from trash collected within the proposed capture device.

Sample Drawings: G2 GITS™ for Inlets with Grates

Certified Full Capture Systems – California State Water Board

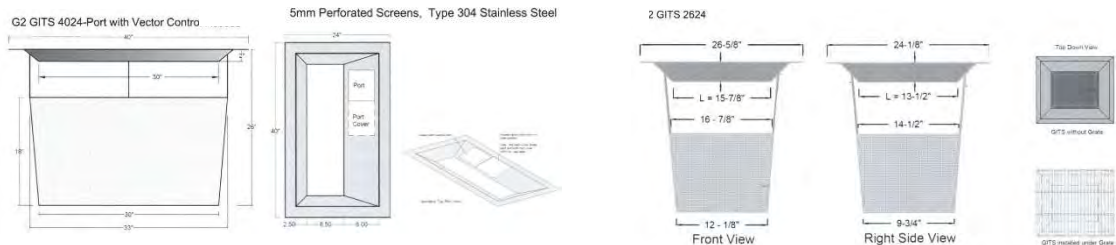

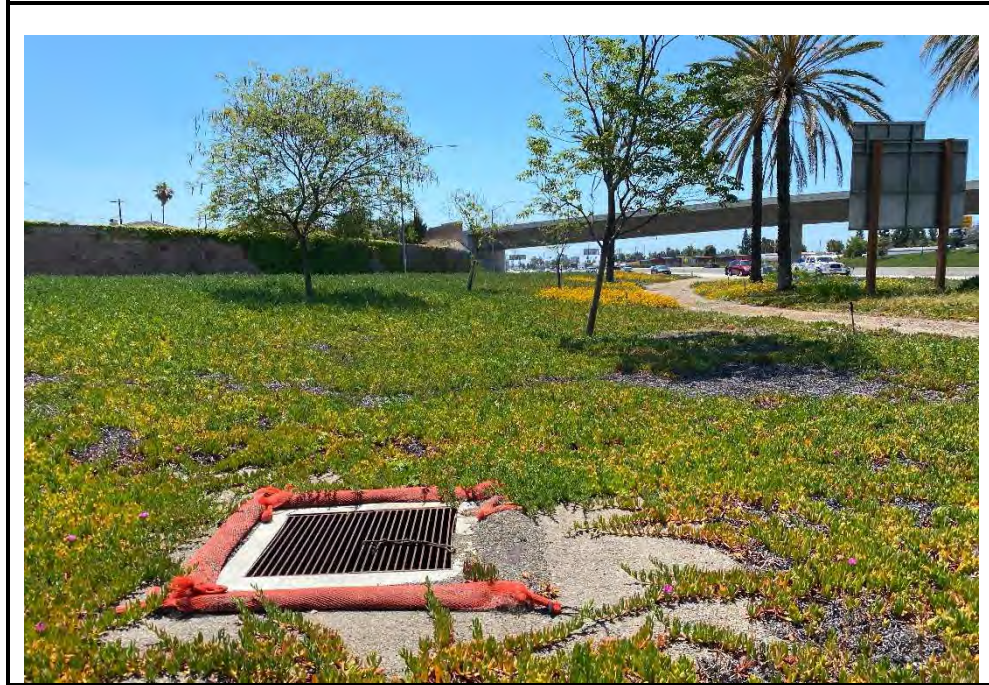

PHOTO A: Fill section with roadside vegetation strip slope flatter than 4:1 (diked/curbed, 10'-20" to ditch) (SOUTHWEST)



PHOTO B: Fill section with roadside vegetation strip slope flatter than 4:1 (diked/curbed, 10'-20" to ditch) (NORTHEAST)



**PHOTO C: Fill section with roadside vegetation strip slope flatter than 4:1
(diked/curbed, 10'-20" to ditch) (NORTHWEST)**



Site: 13 - Fill section with roadside vegetation strip slope flatter than 4:1 (sheet flow, 10'-20' to ditch)

Evaluation of Vegetation Effect on Discharge of Trash

Contract 43A0379, Task Order #14

Site Selection

GENERAL SITE INFORMATION: 13

District: 12	RWQCB: 8	City: Garden Grove	County: Orange
Location: 33.7688517018, -117.918911139		Route/PM: 22 / ORA R7.924	
Type of system: (Type 6) Fill section with roadside vegetation strip slope flatter than 4:1 (sheet flow, 10'-20' to ditch)			
Type of vegetation: Low lying grasses and perennials, recently maintained.			Vegetation cover: 80-100%
Tributary Drainage Area: 1.67 Acres (72,745 SF)		STGA Category: HIGH	

SITE EXHIBIT:

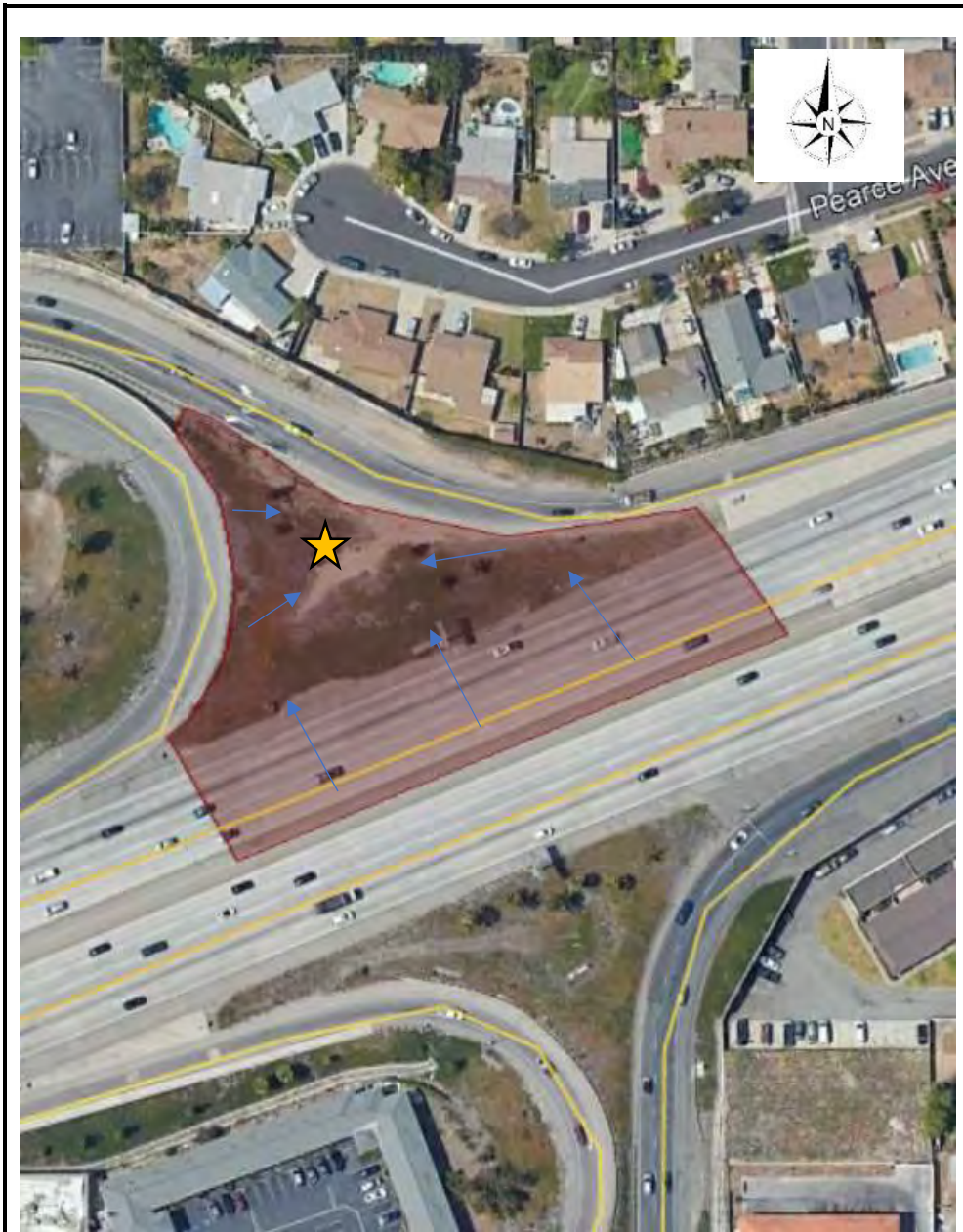

A



Site: 13 - Fill section with roadside vegetation strip slope flatter than 4:1 (sheet flow, 10'-20' to ditch)

Evaluation of Vegetation Effect on Discharge of Trash

Contract 43A0379, Task Order #14

Site Selection

GENERAL NOTES: Site is within a High Trash Generating Zone (Highway)

Safety Concerns:

- Accessing the proposed project site (3) was not observed to be a safety concern.
 - Project site is located in the westbound Harbor Blvd on-ramp/off-ramp infield area off the 22 freeway and is accessed from the right most lane (slow lane) of the 5 freeway in a paved shoulder.
 - Site can also be safely accessed from the Harbor Blvd westbound off-ramp from a shoulder in the left-most lane.
 - Project location is along in the on-ramp/off-ramp infield area and has good visibility for oncoming traffic.
 - Parking in the shoulder is adequate with approximately a 10' buffer from roadway and ability to pull over into vegetated shoulder, using vehicle as a physical barrier.
- Ponding is not anticipated to be a concern.

Site Access Details:

- Project site is located on the 22 freeway, in the Harbor Blvd westbound on-ramp/off-ramp infield area.
 - Project site is located in a vegetated infield area off the 22 freeway and is accessed from the right most lane (slow lane) of the 22 freeway or the left most lane of the westbound off-ramp.
 - Staff performing construction and monthly monitoring will park within the shoulder, away from road using vehicle as a physical barrier.

Security Concerns:

- Is the site subject to vandalism or theft? Yes No
 - Describe: No vandalism or theft concerns. Inlet insert is subsurface.
- Is the site subject to other damage (e.g., errant drivers)? Yes No
 - Describe: No preliminary concern over damage. Inlet insert is subsurface.

Maintenance Considerations:

- Project site (3) was recently maintained.
 - Vegetation was recently trimmed down.

Proposed Monitoring Device:

- One (1) catch basin insert is recommended.
 - An approved Caltrans full trash capture catch basin insert is recommended.
- Total volume of trash will be summed from trash collected within the proposed capture device.

Sample Drawings: G2 GITS™ for Inlets with Grates

Certified Full Capture Systems – California State Water Board



Site: 13 - Fill section with roadside vegetation strip slope flatter than 4:1 (sheet flow, 10'-20' to ditch)



PHOTO A: Fill section with roadside vegetation strip slope flatter than 4:1 (sheet flow, 10'-20' to ditch) (WEST)

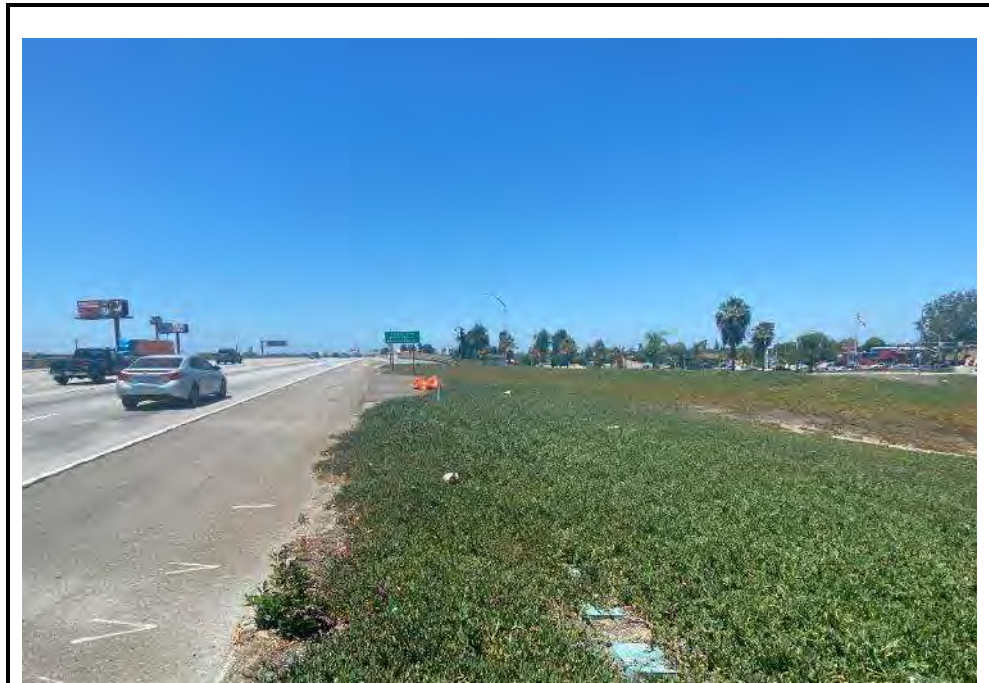

PHOTO B: Fill section with roadside vegetation strip slope flatter than 4:1 (sheet flow, 10'-20' to ditch) (SOUTHEAST)



Site: 13 - Fill section with roadside vegetation strip slope flatter than 4:1 (sheet flow, 10'-20' to ditch)



PHOTO C: Fill section with roadside vegetation strip slope flatter than 4:1 (sheet flow, 10'-20' to ditch) (NORTH)



Site: 14 - Fill section with roadside vegetation strip slope flatter than 4:1 (sheet flow, 5'-10' to ditch)

Evaluation of Vegetation Effect on Discharge of Trash

Contract 43A0379, Task Order #14

Site Selection

GENERAL SITE INFORMATION: 14

District: 12	RWQCB: 8	City: Anaheim	County: Orange
Location: 33.8395175014, -117.875612251		Route/PM: 57 / ORA 14.885	
Type of system: (Type 5) Fill section with roadside vegetation strip slope flatter than 4:1 (sheet flow, 5'-10' to ditch)			
Type of vegetation: Low lying grasses, trees, and shrubs, recently maintained.			Vegetation cover: 80-100%
Tributary Drainage Area: 2.20 Acres (95,832 SF)		STGA Category: HIGH	

SITE EXHIBIT:





Site: 14 - Fill section with roadside vegetation strip slope flatter than 4:1 (sheet flow, 5'-10' to ditch)

Evaluation of Vegetation Effect on Discharge of Trash

Contract 43A0379, Task Order #14

Site Selection

GENERAL NOTES: Site is within a High Trash Generating Zone (Highway)

Safety Concerns:

- Accessing the proposed project site (4) was not observed to be a safety concern.
 - Project site is located in the right shoulder of the northbound Lincoln Ave on-ramp of the 57 freeway and is accessed from the 57 northbound on-ramp.
 - Project location is along in the Lincoln Ave/57 freeway on-ramp and has good visibility for oncoming traffic.
 - Parking in the shoulder is adequate with approximately a 10' buffer from roadway in a wide dirt shoulder and ability to pull over further into the vegetated shoulder, using vehicle as a physical barrier.
- Ponding is not anticipated to be a concern.

Site Access Details:

- Project site is located on the 57 northbound on-ramp at Lincoln Ave.
 - Project site is located along the right shoulder of the northbound on-ramp and is accessed from the on-ramp.
 - Staff performing construction and monthly monitoring will park within the shoulder, away from road using vehicle as a physical barrier.

Security Concerns:

- Is the site subject to vandalism or theft? Yes No
 - Describe: No vandalism or theft concerns. Inlet insert is subsurface.
- Is the site subject to other damage (e.g., errant drivers)? Yes No
 - Describe: No preliminary concern over damage. Inlet insert is subsurface.

Maintenance Considerations:

- Project site (4) was recently maintained.
 - Vegetation was recently trimmed down.

Proposed Monitoring Device:

- One (1) catch basin insert is recommended.
 - An approved Caltrans full trash capture catch basin insert is recommended.
- Total volume of trash will be summed from trash collected within the proposed capture device.

Sample Drawings: G2 GITS™ for Inlets with Grates

Certified Full Capture Systems – California State Water Board





PHOTO A: Fill section with roadside vegetation strip slope flatter than 4:1 (sheet flow, 5'-10' to ditch) (NORTH)



PHOTO B: Fill section with roadside vegetation strip slope flatter than 4:1 (sheet flow, 5'-10' to ditch) (SOUTH)



Site: 14 - Fill section with roadside vegetation strip slope flatter than 4:1 (sheet flow, 5'-10' to ditch)



PHOTO C: Fill section with roadside vegetation strip slope flatter than 4:1 (sheet flow, 5'-10' to ditch) (NORTH)

Appendix B: Trash Inlet Insert Specs



GITS™ Drop-In CPS

Grated Inlet Trash Screen

State Water Board Certified FULL CAPTURE SYSTEM

G2 GITS™ grated inlet trash screen is a Full Capture System with 5mm perforations.

- Made from 304 Stainless Steel for extended life.
- Fits under any size inlet grate.
- Custom designed, fabricated & fitted to each grated inlet. "Made in California, USA"
- Sized to meet or exceed 1-year, 1-hour storm*.
- Professionally installed by G2 or by the customer.

Recommended for grated inlets.



info@g2construction.com
714.748.4242

www.G2construction.com
DBE, MBE & SBE Certified

Santa Ana
California



GITS™ Drop-In CPS

Grated Inlet Trash Screen

FULL CAPTURE SYSTEM Certified by the CA State Water Board & Regional Water Quality Control Boards

GITS™ Under Grate Trash Capture Device

Function:

- Captures all pollutants 5mm and larger that enter the inlet through the grate.
- Meets CA State Water Board trash regulation Track 1 requirements.
- Easy to install, clean and maintain.
- Pollutants prevented from exiting the inlet:
 - Primary: plastics (food containers, bags, bottles, straws); trash (paper, cigarette butts, cans); vegetative debris (leaves, branches, landscaping); other all other objects.
 - Secondary: pollutants absorbed by or attached to the Primary pollutants. Including from vehicles (hydrocarbons, fluids, copper, cadmium, zinc, tires, etc.), pathogens / bacteria, pesticides, nutrients, organic compounds, sediment toxicity, etc.

Design, Flexibility, & Approval:

- Custom designed and fabricated for each inlet and its unique features. Fits any grated inlet.
- Approved by State Water Board, Orange County DPW, OCTA, and agencies everywhere.

Material & Fabrication:

- Made of 304 stainless steel; 14 gauge with 5mm holes.
- "Made in California, USA"

Value:

- Low initial capital investment relative to other storm water quality BMPs. Lower long-term and total lifetime costs vs. any water quality BMP or taking no action.
- Requires no replacement filters or parts.

Public Outreach:

- Residents aware of the GITS installed in their local grated inlet perceive it to be an environmental benefit and demonstrates an environmentally conscious community.

Sample Drawings: G2 GITS™ for Inlets with Grates

Certified Full Capture Systems – California State Water Board

5mm Perforated Screens, Type 304 Stainless Steel

G2 GITS 4024-Port with Vector Control Access

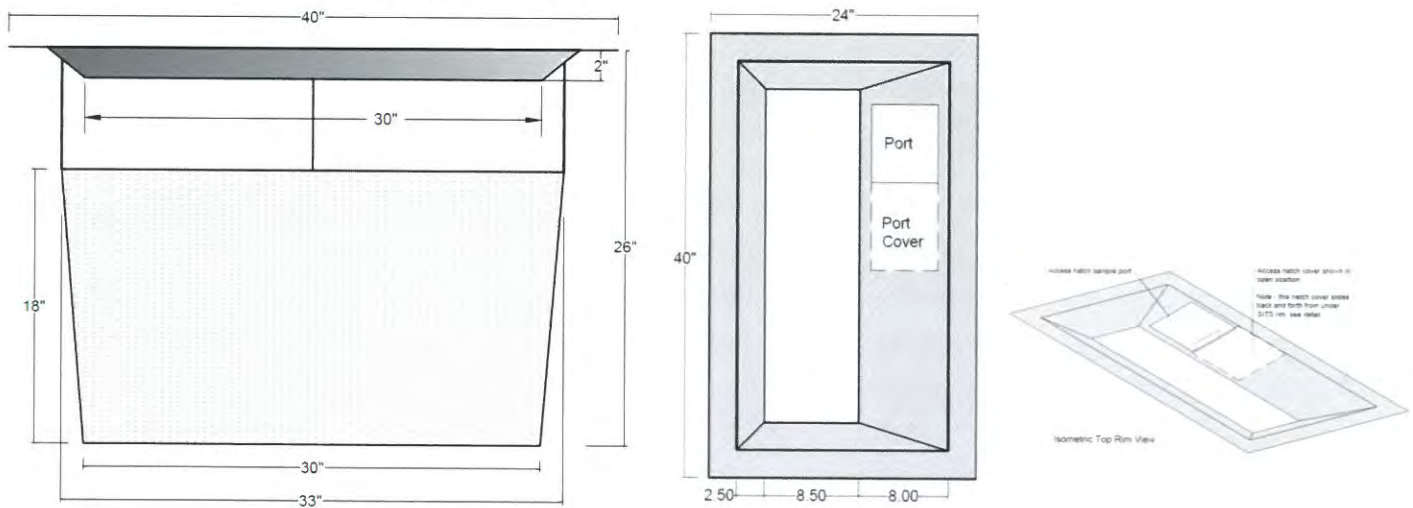

G2 GITS 2624

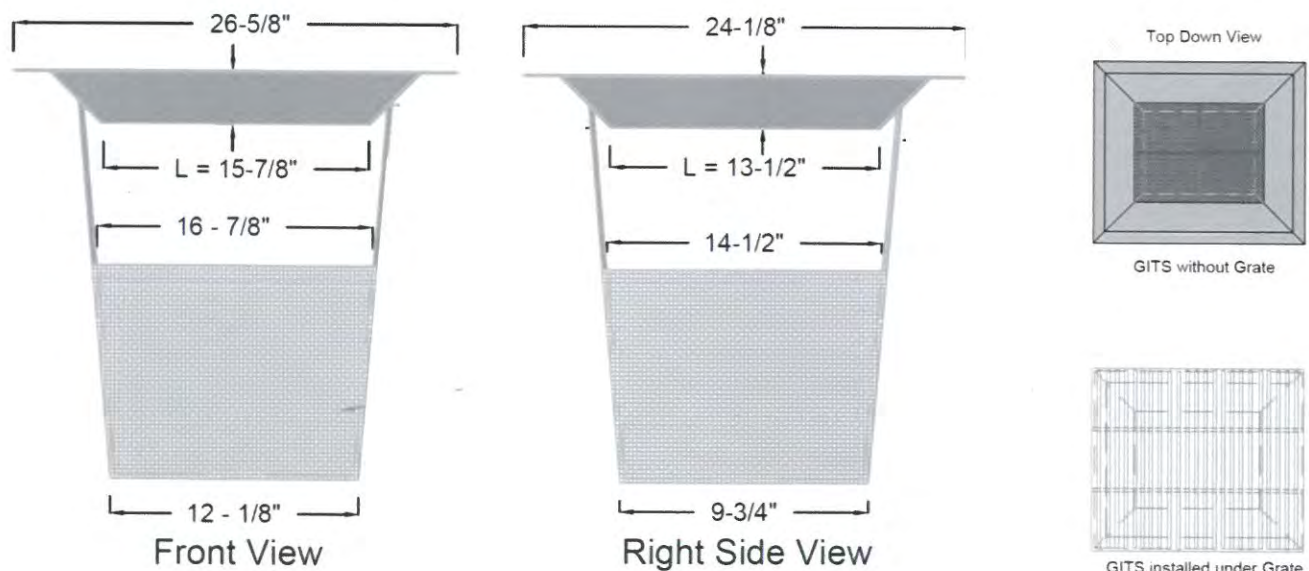



GITS™

Grated Inlet Trash Screen

CA State Waterboard Certified *FULL CAPTURE SYSTEM*

SIZES & MODELS

GITS™ Standard Models for Grated Inlets

Model #	Grate Length (in)	Screen Width (in)	Depth (in)	GITS Description
GITS 4024	40	24	custom	Rectangular top rim
GITS 4024-Port	40	24	custom	Rectangular top rim; with Vector Port
GITS 2624	26	24	custom	Rectangular top rim
GITS 2624-Port	26	24	custom	Rectangular top rim; with Vector Port
GITS 24R			custom	Circular top rim; 24" diameter

GITS™ Custom Design

Different sized grates. Custom design.

Irregular Inlets. Custom design.

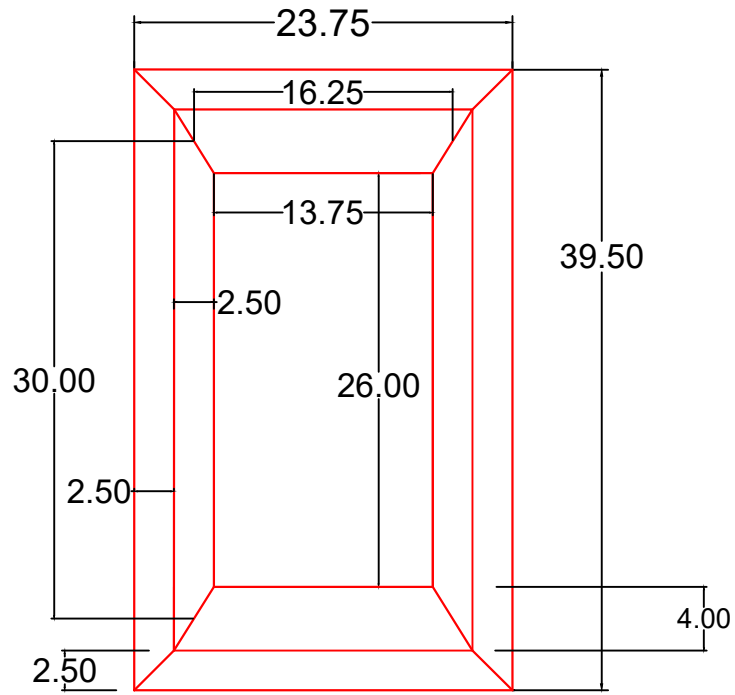

Top View

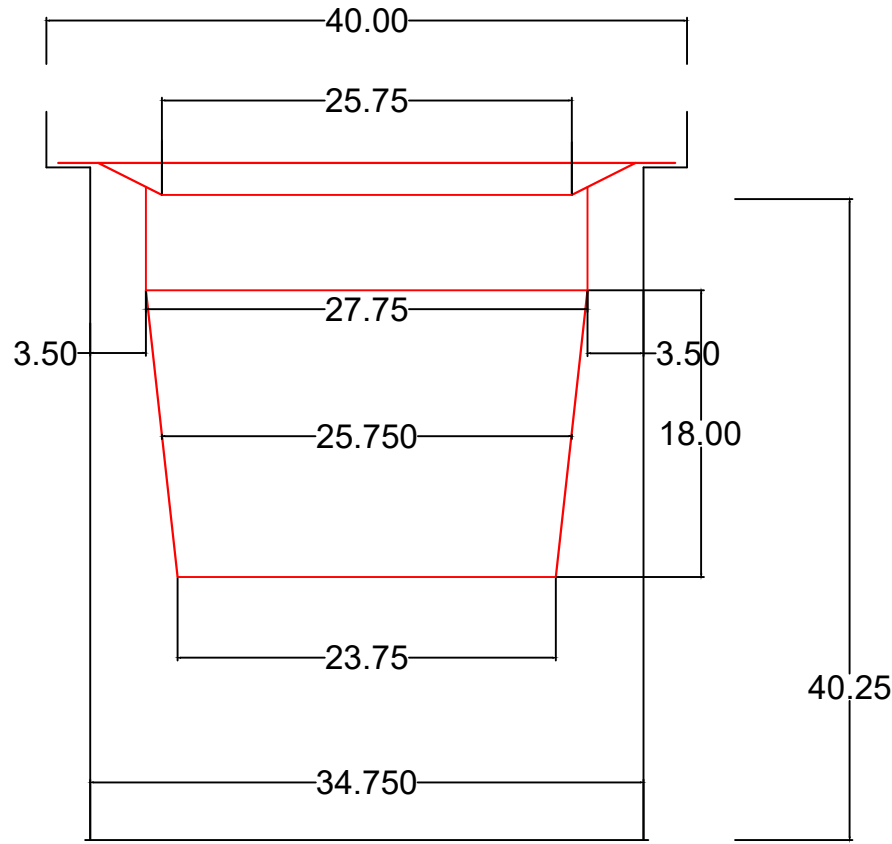

Side View

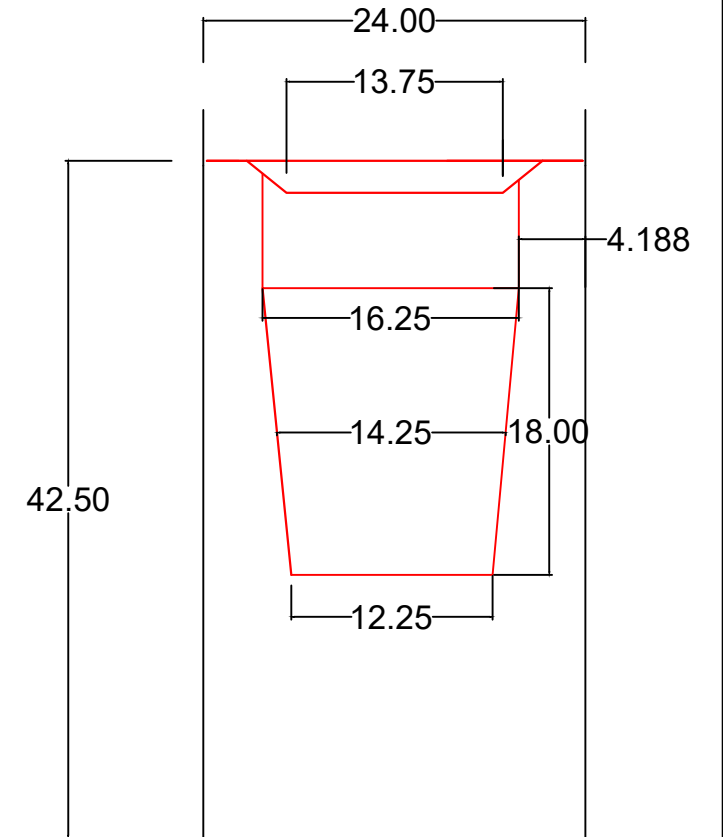

End View

This GITS profile covers a Caltrans profile 24" x 40" grated CB

The top rim dimensions were optimized to provide maximum water entry into capture basket. The entry opening = 2.48 sq. ft. The 6" vertical by pass at top of basket = 3.66 sq. ft., The horizontal overflow along top of basket adjacent to interior walls = 2.70 sq. ft.

The horizontal overflow pass through perimeter along the top of the debris basket to the interior CB walls is 9% greater than the entry point.

This profile optimizes the entry and overflow pass throughs.

The debris basket for this profile = 3.82 cu. ft.

Estimating debris weight at 30 lbs per cu. ft. = 115 lbs of debris + GITS weight of 29.47 lbs = total weight at 183.47 lbs.

This basket has 12 sq. ft of 5mm perforated screen. For a non-blocked surface this will provide 6 sq. ft. of treatment surface providing treatment up to 16 CFS.

Assembly Material Information

Rim weight at 16 gauge = 4.35 sq. ft. = 10.96 lbs

1/4" round bar...22' at .167 lbs per l.f. = 3.67 lbs

304 SS 5 mm perforated screen = 14.8 lbs

total weight.....= 29.47 lbs.

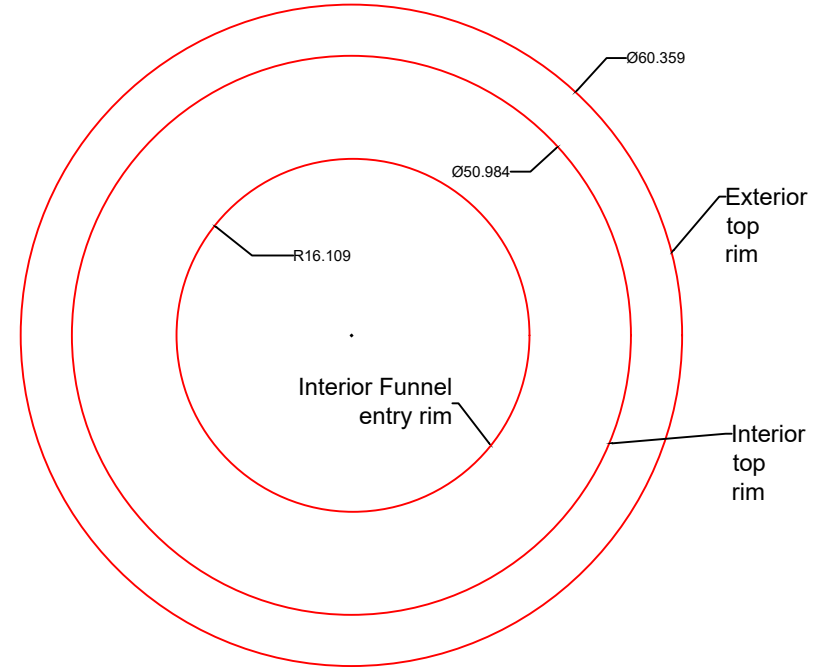
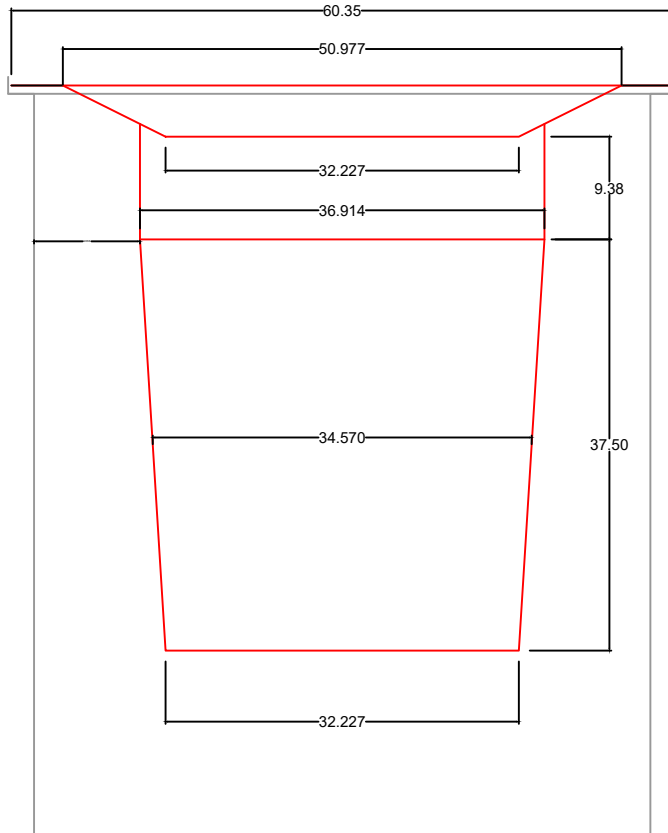

This GITS profile covers a Caltrans Circular 40" diameter grated inlet drain.

The top rim dimension is optimized to provide maximum water entry into capture basket. The entry opening = 2.31 sq. ft. The 6" vertical by pass at top of basket = 3.09 sq. ft., The horizontal overflow along top of basket adjacent to interior walls = 3.90 sq. ft.

The horizontal overflow pass through perimeter along the top of the debris basket to the interior CB walls is 69% greater than the entry point.

This profile optimizes the entry and overflow pass throughs.

The debris basket for this profile = 5.33 cu. ft.

Estimating debris weight at 30 lbs per cu. ft. = 160 lbs of debris + GITS weight of 44.15 lbs = total weight at 204.15 lbs.

This basket has 13.90 sq. ft of 5mm perforated screen. For a non-blocked surface this will provide 6.95 sq. ft. of treatment surface providing treatment up to 18.85 CFS.

Assembly Material Information

Rim weight at 16 gauge = 7.50 sq. ft. = 18.90 lbs
 304 SS 5 mm perforated screen
 16 sq.ft =25.25 lbs
 total weight.....= 44.15 lbs.

1) Length _____" (inches)

2) Width _____"

3) End Ledge (A) _____"

(B) _____"

4) Side Ledge (A) _____"

(B) _____"

5) Depth - bottom of grate frame
 to shallowest point of inlet _____"

6) Outlet Pipe Diameter _____"

6.1 Draw location of Outlet Pipe on Top Down View.

Stairs. Are there stairs? YES NO If Yes,

7.A) Bottom of grate to top of step _____"

7.B) Step extended from wall _____"

7.1 Draw location of Stairs on Top Down View.

IRREGULARITIES (If yes, explain & photo):

A) Is grate frame or ledge warped or non-rectangular?

B) Is there an Inlet Pipe?

C) Are there any obstructions in the inlet?

D) Is the grate irregular or have cut-outs?

E) Anything else irregular?

Photos Needed Showing: 1) Inlet & Surroundings, 2) Top Down with grate ledges, discharge pipe, stairs, 3) All irregularities

TOP DOWN VIEW

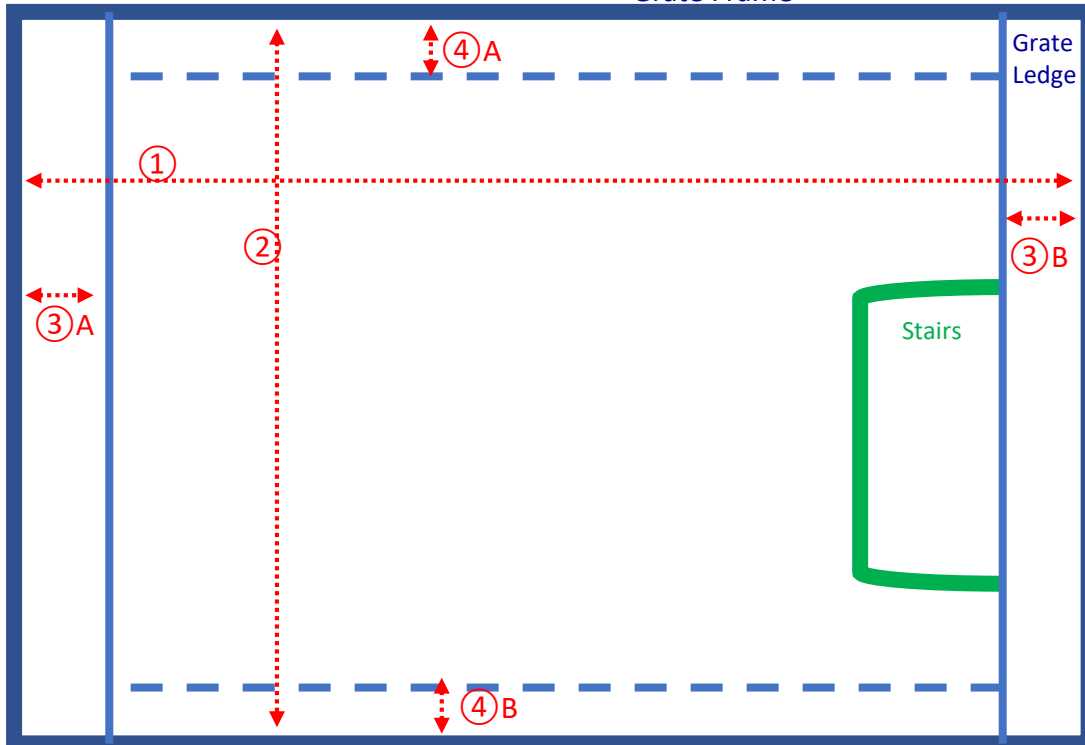

SIDE VIEW

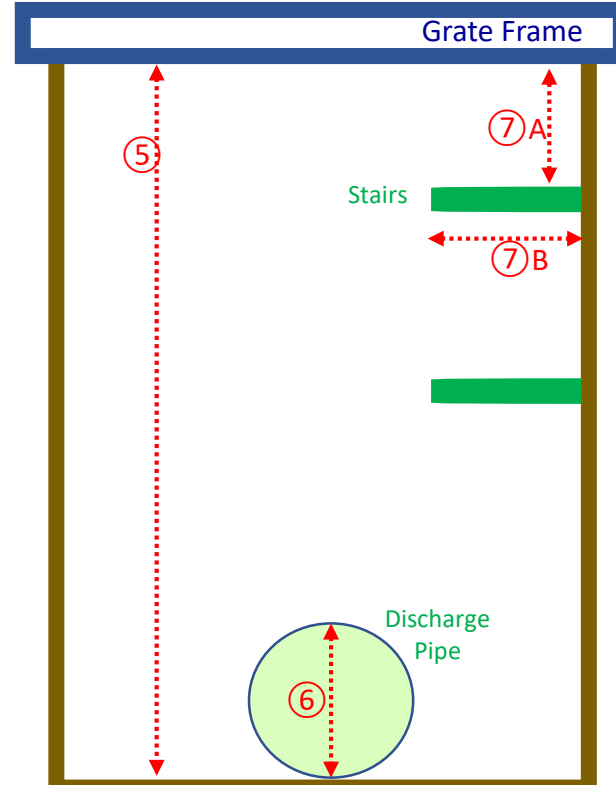

1) Length _____" (inches)

2) Width _____"

3) End Ledge (A) _____"

(B) _____"

4) Side Ledge (A) _____"

(B) _____"

5) Depth - bottom of grate frame
 to shallowest point of inlet _____"

6) Outlet Pipe Diameter _____"

6.1 Draw location of Outlet Pipe on Top Down View.

Stairs. Are there stairs? YES NO If Yes,

7.A) Bottom of grate to top of step _____"

7.B) Step extended from wall _____"

7.1 Draw location of Stairs on Top Down View.

IRREGULARITIES (If yes, explain & photo):

A) Is grate frame or ledge warped or non-rectangular?

B) Is there an Inlet Pipe?

C) Are there any obstructions in the inlet?

D) Is the grate irregular or have cut-outs?

E) Anything else irregular?

Photos Needed Showing: 1) Inlet & Surroundings, 2) Top Down with grate ledges, discharge pipe, stairs, 3) All irregularities

TOP DOWN VIEW

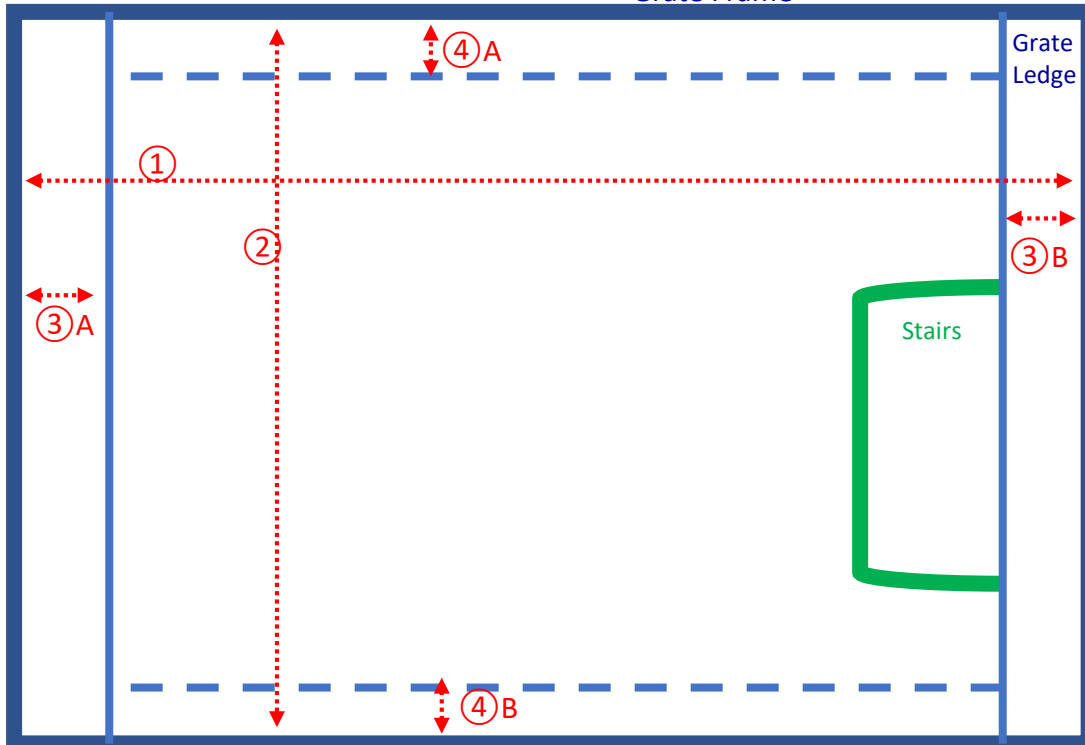

SIDE VIEW

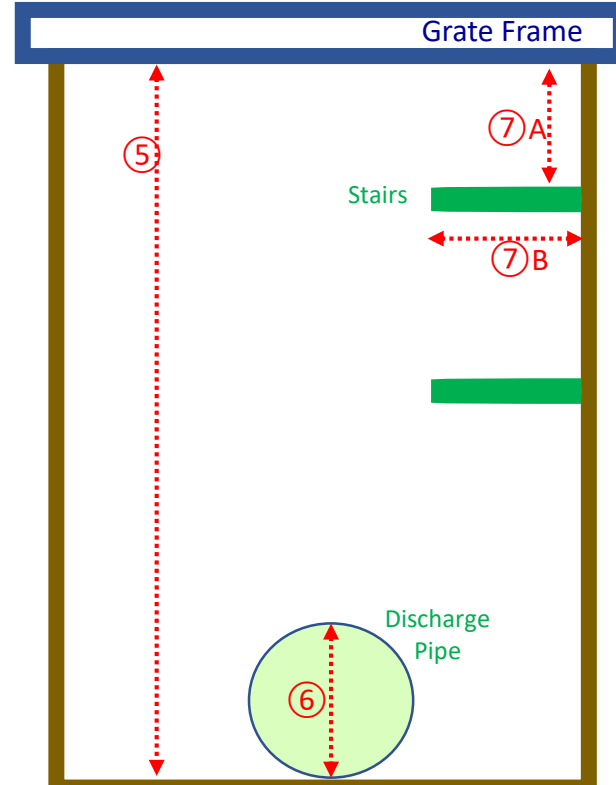

1) Length _____" (inches)

2) Width _____"

3) End Ledge (A) _____"

(B) _____"

4) Side Ledge (A) _____"

(B) _____"

5) Depth - bottom of grate frame
 to shallowest point of inlet _____"

6) Outlet Pipe Diameter _____"

6.1 Draw location of Outlet Pipe on Top Down View.

Stairs. Are there stairs? YES NO If Yes,

7.A) Bottom of grate to top of step _____"

7.B) Step extended from wall _____"

7.1 Draw location of Stairs on Top Down View.

IRREGULARITIES (If yes, explain & photo):

A) Is grate frame or ledge warped or non-rectangular?

B) Is there an Inlet Pipe?

C) Are there any obstructions in the inlet?

D) Is the grate irregular or have cut-outs?

E) Anything else irregular?

Photos Needed Showing: 1) Inlet & Surroundings, 2) Top Down with grate ledges, discharge pipe, stairs, 3) All irregularities

TOP DOWN VIEW

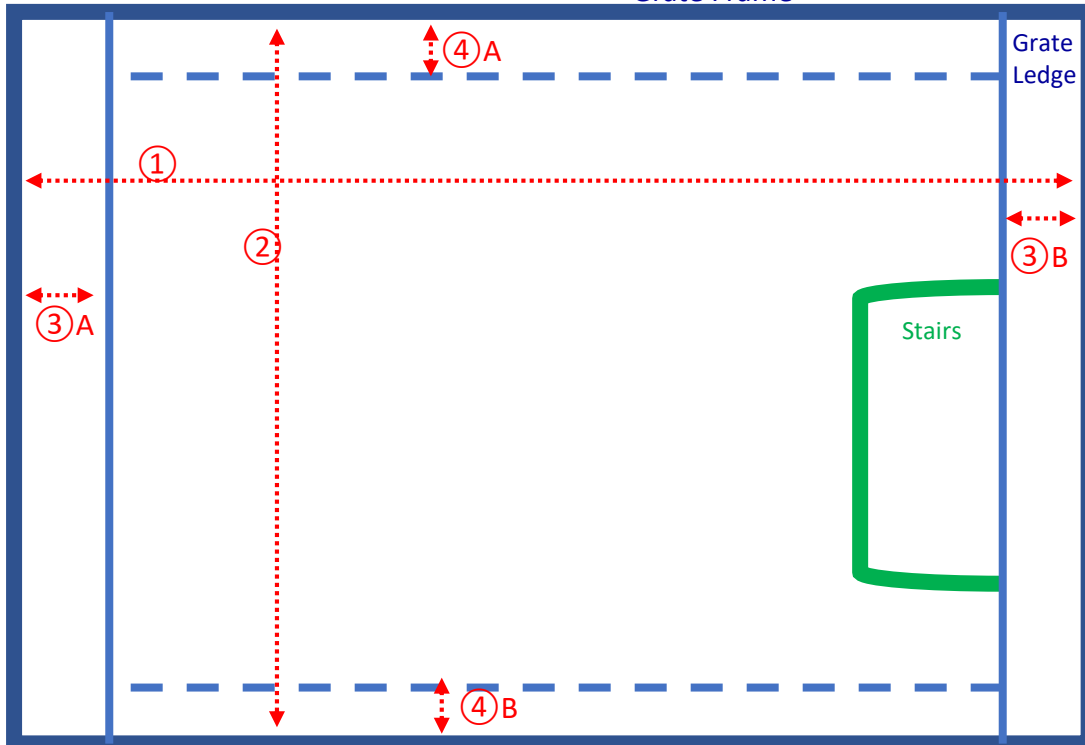

SIDE VIEW

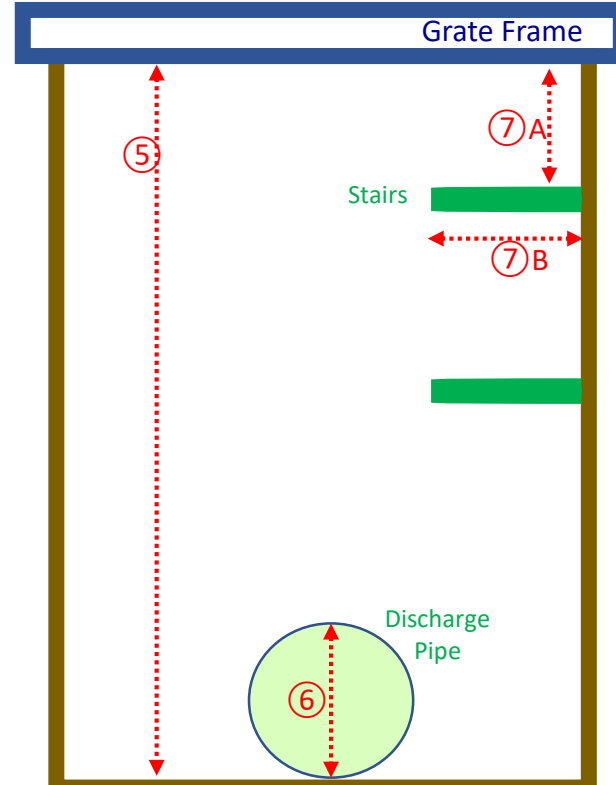

1) Length _____" (inches)

2) Width _____"

3) End Ledge (A) _____"

(B) _____"

4) Side Ledge (A) _____"

(B) _____"

5) Depth - bottom of grate frame
 to shallowest point of inlet _____"

6) Outlet Pipe Diameter _____"

6.1 Draw location of Outlet Pipe on Top Down View.

Stairs. Are there stairs? YES NO If Yes,

7.A) Bottom of grate to top of step _____"

7.B) Step extended from wall _____"

7.1 Draw location of Stairs on Top Down View.

IRREGULARITIES (If yes, explain & photo):

A) Is grate frame or ledge warped or non-rectangular?

B) Is there an Inlet Pipe?

C) Are there any obstructions in the inlet?

D) Is the grate irregular or have cut-outs?

E) Anything else irregular?

Photos Needed Showing: 1) Inlet & Surroundings, 2) Top Down with grate ledges, discharge pipe, stairs, 3) All irregularities

TOP DOWN VIEW

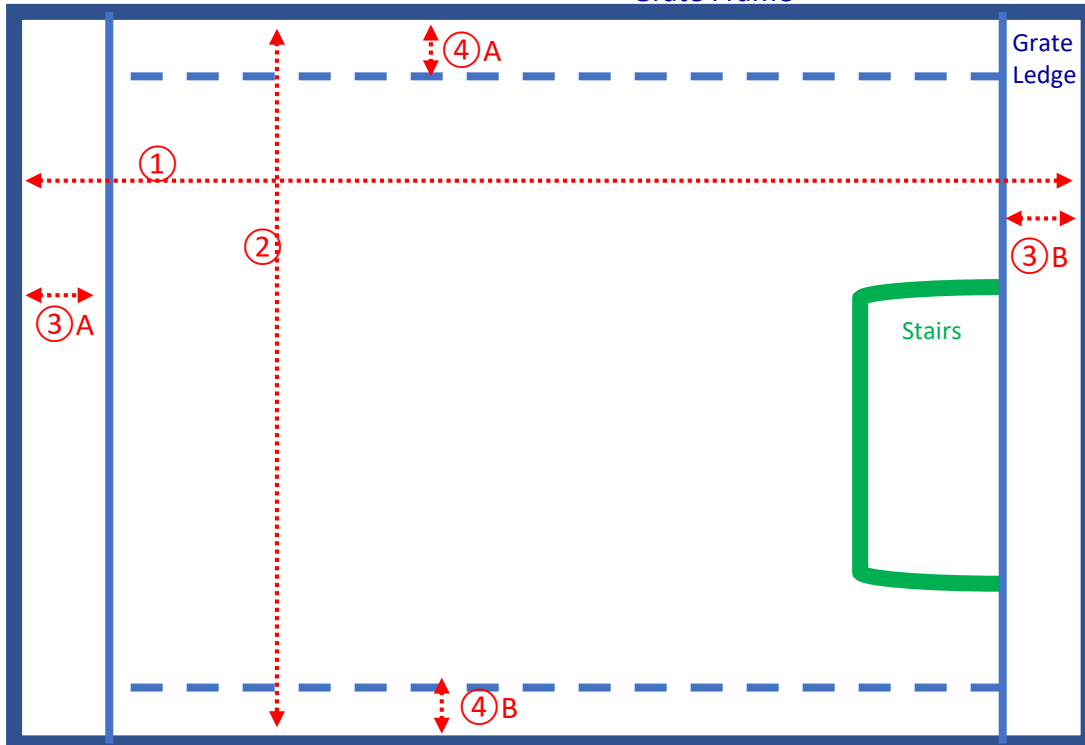

SIDE VIEW

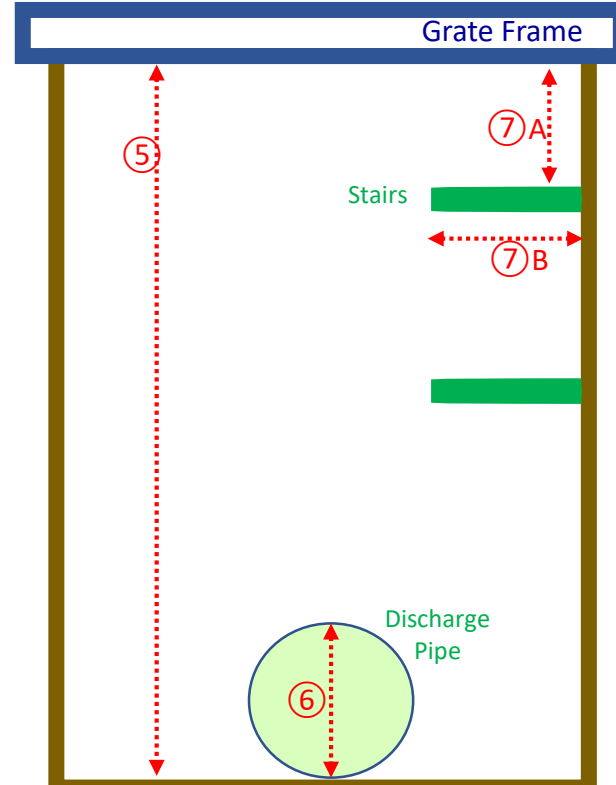

1) Length _____" (inches)

2) Width _____"

3) End Ledge (A) _____"

(B) _____"

4) Side Ledge (A) _____"

(B) _____"

5) Depth - bottom of grate frame
 to shallowest point of inlet _____"

6) Outlet Pipe Diameter _____"

6.1 Draw location of Outlet Pipe on Top Down View.

Stairs. Are there stairs? YES NO If Yes,

7.A) Bottom of grate to top of step _____"

7.B) Step extended from wall _____"

7.1 Draw location of Stairs on Top Down View.

IRREGULARITIES (If yes, explain & photo):

A) Is grate frame or ledge warped or non-rectangular?

B) Is there an Inlet Pipe?

C) Are there any obstructions in the inlet?

D) Is the grate irregular or have cut-outs?

E) Anything else irregular?

Photos Needed Showing: 1) Inlet & Surroundings, 2) Top Down with grate ledges, discharge pipe, stairs, 3) All irregularities

TOP DOWN VIEW

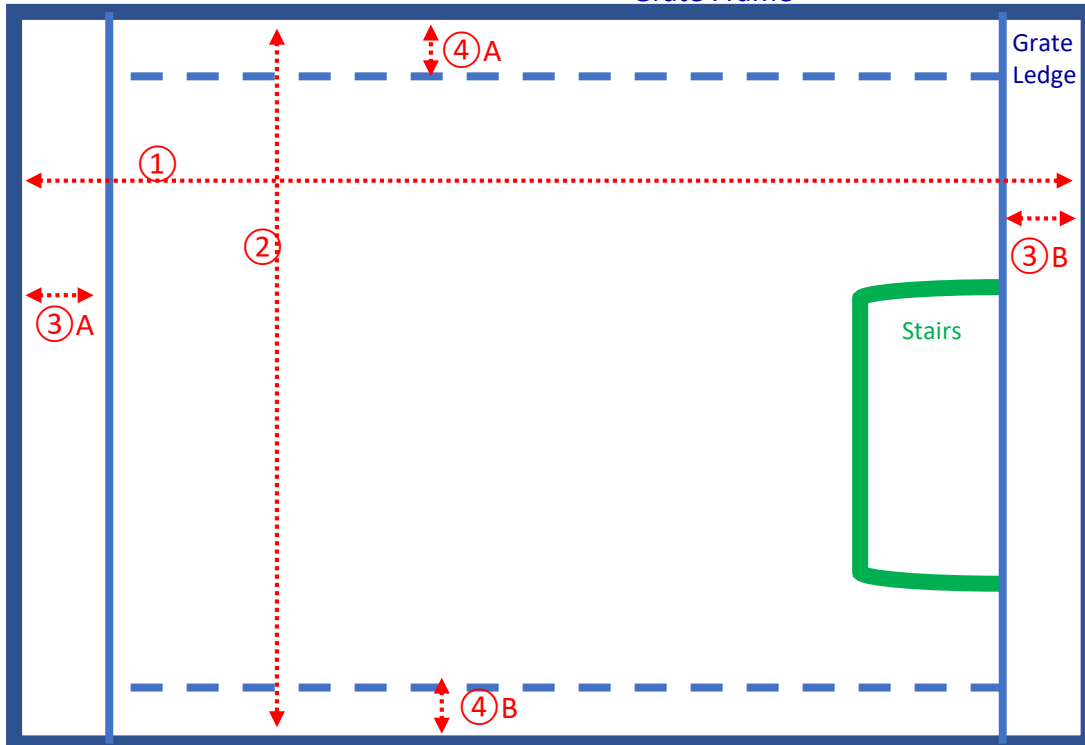

SIDE VIEW

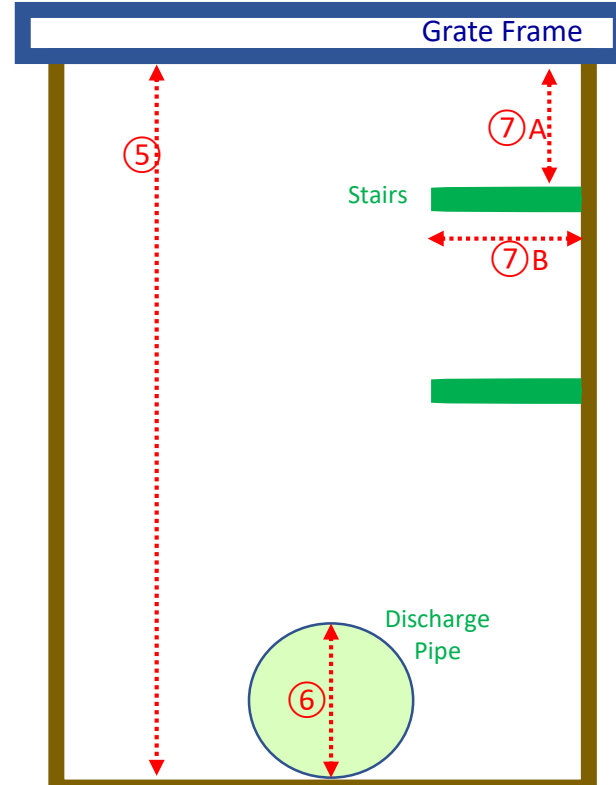

1) Length _____" (inches)

2) Width _____"

3) End Ledge (A) _____"

(B) _____"

4) Side Ledge (A) _____"

(B) _____"

5) Depth - bottom of grate frame
 to shallowest point of inlet _____"

6) Outlet Pipe Diameter _____"

6.1 Draw location of Outlet Pipe on Top Down View.

Stairs. Are there stairs? YES NO If Yes,

7.A) Bottom of grate to top of step _____"

7.B) Step extended from wall _____"

7.1 Draw location of Stairs on Top Down View.

IRREGULARITIES (If yes, explain & photo):

A) Is grate frame or ledge warped or non-rectangular?

B) Is there an Inlet Pipe?

C) Are there any obstructions in the inlet?

D) Is the grate irregular or have cut-outs?

E) Anything else irregular?

Photos Needed Showing: 1) Inlet & Surroundings, 2) Top Down with grate ledges, discharge pipe, stairs, 3) All irregularities

TOP DOWN VIEW

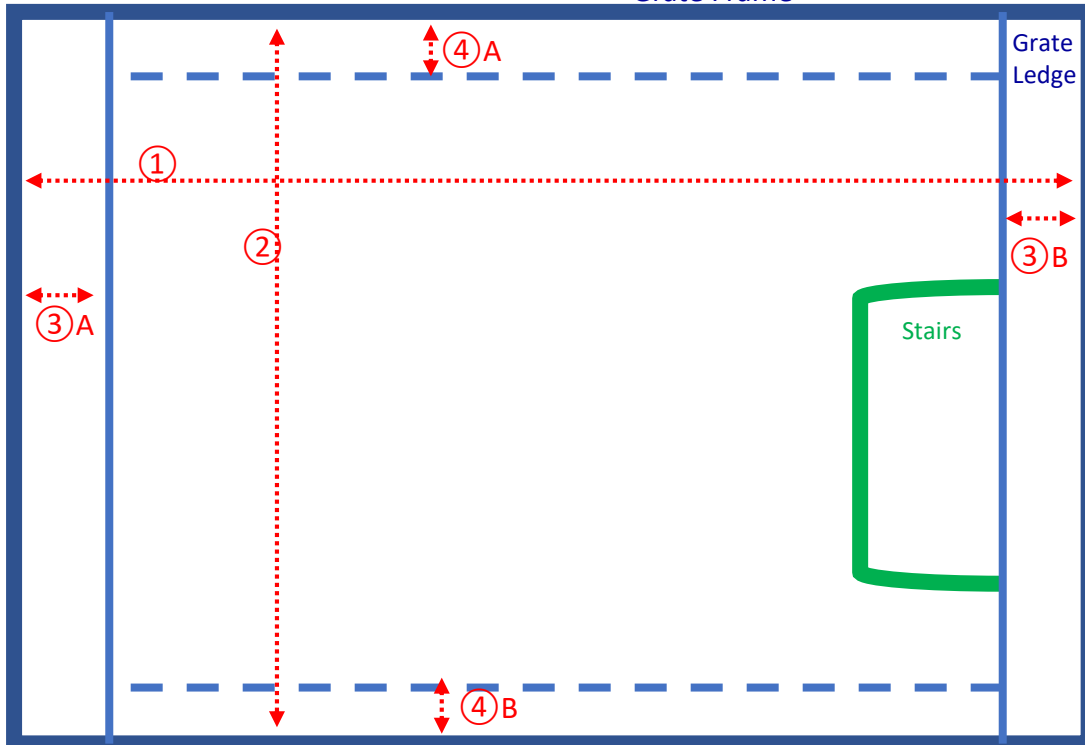

SIDE VIEW

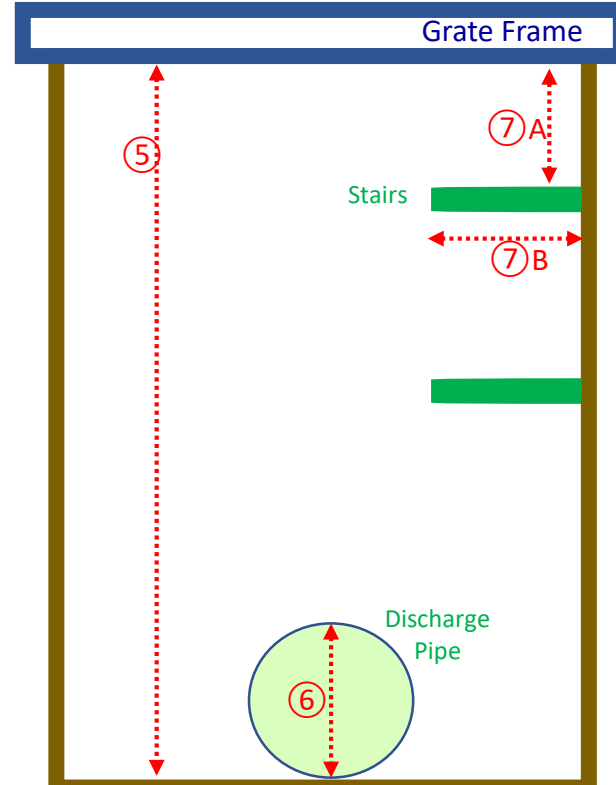

1) Length _____" (inches)

2) Width _____"

3) End Ledge (A) _____"

(B) _____"

4) Side Ledge (A) _____"

(B) _____"

5) Depth - bottom of grate frame
 to shallowest point of inlet _____"

6) Outlet Pipe Diameter _____"

6.1 Draw location of Outlet Pipe on Top Down View.

Stairs. Are there stairs? YES NO If Yes,

7.A) Bottom of grate to top of step _____"

7.B) Step extended from wall _____"

7.1 Draw location of Stairs on Top Down View.

IRREGULARITIES (If yes, explain & photo):

A) Is grate frame or ledge warped or non-rectangular?

B) Is there an Inlet Pipe?

C) Are there any obstructions in the inlet?

D) Is the grate irregular or have cut-outs?

E) Anything else irregular?

Photos Needed Showing: 1) Inlet & Surroundings, 2) Top Down with grate ledges, discharge pipe, stairs, 3) All irregularities

TOP DOWN VIEW

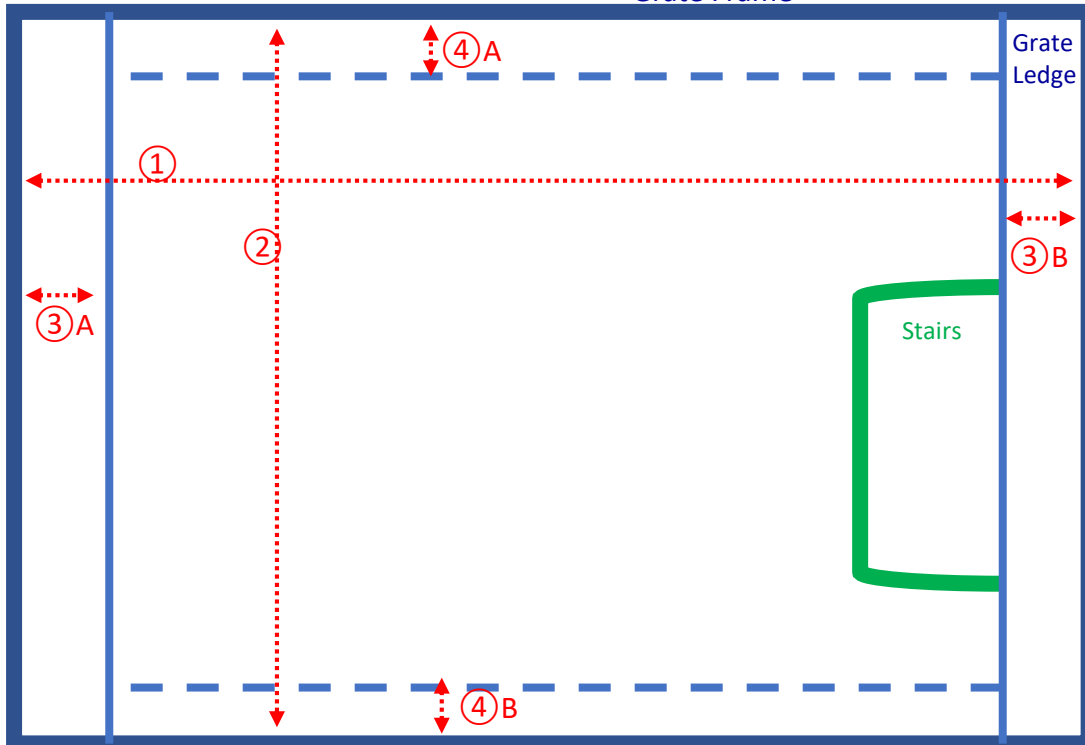

SIDE VIEW

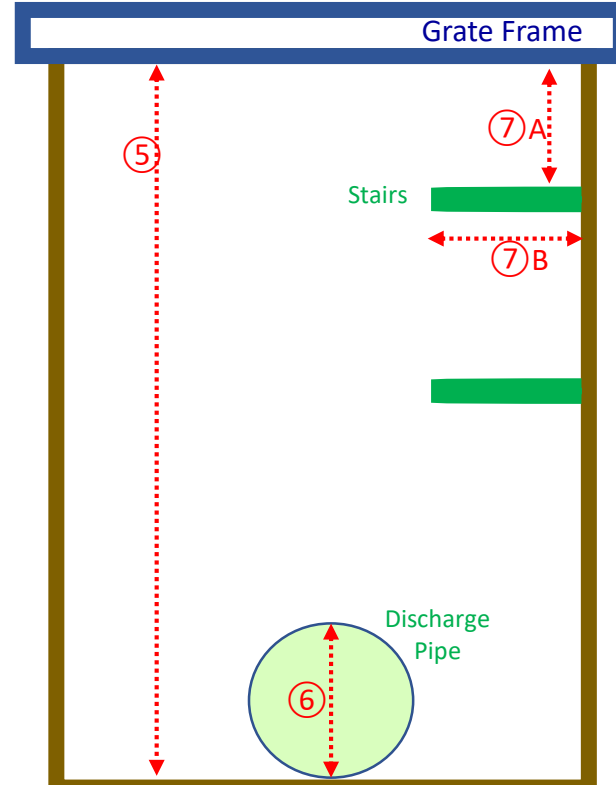

1) Length _____" (inches)

2) Width _____"

3) End Ledge (A) _____"

(B) _____"

4) Side Ledge (A) _____"

(B) _____"

5) Depth - bottom of grate frame
 to shallowest point of inlet _____"

6) Outlet Pipe Diameter _____"

6.1 Draw location of Outlet Pipe on Top Down View.

Stairs. Are there stairs? YES NO If Yes,

7.A) Bottom of grate to top of step _____"

7.B) Step extended from wall _____"

7.1 Draw location of Stairs on Top Down View.

IRREGULARITIES (If yes, explain & photo):

A) Is grate frame or ledge warped or non-rectangular?

B) Is there an Inlet Pipe?

C) Are there any obstructions in the inlet?

D) Is the grate irregular or have cut-outs?

E) Anything else irregular?

Photos Needed Showing: 1) Inlet & Surroundings, 2) Top Down with grate ledges, discharge pipe, stairs, 3) All irregularities

TOP DOWN VIEW

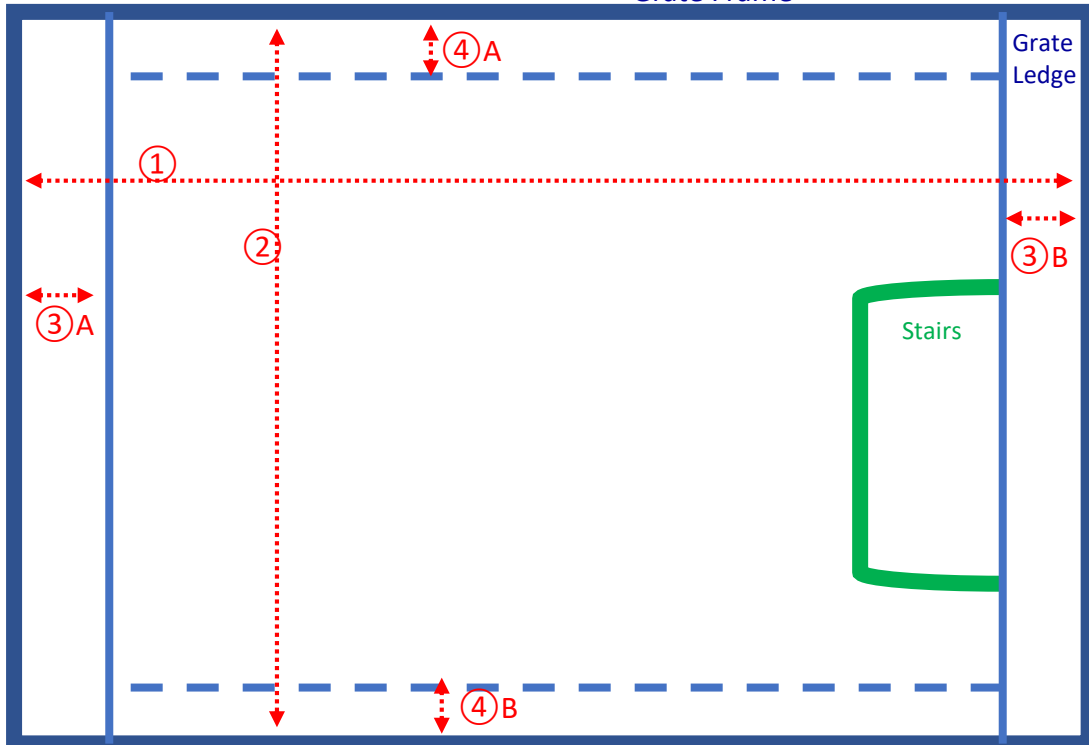

SIDE VIEW

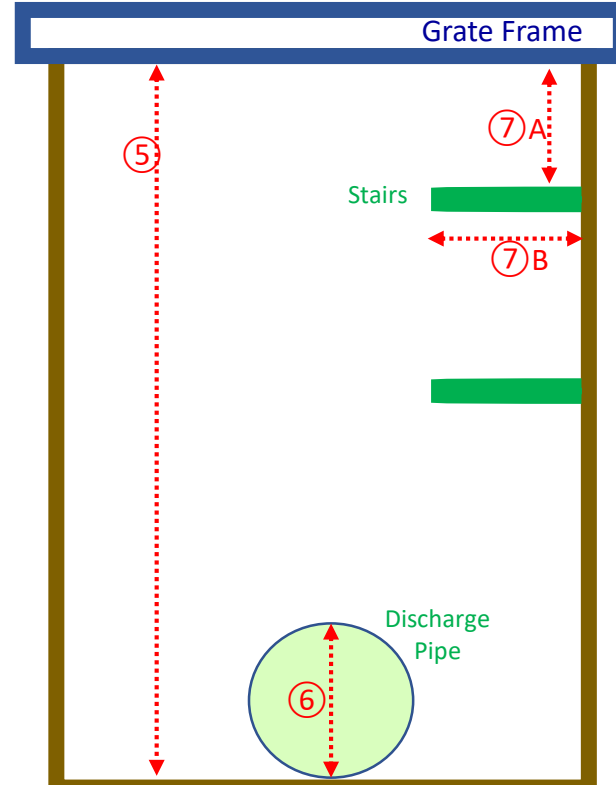

- 1) Length _____" (inches)
- 2) Width _____"
- 3) End Ledge (A) _____"
(B) _____"
- 4) Side Ledge (A) _____"
(B) _____"
- 5) Depth - bottom of grate frame
to shallowest point of inlet _____"
- 6) Outlet Pipe Diameter _____"
- 6.1 Draw location of Outlet Pipe on Top Down View.
- Stairs. Are there stairs? YES NO If Yes,
- 7.A) Bottom of grate to top of step _____"
- 7.B) Step extended from wall _____"
- 7.1 Draw location of Stairs on Top Down View.

- IRREGULARITIES** (If yes, explain & photo):
- A) Is grate frame or ledge warped or non-rectangular?
 - B) Is there an Inlet Pipe?
 - C) Are there any obstructions in the inlet?
 - D) Is the grate irregular or have cut-outs?
 - E) Anything else irregular?

Photos Needed Showing: 1) Inlet & Surroundings, 2) Top Down with grate ledges, discharge pipe, stairs, 3) All irregularities

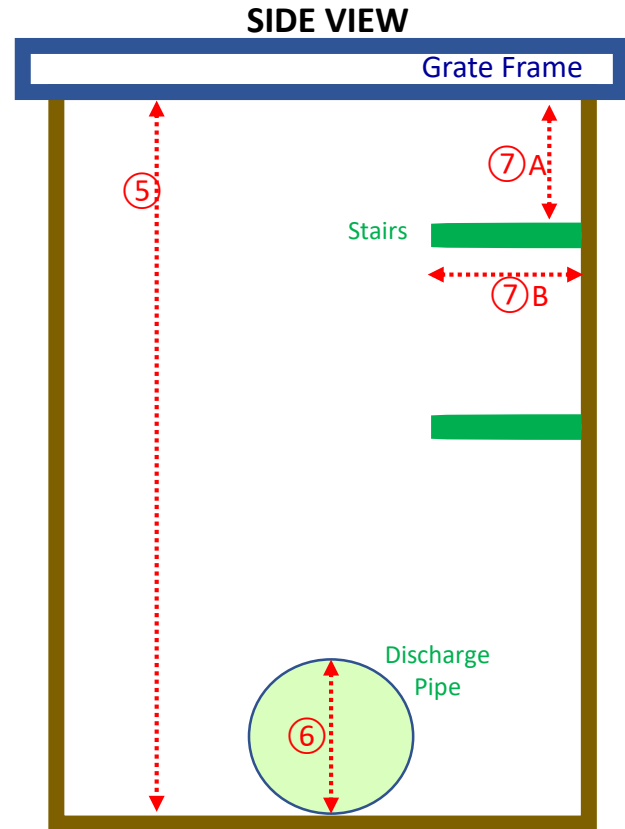
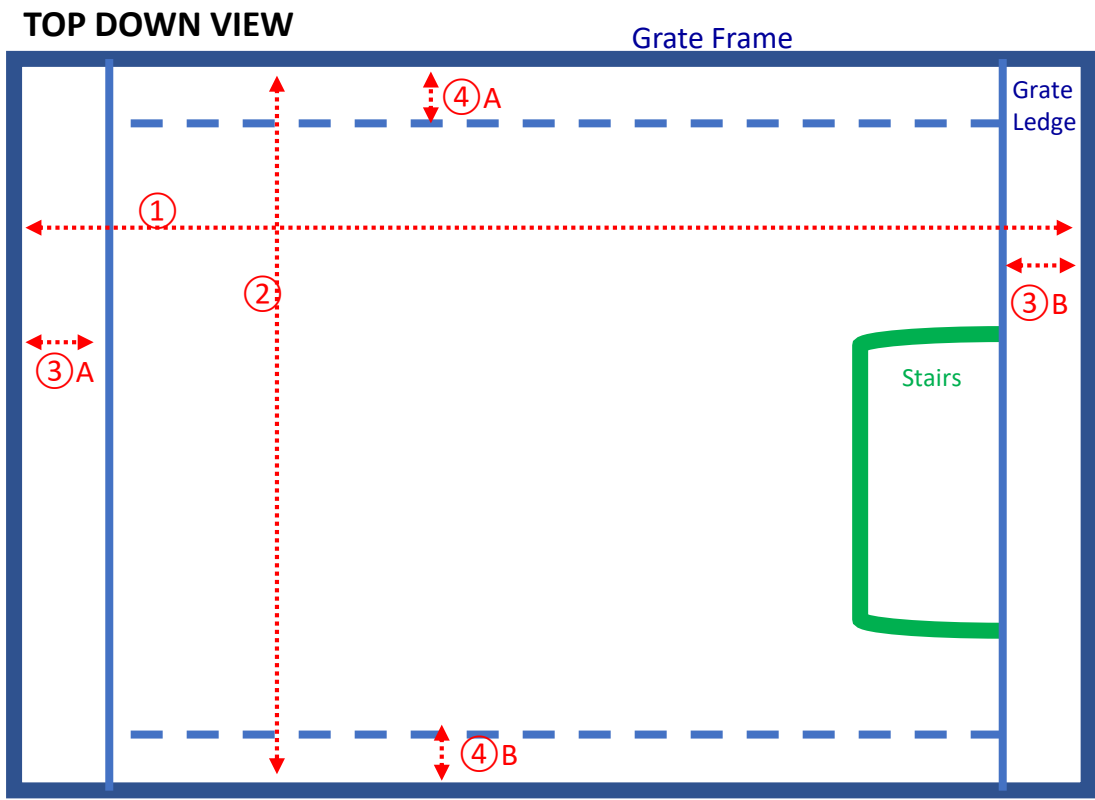

1) Length _____" (inches)

2) Width _____"

3) End Ledge (A) _____"

(B) _____"

4) Side Ledge (A) _____"

(B) _____"

5) Depth - bottom of grate frame
 to shallowest point of inlet _____"

6) Outlet Pipe Diameter _____"

6.1 Draw location of Outlet Pipe on Top Down View.

Stairs. Are there stairs? YES NO If Yes,

7.A) Bottom of grate to top of step _____"

7.B) Step extended from wall _____"

7.1 Draw location of Stairs on Top Down View.

IRREGULARITIES (If yes, explain & photo):

A) Is grate frame or ledge warped or non-rectangular?

B) Is there an Inlet Pipe?

C) Are there any obstructions in the inlet?

D) Is the grate irregular or have cut-outs?

E) Anything else irregular?

Photos Needed Showing: 1) Inlet & Surroundings, 2) Top Down with grate ledges, discharge pipe, stairs, 3) All irregularities

TOP DOWN VIEW

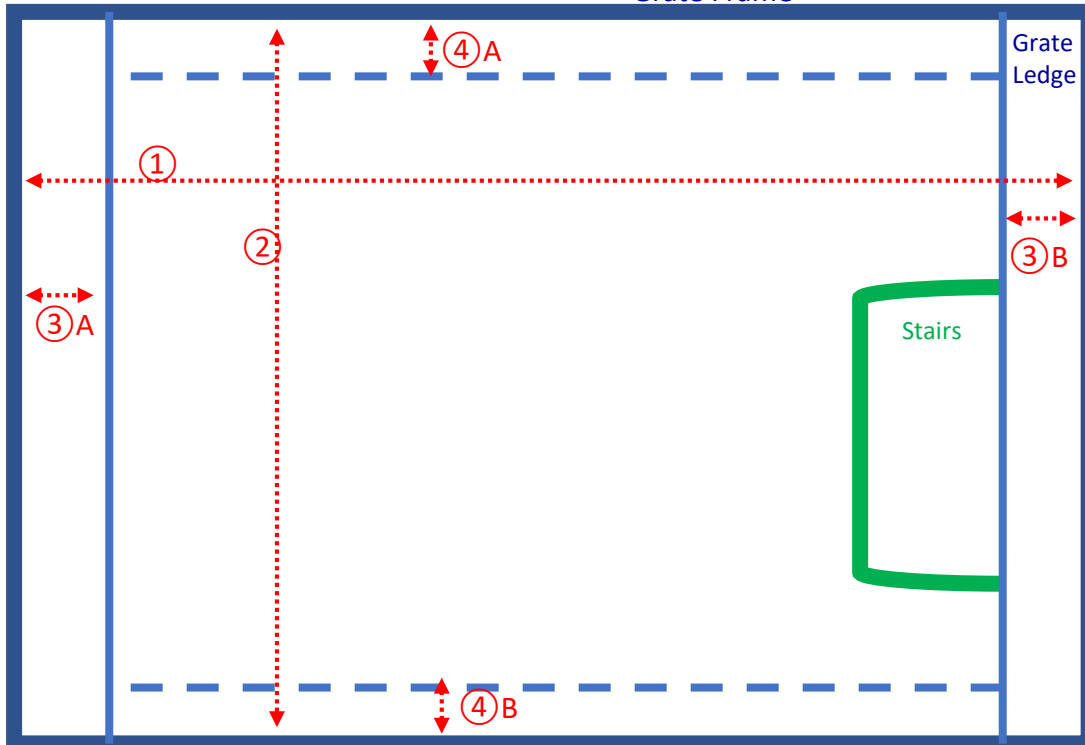

SIDE VIEW

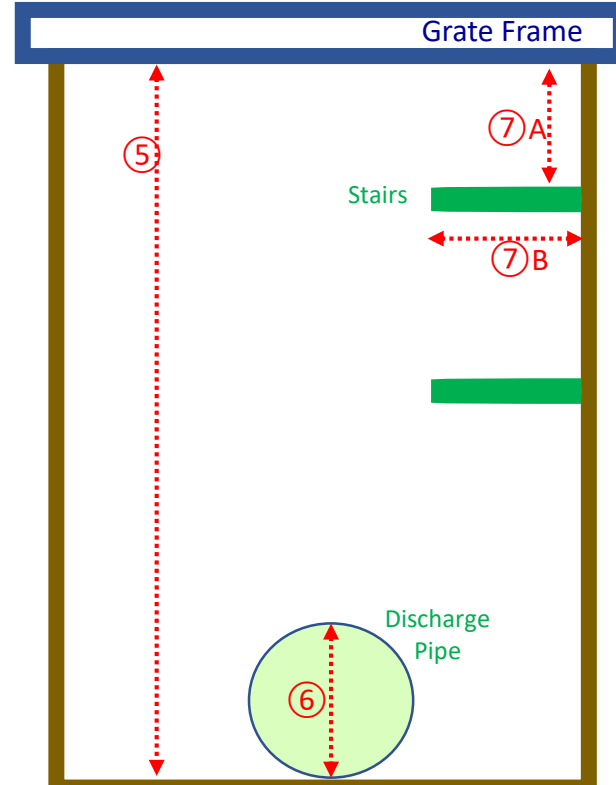

1) Length _____" (inches)

2) Width _____"

3) End Ledge (A) _____"

(B) _____"

4) Side Ledge (A) _____"

(B) _____"

5) Depth - bottom of grate frame
 to shallowest point of inlet _____"

6) Outlet Pipe Diameter _____"

6.1 Draw location of Outlet Pipe on Top Down View.

Stairs. Are there stairs? YES NO If Yes,

7.A) Bottom of grate to top of step _____"

7.B) Step extended from wall _____"

7.1 Draw location of Stairs on Top Down View.

IRREGULARITIES (If yes, explain & photo):

A) Is grate frame or ledge warped or non-rectangular?

B) Is there an Inlet Pipe?

C) Are there any obstructions in the inlet?

D) Is the grate irregular or have cut-outs?

E) Anything else irregular?

Photos Needed Showing: 1) Inlet & Surroundings, 2) Top Down with grate ledges, discharge pipe, stairs, 3) All irregularities

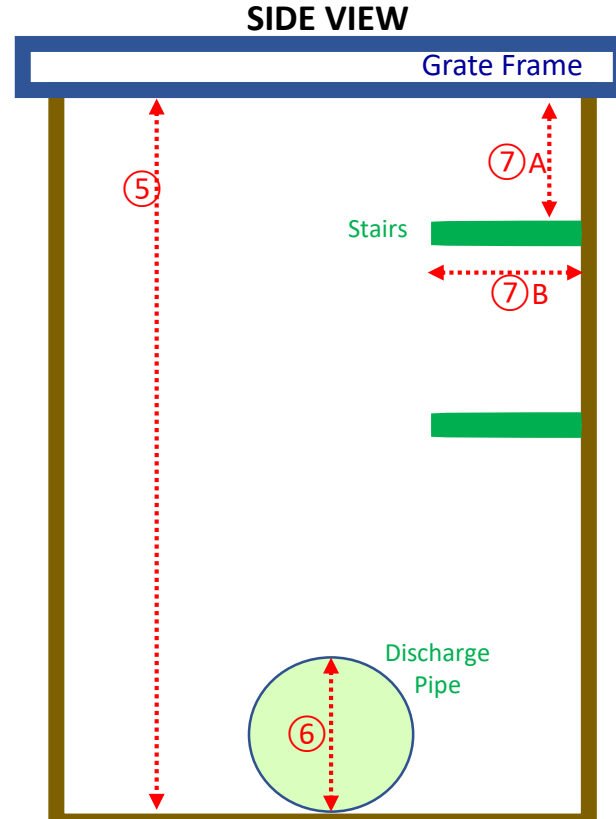
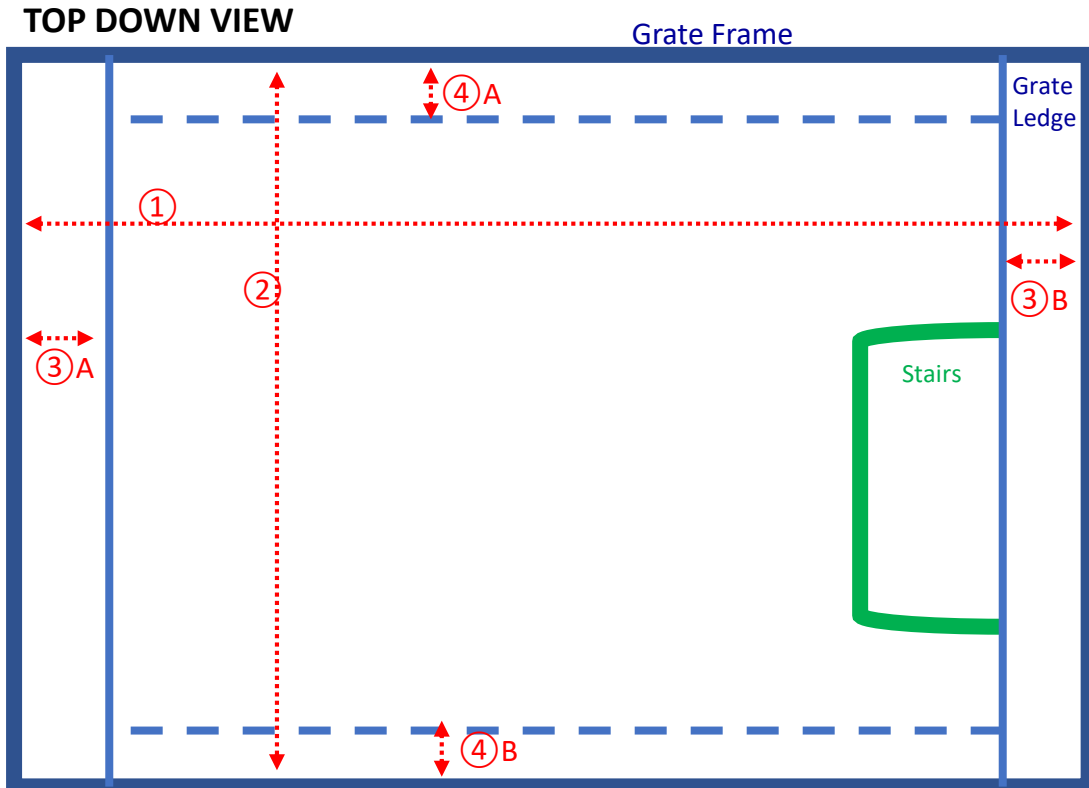

1) Length _____" (inches)

2) Width _____"

3) End Ledge (A) _____"

(B) _____"

4) Side Ledge (A) _____"

(B) _____"

5) Depth - bottom of grate frame
 to shallowest point of inlet _____"

6) Outlet Pipe Diameter _____"

6.1 Draw location of Outlet Pipe on Top Down View.

Stairs. Are there stairs? YES NO If Yes,

7.A) Bottom of grate to top of step _____"

7.B) Step extended from wall _____"

7.1 Draw location of Stairs on Top Down View.

IRREGULARITIES (If yes, explain & photo):

A) Is grate frame or ledge warped or non-rectangular?

B) Is there an Inlet Pipe?

C) Are there any obstructions in the inlet?

D) Is the grate irregular or have cut-outs?

E) Anything else irregular?

Photos Needed Showing: 1) Inlet & Surroundings, 2) Top Down with grate ledges, discharge pipe, stairs, 3) All irregularities

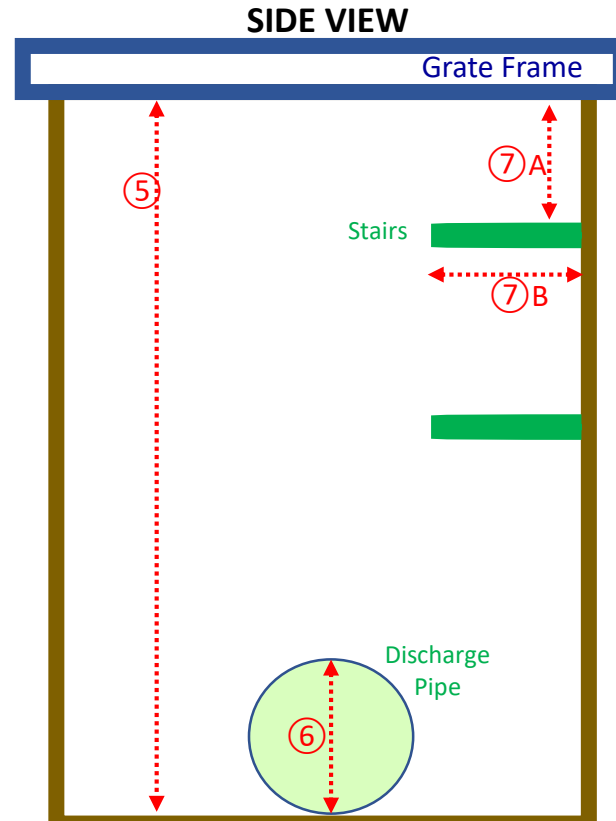
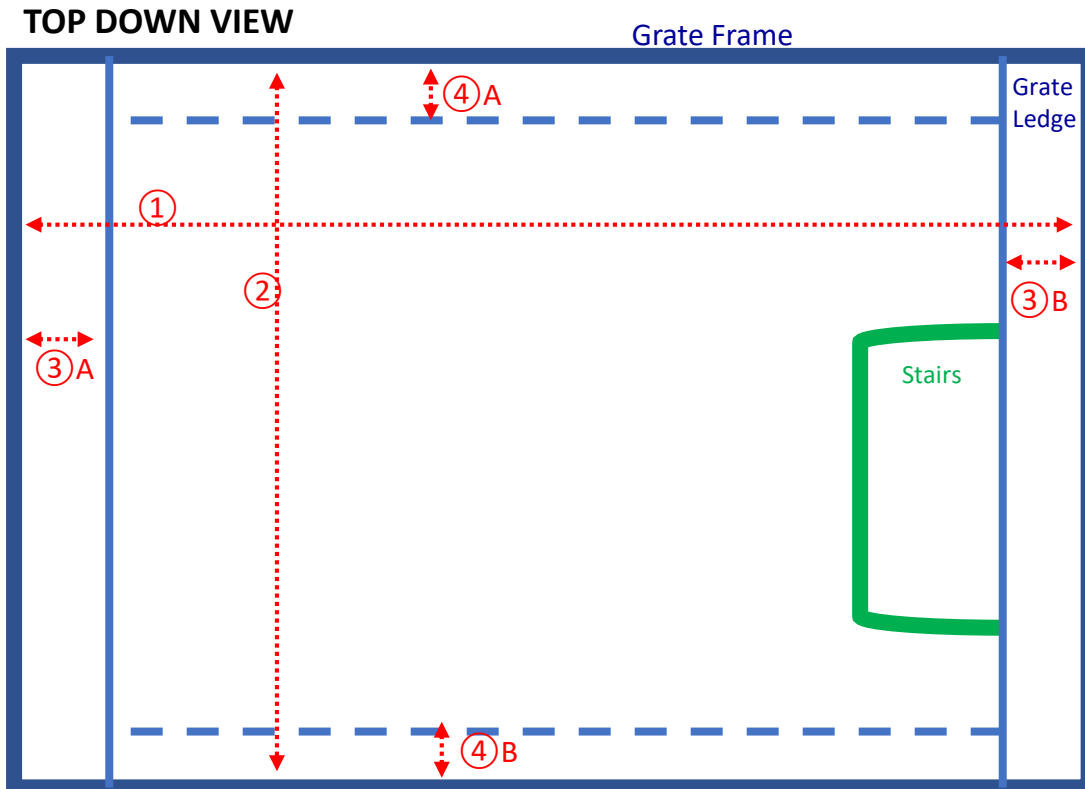

1) Length _____" (inches)

2) Width _____"

3) End Ledge (A) _____"

(B) _____"

4) Side Ledge (A) _____"

(B) _____"

5) Depth - bottom of grate frame
 to shallowest point of inlet _____"

6) Outlet Pipe Diameter _____"

6.1 Draw location of Outlet Pipe on Top Down View.

Stairs. Are there stairs? YES NO If Yes,

7.A) Bottom of grate to top of step _____"

7.B) Step extended from wall _____"

7.1 Draw location of Stairs on Top Down View.

IRREGULARITIES (If yes, explain & photo):

A) Is grate frame or ledge warped or non-rectangular?

B) Is there an Inlet Pipe?

C) Are there any obstructions in the inlet?

D) Is the grate irregular or have cut-outs?

E) Anything else irregular?

Photos Needed Showing: 1) Inlet & Surroundings, 2) Top Down with grate ledges, discharge pipe, stairs, 3) All irregularities

TOP DOWN VIEW

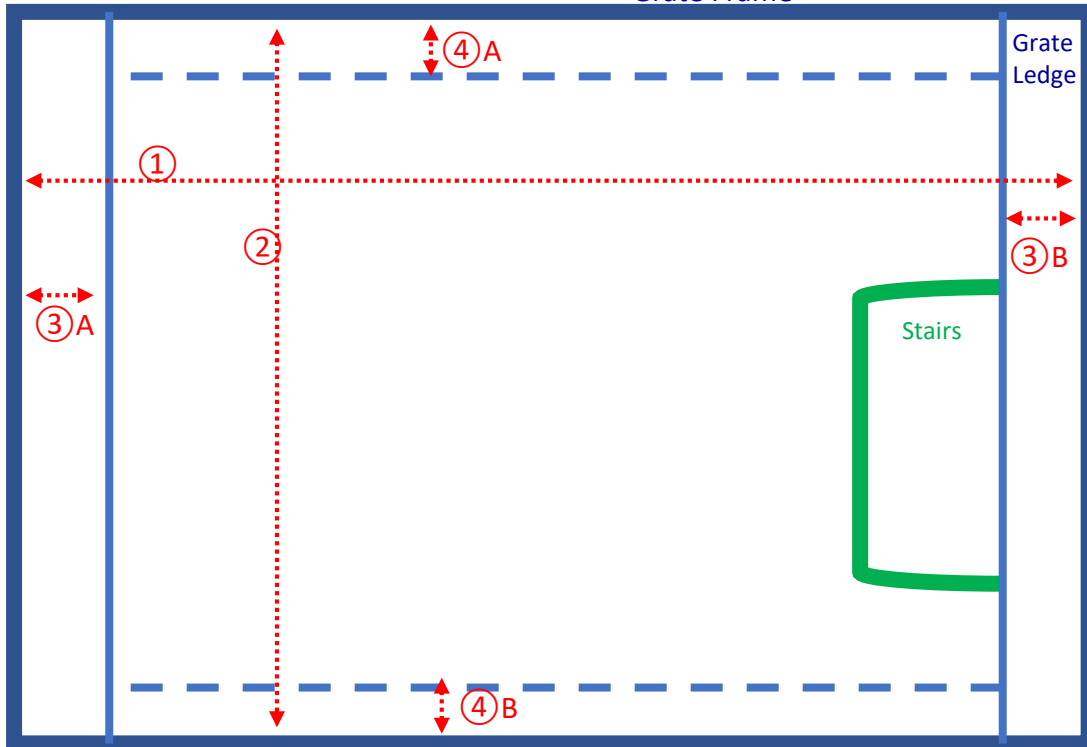

SIDE VIEW

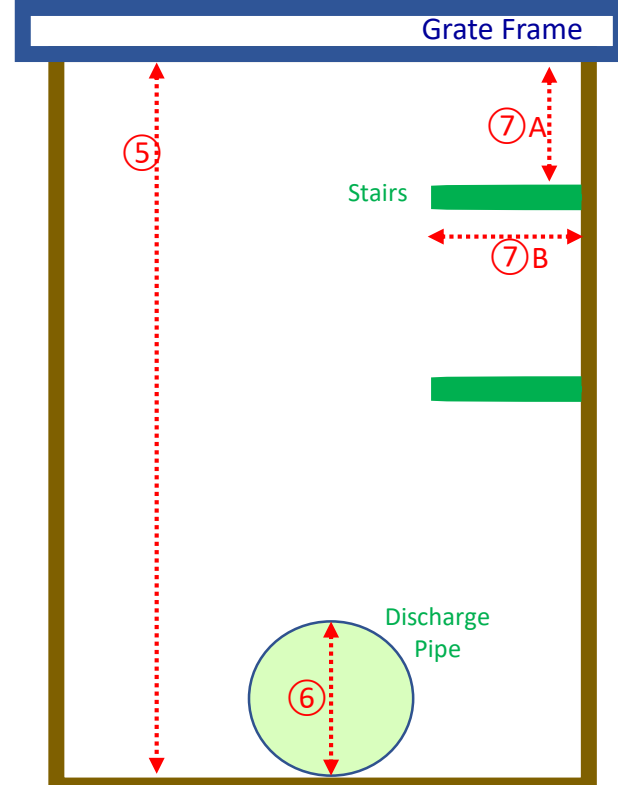

1) Length _____" (inches)

2) Width _____"

3) End Ledge (A) _____"

(B) _____"

4) Side Ledge (A) _____"

(B) _____"

5) Depth - bottom of grate frame
 to shallowest point of inlet _____"

6) Outlet Pipe Diameter _____"

6.1 Draw location of Outlet Pipe on Top Down View.

Stairs. Are there stairs? YES NO If Yes,

7.A) Bottom of grate to top of step _____"

7.B) Step extended from wall _____"

7.1 Draw location of Stairs on Top Down View.

IRREGULARITIES (If yes, explain & photo):

A) Is grate frame or ledge warped or non-rectangular?

B) Is there an Inlet Pipe?

C) Are there any obstructions in the inlet?

D) Is the grate irregular or have cut-outs?

E) Anything else irregular?

Photos Needed Showing: 1) Inlet & Surroundings, 2) Top Down with grate ledges, discharge pipe, stairs, 3) All irregularities

TOP DOWN VIEW

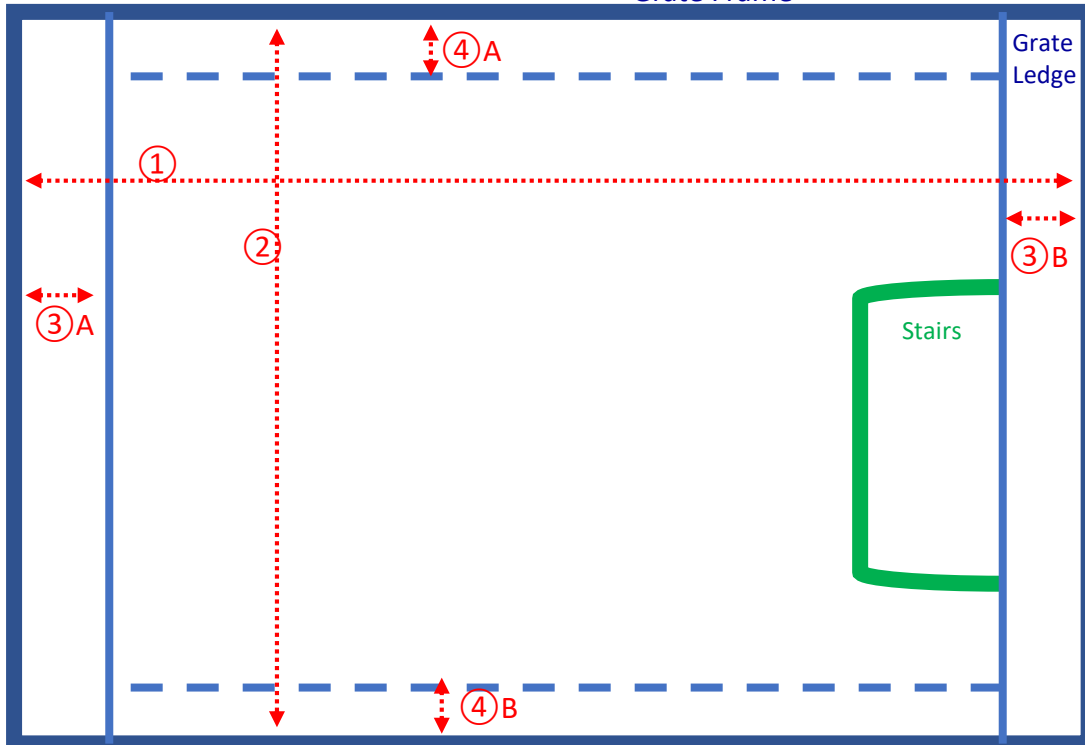

SIDE VIEW

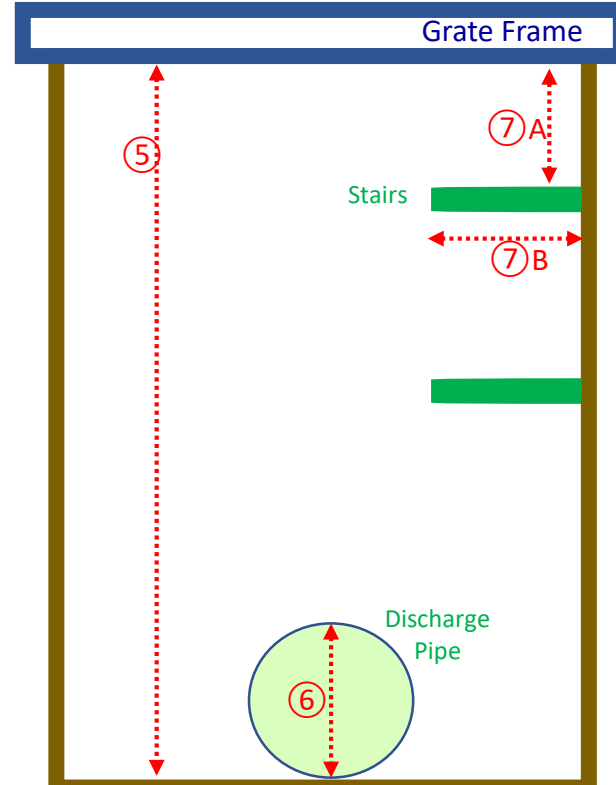

- 1) Length _____" (inches)
- 2) Width _____"
- 3) End Ledge (A) _____"
(B) _____"
- 4) Side Ledge (A) _____"
(B) _____"
- 5) Depth - bottom of grate frame
to shallowest point of inlet _____"
- 6) Outlet Pipe Diameter _____"
- 6.1 Draw location of Outlet Pipe on Top Down View.
- Stairs. Are there stairs? YES NO If Yes,
- 7.A) Bottom of grate to top of step _____"
- 7.B) Step extended from wall _____"
- 7.1 Draw location of Stairs on Top Down View.

- IRREGULARITIES** (If yes, explain & photo):
- A) Is grate frame or ledge warped or non-rectangular?
 - B) Is there an Inlet Pipe?
 - C) Are there any obstructions in the inlet?
 - D) Is the grate irregular or have cut-outs?
 - E) Anything else irregular?

Photos Needed Showing: 1) Inlet & Surroundings, 2) Top Down with grate ledges, discharge pipe, stairs, 3) All irregularities

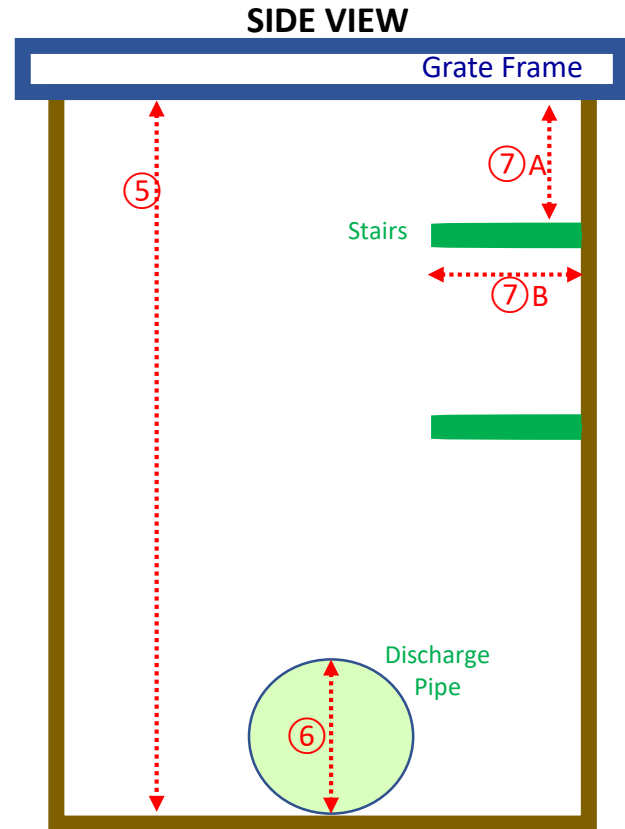
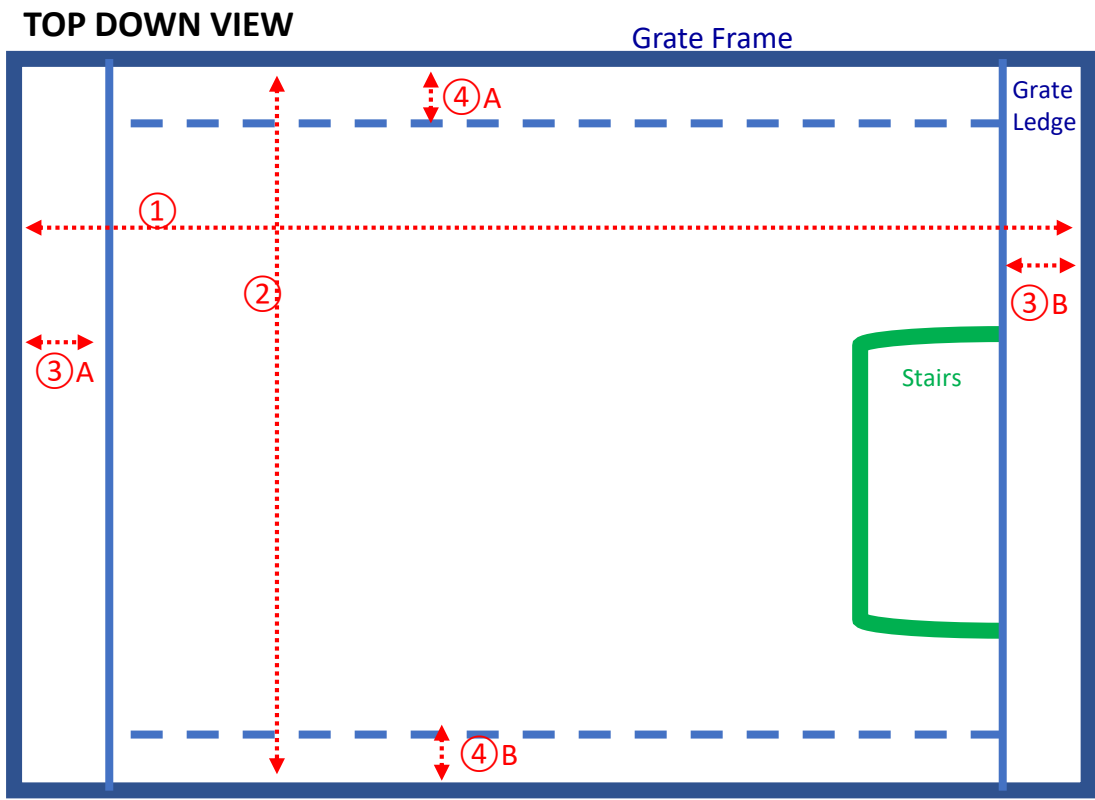

1) Length _____" (inches)

2) Width _____"

3) End Ledge (A) _____"

(B) _____"

4) Side Ledge (A) _____"

(B) _____"

5) Depth - bottom of grate frame
 to shallowest point of inlet _____"

6) Outlet Pipe Diameter _____"

6.1 Draw location of Outlet Pipe on Top Down View.

Stairs. Are there stairs? YES NO If Yes,

7.A) Bottom of grate to top of step _____"

7.B) Step extended from wall _____"

7.1 Draw location of Stairs on Top Down View.

IRREGULARITIES (If yes, explain & photo):

A) Is grate frame or ledge warped or non-rectangular?

B) Is there an Inlet Pipe?

C) Are there any obstructions in the inlet?

D) Is the grate irregular or have cut-outs?

E) Anything else irregular?

Photos Needed Showing: 1) Inlet & Surroundings, 2) Top Down with grate ledges, discharge pipe, stairs, 3) All irregularities

TOP DOWN VIEW

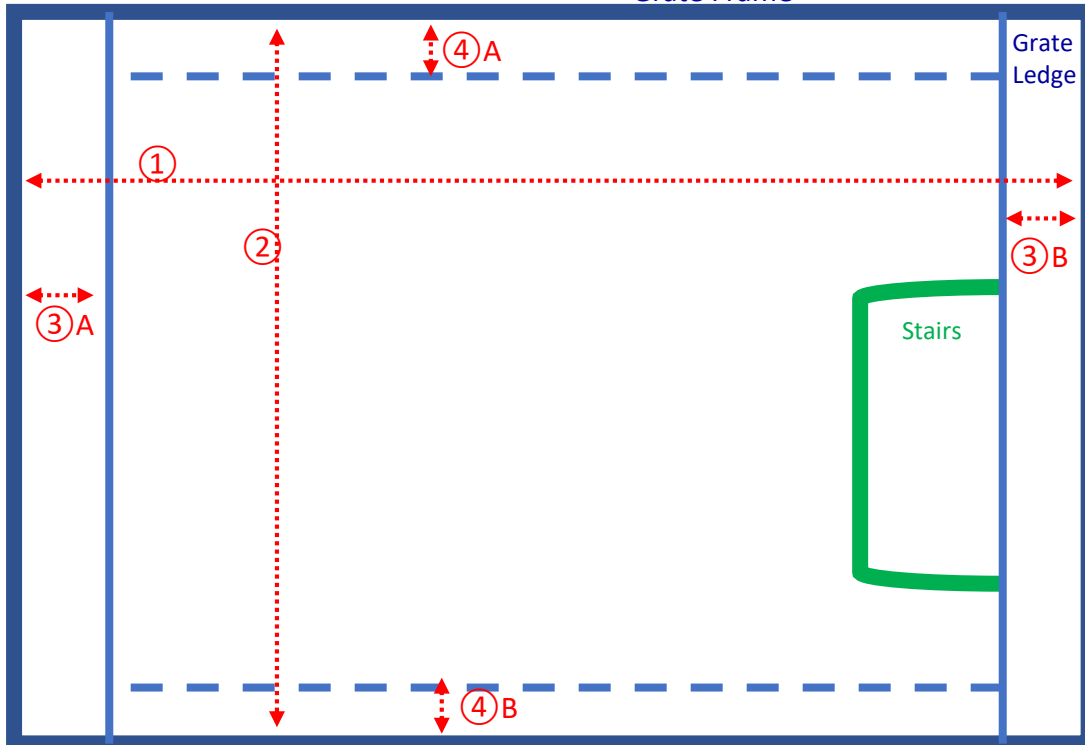

SIDE VIEW

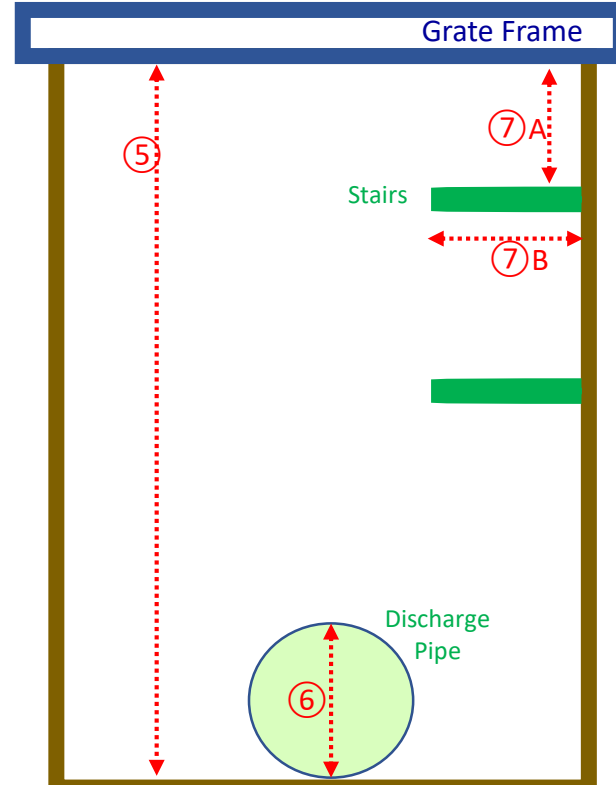

1) Length _____" (inches)

2) Width _____"

3) End Ledge (A) _____"

(B) _____"

4) Side Ledge (A) _____"

(B) _____"

5) Depth - bottom of grate frame
 to shallowest point of inlet _____"

6) Outlet Pipe Diameter _____"

6.1 Draw location of Outlet Pipe on Top Down View.

Stairs. Are there stairs? YES NO If Yes,

7.A) Bottom of grate to top of step _____"

7.B) Step extended from wall _____"

7.1 Draw location of Stairs on Top Down View.

IRREGULARITIES (If yes, explain & photo):

A) Is grate frame or ledge warped or non-rectangular?

B) Is there an Inlet Pipe?

C) Are there any obstructions in the inlet?

D) Is the grate irregular or have cut-outs?

E) Anything else irregular?

Photos Needed Showing: 1) Inlet & Surroundings, 2) Top Down with grate ledges, discharge pipe, stairs, 3) All irregularities

TOP DOWN VIEW

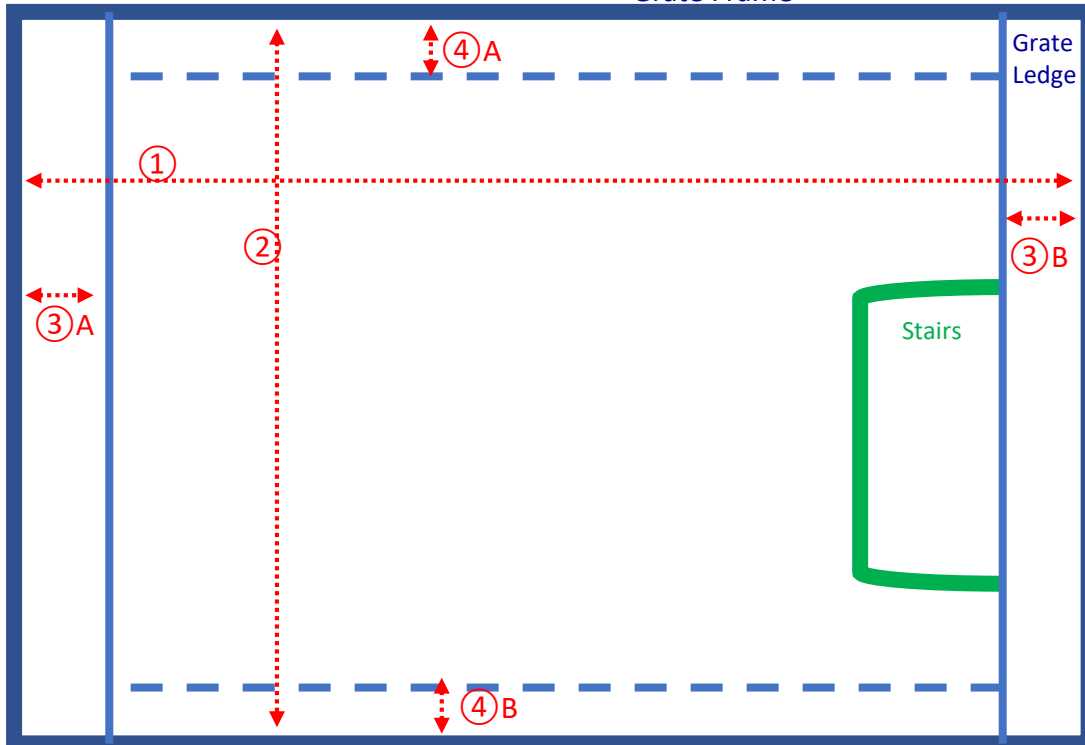

SIDE VIEW

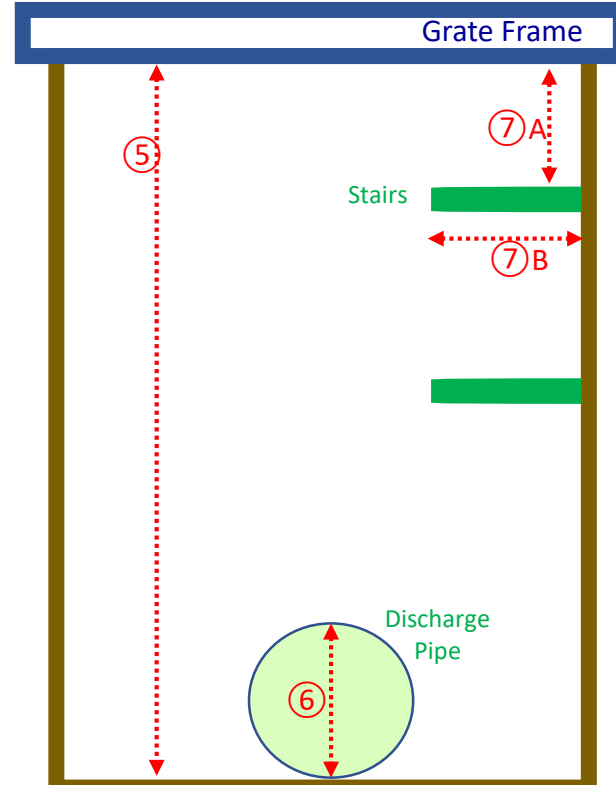

1) Length _____" (inches)

2) Width _____"

3) End Ledge (A) _____"

(B) _____"

4) Side Ledge (A) _____"

(B) _____"

5) Depth - bottom of grate frame
 to shallowest point of inlet _____"

6) Outlet Pipe Diameter _____"

6.1 Draw location of Outlet Pipe on Top Down View.

Stairs. Are there stairs? YES NO If Yes,

7.A) Bottom of grate to top of step _____"

7.B) Step extended from wall _____"

7.1 Draw location of Stairs on Top Down View.

IRREGULARITIES (If yes, explain & photo):

A) Is grate frame or ledge warped or non-rectangular?

B) Is there an Inlet Pipe?

C) Are there any obstructions in the inlet?

D) Is the grate irregular or have cut-outs?

E) Anything else irregular?

Photos Needed Showing: 1) Inlet & Surroundings, 2) Top Down with grate ledges, discharge pipe, stairs, 3) All irregularities

TOP DOWN VIEW

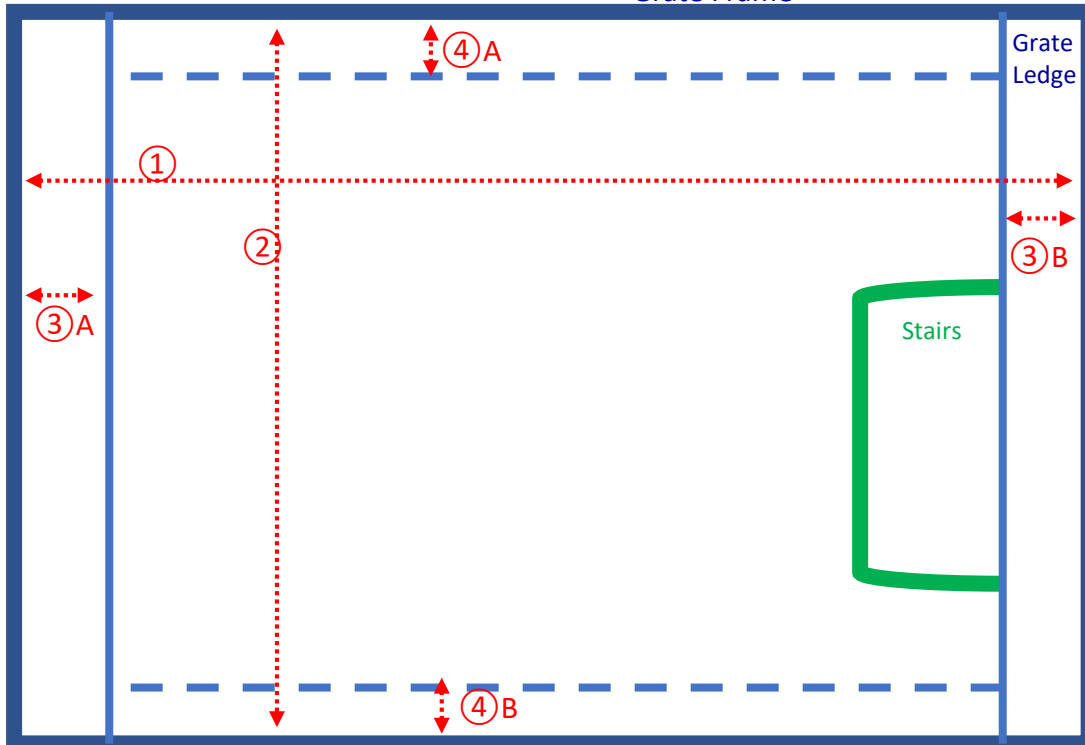

SIDE VIEW

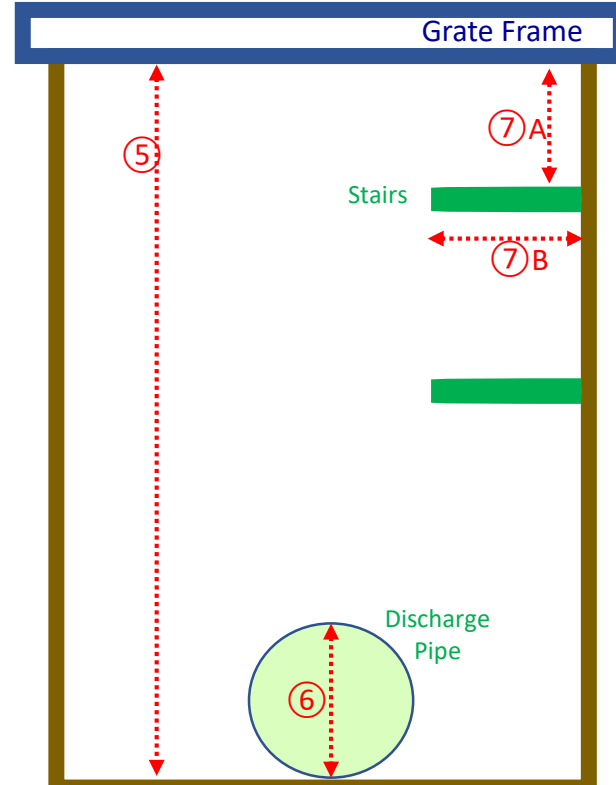

- 1) Length _____" (inches)
- 2) Width _____"
- 3) End Ledge (A) _____"
(B) _____"
- 4) Side Ledge (A) _____"
(B) _____"
- 5) Depth - bottom of grate frame
to shallowest point of inlet _____"
- 6) Outlet Pipe Diameter _____"
- 6.1 Draw location of Outlet Pipe on Top Down View.
- Stairs. Are there stairs? YES NO If Yes,
- 7.A) Bottom of grate to top of step _____"
- 7.B) Step extended from wall _____"
- 7.1 Draw location of Stairs on Top Down View.

- IRREGULARITIES** (If yes, explain & photo):
- A) Is grate frame or ledge warped or non-rectangular?
 - B) Is there an Inlet Pipe?
 - C) Are there any obstructions in the inlet?
 - D) Is the grate irregular or have cut-outs?
 - E) Anything else irregular?

Photos Needed Showing: 1) Inlet & Surroundings, 2) Top Down with grate ledges, discharge pipe, stairs, 3) All irregularities

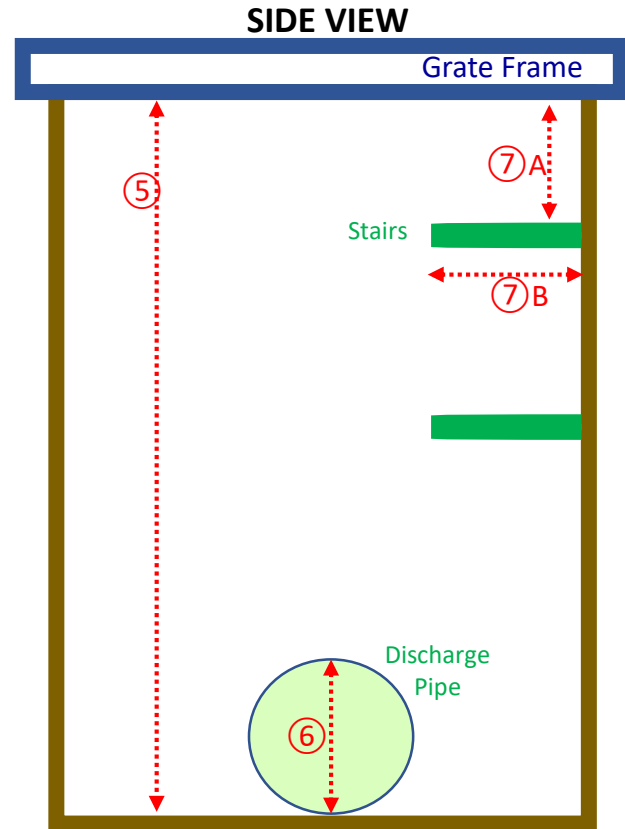
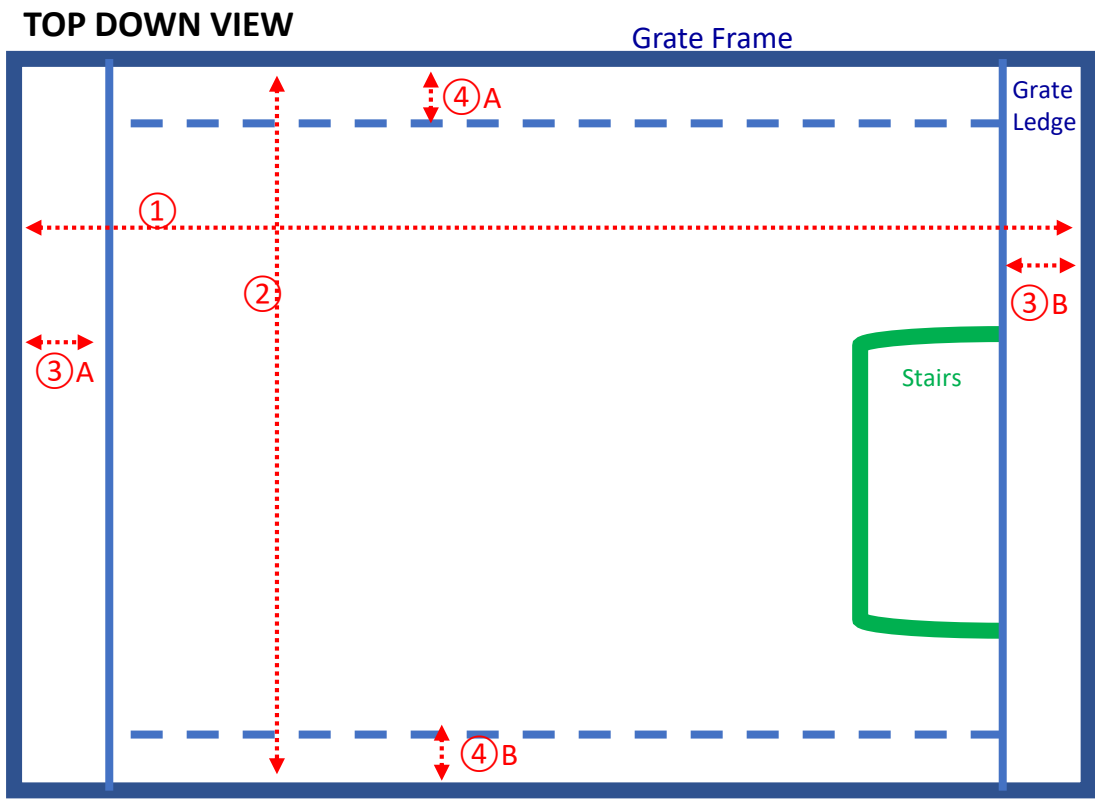

1) Length _____" (inches)

2) Width _____"

3) End Ledge (A) _____"

(B) _____"

4) Side Ledge (A) _____"

(B) _____"

5) Depth - bottom of grate frame
 to shallowest point of inlet _____"

6) Outlet Pipe Diameter _____"

6.1 Draw location of Outlet Pipe on Top Down View.

Stairs. Are there stairs? YES NO If Yes,

7.A) Bottom of grate to top of step _____"

7.B) Step extended from wall _____"

7.1 Draw location of Stairs on Top Down View.

IRREGULARITIES (If yes, explain & photo):

A) Is grate frame or ledge warped or non-rectangular?

B) Is there an Inlet Pipe?

C) Are there any obstructions in the inlet?

D) Is the grate irregular or have cut-outs?

E) Anything else irregular?

Photos Needed Showing: 1) Inlet & Surroundings, 2) Top Down with grate ledges, discharge pipe, stairs, 3) All irregularities

TOP DOWN VIEW

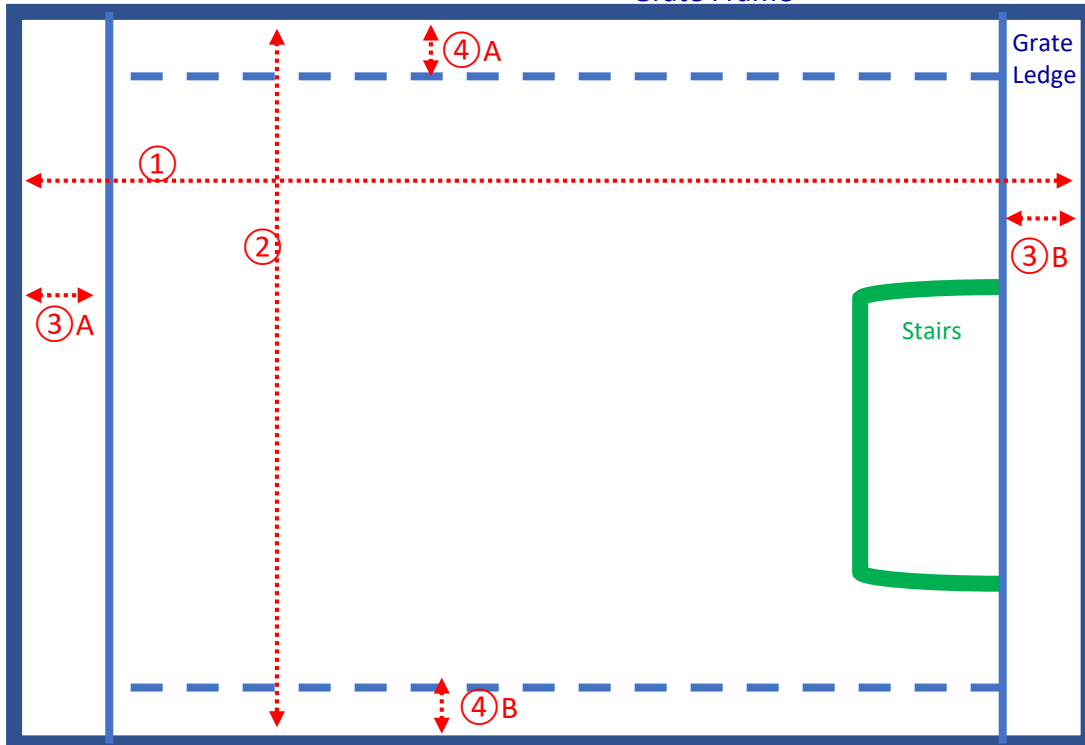

SIDE VIEW

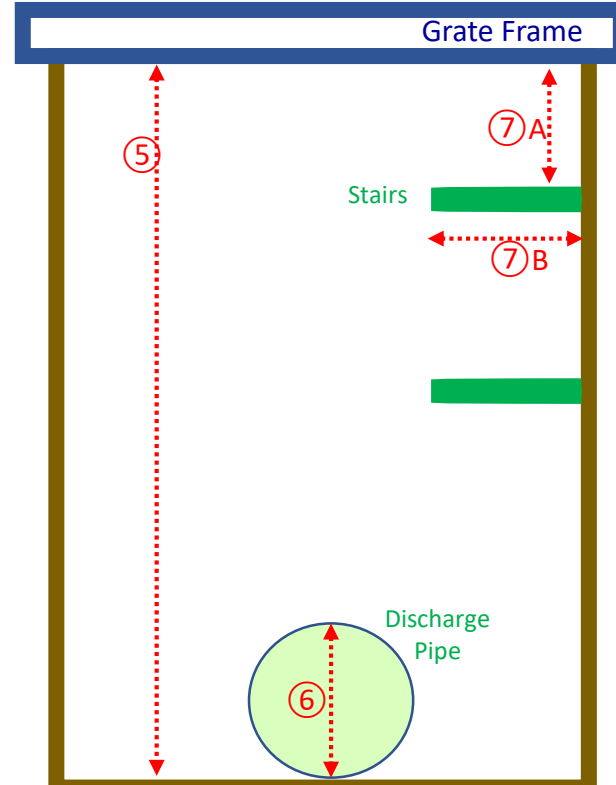

1) Length _____" (inches)

2) Width _____"

3) End Ledge (A) _____"

(B) _____"

4) Side Ledge (A) _____"

(B) _____"

5) Depth - bottom of grate frame
 to shallowest point of inlet _____"

6) Outlet Pipe Diameter _____"

6.1 Draw location of Outlet Pipe on Top Down View.

Stairs. Are there stairs? YES NO If Yes,

7.A) Bottom of grate to top of step _____"

7.B) Step extended from wall _____"

7.1 Draw location of Stairs on Top Down View.

IRREGULARITIES (If yes, explain & photo):

A) Is grate frame or ledge warped or non-rectangular?

B) Is there an Inlet Pipe?

C) Are there any obstructions in the inlet?

D) Is the grate irregular or have cut-outs?

E) Anything else irregular?

Photos Needed Showing: 1) Inlet & Surroundings, 2) Top Down with grate ledges, discharge pipe, stairs, 3) All irregularities

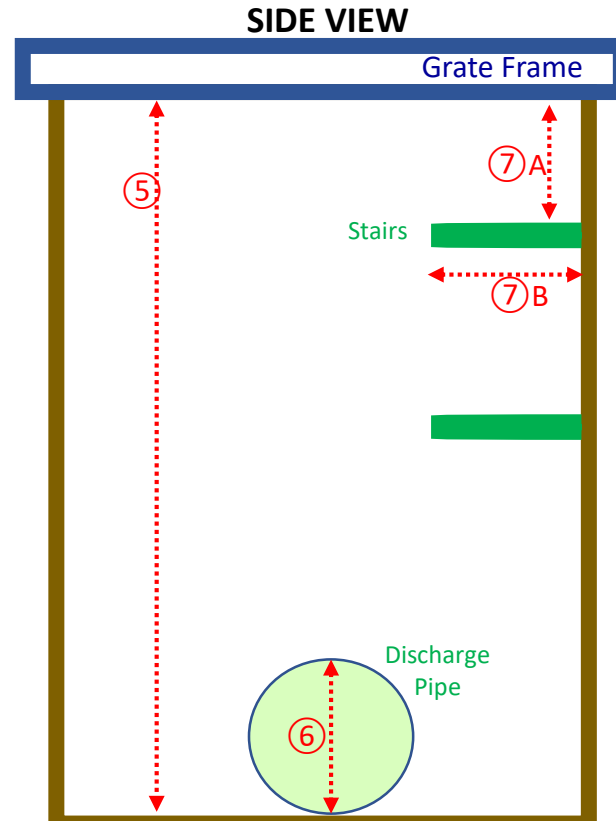
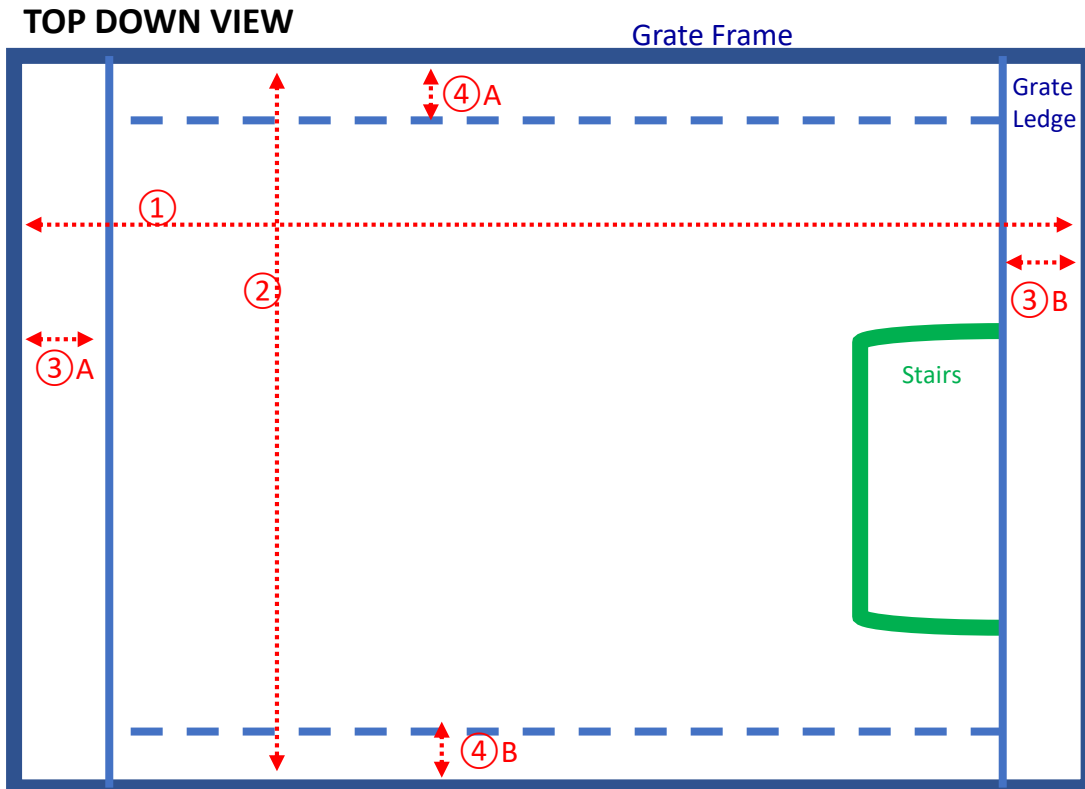

Appendix C: Monitoring Field Form

Complete Prior to Inspection



Site ID: _____

Inspection Month/Year: _____

Evaluation of Vegetation Effect on Discharge of Trash Contract 43A0379, Task Order #14 Field Form						
SITE INFORMATION						
Site ID (Name):						
Caltrans District (#):	County:	Route:	RWQCB (#):	Lat/Long:		
MAINTENANCE INFORMATION:						
Caltrans Maintenance Supervisor contacted: <input type="checkbox"/> Yes <input type="checkbox"/> No						
Maintenance Supervisor Name:			Maintenance Contact #:			
Date of last Maintenance:						
Notes from Maintenance Supervisor:						
• • •						
Removal of Trash						
<input type="checkbox"/> Caltrans		<input type="checkbox"/> Adopt-a-Highway Program		<input type="checkbox"/> Special Crews (Parolee/Veterans)		
<input type="checkbox"/> Other _____						
STORM EVENT DATA						
Weather Data Recorded: <input type="checkbox"/> Yes <input type="checkbox"/> No			Reporting Month:			
Number of Storm Events (Actual):			Number of Storm Events (Average):			
Monthly Precipitation (Actual):			Monthly Precipitation (Average):			
	Start Date/Time (mm/dd-hh:mm)	End Date/Time (mm/dd-hh:mm)	Precipitation (inches)	Max Intensity 1, 3 and 6 hour (inches/hour)	Storm Frequency Depth Intensity (XXXX Year Event)	
1						
2						
3						
4						
5						
6						
7						
8						
9						
Raw monthly data included at the end of each report (site specific data)						
1. NOAA Atlas 14: https://hdsc.nws.noaa.gov/hdsc/pfds/pfds_map_cont.html?blkcrk=ca						
2. Weather Records: https://www.wrh.noaa.gov/mesovest/timeseries.php?sid=KCNO&mun=168&vfo=sax						
INSPECTION INFORMATION						
Inspection Date:		Time in:		Time out:		
Consultant:						
Team Leader Name:			Additional Personnel Present:			

Complete at Site



Site ID: _____
 Inspection Month/Year: _____

Evaluation of Vegetation Effect on Discharge of Trash <i>Contract #11A0379, Task Order #14</i> Field Form									
VEGETATION OBSERVATIONS									
<p><u>Vegetation Type (check all that apply):</u></p> <table style="width: 100%; border: none;"> <tr> <td style="width: 25%;"><input type="checkbox"/> Trees and shrubs</td> <td style="width: 25%;"><input type="checkbox"/> Wildflowers</td> <td style="width: 25%;"><input type="checkbox"/> Meadow Mixtures</td> <td style="width: 25%;"><input type="checkbox"/> Grasses</td> </tr> <tr> <td><input type="checkbox"/> Annuals</td> <td><input type="checkbox"/> Perennials</td> <td><input type="checkbox"/> Bulbs</td> <td><input type="checkbox"/> Combination of plants</td> </tr> </table> <p>Was Vegetation Recently Maintained: <input type="checkbox"/> Yes <input type="checkbox"/> No <input type="checkbox"/> Unknown</p> <p>Vegetation height: _____ inches</p> <p>Percent vegetative cover: _____ %</p> <p>Is observed vegetative cover dormant (brown): <input type="checkbox"/> Yes <input type="checkbox"/> No</p> <p>Percent of vegetation gone dormant (% of active): _____ %</p> <p><u>Additional Vegetation Observations:</u></p> <hr/> <hr/> <hr/> <hr/> <hr/> <hr/>		<input type="checkbox"/> Trees and shrubs	<input type="checkbox"/> Wildflowers	<input type="checkbox"/> Meadow Mixtures	<input type="checkbox"/> Grasses	<input type="checkbox"/> Annuals	<input type="checkbox"/> Perennials	<input type="checkbox"/> Bulbs	<input type="checkbox"/> Combination of plants
<input type="checkbox"/> Trees and shrubs	<input type="checkbox"/> Wildflowers	<input type="checkbox"/> Meadow Mixtures	<input type="checkbox"/> Grasses						
<input type="checkbox"/> Annuals	<input type="checkbox"/> Perennials	<input type="checkbox"/> Bulbs	<input type="checkbox"/> Combination of plants						
DISCHARGE OBSERVATIONS									
<p><u>Conditions (check all that apply):</u></p> <ul style="list-style-type: none"> <input type="checkbox"/> Water Pounding at capture device <ul style="list-style-type: none"> Is ponding water a safety hazard (hydroplaning): <input type="checkbox"/> Yes <input type="checkbox"/> No <input type="checkbox"/> Evidence of flow bypassing capture device <input type="checkbox"/> Trash captured by inlet grate cover <input type="checkbox"/> Trash captured by catch basin insert <input type="checkbox"/> Dislodged vegetation captured by inlet grate cover <input type="checkbox"/> Dislodged vegetation captured by catch basin insert <input type="checkbox"/> Vegetative strip degradation <ul style="list-style-type: none"> <input type="checkbox"/> From concentrated storm water <input type="checkbox"/> From another source (vehicles, etc.): _____ <p><u>Other Discharge Observations:</u></p> <hr/> <hr/> <hr/> <hr/>									

Complete at Site



Site ID: _____
 Inspection Month/Year: _____

Evaluation of Vegetation Effect on Discharge of Trash <i>Contract 4340379, Task Order #14</i> Field Form			
TRASH			
<u>Measurement Method (check all that apply):</u>			
<input type="checkbox"/> Plastic Bucket	<input type="checkbox"/> Trash Bags	<input type="checkbox"/> Other _____	
<input type="checkbox"/> Standard Five (5) Gallon	<input type="checkbox"/> Size _____ Gallons		
<input type="checkbox"/> Other _____			
<u>Quantitative Observations:</u>			
At Inlet Grate:	Trash volume: _____	gallon(s)	
In Catch Basin Insert:	Trash volume: _____	gallon(s)	
Trash Observed in Vegetative Strip:	<input type="checkbox"/> Yes	<input type="checkbox"/> No	
Trash Observed in Dike (if Applicable):	<input type="checkbox"/> Yes	<input type="checkbox"/> No	
Trash Observed at Inlet Grate:	<input type="checkbox"/> Yes	<input type="checkbox"/> No	
Trash Observed in Catch Basin Insert:	<input type="checkbox"/> Yes	<input type="checkbox"/> No	
<u>Categories and Percentages</u>			
Cardboard/Chipboard	_____ %	Paper	_____ %
Cigarette Butts	_____ %	Plastic – Film	_____ %
Cloth	_____ %	Plastic – Moldable	_____ %
Glass	_____ %	Styrofoam	_____ %
Metal (Foil and Molded)	_____ %	Wood	_____ %
Other _____	_____ %		
<u>Qualitative Observations:</u>			
Record the type of trash, location(s), area(s) covered, and depth(s), as applicable.			
In strip:	_____		

In dike:	_____		

At grate:	_____		

In insert:	_____		

Other Trash Observations:	_____		

PLEASE ATTACH PHOTOS AT THE END OF THIS REPORT			
(Team Leader's Signature)			

Appendix D: Data Summaries

Data Summary – Site 1

Site ID (Name): 1				
Caltrans District: 4	County: Contra Costa	Route/PM: SR-4 / R5.639	RWQCB (#): 2	Lat/Long: 38.010, -122.171

	Month/Year	Trash Discharge (gal)	Trash Generation Rate (gal/ac/yr)	Rainfall (in)	% Vegetative Cover	Month Maintenance Performed
Year 1	Feb-20	0.1		0	95	0
	Mar-20	-		1.7	95	0
	Apr-20	-		0.11	95	0
	May-20	0.01		0.26	95	0
	Jun-20	0.3		0	95	0
	Jul-20	0.03		0	95	0
	Aug-20	0		0	95	0
	Sep-20	0		0	95	1
	Oct-20	0		0	95	0
	Nov-20	0		0.3	95	0
	Dec-20	0		0.95	85	0
	Jan-21	0.03		1.12	85	0
	Totals	0.47	0.26	4.44	N/A	1
Year 2	Feb-21	0		0.44	85	0
	Mar-21	0		0.84	70	0
	Apr-21	0		0	70	0
	May-21	0		0	85	1
	Jun-21	0		0	95	0
	Jul-21	0		0	95	0
	Aug-21	0		0	95	0
	Sep-21	0		0	95	0
	Oct-21	0		1.31	90	0
	Nov-21	0.02		0.69	85	0
	Dec-21	0.02		4.55	85	0
	Jan-22	0.02		0	90	0
	Totals	0.06	0.03	7.83	N/A	1

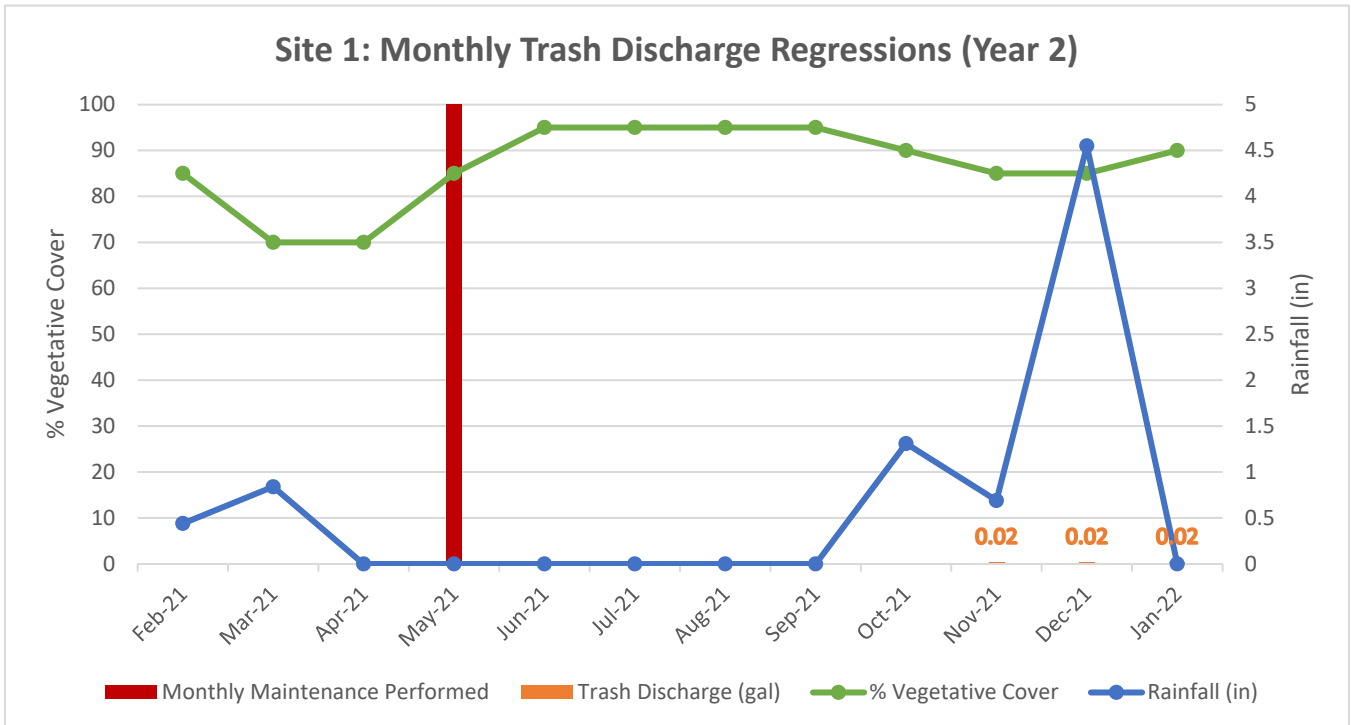
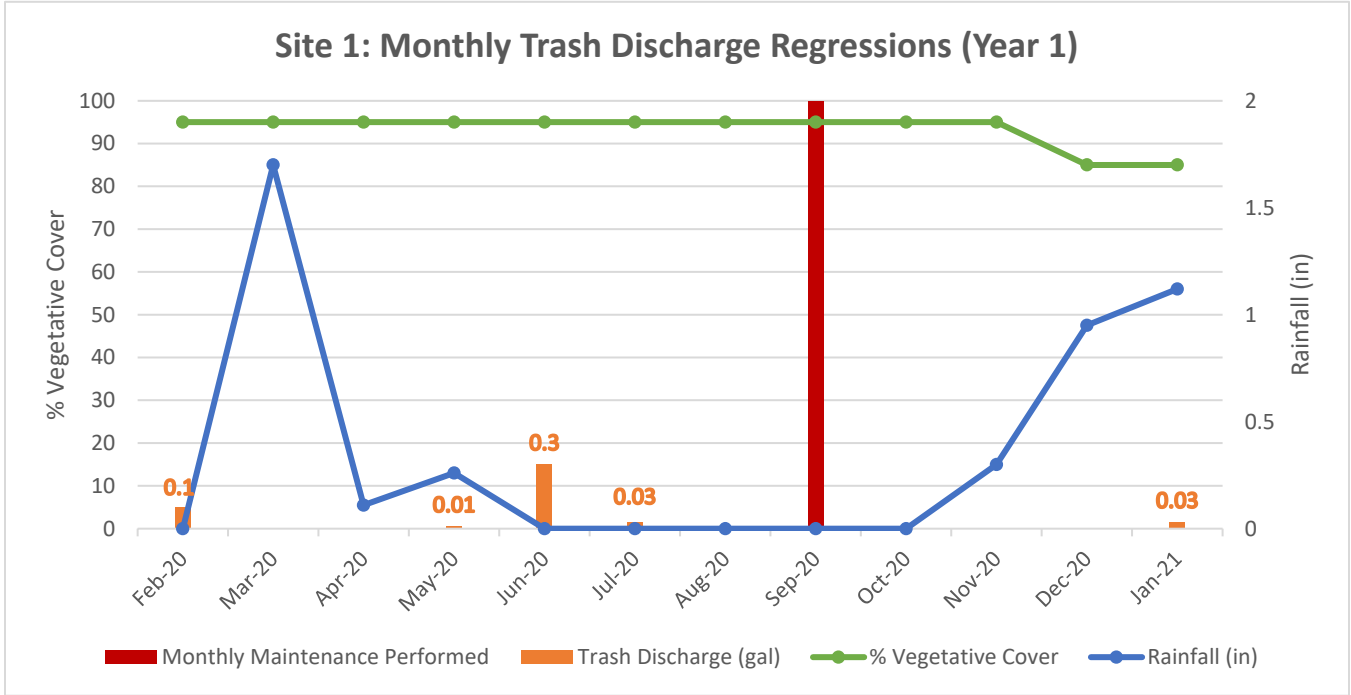

Data Summary – Site 2

Site ID (Name): 2				
Caltrans District: 4	County: Martinez	Route/PM: SR-4 / R7.464	RWQCB (#): 2	Lat/Long: 37.996, -122.145

	Month/Year	Trash Discharge (gal)	Trash Generation Rate (gal/ac/yr)	Rainfall (in)	% Vegetative Cover	Month Maintenance Performed
Year 1	Feb-20	0		0	80	0
	Mar-20			1.7	80	0
	Apr-20			0.11	80	0
	May-20	0.4		0.26	80	0
	Jun-20	0.11		0	80	0
	Jul-20	0.01		0	80	0
	Aug-20	0		0	80	0
	Sep-20	0.01		0	80	0
	Oct-20	0		0	80	0
	Nov-20	0.2		0.3	85	1
	Dec-20	0.1		0.95	90	0
	Jan-21	0.1		1.12	85	0
	Totals	0.93	0.28	4.44	N/A	1
Year 2	Feb-21	0		0.44	80	1
	Mar-21	0		0.84	80	0
	Apr-21	0		0	85	1
	May-21	0		0	75	1
	Jun-21	0		0	75	0
	Jul-21	0		0	80	0
	Aug-21	0		0	80	0
	Sep-21	0		0	80	0
	Oct-21	0		1.31	80	0
	Nov-21	0.3		0.69	90	0
	Dec-21	0.15		4.55	90	0
	Jan-22	0.07		0	90	0
	Totals	0.52	0.15	7.83	N/A	3

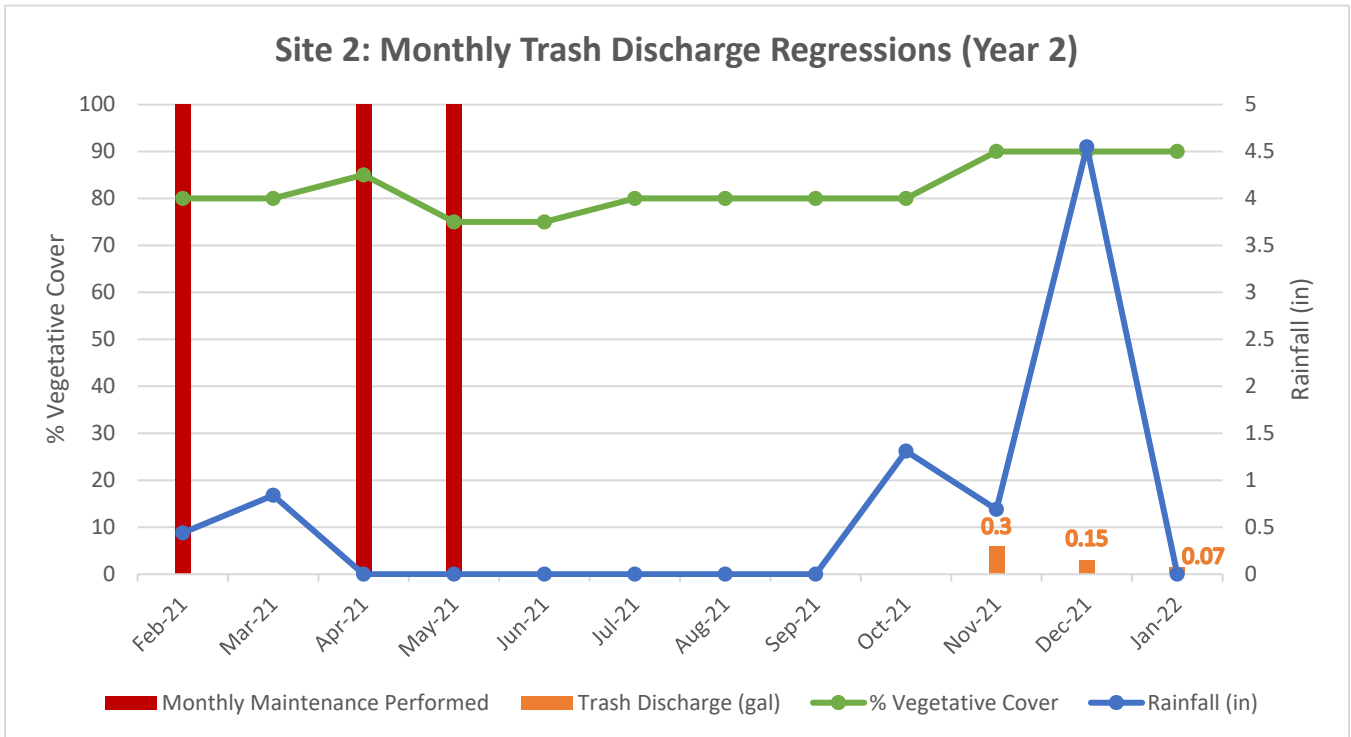
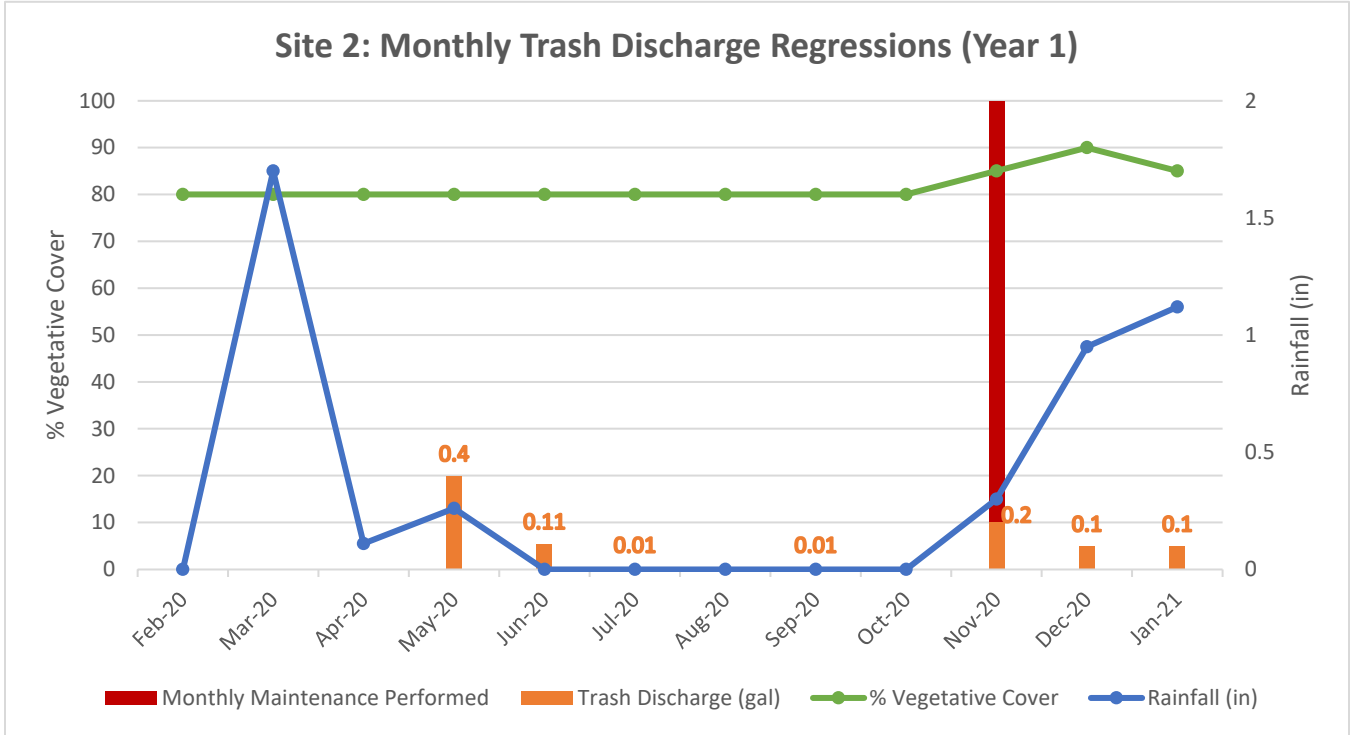

Data Summary – Site 3

Site ID (Name): 3				
Caltrans District: 4	County: Alameda	Route/PM: US-101 / 13.561	RWQCB (#): 2	Lat/Long: 38.005, -122.540

	Month/Year	Trash Discharge (gal)	Trash Generation Rate (gal/ac/yr)	Rainfall (in)	% Vegetative Cover	Month Maintenance Performed
Year 1	Feb-20	0		0	60	0
	Mar-20			1.51	60	0
	Apr-20			0.91	70	0
	May-20	1		0.44	70	0
	Jun-20	0.5		0	70	0
	Jul-20	0.3		0	60	0
	Aug-20	0.5		0	60	0
	Sep-20	0.01		0	50	0
	Oct-20	0.5		0	50	0
	Nov-20	0.5		0.17	40	0
	Dec-20	0.1		1.05	40	0
	Jan-21	0.3		2.42	50	0
	Totals	3.71	3.37	6.5	N/A	0
Year 2	Feb-21	0.1		1.75	65	0
	Mar-21	0.2		1.62	65	0
	Apr-21	0		0	50	1
	May-21	0.1		0	50	1
	Jun-21	0		0	50	1
	Jul-21	0		0	50	1
	Aug-21	0		0	50	1
	Sep-21	0		0	40	0
	Oct-21	0		5.32	40	0
	Nov-21	0.25		0.89	50	0
	Dec-21	0.1		8.93	80	0
	Jan-22	0.1		0.25	90	0
	Totals	0.85	0.77	18.76	N/A	5

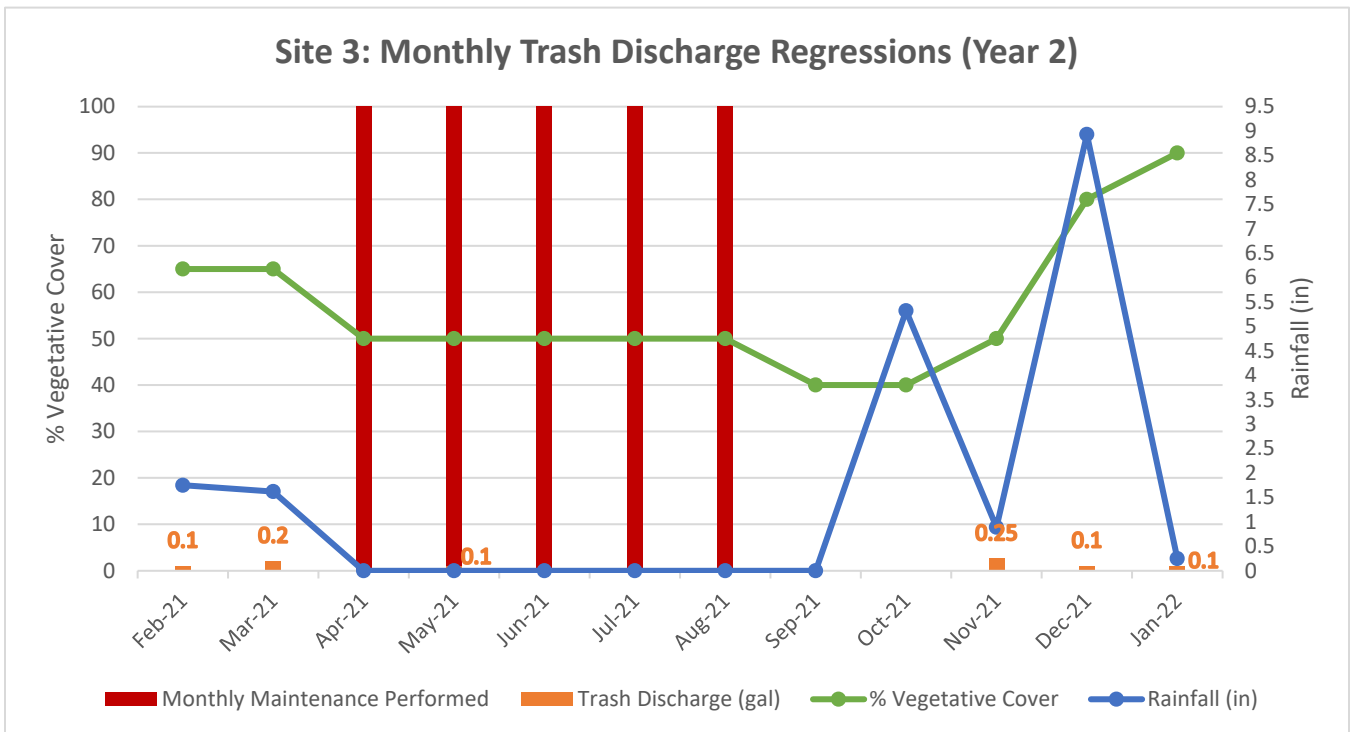
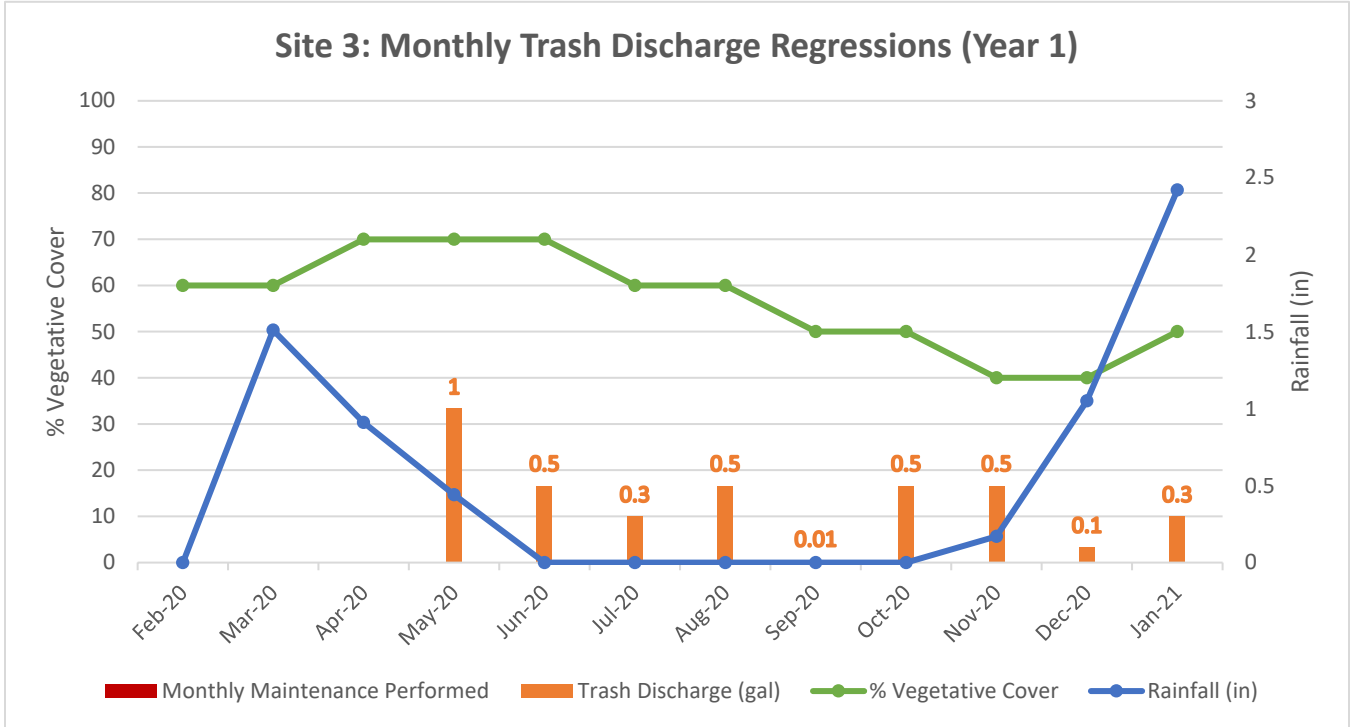

Data Summary – Site 4

Site ID (Name): 4				
Caltrans District: 4	County: Alameda	Route/PM: I-880 / R33.033	RWQCB (#): 2	Lat/Long: 37.803, -122.300

	Month/Year	Trash Discharge (gal)	Trash Generation Rate (gal/ac/yr)	Rainfall (in)	% Vegetative Cover	Month Maintenance Performed
Year 1	Feb-20	1.6		0	50	0
	Mar-20	-		1.51	50	0
	Apr-20	-		0.91	50	0
	May-20	0.5		0.44	50	0
	Jun-20	0.04		0	50	0
	Jul-20	0.07		0	50	0
	Aug-20	0.01		0	60	0
	Sep-20	0		0	60	0
	Oct-20	0.1		0	65	0
	Nov-20	0.2		0.17	80	0
	Dec-20	0.1		1.05	90	0
	Jan-21	0.65		2.42	90	0
	Totals	3.27	1.20	6.5	N/A	0
Year 2	Feb-21	0.35		1.75	10	1
	Mar-21	0		1.62	10	0
	Apr-21	0		0	40	0
	May-21	0		0	50	0
	Jun-21	0		0	50	0
	Jul-21	0		0	80	0
	Aug-21	0		0	80	0
	Sep-21	0		0	80	0
	Oct-21	0		5.32	80	0
	Nov-21	0.5		0.89	80	0
	Dec-21	2		8.93	60	0
	Jan-22	0.11		0.25	70	0
	Totals	2.96	1.08	18.76	N/A	1

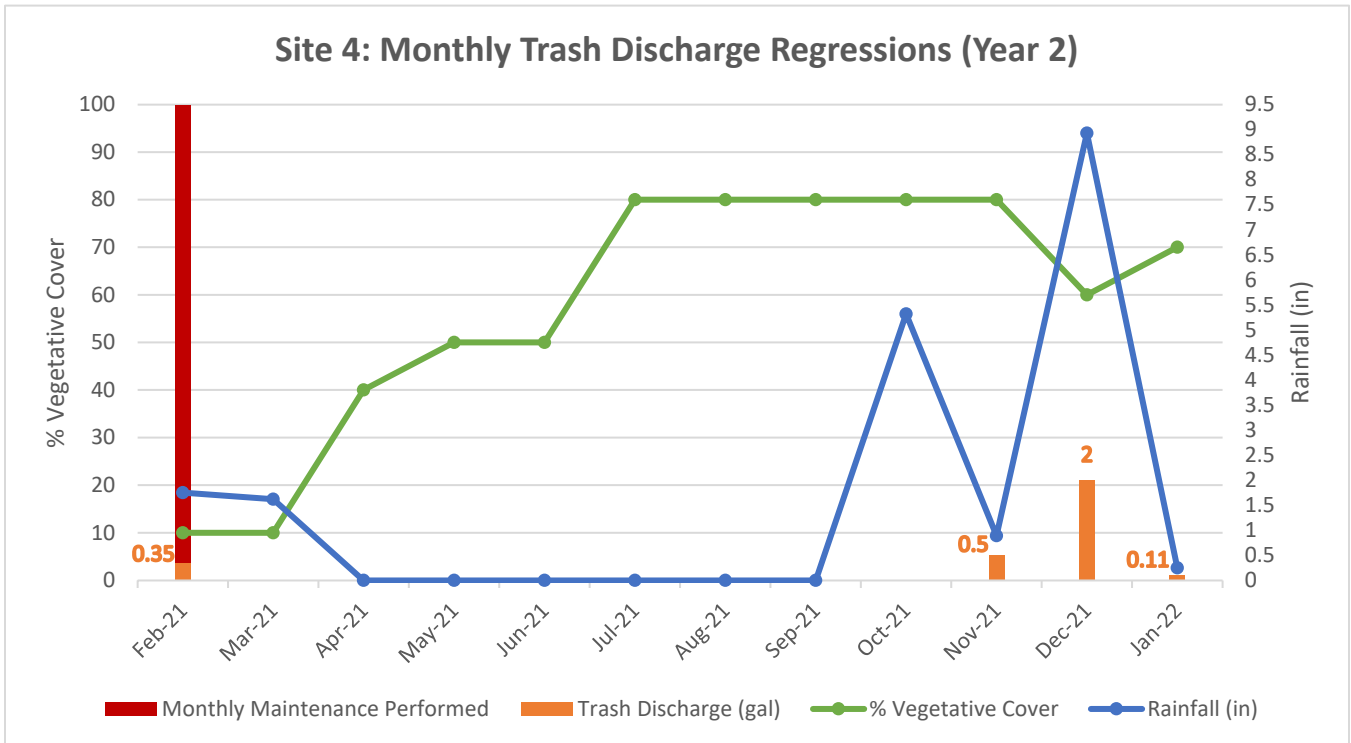
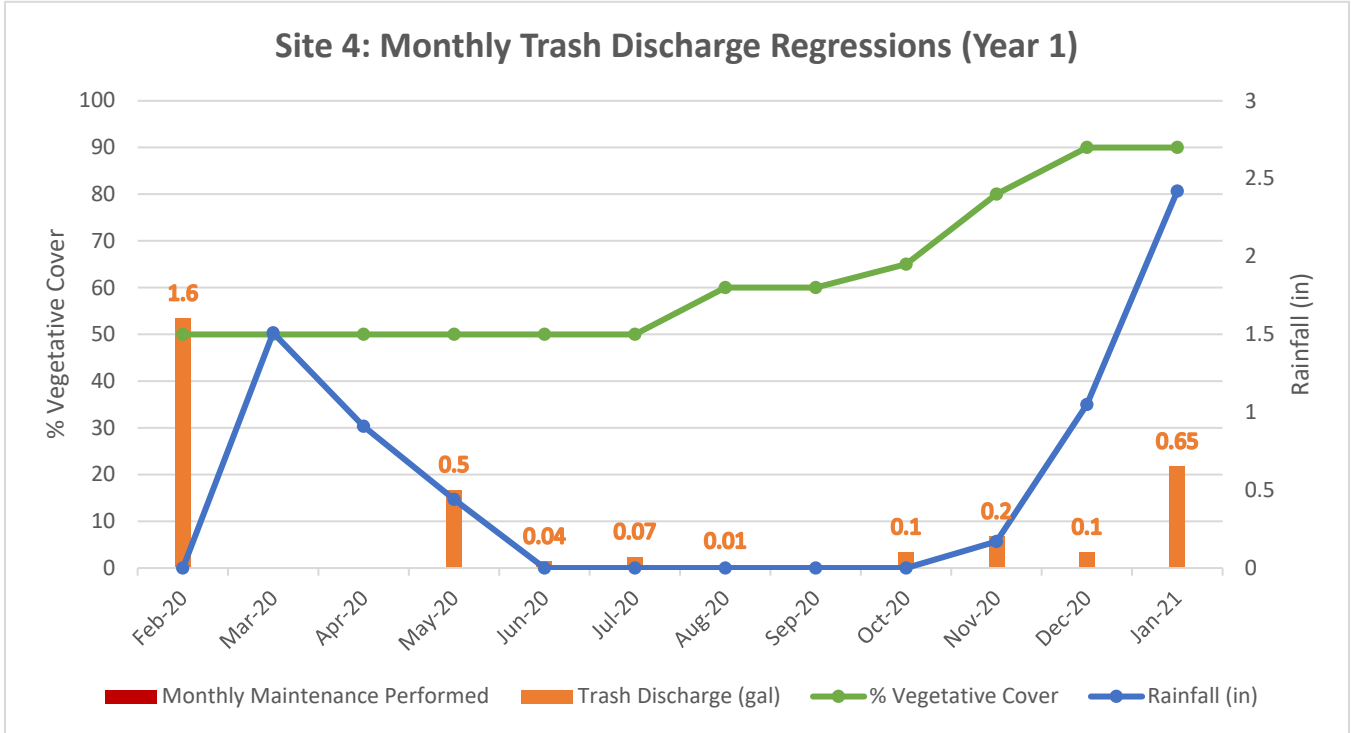

Data Summary – Site 5

Site ID (Name): 5				
Caltrans District: 3	County: Yolo	Route/PM: I-80 / 9.082	RWQCB (#): 5	Lat/Long: 38.573, -121.579

	Month/Year	Trash Discharge (gal)	Trash Generation Rate (gal/ac/yr)	Rainfall (in)	% Vegetative Cover	Month Maintenance Performed
Year 1	Feb-20	0.1		0	100	0
	Mar-20	-		1.63	100	0
	Apr-20	-		0.85	100	0
	May-20	1		0.32	100	0
	Jun-20	0.1		0	100	0
	Jul-20	0		0	90	0
	Aug-20	0		0	90	0
	Sep-20	0		0	95	0
	Oct-20	0		0	95	0
	Nov-20	0		0.13	90	0
	Dec-20	0		1.54	90	0
	Jan-21	0.05		2.5	100	0
		Totals		1.25	0.45	6.97
Year 2	Feb-21	0		0.9	100	0
	Mar-21	0		1.06	100	0
	Apr-21	0		0	100	0
	May-21	0		0	100	0
	Jun-21	0		0	100	1
	Jul-21	0		0	100	0
	Aug-21	0		0	95	0
	Sep-21	0		0.05	95	0
	Oct-21	0		6.42	95	0
	Nov-21	0.2		0.68	95	0
	Dec-21	0.01		6.98	100	0
	Jan-22	0.02		0.05	100	0
		Totals		0.23	0.08	16.14

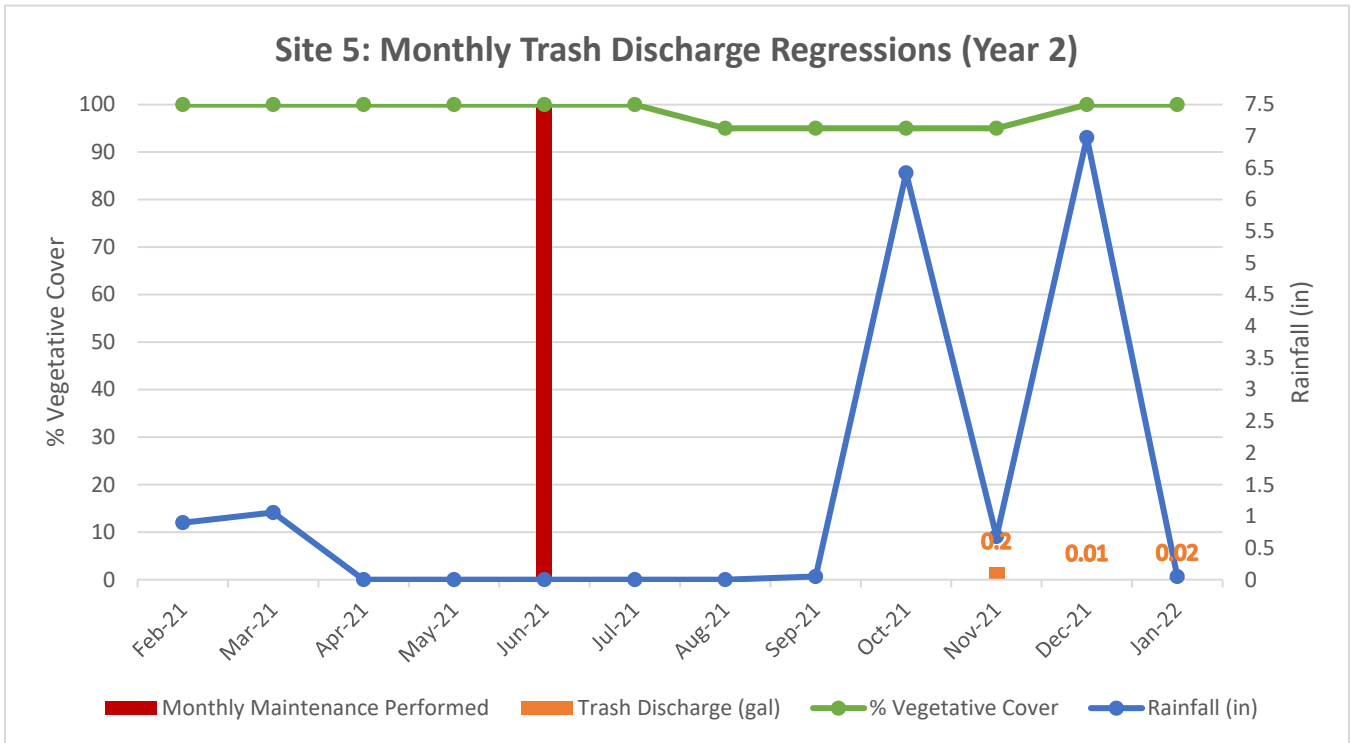
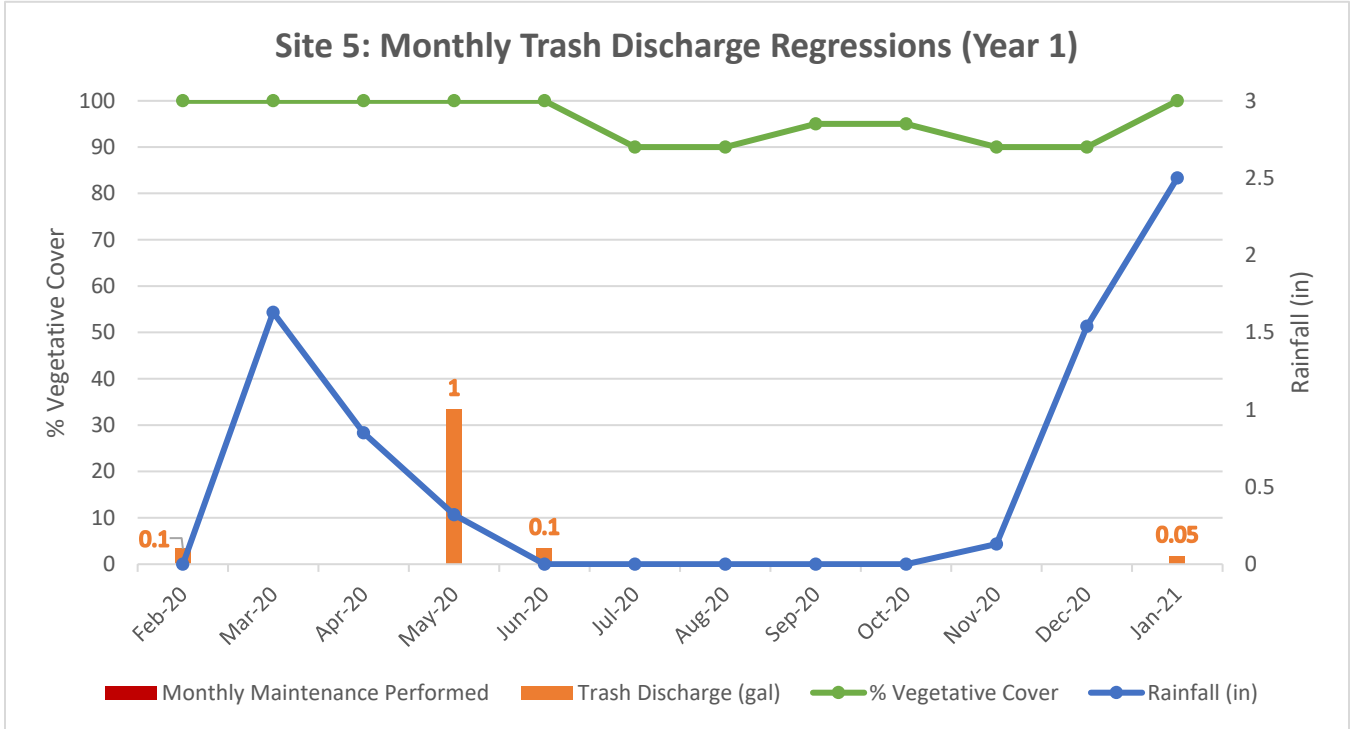

Data Summary – Site 6

Site ID (Name): 6				
Caltrans District: 4	County: Santa Clara	Route/PM: I-280 / 4.667	RWQCB (#): 2	Lat/Long: 37.316, -121.952

	Month/Year	Trash Discharge (gal)	Trash Generation Rate (gal/ac/yr)	Rainfall (in)	% Vegetative Cover	Month Maintenance Performed
Year 1	Feb-20	0.2		0	70	1
	Mar-20	-		2.06	80	0
	Apr-20	-		1.2	90	0
	May-20	0.5		0.13	90	1
	Jun-20	0.2		0	90	0
	Jul-20	0.2		0	90	0
	Aug-20	0		0	90	1
	Sep-20	0		0	90	1
	Oct-20	0		0	80	1
	Nov-20	0		0.12	75	1
	Dec-20	0		0.84	50	1
	Jan-21	0.05		1.58	50	0
	Totals	1.15	0.70	5.93	N/A	7
Year 2	Feb-21	0		0.32	75	1
	Mar-21	0		1.15	90	0
	Apr-21	0		0	90	1
	May-21	0		0	90	1
	Jun-21	0		0	90	1
	Jul-21	0		0	90	1
	Aug-21	0		0	90	1
	Sep-21	0		0	90	1
	Oct-21	0		2.16	90	0
	Nov-21	0.01		0.13	90	0
	Dec-21	0		2.81	95	1
	Jan-22	0		0	100	0
	Totals	0.01	0.01	6.57	N/A	8

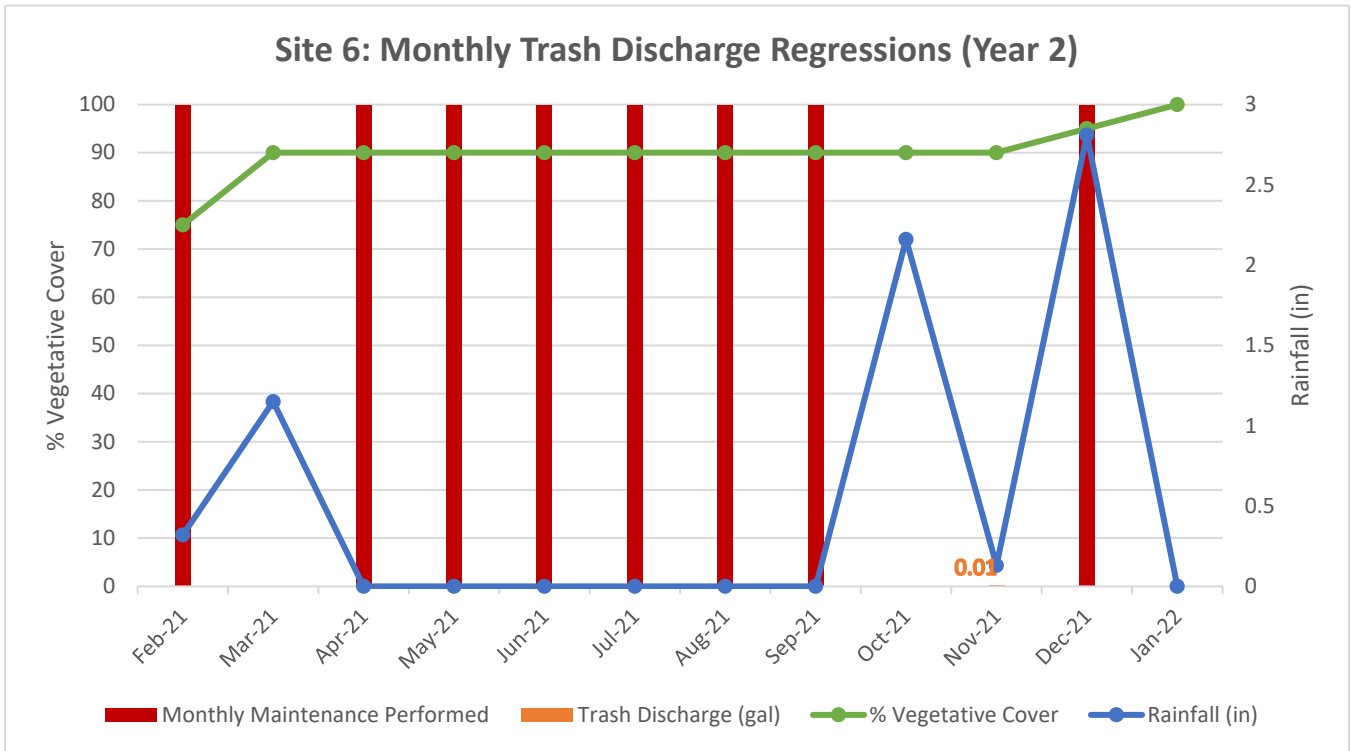
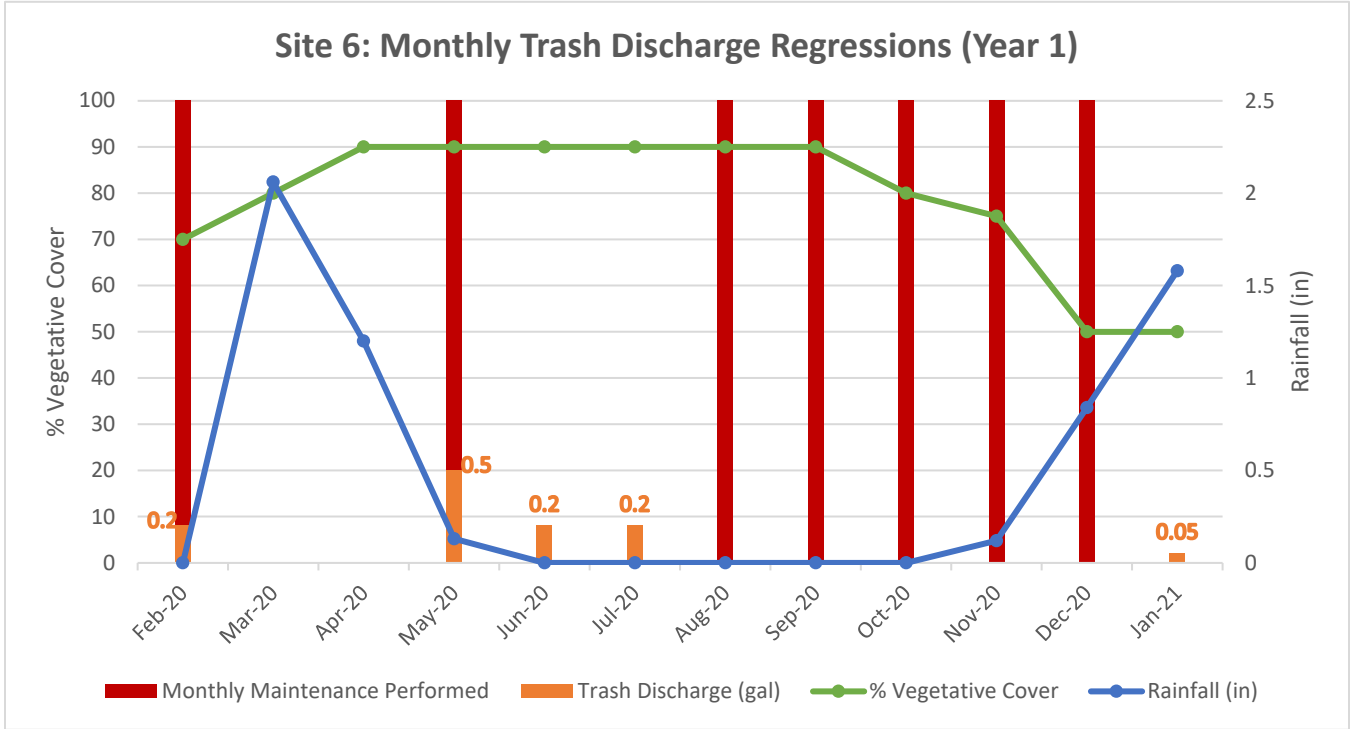

Data Summary – Site 7

Site ID (Name): 7				
Caltrans District: 4	County: Contra Costa	Route/PM: I-580 / R2.853	RWQCB (#): 2	Lat/Long: 37.922, -122.347

	Month/Year	Trash Discharge (gal)	Trash Generation Rate (gal/ac/yr)	Rainfall (in)	% Vegetative Cover	Month Maintenance Performed
Year 1	Feb-20	0		0	100	0
	Mar-20	-		1.51	100	0
	Apr-20	-		0.91	100	0
	May-20	3		0.44	100	0
	Jun-20	0.02		0	100	0
	Jul-20	0.2		0	100	0
	Aug-20	0.01		0	100	0
	Sep-20	0.01		0	90	0
	Oct-20	0.05		0	90	0
	Nov-20	0.5		0.17	90	0
	Dec-20	0.1		1.05	95	0
	Jan-21	0.5		2.42	95	0
	Totals	4.39	4.03	6.5	N/A	0
Year 2	Feb-21	0		1.75	100	1
	Mar-21	0		1.62	80	0
	Apr-21	0		0	80	0
	May-21	0		0	80	1
	Jun-21	0		0	80	0
	Jul-21	0		0	80	0
	Aug-21	0		0	80	0
	Sep-21	0		0	80	1
	Oct-21	0		5.32	90	1
	Nov-21	0.01		0.89	90	0
	Dec-21	0.05		8.93	95	0
	Jan-22	0.04		0.25	100	0
	Totals	0.1	0.09	18.76	N/A	4

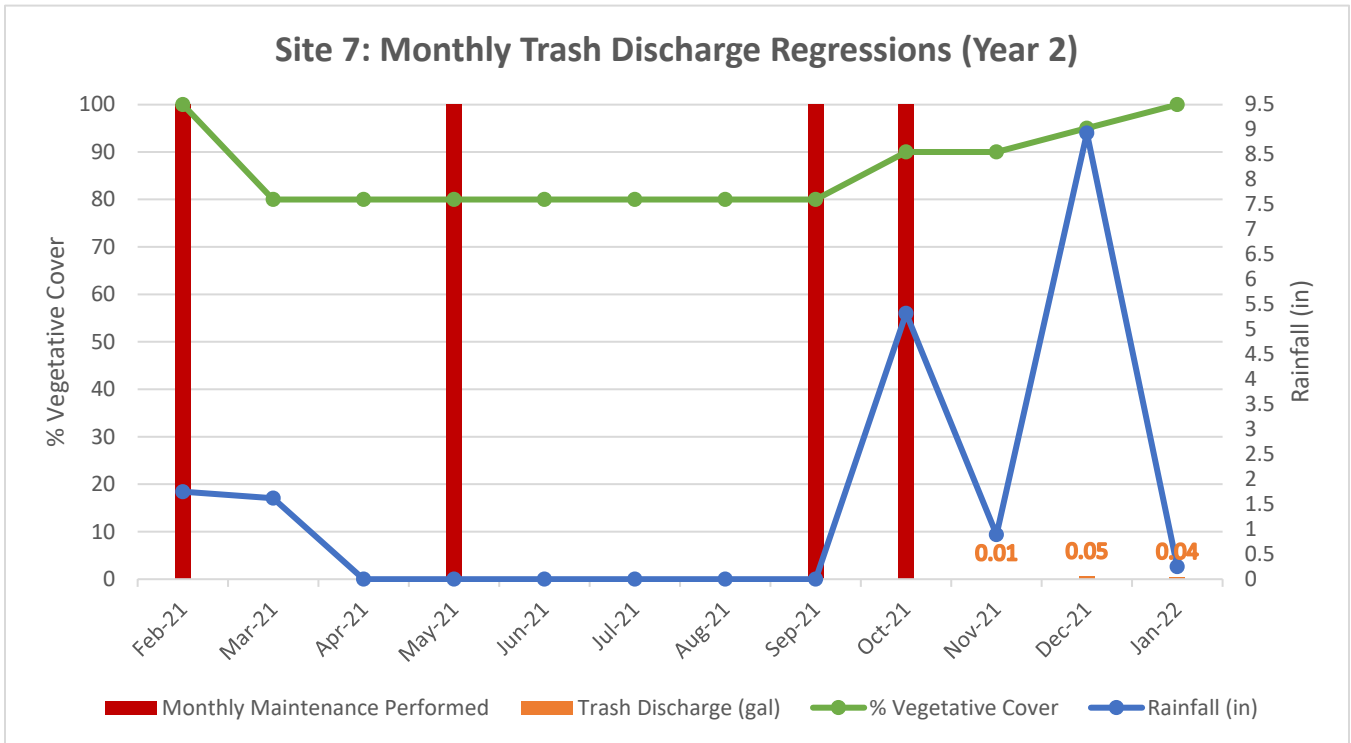
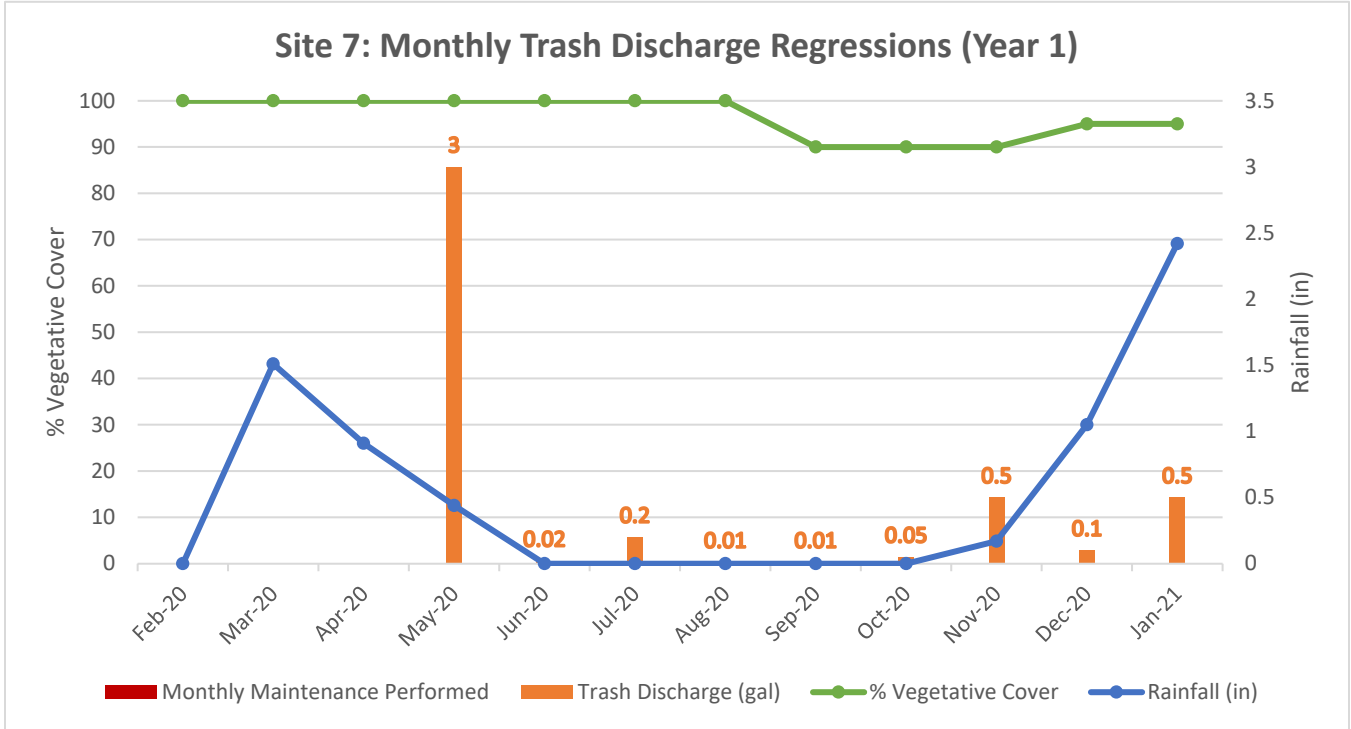

Data Summary – Site 8

Site ID (Name): 8				
Caltrans District: 4	County: Sonoma	Route/PM: US-101 / 3.723	RWQCB (#): 2	Lat/Long: 38.234, -122.618

	Month/Year	Trash Discharge (gal)	Trash Generation Rate (gal/ac/yr)	Rainfall (in)	% Vegetative Cover	Month Maintenance Performed
Year 1	Feb-20	0	0.00	0	100	0
	Mar-20	-		1.05	100	0
	Apr-20	-		1.19	100	0
	May-20	0		1.37	100	0
	Jun-20	0		0	95	0
	Jul-20	0		0	95	1
	Aug-20	0		0	95	1
	Sep-20	0		0	90	1
	Oct-20	0		0	90	0
	Nov-20	0		0.17	90	0
	Dec-20	0		3.02	90	1
	Jan-21	0		3.7	95	0
		Totals		0	0.00	10.5
Year 2	Feb-21	0	0.00	1.73	95	0
	Mar-21	0		2.65	95	0
	Apr-21	0		0	100	1
	May-21	0		0	100	1
	Jun-21	0		0	100	0
	Jul-21	0		0	100	0
	Aug-21	0		0	100	0
	Sep-21	0		0.15	100	0
	Oct-21	0		10.69	100	0
	Nov-21	0		2.97	100	0
	Dec-21	0		7.26	100	0
	Jan-22	0		0.61	100	0
		Totals		0	0.00	26.06

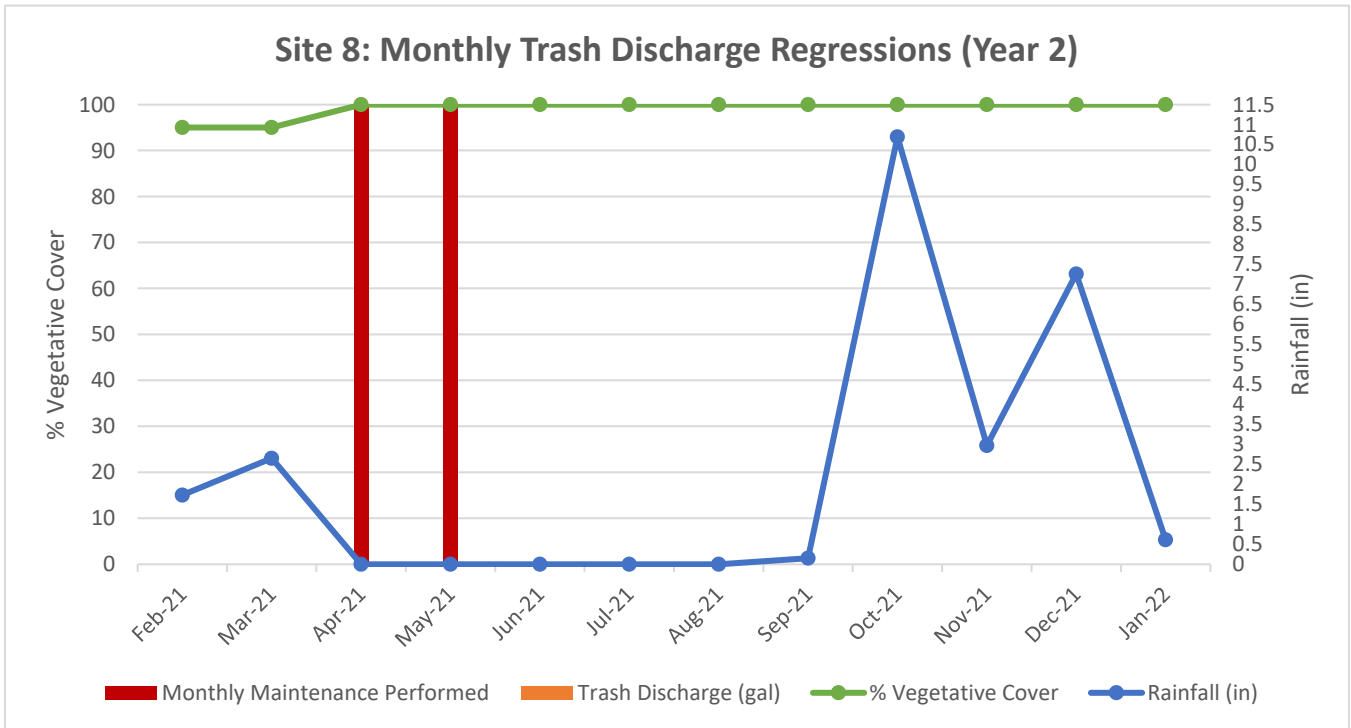
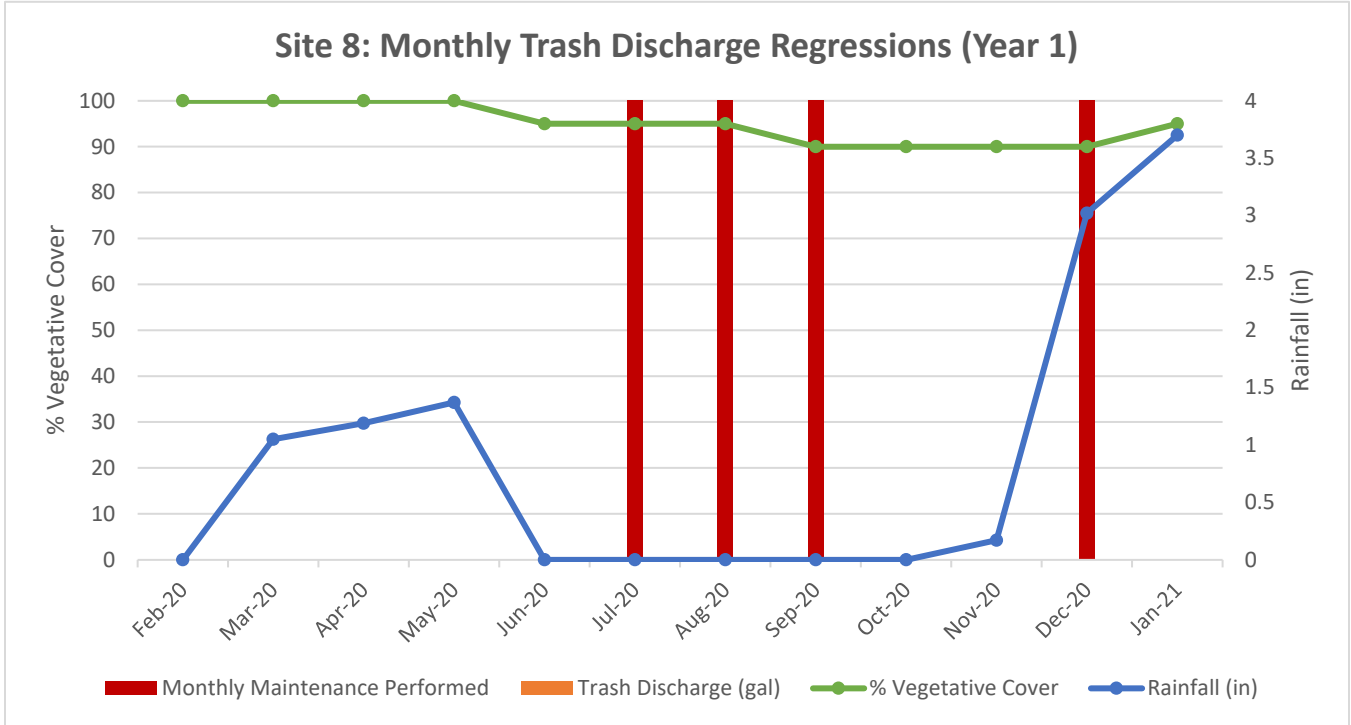

Data Summary – Site 9

Site ID (Name): 9				
Caltrans District: 3	County: Sacramento	Route/PM: I-80 / 9.331	RWQCB (#): 5	Lat/Long: 38.575, -121.575

	Month/Year	Trash Discharge (gal)	Trash Generation Rate (gal/ac/yr)	Rainfall (in)	% Vegetative Cover	Month Maintenance Performed
Year 1	Feb-20	0.75		0	95	0
	Mar-20	-		1.63	95	0
	Apr-20	-		0.85	100	0
	May-20	0		0.32	100	0
	Jun-20	0.05		0	100	0
	Jul-20	0		0	100	0
	Aug-20	0.1		0	100	0
	Sep-20	0		0	90	0
	Oct-20	0		0	90	0
	Nov-20	0		0.13	80	0
	Dec-20	0		1.54	90	1
	Jan-21	0.05		2.5	90	0
	Totals	0.95	0.59	6.97	N/A	1
Year 2	Feb-21	0		0.9	95	0
	Mar-21	0		1.06	90	0
	Apr-21	0		0	90	0
	May-21	0		0	90	0
	Jun-21	0		0	90	0
	Jul-21	0		0	90	0
	Aug-21	0		0	90	0
	Sep-21	0		0.05	90	0
	Oct-21	0		6.42	95	0
	Nov-21	0.1		0.68	95	0
	Dec-21	0.01		6.98	100	0
	Jan-22	0.01		0.05	95	0
	Totals	0.12	0.08	16.14	N/A	0

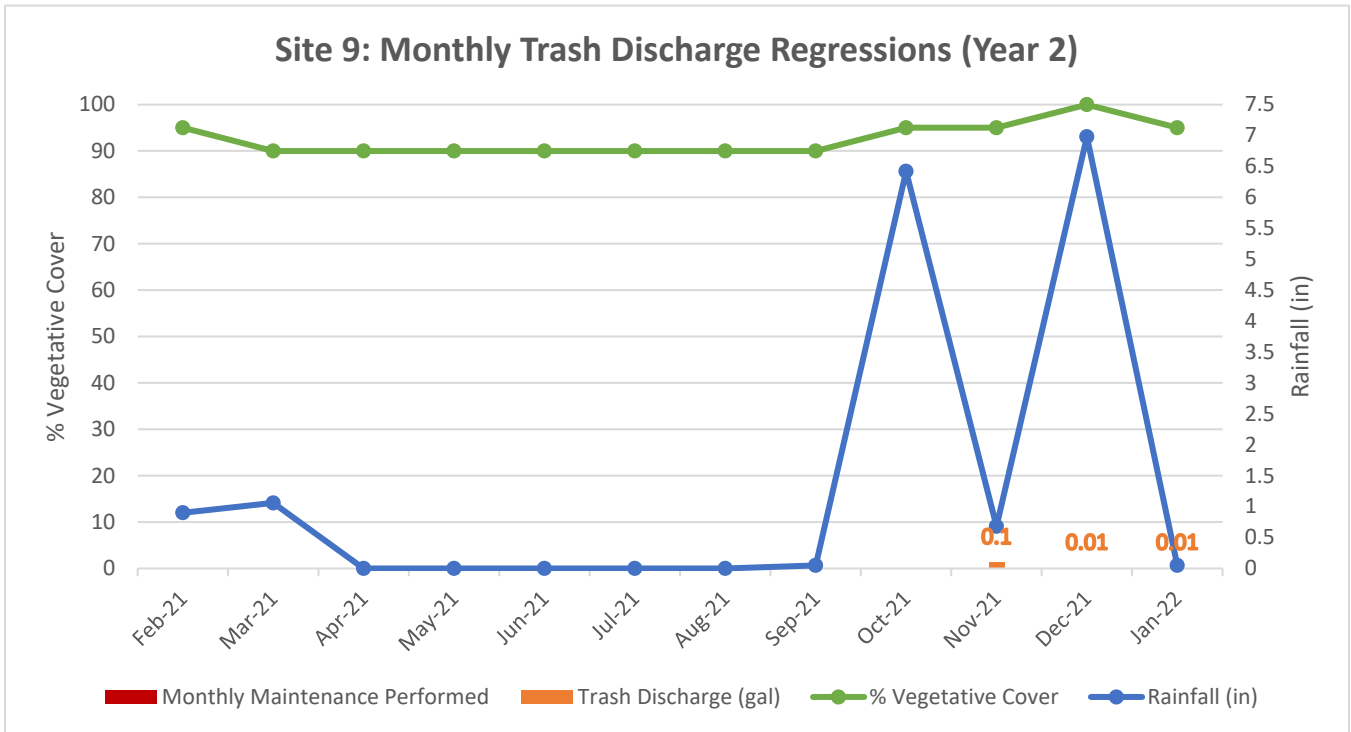
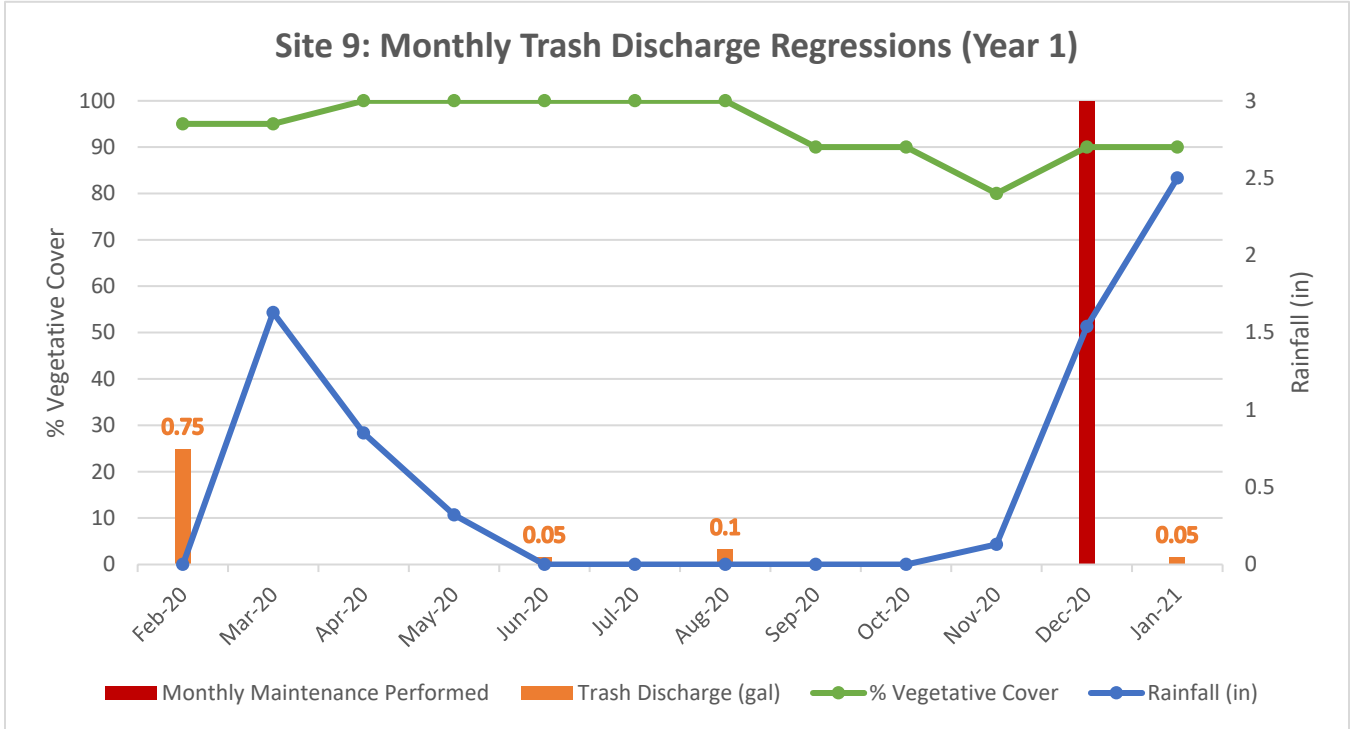

Data Summary – Site 10

Site ID (Name): 10				
Caltrans District: 4	County: Santa Clara	Route/PM: SR-237 / R5.763	RWQCB (#): 2	Lat/Long: 37.415, -121.979

	Month/Year	Trash Discharge (gal)	Trash Generation Rate (gal/ac/yr)	Rainfall (in)	% Vegetative Cover	Month Maintenance Performed
Year 1	Feb-20	0.1	0.24	0	80	0
	Mar-20	-		2.06	80	0
	Apr-20	-		1.2	80	0
	May-20	0.1		0.13	80	1
	Jun-20	0.2		0	80	0
	Jul-20	0.01		0	75	0
	Aug-20	0		0	80	0
	Sep-20	0		0	80	1
	Oct-20	0		0	80	0
	Nov-20	0		0.12	95	0
	Dec-20	0		0.84	95	0
	Jan-21	0.05		1.58	95	0
	Totals	0.46		0.24	5.93	N/A
Year 2	Feb-21	0	0.16	0.32	100	0
	Mar-21	0		1.15	100	0
	Apr-21	0		0	10	0
	May-21	0		0	10	0
	Jun-21	0		0	20	0
	Jul-21	0		0	20	0
	Aug-21	0		0	20	0
	Sep-21	0		0	40	0
	Oct-21	0		2.16	40	0
	Nov-21	0.25		0.13	50	0
	Dec-21	0.02		2.81	30	0
	Jan-22	0.03		0	50	0
	Totals	0.3		0.16	6.57	N/A

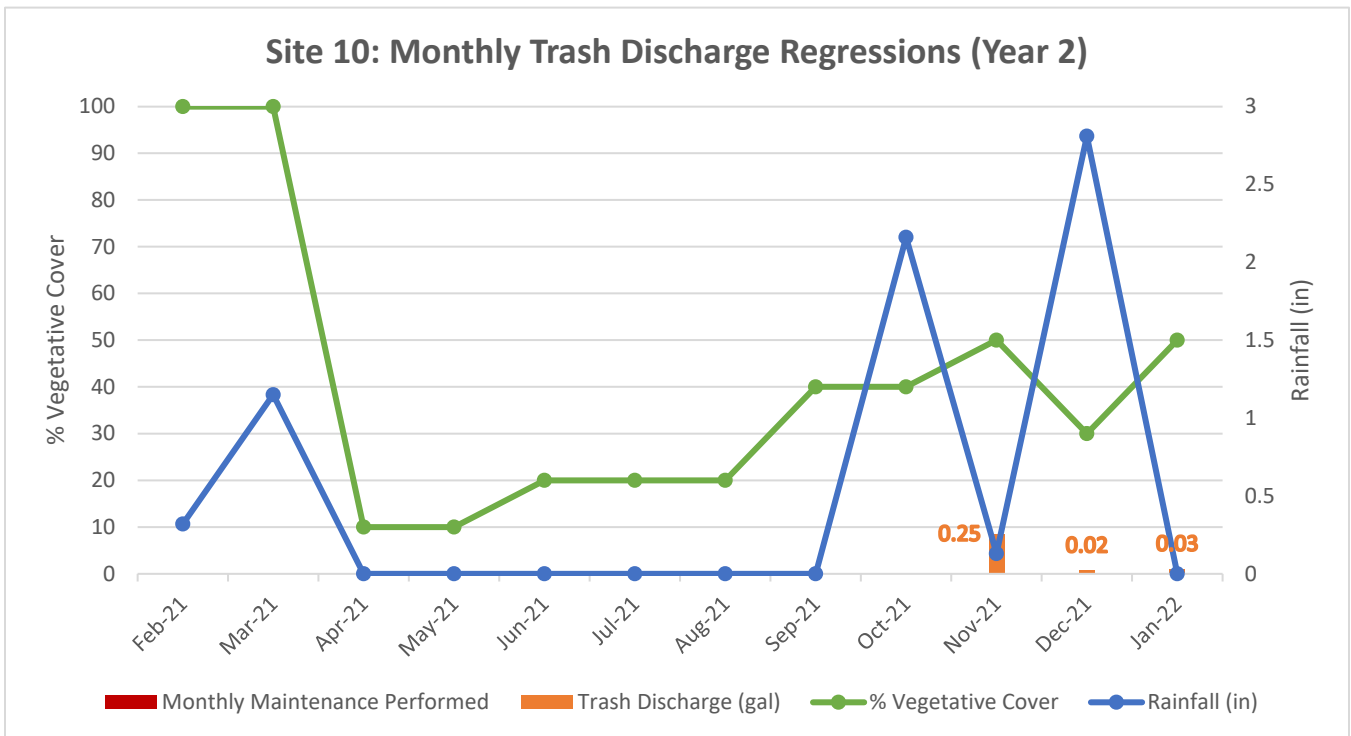
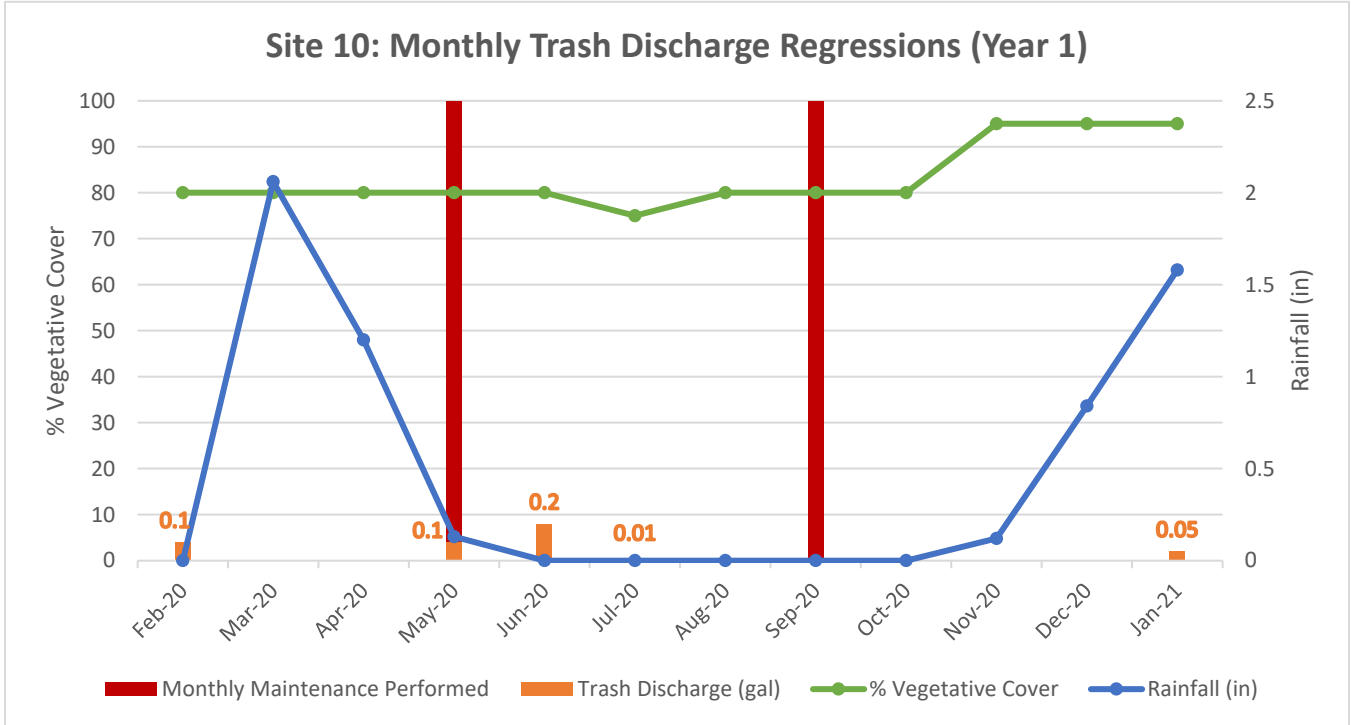

Data Summary – Site 11

Site ID (Name): 11				
Caltrans District: 12	County: Orange	Route/PM: I-5 / 44.164	RWQCB (#): 8	Lat/Long: 33.873, -118.008

	Month/Year	Trash Discharge (gal)	Trash Generation Rate (gal/ac/yr)	Rainfall (in)	% Vegetative Cover	Month Maintenance Performed
Year 1	Feb-20	-	0.00	-	-	-
	Mar-20	-		-	-	-
	Apr-20	-		-	-	-
	May-20	-		-	-	-
	Jun-20	-		-	-	-
	Jul-20	0		0	80	0
	Aug-20	0		0	80	1
	Sep-20	0		0	25	0
	Oct-20	0		0	40	1
	Nov-20	0		0.02	50	0
	Dec-20	0		1.07	80	0
	Jan-21	0		1.76	40	0
	Totals	0		0.00	2.85	N/A
Year 2	Feb-21	0	0.00	0.03	50	1
	Mar-21	0		1.16	50	0
	Apr-21	0		0	70	1
	May-21	0		0.15	50	1
	Jun-21	0		0	60	1
	Jul-21	0		0	50	0
	Aug-21	0		0	60	0
	Sep-21	0		0.1	50	0
	Oct-21	0		0.79	70	0
	Nov-21	0		0	60	1
	Dec-21	0		4.79	70	0
	Jan-22	0		0.06	75	0
	Totals	0		0.00	7.08	N/A

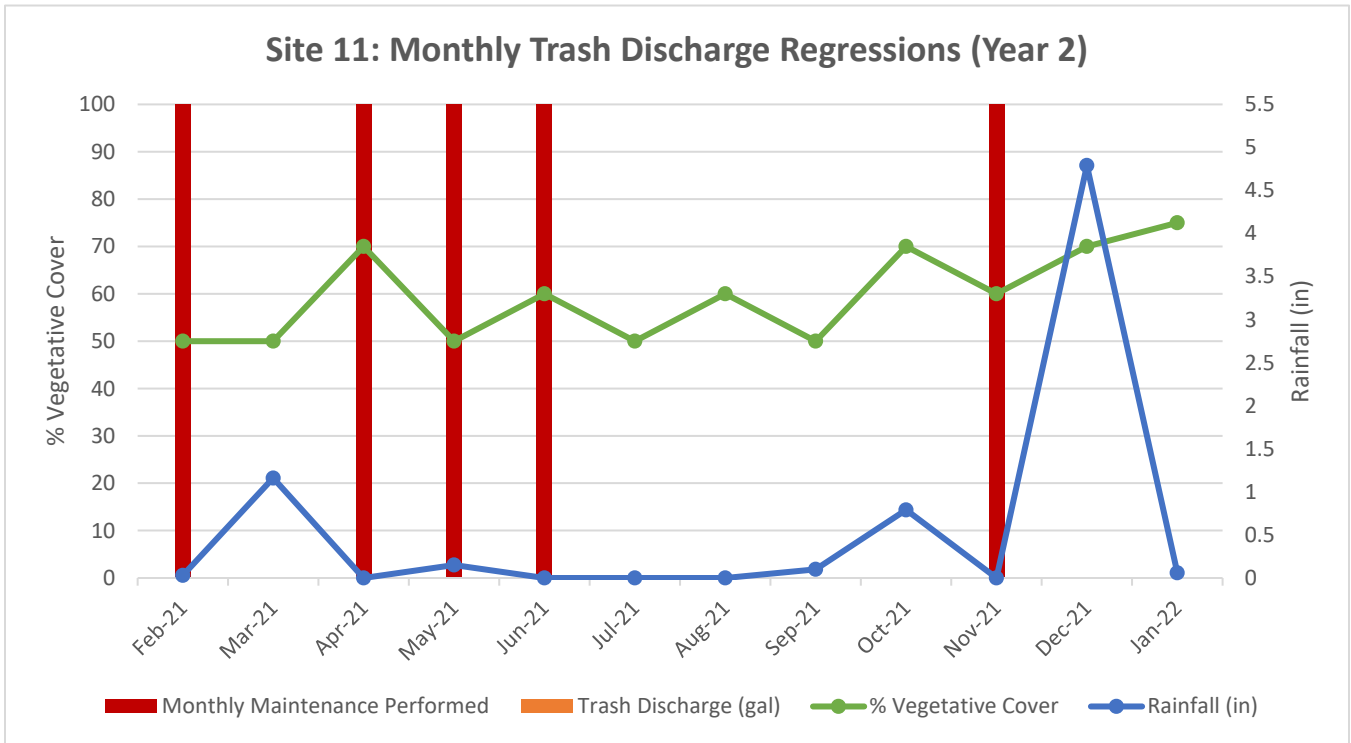
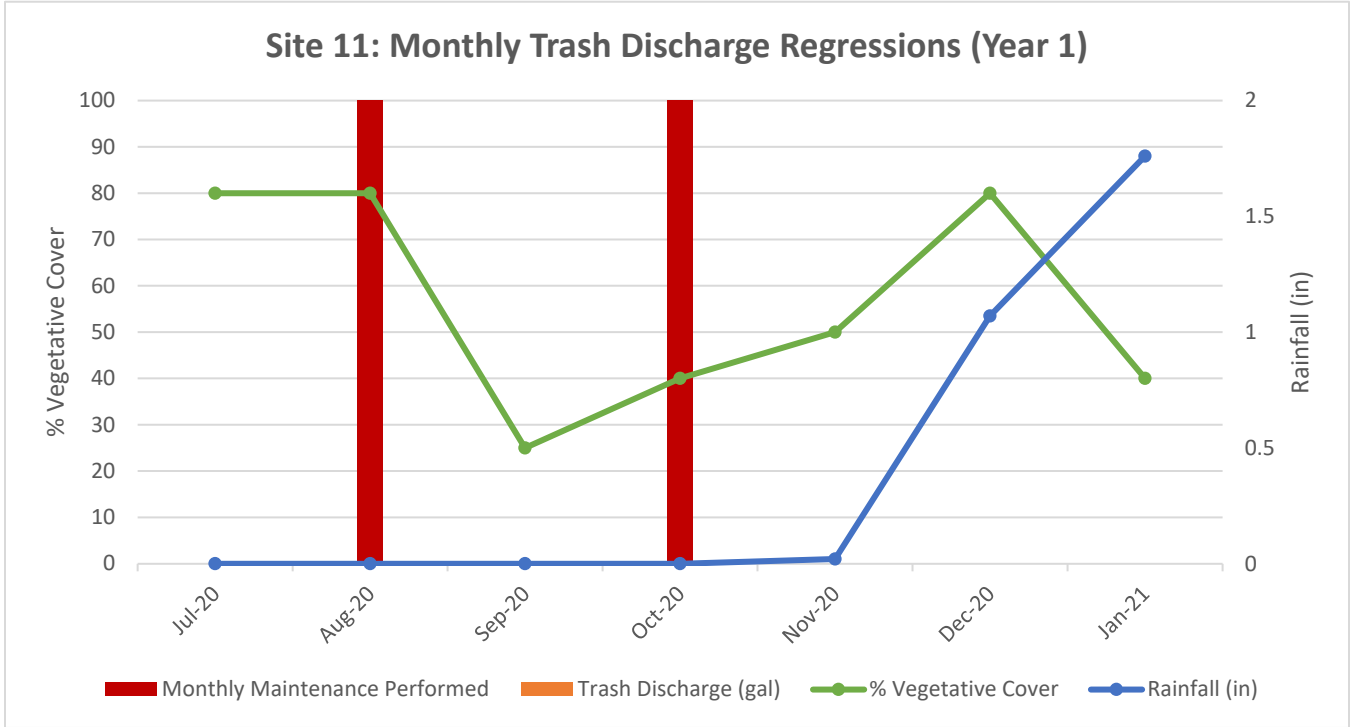

Data Summary – Site 12

Site ID (Name): 12				
Caltrans District: 12	County: Orange	Route/PM: I-5 / 40.648	RWQCB (#): 8	Lat/Long: 33.845, -117.958

	Month/Year	Trash Discharge (gal)	Trash Generation Rate (gal/ac/yr)	Rainfall (in)	% Vegetative Cover	Month Maintenance Performed
Year 1	Feb-20	-		-	-	-
	Mar-20	-		-	-	-
	Apr-20	-		-	-	-
	May-20	-		-	-	-
	Jun-20	-		-	-	-
	Jul-20	0		0	95	0
	Aug-20	0		0	95	0
	Sep-20	0		0	95	0
	Oct-20	0		0	95	0
	Nov-20	0.25		0.02	95	0
	Dec-20	0		1.07	95	1
	Jan-21	0		1.76	90	0
	Totals	0.25	0.17	2.85	N/A	1
Year 2	Feb-21	0.5		0.03	95	1
	Mar-21	0		1.16	90	1
	Apr-21	0		0	90	1
	May-21	0		0.15	95	1
	Jun-21	0		0	90	1
	Jul-21	0		0	95	0
	Aug-21	0		0	95	1
	Sep-21	0		0.1	95	0
	Oct-21	0		0.79	95	0
	Nov-21	0		0	95	1
	Dec-21	0		4.79	95	0
	Jan-22	0		0.06	95	1
	Totals	0.5	0.35	7.08	N/A	8

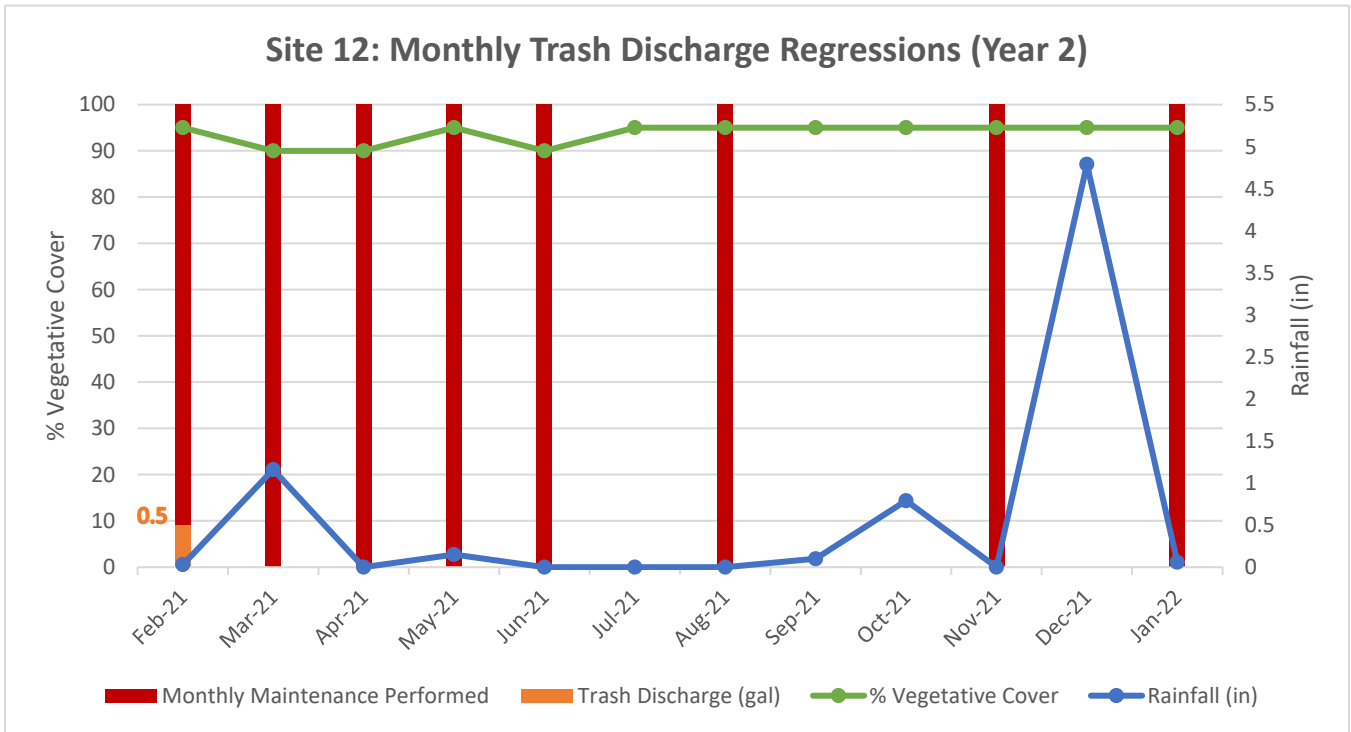
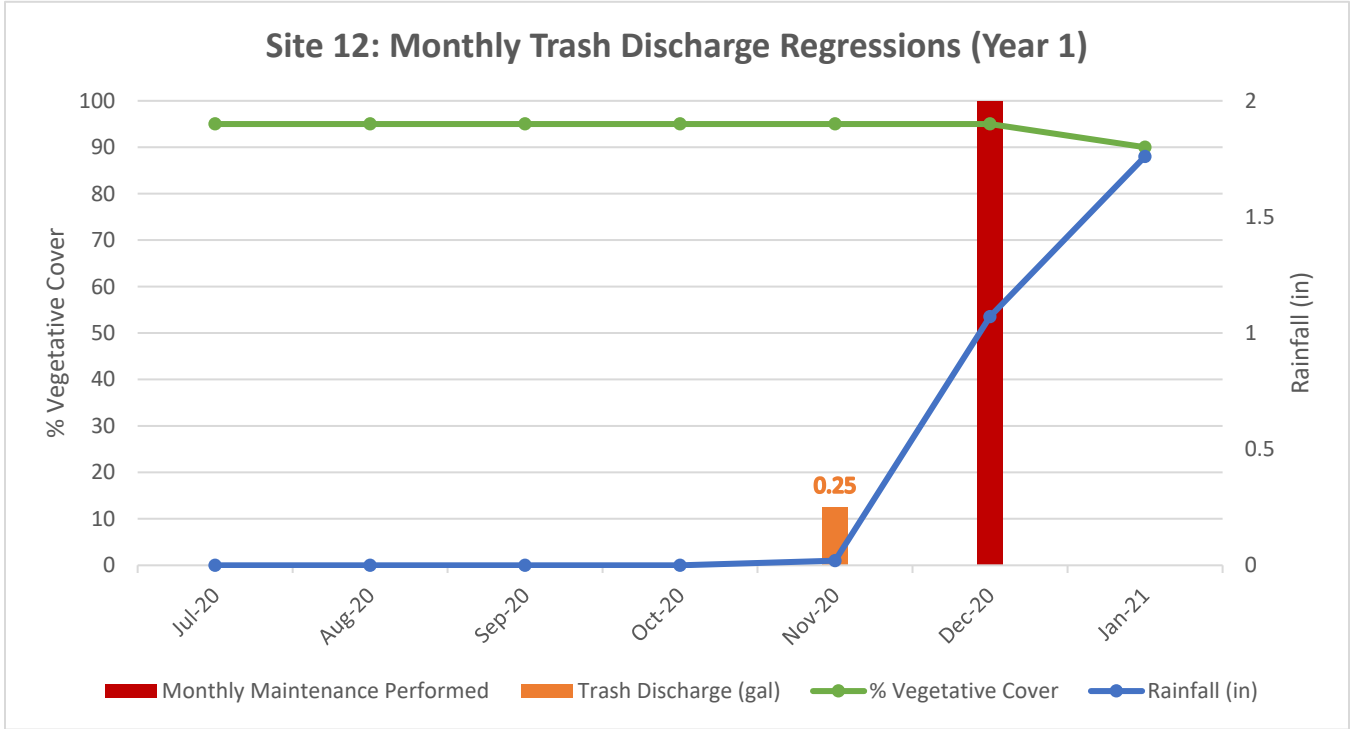

Data Summary – Site 13

Site ID (Name): 13				
Caltrans District: 12	County: Orange	Route/PM: SR-22 / R7.924	RWQCB (#): 8	Lat/Long: 33.769, -117.919

	Month/Year	Trash Discharge (gal)	Trash Generation Rate (gal/ac/yr)	Rainfall (in)	% Vegetative Cover	Month Maintenance Performed
Year 1	Feb-20	-		-	-	0
	Mar-20	-		-	-	0
	Apr-20	-		-	-	0
	May-20	-		-	-	0
	Jun-20	-		-	-	0
	Jul-20	0		0	75	0
	Aug-20	0		0	75	1
	Sep-20	0		0	75	1
	Oct-20	0.01		0	60	0
	Nov-20	0.01		0.02	60	1
	Dec-20	0		1.07	70	1
	Jan-21	0.1		1.76	80	0
	Totals	0.12	0.07	2.85	N/A	4
Year 2	Feb-21	0		0.03	70	0
	Mar-21	0		1.16	75	0
	Apr-21	0		0	70	0
	May-21	0		0.15	60	1
	Jun-21	0		0	60	1
	Jul-21	0		0	70	0
	Aug-21	0		0	60	0
	Sep-21	0		0.1	70	0
	Oct-21	0		0.79	70	0
	Nov-21	0		0	70	0
	Dec-21	0		4.79	65	1
	Jan-22	0		0.06	70	0
	Totals	0	0.00	7.08	N/A	3

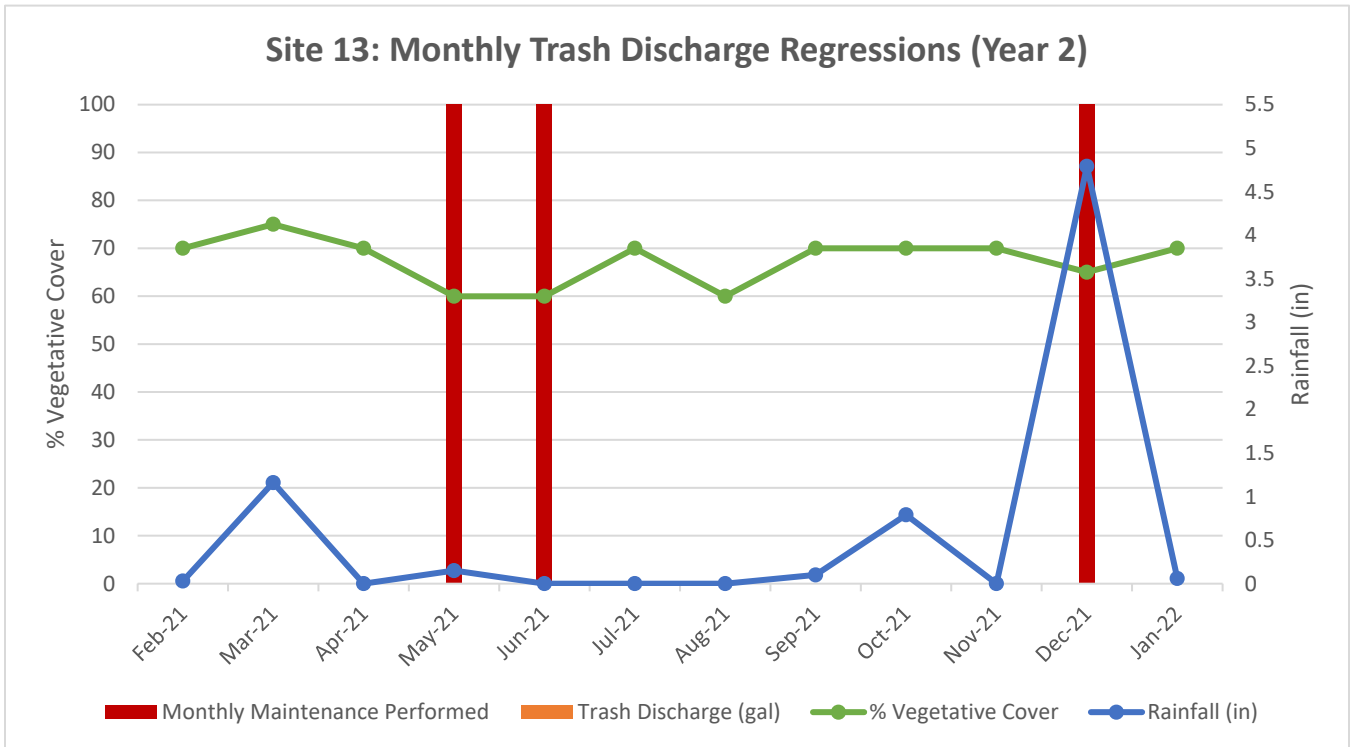
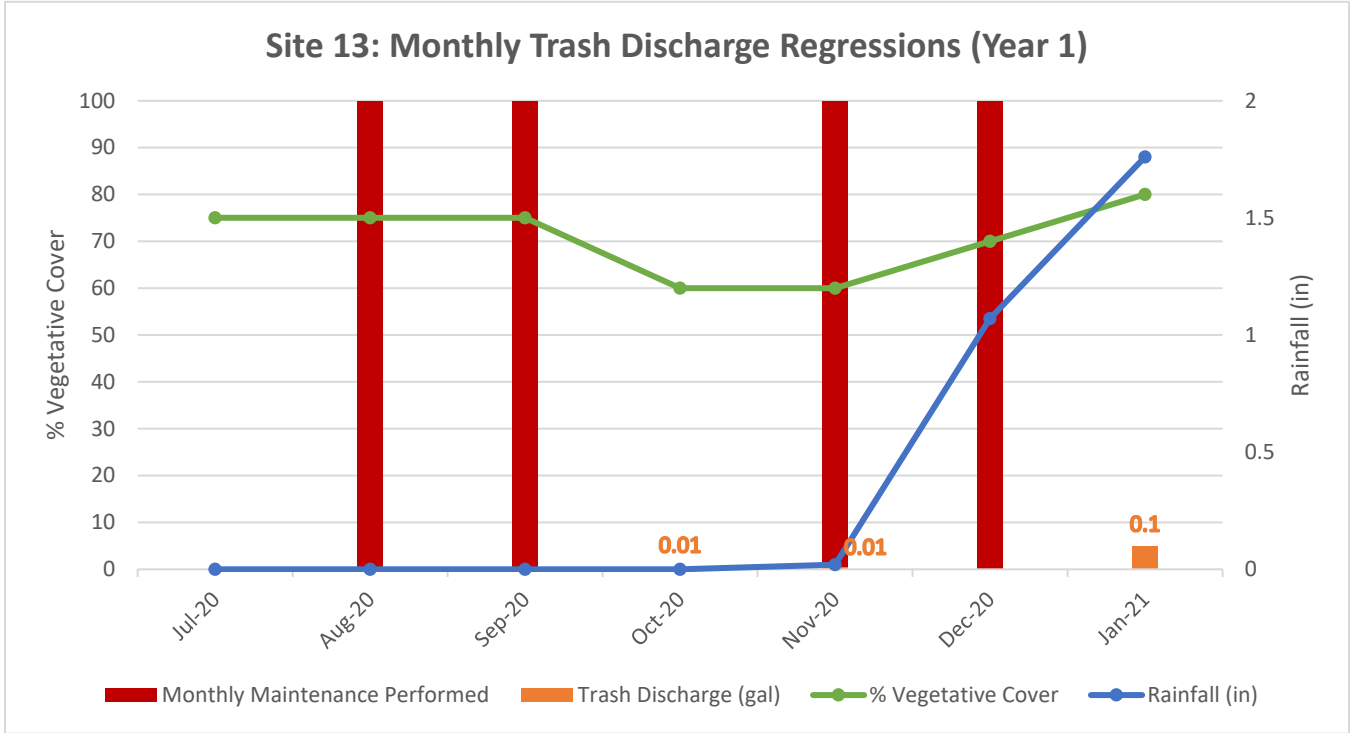

Data Summary – Site 14

Site ID (Name): 14				
Caltrans District: 12	County: Orange	Route/PM: SR-57 / 14.885	RWQCB (#): 8	Lat/Long: 33.840, -117.876

	Month/Year	Trash Discharge (gal)	Trash Generation Rate (gal/ac/yr)	Rainfall (in)	% Vegetative Cover	Month Maintenance Performed
Year 1	Feb-20	-		-	-	-
	Mar-20	-		-	-	-
	Apr-20	-		-	-	-
	May-20	-		-	-	-
	Jun-20	-		-	-	-
	Jul-20	0.01		0	65	0
	Aug-20	0.01		0	65	0
	Sep-20	0.05		0	65	0
	Oct-20	0.2		0	60	0
	Nov-20	0.2		0.02	50	0
	Dec-20	0.3		1.07	50	1
	Jan-21	0.1		1.76	40	0
		Totals		0.87	0.40	2.85
Year 2	Feb-21	0.1		0.03	50	1
	Mar-21	0.05		1.16	50	0
	Apr-21	0.01		0	50	0
	May-21	0.05		0.15	50	0
	Jun-21	0.01		0	50	0
	Jul-21	0.01		0	60	0
	Aug-21	0.01		0	50	0
	Sep-21	0.01		0.1	50	0
	Oct-21	0		0.79	50	0
	Nov-21	0.05		0	50	0
	Dec-21	0.01		4.79	50	0
	Jan-22	0.01		0.06	50	1
		Totals		0.32	0.15	7.08

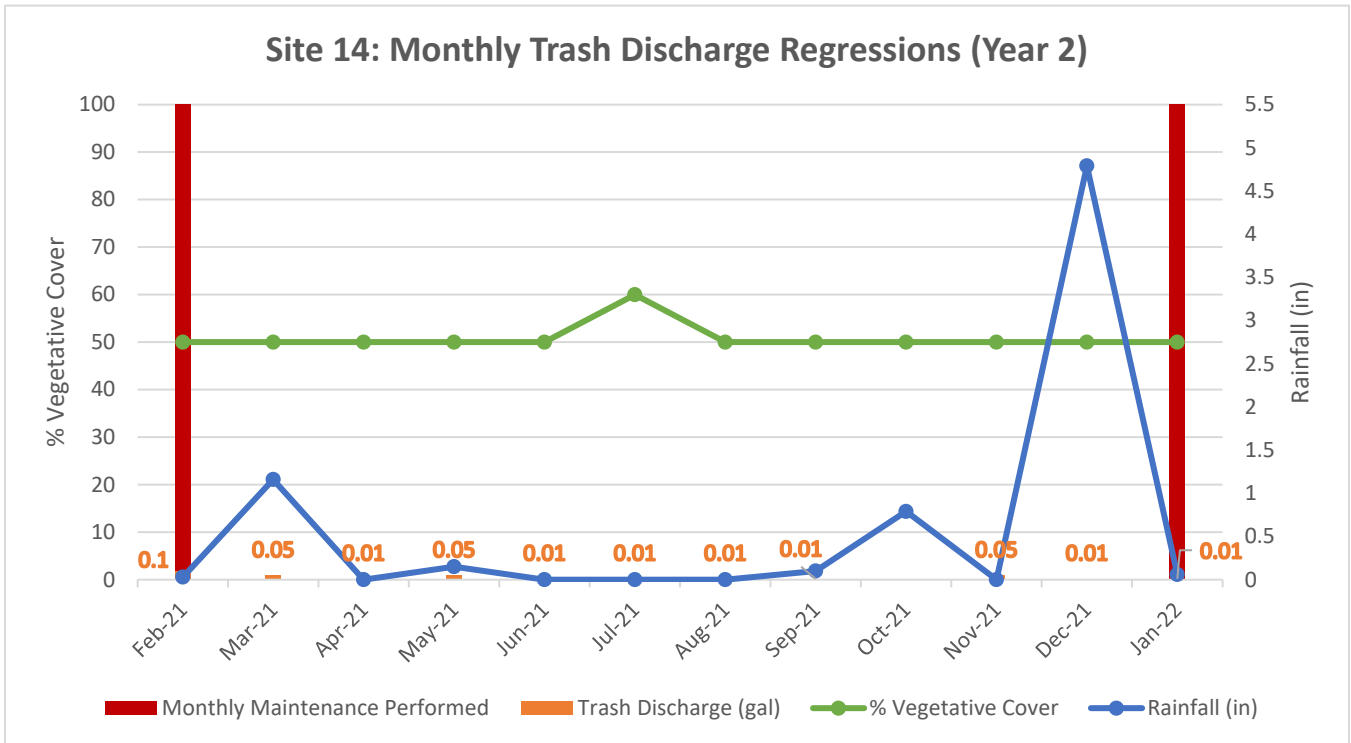
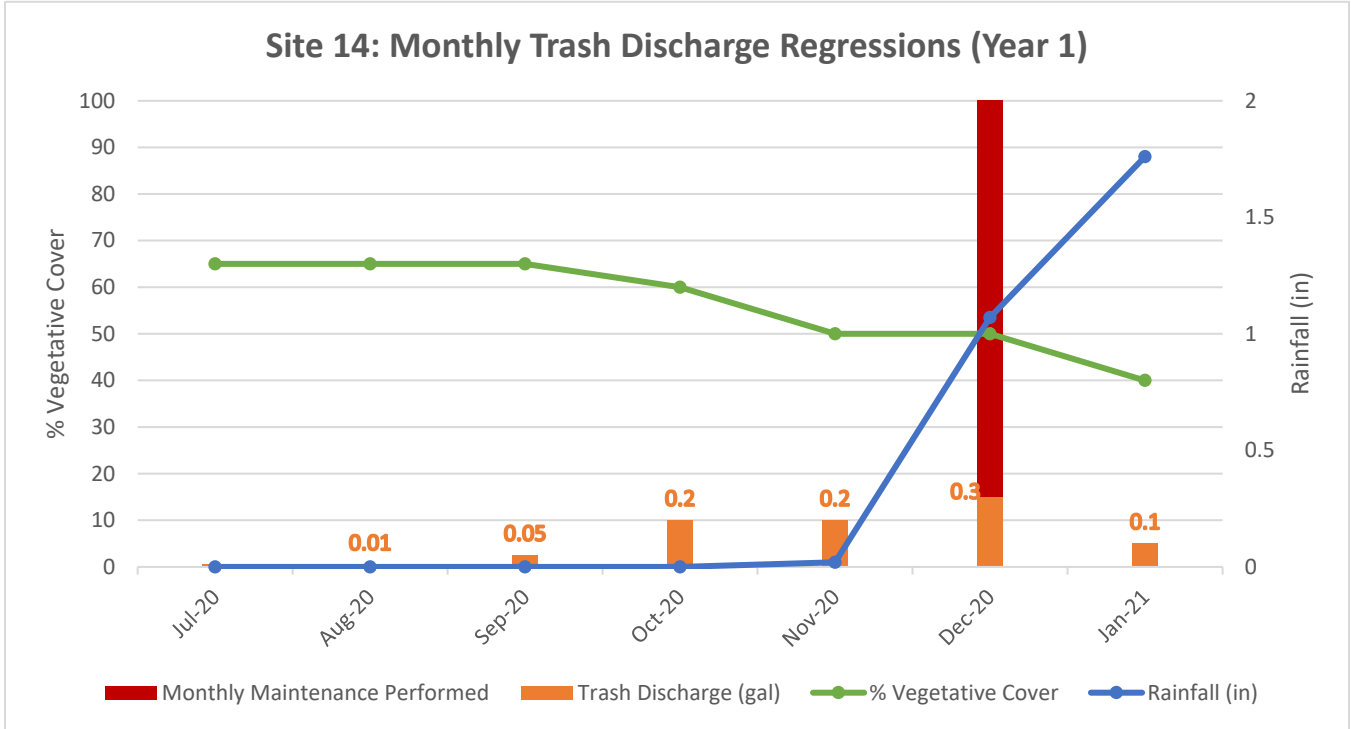



VEGETATION CONTROL COMPLIANCE DELINEATION PROTOCOL

The purpose of this document is to describe the California Department of Transportation's (Caltrans) vegetation control delineation and monitoring protocol to identify areas of qualifying credit to demonstrate compliance with both Attachment E of the June 22, 2022 Caltrans National Pollutant Discharge Elimination System (NPDES) Statewide Stormwater Permit (Permit) and the San Francisco Regional Water Quality Control Board issued Cease-and-Desist Order (Order No. R2-2019-0007). Both the permit and CDO requires Caltrans to demonstrate full capture equivalency at all significant trash generating areas (STGAS) where certified full capture systems are not installed.

Executive Summary

Caltrans acknowledges that additional actions are required prior to submitting credit for vegetation control. These actions have been discussed at regular meeting with the San Francisco Bay Regional Board and in a comment letter received in response to the Caltrans March 2023 Trash Discharge CDO Compliance Action Plan.

The Vegetation Control report is being updated to address the following actions:

1. Additional trash volume monitoring data points are being obtained from the inlet inserts to determine if vegetation was as effective during the 2023 above average wet weather season compared to the dryer period between 2020-2022.
2. Updating the associated rainfall intensity data since the last trash volume monitoring event in early 2022.
3. Disclosure of the delineation protocol including use of artificial intelligence that integrates high resolution digital terrain model along with drainage information to identify treatment shed areas and flow paths.
4. Quality Assurance and Quality Control protocols
5. Identification of roadside features including vegetation type and density and other, equally effective, pervious features such as rocks, mulch, etc.
6. Field verification requirements
7. Consideration of various engineering control options at the discharge inlet points, such as concentrated flow paths through the vegetated areas, to increase confidence in meeting full trash capture equivalency.
8. Identifying the routine maintenance commitment to collect trash so that it does not degrade.



In theory, if the amount of trash trapped by the certified full capture device is less than 5 gallons/acre/year at each inlet, full capture equivalence would be demonstrated. 5 gallons/acre/year represents the high point of what is considered “low” trash generation established by the OVTA and accepted by the both the Permit and by the San Francisco Regional Water Board’s Municipal Regional Permit for which the CDO was issued to enforce. If full capture equivalence is demonstrated, certified full capture systems are not required to be installed at vegetated areas that are similar to those selected for the study.

1.0 Background

This protocol describes the methodology used for identifying similar sites in Caltrans right-of-way (ROW) that are representative of the vegetation trash control pilot study sites and will be claimed for compliance credit. Areas are calculated using a semi-automated process that leverages best available spatial information and aerial imagery. Identifying areas of potential compliance credit via flow through vegetation requires knowledge of the following items:

1. Where vegetation occurs in the ROW
2. How surface water flows throughout the ROW
3. The trash rating assigned to the ROW
4. The location of the storm inlets that receive surface water runoff

Identification of potential compliance credit begins with identifying where vegetation exists in the ROW and identifying tributary drainage areas. The processes described were performed on a district-wide scale to assist in identifying where potential credit exists.

2.0 Identification of Qualifying Vegetation

National Agriculture Imagery Program (NAIP) images and machine learning methods were combined to develop a vegetated landcover classification. To develop the vegetated landcover classification, NAIP imagery from the 2020 growing season was selected with acquisition dates ranging from April 15th, 2020 at the earliest to July 31st, 2020 at the latest. NAIP imagery contains of 4 bands (red, green, blue, and near infrared) which are widely used in the remote sensing literature for vegetation classification tasks. The imagery is also available at high resolution (0.6 meters) and is publicly available with no licensing restrictions for its use.



3.0 Artificial Intelligence Model Training

Training the supervised machine learning model required input features (NAIP imagery) and ground truth labels (landcover classification). The NAIP imagery was loaded into a geographic information system which allowed for manual delineation of vegetated and non-vegetated areas within the ROW. Labels were generated for vegetation types as part of the training dataset development, with imagery pixels being assigned a vegetated, non-vegetated, or shadow label. A “shadow” label was necessary for darker areas in the imagery which can prevent the model from making an accurate classification between vegetated and non-vegetated.

Using the trained model, each pixel of the NAIP images received one of the three classifications. Then, post processing methods were used to denoise the classifications and to impute the shadow areas with a vegetated or non-vegetated label. Additionally, iterative focal majority filters were used to remove large, shadowed areas. Any remaining shadow pixels were removed using ESRI’s “nibble” tool, which replaced shadow pixels with values of their nearest neighbors (vegetated or non-vegetated). Results were then converted from raster to polygon format. Due to the pixelated nature of the raster products, ESRI’s “Simplify Polygon” tool was used to remove relatively extraneous vertices while preserving the essential shape. A sample of the final polygons are presented below. A summary of the entire classification workflow is also provided.



Figure 1: Final Landcover Classification Polygons (gridcode 0 = non-vegetated, gridcode 2 = vegetated)



4.0 Qualifying Compliance Areas

While high and moderate resolution bare earth digital elevation models (DEMs) are available across the district, previous model delineations revealed important topographic features that drive localized hydrology are often scrubbed out of the elevation datasets. This can lead to incorrect basin delineation and subsequent vegetation credit identification. To improve the basin delineation and reduce the manual Quality Control efforts, the LiDAR point clouds were combined with existing bare earth DEMs to produce hydrologically correct DEMs for basin delineation.

4.1 Delineating Drainage Areas

Bare-earth DEMs are a by-product of LiDAR collections that are commonly used for planning and engineering works. Following common specifications, these raster products have had trees, buildings, vehicles, and other above ground features removed. However, features such as curbs and gutters, sound walls, and highway medians govern local flow paths for site level studies. A workflow was developed to extract these features and merge them with the bare-earth DEMs to create hydrologically correct DEMs. As noted in the figure below, the source LiDAR data contains the highway median and sound walls that drive local flow-paths where-as the bare-earth dem has removed these topographic features.

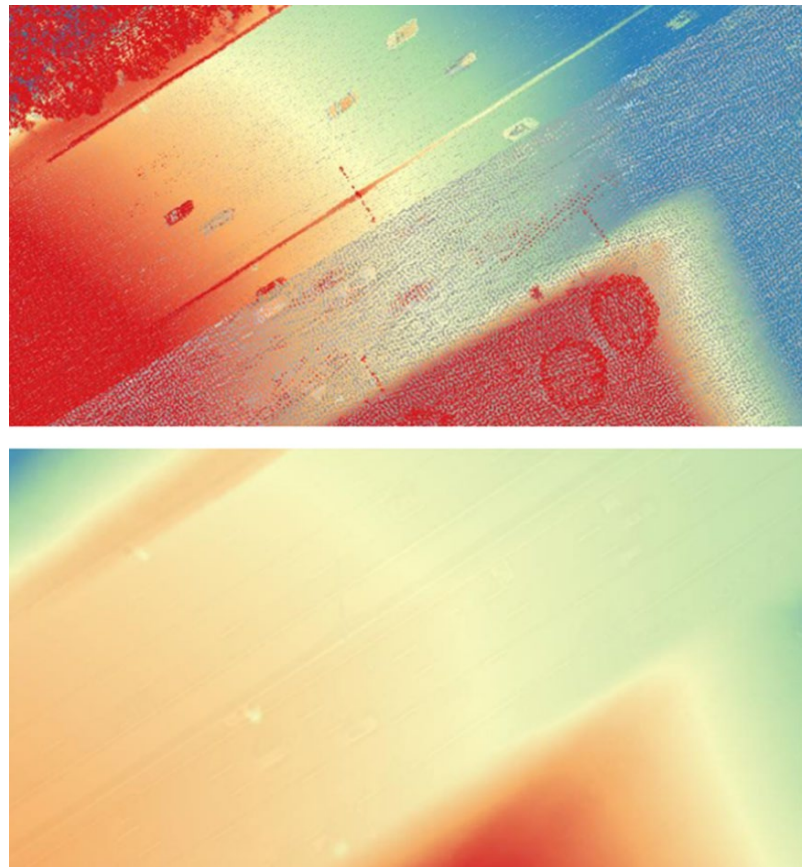

Figure 2: LiDAR point cloud with hydrologically important features (above), bare earth DEM that is missing key hydrologic features (below)



4.2 Confirming Hydraulic Connectivity

Individual drainage basins within the ROW were delineated from the hydrologically correct DEMs. The resolution varied across District 4 ROW depending on the associated LiDAR collection. Half-meter DEMs were generated where 2021 LiDAR (Alameda County Collection) was available. One-meter resolution data collected between 2016 and 2020 were available in most of the ROW. Basins were delineated inside the ROW using standard hydrologic conditioning methods to allocate flow in all areas of the DEM to drain either to a known inlet location or out of the ROW (figure 4).

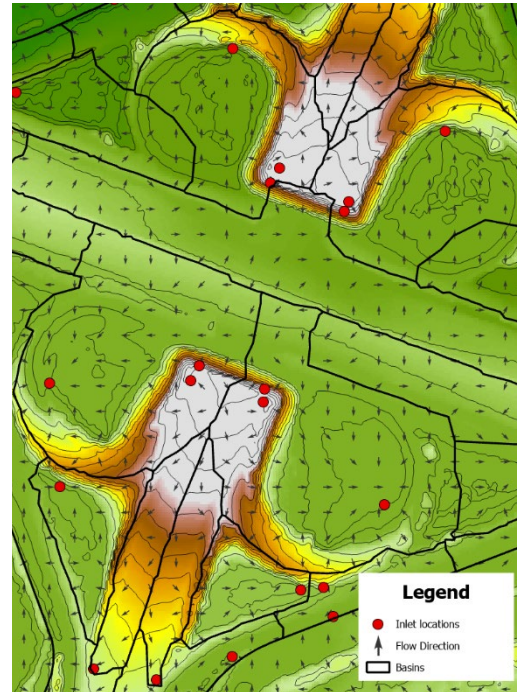

Figure 3: Example Delineated Basins through DEM Flow Allocation

4.3 Establishing Flow Path

Using the flow directions generated in the previous step, flow paths can be determined for each area in the ROW. The flow paths were then combined with the vegetation layer to produce a flow-through-vegetation layer. This layer describes the amount of vegetation at each point in the ROW that water travels through on its way to an inlet. This is visualized in Figure 5 where the colors represent the cumulative flow length through vegetation in the flow path at each point.

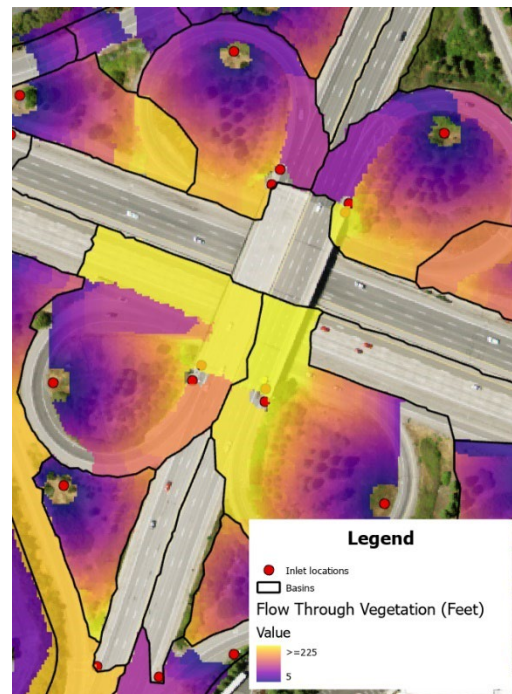

Figure 4: Visualization of Flow Paths through Vegetation



4.4 Compliance Scenarios

There are multiple ways of defining vegetation trash control compliance areas. The following scenarios have been established:

1. Contributing drainage areas flow through a minimum length of vegetation (e.g., concentrated or sheet flow of water passes through at least 5 feet of vegetation in any portion of the flow path). Drainage patterns do not necessarily need to enter an inlet inside or outside of the ROW given infiltration considerations, further justifying trash discharge control.
2. Contributing drainage areas that flow through minimum lengths of vegetation in any portion of the conveyance path and enter into an inlet within Caltrans ROW. Flow can drain outside of Caltrans ROW and back inside of a Caltrans ROW boundary.
3. Contributing drainage areas that drain through a minimum length of vegetation, drain into an inlet, and the flow path never exits Caltrans ROW boundary.
4. Contributing drainage areas that are conveyed through a minimum length of vegetation immediately preceding the field inlet (i.e., the inlet itself is located within a vegetated area).

Criteria 1 contains all areas in criteria 2, criteria 2 contains all areas in criteria 3, and criteria 3 contains all areas in criteria 4. Figure 6 and Figure 7 below show example flow paths that pass through significant vegetation and meet the criteria listed above. The ROW boundary is shown in black and flow paths are approximately drawn in for visualization purposes only.



Figure 5: Visualization of example criteria described in section 4.4.



4.4.1 Vegetation Characteristics

The type, density, and seasonal characteristics of vegetation vary throughout the ROW, and may subsequently influence trash control. In response, vegetated areas will be reviewed to verify a minimum of 70% vegetation coverage and a minimum of 5 feet of vegetation surrounding inlets receiving sheet-flow.

4.4.2 Engineering Controls

As a result of a June 29th, 2023 field visit with San Francisco Regional Board, it was determined that engineering controls will be required at discharge inlet points to increase confidence in meeting full trash capture equivalency when vegetation or roadside features are below the 70% density threshold or when concentrated flow paths may compromise the ability of vegetation to fully control trash.



Figure 7: Engineering Controls at Field Inlets

4.4.2.1 Adaptive Management

The drainage inlet discharge point engineering control used to augment the benefits of vegetation in controlling the discharge of trash. As experience is gained and lessons are learned from annual inspections, modifications to



engineering controls may be required. As a result, Caltrans plans to adaptively manage its efforts to maintain an efficient, effective, and defensible approach to claiming vegetation control credit.

5.0 Correlating Maintenance Effort

The Division of Maintenance protects the public safety and preserves California's highways by maintaining and repairing the system. The Maintenance team responds to emergencies, so travelers and goods reach their destination safely and efficiently. Caltrans removes litter, debris, and sediment to help maintain traffic safety (for both motorized and non-motorized travelers and workers), protect water quality, maintain adequate drainage, and provide an attractive facility for travelers and local communities. This section highlights the thankless work that Caltrans and our contracted crews perform every day in the high-speed freeway environment to pick up trash irresponsibly left by others.

Caltrans Integrated Maintenance Management System (IMMS) is a database used to record and manage maintenance work. IMMS, used as an asset management tool, allows supervisors and managers to track effort across the various litter collection activities. IMMS allows Caltrans to track litter collection expenditures and production through work orders for the various maintenance measures activities that contribute toward trash discharge compliance objectives.

Caltrans commits to removing trash from areas submitted for Vegetation Compliance Credit annually before the rainy season to preclude the possibility of trash degradation. The following maintenance activities will be tracked and reported in the annual report to demonstrate that Caltrans has fulfilled the trash removal obligation.

- Boots on Ground Litter Collection (IMMS Activity D40051 & D40151)
 - Caltrans & Contracted Forces
- Encampment Related Litter Collection (IMMS Activity D42051 / D42050)
- Encampment Removal (Tracked Separately)
- Adopt-A-Highway Volunteerism (IMMS Activity D41050 / D41051)

5.0 Quality Control / Quality Assurance

To ensure consistency of model outputs, multiple QA/QC measures will be implemented. Verifications steps include:

1. Confirmation that treatment sheds were correctly delineated.



Statewide Stormwater Permit & Region 2 Cease & Desist Order

2. Verification of hydraulic connections to confirm the flow of water is conveyed through vegetation immediately preceding the inlet.
3. Identification and removal of overlaps with areas already treated by FTCDs installed on Caltrans ROW or installed in municipal ROW that treat portions of Caltrans ROW.
4. Field Verification for 10% of the qualifying compliance areas.
5. Annual inspection where engineering controls are placed to determine effectiveness.

Once the above steps are completed, the finalized drainage area delineations will be mapped in a GIS database.

California Department of Transportation
Division of Environmental Analysis
Stormwater Management Program
1120 N Street, Sacramento, California 95814

