

CALIFORNIA REGIONAL WATER QUALITY CONTROL BOARD  
CENTRAL VALLEY REGION

Fresno Office  
1685 "E" St.  
Fresno, CA 93706-2007

Sacramento Office (Main)  
11020 Sun Center Dr. #200  
Rancho Cordova, CA  
95670-6114

Redding Office  
364 Knollcrest Dr. #205  
Redding, CA 96002

[Regional Board Website](https://www.waterboards.ca.gov/centralvalley) (https://www.waterboards.ca.gov/centralvalley)

---

**WASTE DISCHARGE REQUIREMENTS ORDER R5-2024-0043**

---



**ORDER INFORMATION**

<b>Order Type(s):</b>	Waste Discharge Requirements (WDRs)
<b>Status:</b>	Adopted
<b>Program:</b>	Non-15
<b>Region 5 Office:</b>	Fresno
<b>Discharger(s):</b>	Sandridge Partners, L.P.
<b>Facility:</b>	Sandridge Cattle Lemoore Processing Facility
<b>Address:</b>	19668 Jackson Avenue
<b>County:</b>	Kings County
<b>Parcel Nos.:</b>	Facility APN 024-080-020 (See Information Sheet, Table 2 for full list of APNs)
<b>CIWQS Place ID:</b>	880629
<b>Prior Order(s):</b>	(none)

## **CERTIFICATION**

I, PATRICK PULUPA, Executive Officer, hereby certify that the following is a full, true, and correct copy of the order adopted by the California Regional Water Quality Control Board, Central Valley Region, on 23 August 2024.

---

PATRICK PULUPA,  
Executive Officer

**TABLE OF CONTENTS**

**TABLE INDEX ..... iii**

**GLOSSARY ..... iv**

**FINDINGS ..... 1**

    Introduction ..... 1

    Background ..... 2

    Proposed Beef Processing Facility ..... 2

        Estimated Wastewater Generation and Proposed Treatment ..... 3

        Proposed Lined Effluent Storage Ponds ..... 5

        Estimated Wastewater Quality and Nutrient Loadings ..... 6

    Site-Specific Conditions ..... 7

        Topography, Climate, and Land Use ..... 7

        Groundwater and Subsurface Conditions ..... 9

    Statutory Authority ..... 11

    Basin Plan Implementation ..... 12

        Beneficial Uses of Water ..... 12

        Water Quality Objectives ..... 13

        Salt and Nitrate Control Programs ..... 14

    Special Considerations for High Strength Waste ..... 15

    Antidegradation Policy ..... 16

    California Environmental Quality Act ..... 20

    Other Regulatory Considerations ..... 20

        Water Code Section 13149.2 ..... 20

        Human Right to Water ..... 21

        Threat-Complexity Rating ..... 22

        Title 27 Exemption ..... 22

        Stormwater ..... 22

    Scope of Order ..... 22

**Table of Contents**

Procedural Matters.....	23
<b>REQUIREMENTS .....</b>	<b>23</b>
A. Standard Provisions .....	23
B. Discharge Prohibitions.....	23
C. Flow Limitation.....	24
D. Salinity Limit .....	24
E. Discharge Specifications .....	24
F. Land Application Area Specifications .....	27
G. Groundwater Limitations.....	28
H. Solids Disposal Specifications.....	29
I. Provisions.....	29
<b>ENFORCEMENT .....</b>	<b>33</b>
<b>ADMINISTRATIVE REVIEW.....</b>	<b>33</b>
<b>ATTACHMENT A — PROJECT LOCATION MAP.....</b>	<b>A-1</b>
<b>ATTACHMENT B – SITE PARCEL AND VICINITY MAP .....</b>	<b>B-1</b>
<b>ATTACHMENT C – PROPOSED PROCESS WATER FLOW DIAGRAM .....</b>	<b>C-1</b>
<b>ATTACHMENT D — REQUIREMENTS FOR MONITORING WELL INSTALLATION     WORKPLANS AND INSTALLATION REPORTS .....</b>	<b>D-1</b>
<b>INFORMATION SHEET .....</b>	<b>IS-1</b>



**TABLE INDEX**

Table 1 — Estimated Wastewater Discharge Volumes.....	4
Table 2 — Proposed Effluent Storage Pond Dimensions.....	5
Table 3 — Anticipated Pond No. 2 Effluent Quality.....	6
Table 4 — LAA-01 Individual Fields .....	6
Table 5 — Estimated Annual Nitrogen/Salt Loading .....	7
Table 6 — Nutrient Uptake Rates .....	7
Table 7 — Source Water Quality.....	9
Table 8 — GAMA Regional Groundwater - Nitrate as Nitrogen Results.....	10
Table 9 — Water Quality Portal Regional Groundwater Quality Results.....	11
Table 10 — Constituents with Potential for Degradation.....	17

## **GLOSSARY**

ALR .....	Action Leakage Rate
Antidegradation Policy.....	Statement of Policy with Respect to Maintaining High Quality Waters in California, State Water Board Resolution 68-16
Basin Plan .....	Water Quality Control Plan for Tulare Lake Basin
bgs .....	Below Ground Surface
BOD <sub>[5]</sub> .....	[Five-Day] Biochemical Oxygen Demand at 20°Celsius
BPTC.....	Best Practicable Treatment and Control
CEQA.....	California Environmental Quality Act, Public Resources Code section 21000 et seq.
CEQA Guidelines .....	California Code of Regulations, Title 14, section 15000 et seq.
COC[s] .....	Constituent[s] of Concern
DO.....	Dissolved Oxygen
DWR.....	California Department of Water Resources
EC .....	Electrical Conductivity
FDS .....	Fixed Dissolved Solids
FEMA .....	Federal Emergency Management Agency
gpd .....	Gallons per Day
HDPE .....	High Density Polyethylene
LAA .....	Land Application Area
lbs/ac/day .....	Pounds per Acre per Day
lbs/ac/yr.....	Pounds per Acre per Year
LCRS.....	Leachate Collection Recovery System
µg/L .....	Micrograms per Liter

**Glossary**

µmhos/cm.....	Micromhos per Centimeter
mgd .....	Million Gallons per Day
mgy .....	Million Gallons per Year
mg/L .....	Milligrams per Liter
msl.....	Mean Sea Level
MRP .....	Monitoring and Reporting Program
MCL.....	Maximum Contaminant Level per Title 22
N.....	Nitrogen
NCP.....	Nitrogen Control Plan
ND .....	Non-Detect
P & O Study .....	Salinity Prioritization and Optimization Study
RWD.....	Report of Waste Discharge
SCP.....	Salt Control Plan
SPRRs .....	Standard Provisions and Reporting Requirements
TDS .....	Total Dissolved Solids
Title 22 .....	California Code of Regulations, Title 22
Title 23 .....	California Code of Regulations, Title 23
Title 27 .....	California Code of Regulations, Title 27
TKN.....	Total Kjeldahl Nitrogen
USEPA.....	United States Environmental Protection Agency
VOC[s].....	Volatile Organic Compound[s]
WDRs.....	Waste Discharge Requirements
WQO[s] .....	Water Quality Objective[s]

## FINDINGS

The Central Valley Regional Water Quality Control Board (Central Valley Water Board) hereby finds as follows:

### Introduction

1. Sandridge Partners, L.P. (Sandridge or Discharger), a California limited partnership, submitted a 17 May 2023 Technical Report of Waste Discharge (May 2023 RWD) proposing to construct a cattle processing facility (referred to as the Sandridge Cattle Lemoore Processing Facility or Facility) at 19668 Jackson Avenue, just southwest of the City of Lemoore in Kings County as depicted on the Project Location Map in **Attachment A**.
2. The Facility will produce processed beef for sale to consumers. When operational, the Facility proposes to harvest up to 210 cattle per day and operate five days per week or 255 days per year. The Facility will be comprised of seven assessor parcels, owned by Sandridge, totaling over 1,225 acres as shown on the Site Parcel and Vicinity Map in **Attachment B**.
3. The approximate location of the proposed Facility, the proposed Land Application Areas, and the adjacent properties are depicted on both **Attachments A and B**. The Facility will comprise about 23 acres of the 284-acre Assessor Parcel Number (APN) 024-080-020 and will be in Section 20, Township 19 South, Range 20 East, Mount Diablo Base and Meridian (MDB&M).
4. The primary land application area (LAA-01) is comprised of APNs 024-040-007 and 024-051-026 which contain about 415 acres of land, of which 369-acres are estimated to be used for the application of wastewater generated from the Facility. LAA-01 is in portions of Section 16 and 17, Township 19 South, Range 20 East, MDB&M. The secondary LAA (LAA-02) is comprised of APN 024-040-006 which contains 412 acres of farmland.
5. Sandridge Partners, L.P., as owner of the land and operator of the proposed Facility, is responsible for compliance with the WDRs prescribed herein.
6. The following materials are attached and incorporated as part of this Order:
  - a. Attachment A — Project Location Map
  - b. Attachment B — Site Parcel and Vicinity Map
  - c. Attachment C — Process Flow Diagram
  - d. Attachment D — Requirements for Monitoring Well Installation Workplans and Monitoring Well Installation Reports

- e. Standard Provisions & Reporting Requirements dated 1 March 1991 (SPRRs)
  - f. Information Sheet
7. Also attached is **Monitoring and Reporting Program Order R5-2024-0043** (MRP), which requires monitoring and reporting for discharges regulated under these WDRs. The Discharger shall comply with the MRP and subsequent revisions thereto as ordered by the Executive Officer or adopted by the Central Valley Water Board.
8. WDRs are needed for this Facility to ensure the discharge meets the requirements of current water quality plans and policies.

### **Background**

9. Central Valley Regional Water Quality Control Board (Central Valley Water Board) staff (Staff) received a Conditional Use Application (CUP) 21-06 from Kings County, Community Development Agency, Planning Division on 21 December 2021 for a new cattle feedlot and beef processing facility. Central Valley Water Board staff responded in an 18 January 2022 letter commenting on the proposed CUP. On 15 March 2022, Kings County issued a Project Review Consultation Notice that proposed to construct and operate a beef harvesting plant on approximately 135 acres. The formerly proposed feedlot was removed from consideration and the 15 March 2022 Project Review Consultation Notice evaluated only a proposed beef processing facility.
10. Since the issuance of the 15 March 2022 Project Review Consultation Notice by Kings County, Central Valley Water Board staff have received several technical reports and evaluations. These documents included the submittal of an initial Report of Waste Discharge (RWD) in April 2022 (and subsequent revised RWDs, including an October 2022 RWD and May 2023 RWD) and a February 2023 Monitoring Well and Pond Liner Work Plan (and subsequent revised work plans, including a May 2023 Revised Work Plan). See the Information Sheet included in this Order for more details of these reports and Central Valley Water Board staff's responses to the submittals.

### **Proposed Beef Processing Facility**

11. **Attachment C** depicts a wastewater flow plan for the Facility. The proposed beef processing Facility will include the following:
- 75,000 square feet of building space that will include livestock loading and holding areas, a kill and processing floor, coolers, cold storage, dry storage, a cut room, offices, employee facilities, and 1,900 square feet of retail space (The Facility will produce processed beef for sale to consumers).

- A 7,200 square foot concrete pad and shelter for the wastewater treatment system (see Finding 15 for a description of the wastewater treatment facility).
  - A 33,000 square foot, concrete manure stacking pad that will be sloped to a drainage swale that drains to the sand lane.
  - A 700 square foot sand lane. Wastewater will flow down the concrete sand land where solids are settled/filtered from the effluent. The settled solids will be removed from the sand lane and hauled to the manure stacking pad.
  - Two, double-lined effluent storage ponds constructed for effluent/water storage, BOD aeration control, and retention for irrigation. Each pond will be equipped with aerators. Per the May 2023 Pond Liner Report, the storage capacity of each pond will be about 1.9 million gallons, with a combined capacity of about 3.8 million gallons.
12. Effluent will be used as a supplemental source of irrigation water to grow crops using flood irrigation on an approximately 369-acre land application area (LAA-01). An additional 400 acres are available as a reserve land application area (LAA-02) if needed.

#### Estimated Wastewater Generation and Proposed Treatment

13. Wastewater will be generated at the proposed Facility from three general areas: (1) the holding pens, (2) the beef processing and cutting area, and (3) the slaughter floor. Wastewater will be routed to area drains with screens to remove hair and solids. Wastewater generated from the holding pens will be treated to remove solids using a sand lane, while wastewater generated at the slaughter floor and the beef cutting and production area will be routed through a wastewater treatment system described in Finding 15. All blood generated at the slaughter floor is collected via area drains and routed into two-refrigerated holding tanks and processed by an offsite vendor. A flow schematic is presented in **Attachment C**.
14. Cattle will be brought to the Facility by truck and kept in concrete lined holding pens prior to processing. Wastewater generated from the holding pens will include cow urine, water spillage, and cattle and pen washdown water. The concrete floors will be sloped to channel wastewater into a drainage swale that flows to a screened area drain. The pens will be rinsed daily and the washdown water/effluent will flow to the area drains, then pumped into a concrete sand lane, which will allow solids to settle out, and then the effluent will gravity flow via pipeline to the first of two double lined effluent storage ponds (Pond No. 1) equipped with aerators. Wastewater will then flow into Pond No. 2, also equipped with aerators to assist in controlling odors, where it will be stored for eventual use as a supplemental source of irrigation for the crops grown in the LAAs. The solids that settle out in the sand lane will be hauled to the onsite manure stacking pad. As shown in Table 1, wastewater treated using the sand lane and discharged from

the holding pens will comprise about two percent of the total estimated daily flow into Pond No. 1.

15. The primary waste stream generated at the Facility will be the from the beef cutting and processing area and the slaughter floor. This waste stream produces over 95 percent of the wastewater generated at the facility and is primarily wash water from disinfecting the processing equipment and cutting floor. The wastewater treatment system will consist of the following as described in the May 2023 RWD:

- Rotary drum screen
- Aerated equalization tank
- pH adjustment
- Flocculation
- Dissolved air floatation

16. The Discharger estimated the annual volumes of wastewater that will be generated by each of the three process wastewater sources as shown in Table 1.

**Table 1 — Estimated Wastewater Discharge Volumes**

Area	Treatment	Cattle (per day)	Daily Flow (gpd)	Annual Flow (mgy)
Holding Pens	Sand Lane	300	1,125	0.29
Cutting-Processing/ Slaughter Floor	Treatment System	210	52,500	13.65
	<b>Totals</b>	<b>510</b>	<b>53,625</b>	<b>13.94</b>

17. The rotary drum screen is described in the May 2023 RWD as: *“The internally fed rotary screen will consist of a cylindrical wedge wire screen, influent headbox for flow distribution, external spray bar, mechanical rotation system, and a chain drive and gearmotor.”* From the rotary drum screen, the wastewater will be discharged into an equalization tank that allows for equalization of contaminants, aeration, and delivers a constant flow of wastewater to the flocculator. The treatment process will use sodium hydroxide and sulfuric acid to adjust the pH of the wastewater and Coagulant 185 and Floc 265 to increase coagulation and flocculation. Once the treated water enters Pond No. 1, it will be further aerated to reduce the BOD concentrations in the wastewater prior to land application. Solids generated during the treatment processes will be deposited onto the manure stacking pad.

18. Wastewater generated at the slaughter floor will contain a composition of fats, fibers, organic content, and pathogens. Blood will be collected in holding tanks in a refrigerated area and picked up by a licensed rendering company and taken offsite. Washdown water flows into floor drains with screens to remove solids. The solids will be routed to a holding tank and the wastewater to an influent sump prior to treatment. Solids in the holding tank will be picked up by Baker Commodities for processing at their rendering site.

**Proposed Lined Effluent Storage Ponds**

19. Sandridge is proposing to construct two double-lined high-density polyethylene (HDPE) effluent storage ponds (Ponds No. 1 and No. 2) with leachate collection and removal systems (LCRS) installed between the two liners. The pond specifications, Construction Quality Assurance (CQA) Plan, and a Pond Operation and Maintenance Plan were included in the May 2023 Pond Liner Report.
20. The capacity of each pond was estimated to be about 1.9 million gallons with two feet of freeboard, and a combined capacity of about 3.8 million gallons. Due to shallow perched groundwater detected as high as 5.5 feet bgs, the May 2023 Pond Liner Report proposed the ponds be constructed with the base entirely above the existing grade. Each pond will be equipped with a dewatering system that will be set about three feet below the base of the pond liner system to pump groundwater should it rise to within three feet of the ground surface. The proposed dimensions of the pond and the estimated capacities are shown in Table 2.

**Table 2 — Proposed Effluent Storage Pond Dimensions**

<b>Pond ID</b>	<b>Length (feet)</b>	<b>Width (feet)</b>	<b>Depth (feet)</b>
1	250	250	7.7
2	250	250	7.7

21. The effluent storage ponds (Ponds No.1 and No. 2) will have a LCRS installed between the double liner system that are equipped with pan lysimeters to monitor for potential leakage. An 8-inch diameter high density polyethylene (HDPE) pipe will be installed from the LRCS to the top of the pond at the anchor trench to allow for leaks to be detected and for the leachate to be pumped from the LCRS. With a coverage of 1.43 acres, the Revised Pond Liner Report indicates the LCRS will have an estimated action leakage rate of 1.9 gallons per minute.
22. Ponds No. 1 and No. 2 will each be equipped with 25 horsepower, motor-driven floating surface aerators to provide additional BOD treatment before effluent is discharged LAAs. Specifically, the Ponds' Operation and Maintenance Plan states that "DO [dissolved oxygen] levels and odor conditions will be maintained on site through a Chemtrac Dissolved Oxygen Monitor and Evoqua Aqua-Lator Surface



Aerator.” The RWD indicates one Evoqua surface aerator will provide oxygen dispersion up to 10 feet in depth and 295 feet in diameter.

Estimated Wastewater Quality and Nutrient Loadings

23. The Discharger provided an estimate of the quality of the beef processing wastewater stored in effluent Pond No. 2 prior to discharge to the LAAs using data from other similar sites (EPA, 2004). The estimated wastewater concentrations are presented below in Table 3.

**Table 3 — Anticipated Pond No. 2 Effluent Quality**

Constituent	Units	Anticipated Effluent Quality
EC	µmhos/cm	3,273
TDS	mg/L	2,600
FDS	mg/L	1,950
Total Nitrogen	mg/L	240
Ammonia (as N)	mg/L	209
Chloride	mg/L	110
Sodium	mg/L	190
BOD	mg/L	450

24. A Nutrient Management Plan was included as Appendix P of the May 2023 RWD. The Nutrient Management Plan was prepared by Louis R. Oliveira, Certified Crop Advisor #17275. The Nutrient Management Plan divides the 369-acre LAA-01 into four separate fields as follows.

**Table 4 — LAA-01 Individual Fields**

<u>Field ID</u>	<u>Acres</u>	<u>APN</u>
HM16SW (Field 1)	145	024-051-026
HM17S West (Field 2)	85	024-040-007
HM17S East (Field 3)	85	024-040-007
HM16NW (Field 4)	54	024-051-026
<b>Totals</b>	<b>369</b>	

25. Loading scenarios were presented in the RWD for the individual fields. The estimated BOD loadings are less than one pound per acre per day. Salt loadings are based on estimated TDS results. The Nutrient Management Plan estimates the nitrogen load from the proposed Sandridge discharge will comprise between 13 and 21 percent of the total nitrogen loading with the majority of the nitrogen

loading coming from manure, and liquid and dry fertilizer applications. Table 5 presents the nutrient and salt loading from all sources (wastewaters, irrigation water, fertilizers, etc.) for the individual fields of LAA-01.

**Table 5 — Estimated Annual Nitrogen/Salt Loading**

<b>Fields</b>	<b>Nitrogen (lbs/ac/yr)</b>	<b>Potassium (lbs/ac/yr)</b>	<b>Phosphorus (lbs/ac/yr)</b>	<b>TDS (lbs/ac/yr)</b>
Field 1 - Wheat	217	64	201	223
Field 1 – Silage Corn	327	107	426	445
Field 2 - Wheat	217	64	201	223
Field 2 – Silage Corn	310	105	446	445
Field 3 – Wheat	217	64	201	223
Field 3 - Sorghum	231	71	311	334
Field 4 – Wheat	217	64	201	223
Field 4 - Sorghum	228	52	332	334

26. The Western Fertilizer Handbook (8<sup>th</sup> Edition) includes nitrogen, potassium, phosphorus uptake rates for wheat silage corn, and sorghum as shown below in Table 6.

**Table 6 — Nutrient Uptake Rates**

<b>Plant</b>	<b>Nitrogen (lbs/ac)</b>	<b>Potassium (lbs/ac)</b>	<b>Phosphorus (lbs/ac)</b>
Wheat	175	200	70
Silage Corn	250	250	105
Sorghum	325	475	325

**Site-Specific Conditions**

Topography, Climate, and Land Use

27. The Facility and LAAs will be set at an elevation of about 210 feet above mean sea level and the natural land surface slopes very gradually to the west/southwest. The nearest natural surface water is the Kings River which is about 1.9 miles west of the proposed Facility and about 1.25 miles west of the western edge of LAA-01.
28. According to the Web Soil Survey published by the United States Department of Agriculture, Natural Resources Conservation Service, soils in the area of the Facility consists primarily of the Lemoore sandy loam (~58%) with lesser amounts of Grangeville sandy loam, saline-alkali (~19%), Goldberg loam (~13%), and

Lakeside loam (~10%) being present to the north of the Facility. The Land Capability Classification indicates the Lemoore sandy loam is a Class 2w soil that has moderate limitations that reduce the choice of plants or that require moderate conservation practices. The “w” subclass indicates that water in or on the soil may interfere with plant growth or cultivation.

29. Soils in the area of the land application areas LAA-01 and LAA-02 consists primarily of the Lakeside loam (~38%) and the Lemoore sandy loam (~28%) with lesser amounts of Goldberg loam (~20%) and Grangeville sandy loam, saline-alkali (~12%). The Land Capability Classification indicates the Lakeside loam is also a Class 2w soil that has moderate limitations that reduce the choice of plants or that require moderate conservation practices and that water in or on the soil may interfere with plant growth or cultivation.
30. The Facility and LAAs are in an arid climate characterized by dry summers and mild winters. The rainy season generally extends from October to April. The average annual precipitation in the area is about 8.38 inches, according to the Western Regional Climate Center. Average annual pan evaporation in the area is about 80.6 inches, according to the National Oceanic and Atmospheric Administration Technical Report NWS 34, Mean Monthly, Seasonal, and Annual Pan Evaporation for the United States, published by the U.S. Department of Commerce, National Oceanic and Atmospheric Administration.
31. The Facility and the land application areas are primarily within Federal Emergency Management Agency (FEMA) flood map 06031C0165D with the eastern edge of the subject properties within FEMA flood map 06031C0170D. According to the flood map, the Facility and LAA-1 are not within a 100-year flood zone special hazards area. The western portion of the reserve land application area (LAA-02) is within a Zone A Special Flood Hazards Area indicating the potential flood depth of 1 foot. The extent of the estimated flooding is controlled by a berm along Highway 198, which bisects the land application areas and limits the potential for flood waters to spread to the east/southeast across the subject property to the Facility.
32. Land usage surrounding the Facility is primarily agricultural to the south, west, and northwest with some commercial/light industrial present to the east and across Highway 41, including the Kings Speedway and the Surf Ranch businesses. The subject property is bounded to the east by Highway 41. Highway 198 traverses between LAA-01 and LAA-02. Suburban residential units of the City of Lemoore are about 0.5 miles northeast of the northeastern corner of LAA-02. The Lemoore campus of the West Hills Community College is about 1,600 feet north of the northern edge of LAA-02. According to the California Department of Water Resources Land Use Viewer, typical crops grown in the area include deciduous fruits, nuts, grapes, pasture, and field crops.

Groundwater and Subsurface Conditions

33. Groundwater is present in perched zones that overlie deeper aquifers. Source water is supplied to the Facility by three onsite wells. Construction information (depth of well, screened interval, seals) was not provided, but results from a one-time sampling event from August 2021 are presented in Table 7.

**Table 7 — Source Water Quality**

Constituent	Units	Well 1	Well 2	Well 3
pH	s.u.	7.53	7.65	8.6
EC	µmhos/cm	629	2,930	935
TDS	mg/L	450	8,510	600
Nitrate as N	mg/L	ND	ND	ND
Chloride	mg/L	32	880	54
Hardness as Calcium Carbonate	mg/L	18.2	805	33
Iron	µg/L	1,320	2,400	1,680
Aluminum	µg/L	1,000	500	1,200
Lead	µg/L	31	15	11
Barium	µg/L	33	27	38

Onsite Groundwater Occurrence

34. There is currently no groundwater monitoring well network present on the subject property. Monitoring wells are to be installed in the vicinity of the Facility and the land application areas. Sandridge has, however, conducted several geotechnical investigations on the subject property that encountered shallow perched groundwater. BSK Labs advanced 11 soil borings and excavated 6 percolation test pits in September 2021 to depths ranging from about 3 to 21 feet bgs, and groundwater was encountered from 5 to 19 feet bgs.
35. None of the 2021 borings were advanced in the area of the proposed effluent storage ponds. Following discussions with Central Valley Water Board staff, Sandridge had BSK advance five additional soil borings in the area of the proposed ponds in March 2023. Two soil borings were drilled at the northeast and southeast corner of proposed Pond No. 1, two were drilled at the northwest and southwest corners of proposed Pond No. 2, and one boring was drilled between the two ponds in a central location. The depth to water encountered during the March 2023 investigation in the area of the proposed effluent storage ponds ranged from 5.5 to 8 feet bgs.

Regional Groundwater Occurrence and Quality

36. Regional depth to groundwater information and groundwater elevation maps are available on the [California Department of Water Resources \(DWR\) SGMA Data Viewer](https://sgma.water.ca.gov/webgis/?appid=SGMADataViewer) (https://sgma.water.ca.gov/webgis/?appid=SGMADataViewer). Groundwater elevations for spring 2022 indicate that the predominant groundwater flow direction is to the northwest near the location of the Facility and the depth to groundwater was shown at about 200 feet bgs, with a corresponding groundwater elevation of about 15 feet above msl. It should be noted that the groundwater elevations and direction of groundwater flow used in the DWR SGMA Data Viewer maps are derived from wells set in the deeper aquifers and are not reflective of the perched groundwater that is present as shallow as 5 feet bgs around the proposed Facility.
37. Staff reviewed the GAMA Groundwater Information System and identified nine wells (five downgradient and four upgradient) in the vicinity of the proposed Facility with analytical results for nitrate as nitrogen. The results are summarized in Table 8 below and are highly variable with results ranging from non-detect in samples from five of the wells to exceeding the Primary MCL of 10 mg/L in the other four wells.

**Table 8 — GAMA Regional Groundwater - Nitrate as Nitrogen Results**

Well Numbers	Date	Screened Interval (feet bgs)	Gradient Position	Nitrate as N (mg/L)
AGW1080011462	11/7/2019	---	Downgradient	0.4 (ND)
AGW1080011462	5/24/2021	---	Downgradient	0.4 (ND)
AGW1080011462	5/17/2022	---	Downgradient	0.4 (ND)
NO3-1027557	8/9/1990	3.6 – 16.4	Downgradient	12.9
NO3-1027559	8/9/1990	42.5 – 47.5	Downgradient	0.08 (ND)
NO3-1027558	8/30/1990	26 - 60	Downgradient	0.08 (ND)
NO3-1027496	12/5/1984	---	Downgradient	20.9
NO3-1002355	7/23/2001	---	Upgradient	0.1 (ND)
NO3-1002356	7/23/2001	618 - 778	Upgradient	0.1 (ND)
NO3-1002378	11/1/2007	---	Upgradient	10.7
NO3-1002378	4/1/2009	---	Upgradient	11.4
NO3-1002379	11/1/2007	---	Upgradient	17.4
NO3-1002379	8/11/08	---	Upgradient	16.8
NO3-1002379	8/11/08	---	Upgradient	17.1

38. Staff reviewed the National Water Quality Monitoring Council’s Water Quality Portal and identified ten wells within a two-mile radius of the Facility. Regional groundwater analytical results dating from 1960 to 1990 are shown in Table 9. Similar to the water quality results presented in Table 8, the results exhibit a wide range of variability with concentrations both lower than and higher than the applicable water quality objective.

**Table 9 — Water Quality Portal Regional Groundwater Quality Results**

Well Numbers (See 1 below)	Date	Nitrate as N (mg/L)	EC (µmhos/cm)	TDS (mg/L)	Chloride (mg/L)	Sulfate (mg/L)	Well Depth (feet)
USGS 001	6/7/89	0.6	750	502	45	230	16.5
USGS 301	7/25/60	3.6	537	337	29	0	525
USGS 301	8/13/86	0.1	524	na	30	10	525
USGS 401	6/1/89	4.1	40,500	47,000	3,700	28,000	11.7
USGS 401	12/6/84	2.4	49,200	50,400	4,200	29,000	11.7
USGS 601	9/17/68	0.2	1,030	630	66	2	1,309
USGS 701	8/9/90	12.9	21,500	---	840	12,000	20
USGS 702	8/30/90	---	41,700	---	2,000	29,000	60
USGS 703	8/9/90	12.7	39,200	---	1,800	29,000	90
USGS 704	8/30/90	---	15,200	---	980	7,700	200
USGS 801	5/11/62	2.1	2,300	1,750	200	660	20
USGS 801	7/18/68	1.3	1,100	696	67	75	20
USGS 901	5/31/89	15	1,300	810	59	160	14.1
<b>Water Quality Objective</b>	---	<b>10.0</b>	<b>900/ 1600/ 2200</b>	<b>500/ 1000/ 1500</b>	<b>250/ 500/ 600</b>	<b>250/ 500/ 600</b>	---

1. Well numbers were abbreviated above. Well numbers are USGS-361415119500001, USGS-361424119475301, USGS-361425119485401, USGS-361452119513601, USGS-361455119495701, USGS-361455119495702, USGS-361455119495703, USGS-361455119495704, and USGS-361457119511801.

**Statutory Authority**

39. This Order is adopted pursuant to Water Code section 13263, subdivision (a), which provides, in pertinent part, as follows:

*The regional board, after any necessary hearing, shall prescribe requirements as to the nature of any proposed discharge, existing*

*discharge, or material change in an existing discharge..., with relation to the conditions existing in the disposal area or receiving waters upon, or into which, the discharge is made or proposed.*

40. Compliance with section 13263, subdivision (a), including implementation of applicable water quality control plans, is discussed in the findings below.
41. The ability to discharge waste is a privilege, not a right, and adoption of this Order shall not be construed as creating a vested right to continue discharging waste. (Wat. Code, § 13263, subd. (g).)
42. This Order and its associated Monitoring and Reporting Program (MRP) are also adopted pursuant to Water Code section 13267, subdivision (b)(1), which provides as follows:

*[T]he regional board may require that any person who has discharged, discharges, or is suspected of having discharged or discharging, or who proposes to discharge waste ... shall furnish, under penalty of perjury, technical or monitoring program reports which the regional board requires. The burden, including costs, of these reports shall bear a reasonable relationship to the need for the report and the benefits to be obtained from the reports. In requiring those reports, the regional board shall provide the person with a written explanation with regard to the need for the reports and shall identify the evidence that supports requiring that person to provide the reports.*

43. The reports required under this Order, as well as under the separately issued MRP Order, are necessary to verify and ensure compliance with WDRs. The burden associated with such reports is reasonable relative to the need for their submission.

### **Basin Plan Implementation**

44. Pursuant to Water Code section 13263, subdivision (a), WDRs must “implement any relevant water quality control plans... and shall take into consideration the beneficial uses to be protected, the water quality objectives reasonably required for that purpose, other waste discharges, the need to prevent nuisance, and the provisions of Section 13241.”

### **Beneficial Uses of Water**

45. This Order implements the Central Valley Water Board’s Water Quality Control Plan for the Tulare Lake Basin (Basin Plan), which designates beneficial uses for surface water and groundwater and establishes water quality objectives (WQOs) necessary to preserve such beneficial uses. (See Wat. Code, § 13241 et seq.).

46. The Kings River is about 1.25 miles west of the proposed LAA-01 and about 1.9 miles west of the proposed Facility. Per the Basin Plan, the existing beneficial uses of Kings River from Peoples Wier to the Empire Wier No. 2 on the South Fork of the Kings River include irrigation and stock watering (AGR), water contact recreation (REC-1), other non-contact water recreation (REC-2), warm freshwater habitat (WARM), wildlife habitat (WILD), and groundwater recharge (GWR).
47. The Facility is in the South Valley Floor hydrologic unit, Hanford-Lemoore hydrologic area. Per the Basin Plan, beneficial uses of underlying groundwater at the Facility are municipal and domestic supply (MUN), agricultural supply (AGR), industrial service supply (IND), and industrial process supply (PRO).

#### Water Quality Objectives

48. The numeric WQO for bacteria is expressed as the most probable number (MPN) of coliform organisms per 100 mL of water. For MUN-designated groundwater, the objective is an MPN of 2.2 organisms over any seven-day period.
49. The narrative WQO for chemical constituents in groundwater generally provides that groundwater shall not contain constituents in concentrations adversely affecting beneficial uses. For MUN-designated waters, the Basin Plan further provides that such water shall, at a minimum, meet the primary and secondary maximum contaminant levels (MCLs) specified in California Code of Regulations, title 22 (Title 22)<sup>1</sup> (See Title 22, §§ 64431, 64444, 64449).
50. The narrative WQO for toxicity provides that groundwater shall be maintained free of toxic substances in concentrations producing detrimental physiological responses in human, animal, plant, or aquatic life associated with designated beneficial uses.
51. To the extent necessary, narrative WQOs are quantified, on a site-specific basis, as numeric limits for constituents with potential to adversely impact designated uses. In determining a site-specific numeric limit, the Central Valley Water Board considers relevant published criteria.
52. In determining a numeric limit for salinity protective of agricultural supply (AGR), the Central Valley Water Board is relying on general salt tolerance guidelines, which indicate that although yield reductions in nearly all crops are not evident when irrigation water has an electrical conductivity (EC) of less than 700  $\mu\text{mhos/cm}$ , there is an eight- to ten-fold range in salt tolerance for agricultural

---

<sup>1</sup> Central Valley Water Board may apply limits more stringent than MCLs to ensure that waters do not contain chemical constituents in concentrations that adversely affect beneficial uses.



crops. (See, e.g., *Ayers & Westcot, Water Quality for Agriculture* [1985], § 2.3.) For this reason, appropriate salinity values are considered on a case-by-case basis. It is possible to achieve full yield potential with groundwater EC up to 3,000 µmhos/cm, if the proper leaching fraction is provided to maintain soil salinity within the tolerance of the crop.

53. The crops listed in Finding 32 are not intended as a definitive inventory of crops that are or could be grown in the area where groundwater quality is potentially affected by the discharge, but it is representative of current and historical agricultural practices in the area.

#### Salt and Nitrate Control Programs

54. The Central Valley Water Board adopted Basin Plan amendments incorporating new programs for addressing ongoing salt and nitrate accumulation in the Central Valley at its 31 May 2018 Board Meeting (Resolution R5-2018-0034). The Basin Plan amendments became effective on 17 January 2020 and were revised by the Central Valley Water Board in 2020 with [Resolution R5-2020-0057](https://www.waterboards.ca.gov/centralvalley/board_decisions/adopted_orders/resolutions/r5-2020-0057_res.pdf) ([https://www.waterboards.ca.gov/centralvalley/board\\_decisions/adopted\\_orders/resolutions/r5-2020-0057\\_res.pdf](https://www.waterboards.ca.gov/centralvalley/board_decisions/adopted_orders/resolutions/r5-2020-0057_res.pdf)).
55. For the Salt Control Program, dischargers that are unable to comply with stringent salinity requirements are instead required to meet performance-based limits and participate in a basin-wide effort known as the Salinity Prioritization and Optimization Study (P&O Study) to develop a long-term salinity strategy for the Central Valley. The Discharger submitted a Notice to Intent to participate in the P&O Study (Alternative Permitting Approach) the Salt Control program on 22 June 2022 (**CV-SALTS: ID 3613**). To minimize salinity impacts, this Order does the following:
- a. Requires the Discharger to submit a Salinity Evaluation and Minimization Plan to evaluate methods to control salinity in its discharge to the extent feasible; and
  - b. Sets an annual Salinity Mass Loading Limit of 250,000 pounds annually of FDS for the discharge of wastewater sent to the LAAs. This limit considers the anticipated FDS concentration of the discharge (1,950 mg/L), the reported projected annual flow (13.94 MG), and a 10% contingency.
56. For the Nitrate Control Program, dischargers of nitrate to groundwater basins or sub-basins may comply with the new nitrate program either individually (Pathway A) or collectively with other dischargers (Pathway B). The Facility is within Groundwater Basin 5-022.12 (San Joaquin Valley – Tulare Lake), which is a Priority 2 Basin. Notices to Comply for Dischargers in Priority 2 Basins were sent to the Discharger in December 2023 and the Discharger has until February 2025

to respond to the notice. The Discharger has indicated they intend to participate in the Pathway B Management Plan for Groundwater Basin 5-022.12.

57. As these strategies are implemented, the Central Valley Water Board may find it necessary to modify the requirements of these WDRs. As such, this Order may be amended or modified to incorporate any newly applicable requirements to ensure that the goals of the Salt and Nitrate Control Programs are met.

### **Special Considerations for High Strength Waste**

58. For the purpose of this Order, "high strength waste" is defined as wastewater that contains concentrations of readily degradable organic matter that exceed typical concentrations for domestic sewage. Such wastes contain greater than 500 mg/L BOD. Typical high strength wastewaters include septage, some food processing wastes (e.g., slaughterhouse wastes), winery wastes, and rendering plant wastes.
59. Excessive application of high organic strength wastewater to land can create objectionable odors, soil conditions that are harmful to crops, and degradation of underlying groundwater with nitrogen species and metals, as discussed below. Such groundwater degradation can be prevented or minimized through implementation of best management practices, which include planting crops to take up nutrients, and maximizing oxidation of BOD to prevent nuisance conditions.
60. Regarding BOD, excessive application can deplete oxygen in the vadose zone and lead to anoxic conditions. At the ground surface, this can result in nuisance odors and fly breeding. When insufficient oxygen is present below the ground surface, anaerobic decay of the organic matter can create reducing conditions that convert metals that are naturally present in the soil as relatively insoluble (oxidized) forms to more soluble reduced forms. This condition can be exacerbated by acidic soil and/or acidic wastewater. If the reducing conditions do not reverse as the percolate travels down through the vadose zone, these dissolved metals (primarily iron, manganese, and arsenic) can degrade shallow groundwater quality. Many aquifers contain enough dissolved oxygen to reverse the process, but excessive BOD loading over extended periods may cause beneficial use impacts associated with these metals.
61. Typically, irrigation with high strength wastewater results in high loading on the day of application. It is reasonable to expect some oxidation of BOD at the ground surface, within the evapotranspiration zone, and below the root zone within the vadose (unsaturated) zone. The maximum BOD loading rate that can be applied to land without creating nuisance conditions or leaching of metals can vary significantly depending on soil conditions and operation of the land application system.

62. *Pollution Abatement in the Fruit and Vegetable Industry*, published by the United States Environmental Protection Agency, cites BOD loading rates in the range of 36 to 600 lbs/acre-day to prevent nuisance, but indicates the loading rates can be even higher under certain conditions. The studies that supported this report did not evaluate actual or potential groundwater degradation associated with those rates. There are few studies that have attempted to determine maximum BOD loading rates for protection of groundwater quality. Those that have been done are not readily adapted to the varying soil, groundwater, and climate conditions that are prevalent throughout the region.
63. The California League of Food Processors' *Manual of Good Practice for Land Application of Food Processing/Rinse Water* (Manual of Good Practice) proposes risk categories associated with particular BOD loading rate ranges as follows:
- a. Risk Category 1: (less than 50 lbs/ac/day; depth to groundwater greater than 5 feet) Indistinguishable from good farming operations with good distribution important.
  - b. Risk Category 2: (less than 100 lbs/ac/day; depth to groundwater greater than 5 feet). Minimal risk of unreasonable groundwater degradation with good distribution more important.
  - c. Risk Category 3: (greater than 100 lbs/ac/day; depth to groundwater greater than 2 feet) Requires detailed planning and good operation with good distribution very important to prevent unreasonable degradation, as well as use of oxygen transfer design equations that consider site-specific application cycles and soil properties and special monitoring.

The Manual of Good Practice recommends allowing a 50 percent increase in the BOD loading rates in cases where sprinkler irrigation is used but recommends that additional safety factors be used for sites with heavy and/or compacted soils.

64. Although it has not been subject to a scientific peer review process, the Manual of Good Practice provides science-based guidance for BOD loading rates that, if fully implemented, are considered a best management practice to prevent groundwater degradation due to reduced metals. Projected BOD loading rates to the LAAs are less than one pound per acre per day, as discussed in Finding 25. These WDRs establish a BOD cycle average loading rate of 50 lbs/ac/day to prevent odor conditions from occurring and to prevent groundwater degradation due to reduced metals.

### **Antidegradation Policy**

65. *The Statement of Policy with Respect to Maintaining High Quality Waters in California*, State Water Resources Control Board Resolution 68-16

(Antidegradation Policy), which is incorporated as part of the Basin Plan, prohibits the Central Valley Water Board from authorizing degradation of “high quality waters” unless it is shown that the discharge(s) causing such degradation will be consistent with the maximum benefit to the people of California, will not unreasonably affect beneficial uses, and will not result in water quality worse than applicable WQOs. Any discharge to high quality waters must meet requirements that will result in the best practicable treatment or control (BPTC)

66. The Antidegradation Policy applies when an activity discharges to high quality waters and will result in some degradation of such high-quality waters. "High quality waters" are defined as those waters where water quality is more than sufficient to support beneficial uses designated in the Basin Plan. Whether a water is a high-quality water is established on a constituent-by-constituent basis, which means that an aquifer can be considered a high-quality water with respect to one constituent, but not for others (SWRCB Order No. WQ 91-10). If the activity will not result in the degradation of high-quality waters, the Antidegradation Policy does not apply, and the dischargers need only demonstrate that it will use "best efforts" to control the discharge of waste.
67. The Discharger submitted a May 2023 Revised Monitoring Well Installation and Sampling Plan (Well Installation Work Plan) that proposes to install up to an eight-well groundwater monitoring network (three groundwater monitoring wells in the vicinity of the Facility and up to five around the two LAAs). No groundwater monitoring wells are currently present at the Facility or the LAAs. Given the limited availability of pre-1968 water quality information, and the variable water quality at different depths, compliance with the Antidegradation Policy will be determined based partly on pre-1968 water quality and site-specific groundwater data, as discussed below. Table 10 compares the proposed effluent quality for constituents of concern with pre-1968 and existing upgradient and downgradient groundwater quality data.

**Table 10 — Constituents with Potential for Degradation**

Constituent	Estimated Effluent Quality	Pre 1968 Groundwater Quality	Upgradient	Downgradient	MCL/ WQOs
BOD (mg/L)	450	---	---	---	---
Nitrate as N (mg/L)	240	0.2 – 3.6	0.1 - 17.4	0.1 - 20.9	10
Total nitrogen (mg/L)	100 to 240	---	---	---	---
EC (µmhos/cm)	3,273	537 - 2,300	524 – 49,200	750 – 41,700	900, 1,600, 2,200

Constituent	Estimated Effluent Quality	Pre 1968 Groundwater Quality	Upgradient	Downgradient	MCL/ WQOs
TDS (mg/L)	2,600	337 – 1,750	337 – 50,400	502 – 1,750	500, 1,000, 1,500
FDS (mg/L)	1,950	---	---	---	---
Chloride (mg/L)	110	29 – 200	29 – 4,200	45 – 2,000	250, 500, 600
Sulfate (mg/L)	---	1 - 660	1 – 29,000	2 – 29,000	250, 500, 600

- a. **Salinity.** The limited available groundwater data for the site shows groundwater quality is highly variable and generally of poor water quality with regards to salinity as shown in Table 9. Shallow groundwater is present in the vicinity of the Facility, lined effluent storage ponds, and the proposed land application areas. Based on available data, the shallow groundwater beneath the Facility and land application area is not considered high-quality water with respect to salinity. These WDRs include various requirements (e.g., participation in the P&O Study, treating the wastewater, storage of wastewater on properly lined surfaces, application at agronomic rates) constitute best efforts to control the discharge of salt from the Facility. The May 2023 RWD estimates the discharge at 0.054 mgd. The estimated annual salt loading is about 620 lbs/ac/year when discharged to the 369-acre LAA-01.
  
- b. **Nitrate.** As with salinity, the available groundwater quality data for the region is variable with respect to nitrate as nitrogen with results ranges from non-detect to 20.9 mg/L, twice the MCL of 10 mg/L. Total nitrogen levels in the proposed discharge were estimated to range from 100 to 240 mg/L and ammonia as nitrogen is estimated to range from 40 to 209 mg/L. Nitrogen loading for the land application areas is estimated to be about 75 lbs/ac/yr. The Discharger indicates additional nitrogen fertilizer will be required to grow the crop. As discussed in the salinity discussion above as well as in previous findings, the Discharger has proposed (and required per these WDRs) to implement various measures to reduce the Facility’s potential impact on underlying groundwater (i.e., lining the Facility’s ponds and application of process wastewater on crops at agronomic rates. Furthermore, the Facility is in a Priority 2 Zone for the Nitrate Control Program. The Discharger received a Notice to Comply for the Nitrate Control Program in December 2023 and has until February 2025 to respond. The Discharger has indicated they plan to participate in the Pathway B Management Plan for Groundwater Basin 5-022.12 for nitrate as discussed in Finding 56.

- c. **Organics.** The Facility produces high-strength process wastewater, with BOD concentrations estimated in the influent to range from 2,500 to 3,870 mg/L. Storage of high-strength process wastewater to unlined ponds or over application to land application areas can result in reducing conditions resulting in certain metals (primarily iron, manganese, and/or arsenic) converting to more soluble reduced forms. To address these concerns, in part, the WDRs require the Discharger to install double lined effluent storage ponds and comply with a BOD cycle average loading rate of no more than 50 lbs/acre/day. BOD loading estimates are low and the estimated annual average is 0.29 lbs/ac/day due to having 369-acres in LAA-01.
68. The Discharger implements, or will implement, as required by this Order the following measures, which the Central Valley Water Board has determined constitutes BPTC. These measures will minimize the extent of water quality degradation resulting from the Facility's discharges:
  - a. Pretreatment of wastewater generated from the holding pens through a sand lane to remove solids;
  - b. Pretreatment of wastewater generated at the slaughterhouse using a rotary drum screen, an equalization tank, and a DAF unit;
  - c. Wastewater storage in properly lined effluent storage pond(s);
  - d. Wastewater application at agronomic rates;
  - e. Compliance with a BOD cycle average loading rate of 50 lbs/acre/day;
  - f. Solids are screened from the waste stream and disposed of offsite;
  - g. Preparation and implementation of a Salinity Evaluation and Minimization Plan;
  - h. Compliance with an Annual Performance-Based Effluent Limit for FDS; and
  - i. Compliance with the Salt and Nitrate Control Programs.
69. Economic prosperity of valley communities and associated industry is of maximum benefit to the people of the state and, therefore, sufficient reason exists to accommodate growth and limited groundwater degradation around the Facility, provided that the terms of the Basin Plan are met. Degradation of groundwater by some typical waste constituents released with discharge from the Facility, after effective source reduction, treatment, and control, and considering the best efforts of the Discharger and magnitude of degradation, is of maximum benefit to the people of the State.
70. The Facility is expected to employ approximately 63 full-time employees during the week, and 2 to 3 employees on weekends. The Facility contributes to the

economic prosperity of the region by providing a necessary service and employment for the local community, by providing incomes for numerous aligned businesses, and by providing a tax base for local and county governments.

71. Based on the foregoing, the adoption of this Order is consistent with the State Water Board's Antidegradation Policy.

### **California Environmental Quality Act**

72. In accordance with CEQA, Public Resources Code section 21000 et seq., Kings County Planning Commission, as lead agency, approved a Mitigated Negative Declaration for construction of the Sandridge Cattle Processing Facility (SCH: 2022050537) on 11 July 2022. The proposed facility will encompass 135 acres and will include an approximately 72,000 square feet of building space consisting of livestock loading areas, a kill floor, coolers, cold storage, dry storage, a cut room, offices, employee facilities, and 1,900 square feet of retail space. The Facility is intended for use to slaughter, butcher, process, and distribute bulk beef products using kosher and halal slaughter techniques. The Mitigated Negative Declaration determined that the proposed Project would not have a significant effect on the environment provided the specified mitigation measures were implemented.
73. To the extent that the construction of any new basins, ponds, surface impoundments, and/or use of existing irrigated lands as new LAAs are authorized under this Order, such features involve minor alterations to land, which are exempt from CEQA procedural requirements pursuant to California Code of Regulations, title 14, section 15304 (CEQA Guidelines).

### **Other Regulatory Considerations**

#### Water Code Section 13149.2

74. These WDRs regulate a facility that may impact a disadvantaged community and tribal community and includes an alternative compliance path that allows the Discharger time to come into compliance with a water quality objective (i.e., salinity). The Discharger has selected the Alternative Salinity Permitting Approach for the Salt Control Program, which provides an alternative approach for compliance with salinity limits through implementation of specific requirements (i.e., support facilitation and completion of the Salinity P&O Study). The Central Valley Water Board has satisfied the outreach requirements set forth in Water Code section 189.7 by conducting outreach in affected disadvantaged and tribal communities through its notice and comment procedures. Central Valley Water Board staff sent a Formal Notification of Determination to Local Native American Tribes and Communities on 28 August 2023. Pursuant to Water Code section 13149.2, and as discussed in the following finding, the Central Valley Water Board

reviewed readily available information and information raised to the Board by interested persons concerning anticipated water quality impacts in disadvantaged or tribal communities resulting from adoption of these WDRs. The Board also considered environmental justice concerns within the Board's authority previously raised by interested persons with regard to those impacts.

75. The Central Valley Water Board anticipates that the issuance of these WDRs will result in water quality impacts within the scope of the Board's authority. Specifically, these WDRs authorize the discharge of wastewater with salinity concentrations above applicable water quality objectives. The Facility's effluent, based on the estimated concentrations provided in the RWD, will have an EC value of about 3,200  $\mu\text{mhos/cm}$  and TDS average around 2,600 mg/L. While these concentrations exceed the water quality objectives for MUN (municipal and domestic supply), the available groundwater data indicates the regional groundwater quality is poor. Water quality data from nearby wells have water quality levels both above and below the applicable drinking water MCLs for salinity as shown in Table 9. The Central Valley Water Board has identified the following measures available and within the scope of its authority to address the impacts of the Facility to the nearby disadvantage communities in Kings County: 1) requiring active participation in the P&O Study and compliance with the Salt and Nitrate Control Programs, which is intended to identify long-term salinity and nitrate management and control practices and/or technologies, 2) establish a performance-based salinity limit for FDS, 3) requiring the Discharger to properly line its wastewater effluent storage ponds, 4) requiring application of wastewater to crops at agronomic rates with irrigation of supplemental water as needed, and 5) requiring the preparation and implementation of Salinity Evaluation and Minimization Plan to establish goals for potentially reducing salinity concentrations in the Facility's discharge. All these measures are implemented by these WDRs.

#### Human Right to Water

76. Pursuant to Water Code section 106.3, subdivision (a), it is "the established policy of the state that every human being has the right to safe, clean, affordable, and accessible water adequate for human consumption, cooking, and sanitary purposes." Although this Order is not subject to Water Code section 106.3, as it does not revise, adopt, or establish a policy, regulation, or grant criterion (see § 106.3, subdivision (b)), it nevertheless promotes the policy by requiring discharges to meet MCLs for drinking water (excluding salinity), which are designed to protect human health and ensure that water is safe for domestic use. For salinity and nitrate, this Order requires compliance with the SCP and NCP, respectively. Although the Basin Plans' Exceptions Policy for Salinity, Nitrate, and/or Boron allows participants in these Programs to obtain limited-term exceptions from MCLs for salinity, nitrate, and/or boron, these Programs are consistent with the Human Right to Water Policy because their over-arching



management goals and priorities include the short-term provision of providing safe drinking water to impacted users and long-term restoration of impacted groundwater basins and sub-basins where reasonable, feasible, and practicable.

#### Threat-Complexity Rating

77. For the purposes of California Code of Regulations, title 23 (Title 23), section 2200, the Facility has a threat-complexity rating of 2-B.
- a. Threat Category “2” reflects waste discharges that can impair receiving water beneficial uses, cause short-term water quality objective violations, cause secondary drinking water standard violations, and cause nuisances.
  - b. Complexity Category “B” reflects any discharger not included in Category A, with either (1) physical, chemical, or biological treatment systems (except for septic systems with subsurface disposal), or (2) any Class II or Class III WMUs.

#### Title 27 Exemption

78. This Order, which prescribes WDRs for discharges of wastewater, is exempt from the prescriptive requirements of California Code of Regulations, title 27 (Title 27), section 20005 et seq (See California Code Regs., title 27, § 20090, subdivision (b)).

#### Stormwater

79. Stormwater at the Facility will be routed to and collected in the two onsite lined effluent storage ponds where it mixes with wastewater for use as an alternative irrigation source or evaporates while stored in the ponds. Because all stormwater at the Facility is collected and disposed of onsite, the Discharger is not required to obtain coverage under the *Statewide General Permit for Storm Water Discharges Associated with Industrial Activities*, State Water Board Order 2014-0057-DWQ, NPDES General Permit CAS000001 (Industrial General Permit) at this time.

#### Scope of Order

80. This Order is strictly limited in scope to those waste discharges, activities and processes described and expressly authorized herein.
81. Pursuant to Water Code section 13264, subdivision (a), the Dischargers are prohibited from initiating the discharge of new wastes (i.e., other than those described herein), or making material changes to the character, volume and timing of waste discharges authorized herein, without filing a new RWD per Water Code section 13260.

82. Failure to file a new RWD before initiating material changes to the character, volume or timing of discharges authorized herein, shall constitute an independent violation of these WDRs.
83. This Order is also strictly limited in applicability to those individuals and/or entities specifically designated herein as “Dischargers,” subject only to the discretion to designate or substitute new parties in accordance with this Order.

### **Procedural Matters**

84. All of the above information, as well as the information contained in the attached Information Sheet (incorporated herein), was considered by the Central Valley Water Board in prescribing the WDRs set forth below.
85. The Discharger, interested agencies and other interested persons were notified of the Central Valley Water Board’s intent to prescribe the WDRs in this Order, and provided an opportunity to submit their written views and recommendations at a public hearing. (See Wat. Code, § 13167.5.)
86. At a public meeting, the Central Valley Water Board heard and considered all comments pertaining to the discharges regulated under this Order.
87. The Central Valley Water Board will review and revise the WDRs in this Order as necessary.

### **REQUIREMENTS**

**IT IS HEREBY ORDERED**, pursuant to Water Code sections 13263 and 13267 that the Discharger and their agents, employees and successors shall comply with the following.

#### **A. Standard Provisions**

Except as expressly provided herein, the Dischargers shall comply with the Standard Provisions and Reporting Requirements dated 1 March 1991 (SPRRs), which are incorporated herein.

#### **B. Discharge Prohibitions**

1. Waste classified as “hazardous” (per Title 22, §66261.1 et seq.), shall not be discharged at the Facility under any circumstance.
2. Waste constituents shall not be discharged or otherwise released from the Facility (including during treatment and storage activities) in a manner that results in:
  - a. Violations of the Groundwater Limitations of this Order; or

- b. Conditions of “nuisance” or “pollution,” as defined per Water Code section 13050.
3. Discharge of wastes other than the Facility’s treated process wastewater at the locations and in the manner described in the Findings and authorized herein is prohibited.
4. Except as otherwise expressly authorized in this Order, waste shall not be discharged to surface waters or surface water drainage courses.
5. Discharge of toxic substances into any wastewater treatment system or the LAAs such that biological treatment mechanisms are disrupted is prohibited.
6. The discharge of process wastewater to the onsite septic/leach field system is prohibited.
7. Discharge of domestic wastewater to the process wastewater treatment system, lined ponds, and/or LAAs is prohibited.

**C. Flow Limitation**

1. Effluent discharged from the Facility to Pond No. 1 (or any other pond receiving wastewater from the Facility) shall not exceed a monthly daily average of 0.055 mgd or a total annual discharge of 14.0 million gallons (monitored at INF-01)

**D. Salinity Limit**

1. The cumulative mass load of salt from the discharge shall not exceed an annual Salinity Mass Loading Limit of 250,000 pounds of FDS per year (calculated as the cumulative salt load from effluent FDS applied to the LAAs on a monthly basis, as described in sections III.B.12 and III.B.14 of the MRP) for the discharge of wastewater sent to the LAAs.

**E. Discharge Specifications**

1. Waste discharges shall remain within the permitted waste treatment/containment structures and LAAs at all times.
2. All treatment systems and equipment shall be operated to optimize discharge quality.
3. All conveyance, treatment, storage, and disposal systems shall be designed, constructed, operated, and maintained to prevent inundation or washout due to floods with a 100-year return frequency.

4. All wastewater generated at the holding pens, manure pad, and dead animal management area shall be treated via the Sand Lane prior to discharge into the effluent storage pond.
5. All wastewater generated at the beef processing and cutting area, and the slaughterhouse floor shall be processed through the on-site treatment system as described in Finding 15.
6. The storage of beef processing wastewater shall be on an engineered lined surface with a leachate collection system as described in the Findings and the May 2023 Pond Liner Report. The engineered lined surface shall meet a hydraulic conductivity standard of at least  $1 \times 10^{-6}$  centimeter per second.
7. Objectionable odors shall not be perceivable beyond the limits of the Facility property at an intensity that creates or threatens to create nuisance conditions.
8. As a means of ensuring compliance with Discharge Specification E.7, the dissolved oxygen (DO) content in the upper one foot of any wastewater treatment or storage pond shall not be less than 1.0 mg/L for three consecutive sampling events. Notwithstanding the DO monitoring frequency specified in the monitoring and reporting program, if the DO in the pond(s) is below 1.0 mg/L for any single sampling event, the Discharger shall implement daily DO monitoring of that pond until the minimum DO concentration is achieved for at least three consecutive days. If the DO in the pond is below 1.0 mg/L for three consecutive days, the Discharger shall report the findings to the Central Valley Water Board in accordance with Section B.1 of the SPRRs. The written notification shall include a specific plan to resolve the low DO results within 30 days of the first date of violation.
9. All ponds and open containment structures shall be managed to prevent breeding of mosquitoes. Specifically:
  - a. An erosion control program shall be implemented to ensure that small coves and irregularities are not created around the perimeter of the water surface.
  - b. Weeds shall be minimized through control of water depth, harvesting, or herbicides.
  - c. Dead algae, vegetation, and debris shall not accumulate on the water surface.

- d. The Discharger shall consult and coordinate with the local Mosquito Abatement District to minimize the potential for mosquito breeding as needed to supplement the above measures.
10. The Discharger shall monitor residual solids accumulation in the effluent storage ponds annually and shall periodically remove residual solids as necessary to maintain adequate storage capacity. Specifically, if the estimated volume of sludge in the pond(s) threatens to impact the pond(s) storage capacity, the Discharger shall clean out the pond(s) within 12 months after the date of the estimate.
11. The Discharger shall design, construct, operate, and maintain all ponds sufficiently to protect the integrity of containment dams and berms and prevent overtopping and/or structural failure. Unless a California-registered civil engineer certifies (based on design, construction, and conditions of operation and maintenance) that less freeboard is adequate, the operating freeboard in any pond shall never be less than two feet (measured vertically from the lowest possible point of overflow). As a means of management and to discern compliance with this requirement, the Discharger shall install and maintain in each pond a permanent staff gauge with calibration marks that clearly show the water level at design capacity and enable determination of available operational freeboard.
12. Newly constructed or rehabilitated berms or levees (excluding internal berms that separate ponds or control the flow of water within a pond) shall be designed and constructed under the supervision of a California registered civil engineer.
13. On or about 1 October of each year, wastewater treatment, storage, and disposal ponds or structures shall have sufficient capacity to accommodate allowable wastewater flow, design seasonal precipitation, and ancillary inflow and infiltration during the winter while ensuring compliance with all requirements of this Order. Design seasonal precipitation shall be based on total annual precipitation using a return period of 100 years, distributed monthly in accordance with historical rainfall patterns.
14. All pens, alleyways, and manure storage areas shall be graded to promote drainage into the wastewater collection system.
15. The animal confinement areas and manure and feed storage areas shall be designed and maintained to convey all water that comes into contact with animal waste to the wastewater collection system. In addition, the

areas shall be graded to minimize standing water as of 72 hours after the last rainfall to limit infiltration of water into underlying soils.

16. The Discharger shall regularly inspect the liner condition of the proposed lined effluent storage pond(s). The Discharger shall maintain and repair the liner as necessary to ensure the integrity of the pond liner is maintained and leakage from the liner is minimized. Necessary repairs shall be completed in reasonable timeframes that are consistent with the severity of the impairment and potential for impact to water quality.
17. The proposed lined effluent storage ponds will contain a Leachate Collection and Removal System (LCRS), with an Action Leakage Rate (ALR) of 1.9 gpm for each LCRS. If leachate generated in either/both LCRS exceeds the ALR, the Discharger shall take actions to inspect and repair the primary liner system if necessary. To ensure compliance with Discharge Specification E.16, if the LCRS exceeds the ALR, the Discharger shall provide a workplan that discusses how the Discharger intends to address the pond liner leak(s) in a timely manner. This workplan shall be submitted within 60 days of identifying the ALR exceedance.
18. The discharge of groundwater from dewatering operations conducted at the effluent storage ponds shall remain onsite, must infiltrate/evaporate within 72-hours, and shall not cause water quality impacts or nuisance conditions (e.g., ponding, vectors, etc).

#### **F. Land Application Area Specifications**

For the purposes of this Order, “land application area” or “LAAs” refers to the discharge areas described in the Findings (i.e., LAA-01 and LAA-02) and shown in Attachment B.

1. Crops shall be grown on the LAAs. Crops shall be selected based on nutrient uptake, consumptive use of water, and irrigation requirements to maximize uptake of nutrients.
2. The perimeter of the LAAs shall be graded to prevent ponding along public roads or other public areas and prevent runoff or overspray onto adjacent properties not owned or controlled by the Discharger.
3. Application of waste constituents to the LAAs shall be at reasonable agronomic rates to preclude creation of a nuisance or unreasonable degradation of groundwater, considering crop, soil, climate and irrigation management system. The annual nutritive loading of the LAAs, including nutritive value of organic and chemical fertilizers, and the wastewater, shall not exceed the annual crop demand.

4. Wastewater from the Facility shall not be applied within:
  - a. 50 feet of a water supply well,
  - b. 50 feet of a surface water or surface water drainage course, or
  - c. 25 feet of a property line or public right-of-way unless the irrigation system is managed to prevent runoff or overspray, in which case a minimum setback of 5 feet shall be maintained.
5. Hydraulic loading of wastewater and irrigation water shall be at reasonable agronomic rates designed to minimize the percolation of wastewater and irrigation water below the root zone (i.e., deep percolation).
6. The BOD loading to the LAAs, calculated as a cycle average as determined by the methods described in the attached MRP, shall not exceed **50 pounds per acre per day (lbs/acre/day)**.
7. The resulting effect of the discharge on soil pH shall not exceed the buffering capacity of the soil profile.
8. Land application of wastewater shall be managed to minimize erosion.
9. The Discharger shall not discharge process wastewater to the LAA when soils are saturated (e.g., during or after significant precipitation).
10. Wastewater shall be distributed uniformly on adequate acreage to preclude the creation of nuisance conditions.
11. Any irrigation runoff shall be confined to the LAA and shall not enter any surface water drainage course or storm water drainage system.
12. The LAA shall be managed to prevent breeding of mosquitos. More specifically:
  - a. All applied irrigation water must infiltrate completely within 48 hours;
  - b. Ditches not serving as wildlife habitat shall be maintained free of emergent marginal, and floating vegetation; and
  - c. Low-pressure and unpressurized pipeline and ditches accessible to mosquitos shall not be used to store process wastewater.
13. Irrigation of the LAAs shall occur only when appropriately trained personnel are on duty.

14. As required by the MRP, LAAs shall be inspected periodically to determine compliance with the requirements of this Order. If an inspection reveals noncompliance or threat of noncompliance with this Order, the Discharger shall temporarily stop land application use immediately and implement corrective actions to ensure compliance with this Order.

#### **G. Groundwater Limitations**

Release of waste constituents from any portion of the Facility shall not cause or contribute to groundwater containing constituent concentrations in excess of the concentrations specified below or in excess of background groundwater quality, whichever is greater:

1. The Primary or Secondary MCLs established in Title 22, excluding salinity.
2. Contain taste or odor-producing constituents, toxic substances, or any other constituents in concentrations that cause nuisance or adversely affect beneficial uses.

#### **H. Solids Disposal Specifications**

1. For the purpose of this Order, residual solids include the solid, semisolid, and liquid organic matter removed during the screening of wastewater.
2. Residual solids shall be removed from screens, and vaults as needed to ensure optimal operation, prevent nuisance conditions, and maintain adequate storage capacity.
3. Any handling and storage of residual solids shall be temporary and controlled and contained in a manner that minimizes leachate formation and precludes infiltration of waste constituents into soils in a mass or concentration that will violate the groundwater limitations of this Order.
4. If removed from the site, residual solids shall be disposed of in a manner approved by the Executive Officer and consistent with Title 27, division 2. Removal for reuse as animal feed, biofuel feedstock, or land disposal at facilities (i.e., landfills, composting facilities, soil amendment sites operated in accordance with valid waste discharge requirements issued by a Regional Water Board) will satisfy this specification.
5. Any proposed change in solids use or disposal practice shall be reported in writing to the Executive Officer at least 90 days in advance of the change.



## I. Provisions

1. The Discharger shall comply with the separately issued **Monitoring and Reporting Program (MRP) R5-2024-0043**, which is part of this Order, and any revisions thereto as ordered by the Executive Officer. The submittal dates of Discharger self-monitoring reports shall be no later than the submittal date specified in the MRP.
2. A copy of this Order (including Information Sheet, Attachments and SPRRs) and the MRP, shall be kept at the Facility for reference by operating personnel. Key operating personnel shall be familiar with their contents.
3. The Discharger shall comply with the Basin Plan amendments adopted in Resolution R5-2018-0034 (and revised per Resolution R5-2020-0057) incorporating the Salt and Nitrate Control Programs for addressing ongoing salt and nitrate accumulation in the Central Valley and developed as part of the Central Valley Salinity Alternatives for Long-Term Sustainability (CV-SALTS) initiative. As described in the Findings, the Discharger selected to be an active participant in the P&O Study for the Salt Control Program and indicated its intention to join the local management zone (Pathway B).
4. In accordance with California Business and Professions Code sections 6735, 7835, and 7835.1, engineering and geologic evaluations and judgments shall be performed by or under the direction of registered professionals competent and proficient in the fields pertinent to the required activities. All technical reports specified herein that contain workplans for investigations and studies, that describe the conduct of investigations and studies, or that contain technical conclusions and recommendations concerning engineering and geology shall be prepared by or under the direction of appropriately qualified professional(s), even if not explicitly stated. Each technical report submitted by the Discharger shall bear the professional's signature and stamp.
5. **By 24 February 2025**, develop and implement a **Salinity Evaluation and Minimization Plan** for the proposed discharge. The Plan shall identify salinity control measures that could further reduce the salinity of the proposed discharge. The Plan shall provide a description of the tasks, cost, and time required to investigate and implement the various elements in the Salinity Control and Minimization Plan. At a minimum, the plan shall include:

- a. An estimate of all the sources of pollutants that will contribute, or potentially contribute, to the loadings of salinity in Facility's proposed process wastewater discharge.
  - b. An analysis of the methods/alternatives that could be used to reduce the sources of salinity that discharge into the facility process wastewater streams.
  - c. A description of the tasks, costs, and time required to investigate and implement various elements in the Salinity Evaluation and Minimization Plan.
  - d. A plan for monitoring the results of the Salinity Evaluation and Minimization Plan.
6. The Discharger submitted a Revised March 2023 Groundwater Monitoring Well Installation Work Plan proposing the installation of up to eight groundwater monitoring wells to monitor groundwater quality in the vicinity of the proposed Facility and the LAAs. Central Valley Water Board staff provided a May 2023 letter concurring that the eight wells as proposed provided sufficient groundwater monitoring for the proposed discharge. The wells are to be installed and sampled prior to the startup of the Facility in 2025.

**At least 120 days prior to beginning operations at the Facility**, the Discharger shall submit a Groundwater Monitoring Well Installation Report for all new groundwater monitoring wells installed to monitor groundwater quality in the vicinity of the proposed Facility, effluent storage ponds, and LAAs. The report shall be prepared in accordance with, and including the items listed in, the second section of **Attachment D** (Requirements for Monitoring Well Installation Workplans and Monitoring Well Installation Reports). The report shall describe the installation and development of all new monitoring wells and explain any deviation from the approved Work Plan.

7. **At least 60 days prior to beginning operations at the Facility**, the Discharger shall submit a **Post-Construction Report** that describes the details of the construction of the two lined effluent storage ponds and certifies the effluent storage ponds were constructed as proposed in the May 2023 Pond Liner Report and per the Construction Quality Assurance Report.
8. The Discharger shall submit the technical reports and work plans required by this Order for consideration by the Executive Officer and incorporate comments the Executive Officer may have in a timely manner, as

appropriate. Unless expressly stated otherwise in this Order, the Discharger shall proceed with all work required by the foregoing provisions by the due dates specified.

9. The Discharger shall comply with all conditions of this Order, including timely submittal of technical and monitoring reports. On or before each report due date, the Discharger shall submit the specified document to the Central Valley Water Board or, if appropriate, a written report detailing compliance or noncompliance with the specific schedule date and task. If noncompliance is being reported, then the Discharger shall state the reasons for such noncompliance and provide an estimate of the date when the Discharger will be in compliance. The Discharger shall notify the Central Valley Water Board in writing when it returns to compliance with the time schedule. Violations may result in enforcement action, including Central Valley Water Board or court orders requiring corrective action or imposing civil monetary liability, or in revision or rescission of this Order.
10. The Discharger shall at all times properly operate and maintain all facilities and systems of treatment and control (and related appurtenances) that are installed or used by the Discharger to achieve compliance with the conditions of this Order. Proper operation and maintenance also includes adequate laboratory controls and appropriate quality assurance procedures. This provision requires the operation of back-up or auxiliary facilities or similar systems that are installed by the Discharger when the operation is necessary to achieve compliance with the conditions of this Order.
11. The Discharger shall use the best practicable cost-effective control technique(s) including proper operation and maintenance, to comply with this Order.
12. As described in the SPRRs, the Discharger shall promptly report to the Central Valley Water Board any material change or proposed change in the character, location, or volume of the discharge.
13. In the event of any change in control or ownership of the Facility or the LAA, the Discharger must notify the succeeding owner or operator of the existence of this Order by letter, a copy of which shall be immediately forwarded to the Central Valley Water Board.
14. To assume operation as Discharger under this Order, the succeeding owner or operator must apply in writing to the Executive Officer requesting transfer of the Order. The request must contain the requesting entity's full legal name, the state of incorporation if a corporation, the name and address and telephone number of the persons responsible for contact with

the Central Valley Water Board, and a statement. The statement shall comply with the signatory paragraph of Standard Provision B.3 and state that the new owner or operator assumes full responsibility for compliance with this Order. Failure to submit the request shall be considered a discharge without requirements, a violation of the Water Code. If approved by the Executive Officer, the transfer request will be submitted to the Central Valley Water Board for its consideration of transferring the ownership of this Order at one of its regularly scheduled meetings.

15. The Central Valley Water Board will review this Order periodically and will revise requirements when necessary.

### **ENFORCEMENT**

If, in the opinion of the Executive Officer, the Discharger fails to comply with the provisions of this Order, the Executive Officer may refer this matter to the Attorney General for judicial enforcement, may issue a complaint for administrative civil liability, or may take other enforcement actions. Failure to comply with this Order may result in the assessment of Administrative Civil Liability of up to \$10,000 per violation, per day, depending on the violation, pursuant to the Water Code, including sections 13268, 13350 and 13385. The Central Valley Water Board reserves its right to take any enforcement actions authorized by law.

### **ADMINISTRATIVE REVIEW**

Any person aggrieved by this Central Valley Water Board action may petition the State Water Board for review in accordance with Water Code section 13320 and California Code of Regulations, title 23, section 2050 et seq. The State Water Board must receive the petition by 5:00 p.m. on the 30th day after the date of this Order; if the 30th day falls on a Saturday, Sunday, or state holiday, the petition must be received by the State Water Board by 5:00 p.m. on the next business day. Copies of [the law and regulations applicable to filing petitions](#) are available on the Internet (at the address below) and will be provided upon request.

([http://www.waterboards.ca.gov/public\\_notices/petitions/water\\_quality](http://www.waterboards.ca.gov/public_notices/petitions/water_quality))

## **ATTACHMENTS**

**Attachment A — Project Location Map**

**Attachment B — Site Parcel and Vicinity Map**

**Attachment C — Proposed Process Water Flow Diagram**

**Attachment D — Requirements for Groundwater Monitoring Well Installation Work Plans**

**Standard Provisions & Reporting Requirements  
Information Sheet**

**Monitoring and Reporting Program R5-2024-0043**

**ATTACHMENT A — PROJECT LOCATION MAP**

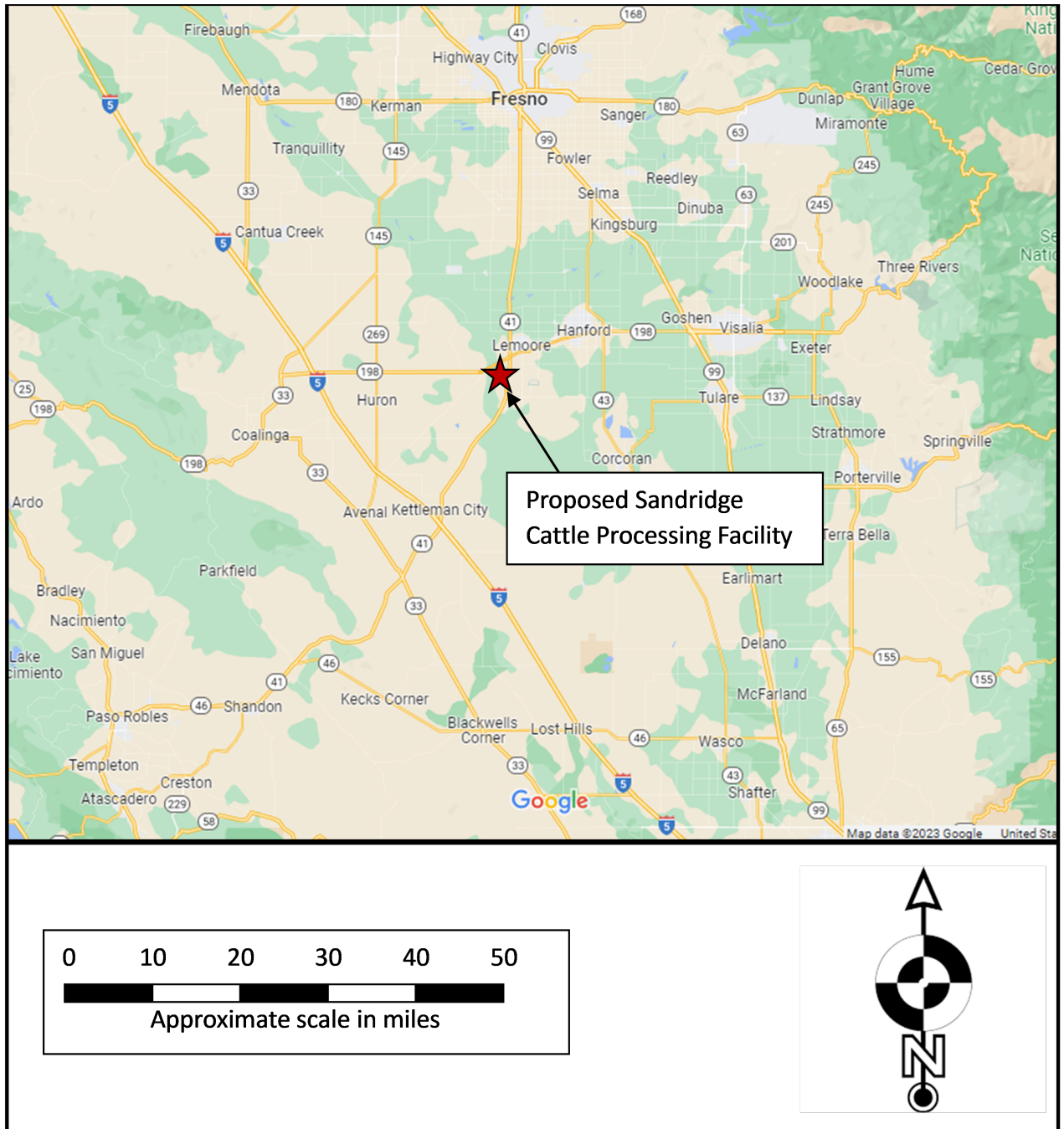

**ATTACHMENT B – SITE PARCEL AND VICINITY MAP**

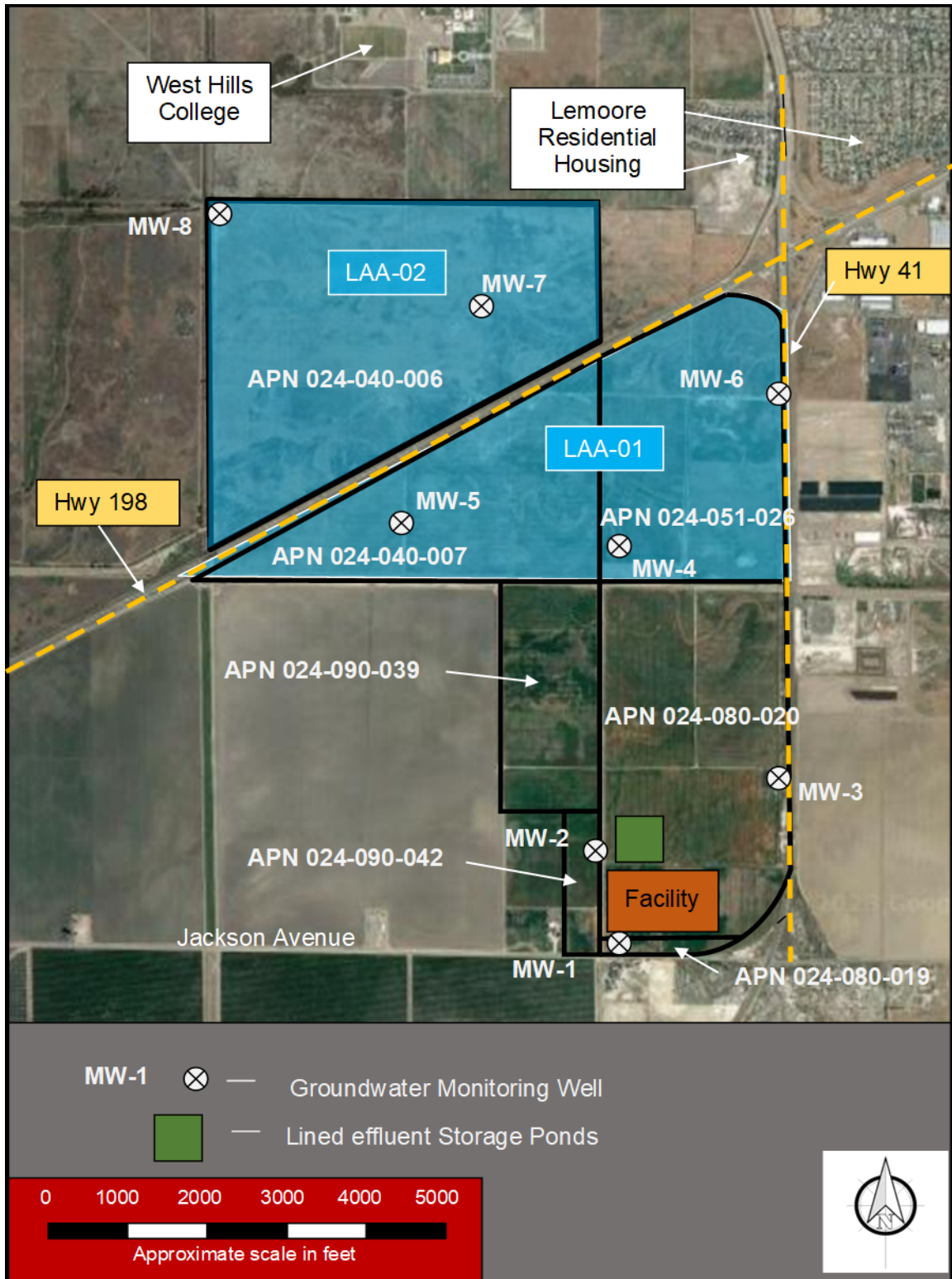



**ATTACHMENT C – PROPOSED PROCESS WATER FLOW DIAGRAM**

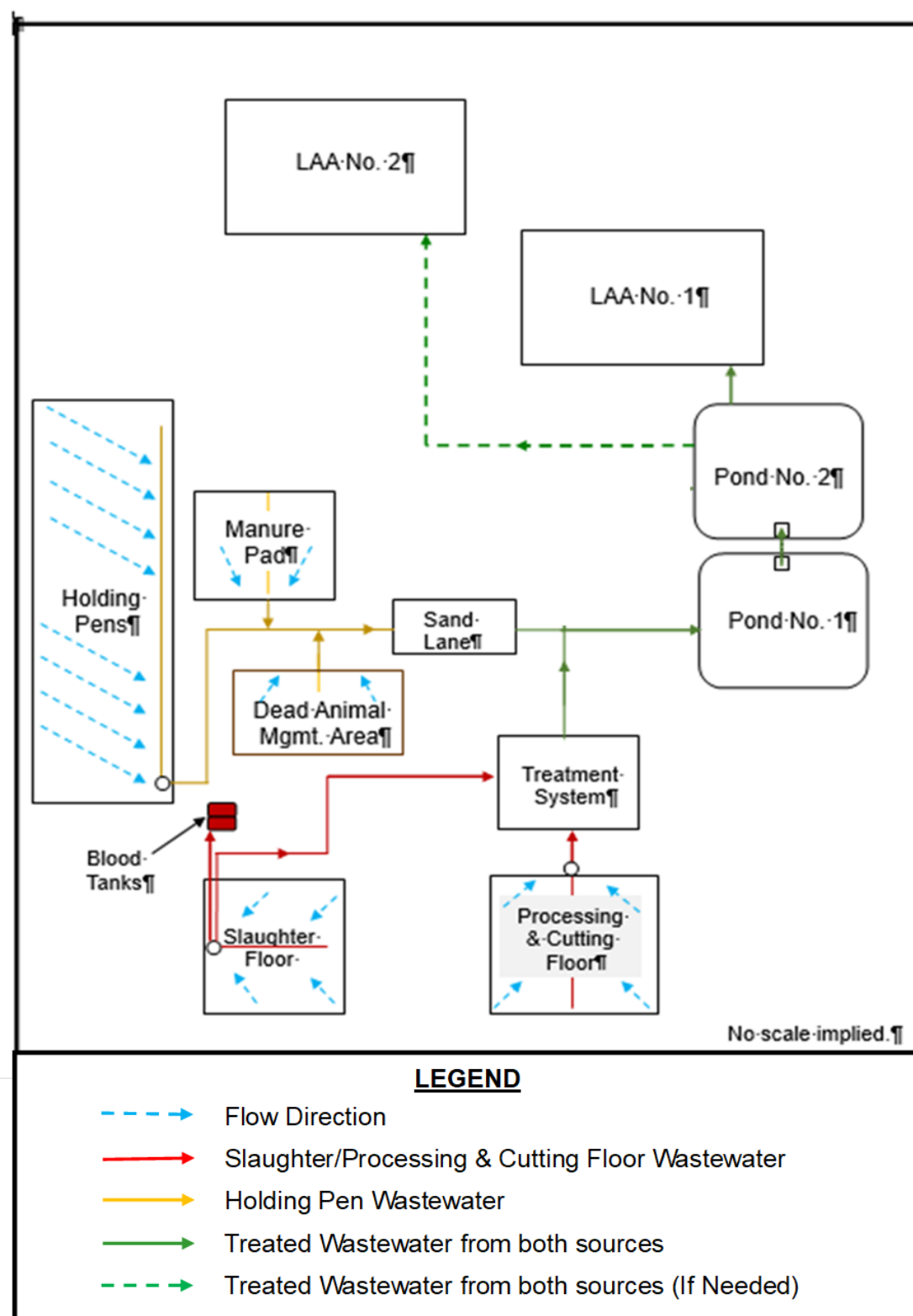



## **ATTACHMENT D — REQUIREMENTS FOR MONITORING WELL INSTALLATION WORKPLANS AND INSTALLATION REPORTS**

Prior to installation of groundwater monitoring wells, the Discharger shall submit a workplan containing, at a minimum, the information listed in Section 1, below. Wells may be installed after staff approves the workplan. Upon installation of the monitoring wells, the Discharger shall submit a well installation report which includes the information contained in Section 2 below. All workplans and reports must be prepared under the direction of, and signed by, a registered geologist or civil engineer licensed by the State of California.

### **SECTION 1 -Monitoring Well Installation Workplan and Groundwater Sampling and Analysis Plan**

The monitoring well installation workplan shall contain the following minimum information:

#### **A. General Information:**

- Purpose of the well installation project
- Brief description of local geologic and hydrogeologic conditions
- Proposed monitoring well locations and rationale for well locations
- Topographic map showing facility location, roads, and surface water bodies
- Large-scaled site map showing all existing on-site wells, proposed wells, surface drainage courses, surface water bodies, buildings, waste handling facilities, utilities, and major physical and man-made features

#### **B. Drilling Details:**

- Description of the on-site supervision of drilling and well installation activities
- Description of drilling equipment and techniques
- Equipment decontamination procedures
- Soil sampling intervals (if appropriate) and logging methods

#### **C. Monitoring Well Design (in narrative and/or graphic form):**

- Diagram of proposed well construction details:
  - Borehole diameter
  - Casing and screen material, diameter, and centralizer spacing (if needed)

- Type of well caps (bottom cap either screw on or secured with stainless steel screws)
- Anticipated depth of well, length of well casing, and length and position of perforated interval
- Thickness, position and composition of surface seal, sanitary seal, and sand pack
- Anticipated screen slot size and filter pack

**D. Well Development (not to be performed until at least 48 hours after sanitary seal placement):**

- Method of development to be used (i.e., surge, bail, pump, etc.).
- Parameters to be monitored during development and record keeping technique.
- Method of determining when development is complete.
- Disposal of development water.

**E. Well Survey (precision of vertical survey data shall be at least 0.01 foot):**

- Identify the Licensed Land Surveyor or Civil Engineer that will perform the survey.
- Datum for survey measurements.
- List well features to be surveyed (i.e. top of casing, horizontal and vertical coordinates, etc).

**F. Schedule for Completion of Work**

**G. Appendix: Groundwater Sampling and Analysis Plan (SAP)**

The Groundwater SAP shall be included as an appendix to the workplan, and shall be utilized as a guidance document that is referred to by individuals responsible for conducting groundwater monitoring and sampling activities.

Provide a detailed written description of standard operating procedures for the following:

- Equipment to be used during sampling
- Equipment decontamination procedures
- Water level measurement procedures
- Well purging (include a discussion of procedures to follow if three casing volumes cannot be purged)

- Monitoring and record keeping during water level measurement and well purging (include copies of record keeping logs to be used)
- Purge water disposal
- Analytical methods and required reporting limits
- Sample containers and preservatives
- Sampling
  - General sampling techniques
  - Record keeping during sampling (include copies of record keeping logs to be used)
  - QA/QC samples
- Chain of Custody
- Sample handling and transport

## **SECTION 2 - Monitoring Well Installation Report**

The monitoring well installation report must provide the information listed below. In addition, the report must also clearly identify, describe, and justify any deviations from the approved workplan.

### **A. General Information:**

- Purpose of the well installation project
- Brief description of local geologic and hydrogeologic conditions encountered during installation of the wells
- Number of monitoring wells installed and copies of County Well Construction Permits
- Topographic map showing facility location, roads, surface water bodies
- Scaled site map showing all previously existing wells, newly installed wells, surface water bodies, buildings, waste handling facilities, utilities, and other major physical and man-made features.

### **B. Drilling Details (in narrative and/or graphic form):**

- On-site supervision of drilling and well installation activities
- Drilling contractor and driller's name
- Description of drilling equipment and techniques

- Equipment decontamination procedures
- Soil sampling intervals and logging methods
- Well boring log (including the following):
  - Well boring number and date drilled
  - Borehole diameter and total depth
  - Total depth of open hole (same as total depth drilled if no caving or back-grouting occurs)
  - Depth to first encountered groundwater and stabilized groundwater depth
  - Detailed description of soils encountered, using the Unified Soil Classification System

**C. Well Construction Details (in narrative and/or graphic form).**

- Well construction diagram, including:
  - Monitoring well number and date constructed
  - Casing and screen material, diameter, and centralizer spacing (if needed)
  - Length of well casing, and length and position of perforated interval
  - Thickness, position and composition of surface seal, sanitary seal, and sand pack
  - Type of well caps (bottom cap either screw on or secured with stainless steel screws)

**D. Well Development:**

- Date(s) and method of development
- How well development completion was determined
- Volume of water purged from well and method of development water disposal
- Field notes from well development should be included in report

**E. Well Survey (survey the top rim of the well casing with the cap removed):**

- Identify the coordinate system and datum for survey measurements
- Describe the measuring points (i.e. ground surface, top of casing, etc.)
- Present the well survey report data in a table

Waste Discharge Requirements Order R5-2024-0043  
Sandridge Partners, L.P.  
Sandridge Cattle Lemoore Processing Facility  
Sandridge Cattle Lemoore Processing Facility Kings County

D.5

Include the Registered Engineer or Licensed Surveyor's report and field notes in appendix.

CALIFORNIA REGIONAL WATER QUALITY CONTROL BOARD  
CENTRAL VALLEY REGION

WASTE DISCHARGE REQUIREMENTS ORDER R5-2024-0043  
FOR  
SANDRIDGE PARTNERS, L.P.  
SANDRIDGE CATTLE LEMOORE PROCESSING Facility  
KINGS COUNTY

**INFORMATION SHEET**

**BACKGROUND**

Sandridge Partners, L.P. (Sandridge or Discharger) is proposing to construct a cattle processing facility (Facility) at 19668 Jackson Avenue just southwest of the City of Lemoore in Kings County. When fully operational, the Facility proposes to harvest up to 210 cattle per day operating five days per week or 255 days per year.

**Table 1 – Project Correspondence**

Date	Submittal/Item	Description and Central Valley Water Board Staff Response
4/11/22	Initial RWD for Project	Staff letter and memo determined April 2022 RWD to be incomplete.
6/28/22	Revised RWD	On 7/12/22 Staff called and emailed consultant with questions/comments on revised RWD.
10/14/22	Revised RWD	On 11/16/2022 Staff emailed consultant stating Oct 2022 RWD appeared complete but required timeline for submitting Pond Liner Design Report and Groundwater Monitoring Well Installation Report.
2/2/23	Monitoring Well Work Plan and Pond Liner Report	On 2/23/23 Staff had teleconference with Discharger and consultant expressing concerns with both reports, including concerns about shallow groundwater in the area and maintaining at least 5 feet of groundwater separation from bottom of ponds, limited soil borings around actual proposed pond locations, and location of some groundwater monitoring wells.
3/30/23	Revised Monitoring Well Work Plan and Pond Liner work Plan	Discharger advanced borings around proposed pond locations, groundwater was encountered in all soil borings at depths ranging from 5.5 to 8 feet below ground surface (bgs). Staff reviewed both documents and responded in a 2 May 2023 13267 letter to Sandridge that the March 2023 Monitoring Well Work Plan addressed Staff’s concerns with the number and the locations of the proposed monitoring wells but that Staff still had concerns about the proposed installation of two double-lined effluent storage ponds (i.e., demonstrating groundwater would not come within 5

Sandridge Partners, L.P.

Sandridge Cattle Lemoore Processing Facility

Kings County

**INFORMATION SHEET**

Date	Submittal/Item	Description and Central Valley Water Board Staff Response
		feet of bottom of ponds). Staff also had concerns about aeration of ponds
5/30/23	Response to 13267 Letter	Response included a revised RWD, Pond Liner Work Plan, and Groundwater Monitoring Plan. The May 2023 Pond Liner Report proposes that the base of the proposed effluent storage ponds be constructed <u>at or above the existing ground level</u> . If groundwater remains greater than five feet bgs, then the required 5-foot separation between the groundwater and the base of the pond can be maintained. <u>If groundwater is less than 5 feet bgs, a dewatering system is proposed to be set at about three (3) feet below the lowest point (base of sump).</u>

Sandridge submitted several Reports of Waste Discharge (RWDs) to the Central Valley Regional Water Quality Control Board (Central Valley Water Board) in support of the proposed Facility. The first was submitted in April 2022. Staff reviewed the April 2022 RWD and responded in a 29 April 2022 letter that additional information was required to consider the RWD complete. Sandridge submitted revised RWDs in June 2022, September 2022, March 2023, and May 2023. Staff replied in a 16 November 2022 email that the revised September 2022 RWD had addressed the information requested in the 29 April 2022 letter.

On 2 February 2023, Sandridge submitted a 24 January 2023 *Monitoring Well Installation and Sampling Plan* (Monitoring Well Work Plan) prepared by Mason Geoscience and a 1 February 2023 *Design Report and Work Plan With Technical Report of Waste Discharge for Proposed Wastewater Retention Pond Liner* (Pond Liner Report) prepared by 4Creeks, Inc and signed by Kyle Parreira (RCE 89070). Staff reviewed the documents and had concerns regarding the number and location of the groundwater monitoring wells proposed to monitor the proposed discharge/reuse of wastewater in the proposed land application areas, and questions regarding the depth to groundwater encountered during the field investigations (as shallow as 5-feet bgs in the area of the Facility) and that no borings were advanced in the in the area of the proposed ponds. Staff discussed those issues with the Discharger and their consultants in a 23 February 2023 teleconference.

On 30 March 2023, Sandridge submitted a revised March 2023 Monitoring Well Work Plan and a revised March 2023 Pond Liner Report. The monitoring Well Work Plan proposed a sixth groundwater monitoring well upgradient of land application area LAA-01. Staff reviewed the March 2023 Monitoring Well Work Plan and responded in a 2 May 2023 13267 letter to Sandridge that the March 2023 Monitoring Well Work Plan

Sandridge Partners, L.P.

Sandridge Cattle Lemoore Processing Facility

Kings County

**INFORMATION SHEET**

addressed Staff's concerns with the number and the locations of the proposed groundwater monitoring wells. Sandridge submitted a 30 May 2023 response letter proposing a new schedule for groundwater monitoring well installation. The May 2023 letter included the following: *Monitoring well construction is estimated to commence approximately 160 days prior to facility operation. At least one round of sampling of the newly constructed monitoring wells is estimated to be completed 120 days prior to facility operation.* Staff concurred with the proposed schedule. This Order contains Provision I.6. that requires the Discharger to submit a well completion report. A guidance document to assist in the preparation of a well completion report is included as Attachment D.

The March 2023 Pond Liner Report did not sufficiently address Staff's concerns regarding shallow groundwater and the lined effluent storage ponds. The borings advanced in the vicinity of the proposed ponds indicated groundwater present at 5.5 feet bgs. The March 2023 design proposed that the ponds be excavated below the ground surface; however, given that groundwater was encountered at 5.5 feet bgs there would not be five-foot of separation between the underlying groundwater and the lined base of the ponds. A subsequent May 2023 Pond Liner Report proposed that the base of the effluent storage ponds be constructed at or above the existing ground level. If groundwater remains greater than five feet bgs, then five feet of separation between the groundwater and the base of the pond can be maintained. Additionally, should groundwater rise to less than five feet bgs, a dewatering system is proposed to be set at about three feet below the lowest point of the ponds (base of sumps) at an elevation of about 202.5 feet above mean sea level. This elevation was indicated by Mason Geosciences staff to be the same as the "high water level" encountered in the borings advanced in March 2023 near the proposed effluent storage ponds. Staff concurred that constructing the ponds above grade and installing a dewatering system should groundwater rise above 5 feet bgs appeared sufficient to minimize the threat of groundwater rising into contact with the pond liner.

**PROPOSED FACILITY**

The May 2023 RWD indicates the proposed Facility will include:

- 75,000 square feet of building space that will include livestock loading and holding areas, a kill and processing floor, coolers, cold storage, dry storage, a cut room, offices, employee facilities, and 1,900 square feet of retail space (the Facility will produce processed beef for sale to consumers).
- A 7,200 square foot concrete pad and shelter for the wastewater treatment system.
- A 33,000 square foot concrete manure stacking pad that will be sloped to a drainage swale that drains to the sand lane.



- A 700 square foot sand lane. Wastewater will flow down the concrete sand land where solids are settled/filtered from the effluent. The settled solids are removed from the sand lane and hauled to the manure stacking pad.
- Two, double-lined effluent storage ponds equipped with aerators, and constructed for water storage, BOD aeration control, and retention for irrigation. According to the May 2023 Pond Liner Report, the capacity of each pond is about to about 1.9 million gallons and a combined capacity of about 3.8 million gallons.

The properties proposed for the operation of the Facility include seven parcels covering approximately 1,240 acres of farmland as summarized in Table 2.

**Table 2 – Project APNs, Acreage, and Related Facility Areas**

APN	Acres	Project Area
024-040-007	202.2	Western portion of land application area
024-051-026	213.4	Eastern portion of land application area
024-040-006	413.3	Reserve land application area
024-090-039	100.5	Vacant land northwest of Facility
024-080-020	284.2	Facility. Effluent storage ponds. Beef loading & processing. Slaughterhouse
024-080-019	5.7	Southern Frontage
024-090-042	20	Vacant land west of Facility
<b>Total</b>	<b>1,239.3</b>	---

The Facility will be situated within the southern portion of APN 024-080-020 and will be bounded to the south by Jackson Avenue, by Highway 41 to the east, and primarily agricultural lands to the west and north. Highway 198 divides LAA-01 and LAA-02. The Kings Speedway racetrack is about three quarters of a mile to the northeast. Residential housing (Lemoore) is about 2,000 feet from the northeast corner of LAA-01 and West Hills Community College is about three quarters of a mile north of the same point.

**ANTICIPATED WASTEWATER GENERATION, TREATMENT, AND QUALITY**

Wastewater will be generated at the proposed Facility from three general areas: (1) the holding pens, (2) the cutting and processing, (3) and the slaughter floor. Wastewater generated from the holding pens will include cow urine, water spillage, and cattle and pen washdown water. The pens will be rinsed daily and washdown water/effluent will gravity flow to area drains with screens, which will then discharge into a concrete sand lane allowing solids to settle out and the effluent to gravity flow via pipeline to the first of

two double lined effluent storage ponds (Pond No. 1). The solids that settle out will be hauled to the onsite manure stacking pad.

Wastewater generated at the slaughterhouse will contain a composition of fats, fibers, organic content, and pathogens. Blood will be collected in holding tanks in a refrigerated area, which is picked up by a licensed rendering company and taken offsite. Washdown water flows into floor drains with screens to remove solids. The solids will be routed to a holding tank and the wastewater to an influent sump prior to treatment. Solids in the holding tank will be picked up by Baker Commodities for processing at their rendering site.

The September 2022 revised RWD estimates that the holding pens will generate 1,125 gallons of wastewater per day (gpd) and the cutting floor of the slaughterhouse will generate about 52,500 gpd for a combined total of about 53,635 gallons per day.

The slaughterhouse effluent will be routed to a treatment area that consists of the following elements, as described in the September 2022 RWD:

- Rotary drum screen
- Aerated equalization tank
- pH adjustment
- Flocculation
- Dissolved air floatation

Wastewater will be routed through a rotary drum screen and then discharged into an equalization tank that allows for a constant flow of wastewater to the flocculator. The treatment process will use sodium hydroxide and sulfuric acid to adjust the pH of the wastewater and Coagulant 185 and Floc 265 to increase coagulation and flocculation. Once the treated water enters Pond No. 1, it will be further aerated to reduce the BOD concentrations in the wastewater prior to land application.

The May 2023 RWD contains estimates of pre-treated slaughterhouse wastewater quality as shown below in Table 2. A foot note in the RWD attributes the data listed below as “EPA 2004 Guidance” results to an EPA, 2004 publication and states, “*values derived from previously conducted studies evaluating slaughterhouse wastewater treatment, characteristics, and limitations*”. The May Revised 2023 RWD estimated the quality of the treated wastewater discharged to Pond No. 1 and Pond No. 2 as shown in Table 3. The Discharger’s consultant indicated the values presented for Ponds No. 1 and No. 2 were derived from previously conducted studies on similar sized slaughterhouse operations.

**Table 2 – Anticipated Wastewater Values**

Constituent	Units	2004 EPA Guidance	Pond No.2 Effluent
EC	µmhos/cm	3,300	3,273
TDS	mg/L	1,298	2,600
FDS	mg/L	1,100	1,950
Nitrate (as N)	mg/L	100	240
Ammonia (as N)	mg/L	40	209
Chloride	mg/L	86	110
Sodium	mg/L	37	190
BOD	mg/L	3,870	450

**PROPOSED STORAGE AND REUSE OF EFFLUENT**

**Proposed Liner Effluent Storage Ponds:** Sandridge is proposing to construct two double-lined high-density polyethylene (HDPE) effluent storage ponds with leachate collection and removal systems (LCRS) installed between the two liners. The capacity of each pond is estimated to be about 1.9 million gallons with 2 feet of freeboard and results in a combined capacity of about 3.8 million gallons. The May 2023 Pond Liner Report proposed the ponds be constructed above the existing grade.

The effluent storage ponds will have leachate collection and removal systems (LCRS) installed between the double liner system that are equipped with pan lysimeters to monitor for potential leakage. An 8-inch diameter high density polyethylene (HDPE) pipe will be installed from the LRCS to the top of the pond at the anchor trench to allow for leaks to be detected and for the leachate to be pumped from the LRCS. With a coverage of 1.43 acres, the Revised Pond Liner Report indicates the LRCS will have an estimated leakage rate of 1.94 gallons per minute.

**Proposed Land Application Areas:**

The proposed land application area of wastewater will be to 415 acres of farmland (369 net acres for land application after development) contained in two APNs (APN 024-051-026 [213 acres] and APN 024-040-007 [202 acres]) located about a mile north of the proposed Facility. Another parcel, APN 024-040-006, borders LAA-01 to the northwest and consists of 412 acres of farmland (399 net acres for land application after development) and is proposed for use as an alternate land application area (LAA-02) if needed.

**GROUNDWATER CONSIDERATIONS**

Groundwater conditions are discussed in Findings 33 to 38 of the Order.

Sandridge Partners, L.P.

Sandridge Cattle Lemoore Processing Facility

Kings County

**INFORMATION SHEET****ANTIDEGRADATION**

Antidegradation analysis and conclusions are discussed in Findings 65 to 71 of the Order.

**DISCHARGE PROHIBITIONS, EFFLUENT LIMITATIONS, DISCHARGE SPECIFICATIONS, AND PROVISIONS**

The Order sets an annual total discharge of 14.0 million gallons per year for discharge into Pond No. 1, as measured at INF-01. The Order also specifies an annual Performance-Based Effluent Salt Loading Limit of 250,000 pounds per year calculated using FDS since the Discharger selected to participate in the Prioritization and Optimization Plan for the Salt Control Program.

This Order also contains the following provisions including:

- Provision I.5 requires the Discharger to submit a Salinity Evaluation and Minimization Plan.
- Provision I.6 requires the Discharger to submit a Groundwater Monitoring Well Installation Report that describes the installation, development, and the initial sampling results of the new groundwater monitoring wells.
- Provision I.7 requires the Discharger to certify the double-lined effluent storage ponds were constructed as proposed.

**MONITORING REQUIREMENTS**

Section 13267 of the California Water Code authorizes the Central Valley Water Board to require monitoring and technical reports as necessary to investigate the impact of waste discharges on Waters of the State. Water Code Section 13268 authorizes assessment of civil administrative liability where appropriate. The Order includes influent, effluent, pond, source water supply, land application area, plant tissue, soil, supplemental irrigation water, and solids monitoring requirements. This monitoring is necessary to characterize the discharge and evaluate compliance with the requirements and specifications in the Order.

**SALT AND NITRATE CONTROL PROGRAMS REGULATORY CONSIDERATIONS**

As part of the Central Valley Salinity Alternatives for Long-Term Sustainability (CV-SALTS) initiative, the Central Valley Water Board adopted Basin Plan amendments (Resolution R5-2018-0034) incorporating new programs for addressing ongoing salt and nitrate accumulation in the Central Valley at its 31 May 2018 Board Meeting. On 16 October 2019, the State Water Resources Control Board adopted Resolution No. 2019-0057 approving the Central Valley Water Board Basin Plan amendments and also directed the Central Valley Water Board to make targeted revisions to the Basin Plan amendments within one year from the approval of the Basin Plan amendments by the

Sandridge Partners, L.P.

Sandridge Cattle Lemoore Processing Facility

Kings County

**INFORMATION SHEET**

Office of Administrative Law. The Office of Administrative Law approved the Basin Plan amendments on 15 January 2020 (OAL Matter No. 2019-1203-03) and were revised by the Central Valley Water Board in 2020 with [Resolution R5-2020-0057](https://www.waterboards.ca.gov/centralvalley/board_decisions/adopted_orders/resolutions/r5-2020-0057_res.pdf) ([https://www.waterboards.ca.gov/centralvalley/board\\_decisions/adopted\\_orders/resolutions/r5-2020-0057\\_res.pdf](https://www.waterboards.ca.gov/centralvalley/board_decisions/adopted_orders/resolutions/r5-2020-0057_res.pdf)).

For the Salt Control Program, dischargers that are unable to comply with the stringent salinity requirements will instead need to meet performance-based requirements and participate in a basin-wide effort known as the Prioritization and Optimization Study (P&O Study) to develop a long-term salinity strategy for the Central Valley. On 22 June 2022 the Discharger submitted a Notice to Intent electing to participate in the P&O Study. CV-SALTS sent a Certificate of Participation on 5 July 2022 and issued Sandridge **CV-SALTS: ID 3613** for the Salt Control Program.

For the Nitrate Control Program, dischargers may comply with the new nitrate program either individually (Pathway A) or collectively with other dischargers (Pathway B). For the Nitrate Control Program, the discharge is within Groundwater Basin 5-022.12 (San Joaquin Valley – Tulare Lake), which is a Priority 2 Basin. Notices to Comply for Dischargers in Priority 2 Basins were sent in December 2023 and responses are due by February 2025. The Discharger has indicated they intend to join the Local Management Group.

The CV-SALTS initiative will result in regulatory changes that will be implemented through conditional prohibitions and modifications to many WDRs regionwide, including the WDRs that regulate discharges from the Facility. More [information regarding the CV-SALTS regulatory planning process](https://www.waterboards.ca.gov/centralvalley/water_issues/salinity/) can be found at the following link: [https://www.waterboards.ca.gov/centralvalley/water\\_issues/salinity/](https://www.waterboards.ca.gov/centralvalley/water_issues/salinity/)

**REOPENER**

The conditions of discharge in the Order were developed based on currently available technical information and applicable water quality laws, regulations, policies, and plans, and are intended to assure conformance with them. The Order sets limitations based on the information provided thus far. If applicable laws and regulations change, or once on new information is obtained that will change the overall discharge and its potential to impact groundwater, it may be appropriate to reopen the Order.

**LEGAL EFFECT OF RESCISSION OF PRIOR WDRS OR ORDERS ON EXISTING VIOLATIONS**

The Central Valley Water Board's rescission of prior waste discharge requirements and/or monitoring and reporting orders does not extinguish any violations that may have occurred during the time those waste discharge requirements or orders were in effect. The Central Valley Water Board reserves the right to take enforcement actions to address violations of prior prohibitions, limitations, specifications, requirements, or provisions of rescinded waste discharge requirements or orders as allowed by law.