

CALIFORNIA REGIONAL WATER QUALITY CONTROL BOARD
CENTRAL VALLEY REGION

ORDER R5-2014-0059

WASTE DISCHARGE REQUIREMENTS

FOR
HUGHSON NUT, INC.
VERDUGA ROAD ALMOND PROCESSING FACILITY
STANISLAUS COUNTY

The California Regional Water Quality Control Regional Board, Central Valley Region, (hereafter Central Valley Water Board) finds that:

1. On 20 August 2007, Hughson Nut, Inc. submitted a Report of Waste Discharge (RWD) that describes an existing almond processing facility that generates process wastewater and residual solids that are discharged to land. Additional information to complete the RWD was submitted on 13 October 2010; 17 March 2011; and 12 August, 4 and 9 September, 21 November 2013, and 14 February 2014.
2. Hughson Nut, Inc. (hereafter "Discharger") owns and operates the facility that generates the waste and the land discharge areas and is responsible for compliance with these Waste Discharge Requirements (WDRs).
3. The facility is at 1825 Verduga Road in Hughson (Section 7, T4S, R11E, MDB&M). The facility occupies Assessor's Parcel Number (APN) 019-018-041, as shown on Attachment A, which is attached hereto and made part of this Order by reference.

Facility and Discharge

4. The facility began operation in 1985 and processes harvested almonds that are marketed for human consumption. The facility receives hulled and shelled raw almonds and sorts them by variety, size, and quality. Sorted almonds are transferred for either dry processing or blanching to remove the skin. The blanching process was added in 1988 and is the only process that generates process wastewater. The facility operates up to 22 hours a day, 6 days a week during the peak almond processing season, which is typically September through April. During the peak season the facility employs up to 150 workers.
5. The facility neighbors an almond hulling and shelling company as shown on Attachment B, which is attached hereto and made part of this Order by reference. The two companies are owned and operated independently of each other.
6. The facility obtains its water supply from an onsite groundwater well. The Discharger installed a flow meter for the well in 2012. This water is used for the almond blanching process and domestic use in restrooms. There are two supply wells but only one is used to supply water to the facility (the Plant Well). The second well is not used. The Plant Well was constructed in 1989 with a depth of 245 feet. Based on the 2012

Consumer Confidence Report submitted to the California Department of Public Health (CDPH), the process water supply is generally of high quality with a total dissolved solids concentration of 240 mg/L.

7. The blanching process generates wastewater from five primary sources:
 - a. Prewashing – Almonds are prewashed and soaked in a 150 gallon vat. The prewash water is filtered and reused for up to 8 hours.
 - b. Blanching – Almonds travel through a spiral auger and are steamed to loosen the skins.
 - c. Rinsing – Blanched almonds are rinsed to remove skins and debris prior to being conveyed to roasting, slicing, dicing, and slivering processes.
 - d. Facility cleaning – The blanching facility is cleaned and sanitized daily to meet Federal food handling regulations.
 - e. Boiler blowdown – Blowdown is performed daily for 15 seconds to test the process valving. An annual blowdown is also performed. Boiler water is discharged to Pond 1 and the precipitate is removed and hauled off site for disposal.
8. The Discharger uses food grade cleaners, detergents, sanitizers, and degreasers for facility cleaning. Active chemical ingredients include quaternary ammonium chlorides, sodium hydroxide, and sodium hypochlorite. Typically facility cleaning chemicals are used at a total rate less than ten gallons per month.
9. Chemicals are added to the boiler feed water, including triphosphoric acid, pentasodium salt, sodium sulfite, and morpholine. The total rate that boiler chemicals are used is typically less than 35 gallons per month. Precipitate is cleaned from the boiler annually and disposed of at a regulated landfill.
10. The majority of the wastewater is produced during the blanching process. The Discharger has not metered wastewater flows. The 2007 RWD estimates the monthly average wastewater flow to be 15,000 to 16,000 gallons per day (gpd) during the peak operating season based on the blancher size. Flows during the off peak season are estimated to be approximately 10,000 gpd. Wastewater generated from cleaning is estimated to be approximately 3,000 gallons per month.
11. In September 2013 the Discharger provided information to amend the 2007 RWD. The Discharger states that almond production has increased from approximately 45,000 to 90,000 pounds per day and the monthly average wastewater flow is now approximately 41,000 gpd. The Discharger is requesting a monthly average flow limit of 64,000 gpd to accommodate future expansion.
12. Wastewater flow rates are estimated based on metered flows from the supply well and estimated water losses during the blanching process and from domestic use. The estimation of wastewater flows is not accurate and, therefore, this Order requires the Discharger to install a flow meter to reliably measure wastewater flows.

13. All process wastewater is run through a parabolic screen prior to being discharged to Pond 1, which is adjacent to the blanching facility as shown on Attachment B. Pond 1 is a concrete lined aeration pond with a holding capacity of 0.39 acre-feet at one foot of freeboard.
14. Effluent from Pond 1 gravity flows to Pond 2, which is located at the southwest corner of the property. Pond 2 is an unlined earthen pond with a holding capacity of 2.12 acre-feet at two feet of freeboard. Pond 2 is also aerated. Disposal of wastewater occurs through evaporation and percolation from Pond 2, and irrigation of 55 acres of on-site almond orchards. A process flow schematic is presented on Attachment C, which is attached hereto and made part of this Order by reference.
15. In the September 2013 RWD amendment, the Discharger provided recent wastewater character of the process water supply, influent to Pond 1, and effluent from Pond 2, which is summarized in the following table:

Constituent	Units	Water Supply ¹	Influent to Pond 1 ²	Effluent From Pond 2 ²
pH	Standard Units	--	6.5	6.8
BOD ₅	mg/L	--	1,492	360
TDS	mg/L	240	2,175	678
FDS	mg/L	--	194	278
Chloride	mg/L	11	25	76
Nitrate (as N)	mg/L	2.5	5.3	< 0.5
Total Nitrogen	mg/L	--	77	53

¹ 2012 Consumer Confidence Report for onsite groundwater supply well.

² Average of weekly samples from 26 July to 15 August 2013 (5 weeks).

16. Wastewater from Pond 2 is used to irrigate 55 acres of onsite almond orchards. The RWD indicates that the land application area is divided into three fields that are flood irrigated, as shown in Attachment B. While the 2007 RWD stated that wastewater from Pond 2 is used to irrigate 10.5 acres of almond orchards (LAA Field 3), the September 2013 RWD amendment clarified that 55 acres of onsite almond orchards are irrigated with wastewater.
17. At the proposed wastewater generation rate of 64,000 gpd, the facility's wastewater would supply approximately 15.9 inches of water over the 55-acre LAA per year. The average crop evapotranspiration rate for mature almond trees is 42 inches per year, which is substantially greater.
18. Supplemental irrigation water is utilized when the water needs of the almond trees are not met by precipitation and the application of process wastewater. Supplemental irrigation water is obtained from an onsite groundwater well and from the Turlock

Irrigation District (TID). Irrigation water from TID is typically applied two or three times a year. Both the process wastewater and TID water are applied by flood irrigation. Water from the groundwater well can also be applied as needed using drip irrigation.

19. The Discharger submitted a water balance for the 100-year, 365-day precipitation event based on the proposed wastewater flow of 64,000 gpd. The water balance indicates that from April through October, the volume of wastewater generated is insufficient to meet the water demand of the almond orchard. In order to prevent spills from the wastewater ponds during the 100-year return event, approximately 5 inches of wastewater would have to be land applied between November and March when the orchard typically does not need to be irrigated. The discharger states that these winter applications will not exceed the percolation capacity of the soil and that wastewater application during the wet months will be managed to prevent standing water and runoff during storm events. Specifically, wastewater will not be applied immediately before or after a storm event to prevent runoff.
20. Excessive application of high organic strength wastewater to land can create objectionable odors, soil conditions that are harmful to crops, and degradation of underlying groundwater with nitrogen species and metals, as discussed below. Such groundwater degradation can be prevented or minimized through implementation of best management practices which include planting crops to take up plant nutrients and maximizing oxidation of BOD to prevent nuisance conditions.
21. Typically, irrigation with high strength wastewater results in high BOD loading on the day of application. It is reasonable to expect some oxidation of BOD at the ground surface, within the evapotranspiration zone and below the root zone within the vadose (unsaturated) zone. The maximum BOD loading rate that can be applied to land without creating nuisance conditions or leaching of metals can vary significantly depending on soil conditions and operation of the land application system.
22. The *Manual of Good Practice for Land Application of Food Processing/Rinse Water* prepared by the California League of Food Processors recommends a BOD loading rate less than or equal to 100 pounds per acre per day to pose minimal risk of groundwater degradation. The average effluent BOD concentration is 360 mg/L but Discharger did not provide the irrigation cycle to determine the actual cycle average BOD loading rate. Assuming an even application of the proposed 64,000 gpd wastewater flow over the 55 acres, the estimated annual average BOD loading rate would be 3.5 pounds per acre per day. Assuming a 15-day cycle time, the cycle average loading would be 15 lb/ac/day, which poses a low risk of reducing conditions.
23. The nitrogen demand of almond trees is approximately 200 pounds per acre per year and primarily occurs between March (when the trees start to bloom) and November (when the trees start to go dormant). Based on current wastewater flows of 41,000 gpd and the average total nitrogen concentration of 53 mg/L, the current nitrogen loading is approximately 120 pounds per acre per year. Based on the proposed flow limit of 64,000 gpd, the nitrogen loading rate would be approximately 188 pounds per acre per

year. If the nitrogen load reaches 90 percent of the annual demand, the Discharger will plant a cover crop, such as perennial ryegrass, to ensure nitrogen overloading does not occur. The annual nitrogen demand for perennial ryegrass is 150 pounds per acre.

24. Residual solids from the blanching process are primarily almond skins, which are conveyed out of the blancher building directly into truck bins to be hauled away and sold as animal feed
25. Storm water runoff from the process buildings is conveyed to Pond 3 for disposal by evaporation and percolation. Pond 3 is adjacent to Pond 2 and has the same dimensions as Pond 2. Storm water is not discharged into Pond 2 and process wastewater is not discharged into Pond 3.

Site-Specific Conditions

26. The site is relatively level at an elevation of approximately 140 feet above mean sea level (MSL). Surface water drainage is generally south to north toward the Tuolumne River, which is approximately 0.75 miles north of the facility.
27. The average annual precipitation is 12.3 inches and the 100-year, 365-day return total is 21.0 inches. The normal-year evapotranspiration is approximately 53.4 inches per year.
28. Based on the 26 September 2008 Flood Insurance Rate Map, the facility is located in an area determined to be outside the one percent annual chance (or 100-year) flood zone.
29. The facility lies within the Turlock subbasin, which includes consolidated and unconsolidated sedimentary deposits. The unconsolidated deposits include continental deposits, older alluvium, younger alluvium, and flood basin deposits. Lacustrine and marsh deposits, which constitute the Corcoran aquitard, underlie the western half of the subbasin at approximate depths ranging from 50 to 200 feet. The consolidated deposits lie in the eastern portion of the subbasin and include the Lone Formation of Miocene Age, the Valley Springs Formation of Eocene Age, and the Mehrten Formation that was deposited during the Miocene to Pliocene Epochs.
30. Monitoring well boring logs at the facility indicate that soils in the first 20 feet below ground surface (bgs) include 10 feet of fine to very coarse sand, 5 feet of fine to coarse sand with a lens of iron-cemented silt, silty clay, and clay. Layers of fine to very coarse sand, clayey sand, clay, sandy clay, and silty clay exist for the following 80 feet bgs.
31. Surrounding land uses are primarily agricultural with some residences. The Discharger states that local crops are primarily almond orchards that use groundwater and Turlock Irrigation District water for irrigation.
32. Domestic wastewater generated at the facility is discharged to a septic system southwest of the existing facility building, which is regulated by Stanislaus County.

Groundwater Conditions

33. In January 2011 the Discharger installed three groundwater monitoring wells (MW-1, MW-2, and MW-3) at the site to monitor shallow groundwater and has performed quarterly monitoring. The depth to groundwater is typically 70 to 85 feet below ground surface and groundwater flows toward the east with a gradient that ranges from 0.0009 to 0.0019. Based on the groundwater gradient, MW-1 is downgradient of Pond 2, Pond 3, and the LAA. MW-2 is spatially upgradient of Pond 2 but is likely influenced by percolation from Pond 2. MW-3 was intended to monitor background groundwater quality but the proposed land application area was changed and now encompasses MW-3. Because the facility does not have an adequate groundwater monitoring well network, this Order requires the Discharger to install an additional monitoring well and evaluate background groundwater quality.
34. Groundwater samples were analyzed for key constituents in January 2011. Since then, pH and total dissolved solids (TDS) have been analyzed quarterly. Groundwater monitoring results are summarized in the following table:

Constituent	Units	MW-1	MW-2	MW-3	Potential WQO
pH ¹	S.U.	6.4 (5.9 - 6.9)	7.0 (6.7 - 7.5)	7.2 (6.6 - 7.7)	6.5 - 8.5 ³
TDS ¹	mg/L	403 (350-440)	638 (580-700)	459 (420-500)	450 ⁵ - 1,500 ³
Nitrate (as N) ²	mg/L	15.8	28.4	15.0	10 ⁴
Chloride ²	mg/L	15	25	19	106 ⁵ - 600 ³
Sodium ²	mg/L	37	50	132	69 ⁵
Boron ²	mg/L	0.05	0.09	< 0.1	0.7 ⁵
Iron ²	mg/L	< 0.05	< 0.05	< 0.05	0.3 ³
Manganese ²	mg/L	0.0132	0.0057	0.02	0.05 ³
Potassium ²	mg/L	3	4	4	--

¹ Average and range of data collected quarterly from January 2011 through May 2013.

² Single sample collected in January 2011 after the monitoring wells were installed.

³ Secondary Maximum Contaminant Level

⁴ Primary Maximum Contaminant Level

⁵ Lowest agricultural water quality goal

35. Without background groundwater monitoring data it is not possible to definitively evaluate whether degradation has occurred or the extent of degradation. The following preliminary assessment of groundwater degradation is based on available monitoring data but is not conclusive:
- a. MW-2 data indicate that Pond 2 may be causing groundwater degradation with respect to TDS but not exceedance of the water quality objective. MW-2 data also indicates that the discharge may have caused or contributed to localized nitrate pollution.

- b. Monitoring well MW-1 data indicate that infiltration from the storm water pond (Pond 3) may dilute groundwater TDS concentrations as groundwater travels from MW-2 to MW-1. MW-1 data also show the pH concentration is, at times, below the lower MCL of 6.5. It is not clear whether the low pH concentration is naturally occurring or is caused by Pond 2, Pond 3, or acidic leachate associated with temporary storage of almond hulls by the neighboring hulling company.

Basin Plan, Beneficial Uses, and Regulatory Considerations

36. The *Water Quality Control Plan for the Sacramento River and San Joaquin River Basins*, Fourth Edition (hereafter Basin Plan) designates beneficial uses, establishes water quality objectives, contains implementation plans and policies for protecting waters of the basin, and incorporates by reference plans and policies adopted by the State Water Board. Pursuant to Water Code section 13263(a), waste discharge requirements must implement the Basin Plan.
37. Local drainage is to Tuolumne River. The beneficial uses of Tuolumne River, as stated in the Basin Plan, are municipal and domestic supply; agricultural supply; water contact recreation; non-contact water recreation; warm freshwater habitat; cold freshwater habitat; wildlife habitat; migration of aquatic organisms; and spawning, reproduction, and/or early development.
38. The beneficial uses of underlying groundwater as set forth in the Basin Plan are municipal and domestic supply, agricultural supply, industrial service supply and industrial process supply.
39. The Basin Plan establishes narrative water quality objectives for chemical constituents, tastes and odors, and toxicity in groundwater. It also sets forth a numeric objective for total coliform organisms.
40. The Basin Plan's numeric water quality objective for bacteria requires that the most probable number (MPN) of coliform organisms over any seven-day period shall be less than 2.2 per 100 mL in MUN groundwater.
41. The Basin Plan's narrative water quality objectives for chemical constituents, at a minimum, require waters designated as domestic or municipal supply to meet the MCLs specified in Title 22 of the California Code of Regulations (hereafter Title 22). The Basin Plan recognizes that the Central Valley Water Board may apply limits more stringent than MCLs to ensure that waters do not contain chemical constituents in concentrations that adversely affect beneficial uses.
42. The narrative toxicity objective requires that groundwater be maintained free of toxic substances in concentrations that produce detrimental physiological responses in human, animal, plant, or aquatic life associated with designated beneficial uses.

43. Quantifying a narrative water quality objective requires a site-specific evaluation of those constituents that have the potential to impact water quality and beneficial uses. The Basin Plan states that when compliance with a narrative objective is required to protect specific beneficial uses, the Central Valley Water Board will, on a case-by-case basis, adopt numerical limitations in order to implement the narrative objective.
44. In the absence of specific numerical water quality limits, the Basin Plan methodology is to consider any relevant published criteria. General salt tolerance guidelines, such as *Water Quality for Agriculture* by Ayers and Westcot and similar references indicate that yield reductions in nearly all crops are not evident when irrigation water has an EC less than 700 $\mu\text{mhos/cm}$. There is, however, an eight- to ten-fold range in salt tolerance for agricultural crops and the appropriate salinity values to protect agriculture in the Central Valley are considered on a case-by-case basis. It is possible to achieve full yield potential with waters having EC up to 3,000 $\mu\text{mhos/cm}$ if the proper leaching fraction is provided to maintain soil salinity within the tolerance of the crop.
45. The list of crops in Finding 30 is not intended as a definitive inventory of crops that are or could be grown in the area affected by the discharge, but it is representative of current and historical agricultural practices in the area.

Antidegradation Analysis

46. State Water Resources Control Board Resolution 68-16 ("Policy with Respect to Maintaining High Quality Waters of the State") (hereafter Resolution 68-16) prohibits degradation of groundwater unless it has been shown that:
 - a. The degradation is consistent with the maximum benefit to the people of the state.
 - b. The degradation will not unreasonably affect present and anticipated future beneficial uses.
 - c. The degradation does not result in water quality less than that prescribed in state and regional policies, including violation of one or more water quality objectives, and
 - d. The discharger employs best practicable treatment or control (BPTC) to minimize degradation.
47. Degradation of groundwater by some of the typical waste constituents associated with discharges from a food processing facility, after effective source control, treatment, and control measures are implemented, is consistent with the maximum benefit to the people of the state. The Discharger's operation employs up to 150 people during the peak season of processing. The economic prosperity of valley communities and associated industry is of maximum benefit to the people of the State, and provides sufficient justification for allowing the limited groundwater degradation that may occur pursuant to this Order.

48. The Discharger has been monitoring groundwater quality at the site since 2011. The California Department of Water Resources' (DWR) Water Quality Library indicates one well, station name 04S10E11J001M, that is close to the facility and has been monitored for ground water quality. The well was monitored once in December 1949 using an unknown analytical method and results were as follows: 0.16 mg/L boron; 21 mg/L chloride; 160 µmhos/cm electrical conductivity; 0.7 mg/L magnesium; and 46 mg/L sodium. The DWR states that unknown analytical methods may not compare with modern data.
49. Based on the data available, it is not possible to determine pre-1968 groundwater quality. Therefore, determination of compliance with Resolution 68-16 for this facility must be based on existing background groundwater quality. As stated previously, background quality cannot yet be determined due to an inadequate groundwater monitoring well network.
50. Constituents of concern that have the potential to degrade groundwater include salts (primarily TDS), nutrients, and pH as discussed below:
 - a. **Total Dissolved Solids (TDS).** After 25 years of operation, the groundwater degradation indicated in MW-2 is minor, so further control to reduce TDS does not appear necessary at this time. Because of evapotranspiration, the discharge has the potential to degrade groundwater quality, but should not cause exceedance of a water quality objective. This Order sets an FDS effluent limit of 500 mg/L as a flow-weighted annual average based on the limited characterization of wastewater to date with an allowance for reasonable uncertainty and a groundwater limitation that prohibits exceedance of a water quality objective.
 - b. **Nitrate.** For nutrients such as nitrate, the potential for groundwater degradation depends on wastewater quality; crop uptake, and the ability of the vadose zone below the LAAs to support nitrification and denitrification to convert the nitrogen to nitrogen gas before it reaches the water table. Most of the nitrogen in the process wastewater is present as total Kjeldahl nitrogen (TKN), which can readily mineralize and convert to nitrate (with some loss via ammonia volatilization) in the LAAs. The total nitrogen concentration of the wastewater has the potential to degrade groundwater but it cannot be determined whether the discharge has caused exceedance of the water quality objective or background quality. Based on the limited data available, it appears that background groundwater quality exceeds the primary MCL of 10 mg/L due to surrounding agricultural practices. Based on data from MW-2, the use of unlined Pond 2 maybe causing or contributing to an exceedance of the MCL for nitrate nitrogen. The current nitrogen loading rate to the LAA is currently less than the nitrogen needs of the almonds. An increase in wastewater flow may reduce treatment capacity and cause nitrogen overloading to the LAA.

This Order requires that nutrients associated with the wastewater and other sources be applied to the LAAs at rates consistent with crop demand, and requires the

Discharger to submit a *Groundwater Quality Study* after eight quarters of data have been collected from new monitoring wells. If the report indicates that the discharge to either Pond 2 or the LAAs is causing or contributing to pollution, then further treatment or control will be required, which may include lining Pond 2. The Groundwater Limitations of this Order require that the discharge not cause groundwater to exceed background groundwater quality or the Water Quality Objective, whichever is greater.

- c. **pH.** Monitoring data from MW-1 indicate that an unknown source may have caused pH in groundwater to be lower than the secondary MCL minimum. At this time, there is no reason to believe that the discharge has caused or contributed to the low pH in MW-1. If future monitoring indicates a significant pH problem that can be attributed to the discharge regulated under this Order, additional action such as source control may be required.

51. This Order establishes effluent and groundwater limitations for the facility that will not unreasonably threaten present and anticipated beneficial uses or result in groundwater quality that exceeds water quality objectives set forth in the Basin Plan.

- a. For TDS, groundwater monitoring data indicate that groundwater has been degraded by the discharge, but the degradation has not caused exceedance of a water quality objective. This Order requires the Discharger to implement BPTC, so the degradation is allowable under Resolution 68-16.
- b. For nitrate, groundwater monitoring data indicate exceedance of a water quality objective but it is not clear whether the discharge is causing the exceedance. The provisions of this Order require that the Discharger implement BPTC so that the discharge does not cause exceedance of a water quality objective or the background groundwater quality, whichever is greater.

52. The Discharger provides treatment and control of the discharge that incorporates:

- a. Use of high quality water for source water and supplemental irrigation, which reduces percolate salinity.
- b. Disposing of boiler precipitate at a landfill to reduce constituent concentrations in the wastewater.
- c. Screening the wastewater prior to discharge to reduce BOD and nitrogen.
- d. Approximately 55 acres of LAAs are available. Crops are grown on the LAAs and will take up the nutrients found in the wastewater if wastewater application rates are carefully controlled.

53. This Order requires implementation of upgrades and any additional measures that will be required to comply with the Groundwater Limitations of this Order. This Order

imposes effluent and mass loading rate limitations and contains provisions to implement additional treatment or control to ensure that the highest water quality consistent with the maximum benefit to the people of the State will be achieved while minimizing any degradation that may occur pending completion of the required tasks. This Order sets a numeric trigger concentration for TDS in groundwater that is below the groundwater limitation. If the trigger concentration is exceeded in a compliance monitoring well, this order requires that the Discharger either demonstrate that the increasing trend will not result in exceedance of the groundwater limitation or implement additional treatment or control to ensure compliance with the groundwater limitation. Following completion of additional groundwater studies, this Order will be reopened if necessary to reconsider effluent limitations and other requirements to comply with Resolution 68-16. Based on the existing record, the discharge authorized by this Order is consistent with the antidegradation provisions of Resolution 68-16.

Other Regulatory Considerations

54. In compliance with Water Code section 106.3, it is the policy of the State of California that every human being has the right to safe, clean, affordable, and accessible water adequate for human consumption, cooking, and sanitary purposes. This order promotes that policy by requiring discharges to meet maximum contaminant levels designed to protect human health and ensure that water is safe for domestic use.
55. Based on the threat and complexity of the discharge, the facility is determined to be classified as 2B as defined below:
 - a. Category 2 threat to water quality: "Those discharges of waste that could impair the designated beneficial uses of the receiving water, cause short-term violations of water quality objectives, cause secondary drinking water standards to be violated, or cause a nuisance."
 - b. Category B complexity, defined as: "Any discharger not included [as Category A] that has physical, chemical, or biological treatment systems (except for septic systems with subsurface disposal) or any Class 2 or Class 3 waste management units."
56. Title 27 of the California Code of Regulations (hereafter Title 27) contains regulatory requirements for the treatment, storage, processing, and disposal of solid waste. However, Title 27 exempts certain activities from its provisions. Discharges regulated by this Order are exempt from Title 27 pursuant to provisions that exempt domestic sewage, wastewater, and reuse. Title 27, section 20090 states in part:

The following activities shall be exempt from the SWRCB-promulgated provisions of this subdivision, so long as the activity meets, and continues to meet, all preconditions listed:

(...)

(b) Wastewater - Discharges of wastewater to land, including but not limited to evaporation ponds, percolation ponds, or subsurface leachfields if the following conditions are met:

- (1) the applicable RWQCB has issued WDRs, reclamation requirements, or waived such issuance;
- (2) the discharge is in compliance with the applicable water quality control plan; and
- (3) the wastewater does not need to be managed according to Chapter 11, Division 4.5, Title 22 of this code as a hazardous waste.

57. The discharge authorized herein, and the treatment and storage facilities associated with the discharge, are exempt from the requirements of Title 27. The current unlined wastewater ponds, future aerated ponds and LAAs are exempt pursuant to Title 27, section 20090(b) because they are discharges of wastewater to land and:

- a. The Central Valley Water Board is issuing WDRs;
- b. This Order prescribes requirements that will ensure compliance with the Basin Plan; and
- c. The wastewater discharged to the LAAs does not need to be managed as hazardous waste.

58. The U.S. EPA published *Statistical Analysis of Groundwater Monitoring Data at RCRA Facilities, Unified Guidance* (hereafter "Unified Guidance") in 2009. As stated in the Unified Guidance, the document:

...[Unified Guidance] is tailored to the context of the RCRA groundwater monitoring regulations ...[however, t]here are enough commonalities with other regulatory groundwater monitoring programs ... to allow for more general use of the tests and methods in the Unified Guidance... Groundwater detection monitoring involves either a comparison between different monitoring stations ... or a contrast between past and present data within a given station... The Unified Guidance also details methods to compare background data against measurements from regulatory compliance points ... [as well as] techniques for comparing datasets against fixed numerical standards ... [such as those] encountered in many regulatory programs.

59. The statistical data analysis methods in the Unified Guidance are appropriate for determining whether the discharge complies with Groundwater Limitations of this Order.

60. The State Water Board adopted Order 97-03-DWQ (NPDES General Permit CAS000001) specifying waste discharge requirements for discharges of storm water associated with industrial activities, and requiring submittal of a Notice of Intent by all affected industrial dischargers. The Discharger retains all storm water onsite and is not required to obtain coverage under State Water Board's Water Quality Order 97-03-DWQ.

61. Water Code section 13267(b) states:

In conducting an investigation specified in subdivision (a), the regional board may require that any person who has discharged, discharges, or is suspected of discharging, or who proposes to discharge within its region ... shall furnish, under penalty of perjury, technical or monitoring program reports which the board requires. The burden, including costs of these reports, shall bear a reasonable relationship to the need for the reports and the benefits to be obtained from the reports. In requiring those reports, the regional board shall provide the person with a written explanation with regard to the need for the reports, and shall identify the evidence that supports requiring that person to provide the reports.

The technical reports required by this Order and the attached Monitoring and Reporting Program R5-2014-0059 are necessary to ensure compliance with these waste discharge requirements. The Discharger owns and operates the facility that discharges the waste subject to this Order.

62. The California Department of Water Resources sets standards for the construction and destruction of groundwater wells (hereafter DWR Well Standards), as described in *California Well Standards Bulletin 74-90* (June 1991) and *Water Well Standards: State of California Bulletin 94-81* (December 1981). These standards, and any more stringent standards adopted by the state or county pursuant to Water Code section 13801, apply to all monitoring wells used to monitor the impacts of wastewater storage or disposal governed by this Order.
63. The action to adopt waste discharge requirements for this existing facility is exempt from the provisions of the California Environmental Quality (CEQA), in accordance with the California Code of Regulations, title 14, section 15301.
64. The facility has been in operation since 1985 and the Central Valley Regional Water Board first became aware of the facility after Pond 2 and Pond 3 were constructed to segregate collected storm water from process wastewater.
65. The action of prescribing WDRs, which impose regulatory requirements on the existing discharge in order to ensure the protection of groundwater resources, is exempt from the provisions of the CEQA in accordance with California Code of Regulations, title 14, section 15301, which exempts the "operation, repair, maintenance, [and] permitting ... of existing public or private structures, facilities, mechanical equipment, or topographical features" from environmental review.
66. Pursuant to Water Code section 13263(g), discharge is a privilege, not a right, and adoption of this Order does not create a vested right to continue the discharge.

Public Notice

67. All the above and the supplemental information and details in the attached Information Sheet, which is incorporated by reference herein, were considered in establishing the following conditions of discharge.
68. The Discharger and interested agencies and persons have been notified of the Central Valley Water Board's intent to prescribe waste discharge requirements for this discharge, and they have been provided an opportunity to submit written comments and an opportunity for a public hearing.
69. All comments pertaining to the discharge were heard and considered in a public hearing.

IT IS HEREBY ORDERED that pursuant to Water Code sections 13263 and 13267, Hughson Nut, Inc., its agents, successors, and assigns, in order to meet the provisions contained in Division 7 of the Water Code and regulations adopted hereunder, shall comply with the following:

A. Discharge Prohibitions

1. Discharge of wastes to surface waters or surface water drainage courses, including irrigation ditches outside of control of the Discharger, is prohibited.
2. Discharge of waste classified as 'hazardous', as defined in the California Code of Regulations, title 23, section 2510 et seq., is prohibited.
3. Treatment system bypass of untreated or partially treated waste is prohibited, except as allowed by Standard Provision E.2 of the *Standard Provisions and Reporting Requirements for Waste Discharge Requirements*.
4. Discharge of waste at a location or in a manner different from that described in the Findings is prohibited.
5. Discharge of toxic substances into the wastewater treatment system or land application areas such that biological treatment mechanisms are disrupted is prohibited.
6. Application of residual solids to the land application areas is prohibited.
7. Discharge of process wastewater to the domestic wastewater treatment system (septic system) is prohibited.
8. Discharge of domestic wastewater to the process wastewater ponds, land application area or any surface waters is prohibited.

9. Discharge of process or domestic wastewater to the storm water basin (Pond 3) is prohibited.

B. Flow Limitations

1. Influent flows to the wastewater treatment system shall not exceed the following limits:

Flow Measurement	Flow Limit
Average Daily Flow ¹	64,000 gpd
Total Annual Flow ²	16.5 MG

¹ As determined by the total flow during the calendar month divided by the number of days in that month.

² As determined by the total flow for the calendar year.

C. Effluent and Mass Loading Limitations

1. The blend of treated wastewater, storm water, and supplemental irrigation water applied to the LAAs shall not exceed the following effluent and mass loading limits:

Constituent	Units	Cycle Average ¹	Annual Maximum
BOD Mass Loading	lb/ac/day	100	--
Average FDS Concentration	mg/L	--	500 ²
Total Nitrogen Mass Loading	lb/ac/year	--	Crop Demand

¹ This limit applies as irrigation cycle average for each LAA field. For the purpose of this Order, "irrigation cycle" is defined as the time period between the start of an irrigation event and the start of the next irrigation event on the same LAA field identified in Attachment B.

² Flow-weighted average based on total flow and concentration discharged.

2. Compliance with the above requirements shall be determined as specified below:

- a. The mass of BOD applied to each LAA field as an irrigation cycle average on a daily basis shall be calculated using the following formula:

$$M = \frac{8.345(C \cdot V)}{A \cdot CT}$$

Where: *M* = mass of BOD in lb/ac/day applied to each LAA field identified on Attachment B

C = concentration of BOD in mg/L based on most recent monitoring result

V = volume of wastewater applied to each LAA field in millions of gallons per day
 A = area of the LAA irrigated in acres
 CT = cycle time (i.e., irrigation cycle length)
 8.345 = unit conversion factor

- b. The mass of total nitrogen applied to each LAA field on an annual basis shall be calculated using the following formula and compared to published crop demand for the crops actually grown:

$$M = \sum_{i=1}^{12} \frac{(8.345(C_i \cdot V_i) + M_x)}{A}$$

Where: M = mass of nitrogen in lb/ac/yr applied to each LAA field identified on Attachment B
 C_i = Monthly average concentration of total nitrogen for month i in mg/L
 V_i = volume of wastewater applied to each LAA field during calendar month i in million gallons
 A = area of the LAA irrigated in acres
 i = the number of the month (e.g., January = 1, February = 2, etc.)
 M_x = nitrogen mass from other sources (e.g., fertilizer and compost) in pounds
 8.345 = unit conversion factor

- c. The flow-weighted average annual FDS concentration shall be calculated using the following formula:

$$C_a = \frac{\sum_{i=1}^{12} (C_i \times V_i)}{\sum_{i=1}^{12} (V_i)}$$

Where: C_a = Flow-weighted average annual FDS concentration in mg/L
 i = the number of the month (e.g., January = 1, February = 2, etc.)
 C_i = Monthly average process wastewater FDS concentration for calendar month i in mg/L
 V_i = volume of process wastewater applied to each LAA field during calendar month i in million gallons

D. Discharge Specifications

1. No waste constituent shall be released, discharged, or placed where it will be released or discharged, in a concentration or in a mass that causes violation of the Groundwater Limitations of this Order.
2. The discharge shall not cause degradation of any water supply.
3. Wastewater treatment, storage, and disposal shall not cause pollution or a nuisance as defined by Water Code section 13050.
4. The discharge shall remain within the permitted waste treatment/containment structures and land application areas at all times.
5. The Discharger shall operate all systems and equipment to optimize the quality of the discharge.
6. All conveyance, treatment, storage, and disposal systems shall be designed, constructed, operated, and maintained to prevent inundation or washout due to floods with a 100-year return frequency.
7. Objectionable odors shall not be perceivable beyond the limits of the property where the waste is generated, treated, and/or discharged at an intensity that creates or threatens to create nuisance conditions.
8. As a means of discerning compliance with Discharge Specification D.7, the dissolved oxygen (DO) content in the upper one foot of any wastewater pond shall not be less than 1.0 mg/L for three consecutive weekly sampling events. If the DO in any single pond is below 1.0 mg/L for three consecutive sampling events, the Discharger shall report the findings to the Regional Water Board in writing within 10 days and shall include a specific plan to resolve the low DO results within 30 days.
9. The Discharger shall operate and maintain all ponds sufficiently to protect the integrity of containment dams and berms and prevent overtopping and/or structural failure. Unless a California-registered civil engineer certifies (based on design, construction, and conditions of operation and maintenance) that less freeboard is adequate, the operating freeboard in any pond shall never be less than two feet (measured vertically from the lowest possible point of overflow). As a means of management and to discern compliance with this requirement, the Discharger shall install and maintain in each pond a permanent staff gauge with calibration marks that clearly show the water level at design capacity and enable determination of available operational freeboard.
10. Wastewater treatment, storage, and disposal ponds or structures shall have sufficient capacity to accommodate allowable wastewater flow, design seasonal

precipitation, and ancillary inflow and infiltration during the winter while ensuring continuous compliance with all requirements of this Order. Design seasonal precipitation shall be based on total annual precipitation using a return period of 100 years, distributed monthly in accordance with historical rainfall patterns.

11. On or about **1 October** of each year, available capacity shall at least equal the volume necessary to comply with Discharge Specifications D.9 and D.10.
12. All ponds and open containment structures shall be managed to prevent breeding of mosquitoes. Specifically:
 - a. An erosion control program shall be implemented to ensure that small coves and irregularities are not created around the perimeter of the water surface.
 - b. Weeds shall be minimized through control of water depth, harvesting, or herbicides.
 - c. Dead algae, vegetation, and debris shall not accumulate on the water surface.
 - d. The Discharger shall consult and coordinate with the local Mosquito Abatement District to minimize the potential for mosquito breeding as needed to supplement the above measures.
13. Newly constructed or rehabilitated berms or levees (excluding internal berms that separate ponds or control the flow of water within a pond) shall be designed and constructed under the supervision of a California Registered Civil Engineer.
14. Wastewater contained in any unlined pond shall not have a pH less than 6.0 or greater than 9.5.

E. Groundwater Limitations

Release of waste constituents from any portion of the facility shall not cause groundwater to:

1. Contain any of the specified constituents in a concentration statistically greater than the maximum allowable concentration tabulated below. **The wells to which these requirements apply are specified in the Monitoring and Report Program.**

Parameter	Units	Water Quality Objective	Allowable Concentration	Date Effective ¹
Nitrate nitrogen	mg/L	10	Background groundwater quality or the Water Quality Objective, whichever is greater	Immediately

¹ Applies only to the specific compliance monitoring wells listed in the Monitoring and Reporting Program.

2. Except as specified in Groundwater Limitation E.1 above, contain constituents in concentrations that exceed either the Primary or Secondary MCLs established in Title 22 of the California Code of Regulations.
3. Except as specified in Groundwater Limitation E.1 above, contain taste or odor-producing constituents, toxic substances, or any other constituents in concentrations that cause nuisance or adversely affect beneficial uses.

F. Land Application Area Specifications

1. Tailwater runoff and wastewater shall not be discharged outside of the LAAs.
2. Crops shall be grown in the LAAs and water application rates shall be consistent with crop needs.
3. Land application of wastewater shall be managed to minimize erosion.
4. The LAAs shall be managed to prevent breeding of mosquitoes. In particular:
 - a. There shall be no standing water 48 hours after irrigation ceases;
 - b. Tailwater ditches shall be maintained essentially free of emergent, marginal, and floating vegetation; and
 - c. Low-pressure and unpressurized pipelines and ditches accessible to mosquitoes shall not be used to store recycled water.
5. LAAs shall be designed, maintained, and operated to comply with the following setback requirements:

Setback Definition	Minimum Irrigation Setback (feet)
Edge of LAA to property boundary	25
Edge of LAA to manmade or natural surface water drainage course	25
Edge of LAA to domestic water supply well	100

6. Irrigation of the LAAs shall occur only when appropriately trained personnel are on duty.
7. LAAs shall be inspected as frequently as necessary to ensure continuous compliance with the requirements of this Order.
8. Spray irrigation with wastewater is prohibited when wind speed (including gusts) exceeds 30 mph.

9. Sprinkler heads shall be designed, operated and maintained to create a minimum amount of mist.
10. Any irrigation runoff (tailwater) shall be confined to the LAAs and shall not enter any surface water drainage course or storm water drainage system.
11. Discharge to the LAAs shall not be performed during rainfall or when the ground is saturated.
12. Discharge of storm water runoff from the LAAs to off-site land or surface water drainage courses is prohibited

G. Solids Disposal Specifications

Sludge, as used in this document, means the solid, semisolid, and liquid organic matter removed from wastewater treatment, settling, and storage vessels or ponds. Solid waste refers to solid inorganic matter removed by screens and soil sediments from washing of unprocessed fruit or vegetables. Except for waste solids originating from meat processing, residual solids means organic food processing byproducts such as culls, pulp, stems, leaves, and seeds that will not be subject to treatment prior to disposal or land application.

1. Sludge and solid waste shall be removed from screens, sumps, ponds, and clarifiers as needed to ensure optimal operation and adequate storage capacity.
2. The Discharger shall monitor sludge accumulation in the wastewater treatment/storage ponds at least every five years **beginning in 2015**, and shall periodically remove sludge as necessary to maintain adequate storage capacity. Specifically, if the estimated volume of sludge in the reservoir exceeds five percent of the permitted reservoir capacity, the Discharger shall complete sludge cleanout within 12 months after the date of the estimate.
3. Any handling and storage of sludge, solid waste, and residual solids shall be controlled and contained in a manner that minimizes leachate formation and precludes infiltration of waste constituents into soils in a mass or concentration that will violate the groundwater limitations of this Order.
4. If removed from the site, sludge, solid waste, and residual solids shall be disposed of in a manner approved by the Executive Officer and consistent with Title 27, division 2. Removal for reuse as animal feed, or land disposal at facilities (i.e., landfills, composting facilities, soil amendment sites) operated in accordance with valid waste discharge requirements issued by a Regional Water Board will satisfy this specification.
5. Any proposed change in solids use or disposal practice shall be reported in writing to the Executive Officer at least 90 days in advance of the change.

6. At least **180 days** prior to any sludge removal and disposal, the Discharger shall submit a *Sludge Cleanout Plan*. The plan shall include a detailed plan for sludge removal, drying, and disposal. The plan shall specifically describe the phasing of the project, measures to be used to control runoff or percolate from the sludge as it is drying, and a schedule that shows how all dried sludge will be land applied to the LAAs or removed from the site prior to the onset of the rainy season (**1 October**).

H. Provisions

1. The following reports shall be submitted pursuant to Water Code section 13267 and shall be prepared as described in Provision H.5:
 - a. By **1 July 2014**, the Discharger shall submit a *Groundwater Monitoring Well Installation Workplan* that proposes a new background monitoring well to ensure adequate monitoring upgradient of all wastewater ponds as well as the land application area. The workplan shall be prepared in accordance with, and include the items listed in, the first section of Attachment D: "Requirements for Monitoring Well Installation Workplans and Monitoring Well Installation Reports", which is attached hereto and made part of this Order by reference. The groundwater monitoring well shall be designed to yield samples representative of the uppermost portion of the first aquifer underlying the ponds and land application area.
 - b. By **1 September 2014**, the Discharger shall submit a *Flow Meter Installation Report*. The report shall describe the installation of a flow meter to monitor effluent flows at the locations shown schematically on Attachment C. The report shall specify the flow meter type, actual location, and certify that the flow meters have been calibrated and are working properly.
 - c. By **1 November 2014**, the Discharger shall submit a *Groundwater Monitoring Well Installation Report* for any new groundwater monitoring wells constructed to comply with Provision H.1.a. The report shall be prepared in accordance with, and include the items listed in, the second section of Attachment D: "Monitoring Well Workplan and Monitoring Well Installation Report Guidance". The report shall describe the installation and development of all new monitoring wells, and explain any deviation from the approved workplan.
 - d. By **1 February 2017**, the Discharger shall submit a *Groundwater Quality Study*. For each groundwater monitoring parameter/constituent identified in the MRP, the report shall:
 - i. Present a summary of all historical groundwater monitoring data and determination of background groundwater quality. Determination of background quality shall be made using statistics selected in accordance with the U.S. EPA Unified Guidance document cited in Finding 57, and shall be based on data from at least eight consecutive quarterly (or more frequent) groundwater monitoring events.

- ii. Describe and justify the statistical methods proposed to evaluate compliance with Groundwater Limitation E.1, E.2, and E.3 of this Order for the specified compliance wells and constituents. Compliance shall be determined using appropriate statistical methods that have been selected based on site-specific information and the U.S. EPA Unified Guidance document cited in Finding 57 of this Order. The report shall explain and justify the selection of the appropriate statistical methods.
 - iii. Evaluate whether the discharge is causing groundwater degradation (i.e., a concentration statistically greater than background water quality) and/or exceedance of the water quality objective. Where background concentrations are statistically greater than the limitations specified in Groundwater Limitation E.1, the report shall recommend final groundwater limitations which comply with Resolution No. 68-16 for the waste constituents listed therein.
2. If groundwater monitoring results show that the discharge of waste is causing groundwater to contain any waste constituents in concentrations statistically greater than the Groundwater Limitations of this Order, within 120 days of the request of the Executive Officer, the Discharger shall submit a BPTC Evaluation Workplan that sets forth the scope and schedule for a systematic and comprehensive technical evaluation of each component of the facility's waste treatment and disposal system to determine best practicable treatment and control for each waste constituent that exceeds a Groundwater Limitation. The workplan shall contain a preliminary evaluation of each component of the WWTF and effluent disposal system and propose a time schedule for completing the comprehensive technical evaluation. The schedule to complete the evaluation shall be as short as practicable, and shall not exceed one year.
3. A discharger whose waste flow has been increasing, or is projected to increase, shall estimate when flows will reach hydraulic and treatment capacities of its treatment, collection, and disposal facilities. The projections shall be made in January, based on the last three years' average dry weather flows, peak wet weather flows and total annual flows, as appropriate. When any projection shows that capacity of any part of the facilities may be exceeded in four years, the discharger shall notify the Central Valley Water Board by **31 January**.
4. In accordance with California Business and Professions Code sections 6735, 7835, and 7835.1, engineering and geologic evaluations and judgments shall be performed by or under the direction of registered professionals competent and proficient in the fields pertinent to the required activities. All technical reports specified herein that contain workplans for investigations and studies, that describe the conduct of investigations and studies, or that contain technical conclusions and recommendations concerning engineering and geology shall be prepared by or under the direction of appropriately qualified professional(s), even if not explicitly stated. Each technical report submitted by the Discharger shall bear the professional's signature and stamp.

5. The Discharger shall submit the technical reports and work plans required by this Order for consideration by the Executive Officer, and incorporate comments the Executive Officer may have in a timely manner, as appropriate. Unless expressly stated otherwise in this Order, the Discharger shall proceed with all work required by the foregoing provisions by the due dates specified.
6. The Discharger shall comply with Monitoring and Reporting Program R5-2014-0059, which is part of this Order, and any revisions thereto as ordered by the Executive Officer. The submittal dates of Discharger self-monitoring reports shall be no later than the submittal date specified in the MRP.
7. The Discharger shall comply with the "Standard Provisions and Reporting Requirements for Waste Discharge Requirements", dated 1 March 1991, which are attached hereto and made part of this Order by reference. This attachment and its individual paragraphs are commonly referenced as "Standard Provision(s)."
8. The Discharger shall comply with all conditions of this Order, including timely submittal of technical and monitoring reports. On or before each report due date, the Discharger shall submit the specified document to the Central Valley Water Board or, if appropriate, a written report detailing compliance or noncompliance with the specific schedule date and task. If noncompliance is being reported, then the Discharger shall state the reasons for such noncompliance and provide an estimate of the date when the Discharger will be in compliance. The Discharger shall notify the Central Valley Water Board in writing when it returns to compliance with the time schedule. Violations may result in enforcement action, including Central Valley Water Board or court orders requiring corrective action or imposing civil monetary liability, or in revision or rescission of this Order.
9. The Discharger shall at all times properly operate and maintain all facilities and systems of treatment and control (and related appurtenances) that are installed or used by the Discharger to achieve compliance with the conditions of this Order. Proper operation and maintenance also includes adequate laboratory controls and appropriate quality assurance procedures. This provision requires the operation of back-up or auxiliary facilities or similar systems that are installed by the Discharger when the operation is necessary to achieve compliance with the conditions of this Order.
10. The Discharger shall use the best practicable cost-effective control technique(s) including proper operation and maintenance, to comply with this Order.
11. As described in the Standard Provisions, the Discharger shall report promptly to the Central Valley Water Board any material change or proposed change in the character, location, or volume of the discharge.
12. The Discharger shall report to the Central Valley Water Board any toxic chemical release data it reports to the State Emergency Response Commission within 15 days

of reporting the data to the Commission pursuant to section 313 of the "Emergency Planning and Community Right to Know Act of 1986."

13. The Discharger shall not allow pollutant-free wastewater to be discharged into the wastewater collection, treatment, and disposal systems in amounts that significantly diminish the system's capability to comply with this Order. Pollutant-free wastewater means rainfall, groundwater, cooling waters, and condensates that are essentially free of pollutants.
14. At least **90 days** prior to termination or expiration of any lease, contract, or agreement involving disposal or recycling areas or off-site reuse of effluent, used to justify the capacity authorized herein and assure compliance with this Order, the Discharger shall notify the Central Valley Water Board in writing of the situation and of what measures have been taken or are being taken to assure full compliance with this Order.
15. In the event of any change in control or ownership of the facility, the Discharger must notify the succeeding owner or operator of the existence of this Order by letter, a copy of which shall be immediately forwarded to the Central Valley Water Board.
16. To assume operation as Discharger under this Order, the succeeding owner or operator must apply in writing to the Executive Officer requesting transfer of the Order. The request must contain the requesting entity's full legal name, the state of incorporation if a corporation, the name and address and telephone number of the persons responsible for contact with the Central Valley Water Board, and a statement. The statement shall comply with the signatory paragraph of Standard Provision B.3 and state that the new owner or operator assumes full responsibility for compliance with this Order. Failure to submit the request shall be considered a discharge without requirements, a violation of the Water Code. If approved by the Executive Officer, the transfer request will be submitted to the Central Valley Water Board for its consideration of transferring the ownership of this Order at one of its regularly scheduled meetings.
17. A copy of this Order including the MRP, Information Sheet, Attachments, and Standard Provisions, shall be kept at the discharge facility for reference by operating personnel. Key operating personnel shall be familiar with its contents.
18. The Central Valley Water Board will review this Order periodically and will revise requirements when necessary.

If, in the opinion of the Executive Officer, the Discharger fails to comply with the provisions of this Order, the Executive Officer may refer this matter to the Attorney General for judicial enforcement, may issue a complaint for administrative civil liability, or may take other enforcement actions. Failure to comply with this Order or with the WDRs may result in the assessment of Administrative Civil Liability of up to \$10,000 per violation, per day, depending

on the violation, pursuant to the Water Code, including sections 13268, 13350 and 13385. The Central Valley Water Board reserves its right to take any enforcement actions authorized by law.

Any person aggrieved by this action of the Central Valley Water Board may petition the State Water Board to review the action in accordance with Water Code section 13320 and California Code of Regulations, title 23, sections 2050 and following. The State Water Board must receive the petition by 5:00 p.m., 30 days after the date of this Order, except that if the thirtieth day following the date of this Order falls on a Saturday, Sunday, or state holiday, the petition must be received by the State Water Board by 5:00 p.m. on the next business day. Copies of the law and regulations applicable to filing petitions may be found on the Internet at:

http://www.waterboards.ca.gov/public_notices/petitions/water_quality

or will be provided upon request.

I, PAMELA C. CREEDON, Executive Officer, do hereby certify that the foregoing is a full true and correct copy of an Order adopted by the California Regional Water Quality Control Board on 28 March 2014.

Original signed by _____
PAMELA C. CREEDON, Executive Officer

CALIFORNIA REGIONAL WATER QUALITY CONTROL BOARD
CENTRAL VALLEY REGION

MONITORING AND REPORTING PROGRAM R5-2014-0059

FOR
HUGHSON NUT, INC.
VERDUGA ROAD FACILITY
STANISLAUS COUNTY

This Monitoring and Reporting Program (MRP) describes requirements for monitoring the ponds, wastewater flow, wastewater quality, land application area, groundwater, and residual solids. This MRP is issued pursuant to Water Code section 13267. The Discharger shall not implement any changes to this MRP unless and until a revised MRP is issued by the Executive Officer.

Central Valley Water Board staff shall approve specific sampling locations prior to any sampling activities. All samples shall be representative of the volume and nature of the discharge. The time, date, and location of each grab sample shall be recorded on the sample chain of custody form.

Field test instruments (such as those used to test pH and electrical conductivity) may be used provided that:

1. The operator is trained in proper use and maintenance of the instruments;
2. The instruments are calibrated prior to monitoring event;
3. Instruments are serviced and/or calibrated by the manufacturer at the recommended frequency; and
4. Field calibration reports are submitted as described in the "Reporting" section of this MRP.

Analytical procedures shall comply with the methods and holding times specified in the following: *Methods for Organic Chemical Analysis of Municipal and Industrial Wastewater* (EPA); *Test Methods for Evaluating Solid Waste* (EPA); *Methods for Chemical Analysis of Water and Wastes* (EPA); *Methods for Determination of Inorganic Substances in Environmental Samples* (EPA); *Standard Methods for the Examination of Water and Wastewater* (APHA/AWWA/WEF); and *Soil, Plant and Water Reference Methods for the Western Region* (WREP 125). Approved editions shall be those that are approved for use by the United States Environmental Protection Agency or the California Department of Public Health's Environmental Laboratory Accreditation Program. The Discharger may propose alternative methods for approval by the Executive Officer. Where technically feasible, laboratory reporting limits shall be lower than the applicable water quality objectives for the constituents to be analyzed.

POND MONITORING

Ponds 1 and 2 shall be monitored in accordance with the following schedule. If the ponds are dry the monitoring report shall so note. Dissolved oxygen monitoring applies to any wastewater pond containing more than one foot of standing water

Constituent	Units	Type of Sample	Monitoring Frequency	Reporting Frequency
Dissolved oxygen ¹	mg/L	Grab	Weekly	Monthly
Freeboard	0.1 feet	Measurement	Weekly	Monthly
Odors	--	Observation	Weekly	Monthly
Berm/levee condition	--	Observation	Monthly	Monthly

¹ Samples shall be collected at a depth of one foot from each pond in use, opposite the inlet.

FLOW MONITORING

The Discharger shall monitor wastewater flows, and wastewater and supplemental irrigation water flows discharged to each LAA field as follows. **Effective immediately**, flows from Pond 1 and Pond 2 shall be based on supply well flows. **Effective 1 September 2014**, flows from Pond 1 and Pond 2 shall be determined using flow meters installed pursuant to Provision H.1.b:

Flow Source	Units	Type of Measurement	Monitoring Frequency	Reporting Frequency
Pond 1	gallons	Meter	Daily ¹	Monthly
Pond 2	gallons	Meter	Daily ¹	Monthly
Supplemental irrigation (On-site groundwater well)	gallons	Meter	Daily ¹	Monthly
Supplemental irrigation (TID)	gallons	Calculation	Daily ¹	Monthly
Total discharge to LAA	gallons and inches	Calculation	Daily ²	Monthly

¹ Report as total daily flow from the flow source to each LAA field.

² Includes all wastewater and supplemental irrigation water discharged to the LAAs.

WASTEWATER MONITORING

Wastewater samples shall be collected from the effluent sampling location as shown on Attachment C and shall be representative of wastewater from the Pond 2 prior to discharge to the land application areas. Sampling is not required during periods when no wastewater is discharged to the land application areas. At a minimum, wastewater monitoring shall include the following:

Constituents	Units	Type of Sample	Monitoring Frequency	Reporting Frequency
pH	Standard Units	Grab	Every 2 weeks	Monthly
BOD ₅ ¹	mg/L	Grab	Every 2 weeks	Monthly
FDS	mg/L	Grab	Every 2 weeks	Monthly
Total nitrogen	mg/L	Grab	Every 2 weeks	Monthly

BOD denotes Biochemical oxygen demand. FDS denotes Fixed dissolved solids.

¹ 5-day, 20 degrees Celsius biochemical oxygen demand.

LAND APPLICATION AREA MONITORING

The Discharger shall monitor the land application area **daily during operation**, and shall submit the results in the corresponding monthly monitoring reports. Evidence of erosion, field saturation, runoff, or the presence of nuisance conditions shall be noted in the report. The report shall also document any corrective actions taken based on observations made.

The Discharger shall perform the following routine monitoring and loading calculations for each LAA field during all months when land application occurs, and shall present the data in the Monthly and Annual Monitoring Reports. If irrigation does not occur during a reporting period, the monitoring report shall so indicate.

Constituent	Units	Type of Sample	Monitoring Frequency	Reporting Frequency
Precipitation	0.1 in.	Rain gauge ¹	Daily	Monthly
Hydraulic loading rate (from each source)	Inches	Calculated ^{2,5}	Daily	Monthly
Cycle average BOD ₅ loading rate	lb/ac	Calculated ^{2,3}	Daily	Monthly
Total nitrogen loading rate (including commercial fertilizers)	lb/ac	Calculated ^{2,4}	Monthly	Monthly

¹ Data obtained from the nearest National Weather Service, California Irrigation Management Information System (CIMIS), or on-site rain gauge is acceptable.

² Rate shall be calculated for each LAA field.

³ BOD₅ shall be calculated using the applied volume of wastewater, actual application area, and the most recent wastewater BOD₅ result.

⁴ Total nitrogen loading rates shall be calculated using the applied volume of wastewater, actual application area, and the most recent wastewater total nitrogen result plus loading rates for supplemental nitrogen calculated using the actual load and application area.

⁵ **Effective immediately**, flows from Pond 1 and Pond 2 shall be based on supply well flows. **Effective 1 September 2014**, flows from Pond 2 shall be determined using the flow meter installed pursuant to Provision H.1.b.

At least **once per week** when wastewater is being applied to the land application areas, the application areas in use shall be inspected to identify any equipment malfunction or other circumstance that might allow irrigation runoff to leave the area and/or create ponding conditions that violate the Waste Discharge Requirements. A log of these inspections shall be kept at the facility and summarized for submittal with the monthly monitoring reports.

APPLICABILITY OF GROUNDWATER LIMITATIONS

Prior to construction and/or sampling of any groundwater monitoring wells, the Discharger shall submit plans and specifications to the Central Valley Water Board for review and approval. Once installed, all new wells shall be added to the compliance monitoring network. The following table lists all existing monitoring wells and designates the purpose of each well.

MW1¹ MW2¹ MW3¹

¹ Compliance well.

The Groundwater Limitations set forth in Section E of the WDRs shall apply to the specific compliance monitoring wells tabulated below. This table is subject to revision by the Executive Officer following construction of any new compliance monitoring wells.

Constituent	Groundwater Limitation	Date Effective	Compliance Wells to which Limitation Applies
Nitrate nitrogen	Background groundwater quality or the Water Quality Objective, whichever is greater ¹	Immediately	All compliance wells
All Others	Contain constituents in concentrations that exceed either the Primary or Secondary MCLs.	Immediately	All compliance wells
All Others	Contain taste or odor-producing constituents, toxic substances, or any other constituents in concentrations that cause nuisance or adversely affect beneficial uses.	Immediately	All compliance wells

¹ Compliance with this requirement shall be determined on an intrawell basis for each of the specified wells using approved statistical methods.

GROUNDWATER MONITORING

Prior to sampling, depth to groundwater measurements shall be measured in each monitoring well to the nearest 0.01 feet. Groundwater elevations shall then be calculated to determine groundwater gradient and flow direction.

Low or no-purge sampling methods are acceptable, if described in an approved Sampling and Analysis Plan. Groundwater monitoring for all monitoring wells shall include, at a minimum, the following:

Constituent	Units	Type of Sample	Sampling Frequency	Reporting Frequency
Depth to groundwater	0.01 feet	Measurement	Quarterly	Quarterly
Groundwater elevation ¹	feet	Calculated	Quarterly	Quarterly

Constituent	Units	Type of Sample	Sampling Frequency	Reporting Frequency
Gradient magnitude	feet/feet	Calculated	Quarterly	Quarterly
Gradient direction	degrees	Calculated	Quarterly	Quarterly
pH	pH units	Grab	Quarterly	Quarterly
TDS	mg/L	Grab	Quarterly	Quarterly
TKN	mg/L	Grab	Quarterly	Quarterly
Nitrate nitrogen	mg/L	Grab	Quarterly	Quarterly
Total nitrogen	mg/L	Calculated	Quarterly	Quarterly
Standard minerals ²	mg/L	Grab	Quarterly for 6 consecutive events then Semiannually	Quarterly
Metals ^{3,4}	mg/L	Grab	Quarterly for 6 consecutive events then Semiannually	Quarterly

TDS denotes Total dissolved solids. TKN denotes Total Kjeldahl nitrogen.

¹ Groundwater elevation shall be determined based on depth-to-water measurements using a surveyed measuring point elevation on the well and surveyed reference elevation.

² Standard Minerals shall include, at a minimum, the following elements/compounds: boron, bromide, calcium, fluoride, magnesium, phosphate, potassium, sodium, sulfate, total alkalinity (including alkalinity series), and hardness as CaCO₃.

³ Samples for metals shall be filtered with a 0.45-micron filter prior to sample preservation. Analytical methods shall be selected to provide reporting limits below the Water Quality Limit for each constituent.

⁴ At a minimum, the following metals shall be included: arsenic, iron, manganese, nickel, and zinc.

Groundwater Trigger Concentrations

The following groundwater trigger concentrations are intended only to serve as a means of assessing whether the discharge might potentially cause a violation of one or more of the Groundwater Limitations of the WDRs at some later date.

Constituent	Compliance Wells	Trigger Concentration, mg/L
TDS	All compliance wells	800

If the annual evaluation of groundwater quality performed pursuant to this MRP shows that the annual average of one or more of the trigger concentrations has been exceeded in any compliance well during the calendar year, the Discharger shall submit one or both of the following technical reports by **1 May of the following calendar year** (e.g., if one or more trigger concentrations are exceeded for calendar year 2020, the appropriate report is due by **1 May 2021**):

- a. A technical evaluation of the reason[s] for the concentration increase[s] and a technical demonstration on a constituent-by-constituent that, although the concentration has increased more than expected in one or more compliance wells, continuing the discharge without additional treatment or control will not result in

exceedance of the applicable groundwater limitation.

- b. An Action Plan that presents a systematic technical evaluation of each component of the facility's waste treatment and disposal system to determine whether additional treatment or control is feasible for each waste constituent that exceeds a trigger concentration. The plan shall evaluate each component of the wastewater treatment, storage, and disposal system (as applicable); describe available treatment and/or control technologies; provide preliminary capital and operation/maintenance cost estimates for each; designate the preferred option[s] for implementation; and specify a proposed implementation schedule. The schedule for full implementation shall not exceed one year, and the Discharger shall immediately implement the proposed improvements.

RESIDUAL SOLIDS MONITORING

The Discharger shall monitor the residual solids generated and disposed of on a monthly basis. The following shall be monitored and reported:

1. Volume of solids generated. Solids may include hulls, shells, skins, screenings, sump solids, pond sludge, or other material.
2. Volume disposed of off-site. Describe the disposal method (e.g. animal feed, land application, off-site composting, landfill, etc.), the amount disposed (tons), and the name of the hauling company.
3. Where and how residual solids were stored on site. Describe the location and method of storage to comply with the Solids Disposal Specifications of the WDRs.

REPORTING

In reporting monitoring data, the Discharger shall arrange the data in tabular form so that the date, sample type (e.g., effluent, pond, etc.), and reported analytical result for each sample are readily discernible. The data shall be summarized in such a manner to clearly illustrate compliance with waste discharge requirements and spatial or temporal trends, as applicable. The results of any monitoring done more frequently than required at the locations specified in the Monitoring and Reporting Program shall be reported to the Central Valley Water Board.

As required by the California Business and Professions Code sections 6735, 7835, and 7835.1, all Groundwater Monitoring Reports shall be prepared under the direct supervision of a Registered Professional Engineer or Geologist and signed by the registered professional.

A. Monthly Monitoring Reports

Daily, weekly, and monthly monitoring data shall be reported in the monthly monitoring reports. Monthly reports shall be submitted to the Central Valley Water Board on the **1st day of the second month following sampling** (i.e. the January Report is due by

1 March). At a minimum, the reports shall include:

1. Tabulated pond monitoring data.
2. Tabulated daily flow measurements from Pond 1 to Pond 2, and from Pond 2 and supplemental irrigation water to each LAA field.
3. The cumulative annual wastewater flow from Pond 1 and Pond 2 to date, and the average daily wastewater flow for the month.
4. Tabulated wastewater monitoring data.
5. Tabulated land application area monitoring data for each LAA field, including; calculation of the hydraulic loading, cycle average BOD loading, and total nitrogen loading for the month and calendar year to date. The average of the three most recent monitoring results shall be used to determine cycle average BOD and total nitrogen loading. Loading rates for commercial fertilizers shall be calculated using actual load and application areas.
6. A summary of the daily pre-application inspection reports for the month.
7. Calculation of the flow-weighted average FDS concentration to date.
8. Monthly volume of residual solids generated and disposed of off-site. Include location and method of on-site storage.
9. A comparison of monitoring data to the flow limitations, effluent limitations; mass loading limitations (for each LAA field), and discharge specifications, and an explanation of any violation of those requirements.
10. If requested by staff, copies of laboratory analytical report(s).
11. Copies of current calibration logs for all field test instruments.

B. Quarterly Monitoring Report

The Discharger shall establish a quarterly sampling schedule for groundwater monitoring such that samples are obtained approximately every three months. Quarterly monitoring reports shall be submitted to the Water Quality Control Board by the **1st day of the second month after the quarter** (i.e. the January-March quarter is due by May 1st) each year. The Quarterly Report submittal schedule is shown in the table below.

Quarter	Monitoring Period	Quarterly Report Due Date
First	January - March	1 May
Second	April - June	1 August
Third	July – September	1 November
Fourth	October - December	1 February

The Quarterly Report shall include the following:

1. Results of groundwater monitoring.
2. A narrative description of all preparatory, monitoring, sampling, and analytical testing activities for the groundwater monitoring. The narrative shall be sufficiently detailed to verify compliance with the WDRs, this MRP, and the Standard Provisions and Reporting Requirements. The narrative shall be supported by field logs for each well documenting depth to groundwater; method of purging and parameters measured before, during, and after purging. Low or no-purge sampling methods are acceptable if described in an approved Sampling and Analysis Plan.
3. Calculation of groundwater elevations, an assessment of groundwater flow direction and gradient on the date of measurement, comparison with previous flow direction and gradient data, and discussion of seasonal trends if any;
4. Summary data tables of historical and current water table elevations and analytical results;
5. A scaled map showing relevant structures and features of the facility, the locations of monitoring wells and any other sampling stations, and groundwater elevation contours referenced to mean sea level datum; and
6. Copies of laboratory analytical report(s) for groundwater monitoring.

C. Annual Monitoring Report

An Annual Report shall be submitted to the Central Valley Water Board by **1 February** each year and shall include the following:

1. Total annual flow measurement from wastewater and each supplemental irrigation source to the LAAs for the calendar year. Comparison of wastewater flow to the annual maximum flow limit.
2. Flow-weighted annual average FDS concentration from Pond 2 for the calendar year with supporting data and calculations and comparison to the effluent limit.
3. Total hydraulic loading rate and total nitrogen loading rate applied to each LAA field for

the calendar year with supporting data and calculations and comparison to crop evapotranspiration rate and nitrogen demand.

4. A nitrogen mass balance (from all sources) for the calendar year with supporting data and calculations. Include description of ground cover crops if planted and dates of planting and harvest for each crop. If the mass balance indicates that nitrogen has been applied in excess of the agronomic rate, include a discussion of any corrective action performed during the year and a plan and schedule for additional corrective actions if needed to ensure future compliance with the land application area specifications of the WDRs.
5. Concentration vs. time graphs for each monitored constituent using all historic groundwater monitoring data. Each graph shall show the background groundwater concentration range, the trigger concentration specified above (where applicable), and the Groundwater Limitation as horizontal lines at the applicable concentration.
6. An evaluation of the groundwater quality beneath the site and determination of whether any trigger concentrations were exceeded in any compliance well at any time during the calendar year. This shall be determined by comparing the annual average concentration for each well during the calendar year to the corresponding trigger concentration specified above. If any groundwater trigger concentrations were exceeded, include acknowledgment that the technical report described in the Groundwater Trigger Concentrations section of this MRP will be submitted in accordance with the specified schedule.
7. **Effective 1 February 2017**, an evaluation of the groundwater quality beneath the site and determination of Compliance with the Groundwater Limitations of the WDRs based on statistical analysis for each constituent monitored for each compliance well in accordance with the approved *Groundwater Limitations Compliance Assessment Plan*. Include all calculations and data input/analysis tables derived from use of statistical software as applicable.
8. A discussion of compliance and the corrective actions taken, as well as any planned or proposed actions needed to bring the discharge into full compliance with the waste discharge requirements.
9. A discussion of the following:
 - a. Waste constituent reduction efforts implemented in accordance with any required workplan;
 - b. Other treatment or control measures implemented during the calendar year either voluntarily or pursuant to the WDRs, this MRP, or any other Order; and
 - c. Based on monitoring data, an evaluation of the effectiveness of the treatment or control measures implemented to date.
10. A discussion of any data gaps and potential deficiencies/redundancies in the monitoring system or reporting program.

A letter transmitting the self-monitoring reports shall accompany each report. The letter shall include a discussion of requirement violations found during the reporting period, and actions taken or planned for correcting noted violations, such as operation or facility modifications. If the Discharger has previously submitted a report describing corrective actions and/or a time schedule for implementing the corrective actions, reference to the previous correspondence will be satisfactory. The transmittal letter shall contain the penalty of perjury statement by the Discharger, or the Discharger's authorized agent, as described in the Standard Provisions General Reporting Requirements Section B.3.

The Discharger shall implement the above monitoring program as of the date of this Order.

Ordered by: _____ Original signed by _____
PAMELA C. CREEDON, Executive Officer
28 March 2014

(Date)

INFORMATION SHEET

WASTE DISCHARGE REQUIREMENTS ORDER R5-2014-0059
HUGHSON NUT, INC.
VERDUGA ROAD FACILITY
STANISLAUS COUNTY

Background

Hughson Nut, Inc. (“Discharger”) owns and operates the Hughson Nut Verduga Road Facility, which is located approximately three miles east from the City of Hughson and one mile south of the Tuolumne River. The facility began operation in 1985 and processes harvested almonds that have been hulled and shelled. The facility neighbors an almond hulling and shelling company, which is owned and operated independently.

The facility sorts raw almonds by variety, size, and quality. Sorted almonds are transferred for either dry processing or steam blanching to remove the skin. The blanching process was added in 1988 and generates wastewater from prewashing, blanching and rinsing of almonds, boiler blowdown, and blanching equipment cleaning/sanitization. The majority of wastewater is generated during the actual steam blanching process. The facility operates up to 20 to 22 hours a day, 6 days a week during the peak almond processing season, which is typically September through April. During the peak season the facility employs up to 150 workers.

The Discharger has not metered wastewater flows. The 2007 Report of Waste Discharge estimates the monthly average wastewater flow to be 15,000 to 16,000 gallons per day (gpd) during the peak operating season based on the blancher size. In September 2013 the Discharger provided information to amend the 2007 RWD. The Discharger states that almond production has increased from approximately 45,000 to 90,000 pounds per day and the monthly average wastewater flow is now expected to be approximately 41,000 gpd. Wastewater flows are based on metered flows from the supply groundwater well and estimated water losses during the blanching process and from domestic use. The estimation of wastewater flows is not accurate and, therefore, this Order requires the Discharger to install a flow meter to reliably measure wastewater flows. The Discharger is requesting a monthly average flow limit of 64,000 gpd to accommodate future expansion.

All process wastewater is run through a parabolic screen prior to being discharged to Pond 1, which is a concrete lined aeration pond. Effluent from Pond 1 gravity flows to Pond 2, which is an aerated unlined earthen pond. Wastewater from Pond 2 is used for irrigation of about 55 acres of on-site almond orchards.

Site-Specific Conditions

The site is relatively level at an elevation of approximately 140 feet above mean sea level (MSL). Surface water drainage is generally south to north toward the Tuolumne River, which is approximately 1 mile north of the facility. Surrounding land uses are primarily agricultural with some residences. The Discharger states that local agriculture crops primarily consist of almond orchards that use groundwater and Turlock Irrigation District water for irrigation.

Groundwater Considerations

In January 2011 the Discharger installed three groundwater monitoring wells MW-1, MW-2, and MW-3. Groundwater monitoring data indicate that depth to groundwater is generally 70 to 85-feet below ground surface and flows toward the east with a gradient that ranges from 0.0009 to 0.0019. Based on the groundwater gradient, MW-1 is downgradient of Pond 2, Pond 3, and the LAA. MW-2 is spatially upgradient of Pond 2 but is likely influenced by percolation from Pond 2. MW-3 was intended to monitor background groundwater quality but the proposed land application area was changed and now encompasses MW-3. Because the facility does not have an adequate groundwater monitoring well network, this Order requires the Discharger to submit a *Groundwater Monitoring Well Installation Workplan* to monitor background groundwater quality.

Groundwater quality was sampled for key constituents a few days after installing the monitoring wells. Since then, pH and total dissolved solids (TDS) have been sampled on a quarterly basis. Sampling results are summarized in the following table:

Constituent	Units	MW-1	MW-2	MW-3	Potential WQO
pH ¹	S.U.	6.4 (5.9 - 6.9)	7.0 (6.7 - 7.5)	7.2 (6.6 - 7.7)	6.5 - 8.5 ³
TDS ¹	mg/L	403 (350-440)	638 (580-700)	459 (420-500)	450 ⁵ - 1,500 ³
Nitrate (as N) ²	mg/L	15.8	28.4	15.0	10 ⁴
Chloride ²	mg/L	15	25	19	106 ⁵ - 600 ³
Sodium ²	mg/L	37	50	132	69 ⁵
Boron ²	mg/L	0.05	0.09	< 0.1	0.7 ⁵
Iron ²	mg/L	< 0.05	< 0.05	< 0.05	0.3 ³
Manganese ²	mg/L	0.0132	0.0057	0.02	0.05 ³
Potassium ²	mg/L	3	4	4	--

¹ Average and range of data collected quarterly from January 2011 through May 2013.

² Single sample collected in January 2011 after the monitoring wells were installed.

³ Secondary Maximum Contaminant Level

⁴ Primary Maximum Contaminant Level

⁵ Lowest agricultural water quality goal

Without background groundwater monitoring data it is not possible to evaluate whether degradation has occurred or the extent of degradation. The following preliminary assessment of groundwater degradation is based on available monitoring data but is not conclusive:

- a. MW-2 data indicate that Pond 2 may be causing groundwater degradation with respect to TDS but not exceedance of the water quality objective. MW-2 data also indicates that the discharge may have caused or contributed to localized nitrate pollution.
- b. Monitoring well MW-1 data indicate that infiltration from the storm water pond (Pond 3) may dilute groundwater TDS concentrations as groundwater travels from

MW-2 to MW-1. MW-1 data also show the pH concentration is, at times, below the lower MCL of 6.5. It is not clear whether the low pH concentration is naturally occurring or is caused by Pond 2, Pond 3, or acidic leachate associated with temporary storage of almond hulls by the neighboring hulling company.

Basin Plan, Beneficial Uses, and Regulatory Considerations

Local drainage is to Tuolumne River. The beneficial uses of Tuolumne River, as stated in the Basin Plan, are municipal and domestic supply; agricultural supply; water contact recreation; non-contact water recreation; warm freshwater habitat; cold freshwater habitat; wildlife habitat; migration of aquatic organisms; and spawning, reproduction, and/or early development.

The beneficial uses of underlying groundwater as set forth in the Basin Plan are municipal and domestic supply, agricultural supply, industrial service supply and industrial process supply.

Antidegradation Analysis

State Water Resources Control Board Resolution 68-16 ("Policy with Respect to Maintaining High Quality Waters of the State") (hereafter Resolution 68-16) prohibits degradation of groundwater unless it has been shown that:

- a. The degradation is consistent with the maximum benefit to the people of the state.
- b. The degradation will not unreasonably affect present and anticipated future beneficial uses.
- c. The degradation does not result in water quality less than that prescribed in state and regional policies, including violation of one or more water quality objectives, and
- d. The discharger employs best practicable treatment or control (BPTC) to minimize degradation.

The Discharger has been monitoring groundwater quality at the site since 2011. The California Department of Water Resources' (DWR) Water Quality Library indicates one well, station name 04S10E11J001M, that is close to the facility and has been monitored for ground water quality. The well was monitored once in December 1949 using an unknown analytical method and results were as follows: 0.16 mg/L boron; 21 mg/L chloride; 160 μ mhos/cm electrical conductivity; 0.7 mg/L magnesium; and 46 mg/L sodium. The DWR states that unknown analytical methods may not compare with modern data. Based on the data available, it is not possible to determine pre-1968 groundwater quality. Therefore, determination of compliance with Resolution 68-16 for this facility must be based on existing background groundwater quality. As stated previously, background quality cannot yet be determined due to an inadequate groundwater monitoring well network.

Constituents of concern that have the potential to degrade groundwater include salts (primarily TDS), nutrients, and pH. Degradation of groundwater by some of the typical waste

constituents associated with discharge from food processing facilities, after effective source control, treatment, and control measures are implemented, is consistent with the maximum benefit to the people of the state. The economic prosperity of the community by direct employment of fulltime and seasonal personnel and associated industry is of maximum benefit to the people of the State, and provides sufficient justification for allowing limited groundwater degradation that may occur pursuant to this Order.

The following treatment and control measures are implemented at the facility:

- Use of high quality water for source water and supplemental irrigation, which reduces percolate salinity.
- Disposing of boiler precipitate at a landfill to reduce constituent concentrations in the wastewater.
- Screening the wastewater prior to discharge to reduce BOD and nitrogen.
- Approximately 55 acres of LAAs are available. Crops are grown on the LAAs and will take up the nutrients found in the wastewater if wastewater application rates are carefully controlled.

To assure protection of the beneficial uses of groundwater, this Order establishes flow limitations, effluent and mass loading limitations, groundwater limitations, discharge specifications, land application area requirements, solids disposal specifications, and groundwater monitoring requirements.

Flow Limitations

Influent flows to the wastewater treatment system shall not exceed the following limits:

<u>Flow Measurement</u>	<u>Flow Limit</u>
Maximum Average Daily Flow ²	64,000 MGD
Total Annual Flow ¹	23.5 MG

¹ As determined by the total flow during the calendar month divided by the number of days in that month.

² As determined by the total flow for the calendar year.

Effluent and Mass Loading Limitations

The blend of treated wastewater, storm water, and supplemental irrigation water applied to the LAAs shall not exceed the following effluent and mass loading limits:

Constituent	Units	Cycle Average¹	Annual Maximum
BOD Mass Loading	lb/ac/day	100	--
Average FDS Concentration	mg/L	--	500 ²

Constituent	Units	Cycle Average ¹	Annual Maximum
Total Nitrogen Mass Loading	lb/ac/year	--	Crop Demand

¹ This limit applies as irrigation cycle average. For the purpose of this Order, "irrigation cycle" is defined as the time period between the start of an irrigation event and the start of the next irrigation event on the same LAA field identified in Attachment B.

² Flow-weighted average based on total flow and concentration discharged.

Groundwater Limitations

Release of waste constituents from any portion of the facility shall not cause groundwater to contain any of the specified constituents in a concentration statistically greater than the maximum allowable concentration tabulated below. **The wells to which these requirements apply are specified in the Monitoring and Report Program.**

Parameter	Units	Water Quality Objective	Allowable Concentration	Date Effective ¹
Nitrate nitrogen	mg/L	10	Background groundwater quality or the Water Quality Objective, whichever is greater	Immediately

¹ Applies only to the specific compliance monitoring wells listed in the Monitoring and Reporting Program.

Provisions

- a. By **1 July 2014**, the Discharger shall submit a *Groundwater Monitoring Well Installation Workplan* that proposes at least two additional monitoring wells to ensure adequate monitoring upgradient and downgradient of all wastewater ponds as well as the land application area.
- b. By **1 September 2014**, the Discharger shall submit a *Flow Meter Installation Report*. The report shall describe the installation of a flow meter to monitor effluent flows at the locations shown schematically on Attachment C.
- c. By **1 November 2014**, the Discharger shall submit a *Groundwater Monitoring Well Installation Report* for any new groundwater monitoring wells.
- d. By **1 February 2017**, the Discharger shall submit a *Groundwater Quality Study* that determines background groundwater quality, evaluates groundwater degradation, and describes the statistical methods used to determine compliance.

If groundwater monitoring results show that the discharge of waste is causing groundwater to contain any waste constituents in concentrations statistically greater than the Groundwater Limitations of this Order, within 120 days of the request of the Executive Officer, the Discharger shall submit a *BPTC Evaluation Workplan*.

Monitoring Requirements

The Monitoring and Reporting Program is designed to verify compliance with the flow and effluent limitations and operational requirements of the WDRs. The Order requires monitoring

of the ponds, wastewater flows to the land application areas, wastewater quality, land application area, groundwater, and residual solids. Groundwater limitations are necessary to protect the municipal and domestic use of groundwater. If results of the monitoring reveal a previously undetected threat to water quality or indicate a change in waste character such that the threat to water quality is significantly increased, the Central Valley Water Board may reopen this Order to reconsider groundwater limitations and other requirements to comply with Resolution 68-16.

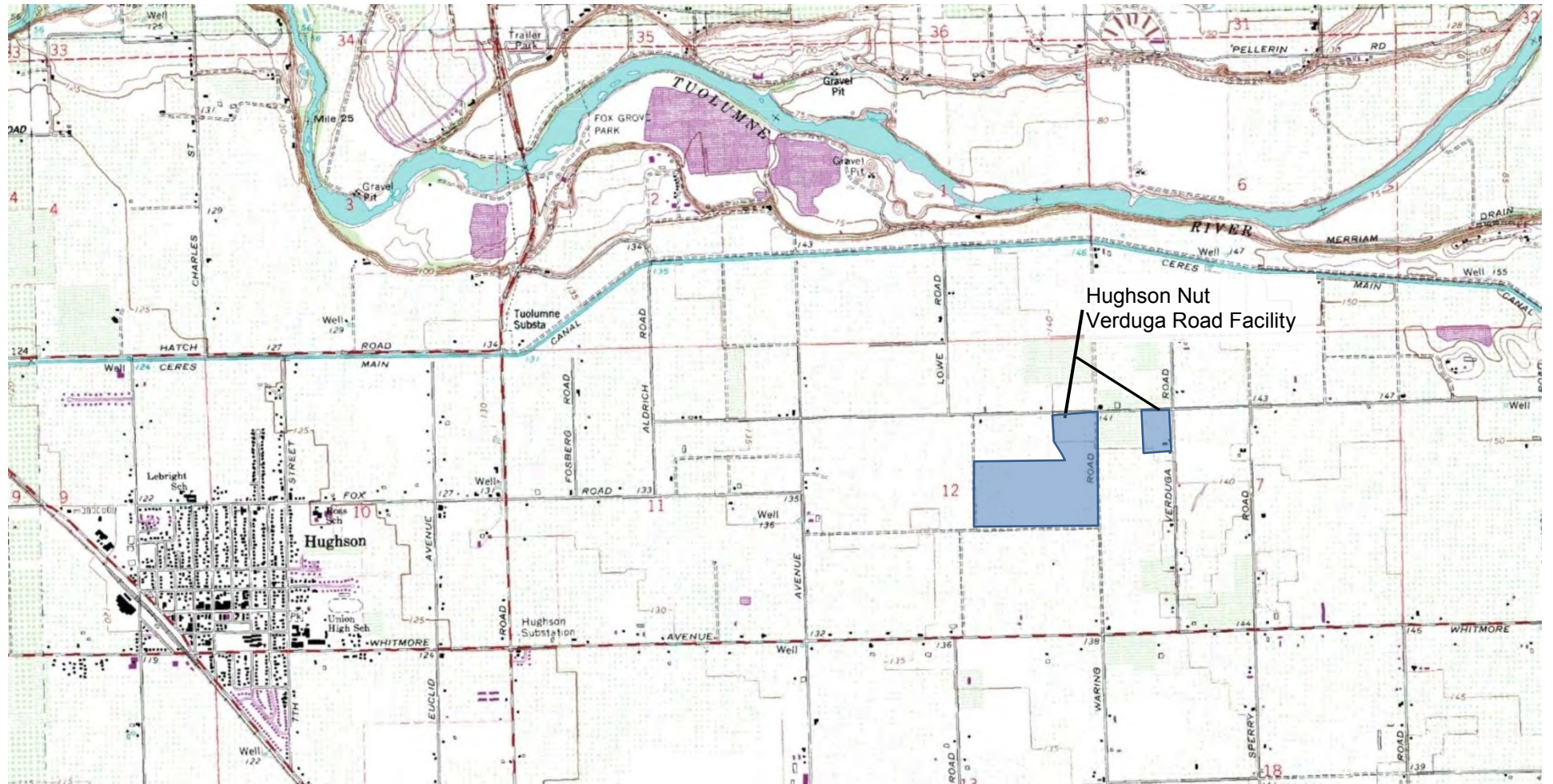

DRAWING REFERENCE:

RWD
August 2007

FACILITY LOCATION
HUGHSON NUT INC.
VERDUGA ROAD FACILITY
STANISLAUS COUNTY

Approximate Scale:
1 inch = 2,600 feet

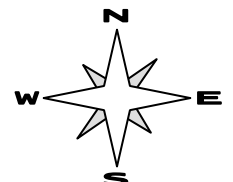

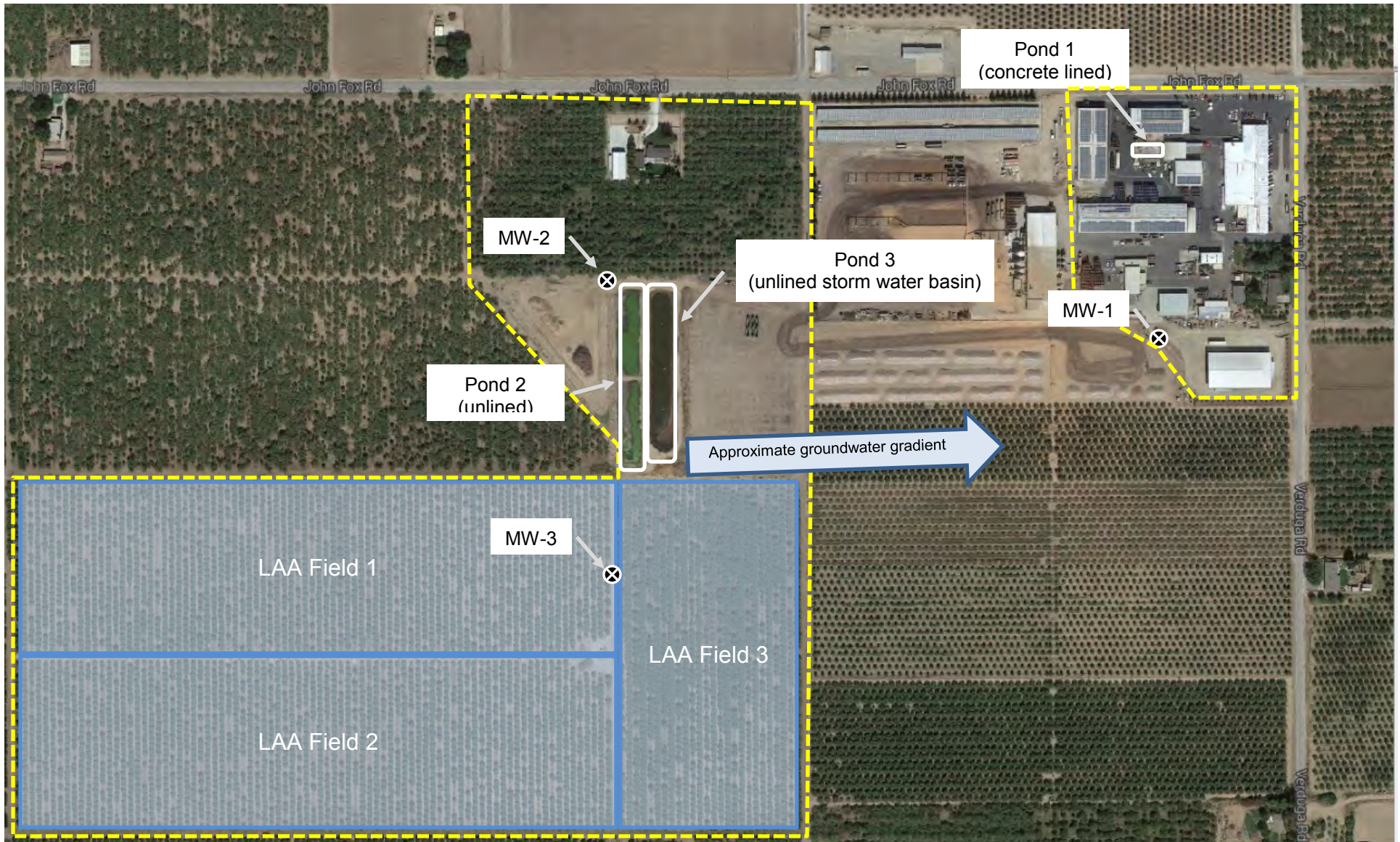

DRAWING REFERENCE:
Monitoring Well Installation
Workplan
October 2010

SITE PLAN
HUGHSON NUT INC.
VERDUGA ROAD FACILITY
STANISLAUS COUNTY

Approximate Scale:
1 inch = 350 feet

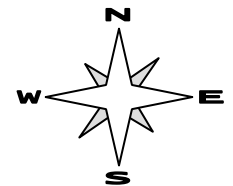

PLANT WELL
(POTABLE WATER)

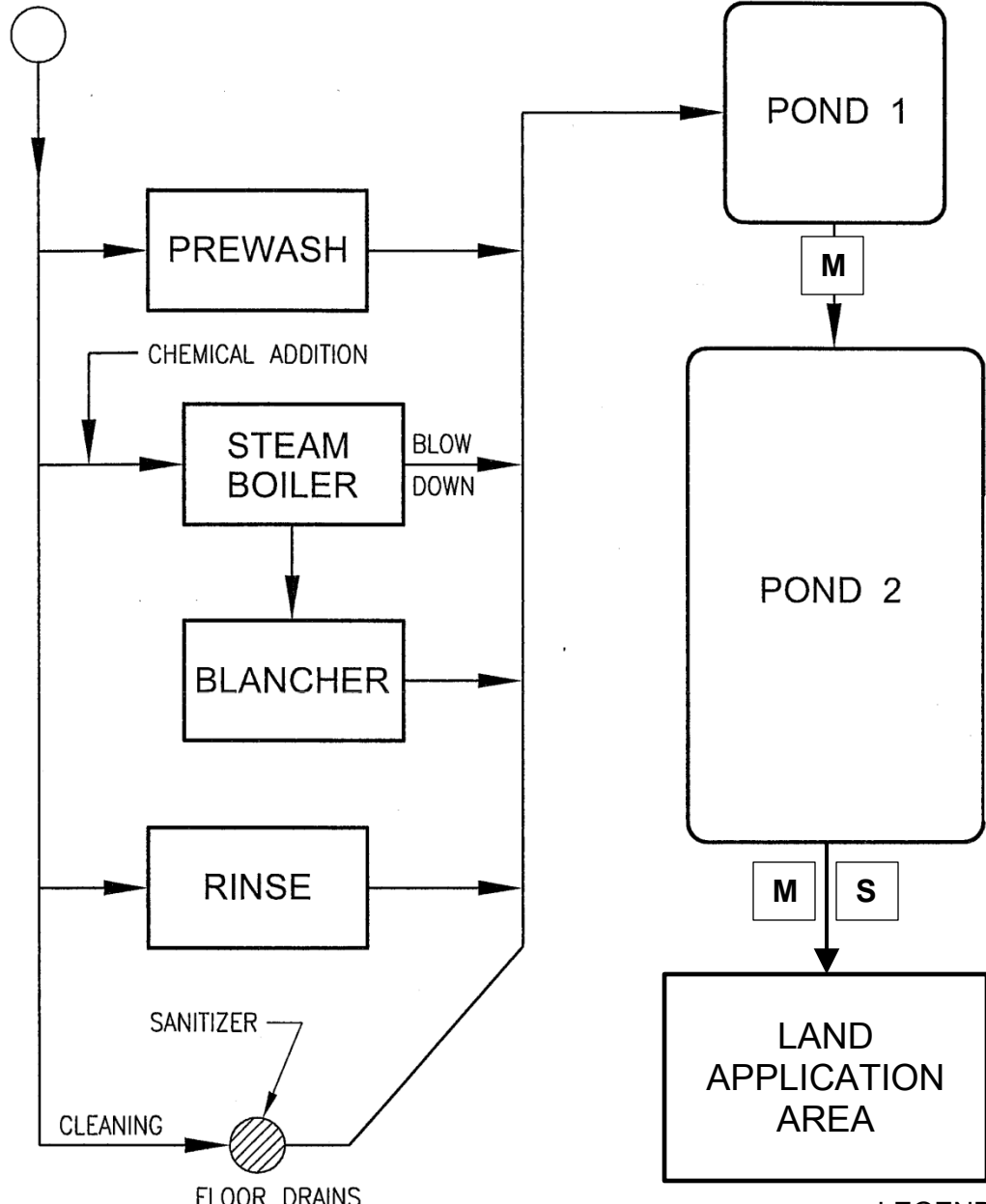

LEGEND

— Water flow

S Required effluent limit sampling and compliance point

M Required flow limit compliance point. Flow meter to be installed pursuant to Provision H.1.a

DRAWING REFERENCE:

RWD
August 2007

PROCESS FLOW SCHEMATIC

HUGHSON NUT INC.
VERDUGA ROAD FACILITY
STANISLAUS COUNTY

ATTACHMENT D

**REQUIREMENTS FOR
MONITORING WELL INSTALLATION WORKPLANS AND
MONITORING WELL INSTALLATION REPORTS**

Prior to installation of groundwater monitoring wells, the Discharger shall submit a workplan containing, at a minimum, the information listed in Section 1 below. Wells may be installed after staff approves the workplan. Upon installation of the monitoring wells, the Discharger shall submit a well installation report that includes the information contained in Section 2 below. All workplans and reports must be prepared under the direction of, and signed by, a registered geologist or civil engineer licensed by the State of California.

SECTION 1 - Monitoring Well Installation Workplan and Groundwater Sampling and Analysis Plan

The monitoring well installation workplan shall contain the following minimum information:

A. General Information:

- Purpose of the well installation project
- Brief description of local geologic and hydrogeologic conditions
- Proposed monitoring well locations and rationale for well locations
- Topographic map showing facility location, roads, and surface water bodies
- Large scaled site map showing all existing on-site wells, proposed wells, surface drainage courses, surface water bodies, buildings, waste handling facilities, utilities, and major physical and man-made features

B. Drilling Details:

- On-site supervision of drilling and well installation activities
- Description of drilling equipment and techniques
- Equipment decontamination procedures
- Soil sampling intervals (if appropriate) and logging methods

C. Monitoring Well Design (in narrative and/or graphic form):

Diagram of proposed well construction details:

- Borehole diameter
- Casing and screen material, diameter, and centralizer spacing (if needed)
- Type of well caps (bottom cap either screw on or secured with stainless steel screws)
- Anticipated depth of well, length of well casing, and length and position of perforated interval
- Thickness, position and composition of surface seal, sanitary seal, and sand pack
- Anticipated screen slot size and filter pack

D. Well Development (not to be performed until at least 48 hours after sanitary seal placement):

- Method of development to be used (i.e., surge, bail, pump, etc.)
- Parameters to be monitored during development and record keeping technique
- Method of determining when development is complete
- Disposal of development water

- E. Well Survey (precision of vertical survey data shall be at least 0.01 foot):
Identify the Licensed Land Surveyor or Civil Engineer that will perform the survey
Datum for survey measurements
List well features to be surveyed (i.e. top of casing, horizontal and vertical coordinates, etc.)
- F. Schedule for Completion of Work
- G. Appendix: Groundwater Sampling and Analysis Plan (SAP)
The Groundwater SAP shall be included as an appendix to the workplan, and shall be utilized as a guidance document that is referred to by individuals responsible for conducting groundwater monitoring and sampling activities.

Provide a detailed written description of standard operating procedures for the following:

- Equipment to be used during sampling
- Equipment decontamination procedures
- Water level measurement procedures
- Well purging (include a discussion of procedures to follow if three casing volumes cannot be purged)
- Monitoring and record keeping during water level measurement and well purging (include copies of record keeping logs to be used)
- Purge water disposal
- Analytical methods and required reporting limits
- Sample containers and preservatives
- Sampling
 - General sampling techniques
 - Record keeping during sampling (include copies of record keeping logs to be used)
 - QA/QC samples
- Chain of Custody
- Sample handling and transport

SECTION 2 - Monitoring Well Installation Report

The monitoring well installation report must provide the information listed below. In addition, the report must also clearly identify, describe, and justify any deviations from the approved workplan.

- A. General Information:
Purpose of the well installation project
Brief description of local geologic and hydrogeologic conditions encountered during installation of the wells
Number of monitoring wells installed and copies of County Well Construction Permits
Topographic map showing facility location, roads, surface water bodies

Scaled site map showing all previously existing wells, newly installed wells, surface water bodies, buildings, waste handling facilities, utilities, and other major physical and man-made features.

B. Drilling Details (in narrative and/or graphic form):

On-site supervision of drilling and well installation activities

Drilling contractor and driller's name

Description of drilling equipment and techniques

Equipment decontamination procedures

Soil sampling intervals and logging methods

Well boring log:

- Well boring number and date drilled
- Borehole diameter and total depth
- Total depth of open hole (same as total depth drilled if no caving or back-grouting occurs)
- Depth to first encountered groundwater and stabilized groundwater depth
- Detailed description of soils encountered, using the Unified Soil Classification System

C. Well Construction Details (in narrative and/or graphic form):

Well construction diagram, including:

- Monitoring well number and date constructed
- Casing and screen material, diameter, and centralizer spacing (if needed)
- Length of well casing, and length and position of perforated interval
- Thickness, position and composition of surface seal, sanitary seal, and sand pack
- Type of well caps (bottom cap either screw on or secured with stainless steel screws)

E. Well Development:

Date(s) and method of development

How well development completion was determined

Volume of water purged from well and method of development water disposal

Field notes from well development should be included in report

F. Well Survey (survey the top rim of the well casing with the cap removed):

Identify the coordinate system and datum for survey measurements

Describe the measuring points (i.e. ground surface, top of casing, etc.)

Present the well survey report data in a table

Include the Registered Engineer or Licensed Surveyor's report and field notes in appendix

Central Valley Regional Water Quality Control Board

14 April 2014

Raquel Andrade, Manager
Hughson Nut, Inc.
11173 W. Mercedes Avenue
Livingston, CA, 95334

CERTIFIED MAIL
7013 1090 0001 3130 4124

**NOTICE OF ADOPTION
OF
ORDER R5-2014-0059
WASTE DISCHARGE REQUIREMENTS
FOR
HUGHSON NUT, INC.
VERDUGA ROAD ALMOND PROCESSING FACILITY
STANISLAUS COUNTY**

Waste Discharge Requirements (WDRs) Order R5-2014-0059 for the Hughson Nut, Inc. Verduga Road Almond Processing Facility was adopted by the Central Valley Regional Water Quality Control Board on 28 March 2014.

Although the WDRs allow wastewater discharge to land, the discharge is a privilege not a right and may be revoked at any time. A copy of the Order must be maintained at the facility and must be accessible to anyone operating the wastewater system. Please note that the Provisions section of the WDRs requires submittal of certain technical reports by the dates provided in the Order. The required submittals include the items listed in the following table.

Required Reports	Due Date
Groundwater Monitoring Well Installation Workplan	1 July 2014
Flow Meter Installation Report	1 September 2014
Groundwater Monitoring Well Installation Report	1 November 2014
Groundwater Quality Study	1 February 2017

In addition to technical reports required by the WDRs, the WDRs include a Monitoring and Reporting Program (MRP), which specifies monitoring and reporting requirements for you to implement. Please review the MRP closely so that you may establish appropriate sampling schedules and reporting protocols. The required monitoring report submittal dates are in the table below.

Required Monitoring Report	Due Date
<i>Monthly Monitoring Reports</i>	1st day of second month following the sampling (the February Report is due by 1 April)
<i>Quarterly Monitoring Reports</i>	1st day of the second month after the quarter (the January-March Quarterly Report is due by May 1st)
<i>Annual Monitoring Reports</i>	1 February of each year

Please be advised that the monitoring reports must be submitted on time and complete. Monitoring reports must include all of the items described in the Reporting Section of the MRP. **The first monitoring report is due on 1 June 2014 and is to cover the month of April 2014 monitoring.**

To conserve paper and reduce mailing costs, a paper copy of the Order has been sent only to the Discharger. Interested parties are advised that the full text of this Order is available at: http://www.waterboards.ca.gov/centralvalley/board_decisions/adopted_orders/. Anyone without access to the Internet who needs a paper copy of the Order can obtain one by contacting Central Valley Water Board staff.

Now that the permit has been adopted, the Board's Compliance and Enforcement section will take over management of your case. Guy Childs is your new point of contact for any questions about the Order. In addition, all monitoring and technical reports should be submitted to him. The enclosed transmittal sheet shall be included with each monitoring report. If you find it necessary to make a change to your permitted operations, Guy will direct you to the appropriate Permitting staff. You may contact Guy at (916) 464-4648 or at gchilds@waterboards.ca.gov.

ANNE OLSON, P.E.
Senior Water Resource Control Engineer
Waste Discharge to Land Permitting Section

Enclosures : Order No. R5-2014-0059
Standard Provisions and Reporting Requirements for Waste Discharge Requirements,
1 March 1991
Monthly and Annual Report Transmittal Sheet

cc w/o enc.: Patrick Pulupa, Office of Chief Counsel, State Water Board, Sacramento
WDR Program Manager, State Water Resources Control Board, Sacramento
Bella Bedal, Stanislaus County Environmental Health Department, Modesto
Alfonso Manrique, AM Consulting Engineers, Fresno