

**CALIFORNIA REGIONAL WATER QUALITY CONTROL BOARD
CENTRAL VALLEY REGION**

11020 Sun Center Drive, #200 Rancho Cordova, California 95670-6114
Phone (916) 464-3291 O Fax (916) 464-4645
[Central Valley Home Page](http://www.waterboards.ca.gov/centralvalley) (http://www.waterboards.ca.gov/centralvalley)

**NATIONAL POLLUTANT DISCHARGE ELIMINATION SYSTEM (NPDES) CA0081558
ORDER R5-2026-XXXX**

**TENTATIVE WASTE DISCHARGE REQUIREMENTS
FOR THE CITY OF MANTECA, WASTEWATER QUALITY CONTROL FACILITY
SAN JOAQUIN COUNTY**

The following Discharger is subject to waste discharge requirements (WDRs) set forth in this Order:

Table 1. Discharger Information

Discharger:	City of Manteca
Name of Facility:	Wastewater Control Facility
Facility Street Address:	2450 West Yosemite Avenue
Facility City, State, Zip:	Manteca, CA 95337
Facility County:	San Joaquin County

Table 2. Discharge Location

Discharge Point	Effluent Description	Discharge Point Latitude (North)	Discharge Point Longitude (West)	Receiving Water
001	Tertiary Treated Wastewater	37° 46' 45"	121° 18' 00"	San Joaquin River

Table 3. Administrative Information

This Order was Adopted on:	XX June 2026
This Order shall become effective on:	1 August 2026
This Order shall expire on:	31 July 2031
The Discharger shall file a Report of Waste Discharge (ROWD) as an application for reissuance of WDRs in accordance with title 23, California Code of Regulations (CCR), and an application for reissuance of a NPDES permit no later than:	31 July 2030
The United States Environmental Protection Agency (U.S. EPA) and the California Regional Water Quality Control Board, Central Valley Region have classified this discharge as follows:	Major

I, Patrick Pulupa, Executive Officer, do hereby certify that this Order with all attachments is a full, true, and correct copy of the Order adopted by the California Regional Water Quality Control Board, Central Valley Region, on **XX June 2026**.

PATRICK PULUPA, Executive Officer

**WASTE DISCHARGE REQUIREMENTS
TABLE OF CONTENTS**

I. Facility Information 3
II. Findings 3
III. Discharge Prohibitions 4
IV. Effluent Limitations and Discharge Specifications 5
 A. Effluent Limitations – Discharge Point 001 5
 1. Final Effluent Limitations – Discharge Point 001 5
 2. Interim Effluent Limitations 7
 B. Land Discharge Specifications 7
 C. Recycling Specifications 11
V. Receiving Water Limitations 11
 A. Surface Water Limitations - None 11
 B. Groundwater Limitations 11
VI. Provisions 12
 A. Standard Provisions 12
 B. Monitoring and Reporting Program (MRP) Requirements 16
 C. Special Provisions 17
 1. Reopener Provisions 17
 2. Special Studies, Technical Reports and Additional Monitoring Requirements 19
 3. Best Management Practices and Pollution Prevention 19
 4. Construction, Operation and Maintenance Specifications 20
 5. Special Provisions for Publicly-Owned Treatment Works (POTWs) 22
 6. Other Special Provisions 24
 7. Compliance Schedules 24
VII. Compliance Determination 25

TABLES

Table 1. Discharger Information 1
Table 2. Discharge Location 1
Table 3. Administrative Information 1
Table 4. Effluent Limitations 5
Table 5. Land Discharge Specifications 10

ATTACHMENTS

Attachment A – Definitions A-1
Attachment B – Map B-1
Attachment C – Flow Schematic C-1
Attachment D – Standard Provisions D-1
Attachment E – Monitoring and Reporting Program E-1
Attachment F – Fact Sheet F-1
Attachment G – Summary Of Reasonable Potential Analysis G-1
Attachment H – Calculation of WQBELS H-1

I. FACILITY INFORMATION

Information describing the City of Manteca (Discharger), Wastewater Quality Control Facility (Facility) is summarized in Table 1 and in sections I and II of the Fact Sheet (Attachment F). Section I of the Fact Sheet also includes information regarding the Facility's permit application.

II. FINDINGS

The California Regional Water Quality Control Board, Central Valley Region (hereinafter Central Valley Water Board), finds:

- A. Legal Authorities.** This Order serves as waste discharge requirements (WDRs) pursuant to article 4, chapter 4, division 7 of the California Water Code (commencing with section 13260). This Order is also issued pursuant to section 402 of the federal Clean Water Act (CWA) and implementing regulations adopted by the U.S. EPA and chapter 5.5, division 7 of the Water Code (commencing with section 13370). It shall serve as a National Pollutant Discharge Elimination System (NPDES) permit authorizing the Discharger to discharge into waters of the United States at the discharge location described in Table 2 subject to the WDRs in this Order.
- B. California Environmental Quality Act (CEQA).** Under Water Code section 13389, this action to adopt an NPDES permit is exempt from the provisions of Chapter 3 of CEQA, (commencing with section 21100) of Division 13 of Public Resources Code. Additionally, the adoption of land discharge requirements for the Facility constitutes permitting of an existing facility that is categorically exempt from the provisions of CEQA pursuant to CCR, title 14, section 15301.
- C. Background and Rationale for Requirements.** The Central Valley Water Board developed the requirements in this Order based on information submitted as part of the application, through monitoring and reporting programs, and other available information. The Fact Sheet (Attachment F), which contains background information and rationale for the requirements in this Order, is hereby incorporated into and constitutes Findings for this Order. Attachments A through E and G through H are also incorporated into this Order.
- D. Provisions and Requirements Implementing State Law.** The provisions/requirements in subsections **IV.B, IV.C, V.B, VI.C.4, and VI.C.6.a** are included to implement state law only. These provisions/requirements are not required or authorized under the federal CWA; consequently, violations of these provisions/requirements are not subject to the enforcement remedies that are available for NPDES violations.
- E. Monitoring and Reporting.** 40 C.F.R. section 122.48 requires that all NPDES permits specify requirements for recording and reporting monitoring results. Water Code sections 13267 and 13383 authorize the Central Valley Water Board to establish monitoring, inspection, entry, reporting, and recordkeeping requirements. This Order and the Monitoring and Reporting Program, provided in Attachment E, establish monitoring and reporting requirements to implement federal and State

requirements. The burden, including costs, of these monitoring and reporting requirements bears a reasonable relationship to the need for these reports and the benefits to be obtained therefrom. The Discharger, as owner and operator of the Facility, is responsible for these requirements, which are necessary to determine compliance with this Order. The need for these requirements is further discussed in the Fact Sheet, Attachment F.

- F. Notification of Interested Persons.** The Central Valley Water Board has notified the Discharger and interested agencies and persons of its intent to prescribe WDRs for the discharge and has provided them with an opportunity to submit their written comments and recommendations. Details of the notification are provided in the Fact Sheet.
- G. Consideration of Public Comment.** The Central Valley Water Board, in a public meeting, heard and considered all comments pertaining to the discharge. Details of the Public Hearing are provided in the Fact Sheet.

THEREFORE, IT IS HEREBY ORDERED that Order R5-2021-0003 is rescinded upon the effective date of this Order except for enforcement purposes, and, in order to meet the provisions contained in division 7 of the Water Code (commencing with section 13000) and regulations adopted thereunder, and the provisions of the CWA and regulations and guidelines adopted thereunder, the Discharger shall comply with the requirements in this Order. This action in no way prevents the Central Valley Water Board from taking enforcement action for violations of the previous Order.

III. DISCHARGE PROHIBITIONS

- A.** Discharge of wastewater from the Facility, as the Facility is specifically described in the Fact Sheet in section II.B, in a manner different from that described in this Order is prohibited.
- B.** The by-pass or overflow of wastes to surface waters is prohibited, except as allowed by Federal Standard Provisions I.G. and I.H. (Attachment D).
- C.** Neither the discharge nor its treatment shall create a nuisance as defined in section 13050 of the Water Code.
- D.** Discharge of waste classified as 'hazardous', as defined in the CCR, title 22, section 66261.1 et seq., is prohibited.
- E. Average Dry Weather Flow:**
 - 1. Effective immediately and until compliance with Special Provisions section VI.C.6.c,** discharges exceeding an average dry weather flow of 9.87 million gallons per day (MGD) are prohibited.
 - 2. Effective upon compliance with Special Provisions section VI.C.6.c,** discharges exceeding an average dry weather flow of 12.87 MGD are prohibited.

F. Central Valley Salinity Alternatives for Long-Term Sustainability (CV-SALTS).
During Phase I of the Salt Control Program, the Discharger is prohibited from discharging salts at concentrations exceeding the salinity numeric value of 700 $\mu\text{mhos/cm}$ (as a monthly average) unless the Discharger is implementing the Phase I requirements of the Salt Control Program Alternative Permitting Approach (i.e., full participation in the Prioritization and Optimization Study). The Discharger is prohibited from discharging nitrate and other forms of nitrogen speciation (e.g., total inorganic nitrogen and total Kjeldahl nitrogen) unless the Discharger is implementing the requirements of the Nitrate Control Program Management Zone Approach.

IV. EFFLUENT LIMITATIONS AND DISCHARGE SPECIFICATIONS

A. Effluent Limitations – Discharge Point 001

1. Final Effluent Limitations – Discharge Point 001

The Discharger shall maintain compliance with the following effluent limitations at Discharge Point 001. Unless otherwise specified compliance shall be measured at Monitoring Location EFF-001, as described in the Monitoring and Reporting Program, Attachment E:

- a. The Discharger shall maintain compliance with the effluent limitations specified in Table 4:

Table 4. Effluent Limitations

Parameters	Units	Average Monthly	Average Weekly	Maximum Daily
Ammonia Nitrogen, Total (as N) (1 April through 30 November)	milligrams per liter (mg/L)	1.9	4.0	--
Ammonia Nitrogen, Total (as N) (1 April through 30 November)	pounds per day (lbs/day) (see table note 1)	160	330	
Ammonia Nitrogen, Total (as N) (1 April through 30 November)	lbs/day (see table note 2)	200	430	
Ammonia Nitrogen, Total (as N) (1 December through 31 March)	mg/L	2.4	6.9	--
Ammonia Nitrogen, Total (as N) (1 December through 31 March)	lbs/day (see table note 1)	200	570	--
Ammonia Nitrogen, Total (as N) (1 December through 31 March)	lbs/day (see table note 2)	260	740	--

Parameters	Units	Average Monthly	Average Weekly	Maximum Daily
Biochemical Oxygen Demand, 5-day @ 20°Celsius (BOD ₅)	mg/L	10	15	--
Dieldrin	Nanograms per liter (ng/L)	0.14	--	0.34
Nitrate Plus Nitrite (as N)	mg/L	10	20	--
Total Suspended Solids (TSS)	mg/L	10	15	--

Table 4 Notes:

1. Based on an average dry weather flow of 9.87 MGD.
2. Based on an average dry weather flow of 12.87 MGD.
 - b. **Chronic Whole Effluent Toxicity MDEL.** No water flea (*Ceriodaphnia dubia*) chronic aquatic toxicity test shall result in a “Fail” at the Instream Waste Concentration (IWC) for the sub-lethal endpoint measured in the test AND a percent effect for the survival endpoint greater than or equal to 50 percent.
 - c. **Chronic Whole Effluent Toxicity MMEL.** No more than one *Ceriodaphnia dubia* chronic aquatic toxicity test initiated in a toxicity calendar month shall result in a “Fail” at the IWC for any endpoint.
 - d. **Diazinon and Chlorpyrifos.** Effluent diazinon and chlorpyrifos concentrations shall not exceed the sum of one (1.0) as identified below:
 - i. Average Monthly Effluent Limitation (AMEL)

$SAMEL = CD\ M\text{-avg}/0.079 + CC\ M\text{-avg}/0.012 \leq 1.0$
CD M-AVG = average monthly diazinon effluent concentration in µg/L.
CC M-AVG = average monthly chlorpyrifos effluent concentration in µg/L
 - ii. Average Weekly Effluent Limitation (AWEL)

$SAWEL = CD\ W\text{-avg}/0.14 + CC\ W\text{-avg}/0.021 \leq 1.0$
CD W-AVG = average weekly diazinon effluent concentration in µg/L.
CC W-AVG = average weekly chlorpyrifos effluent concentration in µg/L.

- e. **Methylmercury. Effective 31 December 2030.** The effluent calendar year annual methylmercury load shall not exceed 0.38 grams, in accordance with the Delta Mercury Control Program.
- f. **Percent Removal.** The average monthly percent removal of BOD₅ and TSS shall not be less than 85 percent.
- g. **pH:**
 - i. 6.5 Standard Units (SU) as an instantaneous minimum.
 - ii. 8.5 SU as an instantaneous maximum.
- h. **Temperature.** The maximum temperature of the discharge shall not exceed the natural receiving water temperature by more than 20° Fahrenheit (°F).
- i. **Total Coliform Organisms.** Effluent total coliform organisms shall not exceed the following with compliance measured at Monitoring Location UVS-001 as described in the MRP, Attachment E:
 - i. 2.2 most probable number per 100 milliliters (MPN/100 mL), as a 7-day median;
 - ii. 23 MPN/100 mL, more than once in any 30-day period; and
 - iii. 240 MPN/100 mL, at any time.

2. Interim Effluent Limitations

The Discharger shall maintain compliance with the following interim effluent limitations at Discharge Point 001, with compliance measured at Monitoring Location EFF-001 as described in the Monitoring and Reporting Program, Attachment E:

- a. **Mercury, total. Effective immediately and until 30 December 2030,** for a calendar year, the total annual mass discharge of total mercury shall not exceed 90 grams/year. This interim effluent limitation shall apply in lieu of the final effluent limitation for methylmercury (Section IV.A.1.e).

B. Land Discharge Specifications

The Discharger shall maintain compliance with the following land application area specifications when applying recycled water to the City owned land application agricultural fields shown in Figure B-2 (Attachment B), monitored at Monitoring Location LND-001. Recycled water applied to Land Application Areas (LAAs) for this Facility contains undisinfected secondary municipal wastewater and food processing

wastewater from Eckert Cold Storage. Loading calculations shall be performed as specified below.

1. **Hydraulic Loading.** The volume of recycled water applied to the use areas shall not exceed agronomic rates based on the vegetation grown, pre-discharge soil moisture conditions, and weather conditions. Hydraulic loading of recycled water and supplemental irrigation water (if any) shall be at agronomic rates designed to:
 - a. Maximize crop nutrient uptake.
 - b. Maximize breakdown of organic waste constituents in the root zone; and
 - c. Minimize the percolation of waste constituents below the root zone.

The Central Valley Water Board recognizes that some leaching of salts is necessary to manage salt in the root zone of crops for production. Leaching shall be managed to minimize degradation of groundwater, maintain compliance with the groundwater limitations of this Order, and to prevent pollution.

2. **Total Nitrogen.** Crops shall be grown on the use areas, and cropping activities shall be managed to take up the nitrogen applied, including any fertilizers and manure. The total nitrogen mass loading to LAAs shall not exceed the agronomic rate for the crop grown. Compliance with this requirement shall be determined using published nitrogen uptake rates for the vegetation/crops grown and the following formula.

$$M = \sum_{i=1}^{12} \frac{(8.345(C_i V_i) + M_x)}{A}$$

Where:

M = Mass of nitrogen applied to LAA in lb/ac/yr;

C_i = Monthly average concentration of total nitrogen month i in mg/L;

V_i = Volume of wastewater applied to the LAA during calendar month i in millions gallons;

I = the number of the month (i.e., January = 1, February = 2, etc.);

A = Area of the LAA or field irrigated in acres; 8.345 = Unit conversion factor to transform mg/L to lbs/million gallons; and

M_x = Nitrogen mass from other sources (e.g., fertilizer and compost) in pounds.

3. **BOD₅ Loading Rate.** The maximum daily mass of BOD₅ applied to each LAA shall not exceed **300 pounds per acre per day (lbs/ac/day)** and shall be calculated using the following formula:

$$M = \frac{8.345(CV)}{A}$$

Where:

M = mass of BOD applied to an LAA in lb/ac/day;

C = concentration of BOD in mg/L based on most recent monitoring result;

V = volume of wastewater applied to the LAA in millions of gallons per day;

A = area of the LAA irrigated in acres; and

8.345 = unit conversion factor.

4. **Total Dissolved Solids (TDS) Trigger.** The Discharger shall calculate and submit the calendar annual average TDS concentration in the wastewater applied to the Land Application Areas, as measured at LND-001, with the Annual Report due 1 February each year. If the calendar annual average TDS concentration exceeds **600 mg/L**, this represents an increase over current performance-based discharge levels, and therefore the Discharger shall conduct an evaluation to determine the reason(s) for the increased TDS concentration and submit the evaluation by 1 May of that year. The evaluation shall include an explanation of the increased concentrations and the Discharger's determination if it represents an increase in mass loading of TDS to the Land Application Areas that would require an Antidegradation Analysis update to demonstrate the increased mass loading is consistent with the Antidegradation Policy. If the Executive Officer determines that an Antidegradation Analysis update is needed, then the Discharger shall submit the report within 90 days of the Executive Officer's written determination.
5. The discharge of waste classified as "hazardous" as defined in the California Code of Regulations, title 23, section 2510 et seq., is prohibited, and the discharge of waste classified as "designated", as defined in section 13173 of the Water Code, in a manner that causes violation of groundwater limitations is prohibited.
6. Discharge to the Land Application Areas shall not be performed during rainfall or when the ground is saturated.
7. The irrigation with recycled water shall be managed to minimize erosion within the use areas.

8. Stormwater runoff from the agricultural fields shall not be discharged to any surface waters or surface water drainage courses within thirty days of the last application of irrigation waters.
9. All tailwater shall be managed as described in the Fact Sheet.
10. Areas irrigated with effluent shall be managed to prevent breeding of mosquitoes. More specifically:
 - a. Maximize crop nutrient uptake.
 - b. Maximize breakdown of organic waste constituents in the root zone; and
 - c. Minimize the percolation of waste constituents below the root zone.
11. Land discharge of effluent shall comply with the following setback requirements:

Table 5. Land Discharge Specifications

Setback Definition	Minimum Irrigation Setback (feet)
Edge of land application area to property boundary	50
Edge of land application area to a public road	50
Edge of land application area to an irrigation well	100
Edge of land application area to a domestic water supply well	100
Edge of land application area to a manmade or natural surface water drainage course or spring	25

Table 5 Notes:

1. **Setback Definition.** As defined by the wetted area produced during irrigation.
2. **Natural Surface Water Drainage Course.** Excluding ditches used exclusively for tailwater return.

12. Undisinfected Secondary Recycled Water for Irrigation of Land Application Areas.
 - a. Recycled water shall be at least Undisinfected Secondary Treated Effluent as defined in Title 22, section 60301.
 - b. For the purpose of this Order, "use area" means an area with defined boundaries where recycled water is used or discharged.
 - c. Recycled water shall be used in compliance with Title 22, section 60304. Specifically, uses of recycled water shall be limited to those set forth in Title 22, section(s) 60304(a), 60304(b), 60304(c), and 60304(d).

- d. All recycled water equipment, pumps, piping, valves, and outlets shall be appropriately marked to differentiate them from potable facilities, and these shall be of a type, or secured in a manner, that permits operation by authorized personnel only.
- e. Use shall be limited to surface irrigation of fodder, fiber, and/or feed crops; No recycled water used for irrigation, or soil that has been irrigated with recycled water, shall come into contact with the edible portion of food crops that may be eaten raw by humans.
- f. Grazing of milking animals within the use areas is prohibited.
- g. Irrigation of the use areas shall occur only when appropriately trained personnel are on duty.
- h. Use areas shall be inspected as frequently as necessary to ensure continuous compliance with the requirements of this Order.

C. Recycling Specifications

- 1. Recycled water distribution from the Facility is separately regulated by Water Quality Order WQ 2016-0068-DDW, Water Reclamation Requirements for Recycled Water Use.
- 2. When producing Title 22 disinfected tertiary recycled water for use under Order WQ 2016-0068-DDW, the Discharger shall comply with the operating specifications per the accepted Title 22 Engineering Report as follows:
 - a. The turbidity of the filter effluent measured at FIL-001 shall not exceed:
 - i. 2 NTU as a daily average;
 - ii. 5 NTU more than 5 percent of the time within a 24-hour period; and
 - iii. 10 NTU, at any time.
 - b. The total coliform organisms in the effluent measured at REC-001 shall not exceed:
 - i. 2.2 most probable number (MPN) per 100 mL, as a 7-day median;
 - ii. 23 MPN/100 mL, more than once in any 30-day period; and
 - iii. 240 MPN/100 mL, at any time.

V. RECEIVING WATER LIMITATIONS

A. Surface Water Limitations - None

B. Groundwater Limitations

Release of waste constituents from any portion of the Facility shall not cause or contribute to groundwater containing any of the following constituents greater than listed below or greater than natural background quality, whichever is greater.

1. Total coliform organism level of 2.2 MPN/100 mL over any seven-day period.
2. Constituents in concentrations that exceed either the Primary or Secondary MCLs established in Title 22 of the California Code of Regulations, excluding salinity, provided the Discharger complies with Provision VI.C.3.b.
3. Contain taste or odor-producing constituents, toxic substances, or any other constituents in concentrations that cause nuisance or adversely affect beneficial uses, (e.g., by creating off-tastes and/or odor, producing detrimental physiological responses in human, plant, animal, or aquatic life [i.e., toxicity]).

VI. PROVISIONS

A. Standard Provisions

1. The Discharger shall comply with all Standard Provisions included in Attachment D.
2. The Discharger shall comply with the following provisions. In the event that there is any conflict, duplication, or overlap between provisions specified by this Order, the more stringent provision shall apply:
 - a. If the Discharger's wastewater treatment plant is publicly owned or subject to regulation by California Public Utilities Commission, it shall be supervised and operated by persons possessing certificates of appropriate grade according to Title 23, CCR, division 3, chapter 26.
 - b. After notice and opportunity for a hearing, this Order may be terminated or modified for cause, including, but not limited to:
 - i. violation of any term or condition contained in this Order;
 - ii. obtaining this Order by misrepresentation or by failing to disclose fully all relevant facts;
 - iii. a change in any condition that requires either a temporary or permanent reduction or elimination of the authorized discharge; and
 - iv. a material change in the character, location, or volume of discharge.

The causes for modification include:

- (a). New regulations. New regulations have been promulgated under section 405(d) of the CWA, or the standards or regulations on which the permit was based have been changed

by promulgation of amended standards or regulations or by judicial decision after the permit was issued.

- (b). Land application plans. When required by a permit condition to incorporate a land application plan for beneficial reuse of sewage sludge, to revise an existing land application plan, or to add a land application plan.
- (c). Change in sludge use or disposal practice. Under 40 CFR section 122.62(a)(1), a change in the Discharger's sludge use or disposal practice is a cause for modification of the permit. It is cause for revocation and reissuance if the Discharger requests or agrees.

The Central Valley Water Board may review and revise this Order at any time upon application of any affected person or the Central Valley Water Board's own motion.

- c. If a toxic effluent standard or prohibition (including any scheduled compliance specified in such effluent standard or prohibition) is established under section 307(a) of the CWA, or amendments thereto, for a toxic pollutant that is present in the discharge authorized herein, and such standard or prohibition is more stringent than any limitation upon such pollutant in this Order, the Central Valley Water Board will revise or modify this Order in accordance with such toxic effluent standard or prohibition.

The Discharger shall comply with effluent standards and prohibitions within the time provided in the regulations that establish those standards or prohibitions, even if this Order has not yet been modified.

- d. This Order shall be modified, or alternately revoked and reissued, to comply with any applicable effluent standard or limitation issued or approved under sections 301(b)(2)(C) and (D), 304(b)(2), and 307(a)(2) of the CWA, if the effluent standard or limitation so issued or approved:
 - i. Contains different conditions or is otherwise more stringent than any effluent limitation in the Order; or
 - ii. Controls any pollutant limited in the Order.

The Order, as modified or reissued under this paragraph, shall also contain any other requirements of the CWA then applicable.

- e. The provisions of this Order are severable. If any provision of this Order is found invalid, the remainder of this Order shall not be affected.

- f. The Discharger shall take all reasonable steps to minimize any adverse effects to waters of the State or users of those waters resulting from any discharge or sludge use or disposal in violation of this Order. Reasonable steps shall include such accelerated or additional monitoring as necessary to determine the nature and impact of the non-complying discharge or sludge use or disposal.
- g. The Discharger shall ensure compliance with any existing or future pretreatment standard promulgated by U.S. EPA under section 307 of the CWA, or amendment thereto, for any discharge to the municipal system.
- h. A copy of this Order shall be maintained at the discharge facility and be available at all times to operating personnel. Key operating personnel shall be familiar with its content.
- i. Safeguard to electric power failure:
 - i. The Discharger shall provide safeguards to assure that, should there be reduction, loss, or failure of electric power, the discharge shall comply with the terms and conditions of this Order.
 - ii. Upon written request by the Central Valley Water Board, the Discharger shall submit a written description of safeguards. Such safeguards may include alternate power sources, standby generators, retention capacity, operating procedures, or other means. A description of the safeguards provided shall include an analysis of the frequency, duration, and impact of power failures experienced over the past 5 years on effluent quality and on the capability of the Discharger to comply with the terms and conditions of the Order. The adequacy of the safeguards is subject to the approval of the Central Valley Water Board.
 - iii. Should the treatment works not include safeguards against reduction, loss, or failure of electric power, or should the Central Valley Water Board not approve the existing safeguards, the Discharger shall, within 90 days of having been advised in writing by the Central Valley Water Board that the existing safeguards are inadequate, provide to the Central Valley Water Board and U.S. EPA a schedule of compliance for providing safeguards such that in the event of reduction, loss, or failure of electric power, the Discharger shall comply with the terms and conditions of this Order. The schedule of compliance shall, upon approval of the Central Valley Water Board, become a condition of this Order.
- j. The Discharger, upon written request of the Central Valley Water Board, shall file with the Board a technical report on its preventive (failsafe) and contingency (cleanup) plans for controlling accidental discharges, and for minimizing the effect of such events. This report may be combined with

that required under the Central Valley Water Board Standard Provision contained in section VI.A.2.i of this Order.

The technical report shall:

- i. Identify the possible sources of spills, leaks, untreated waste by-pass, and contaminated drainage. Loading and storage areas, power outage, waste treatment unit outage, and failure of process equipment, tanks and pipes should be considered.
- ii. Evaluate the effectiveness of present facilities and procedures and state when they became operational.
- iii. Predict the effectiveness of the proposed facilities and procedures and provide an implementation schedule containing interim and final dates when they will be constructed, implemented, or operational.

The Central Valley Water Board, after review of the technical report, may establish conditions which it deems necessary to control accidental discharges and to minimize the effects of such events. Such conditions shall be incorporated as part of this Order, upon notice to the Discharger.

- k. A publicly owned treatment works whose waste flow has been increasing, or is projected to increase, shall estimate when flows will reach hydraulic and treatment capacities of its treatment and disposal facilities. The projections shall be made in January, based on the last 3 years' average dry weather flows, peak wet weather flows and total annual flows, as appropriate. When any projection shows that capacity of any part of the facilities may be exceeded in 4 years, the Discharger shall notify the Central Valley Water Board by 31 January. A copy of the notification shall be sent to appropriate local elected officials, local permitting agencies and the press. Within 120 days of the notification, the Discharger shall submit a technical report showing how it will prevent flow volumes from exceeding capacity or how it will increase capacity to handle the larger flows. The Central Valley Water Board may extend the time for submitting the report.
- l. The Discharger shall submit technical reports as directed by the Executive Officer. All technical reports required herein that involve planning, investigation, evaluation, or design, or other work requiring interpretation and proper application of engineering or geologic sciences, shall be prepared by or under the direction of persons registered to practice in California pursuant to California Business and Professions Code, sections 6735, 7835, and 7835.1. To demonstrate compliance with Title 16, CCR, sections 415 and 3065, all technical reports must contain a statement of the qualifications of the responsible registered professional(s). As required by these laws, completed technical reports must bear the signature(s) and seal(s) of the registered professional(s) in a manner such that all work can be clearly attributed to the professional responsible for the work.

- m. The Central Valley Water Board is authorized to enforce the terms of this permit under several provisions of the Water Code, including, but not limited to, sections 13385, 13386, and 13387.
- n. In the event of any change in control or ownership of land or waste discharge facilities presently owned or controlled by the Discharger, the Discharger shall notify the succeeding owner or operator of the existence of this Order by letter, a copy of which shall be immediately forwarded to the Central Valley Water Board.
- o. This Order may be reopened to transfer ownership of control of this Order. The succeeding owner or operator must apply in writing requesting transfer of the Order. The request must contain the requesting entity's full legal name, the state of incorporation if a corporation, address and telephone number of the persons responsible for contact with the Central Valley Water Board, and a statement. The statement shall comply with the signatory and certification requirements in the federal Standard Provisions (Attachment D, section V.B) and state that the new owner or operator assumes full responsibility for compliance with this Order.
- p. If the Discharger submits a timely and complete ROWD for permit reissuance, this permit shall continue in force and effect until the permit is reissued or the Regional Water Board rescinds the permit.
- q. Failure to comply with provisions or requirements of this Order, or violation of other applicable laws or regulations governing discharges from this facility, may subject the Discharger to administrative or civil liabilities, criminal penalties, and/or other enforcement remedies to ensure compliance. Additionally, certain violations may subject the Discharger to civil or criminal enforcement from appropriate local, state, or federal law enforcement entities.
- r. In the event the Discharger does not comply or will be unable to comply for any reason, with any prohibition, effluent limitation, or receiving water limitation of this Order, the Discharger shall notify the Central Valley Water Board by telephone (916) 464-3291 within 24 hours of having knowledge of such noncompliance, and shall confirm this notification in writing within five days, unless the Central Valley Water Board waives confirmation. The written notification shall state the nature, time, duration, and cause of noncompliance, and shall describe the measures being taken to remedy the current noncompliance and prevent recurrence including, where applicable, a schedule of implementation. Other noncompliance requires written notification as above at the time of the normal monitoring report.

B. Monitoring and Reporting Program (MRP) Requirements

The Discharger shall comply with the MRP, and future revisions thereto, in Attachment E.

C. Special Provisions

1. Reopener Provisions

- a. Conditions that necessitate a major modification of a permit are described in 40 CFR section 122.62, including, but not limited to:
 - i. If new or amended applicable water quality standards are promulgated or approved pursuant to section 303 of the CWA, or amendments thereto, this permit may be reopened and modified in accordance with the new or amended standards.
 - ii. When new information, that was not available at the time of permit issuance, would have justified different permit conditions at the time of issuance.
- b. This Order may be reopened for modification, or revocation and reissuance, as a result of the detection of a reportable priority pollutant generated by special conditions included in this Order. These special conditions may be, but are not limited to, fish tissue sampling, whole effluent toxicity, monitoring requirements on internal waste stream(s), and monitoring for surrogate parameters. Additional requirements may be included in this Order as a result of the special condition monitoring data.
- c. **Mercury.** The Basin Plan's Delta Mercury Control Program was designed to proceed in two phases. The Delta Mercury Control Program is in Phase 2, and the Central Valley Water Board is conducting a Phase 1 Delta Mercury Control Program Review that considers modification to the Delta Mercury Control Program. This Order may be reopened to address changes to the Delta Mercury Control Program.
- d. **Pollution Prevention.** This Order requires the Discharger prepare pollution prevention plans following Water Code section 13263.3(d)(3) for mercury. Based on a review of the pollution prevention plans, this Order may be reopened for addition and/or modification of effluent limitations and requirements for these constituents.
- e. **Water Effects Ratios (WER) and Metal Translators.** A default WER of 1.0 has been used in this Order for calculating criteria for applicable inorganic constituents. In addition, default dissolved-to-total metal translators have been used to convert water quality objectives from dissolved to total. If the Discharger performs studies to determine site-specific WERs and/or site-specific dissolved-to-total metal translators, this Order may be reopened to modify the effluent limitations for the applicable inorganic constituents.
- f. **Ultraviolet (UV) Disinfection Operating Specifications.** The UV operating specifications in this Order are based on the UV guidelines

developed by the National Water Research Institute and American Water Works Association Research Foundation titled, "Ultraviolet Disinfection Guidelines for Drinking Water and Water Reuse." If the Discharger conducts a site-specific UV engineering study that identifies site-specific UV operating specifications that will achieve the virus inactivation equivalent to Title 22 disinfected tertiary recycled water, this Order may be reopened to modify the UV operating specifications.

- g. **Central Valley Salinity Alternatives for Long-Term Sustainability (CV-SALTS).** On 17 January 2020, certain Basin Plan Amendments to incorporate new strategies for addressing ongoing salt and nitrate accumulation in the Central Valley became effective. Other provisions subject to U.S. EPA approval became effective on 2 November 2020, when approved by U.S. EPA. As the Central Valley Water Board moves forward to implement those provisions that are now in effect, this Order may be amended or modified to incorporate new or modified requirements necessary for implementation of the Basin Plan Amendments. More information regarding these Amendments can be found on the [Central Valley Salinity Alternatives for Long-Term Sustainability \(CV-SALTS\) web page](https://www.waterboards.ca.gov/centralvalley/water_issues/salinity/):
(https://www.waterboards.ca.gov/centralvalley/water_issues/salinity/)
- h. **Phase IV Stage 2 Improvements (17.5 MGD).** The Discharger has requested an expansion of allowable flows to be discharged to the San Joaquin River. The Order may be reopened to modify the permitted average dry weather flow discharge up to 17.5 MGD upon compliance with the following conditions:
- i. **Facility Improvements.** The Discharger shall have completed construction of its Phase IV stage 2 improvements, which may include an additional influent pump, new aerated grit tanks, new sedimentation basins, membrane bioreactors, an additional centrifuge, new rotating drum thickeners, and an additional digester and expansion of the Digester Control Building. The Discharger shall provide certification of completion by the design engineer.
- ii. **Effluent and Receiving Water Limitation Compliance.** The certification of completion submitted by the Discharger shall certify that the upgraded Facility can meet the requirements of sections IV.A.1, IV.A.2, and V.B of this Order and that the upgraded Facility can accommodate and dewater the increased sludge volume.
- iii. **Request for Flow Increase.** The Discharger shall submit a request for an increase in the permitted discharge flow rate, which demonstrates compliance with items i and ii of this provision.
- i. **Whole Effluent Toxicity.**

- i. This Order may be reopened for modification to revise the aquatic toxicity provisions if the Supreme Court determines that the test of significant toxicity cannot be used in NPDES permits and the State Water Board suspends or revises the aquatic toxicity water quality standards.
- ii. If after review of new data and information, it is determined that the discharge has reasonable potential to cause or contribute to an instream exceedance of the Statewide Toxicity Provisions' numeric chronic aquatic toxicity objective and Basin Plan's narrative toxicity objective this Order may be reopened and effluent limitations added for acute and/or chronic toxicity.
- j. **Bay-Delta Plan.** On 25 February 2019, the California Office of Administrative Law approved the 2018 Bay-Delta Plan amendments, which include a numeric water quality objective (WQO) for the San Joaquin River at Vernalis of 1,000 $\mu\text{mhos/cm}$ maximum, year-round, applied as a 30-day running average of mean daily electrical conductivity. Once approved by the United States Environmental Protection Agency (U.S. EPA), the revised WQO will be applicable to the San Joaquin River at Vernalis and this Order may be amended or modified to implement the Bay-Delta Plan WQOs.
- k. **Mixing Zone/Dilution Credit Study for Ammonia.** This Order may be reopened to include information regarding a mixing zone and dilution credits study for ammonia and to revise effluent limitations for ammonia based on the results of the study.

2. Special Studies, Technical Reports and Additional Monitoring Requirements

a. Toxicity Reduction Evaluation (TRE) Requirements.

- i. **TRE:** The Discharger is required to conduct a TRE, as detailed in the Monitoring and Reporting Program (Attachment E, Section V.G), when any combination of two or more **MDEL or MMEL** violations occur within a single toxicity calendar month or within two successive toxicity calendar months. In addition, if other information indicates toxicity (e.g., results of additional monitoring, results of monitoring at a higher concentration than the IWC, fish kills, intermittent recurring toxicity) or if there is no effluent available to complete a routine monitoring test or **MMEL** compliance test, the Executive Officer may require a TRE

3. Best Management Practices and Pollution Prevention

- a. **Pollution Prevention Plan for Mercury.** The Discharger shall continue to implement a pollution prevention plan for mercury in accordance with Water Code section 13263.3(d)(3), per the compliance schedule in this

Order for methylmercury (section VI.C.7.a), and further described in the Fact Sheet. The minimum requirements for the pollution prevention plan are outlined in the Fact Sheet (Attachment F, section VI.B.3.a). Progress reports shall be submitted in accordance with the Monitoring and Reporting Program Technical Reports Table E-13 and may be submitted with the Annual Operations Report. The progress reports shall discuss the effectiveness of the pollution prevention plan in the reduction of mercury in the discharge, include a summary of mercury and methylmercury monitoring results, and discuss updates to the pollution prevention plan.

- b. **Salinity Evaluation and Minimization Plan (SEMP).** The Discharger shall continue to implement a SEMP to identify and address sources of salinity discharged from the Facility.

The Discharger submitted a Notice of Intent to comply with the Salt Control Program and selected the Alternative Permitting Approach. Accordingly, the Discharger shall participate in the CV-SALTS Prioritization and Optimization (P&O) Study. Furthermore, an evaluation of the effectiveness of the SEMP shall be submitted with the ROWD. The evaluation shall include, at minimum, the calendar annual average concentrations of effluent electrical conductivity during the term of the Order. If the average electrical conductivity concentration for any calendar year exceeds a performance-based **trigger of 1,000 µmhos/cm**, the Discharger shall evaluate possible sources of salinity contributing to the exceedance of the trigger and update the SEMP to include a plan of action to control salinity.

4. Construction, Operation and Maintenance Specifications

- a. **Filtration System Operating Specifications.** When discharging to the San Joaquin River, To ensure the filtration system is operating properly to provide adequate disinfection of the wastewater, the turbidity of the filter effluent measured at Monitoring Location FIL-001 shall not exceed:
 - i. 2 NTU as a daily average;
 - ii. 5 NTU more than 5 percent of the time within a 24-hour period; and
 - iii. 10 NTU, at any time.
- b. **UV Disinfection System Operating Specifications.** The UV disinfection system must be operated in accordance with an operations and maintenance program that assures adequate disinfection, and shall meet the following minimum specifications to provide virus inactivation equivalent to Title 22 Disinfected Tertiary Recycled Water:
 - i. **UV Dose.** The minimum hourly average UV dose in the UV reactor shall be 100 millijoules per square centimeter (mJ/cm^2).

- ii. **UV Transmittance.** The minimum hourly average UV transmittance (at 254 nanometers) in the wastewater measured at UVS-001 shall not fall below 55 percent.
 - iii. The lamp sleeves and cleaning system components must be visually inspected per the manufacturer's operations manual for physical wear (scoring, solarization, seal leaks, cleaning fluid levels, etc.) and to check the efficacy of the cleaning system.
 - iv. The lamp sleeves must be cleaned periodically as necessary to meet the UV dose requirements.
 - v. Lamps must be replaced per the manufacturer's operations manual, or sooner, if there are indications the lamps are failing to provide adequate disinfection. Lamp age and lamp replacement records must be maintained.
- c. **Treatment Pond Operating Requirements.** Unless otherwise specified, the following requirements are applicable to ponds PND-001 (Secondary Effluent Storage Pond), PND-002 (Food Processing Pond), and PND-003 (Secondary Effluent Equalization Pond):
- i. No waste constituent shall be released, discharged, or placed where it will cause a violation of the Groundwater Limitations of this Order.
 - ii. Wastewater treatment, storage, and disposal shall not cause pollution or a nuisance as defined by Water Code section 13050.
 - iii. Public contact with wastewater shall be precluded through such means as fences, signs, and other acceptable alternatives.
 - iv. Ponds shall be managed to prevent breeding of mosquitoes. In particular, (a) An erosion control program should assure that small coves and irregularities are not created around the perimeter of the water surface. (b) Weeds shall be minimized. (c) Dead algae, vegetation, and debris shall not accumulate on the water surface.
 - v. Freeboard shall never be less than 2 feet (measured vertically to the lowest point of overflow) as a monthly average and never less than 1 foot at any time.
 - vi. Objectionable odors shall not be perceivable beyond the limits of the Facility property at an intensity that creates or threatens to create nuisance conditions.
 - vii. As a means of discerning compliance with Specification c.iv, the dissolved oxygen (DO) content in the upper one foot of any wastewater treatment or storage pond shall not be less than 1.0 mg/L

for three consecutive weekly sampling events. If the DO in any single pond is below 1.0 mg/L for three consecutive sampling events, the Discharger shall report the findings to the Central Valley Water Board in writing within 10 days and shall include a specific plan to resolve the low DO results within 30 days.

- viii. The treatment ponds shall be designed, constructed, operated, and maintained to prevent inundation or washout due to floods with a 100-year return frequency.

5. Special Provisions for Publicly-Owned Treatment Works (POTWs)

a. Pretreatment Requirements

- i. The Discharger shall be responsible and liable for the performance of all Control Authority pretreatment requirements contained in 40 C.F.R. Part 403, including any subsequent regulatory revisions to 40 C.F.R. Part 403. Where 40 C.F.R. Part 403 or subsequent revision places mandatory actions upon the Discharger as Control Authority but does not specify a timetable for completion of the actions, the Discharger shall complete the required actions within 6 months from the issuance date of this permit or the effective date of the 40 CFR Part 403 revisions, whichever comes later. For violations of pretreatment requirements, the Discharger shall be subject to enforcement actions, penalties, fines, and other remedies by U.S. EPA or other appropriate parties, as provided in the CWA. U.S. EPA may initiate enforcement action against a nondomestic user for noncompliance with applicable standards and requirements as provided in the CWA.
- ii. The Discharger shall enforce the requirements promulgated under sections 307(b), 307(c), 307(d), and 402(b) of the CWA with timely, appropriate and effective enforcement actions. The Discharger shall cause all nondomestic users subject to federal categorical standards to achieve compliance no later than the date specified in those requirements or, in the case of a new nondomestic user, upon commencement of the discharge.
- iii. The Discharger shall perform the pretreatment functions as required in 40 C.F.R. Part 403 including, but not limited to:
 - (a) Implement the necessary legal authorities as provided in 40 CFR Part 403.8(f)(1);
 - (b) Enforce the pretreatment requirements under 40 C.F.R. sections 403.5 and 403.6;
 - (c) Implement the programmatic functions as provided in 40 C.F.R. section 403.8(f)(2); and

- (d) Provide the requisite funding and personnel to implement the pretreatment program as provided in 40 C.F.R. section 403.8(f)(3).
- iv. **Pretreatment Reporting Requirements.** Pretreatment reporting requirements are included in the Monitoring and Reporting Program, section X.D.5 of Attachment E.
- v. **Local Limits Evaluation.** In accordance with 40 C.F.R. section 122.44(j)(2)(ii) the Discharger shall provide a written technical evaluation of the need to revise the local limits under 40 C.F.R. section 403.5(c)(1) with the Report of Waste Discharge.
- b. **Sludge/Biosolids Treatment or Discharge Specifications.** Sludge in this document means the solid, semisolid, and liquid residues removed during primary, secondary, or advanced wastewater treatment processes. Solid waste refers to grit and screening material generated during preliminary treatment. Residual sludge means sludge that will not be subject to further treatment at the wastewater treatment plant. Biosolids refer to sludge that has been treated and tested and shown to be capable of being beneficially and legally used pursuant to federal and state regulations as a soil amendment for agricultural, silvicultural, horticultural, and land reclamation activities as specified under 40 C.F.R. Part 503.
 - i. Collected screenings, residual sludge, biosolids, and other solids removed from liquid wastes shall be disposed of in a manner consistent with Consolidated Regulations for Treatment, Storage, Processing, or Disposal of Solid Waste, as set forth in Title 27, CCR, division 2, subdivision 1, section 20005, et seq. Removal for further treatment, storage, disposal, or reuse at sites (e.g., landfill, composting sites, soil amendment sites) that are operated in accordance with valid waste discharge requirements issued by a Regional Water Board will satisfy these specifications.

Sludge and solid waste shall be removed from screens, sumps, ponds, clarifiers, etc. as needed to ensure optimal plant performance.

The treatment of sludge generated at the Facility shall be confined to the Facility property and conducted in a manner that precludes infiltration of waste constituents into soils in a mass or concentration that will violate groundwater limitations in section V.B. of this Order. In addition, the storage of residual sludge, solid waste, and biosolids on Facility property shall be temporary and controlled, and contained in a manner that minimizes leachate formation and precludes infiltration of waste constituents into soils in a mass or concentration that will violate groundwater limitations included in section V.B. of this Order.

- ii. The use, disposal, storage, and transportation of biosolids shall comply with existing federal and state laws and regulations, including permitting requirements and technical standards included in 40 C.F.R. Part 503. If the State Water Board and the Central Valley Water Board are given the authority to implement regulations contained in 40 C.F.R. Part 503, this Order may be reopened to incorporate appropriate time schedules and technical standards. The Discharger must comply with the standards and time schedules contained in 40 C.F.R. Part 503 whether or not they have been incorporated into this Order.
- iii. The Discharger shall comply with section IX.A. Biosolids of the Monitoring and Reporting Program, Attachment E.
- iv. The Discharger shall implement onsite sludge/biosolids treatment, processing, and storage for the Facility as described in the Fact Sheet (Attachment F, section II.A). This Order may be reopened to address any proposed change in the onsite treatment, processing, or storage of sludge/biosolids.

6. Other Special Provisions

- a. **Disinfection Requirements.** Wastewater shall be oxidized, coagulated, filtered, and adequately disinfected consistent with the State Water Board, Division of Drinking Water (DDW) reclamation criteria, CCR, Title 22, division 4, chapter 3, (Title 22), or equivalent.
- b. **CV-SALTS.** The Discharger shall comply with the applicable provisions of the Salt and Nitrate Control Programs adopted in Resolution R5-2018-0034 (as revised per Resolution R5-2020-0057) to address ongoing salt and nitrate accumulation in the Central Valley developed as part of the CV-SALTS initiative.
- c. **Discharge Flow Increase (12.87 MGD).** Phase IV stage 1 improvements may include construction of new influent flow meters, new influent pump, new aerated grit tanks, new sedimentation basins, new membrane bioreactors, and an additional digester. Before initiating average dry weather flows greater than 9.87 MGD, the Discharger shall provide certification of completion of Phase IV stage 1 improvements by the design engineer. The certification of completion submitted by the design engineer shall certify that the upgraded Facility can meet the requirements of sections IV.A.1, IV.A.2, and V.B of this Order and that the upgraded Facility can accommodate and dewater the increased sludge volume.

7. Compliance Schedules

- a. **Compliance Schedules for Final Effluent Limitations for Methylmercury.** This Order requires compliance with the final effluent limitations for methylmercury by 31 December 2030. The Discharger shall

comply with the time schedule shown in the Technical Reports Table E-13 to ensure compliance with the final effluent limitations. Additional information regarding the compliance schedule, including completed tasks during the previous permit term, is described in the Fact Sheet (Attachment F, Section VI.B.7).

VII. COMPLIANCE DETERMINATION

- A. Average Dry Weather Flow Prohibition (section III.E).** The average dry weather discharge flow represents the daily average flow when groundwater is at or near normal and runoff is not occurring. Compliance with the average dry weather flow discharge prohibition will be determined annually based on the average daily flow over three consecutive dry weather months (e.g., July, August, and September).
- B. BOD₅ and TSS Effluent Limitations (sections IV.A.1.a and IV.A.1.f).** Compliance with the final effluent limitations for BOD₅ and TSS required in WDR section IV.A.1.a shall be ascertained by 24-hour composite samples. Compliance with effluent limitations required in WDR section IV.A.1.f for percent removal shall be calculated using the arithmetic mean of BOD₅ and TSS in effluent samples collected over a monthly period as a percentage of the arithmetic mean of the values for influent samples collected at approximately the same times during the same period.
- C. Whole Effluent Toxicity Effluent Limitations.** The discharge is subject to determination of “Pass” or “Fail” from chronic whole effluent toxicity tests using the Test of Significant Toxicity (TST) statistical t-test approach described in *National Pollutant Discharge Elimination System Test of Significant Toxicity Implementation Document* (EPA 833-R-10-003, 2010), Appendix A, Figure A-1 and Table A-1 (Chronic Freshwater and East Coast Methods) and Appendix B, Table B-1.

The null hypothesis (H₀) for the TST statistical approach is:

Mean discharge Instream Waste Concentration (IWC) response \leq Regulatory Management Decision (RMD) x Mean control response, where the chronic RMD = 0.75.

A test result that rejects this null hypothesis is reported as “Pass.” A test result that does not reject this null hypothesis is reported as “Fail.”

The relative “Percent Effect” at the discharge IWC is defined and reported as:

Percent Effect = ((Mean control response – Mean discharge IWC response) / Mean control response) x 100.

This is a t-test (formally Student’s t-Test), a statistical analysis comparing two sets of replicate observations, i.e., a control and IWC. The purpose of this statistical test is to determine if the means of the two sets of observations are different (i.e., if the IWC differs from the control, the test result is “Fail”). The

Welch's t-test employed by the TST statistical approach is an adaptation of Student's t-test and is used with two samples having unequal variances.

1. **Chronic Whole Effluent Toxicity MDEL (section IV.A.1.b).** If the result of a routine water flea (*Ceriodaphnia dubia*) chronic whole effluent toxicity test, using the TST statistical approach, is a "Fail" at the IWC for the sublethal endpoint measured in the test and the percent effect for the survival endpoint is greater than or equal to 50 percent, the Discharger will be deemed out of compliance with the MDEL.
2. **Chronic Whole Effluent Toxicity MMEL (section IV.A.1.c).** If a routine *Ceriodaphnia dubia* chronic whole effluent toxicity test and at least one *Ceriodaphnia dubia* chronic toxicity MMEL compliance test conducted within the same toxicity calendar month result in a "Fail" at the IWC, using the TST statistical approach, the Discharger will be deemed out of compliance with the MMEL.

If the Discharger conducts chronic whole effluent toxicity split sampling with accredited laboratories, the Discharger shall designate which sample shall be used to determine compliance with chronic toxicity effluent limitations.

- D. **Chlorpyrifos and Diazinon Effluent Limitations (section IV.A.1.d).** Compliance shall be determined by calculating the sum (S), as provided in section IV.A.1.d of this Order, with analytical results that are reported as ND concentrations to be considered to be zero.
- E. **Total Mercury and Methylmercury Mass Loading Effluent Limitations (section IV.A.1.e and IV.A.2.a).** The procedures for calculating mass loadings are as follows:
 1. The total pollutant mass load for each individual calendar month shall be determined using an average of all concentration data collected that month and the corresponding total monthly flow. All effluent monitoring data collected under the monitoring and reporting program, pretreatment program, and any special studies shall be used for these calculations. The total annual mass loading shall be the sum of the individual calendar months.
 2. In calculating compliance, the Discharger shall count all non-detect measures at one-half of the detection level. If compliance with the effluent limitation is not attained due to the non-detect contribution, the Discharger shall improve and implement available analytical capabilities and compliance shall be evaluated with consideration of the detection limits.
- F. **Temperature Effluent Limitation (Section IV.A.1.h).** Compliance with the effluent limitation for temperature shall be ascertained using the daily average effluent temperature at Monitoring Location EFF-001 and the temperature of the "upstream" receiving water measured on the same day by grab sample at either Monitoring Location RSW-001 or Monitoring Location RSW-002, depending on the direction of the San Joaquin River flow at the time of sampling. Due to the tidal nature of the

receiving water, the direction of the San Joaquin River flow at the time of sampling will dictate which monitoring location is representative of the “upstream” receiving water.

G. Total Coliform Organisms Effluent Limitations (section IV.A.1.i). For each day that an effluent sample is collected and analyzed for total coliform organisms, the 7-day median shall be determined by calculating the median concentration of total coliform bacteria in the effluent utilizing the bacteriological results of the last 7 days. For example, if a sample is collected on a Wednesday, the result from that sampling event and all results from the previous 6 days (i.e., Tuesday, Monday, Sunday, Saturday, Friday, and Thursday) are used to calculate the 7-day median. If the 7-day median of total coliform organisms exceeds a most probable number (MPN) of 2.2 per 100 milliliters, the Discharger will be considered out of compliance.

H. Mass Effluent Limitations. The mass effluent limitations contained in the Final Effluent Limitations IV.A.1.a are based on the permitted average dry weather flow and calculated as follows:

$$\text{Mass (lbs/day)} = \text{Flow (MGD)} \times \text{Concentration (mg/L)} \times 8.34 \text{ (conversion factor)}$$

If the effluent flow exceeds the permitted average dry weather flow during wet-weather seasons, the effluent mass limitations contained in Final Effluent Limitations IV.A.1.a shall not apply.

I. Priority Pollutant Effluent Limitations. Compliance with effluent limitations for priority pollutants shall be determined in accordance with section 2.4.5 of the SIP, as follows:

1. Dischargers shall be deemed out of compliance with an effluent limitation, if the concentration of the priority pollutant in the monitoring sample is greater than the effluent limitation and greater than or equal to the reporting level (RL).
2. Dischargers shall be required to conduct a Pollutant Minimization Program (PMP) in accordance with section 2.4.5.1 of the SIP when there is evidence that the priority pollutant is present in the effluent above an effluent limitation and either:
 - a. sample result is reported as detected, but not quantified (DNQ) and the effluent limitation is less than the RL; or
 - b. sample result is reported as non-detect (ND) and the effluent limitation is less than the method detection limit (MDL).
3. When determining compliance with an average monthly effluent limitation (AMEL) and more than one sample result is available in a month, the discharger shall compute the arithmetic mean unless the data set contains one or more reported determinations of DNQ or ND. In those cases, the discharger shall compute the median in place of the arithmetic mean in accordance with the following procedure:

- a. The data set shall be ranked from low to high, reported ND determinations lowest, DNQ determinations next, followed by quantified values (if any). The order of the individual ND or DNQ determinations is unimportant.
 - b. The median value of the data set shall be determined. If the data set has an odd number of data points, then the median is the middle value. If the data set has an even number of data points, then the median is the average of the two values around the middle unless one or both of the points are ND or DNQ, in which case the median value shall be the lower of the two data points where DNQ is lower than a value and ND is lower than DNQ.
4. If a sample result, or the arithmetic mean or median of multiple sample results, is below the RL, and there is evidence that the priority pollutant is present in the effluent above an effluent limitation and the discharger conducts a PMP (as described in section 2.4.5.1), the discharger shall **not** be deemed out of compliance.

ATTACHMENT A – DEFINITIONS

1Q10

The lowest one-day flow with an average reoccurrence frequency of once in ten years.

7Q10

The lowest average seven consecutive day flow with an average reoccurrence frequency of once in ten years.

Acute Aquatic Toxicity Test

A test to determine an adverse effect (usually lethality) on a group of aquatic test organisms during a short-term exposure (e.g., 24, 48, or 96 hours).

Alternative Hypothesis

A statement used to propose a statistically significant relationship in a set of given observations. Under the TST approach, when the Null Hypothesis is rejected, the Alternative Hypothesis is accepted in its place, indicating a relationship between variables and an acceptable level of toxicity.

Arithmetic Mean (μ)

Also called the average, is the sum of measured values divided by the number of samples. For ambient water concentrations, the arithmetic mean is calculated as follows:

$$\text{Arithmetic mean} = \mu = \Sigma x / n$$

where: Σx is the sum of the measured ambient water concentrations, and n is the number of samples.

Average Monthly Effluent Limitation (AMEL)

The highest allowable average of daily discharges over a calendar month, calculated as the sum of all daily discharges measured during a calendar month divided by the number of daily discharges measured during that month.

Average Weekly Effluent Limitation (AWEL)

The highest allowable average of daily discharges over a calendar week (Sunday through Saturday), calculated as the sum of all daily discharges measured during a calendar week divided by the number of daily discharges measured during that week.

Best Management Practices (BMPs)

Methods, measures, or practices designed and selected to reduce or eliminate the discharge of pollutants to surface waters from point and nonpoint source discharges including storm water. BMPs include structural and non-structural controls, and operation and maintenance procedures, which can be applied before, during, and/or after pollution producing activities.

Bioaccumulative

Those substances taken up by an organism from its surrounding medium through gill membranes, epithelial tissue, or from food and subsequently concentrated and retained in the body of the organism.

Calendar Month

A period of time from of the first of a month to the last day of the month (e.g., from January 1 to January 31, from April 1 to April 30, or from December 1 to December 31).

Calendar Quarter

A period of time defined as three consecutive calendar months (e.g., from January 1 to March 31, from April 1 to June 30, or from October 1 to December 31).

Calendar Year

A period of time defined as twelve consecutive calendar months (i.e., January 1 to December 31).

Chronic Aquatic Toxicity Test

A test to determine an adverse effect (sub-lethal or lethal) on a group of aquatic test organisms during an exposure of duration long enough to assess sub-lethal effects.

Carcinogenic

Pollutants are substances that are known to cause cancer in living organisms.

Coefficient of Variation (CV)

CV is a measure of the data variability and is calculated as the estimated standard deviation divided by the arithmetic mean of the observed values.

Daily Discharge

Daily Discharge is defined as either: (1) the total mass of the constituent discharged over the calendar day (12:00 am through 11:59 pm) or any 24-hour period that reasonably represents a calendar day for purposes of sampling (as specified in the permit), for a constituent with limitations expressed in units of mass or; (2) the unweighted arithmetic mean measurement of the constituent over the day for a constituent with limitations expressed in other units of measurement (e.g., concentration).

The daily discharge may be determined by the analytical results of a composite sample taken over the course of one day (a calendar day or other 24-hour period defined as a day) or by the arithmetic mean of analytical results from one or more grab samples taken over the course of the day.

For composite sampling, if 1 day is defined as a 24-hour period other than a calendar day, the analytical result for the 24-hour period will be considered as the result for the calendar day in which the 24-hour period ends.

Detected, but Not Quantified (DNQ)

DNQ are those sample results less than the RL, but greater than or equal to the laboratory's MDL. Sample results reported as DNQ are estimated concentrations.

Dilution Credit

Dilution Credit is the amount of dilution granted to a discharge in the calculation of a water quality-based effluent limitation, based on the allowance of a specified mixing zone. It is calculated from the dilution ratio or determined through conducting a mixing zone study or modeling of the discharge and receiving water.

Effluent Concentration Allowance (ECA)

ECA is a value derived from the water quality criterion/objective, dilution credit, and ambient background concentration that is used, in conjunction with the coefficient of variation for the effluent monitoring data, to calculate a long-term average (LTA) discharge concentration. The ECA has the same meaning as waste load allocation (WLA) as used in U.S. EPA guidance (Technical Support Document For Water Quality-based Toxics Control, March 1991, second printing, EPA/505/2-90-001).

Enclosed Bays

Enclosed Bays means indentations along the coast that enclose an area of oceanic water within distinct headlands or harbor works. Enclosed bays include all bays where the narrowest distance between the headlands or outermost harbor works is less than 75 percent of the greatest dimension of the enclosed portion of the bay. Enclosed bays include, but are not limited to, Humboldt Bay, Bodega Harbor, Tomales Bay, Drake's Estero, San Francisco Bay, Morro Bay, Los Angeles-Long Beach Harbor, Upper and Lower Newport Bay, Mission Bay, and San Diego Bay. Enclosed bays do not include inland surface waters or ocean waters.

Endpoint

An effect that is measured in a toxicity study. Endpoints in toxicity tests may include, but are not limited to survival, reproduction, and growth. A measured response of a receptor to a stressor. An endpoint can be measured in a toxicity test or field survey.

Estimated Chemical Concentration

The estimated chemical concentration that results from the confirmed detection of the substance by the analytical method below the ML value.

Estuaries

Estuaries means waters, including coastal lagoons, located at the mouths of streams that serve as areas of mixing for fresh and ocean waters. Coastal lagoons and mouths of streams that are temporarily separated from the ocean by sandbars shall be considered estuaries. Estuarine waters shall be considered to extend from a bay or the open ocean to a point upstream where there is no significant mixing of fresh water and seawater. Estuarine waters included, but are not limited to, the Sacramento-San Joaquin Delta, as defined in Water Code section 12220, Suisun Bay, Carquinez Strait downstream to the Carquinez Bridge, and appropriate areas of the Smith, Mad, Eel, Noyo, Russian, Klamath, San Diego, and Otay rivers. Estuaries do not include inland surface waters or ocean waters.

Harmonic Mean

Harmonic mean flows are expressed as $Q_{hm} = (n)/(\sum_{i=1}^n 1/x_i)$

where x_i = specific data values and n = number of data values.

Inland Surface Waters

All surface waters of the state that do not include the ocean, enclosed bays, or estuaries.

Instantaneous Maximum Effluent Limitation

The highest allowable value for any single grab sample or aliquot (i.e., each grab sample or aliquot is independently compared to the instantaneous maximum limitation).

Instantaneous Minimum Effluent Limitation

The lowest allowable value for any single grab sample or aliquot (i.e., each grab sample or aliquot is independently compared to the instantaneous minimum limitation).

Instream Waste Concentration (IWC)

The concentration of effluent in the receiving water after mixing.

Maximum Daily Effluent Limitation (MDEL)

The highest allowable daily discharge of a pollutant, over a calendar day (or 24-hour period). For pollutants with limitations expressed in units of mass, the daily discharge is calculated as the total mass of the pollutant discharged over the day. For pollutants with limitations expressed in other units of measurement, the daily discharge is calculated as the arithmetic mean measurement of the pollutant over the day.

Median

The middle measurement in a set of data. The median of a set of data is found by first arranging the measurements in order of magnitude (either increasing or decreasing order). If the number of measurements (n) is odd, then the median = $X_{(n+1)/2}$. If n is even, then the median = $(X_{n/2} + X_{(n/2)+1})/2$ (i.e., the midpoint between the $n/2$ and $n/2+1$).

Method Detection Limit (MDL)

MDL is the minimum measured concentration of a substance that can be reported with 99 percent confidence that the measured concentration is distinguishable from method blank results, as defined in 40 C.F.R. Part 136, Attachment B.

Minimum Level (ML)

ML is the concentration at which the entire analytical system must give a recognizable signal and acceptable calibration point. The ML is the concentration in a sample that is equivalent to the concentration of the lowest calibration standard analyzed by a specific analytical procedure, assuming that all the method specified sample weights, volumes, and processing steps have been followed.

Mixing Zone

Mixing Zone is a limited volume of receiving water that is allocated for mixing with a wastewater discharge where water quality criteria can be exceeded without causing adverse effects to the overall water body.

Not Detected (ND)

Sample results which are less than the laboratory's MDL.

Null Hypothesis

A statement used in statistical testing that has been put forward either because it is believed to be true or because it is to be used as a basis for argument, but has not been proved.

Ocean Waters

The territorial marine waters of the State as defined by California law to the extent these waters are outside of enclosed bays, estuaries, and coastal lagoons. Discharges to ocean waters are regulated in accordance with the State Water Board’s California Ocean Plan.

Percent Effect

The percent effect at the instream waste concentration (IWC) shall be calculated using untransformed data and the following equation:

$$\text{Percent Effect of the Sample} = \frac{\text{Mean Control Response} - \text{Mean Sample Response}}{\text{Mean Control Response}} \cdot 100$$

Persistent Pollutants

Persistent pollutants are substances for which degradation or decomposition in the environment is nonexistent or very slow.

Pollutant Minimization Program (PMP)

PMP means waste minimization and pollution prevention actions that include, but are not limited to, product substitution, waste stream recycling, alternative waste management methods, and education of the public and businesses. The goal of the PMP shall be to reduce all potential sources of a priority pollutant(s) through pollutant minimization (control) strategies, including pollution prevention measures as appropriate, to maintain the effluent concentration at or below the water quality-based effluent limitation. Pollution prevention measures may be particularly appropriate for persistent bioaccumulative priority pollutants where there is evidence that beneficial uses are being impacted. The Central Valley Water Board may consider cost effectiveness when establishing the requirements of a PMP. The completion and implementation of a Pollution Prevention Plan, if required pursuant to Water Code section 13263.3(d), shall be considered to fulfill the PMP requirements.

Pollution Prevention

Pollution Prevention means any action that causes a net reduction in the use or generation of a hazardous substance or other pollutant that is discharged into water and includes, but is not limited to, input change, operational improvement, production process change, and product reformulation (as defined in Water Code section 13263.3). Pollution prevention does not include actions that merely shift a pollutant in wastewater from one environmental medium to another environmental medium, unless clear environmental benefits of such an approach are identified to the satisfaction of the State Water Resources Control Board (State Water Board) or Central Valley Water Board.

Regulatory Management Decision (RMD)

The decision that represents the maximum allowable error rates and thresholds for toxicity and non-toxicity that would result in an acceptable risk to aquatic life.

Response

A measured biological effect (e.g., survival, reproduction, growth) as a result of exposure to a stimulus.

Satellite Collection System

The portion, if any, of a sanitary sewer system owned or operated by a different public agency than the agency that owns and operates the wastewater treatment facility that a sanitary sewer system is tributary to.

Source of Drinking Water

Any water designated as municipal or domestic supply (MUN) in a Central Valley Water Board Basin Plan.

Species Sensitivity Screening

An analysis to determine the single most sensitive species from an array of test species to be used in a single species laboratory test series.

Standard Deviation (σ)

Standard Deviation is a measure of variability that is calculated as follows:

$$\sigma = (\sum [(x - \mu)^2] / (n - 1))^{0.5}$$

where:

x is the observed value;

μ is the arithmetic mean of the observed values; and

n is the number of samples.

Statewide Toxicity Provisions

The Statewide Toxicity Provisions became effective on 25 April 2022 and include statewide numeric water quality objectives for both acute and chronic toxicity and a program of implementation to control toxicity.

Test of Significant Toxicity (TST)

A statistical approach used to analyze aquatic toxicity test data, as described in *National Pollutant Discharge Elimination System Test of Significant Toxicity Implementation Document* (EPA 833-R-10-003, 2010), Appendix A, Figure A-1 and Table A-1 (Chronic Freshwater and East Coast Methods) and Appendix B, Table B-1.

Toxicity Reduction Evaluation (TRE)

TRE is a study conducted in a stepwise process designed to identify the causative agents of effluent or ambient toxicity, isolate the sources of toxicity, evaluate the effectiveness of toxicity control options, and then confirm the reduction in toxicity. The first steps of the TRE consist of the collection of data relevant to the toxicity, including additional toxicity testing, and an evaluation of facility operations and maintenance practices, and best management practices. A Toxicity Identification Evaluation (TIE) may be required as part of the TRE, if appropriate. (A TIE is a set of procedures to identify the specific chemical(s) responsible for toxicity. These

procedures are performed in three phases (characterization, identification, and confirmation) using aquatic organism toxicity tests.).

WET Maximum Daily Effluent Limitation (MDEL)

For the purposes of chronic and acute aquatic toxicity, an MDEL is an effluent limitation based on the outcome of the TST approach and the resulting percent effect at the IWC.

WET Median Monthly Effluent Limit (MMEL)

For the purposes of chronic and acute aquatic toxicity, an MMEL is an effluent limitation based on a maximum of three independent toxicity tests analyzed using the TST approach during a toxicity calendar month.

WET MMEL Compliance Tests

For the purposes of chronic and acute aquatic toxicity, a maximum of two tests that are used in addition to the routine monitoring test to determine compliance with the chronic and acute aquatic toxicity MMEL.

ATTACHMENT B – MAP

Figure B-1. Facility and Discharge Point Locations

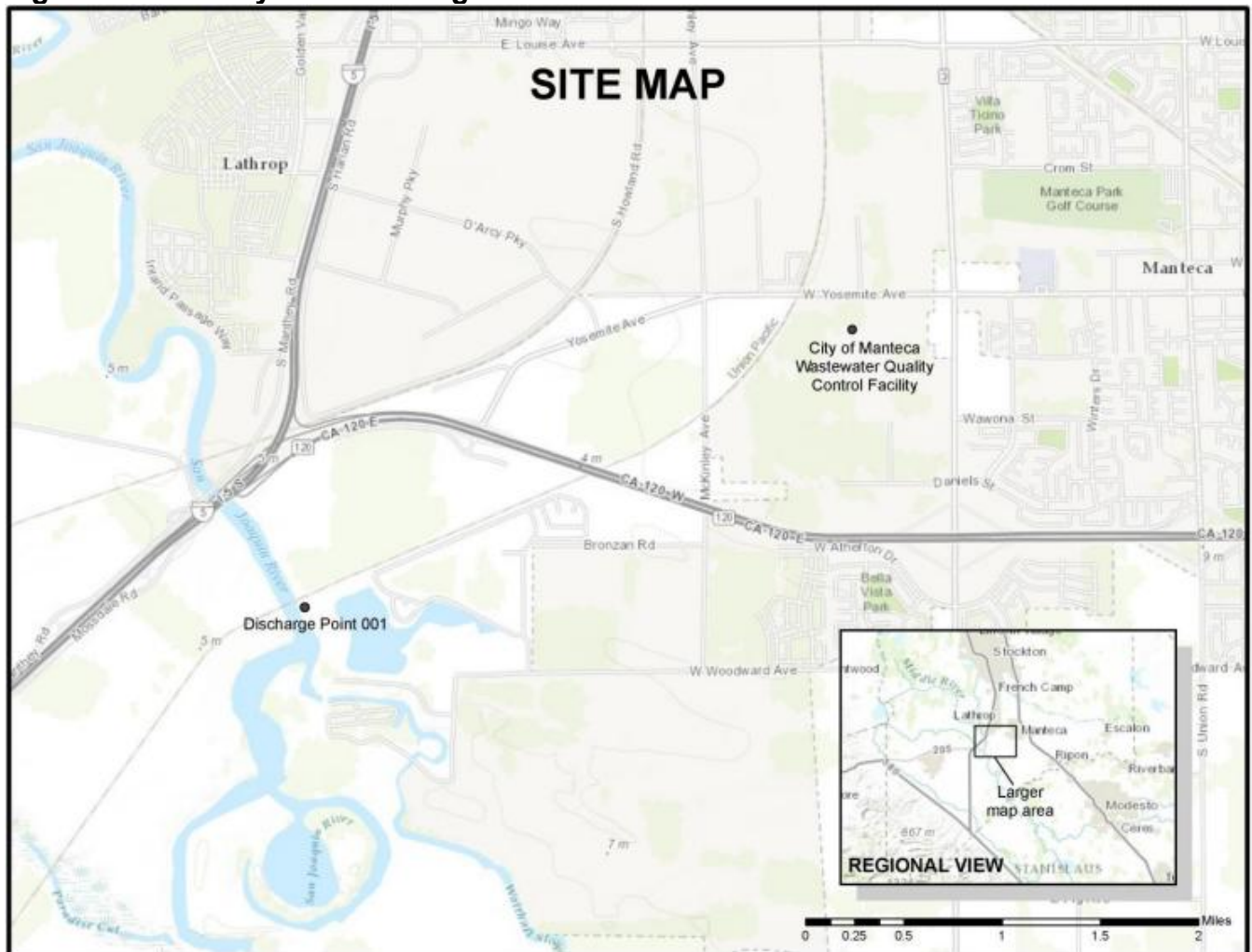
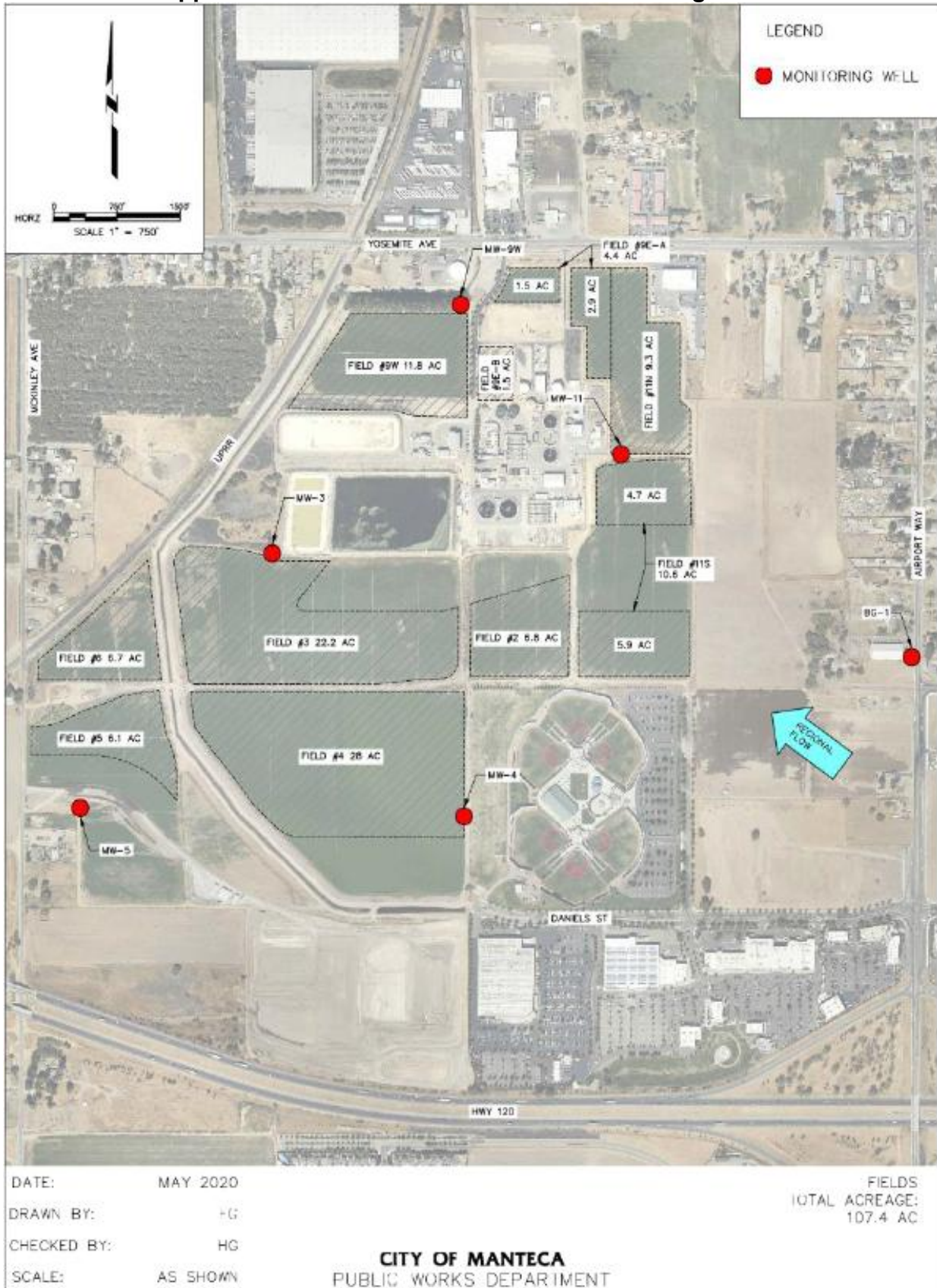
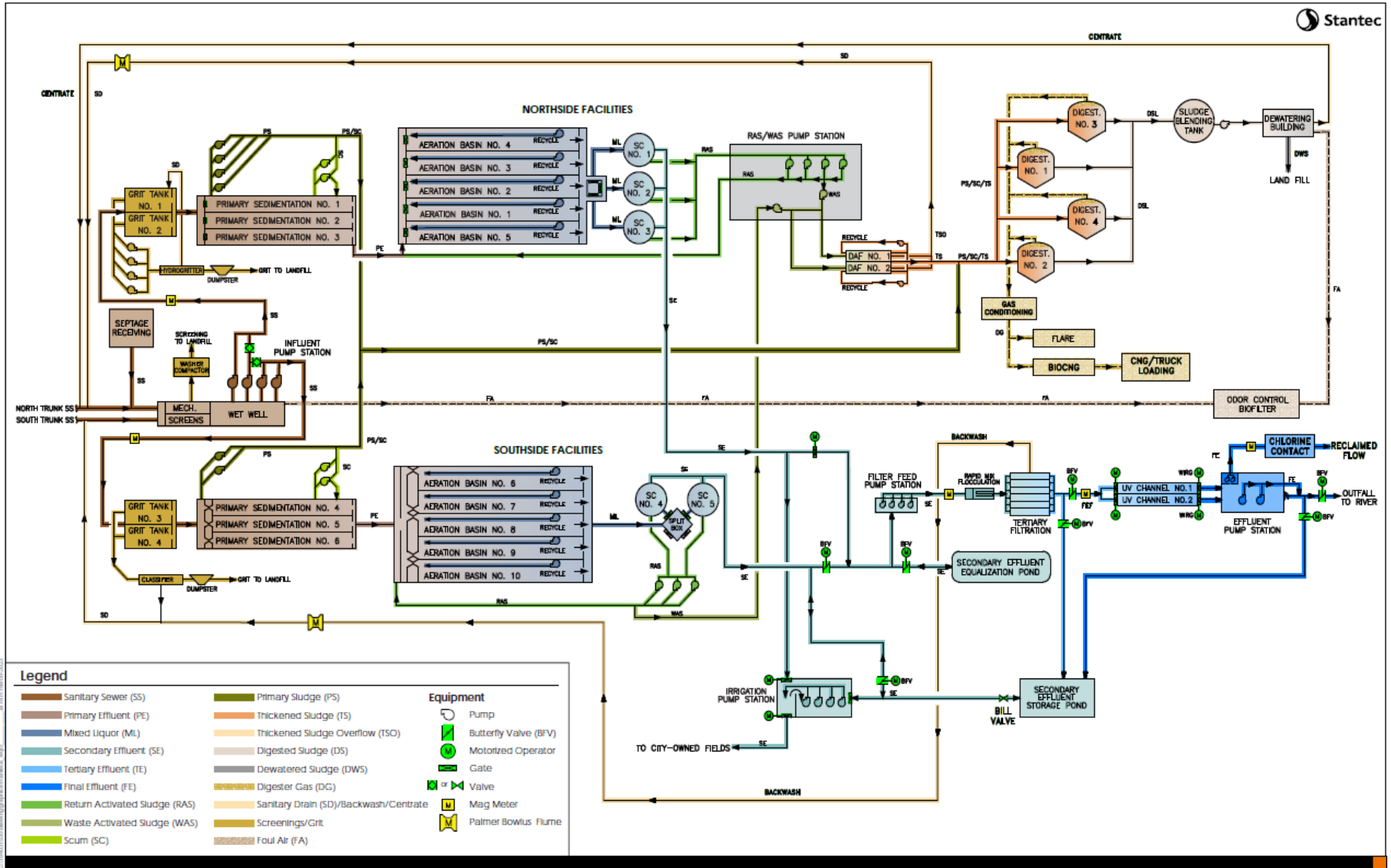

Figure B-3. Land Application Areas and Groundwater Monitoring Well Locations



ATTACHMENT C – FLOW SCHEMATIC



ATTACHMENT D – STANDARD PROVISIONS

I. STANDARD PROVISIONS – PERMIT COMPLIANCE

A. Duty to Comply:

1. The Discharger must comply with all of the terms, requirements, and conditions of this Order. Any noncompliance constitutes a violation of the Clean Water Act (CWA) and the California Water Code and is grounds for enforcement action; permit termination, revocation and reissuance, or modification; denial of a permit renewal application; or a combination thereof. (40 C.F.R. section 122.41(a); Wat. Code, sections 13261, 13263, 13265, 13268, 13000, 13001, 13304, 13350, 13385.)
2. The Discharger shall comply with effluent standards or prohibitions established under Section 307(a) of the CWA for toxic pollutants within the time provided in the regulations that establish these standards or prohibitions, even if this Order has not yet been modified to incorporate the requirement. (40 C.F.R. section 122.41(a)(1).)

B. Need to Halt or Reduce Activity Not a Defense

It shall not be a defense for a Discharger in an enforcement action that it would have been necessary to halt or reduce the permitted activity in order to maintain compliance with the conditions of this Order. (40 C.F.R. section 122.41(c).)

C. Duty to Mitigate

The Discharger shall take all reasonable steps to minimize or prevent any discharge in violation of this Order that has a reasonable likelihood of adversely affecting human health or the environment. (40 C.F.R. section 122.41(d).)

D. Proper Operation and Maintenance

The Discharger shall at all times properly operate and maintain all facilities and systems of treatment and control (and related appurtenances) which are installed or used by the Discharger to achieve compliance with the conditions of this Order. Proper operation and maintenance also includes having adequate laboratory controls and appropriate quality assurance procedures. This provision requires the operation of backup or auxiliary facilities or similar systems that are installed by a Discharger only when necessary to achieve compliance with the conditions of this Order. (40 C.F.R. section 122.41(e).)

E. Property Rights

1. This Order does not convey any property rights of any sort or any exclusive privileges. (40 C.F.R. section 122.41(g).)

2. The issuance of this Order does not authorize any injury to persons or property or invasion of other private rights, or any infringement of state or local law or regulations. (40 C.F.R. section 122.5(c).)

F. Inspection and Entry

The Discharger shall allow the Central Valley Water Board, State Water Board, U.S. EPA, and/or their authorized representatives (including an authorized contractor acting as their representative), upon the presentation of credentials and other documents, as may be required by law, to (33 U.S.C. section 1318(a)(4)(B); 40 C.F.R. section 122.41(i); Wat. Code, section 13267, 13383):

1. Enter upon the Discharger's premises where a regulated facility or activity is located or conducted, or where records are kept under the conditions of this Order (33 U.S.C section 1318(a)(4)(B)(ii); 40 C.F.R. section 122.41(i)(1); Wat. Code, sections 13267, 13383);
2. Have access to and copy, at reasonable times, any records that must be kept under the conditions of this Order (33 U.S.C. section 1318(a)(4)(B)(ii); 40 C.F.R. section 122.41(i)(2); Wat. Code, sections 13267, 13383);
3. Inspect and photograph, at reasonable times, any facilities, equipment (including monitoring and control equipment), practices, or operations regulated or required under this Order (33 U.S.C section 1318(a)(4)(B)(ii); 40 C.F.R. section 122.41(i)(3); Wat. Code, section 13267, 13383); and
4. Sample or monitor, at reasonable times, for the purposes of assuring Order compliance or as otherwise authorized by the CWA or the Water Code, any substances or parameters at any location. (33 U.S.C section 1318(a)(4)(B); 40 C.F.R. section 122.41(i)(4); Wat. Code, sections 13267, 13383.)

G. Bypass

1. Definitions
 - a. "Bypass" means the intentional diversion of waste streams from any portion of a treatment facility. (40 C.F.R. section 122.41(m)(1)(i).)
 - b. "Severe property damage" means substantial physical damage to property, damage to the treatment facilities, which causes them to become inoperable, or substantial and permanent loss of natural resources that can reasonably be expected to occur in the absence of a bypass. Severe property damage does not mean economic loss caused by delays in production. (40 C.F.R. section 122.41(m)(1)(ii).)
2. Bypass not exceeding limitations. The Discharger may allow any bypass to occur which does not cause exceedances of effluent limitations, but only if it is for essential maintenance to assure efficient operation. These bypasses are not

subject to the provisions listed in Standard Provisions – Permit Compliance I.G.3, I.G.4, and I.G.5 below. (40 C.F.R. section 122.41(m)(2).)

3. Prohibition of bypass. Bypass is prohibited, and the Central Valley Water Board may take enforcement action against a Discharger for bypass, unless (40 C.F.R. section 122.41(m)(4)(i)):
 - a. Bypass was unavoidable to prevent loss of life, personal injury, or severe property damage (40 C.F.R. section 122.41(m)(4)(i)(A));
 - b. There were no feasible alternatives to the bypass, such as the use of auxiliary treatment facilities, retention of untreated wastes, or maintenance during normal periods of equipment downtime. This condition is not satisfied if adequate back-up equipment should have been installed in the exercise of reasonable engineering judgment to prevent a bypass that occurred during normal periods of equipment downtime or preventive maintenance (40 C.F.R. section 122.41(m)(4)(i)(B)); and
 - c. The Discharger submitted notice to the Central Valley Water Board as required under Standard Provisions – Permit Compliance I.G.5 below. (40 C.F.R. section 122.41(m)(4)(i)(C).)
4. The Central Valley Water Board may approve an anticipated bypass, after considering its adverse effects, if the Central Valley Water Board determines that it will meet the three conditions listed in Standard Provisions – Permit Compliance I.G.3 above. (40 C.F.R. section 122.41(m)(4)(ii).)

5. Notice

- a. **Anticipated bypass.** If the Discharger knows in advance of the need for a bypass, it shall submit prior notice if possible, at least 10 days before the date of the bypass. The notice shall be sent to the Central Valley Water Board. As of 21 December 2023, all notices shall be submitted electronically to the initial recipient (State Water Board's [California Integrated Water Quality System \(CIWQS\) Program website](http://www.waterboards.ca.gov/water_issues/programs/ciwqs/) (http://www.waterboards.ca.gov/water_issues/programs/ciwqs/), defined in Standard Provisions – Reporting V.J below. Notices shall comply with 40 C.F.R. Part 3, section 122.22, and 40 C.F.R. Part 127. (40 C.F.R. section 122.41(m)(3)(i).)
- b. **Unanticipated bypass.** The Discharger shall submit a notice of an unanticipated bypass as required in Standard Provisions - Reporting V.E below (24-hour notice). The notice shall be sent to the Central Valley Water Board. As of 21 December 2023, all notices shall be submitted electronically to the initial recipient (State Water Board's [California Integrated Water Quality System \(CIWQS\) Program website](http://www.waterboards.ca.gov/water_issues/programs/ciwqs/). (http://www.waterboards.ca.gov/water_issues/programs/ciwqs/), defined in Standard Provisions – Reporting V.J below. Notices shall comply with 40

C.F.R. Part 3, section 122.22, and 40 C.F.R. Part 127. (40 C.F.R. section 122.41(m)(3)(ii).)

H. Upset

Upset means an exceptional incident in which there is unintentional and temporary noncompliance with technology-based permit effluent limitations because of factors beyond the reasonable control of the Discharger. An upset does not include noncompliance to the extent caused by operational error, improperly designed treatment facilities, inadequate treatment facilities, lack of preventive maintenance, or careless or improper operation. (40 C.F.R. section 122.41(n)(1).)

1. Effect of an upset. An upset constitutes an affirmative defense to an action brought for noncompliance with such technology-based permit effluent limitations if the requirements of Standard Provisions – Permit Compliance I.H.2 below are met. No determination made during administrative review of claims that noncompliance was caused by upset, and before an action for noncompliance, is final administrative action subject to judicial review. (40 C.F.R. section 122.41(n)(2).)
2. Conditions necessary for a demonstration of upset. A Discharger who wishes to establish the affirmative defense of upset shall demonstrate, through properly signed, contemporaneous operating logs or other relevant evidence that (40 C.F.R. section 122.41(n)(3)):
 - a. An upset occurred and that the Discharger can identify the cause(s) of the upset (40 C.F.R. section 122.41(n)(3)(i));
 - b. The permitted facility was, at the time, being properly operated (40 C.F.R. section 122.41(n)(3)(ii));
 - c. The Discharger submitted notice of the upset as required in Standard Provisions – Reporting V.E.2.b below (24-hour notice) (40 C.F.R. section 122.41(n)(3)(iii)); and
 - d. The Discharger complied with any remedial measures required under Standard Provisions – Permit Compliance I.C above. (40 C.F.R. section 122.41(n)(3)(iv).)
3. Burden of proof. In any enforcement proceeding, the Discharger seeking to establish the occurrence of an upset has the burden of proof. (40 C.F.R. section 122.41(n)(4).)

II. STANDARD PROVISIONS – PERMIT ACTION

A. General

This Order may be modified, revoked and reissued, or terminated for cause. The filing of a request by the Discharger for modification, revocation and reissuance, or termination, or a notification of planned changes or anticipated noncompliance does not stay any Order condition. (40 C.F.R. section 122.41(f).)

B. Duty to Reapply

If the Discharger wishes to continue an activity regulated by this Order after the expiration date of this Order, the Discharger must apply for and obtain a new permit. (40 C.F.R. section 122.41(b).)

C. Transfers

This Order is not transferable to any person except after notice to the Central Valley Water Board. The Central Valley Water Board may require modification or revocation and reissuance of the Order to change the name of the Discharger and incorporate such other requirements as may be necessary under the CWA and the Water Code. (40 C.F.R. section 122.41(l)(3); 122.61.)

III. STANDARD PROVISIONS – MONITORING

- A.** Samples and measurements taken for the purpose of monitoring shall be representative of the monitored activity. (40 C.F.R. section 122.41(j)(1).)
- B.** Monitoring must be conducted according to test procedures approved under 40 C.F.R. Part 136 for the analyses of pollutants unless another method is required under 40 C.F.R. subchapters N or O. Monitoring must be conducted according to sufficiently sensitive test methods approved under 40 C.F.R. Part 136 for the analysis of pollutants or pollutant parameters or as required under 40 C.F.R. chapter 1, subchapter N or O. For the purposes of this paragraph, a method is sufficiently sensitive when the method has the lowest ML of the analytical methods approved under 40 C.F.R. Part 136 or required under 40 C.F.R. chapter 1, subchapter N or O for the measured pollutant or pollutant parameter, or when:
1. The method minimum level (ML) is at or below the level of the most stringent effluent limitation established in the permit for the measured pollutant or pollutant parameter, and;
 - a. The method ML is at or below the level of the most stringent applicable water quality criterion for the measured pollutant or pollutant parameter, or;
 - b. The method ML is above the applicable water quality criterion but the amount of the pollutant or pollutant parameter in the facility's discharge is high enough that the method detects and quantifies the level of the pollutant or pollutant parameter in the discharge.

In the case of pollutants or pollutant parameters for which there are no approved methods under 40 C.F.R. Part 136 or otherwise required under 40 C.F.R. chapter 1, subchapters N or O, monitoring must be conducted according to a test procedure specified in this Order for such pollutants or pollutant parameters. (40 C.F.R. sections 122.21(e)(3), 122.41(j)(4); 122.44(i)(1)(iv).)

IV. STANDARD PROVISIONS – RECORDS

- A.** Except for records of monitoring information required by this Order related to the Discharger's sewage sludge use and disposal activities, which shall be retained for a period of at least five years (or longer as required by 40 C.F.R. part 503), the Discharger shall retain records of all monitoring information, including all calibration and maintenance records and all original strip chart recordings for continuous monitoring instrumentation, copies of all reports required by this Order, and records of all data used to complete the application for this Order, for a period of at least three (3) years from the date of the sample, measurement, report or application. This period may be extended by request of the Central Valley Water Board Executive Officer at any time. (40 C.F.R. section 122.41(j)(2).)
- B.** Records of monitoring information shall include:
1. The date, exact place, and time of sampling or measurements (40 C.F.R. section 122.41(j)(3)(i));
 2. The individual(s) who performed the sampling or measurements (40 C.F.R. section 122.41(j)(3)(ii));
 3. The date(s) analyses were performed (40 C.F.R. section 122.41(j)(3)(iii));
 4. The individual(s) who performed the analyses (40 C.F.R. section 122.41(j)(3)(iv));
 5. The analytical techniques or methods used (40 C.F.R. section 122.41(j)(3)(v));
and
 6. The results of such analyses. (40 C.F.R. section 122.41(j)(3)(vi).)
- C.** Claims of confidentiality for the following information will be denied (40 C.F.R. section 122.7(b)):
1. The name and address of any permit applicant or Discharger (40 C.F.R. section 122.7(b)(1)); and
 2. Permit applications and attachments, permits and effluent data. (40 C.F.R. section 122.7(b)(2).)

V. STANDARD PROVISIONS – REPORTING

A. Duty to Provide Information

The Discharger shall furnish to the Central Valley Water Board, State Water Board, or U.S. EPA within a reasonable time, any information which the Central Valley Water Board, State Water Board, or U.S. EPA may request to determine whether cause exists for modifying, revoking and reissuing, or terminating this Order or to determine compliance with this Order. Upon request, the Discharger shall also furnish to the Central Valley Water Board, State Water Board, or U.S. EPA copies of records required to be kept by this Order. (40 C.F.R. section 122.41(h); Wat. Code, sections 13267, 13383.)

B. Signatory and Certification Requirements

1. All applications, reports, or information submitted to the Central Valley Water Board, State Water Board, and/or U.S. EPA shall be signed and certified in accordance with Standard Provisions – Reporting V.B.2, V.B.3, V.B.4, V.B.5, and V.B.6 below. (40 C.F.R. section 122.41(k).)
2. All permit applications shall be signed by either a principal executive officer or ranking elected official. For purposes of this provision, a principal executive officer of a federal agency includes: (i) the chief executive officer of the agency, or (ii) a senior executive officer having responsibility for the overall operations of a principal geographic unit of the agency (e.g., Regional Administrators of U.S. EPA). (40 C.F.R. section 122.22(a)(3).)
3. All reports required by this Order and other information requested by the Central Valley Water Board, State Water Board, or U.S. EPA shall be signed by a person described in Standard Provisions – Reporting V.B.2 above, or by a duly authorized representative of that person. A person is a duly authorized representative only if:
 - a. The authorization is made in writing by a person described in Standard Provisions – Reporting V.B.2 above (40 C.F.R. section 122.22(b)(1));
 - b. The authorization specifies either an individual or a position having responsibility for the overall operation of the regulated facility or activity such as the position of plant manager, operator of a well or a well field, superintendent, position of equivalent responsibility, or an individual or position having overall responsibility for environmental matters for the company. (A duly authorized representative may thus be either a named individual or any individual occupying a named position.) (40 C.F.R. section 122.22(b)(2)); and
 - c. The written authorization is submitted to the Central Valley Water Board and State Water Board. (40 C.F.R. section 122.22(b)(3).)
4. If an authorization under Standard Provisions – Reporting V.B.3 above is no longer accurate because a different individual or position has responsibility for the overall operation of the facility, a new authorization satisfying the requirements of Standard Provisions – Reporting V.B.3 above must be submitted

to the Central Valley Water Board and State Water Board prior to or together with any reports, information, or applications, to be signed by an authorized representative. (40 C.F.R. section 122.22(c).)

5. Any person signing a document under Standard Provisions – Reporting V.B.2 or V.B.3 above shall make the following certification:

“I certify under penalty of law that this document and all attachments were prepared under my direction or supervision in accordance with a system designed to assure that qualified personnel properly gather and evaluate the information submitted. Based on my inquiry of the person or persons who manage the system or those persons directly responsible for gathering the information, the information submitted is, to the best of my knowledge and belief, true, accurate, and complete. I am aware that there are significant penalties for submitting false information, including the possibility of fine and imprisonment for knowing violations.” (40 C.F.R. section 122.22(d).)
6. Any person providing the electronic signature for such documents described in Standard Provision – V.B.1, V.B.2, or V.B.3 that are submitted electronically shall meet all relevant requirements of Standard Provisions – Reporting V.B, and shall ensure that all of the relevant requirements of 40 C.F.R. part 3 (Cross-Media Electronic Reporting) and 40 C.F.R. part 127 (NPDES Electronic Reporting Requirements) are met for that submission. (40 C.F.R section 122.22(e).)

C. Monitoring Reports

1. Monitoring results shall be reported at the intervals specified in the Monitoring and Reporting Program (Attachment E) in this Order. (40 C.F.R. section 122.41(l)(4).)
2. Monitoring results must be reported on a Discharge Monitoring Report (DMR) form or forms provided or specified by the Central Valley Water Board or State Water Board for reporting the results of monitoring, sludge use, or disposal practices. As of 21 December 2016, all reports and forms must be submitted electronically to the initial recipient, defined in Standard Provisions – Reporting V.J, and comply with 40 C.F.R. part 3, section 122.22, and 40 C.F.R. part 127. (40 C.F.R. section 122.41(l)(4)(i).)
3. If the Discharger monitors any pollutant more frequently than required by this Order using test procedures approved under 40 C.F.R. part 136, or another method required for an industry-specific waste stream under 40 C.F.R. subchapters N or O, the results of such monitoring shall be included in the calculation and reporting of the data submitted in the DMR or sludge reporting form specified by the Central Valley Water Board. (40 C.F.R. section 122.41(l)(4)(ii).)

4. Calculations for all limitations, which require averaging of measurements, shall utilize an arithmetic mean unless otherwise specified in this Order. (40 C.F.R. section 122.41(l)(4)(iii).)

D. Compliance Schedules

Reports of compliance or noncompliance with, or any progress reports on, interim and final requirements contained in any compliance schedule of this Order, shall be submitted no later than 14 days following each schedule date. (40 C.F.R. section 122.41(l)(5).)

E. Twenty-Four Hour Reporting

1. The Discharger shall report any noncompliance which may endanger health or the environment. Any information shall be provided orally within 24 hours from the time the Discharger becomes aware of the circumstances. A report shall also be provided within five (5) days of the time the Discharger becomes aware of the circumstances. The report shall contain a description of the noncompliance and its cause; the period of noncompliance, including exact dates and times, and if the noncompliance has not been corrected, the anticipated time it is expected to continue; and steps taken or planned to reduce, eliminate, and prevent reoccurrence of the noncompliance.

For noncompliance events related to combined sewer overflows, sanitary sewer overflows, or bypass events, these reports must include the data described above (with the exception of time of discovery) as well as the type of event (combined sewer overflows, sanitary sewer overflows, or bypass events), type of sewer overflow structure (e.g., manhole, combined sewer overflow outfall), discharge volumes untreated by the treatment works treating domestic sewage, types of human health and environmental impacts of the sewer overflow event, and whether the noncompliance was related to wet weather.

As of 21 December 2020 all reports related to combined sewer overflows, sanitary sewer overflows, or bypass events must be submitted electronically to the initial recipient (State Water Board) defined in Standard Provisions – Reporting V.J. The reports shall comply with 40 C.F.R. part 3. They may also require the Discharger to electronically submit reports not related to combined sewer overflows, sanitary sewer overflows, or bypass events under this section. (40 C.F.R. section 122.41(l)(6)(i).)

F. Planned Changes

The Discharger shall give notice to the Central Valley Water Board as soon as possible of any planned physical alterations or additions to the permitted facility. Notice is required under this provision only when (40 C.F.R. section 122.41(l)(1)):

1. The alteration or addition to a permitted facility may meet one of the criteria for determining whether a facility is a new source in section 122.29(b) (40 C.F.R. section 122.41(l)(1)(i)); or
2. The alteration or addition could significantly change the nature or increase the quantity of pollutants discharged. This notification applies to pollutants that are not subject to effluent limitations in this Order. (40 C.F.R. section 122.41(l)(1)(ii).)
3. The alteration or addition results in a significant change in the Discharger's sludge use or disposal practices, and such alteration, addition, or change may justify the application of permit conditions that are different from or absent in the existing permit, including notification of additional use or disposal sites not reported during the permit application process or not reported pursuant to an approved land application plan. (40 C.F.R. section 122.41(l)(1)(iii).)

G. Anticipated Noncompliance

The Discharger shall give advance notice to the Central Valley Water Board of any planned changes in the permitted facility or activity that may result in noncompliance with this Order's requirements. (40 C.F.R. section 122.41(l)(2).)

H. Other Noncompliance

The Discharger shall report all instances of noncompliance not reported under Standard Provisions – Reporting V.C, V.D, and V.E above at the time monitoring reports are submitted. The reports shall contain the information listed in Standard Provision – Reporting V.E above. For noncompliance events related to combined sewer overflows, sanitary sewer overflows, or bypass events, these reports shall contain the information described in Standard Provision – Reporting V.E and the applicable required data in appendix A to 40 C.F.R. part 127. The Central Valley Water Board may also require the Discharger to electronically submit reports not related to combined sewer overflows, sanitary sewer overflows, or bypass events under this section. (40 C.F.R. section 122.41(l)(7).)

I. Other Information

When the Discharger becomes aware that it failed to submit any relevant facts in a permit application, or submitted incorrect information in a permit application or in any report to the Central Valley Water Board, State Water Board, or U.S. EPA, the Discharger shall promptly submit such facts or information. (40 C.F.R. section 122.41(l)(8).)

J. Initial Recipient for Electronic Reporting Data

The owner, operator, or the duly authorized representative is required to electronically submit NPDES information specified in appendix A to 40 C.F.R. part 127 to the appropriate initial recipient, as determined by U.S. EPA, and as defined in 40 C.F.R. section 127.2(b). U.S. EPA will identify and publish the list of initial

recipients on its website and in the Federal Register, by state and by NPDES data group [see 40 C.F.R. section 127.2(c)]. U.S. EPA will update and maintain this listing. (40 C.F.R. section 122.41(l)(9).)

VI. STANDARD PROVISIONS – ENFORCEMENT

- A.** The Central Valley Water Board is authorized to enforce the terms of this permit under several provisions of the Water Code, including, but not limited to, sections 13350, 13385, 13386, and 13387.

VII. ADDITIONAL PROVISIONS – NOTIFICATION LEVELS

A. Publicly-Owned Treatment Works (POTWs)

All POTWs shall provide adequate notice to the Central Valley Water Board of the following (40 C.F.R. section 122.42(b)):

1. Any new introduction of pollutants into the POTW from an indirect discharger that would be subject to sections 301 or 306 of the CWA if it were directly discharging those pollutants (40 C.F.R. section 122.42(b)(1)); and
2. Any substantial change in the volume or character of pollutants being introduced into that POTW by a source introducing pollutants into the POTW at the time of adoption of the Order. (40 C.F.R. section 122.42(b)(2).)
3. Adequate notice shall include information on the quality and quantity of effluent introduced into the POTW as well as any anticipated impact of the change on the quantity or quality of effluent to be discharged from the POTW. (40 C.F.R. section 122.42(b)(3).)

ATTACHMENT E – MONITORING AND REPORTING PROGRAM

Table of Contents

I. General Monitoring Provisions..... E-2

II. Monitoring Locations E-3

III. Influent Monitoring Requirements..... E-5

 A. Monitoring Location INF-001..... E-5

IV. Effluent Monitoring Requirements E-6

 A. Monitoring Location EFF-001..... E-6

V. Whole Effluent Toxicity Testing Requirements E-8

VI. Land Discharge Monitoring Requirements E-13

 A. Monitoring Location LND-001 E-13

VII. Recycling Monitoring Requirements E-16

 A. Monitoring Location REC-001 E-16

VIII. Receiving Water Monitoring Requirements E-16

 A. Monitoring Locations RSW-001 and RSW-002..... E-17

 B. Monitoring Locations MW-3, MW-4, MW-5, MW-9W, MW-11, and MW-AW..... E-18

IX. Other Monitoring Requirements..... E-19

 A. Biosolids E-19

 B. Filtration System and Ultraviolet Light (UV) Disinfection System..... E-20

 C. Treatment Pond Monitoring E-21

 D. Pyrethroid Pesticides Monitoring. E-21

 E. Effluent and Receiving Water Characterization E-21

X. Reporting Requirements..... E-28

 A. General Monitoring and Reporting Requirements..... E-28

 B. Self-Monitoring Reports (SMRs)..... E-29

 C. Discharge Monitoring Reports (DMRs)..... E-33

 D. Other Reports E-33

Tables

Table E-1. Monitoring Station Locations E-3

Table E-2. Influent Monitoring..... E-5

Table E-3. Effluent Monitoring E-6

Table E-4. Land Discharge Monitoring Requirements E-13

Table E-5. Land Application Area Monitoring Requirements E-14

Table E-6. Recycled Water Monitoring Requirements..... E-16

Table E-7. Receiving Water Monitoring Requirements E-17

Table E-8. Groundwater Monitoring Requirements E-18

Table E-9. Filtration System and UV Disinfection System Monitoring Requirements E-20

Table E-10. Pond Monitoring Requirements..... E-21

Table E-11. Effluent and Receiving Water Characterization Monitoring E-23

Table E-12. Monitoring Periods and Reporting Schedule E-30

Table E-13. Technical Reports E-43

ATTACHMENT E – MONITORING AND REPORTING PROGRAM (MRP)

The Code of Federal Regulations (40 C.F.R. section 122.48) requires that all NPDES permits specify monitoring and reporting requirements. Water Code sections 13267 and 13383 authorize the Central Valley Water Board to establish monitoring, inspection, entry, reporting, and recordkeeping requirements. This MRP establishes monitoring and reporting requirements that implement federal and California requirements.

I. GENERAL MONITORING PROVISIONS

- A. Samples and measurements taken as required herein shall be representative of the volume and nature of the monitored discharge. All samples shall be taken at the monitoring locations specified below and, unless otherwise specified, before the monitored flow joins or is diluted by any other waste stream, body of water, or substance. Monitoring locations shall not be changed without notification to and the approval of the Central Valley Water Board.
- B. Final effluent samples shall be taken downstream of the last addition of wastes to the treatment or discharge works where a representative sample may be obtained prior to mixing with the receiving waters. Samples shall be collected at such a point and in such a manner to ensure a representative sample of the discharge.
- C. Chemical, bacteriological, and bioassay analyses of any material required by this Order shall be conducted by a laboratory accredited for such analyses by the State Water Resources Control Board (State Water Board), Division of Drinking Water (DDW; formerly the Department of Public Health), in accordance with the provision of Water Code section 13176. Laboratories that perform sample analyses must be identified in all monitoring reports submitted to the Central Valley Water Board. In the event an accredited laboratory is not available to the Discharger for any onsite field measurements such as pH, dissolved oxygen (DO), turbidity, temperature, and residual chlorine, such analyses performed by a non-accredited laboratory will be accepted provided a Quality Assurance-Quality Control Program is instituted by the laboratory. A manual containing the steps followed in this program for any onsite field measurements such as pH, DO, turbidity, temperature, and residual chlorine must be kept onsite in the treatment facility laboratory and shall be available for inspection by Central Valley Water Board staff. The Discharger must demonstrate sufficient capability (qualified and trained employees, properly calibrated and maintained field instruments, etc.) to adequately perform these field measurements. The Quality Assurance-Quality Control Program must conform to U.S. EPA guidelines or to procedures approved by the Central Valley Water Board.
- D. Appropriate flow measurement devices and methods consistent with accepted scientific practices shall be selected and used to ensure the accuracy and reliability of measurements of the volume of monitored discharges. All monitoring instruments and devices used by the Discharger to fulfill the prescribed monitoring program shall be properly maintained and calibrated as necessary, at least yearly, to ensure their continued accuracy. All flow measurement devices shall be calibrated at least once per year to ensure continued accuracy of the devices.

- E. Monitoring results, including noncompliance, shall be reported at intervals and in a manner specified in this Monitoring and Reporting Program.
- F. Laboratory analytical methods shall be sufficiently sensitive in accordance with the Sufficiently Sensitive Methods Rule (SSM Rule) specified under 40 C.F.R. 122.21(e)(3) and 122.44(i)(1)(iv). A U.S. EPA-approved analytical method is sufficiently sensitive for a pollutant/parameter where:
 1. The method minimum level (ML) is at or below the applicable water quality objective for the receiving water, or;
 2. The method ML is above the applicable water quality objective for the receiving water but the amount of the pollutant/parameter in the discharge is high enough that the method detects and quantifies the level of the pollutant/parameter, or;
 3. the method ML is above the applicable water quality objective for the receiving water, but the ML is the lowest of the 40 C.F.R. 136 U.S. EPA-approved analytical methods for the pollutant/parameter.
- G. The Discharger shall ensure that the results of the Discharge Monitoring Report-Quality Assurance (DMR-QA) Study or the most recent Water Pollution Performance Evaluation Study are submitted annually to the State Water Resources Control Board at the following address or electronically via email to the DMR-QA Coordinator:

State Water Resources Control Board
 Quality Assurance Program Officer
 Office of Information Management and Analysis
 1001 I Street, Sacramento, CA 95814
- H. The Discharger shall file with the Central Valley Water Board technical reports on self-monitoring performed according to the detailed specifications contained in this Monitoring and Reporting Program.

II. MONITORING LOCATIONS

The Discharger shall establish the following monitoring locations to demonstrate compliance with the effluent limitations, discharge specifications, and other requirements in this Order:

Table E-1. Monitoring Station Locations

Discharge Point Name	Monitoring Location Name	Monitoring Location Description
--	INF-001	A location where a representative sample of the Facility influent can be obtained, prior to any additives, treatment processes, and plant return flows.

Discharge Point Name	Monitoring Location Name	Monitoring Location Description
001	EFF-001	A location where a representative sample of the Facility effluent can be obtained prior to discharge to the receiving water. Latitude: 37° 46' 45" N, Longitude: 121° 18' 0" W
--	LND-001	At the irrigation distribution box, where all waste tributary to the irrigation line is present, representative of the irrigation reuse waters applied to the agricultural fields.
--	REC-001	Location at the tertiary effluent station where a representative sample of the Facility recycled water can be obtained prior to distribution to the Discharger's customers.
--	RSW-001	In the San Joaquin River, mid-stream approximately 100 feet south of Discharge Point 001. Latitude: 37° 46' 45" N, Longitude: 121° 18' 2" W
--	RSW-002	In the San Joaquin River, mid-stream approximately 500 feet north of Discharge Point 001. Latitude: 37° 46' 50" N, Longitude: 121° 18' 6" W
--	MW-3	Compliance groundwater monitoring well located in land application agricultural Field 3.
--	MW-4	Compliance groundwater monitoring well located in land application agricultural Field 4.
--	MW-5	Compliance groundwater monitoring well located in land application agricultural Field 5.
--	MW-9W	Compliance groundwater monitoring well located in land application agricultural Field 9W.
--	MW-11	Compliance groundwater monitoring well located in land application agricultural Field 11.
--	MW-AW	Background groundwater monitoring well located on Airport Way, upgradient and approximately 1,200 feet east of the agricultural fields.
--	BIO-001	A location where a representative sample of the biosolids can be obtained prior to removal from the Facility.
--	FIL-001	Monitoring of the filter effluent to be measured immediately downstream of the filters prior to the ultraviolet light (UV) disinfection system.
--	UVS-001	A location where a representative sample of wastewater can be collected immediately downstream of the UV disinfection system.
--	PND-001	At a point in the Secondary Effluent Storage Pond at which all waste tributary to the pond is present, and is representative of the wastewaters discharged into the pond.

Discharge Point Name	Monitoring Location Name	Monitoring Location Description
--	PND-002	At a point in the Food Processing Pond at which all waste tributary to the pond is present, and is representative of the wastewaters discharged into the pond.
--	PND-003	At a point in the Secondary Effluent Equalization Pond at which all waste tributary to the pond is present, and is representative of the wastewaters discharged into the pond.

Table E-1 Note:

1. The North latitude and West longitude information in Table E-1 are approximate for administrative purposes.

III. INFLUENT MONITORING REQUIREMENTS

A. Monitoring Location INF-001

1. The Discharger shall monitor influent to the Facility at Monitoring Location INF-001 in accordance with Table E-2 and the testing requirements described in section III.A.2 below:

Table E-2. Influent Monitoring

Parameter	Units	Sample Type	Minimum Sampling Frequency
Flow	MGD	Meter	Continuous
Biochemical Oxygen Demand, 5-day @ 20°Celsius (BOD ₅)	mg/L	24-hour Composite	1/Week
Electrical Conductivity @ 25°C	µmhos/cm	Grab	1/Month
Total Suspended Solids	mg/L	24-hour Composite	1/Week

2. **Table E-2 Testing Requirements.** The Discharger shall comply with the following testing requirements when monitoring for the parameters described in Table E-2:
 - a. **Applicable to all parameters.** Parameters shall be analyzed using the analytical methods described in 40 CFR part 136; or by methods approved by the Central Valley Water Board or the State Water Board. In addition, if requested by the Discharger, the sample type may be modified by the Executive Officer to another 40 CFR part 136 allowed sample type.
 - b. **Grab Samples.** All grab samples shall not be collected at the same time each day to get a complete representation of variations in the influent.

- c. **24-Hour Composite Samples.** All composite samples shall be collected from a 24-hour flow proportional composite.

IV. EFFLUENT MONITORING REQUIREMENTS

A. Monitoring Location EFF-001

1. The Discharger shall monitor tertiary treated effluent at Monitoring Location EFF-001 in accordance with Table E-3 and the testing requirements described in section IV.A.2 below:

Table E-3. Effluent Monitoring

Parameter	Units	Sample Type	Minimum Sampling Frequency
Flow	MGD	Meter	Continuous
Ammonia Nitrogen, Total (as N)	mg/L	Grab	1/Week
Ammonia Nitrogen, Total (as N)	lbs/day	Calculate	1/Week
Biochemical Oxygen Demand, 5-day @ 20° Celcius (BOD ₅)	mg/L	24-hour Composite	3/Week
BOD ₅	% removal	Calculate	1/Month
Chlorpyrifos	µg/L	Grab	1/Year
Diazinon	µg/L	Grab	1/Year
Dieldrin	ng/L	24-hour Composite	1/Quarter
Dissolved Organic Carbon	mg/L	Grab	1/Quarter
Dissolved Oxygen	mg/L	Grab	2/Month
Electrical Conductivity @ 25° Celcius	µmhos/cm	Grab	1/Month
Hardness, Total (as CaCO ₃)	mg/L	Grab	1/Month
Mercury, Total	µg/L	Grab	1/Quarter
Mercury, Total	grams/year	Calculate	1/Year
Methylmercury	µg/L	Grab	1/Quarter
Methylmercury	grams/year	Calculate	1/Year
Nitrate Plus Nitrite Nitrogen, Total (as N)	mg/L	Grab	1/Month
pH	standard units	Grab	1/Day
Temperature	°F	Grab	1/Week
Total Dissolved Solids	mg/L	Grab	1/Quarter
Total Suspended Solids (TSS)	mg/L	24-hour Composite	3/Week
TSS	% removal	Calculate	1/Month

2. **Table E-3 Testing Requirements.** The Discharger shall comply with the following testing requirements when monitoring for the parameters described in Table E-3:
- a. **Applicable to all parameters.** Parameters shall be analyzed using the analytical methods described in 40 CFR part 136 or by methods approved by the Central Valley Water Board or the State Water Board. In addition, if requested by the Discharger, the sample type may be modified by the Executive Officer to another 40 CFR part 136 allowed sample type.
 - b. **24-hour composite samples** shall be collected from a 24-hour flow proportional composite.
 - c. **Handheld Field Meter.** A handheld field meter may be used for **dissolved oxygen, electrical conductivity, temperature and pH**, provided the meter utilizes a U.S. EPA-approved algorithm/method and is calibrated and maintained in accordance with the manufacturer's instructions. A calibration and maintenance log for each meter used for monitoring required by this Monitoring and Reporting Program shall be maintained at the Facility.
 - d. **Temperature and pH** shall be recorded at the time of **ammonia** sample collection.
 - e. **Total Mercury and Methylmercury.** Unfiltered methylmercury and total mercury samples shall be taken using **clean hands/dirty hands procedures**, as described in U.S. EPA method 1669: Sampling Ambient Water for Trace Metals at U.S. EPA Water Quality Criteria Levels, for collection of equipment blanks (section 9.4.4.2). The analysis of methylmercury and total mercury shall be by U.S. EPA method 1630 and 1631 (Revision E), respectively, with a **reporting limit of 0.05 ng/L for methylmercury and 0.5 ng/L for total mercury.**
 - f. **Priority Pollutants.** For all priority pollutant constituents listed in Table E-3 (Bis (2-ethylhexyl) phthalate, Persistent Chlorinated Hydrocarbon Pesticides and Priority Pollutants and Other Constituents of Concern) the RL shall be consistent with sections 2.4.2 and 2.4.3 of the Policy for Implementation of Toxics Standards for Inland Surface Waters, Enclosed Bays, and Estuaries of California (State Implementation Policy or SIP) and the SSM Rule specified under 40 C.F.R. sections 122.21(e)(3) and 122.44(i)(1)(iv).
 - g. **Chlorpyrifos and Diazinon** shall be sampled using U.S. EPA Method 625M, Method 8141, or equivalent GC/MS method with a lower Reporting Limit than the Basin Plan Water Quality Objectives of 0.015 µg/L and 0.1 µg/L for chlorpyrifos and diazinon, respectively.

- h. **Dissolved Organic Carbon monitoring** shall be conducted concurrently with pH and hardness sampling.
- i. **Dieldrin.** Once per quarter monitoring for dieldrin is required for 12 months after which the monitoring frequency may be reduced to once per year if all samples were either non-detect (ND) or less than the CTR human health criteria of 0.014 ng/L. If a sample(s) is detected above the criteria in the 12 month period, quarterly monitoring shall continue for the duration of this Order.

V. WHOLE EFFLUENT TOXICITY TESTING REQUIREMENTS

A. Toxicity Calendar Month, Quarter and Year.

- 1. **Toxicity Calendar Month.** The toxicity calendar month is defined as the period of time beginning on the day of the initiation of the routine toxicity monitoring to the day before the corresponding day of the next month if the corresponding day exists, or if not to the last day of the next month.
- 2. **Toxicity Calendar Quarter.** A toxicity calendar quarter is defined as **three consecutive toxicity calendar months**. For purposes of this Order, the toxicity calendar quarters **begin on 1 January, 1 April, 1 July, and 1 October** (i.e., from 1 January to 31 March, from 1 April to 30 June, from 1 July to 30 September, etc.).
- 3. **Toxicity Calendar Year.** A toxicity calendar year is defined as **twelve consecutive toxicity calendar months**. For purposes of this Order, the toxicity calendar year **begins on 1 January** (i.e., 1 January to 31 December), in years in which there are at least 15 days of discharge in at least one toxicity calendar quarter.

B. Chronic Toxicity Testing.

The Discharger shall meet the following chronic toxicity testing requirements:

- 1. **Instream Waste Concentration (IWC) for Chronic Toxicity.** The chronic toxicity IWC is 100 percent effluent.
- 2. **Routine Monitoring Frequency.** The Discharger shall perform routine chronic toxicity testing once per toxicity calendar month in months in which there are at least 15 days of discharge, concurrent with effluent ammonia sampling. While the Discharger is conducting a Toxicity Reduction Evaluation the routine monitoring may be reduced to two (2) tests per calendar year. When there is no effluent available to complete a routine monitoring test or **MMEL** test, the test shall not be required, and subsequent routine monitoring continues at the frequency specified in the permit.
- 3. **Chronic Toxicity MMEL Compliance Testing.** If a routine chronic toxicity monitoring test results in a “fail” at the IWC, then the Discharger shall complete a chronic toxicity MMEL compliance test. If the MMEL compliance test results in a

“pass”, the Discharger shall complete a second chronic toxicity MMEL compliance test. All required chronic toxicity MMEL compliance tests shall be initiated within the same toxicity calendar month as the initiation of the routine monitoring chronic toxicity test. If the first chronic toxicity MMEL compliance test results in a “fail” at the IWC, then the second chronic toxicity MMEL compliance test is unnecessary and is waived.

4. **Sample Volumes.** Adequate sample volumes shall be collected to provide renewal water to complete the test in the event that the discharge is intermittent.
5. **Test Species.** The testing shall be conducted using the most sensitive species, which is water flea (*Ceriodaphnia dubia*). The Discharger shall conduct chronic toxicity tests with *Ceriodaphnia dubia*, unless otherwise specified in writing by the Executive Officer (see Section V.F.2 for more information on the determination of the most sensitive species).
6. **Test Methods.** Discharger shall conduct the chronic toxicity tests on effluent samples at the instream waste concentration for the discharge in accordance with species and test methods in Short-term Methods for Estimating the Chronic Toxicity of Effluents and Receiving Waters to Freshwater Organisms (EPA/821/R02/013, 2002; Table IA, 40 C.F.R. part 136).
7. **Dilution and Control Water.** Dilution water and control water shall be prepared and used as specified in the test methods manual. If dilution water and control water is different from test organism culture water, then a second control using culture water shall also be used.
8. **Test Failure.** If the effluent chronic toxicity test does not meet all test acceptability criteria (TAC) specified in the referenced test method in EPA/821-R-02-013, the Discharger must conduct a Replacement Test as soon as possible, as specified in subsection B.9, below.
9. **Replacement Test.** When a required toxicity test for routine monitoring or MMEL compliance tests is not completed, a new toxicity test to replace the toxicity test that was not completed shall be initiated as soon as possible. The new toxicity test shall replace the routine monitoring or MMEL compliance tests, as applicable, for the toxicity calendar month in which the toxicity test that was not completed was required to be initiated, even if the new toxicity test is initiated in a subsequent month. The new toxicity test for routine monitoring or MMEL compliance tests, as applicable, and any MMEL compliance tests required to be conducted due to the results of the new toxicity test shall be used to determine compliance with the effluent limitations for the toxicity calendar month in which the toxicity test that was not completed was required to be initiated. The new toxicity test and any MMEL compliance tests required to be conducted due to the results of the new toxicity test shall not be used to substitute for any other required toxicity tests.

Scenarios could occur in which a test is not initiated by a Discharger within the

required time period. When this is caused by circumstances outside of the Discharger's control, that were not preventable with the reasonable exercise of care, the Central Valley Water Board will not require the test to be initiated within the originally required time period, provided that the Discharger promptly initiates, and ultimately completes, a replacement test. In such cases, the Central Valley Water Board must determine that the circumstances were not preventable with the reasonable exercise of care.

C. Quality Assurance and Additional Requirements. Quality assurance measures, instructions, and other recommendations and requirements are found in the test methods manual previously referenced. Additional requirements are below.

1. The discharge is subject to determination of "Pass" or "Fail" from a chronic toxicity test using the Test of Significant Toxicity (TST) statistical t-test approach described in *National Pollutant Discharge Elimination System Test of Significant Toxicity Implementation Document* (EPA 833-R-10-003, 2010), Appendix A, Figure A-1 and Table A-1 (Chronic Freshwater and East Coast Methods) and Appendix B, Table B-1.

2. The null hypothesis (Ho) for the TST statistical approach is:

Mean discharge IWC response \leq RMD x Mean control response, where the chronic RMD = 0.75.

A test result that rejects this null hypothesis is reported as "Pass." A test result that does not reject this null hypothesis is reported as "Fail."

3. The relative "Percent Effect" at the discharge IWC is defined and reported as:

Percent Effect = ((Mean control response – Mean discharge IWC response) / Mean control response) x 100.

This is a t-test (formally Student's t-Test), a statistical analysis comparing two sets of replicate observations, i.e., a control and IWC. The purpose of this statistical test is to determine if the means of the two sets of observations are different (i.e., if the IWC differs from the control, the test result is "Fail"). The Welch's t-test employed by the TST statistical approach is an adaptation of Student's t-test and is used with two samples having unequal variances.

D. WET Testing Notification Requirements. The Discharger shall notify the Central Valley Water Board of test results exceeding the chronic toxicity effluent limitation as soon as the Discharger learns of the exceedance, but no later than 24-hours after receipt of the monitoring results.

E. WET Testing Reporting Requirements. The Discharger shall submit the full laboratory report for all toxicity testing as an attachment to CIWQS for the reporting period (e.g., monthly, quarterly, semi-annually or annually) and provide the data (i.e.,

Pass/Fail) in the PET tool for uploading into CIWQS. The laboratory report shall include:

1. The valid toxicity test results for the TST statistical approach, reported as “Pass” or “Fail” and “Percent Effect” at the IWC for the discharge, the dates of sample collection and initiation of each toxicity test all results for effluent parameters monitored concurrently by the lab conducting the toxicity test(s).
2. The statistical analysis used in *National Pollutant Discharge Elimination System Test of Significant Toxicity Implementation Document* (EPA 833-R-10-003, 2010) Appendix A, Figure A-1 and Table A-1, and Appendix B, Table B-1.
3. Statistical program (e.g., TST calculator, CETIS, etc.) output results, including graphical plots, for each toxicity test.

- F. Most Sensitive Species Screening.** The Discharger conducted its initial species sensitivity screening resulting in *Ceriodaphnia dubia* as the most sensitive species.

The species sensitivity screening shall be conducted at least once every fifteen years or if the effluent used in the last species sensitivity screening is no longer representative of the effluent and the results of the most recent species sensitivity screening shall be submitted with the Report of Waste Discharge.

1. **Frequency of Testing for Species Sensitivity Screening.** Species sensitivity screening for chronic toxicity shall include, at a minimum, chronic WET testing from four consecutive calendar quarters using the water flea (*Ceriodaphnia dubia*), fathead minnow (*Pimephales promelas*), and green algae (*Pseudokirchneriella subcapitata*, also known as *Selenastrum capricornutum*). The tests shall be performed at an IWC of no less than 100 percent effluent.
2. **Determination of Most Sensitive Species.** If a single test in the species sensitivity screening testing results in a “Fail” using the TST statistical approach, then the species used in that test shall be established as the most sensitive species. If there is more than a single test that results in a “Fail”, then of the species with results of a “Fail”, the species that exhibits the highest percent effect shall be established as the most sensitive species. If none of the tests in the species sensitivity screening results in a “Fail”, but at least one of the species exhibits a percent effect greater than **10** percent, then the single species that exhibits the highest percent effect shall be established as the most sensitive species. In all other circumstances, the Executive Officer shall have discretion to determine which single species is the most sensitive considering the test results from the species sensitivity screening. For subsequent species sensitivity screening, if the first two subsequent screening events result in no change in the most sensitive species, the Discharger may cease the subsequent species sensitive screening testing and the most sensitive species will remain unchanged.

The Executive Officer shall have discretion to allow the temporary use of the next appropriate species as the most sensitive species when the Discharger submits documentation and the Executive Officer determines that the Discharger has encountered unresolvable test interference or cannot secure a reliable supply of test organisms. The “next appropriate species” is a species in Table 1 of the Statewide Toxicity Provisions in the same test method classification (e.g., chronic aquatic toxicity test methods, acute aquatic toxicity test method), in the same salinity classification (e.g., freshwater or marine), and in the same taxon as the most sensitive species. When there are no other species in Table 1 in the same taxon as the most sensitive species (e.g., freshwater chronic toxicity tests), the “next appropriate species” is the species exhibiting the highest percent effect at the IWC tested in the species sensitivity screening other than the most sensitive species.

The most sensitive species shall be used for chronic toxicity testing for the remainder of the permit term. The Discharger may use the four most recent tests for use in determining the most sensitive species if the tests were conducted in a manner sufficient to make such determination. If the most sensitive species cannot be determined from the species sensitivity screening discussed above, the Discharger shall rotate the test species as the most sensitive species every toxicity calendar year as follows:

- a. *Ceriodaphnia dubia* (survival and reproduction test) for the remainder of the toxicity calendar year this Order is effective;
- b. *Pimephales promelas* (larval survival and growth test) for the entire toxicity calendar year following the toxicity calendar year this Order is effective;
- c. *Pseudokirchnerella subcapitata* (growth test) for the entire toxicity calendar year of the second year following the toxicity calendar year this Order is effective; and
- d. Cycling back to *Ceriodaphnia dubia* (survival and reproduction test) after *Pseudokirchnerella subcapitata* (growth test) and through the same rotation.

If a single test exhibits toxicity, demonstrated by a test that results in a “Fail” using the TST statistical approach, then the species used in that test shall be established as the most sensitive species until a subsequent Order rescinding this Order becomes effective.

G. Toxicity Reduction Evaluations (TRE)

1. **TRE Implementation.** The Discharger is required to conduct a TRE when there is any combination of two or more MDEL or MMEL violations within a single toxicity calendar month or within two successive toxicity calendar months. In addition, if other information indicates toxicity (e.g., results of additional monitoring, results of monitoring at a higher concentration than the IWC, fish kills, intermittent recurring toxicity), the Central Valley Water Board may require

a TRE. A TRE may also be required when there is no effluent available to complete a routine monitoring test or MMEL compliance test.

- a. **Preparation and Implementation of Detailed TRE Action Plan.** The Discharger shall conduct TREs in accordance with an approved TRE Work Plan. Within 30 days of the test result that triggered the TRE, the Discharger shall submit to the Executive Officer a TRE Action Plan. The TRE Action Plan shall include the following information, and comply with additional conditions set by the Executive Officer:
 - i. Specific actions the Discharger will take to investigate and identify the cause(s) of toxicity, including a TRE WET monitoring schedule;
 - ii. Specific actions the Discharger will take to mitigate the impact of the discharge and prevent the recurrence of toxicity; and
 - iii. A schedule for these actions, progress reports, and the final report.
- b. The Central Valley Water Board recognizes that toxicity may be episodic and identification of causes and reduction of sources of toxicity may not be successful in all cases. The TRE may be ended at any stage if monitoring finds there is no longer toxicity.

VI. LAND DISCHARGE MONITORING REQUIREMENTS

A. Monitoring Location LND-001

- 1. The Discharger shall monitor wastewater applied to the Land Application Areas at Monitoring Location LND-001 in accordance with Table E-4 and the testing requirements described in section VI.A.2 below:

Table E-4. Land Discharge Monitoring Requirements

Parameter	Units	Sample Type	Minimum Sampling Frequency
Biochemical Oxygen Demand, 5-day @ 20°Celcius	mg/L	Grab	1/Week
Electrical Conductivity @ 25°Celcius	µmhos/cm	Grab	1/Week
Fixed Dissolved Solids	mg/L	Grab	1/Week
Total Dissolved Solids	mg/L	Grab	1/Week
Total Nitrogen	mg/L	Grab	1/Week

- 2. **Table E-4 Testing Requirements.** The Discharger shall comply with the following testing requirements when monitoring for the parameters described in Table E-4:

- a. **Applicable to all parameters.** Parameters shall be analyzed using the analytical methods described in 40 CFR part 136 or by methods approved by the Central Valley Water Board or the State Water Board. In addition, if requested by the Discharger, the sample type may be modified by the Executive Officer to another 40 CFR part 136 allowed sample type.

B. Land Application Area Monitoring

- 1. The Discharger shall monitor the land application areas daily during operation, and shall submit the results in the corresponding monthly monitoring reports. Evidence of erosion, field saturation, runoff, or the presence of nuisance conditions shall be noted in the report. The report shall also document any corrective actions taken based on the observations made.

The Discharger shall perform the following routine monitoring and loading calculations for each LAA field during all months when land application occurs, and shall present the data in the Monthly and Annual Monitoring Reports. If irrigation does not occur during a reporting period, the monitoring report shall so indicate in accordance with Table E-5 and the testing requirements described in section VI.B.2 below:

Table E-5. Land Application Area Monitoring Requirements

Parameter	Units	Sample Type	Minimum Sampling Frequency	Reporting Frequency
Precipitation	0.1 inches (in)	Rain Gauge	1/Day	1/Month
Hydraulic Loading Rate	in	Calculate	1/Day	1/Month 1/Year
BOD5 loading rate as an irrigation cycle average	Pounds per acre per day (lb/ac/day)	Calculate	1/Day	1/Month
Total Nitrogen loading rate	lb/ac	Calculate	1/Week	1/Month 1/Year
Calendar Annual Average Total Dissolved Solids	mg/L	Calculate	1/Week	1/Year

- 2. **Table E-5 Testing Requirements.** The Discharger shall comply with the following testing requirements when monitoring for the parameters described in Table E-5:
 - a. **Rain Gauge.** Data obtained from the nearest National Weather Service, California Irrigation Management Information System (CIMIS), or on-site rain gauge is acceptable.

- b. **Hydraulic Loading Rate** shall be calculated for each LAA field. Volumes can be estimated based on the duration of flow, the number of checks being irrigated at any one time, and the daily flow rates for each field. Calculations and assumptions shall be clearly documented.
- c. **BOD5 Loading Rate** shall be calculated for each LAA field. BOD5 loading rate shall be calculated using the daily applied volume of wastewater (representative of wastewater measured at LND-001), actual application area, average of the three most recent BOD5 results for the wastewater, and the number of days per irrigation cycle.
- d. **Total Nitrogen Loading Rate** shall be calculated for each LAA field. Total nitrogen loading rates shall be calculated using the applied volume of wastewater (representative of wastewater measured at LND-001), actual application area, average of the three most recent total nitrogen results for the wastewater, and supplemental nitrogen (including commercial fertilizers, etc.).
- e. **Calendar annual average TDS** concentration to be calculated as the average of all TDS data collected at LND-001 during the calendar year.

C. Agricultural Field Inspections

- 1. The Discharger shall inspect the land application areas at least once daily during irrigation events, and observations from those inspections shall be documented for inclusion in the monthly SMRs. The following items shall be documented for each field to be irrigated on that day.
 - a. Evidence of erosion;
 - b. Evidence of berm or levee damage or erosion;
 - c. Evidence of damage to standpipes and flow control valve (if applicable);
 - d. Evidence of improper use of valves;
 - e. Condition of head ditch;
 - f. Soil saturation;
 - g. Ponding;
 - h. Evidence of damage to tailwater ditches and evidence of potential and actual runoff to off-site areas;
 - i. Evidence of potential and actual discharge to surface water;
 - j. Accumulation of organic solids in ditches and at soil surface;

- k. Soil clogging;
- l. Odors that have the potential to be objectionable at or beyond the property boundary;
- m. Evidence of fly and/or mosquito breeding; and
- n. Temperature, wind direction and relative strength; and other relevant field conditions shall also be observed and recorded. The notation shall also document any corrective actions taken based on observations made, including fresh water flushing of the force main and head water ditches. A copy of the entries made in the log during each month shall be submitted as part of the monthly self-monitoring report.

VII. RECYCLING MONITORING REQUIREMENTS

A. Monitoring Location REC-001

- 1. The Discharger shall monitor disinfected tertiary treated effluent at Monitoring Location REC-001 in accordance with Table E-6 and the testing requirements described in section VII.A.2 below:

Table E-6. Recycled Water Monitoring Requirements

Parameter	Units	Sample Type	Minimum Sampling Frequency
Flow	Gallons per day (GDP)	Meter	Continuous

- 2. **Table E-6 Testing Requirements.** The Discharger shall comply with the following testing requirements when monitoring for the parameters described in Table E-6:
 - a. Recycled water monitoring shall be reported annually with the Recycled Water Policy Annual Report.

VIII. RECEIVING WATER MONITORING REQUIREMENTS

The Discharger is required to participate in the Delta Regional Monitoring Program. Delta Regional Monitoring Program data is not intended to be used directly to represent either upstream or downstream water quality for purposes of determining compliance with this Order. Delta Regional Monitoring Program monitoring stations are established generally as “integrator sites” to evaluate the combined impacts on water quality of multiple discharges into the Delta; Delta Regional Monitoring Program monitoring stations would not normally be able to identify the source of any specific constituent but would be used to identify water quality issues needing further evaluation. Delta Regional Monitoring Program monitoring data, along with the individual Discharger data, may be used to help establish background receiving water quality for reasonable potential analyses (RPAs) in an NPDES permit after evaluation of the applicability of the data for that purpose. Delta

Regional Monitoring Program data, as with all environmental monitoring data, can provide an assessment of water quality at a specific place and time that can be used in conjunction with other information, such as other receiving water monitoring data, spatial and temporal distribution and trends of receiving water data, effluent data from the Discharger’s discharge and other point and non-point source discharges, receiving water flow volume, speed and direction, and other information to determine the likely source or sources of a constituent that resulted in the exceedance of a water quality objective.

A. Monitoring Locations RSW-001 and RSW-002

1. The Discharger shall monitor the San Joaquin River at Monitoring Locations RSW-001 and RSW-002 in accordance with Table E-7 and the testing requirements described in section VIII.A.2 below:

Table E-7. Receiving Water Monitoring Requirements

Parameter	Units	Sample Type	Minimum Sampling Frequency
Flow	Cubic feet per second (cfs)	Meter	Continuous
Dissolved Organic Carbon	mg/L	Grab	1/Quarter
Dissolved Oxygen	mg/L	Grab	2/Month
Electrical Conductivity @ 25°C	µmhos/cm	Grab	2/Month
Hardness, Total (as CaCO ₃)	mg/L	Grab	1/Quarter
pH	Standard units	Grab	1/Month
Temperature	°F	Grab	2/Month
Turbidity	NTU	Grab	2/Month

2. **Table E-7 Testing Requirements.** The Discharger shall comply with the following testing requirements when monitoring for the parameters described in Table E-7:
 - a. **Applicable to all parameters.** Parameters shall be analyzed using the analytical methods described in 40 CFR part 136 or by methods approved by the Central Valley Water Board or the State Water Board. In addition, if requested by the Discharger, the sample type may be modified by the Executive Officer to another 40 CFR part 136 allowed sample type.
 - b. Samples shall be monitored on the same day as effluent monitoring samples.
 - c. **Flow.** Flow monitoring is only required at RSW-001. In lieu of collecting a sample at RSW-001, flow data may be reported from the Department of Water Resources Monitoring Station at Mossdale Bridge (MSD).

3. In conducting the receiving water sampling, a log shall be kept of the receiving water conditions throughout the reach bounded by RSW-001 and RSW-002 discharging to the San Joaquin River. Attention shall be given to the presence of:
 - a. Floating or suspended matter;
 - b. Discoloration;
 - c. Bottom deposits;
 - d. Aquatic life;
 - e. Visible films, sheens, or coatings;
 - f. Fungi, slimes, or objectionable growths; and
 - g. Potential nuisance conditions.

Notes on receiving water conditions shall be summarized in the monitoring report.

B. Monitoring Locations MW-3, MW-4, MW-5, MW-9W, MW-11, and MW-AW

1. The Discharger shall monitor the groundwater at Monitoring Locations MW-3, MW-4, MW-5, MW-9W, MW-11, and MW-AW in accordance with Table E-8 and the testing requirements described in section VIII.B.2 below as follows:

Table E-8. Groundwater Monitoring Requirements

Parameter	Units	Sample Type	Minimum Sampling Frequency
Depth to Groundwater	0.01 feet	Measurement	1/Quarter
Groundwater Elevation	0.01 feet	Calculate	1/Quarter
Gradient	Feet/feet	Calculate	1/Quarter
Gradient Direction	Degrees	Calculate	1/Quarter
Ammonia as (NH ₄)	mg/L	Grab	1/Quarter
Boron, Total Recoverable	mg/L	Grab	1/Quarter
Chloride	mg/L	Grab	1/Quarter
Electrical Conductivity @ 25°	µmhos/cm	Grab	1/Quarter
Fixed Dissolved Solids	mg/L	Grab	1/Quarter
Iron	mg/L	Grab	1/Quarter
Manganese	mg/L	Grab	1/Quarter
Nitrate Nitrogen, Total (as N)	mg/L	Grab	1/Quarter
pH	Standard units	Grab	1/Quarter
Sodium	mg/L	Grab	1/Quarter
Total Coliform Organisms	MPN/100 mL	Grab	1/Quarter

Parameter	Units	Sample Type	Minimum Sampling Frequency
Total Dissolved Solids	mg/L	Grab	1/Quarter
Total Nitrogen	mg/L	Grab	1/Quarter

2. **Table E-8 Testing Requirements.** The Discharger shall comply with the following testing requirements when monitoring for the parameters described in Table E-8:
- a. **Applicable to all parameters.** Parameters shall be analyzed using the analytical methods described in 40 CFR part 136 or by methods approved by the Central Valley Water Board or the State Water Board. In addition, if requested by the Discharger, the sample type may be modified by the Executive Officer to another 40 CFR part 136 allowed sample type.
 - b. **Prior to construction and/or beginning a sampling program of any new groundwater monitoring wells,** the Discharger shall submit plans and specifications to the Central Valley Water Board for approval. Once installed, all new wells shall be added to the monitoring network (which currently consists of Monitoring Wells MW-3, MW-4, MW-5, MW-9W, MW11, and MW-AW) and shall be sampled and analyzed according to the schedule below. All samples shall be collected using approved EPA methods.
 - c. **Prior to sampling,** the groundwater elevations shall be measured, and the wells shall be purged of at least three well volumes until temperature, pH, and electrical conductivity have stabilized. Depth to groundwater shall be measured to the nearest 0.01 feet.
 - d. **Groundwater elevation** shall be determined based on depth-to-water measurements from a surveyed measuring point elevation on the well. The groundwater elevation shall be used to calculate the direction and gradient of groundwater flow, which must be reported.
 - e. Results for **iron and manganese** shall be evaluated from samples that have been passed through a 1.5-micron filter to evaluate compliance with the Secondary MCL criteria.

IX. OTHER MONITORING REQUIREMENTS

A. Biosolids

1. Monitoring Location BIO-001

- a. See Annual Pretreatment Reporting Requirements in section X.D.5, below.

- b. Biosolids monitoring shall be conducted using the methods in Test Methods for Evaluating Solid Waste, Physical/Chemical methods (EPA publication SW-846), as required in 40 C.F.R. section 503.8(b)(4). All results must be reported on a 100% dry weight basis. Records of all analyses must state on each page of the laboratory report whether the results are expressed in “100% dry weight” or “as is.”

B. Filtration System and Ultraviolet Light (UV) Disinfection System

- 1. **Monitoring Locations UVS-001 and FIL-001.** When discharging to surface water and/or producing Title 22 disinfected tertiary recycled water for reclamation/reuse, the Discharger shall monitor the filtration system at Monitoring Location FIL-001 and the UV disinfection system at Monitoring Locations UVS-001 in accordance with Table E-9 and the testing requirements described in section IX.B.2 below:

Table E-9. Filtration System and UV Disinfection System Monitoring Requirements

Parameter	Units	Sample Type	Monitoring Location	Minimum Sampling Frequency
Flow	MGD	Meter	UVS-001	Continuous
Number of UV banks in operation	Number	Observation	N/A	Continuous
UV Transmittance	Percent (%)	Meter	UVS-001	Continuous
UV Dose	mJ/cm ²	Calculate	N/A	Continuous
Total Coliform Organisms	MPN/100mL	Grab	UVS-001	1/Day
Turbidity	NTU	Meter	FIL-001	Continuous

- 2. **Table E-9 Testing Requirements.** The Discharger shall comply with the following testing requirements when monitoring for the parameters described in Table E-9:
 - a. **Applicable to all parameters.** Parameters shall be analyzed using the analytical methods described in 40 CFR part 136; or by methods approved by the Central Valley Water Board or the State Water Board. In addition, if requested by the Discharger, the sample type may be modified by the Executive Officer to another 40 CFR part 136 allowed sample type.
 - b. **Continuous analyzers.** The Discharger shall report documented routine meter maintenance activities including date, time of day, and duration, in which the analyzer(s) is not in operation. If analyzer(s) fail to provide continuous monitoring for more than two hours and influent and/or effluent from the disinfection process is not diverted for retreatment, the Discharger shall obtain and report hourly manual and/or grab sample results.

- c. **Turbidity.** Report daily average and maximum turbidity.
- d. **UV Dose.** Report daily minimum hourly average UV dose and daily average UV dose. The minimum hourly average dose shall consist of lowest hourly average dose provided in any channel that had at least one bank of lamps operating during the hour interval. For channels that did not operate for the entire hour interval, the dose will be averaged based on the actual operation time.
- e. **Total Coliform Organisms.** Samples for total coliform organisms may be collected at any point following disinfection.

C. Treatment Pond Monitoring

- 1. **Monitoring Locations PND-001, PND-002, and PND-003.** The Discharger shall monitor wastewater impounded at Monitoring Locations PND-001, PND-002, and PND-003 in accordance with Table E-10 and the testing requirements described in section IX.C.2 below:

Table E-10. Pond Monitoring Requirements

Parameter	Units	Sample Type	Minimum Sampling Frequency
Dissolved Oxygen	Mg/L	Grab	1/Week
Freeboard	Feet	Measure	1/Week

- 2. **Table E-10 Testing Requirements.** The Discharger shall comply with the following testing requirements when monitoring for the parameters described in Table E-10:
 - a. **Handheld Field Meter.** A handheld field meter may be used for **dissolved oxygen** provided the meter utilizes a U.S. EPA-approved algorithm/method and is calibrated and maintained in accordance with the manufacturer's instructions. A calibration and maintenance log for each meter used for monitoring required by this Monitoring and Reporting Program shall be maintained at the Facility.

D. Pyrethroid Pesticides Monitoring.

The Discharger conducted pyrethroid pesticides baseline monitoring required by Order R5-2021-0003. This Order does not require further pyrethroid pesticides monitoring at this time.

E. Effluent and Receiving Water Characterization

Since the Discharger is participating in the Delta Regional Monitoring Program as described in Attachment E, section VIII, this section only requires effluent characterization monitoring. **However, the Report of Waste Discharge (ROWD)**

for the next permit renewal shall include, at minimum, one representative ambient background characterization monitoring event for priority pollutant constituents located in Appendix A to 40 C.F.R. part 423 during the term of the permit. The ambient background characterization monitoring event shall be conducted at Monitoring Location RSW-001 between **1 August 2027 and 31 July 2028**. Data from the Delta Regional Monitoring Program may be utilized to characterize the receiving water in the permit renewal. Alternatively, the Discharger may conduct any site-specific receiving water monitoring deemed appropriate by the Discharger and submit that monitoring data with the ROWD. In general, monitoring data from samples collected in the immediate vicinity of the discharge will be given greater weight in permitting decisions than receiving water monitoring data collected at greater distances from the discharge point.

1. Monitoring Frequency

- a. **Effluent Sampling.** Samples shall be collected from the effluent (Monitoring Location EFF-001) bi-monthly (every other month) between **1 August 2027 and 31 July 2028**.
2. **Analytical Methods.** Constituents shall be collected and analyzed consistent with the Discharger's Analytical Methods Report (MRP, X.D.2) using sufficiently sensitive analytical methods and Reporting Levels (RLs) per the SSM Rule specified in 40 C.F.R. 122.21(e)(3) and 122.44(i)(1)(iv). The "Reporting Level" is synonymous with the "Method Minimum Level" described in the SSM Rule. The results of the monitoring shall be submitted to the Central Valley Water Board with the quarterly self-monitoring reports. Each individual monitoring event shall provide representative sample results for the effluent and upstream receiving water, if receiving water is sampled.
3. **Analytical Methods Report Certification.** Prior to beginning the Effluent and Receiving Water Characterization monitoring, the Discharger shall provide a certification acknowledging the scheduled start date of the Effluent and Receiving Water Characterization monitoring and confirming that samples will be collected and analyzed as described in the previously submitted Analytical Methods Report. If there are changes to the previously submitted Analytical Methods Report, the Discharger shall outline those changes. A one-page certification form will be provided by Central Valley Water Board staff with the permit's Notice of Adoption that the Discharger can use to satisfy this requirement. The certification form shall be submitted electronically via CIWQS submittal by the due date in the Technical Reports Table E-13.
4. The Discharger shall conduct effluent and receiving water characterization monitoring in accordance with Table E-11 and the testing requirements described in section IX.E.5 below.

Table E-11. Effluent and Receiving Water Characterization Monitoring

VOLATILE ORGANICS

CTR Number	Volatile Organic Parameters	CAS Number	Units	Effluent Sample Type
25	2-Chloroethyl vinyl Ether	110-75-8	µg/L	Grab
17	Acrolein	107-02-8	µg/L	Grab
18	Acrylonitrile	107-13-1	µg/L	Grab
19	Benzene	71-43-2	µg/L	Grab
20	Bromoform	75-25-2	µg/L	Grab
21	Carbon Tetrachloride	56-23-5	µg/L	Grab
22	Chlorobenzene	108-90-7	µg/L	Grab
24	Chloroethane	75-00-3	µg/L	Grab
26	Chloroform	67-66-3	µg/L	Grab
35	Methyl Chloride	74-87-3	µg/L	Grab
23	Dibromochloromethane	124-48-1	µg/L	Grab
27	Dichlorobromomethane	75-27-4	µg/L	Grab
36	Methylene Chloride	75-09-2	µg/L	Grab
33	Ethylbenzene	100-41-4	µg/L	Grab
89	Hexachlorobutadiene	87-68-3	µg/L	Grab
34	Methyl Bromide (Bromomethane)	74-83-9	µg/L	Grab
94	Naphthalene	91-20-3	µg/L	Grab
38	Tetrachloroethylene (PCE)	127-18-4	µg/L	Grab
39	Toluene	108-88-3	µg/L	Grab
40	trans-1,2-Dichloroethylene	156-60-5	µg/L	Grab
43	Trichloroethylene (TCE)	79-01-6	µg/L	Grab
44	Vinyl Chloride	75-01-4	µg/L	Grab
21	Methyl-tert-butyl ether (MTBE)	1634-04-4	µg/L	Grab
41	1,1,1-Trichloroethane	71-55-6	µg/L	Grab
42	1,1,2-Trichloroethane	79-00-5	µg/L	Grab
28	1,1-Dichloroethane	75-34-3	µg/L	Grab
30	1,1-Dichloroethylene (DCE)	75-35-4	µg/L	Grab
31	1,2-Dichloropropane	78-87-5	µg/L	Grab
32	1,3-Dichloropropylene	542-75-6	µg/L	Grab
37	1,1,2,2-Tetrachloroethane	79-34-5	µg/L	Grab
101	1,2,4-Trichlorobenzene	120-82-1	µg/L	Grab
29	1,2-Dichloroethane	107-06-2	µg/L	Grab
75	1,2-Dichlorobenzene	95-50-1	µg/L	Grab
76	1,3-Dichlorobenzene	541-73-1	µg/L	Grab
77	1,4-Dichlorobenzene	106-46-7	µg/L	Grab

SEMI-VOLATILE ORGANICS

CTR Number	Semi-Organic Volatile Parameters	CAS Number	Units	Effluent Sample Type
60	Benzo(a)Anthracene	56-55-3	µg/L	Grab
85	1,2-Diphenylhydrazine	122-66-7	µg/L	Grab
45	2-Chlorophenol	95-57-8	µg/L	Grab
46	2,4-Dichlorophenol	120-83-2	µg/L	Grab
47	2,4-Dimethylphenol	105-67-9	µg/L	Grab
49	2,4-Dinitrophenol	51-28-5	µg/L	Grab
82	2,4-Dinitrotoluene	121-14-2	µg/L	Grab
55	2,4,6-Trichlorophenol	88-06-2	µg/L	Grab
83	2,6-Dinitrotoluene	606-20-2	µg/L	Grab
50	2-Nitrophenol	88-75-5	µg/L	Grab
71	2-Chloronaphthalene	91-58-7	µg/L	Grab
78	3,3-Dichlorobenzidine	91-94-1	µg/L	Grab
62	Benzo(b)Fluoranthene	205-99-2	µg/L	Grab
52	4-Chloro-3-methylphenol	59-50-7	µg/L	Grab
48	2-Methyl-4,6-Dinitrophenol	534-52-1	µg/L	Grab
51	4-Nitrophenol	100-02-7	µg/L	Grab
69	4-Bromophenyl Phenyl Ether	101-55-3	µg/L	Grab
72	4-Chlorophenyl Phenyl Ether	7005-72-3	µg/L	Grab
56	Acenaphthene	83-32-9	µg/L	Grab
57	Acenaphthylene	208-96-8	µg/L	Grab
58	Anthracene	120-12-7	µg/L	Grab
59	Benzidine	92-87-5	µg/L	Grab
61	Benzo(a)Pyrene	50-32-8	µg/L	Grab
63	Benzo(ghi)Perylene	191-24-2	µg/L	Grab
64	Benzo(k)Fluoranthene	207-08-9	µg/L	Grab
65	Bis (2-Chloroethoxy) Methane	111-91-1	µg/L	Grab
66	Bis (2-Chloroethyl) Ether	111-44-4	µg/L	Grab
67	Bis (2-Chloroisopropyl) Ether	108-60-1	µg/L	Grab
68	Bis(2-Ethylhexyl) Phthalate	117-81-7	µg/L	Grab
70	Butylbenzyl Phthalate	85-68-7	µg/L	Grab
73	Chrysene	218-01-9	µg/L	Grab
81	Di-n-butyl Phthalate	84-74-2	µg/L	Grab
84	Di-n-Octyl Phthalate	117-84-0	µg/L	Grab
74	Dibenzo(a,h)anthracene	53-70-3	µg/L	Grab
79	Diethyl Phthalate	84-66-2	µg/L	Grab
80	Dimethyl Phthalate	131-11-3	µg/L	Grab
86	Fluoranthene	206-44-0	µg/L	Grab
87	Fluorene	86-73-7	µg/L	Grab
88	Hexachlorobenzene	118-74-1	µg/L	Grab
90	Hexachlorocyclopentadiene	77-47-4	µg/L	Grab
91	Hexachloroethane	67-72-1	µg/L	Grab
92	Indeno(1,2,3-cd) Pyrene	193-39-5	µg/L	Grab
93	Isophorone	78-59-1	µg/L	Grab

CTR Number	Semi-Organic Volatile Parameters	CAS Number	Units	Effluent Sample Type
98	N-Nitrosodiphenylamine	86-30-6	µg/L	Grab
96	N-Nitrosodimethylamine	62-75-9	µg/L	Grab
97	N-Nitrosodi-n-Propylamine	621-64-7	µg/L	Grab
95	Nitrobenzene	98-95-3	µg/L	Grab
53	Pentachlorophenol (PCP)	87-86-5	µg/L	Grab
99	Phenanthrene	85-01-8	µg/L	Grab
54	Phenol	108-95-2	µg/L	Grab
100	Pyrene	129-00-0	µg/L	Grab

INORGANICS

CTR Number	Inorganic Parameters	CAS Number	Units	Effluent Sample Type
NL	Aluminum	7429-90-5	µg/L	24-hour Composite
1	Antimony, Total	7440-36-0	µg/L	24-hour Composite
2	Arsenic, Total	7440-38-2	µg/L	24-hour Composite
15	Asbestos	1332-21-4	µg/L	24-hour Composite
3	Beryllium, Total	7440-41-7	µg/L	24-hour Composite
4	Cadmium, Total	7440-43-9	µg/L	24-hour Composite
5a	Chromium, Total	7440-47-3	µg/L	24-hour Composite
6	Copper, Total	7440-50-8	µg/L	24-hour Composite
NL	Iron, Total	7439-89-6	µg/L	24-hour Composite
7	Lead, Total	7439-92-1	µg/L	24-hour Composite
8	Mercury, Total	7439-97-6	µg/L	Grab
NL	Mercury, Methyl	22967-92-6	µg/L	Grab
NL	Manganese, Total	7439-96-5	µg/L	24-hour Composite
9	Nickel, Total	7440-02-0	µg/L	24-hour Composite
10	Selenium, Total	7782-49-2	µg/L	24-hour Composite
11	Silver, Total	7440-22-4	µg/L	24-hour Composite
12	Thallium, Total	7440-28-0	µg/L	24-hour Composite
13	Zinc, Total	7440-66-6	µg/L	24-hour Composite

NON-METALS/MINERALS

CTR Number	Non-Metal/Mineral Parameters	CAS Number	Units	Effluent Sample Type
NL	Boron	7440-42-8	µg/L	24-hour Composite
NL	Chloride	16887-00-6	mg/L	24-hour Composite
14	Cyanide, Total (as CN)	57-12-5	µg/L	Grab
NL	Sulfate	14808-79-8	mg/L	24-hour Composite
NL	Sulfide (as S)	5651-88-7	mg/L	24-hour Composite

PESTICIDES/PCBs/DIOXINS

CTR Number	Pesticide/PCB/Dioxin Parameters	CAS Number	Units	Effluent Sample Type
110	4,4-DDD	72-54-8	µg/L	24-hour Composite
109	4,4-DDE	72-55-9	µg/L	24-hour Composite
108	4,4-DDT	50-29-3	µg/L	24-hour Composite
112	alpha-Endosulfan	959-98-8	µg/L	24-hour Composite
103	alpha-BHC (Benzene hexachloride)	319-84-6	µg/L	24-hour Composite
102	Aldrin	309-00-2	µg/L	24-hour Composite
113	beta-Endosulfan	33213-65-9	µg/L	24-hour Composite
104	beta-BHC (Benzene hexachloride)	319-85-7	µg/L	24-hour Composite
107	Chlordane	57-74-9	µg/L	24-hour Composite
106	delta-BHC (Benzene hexachloride)	319-86-8	µg/L	24-hour Composite
111	Dieldrin	60-57-1	µg/L	24-hour Composite
114	Endosulfan Sulfate	1031-07-8	µg/L	24-hour Composite
115	Endrin	72-20-8	µg/L	24-hour Composite
116	Endrin Aldehyde	7421-93-4	µg/L	24-hour Composite
117	Heptachlor	76-44-8	µg/L	24-hour Composite
118	Heptachlor Epoxide	1024-57-3	µg/L	24-hour Composite
105	gamma-BHC (Benzene hexachloride or Lindane)	58-89-9	µg/L	24-hour Composite
119	Polychlorinated Biphenyl (PCB) 1016	12674-11-2	µg/L	24-hour Composite
120	PCB 1221	11104-28-2	µg/L	24-hour Composite
121	PCB 1232	11141-16-5	µg/L	24-hour Composite
122	PCB 1242	53469-21-9	µg/L	24-hour Composite
123	PCB 1248	12672-29-6	µg/L	24-hour Composite
124	PCB 1254	11097-69-1	µg/L	24-hour Composite
125	PCB 1260	11096-82-5	µg/L	24-hour Composite
126	Toxaphene	8001-35-2	µg/L	24-hour Composite
16	2,3,7,8-TCDD (Dioxin)	1746-01-6	mg/L	24-hour Composite

CONVENTIONAL PARAMETERS

CTR Number	Conventional Parameters	CAS Number	Units	Effluent Sample Type
NL	pH	--	SU	Grab
NL	Temperature	--	°F	Grab

NON-CONVENTIONAL PARAMETERS

CTR Number	Nonconventional Parameters	CAS Number	Units	Effluent Sample Type
NL	Foaming Agents (MBAS)	MBAS	mg/L	24-hour Composite
NL	Hardness (as CaCO3)	471-34-1	mg/L	Grab
NL	Specific Conductance (Electrical Conductivity or EC)	EC	µmhos/cm	24-hour Composite
NL	Total Dissolved Solids (TDS)	TDS	mg/L	24-hour Composite

CTR Number	Nonconventional Parameters	CAS Number	Units	Effluent Sample Type
NL	Dissolved Organic Carbon (DOC)	DOC	mg/L	24-hour Composite

NUTRIENTS

CTR Number	Nutrient Parameters	CAS Number	Units	Effluent Sample Type
NL	Ammonia (as N)	7664-41-7	mg/L	24-hour Composite
NL	Nitrate (as N)	14797-55-8	mg/L	24-hour Composite
NL	Nitrite (as N)	14797-65-0	mg/L	24-hour Composite
NL	Phosphorus, Total (as P)	7723-14-0	mg/L	24-hour Composite

OTHER CONSTITUENTS OF CONCERN

CTR Number	Other Constituents of Concern	CAS Number	Units	Effluent Sample Type
NL	1,2,3-Trichloropropane (TCP)	96-18-4	µg/L	Grab
NL	Trichlorofluoromethane	75-69-4	µg/L	Grab
NL	1,1,2-Trichloro-1,2,2-Trifluoroethane	76-13-1	µg/L	Grab
NL	Styrene	100-42-5	µg/L	Grab
NL	Xylenes	1330-20-7	µg/L	Grab
NL	Barium	7440-39-3	µg/L	24-hour Composite
NL	Fluoride	16984-48-8	mg/L	24-hour Composite
NL	Molybdenum	7439-98-7	µg/L	24-hour Composite
NL	Tributyltin	688-73-3	µg/L	24-hour Composite
NL	Alachlor	15972-60-8	µg/L	24-hour Composite
NL	Atrazine	1912-24-9	µg/L	24-hour Composite
NL	Bentazon	25057-89-0	µg/L	24-hour Composite
NL	Carbofuran	1563-66-2	µg/L	24-hour Composite
NL	2,4-D	94-75-7	µg/L	24-hour Composite
NL	Dalapon	75-99-0	µg/L	24-hour Composite
NL	1,2-Dibromo-3-chloropropane (DBCP)	96-12-8	µg/L	24-hour Composite
NL	Di(2-ethylhexyl)adipate	103-23-1	µg/L	24-hour Composite
NL	Dinoseb	88-85-7	µg/L	24-hour Composite
NL	Diquat	85-00-7	µg/L	24-hour Composite
NL	Endothal	145-73-3	µg/L	24-hour Composite
NL	Ethylene Dibromide (EDB)	106-93-4	µg/L	24-hour Composite
NL	Methoxychlor	72-43-5	µg/L	24-hour Composite
NL	Molinate (Ordram)	2212-67-1	µg/L	24-hour Composite
NL	Oxamyl	23135-22-0	µg/L	24-hour Composite
NL	Picloram	1918-02-1	µg/L	24-hour Composite
NL	Simazine (Princep)	122-34-9	µg/L	24-hour Composite
NL	Thiobencarb	28249-77-6	µg/L	24-hour Composite
NL	2,4,5-TP (Silvex)	93-72-1	µg/L	24-hour Composite
NL	Chlorpyrifos	2921-88-2	µg/L	24-hour Composite

CTR Number	Other Constituents of Concern	CAS Number	Units	Effluent Sample Type
NL	Diazinon	333-41-5	µg/L	24-hour Composite

5. **Table E-11 Testing Requirements.** The Discharger shall comply with the following testing requirements when monitoring for the parameters described in Table E-11:
- a. **Applicable to All Parameters.** Pollutants shall be analyzed using the analytical methods described in 40 C.F.R. Part 136 or by methods approved by the Central Valley Water Board or the State Water Board.
 - b. **Grab Samples.** A grab sample is defined as an individual discrete sample collected over a period of time not exceeding 15 minutes. It can be taken manually, using a pump, scoop, vacuum, or other suitable device.
 - c. **24-hour Composite Samples.** All 24-hour composite samples shall be collected from a 24-hour flow proportional composite.
 - d. **Redundant Sampling.** The Discharger is not required to conduct effluent monitoring for constituents that have already been sampled in a given month, as required in Table E-3, with the exception of hardness which shall be sampled concurrently with the hardness-dependent metals (cadmium, chromium III, lead, nickel, silver, and zinc).
 - e. **Concurrent Sampling.** Effluent and receiving water sampling shall be performed at approximately the same time, on the same date.
 - f. **Sample Type.** All receiving water samples shall be taken as grab samples. Effluent samples shall be taken as described in Table E-11.
 - g. **Bis (2-ethylhexyl) phthalate.** In order to verify if bis (2-ethylhexyl) phthalate is truly present, the Discharger shall take steps to assure that sample containers, sampling apparatus, and analytical equipment are not sources of the detected contaminant.
 - h. **Total Mercury and Methylmercury.** Unfiltered methylmercury and total mercury samples shall be taken using clean hands/dirty hands procedures, as described in U.S. EPA method 1669: Sampling Ambient Water for Trace Metals at EPA Water Quality Criteria Levels, for collection of equipment blanks (section 9.4.4.2). The analysis of methylmercury and total mercury shall be by U.S. EPA method 1630 and 1631 (Revision E), respectively, with a reporting limit of 0.05 ng/L for methylmercury and 0.5 ng/L for total mercury.
 - i. **Ammonia (as N).** Sampling is only required in the upstream receiving water.
 - j. **Chlorpyrifos and Diazinon** shall be sampled using U.S. EPA Method 625M, Method 8141, or equivalent GC/MS method with a lower Reporting Limit than the Basin Plan Water Quality Objectives of 0.015 µg/L and 0.1 µg/L for chlorpyrifos and diazinon, respectively.

X. REPORTING REQUIREMENTS

A. General Monitoring and Reporting Requirements

1. The Discharger shall comply with all Standard Provisions (Attachment D) related to monitoring, reporting, and recordkeeping.
2. Upon written request of the Central Valley Water Board, the Discharger shall submit a summary monitoring report. The report shall contain both tabular and graphical summaries of the monitoring data obtained during the previous year(s).
3. **Compliance Time Schedules.** For compliance time schedules included in the Order, the Discharger shall submit to the Central Valley Water Board, on or before each compliance due date, the specified document or a written report detailing compliance or noncompliance with the specific date and task. If noncompliance is reported, the Discharger shall state the reasons for noncompliance and include an estimate of the date when the Discharger will be in compliance. The Discharger shall notify the Central Valley Water Board by letter when it returns to compliance with the compliance time schedule.
4. The Discharger shall report to the Central Valley Water Board any toxic chemical release data it reports to the State Emergency Response Commission within 15 days of reporting the data to the Commission pursuant to section 313 of the "Emergency Planning and Community Right to Know Act" of 1986.

B. Self-Monitoring Reports (SMRs)

1. The Discharger shall electronically submit SMRs using the State Water Board's [California Integrated Water Quality System \(CIWQS\) Program website](http://www.waterboards.ca.gov/water_issues/programs/ciwqs/) (http://www.waterboards.ca.gov/water_issues/programs/ciwqs/). The CIWQS website will provide additional information for SMR submittal in the event there will be a planned service interruption for electronic submittal.
2. The Discharger shall report in the SMR the results for all monitoring specified in this MRP under sections III through IX. The Discharger shall submit monthly, quarterly, and annual SMRs including the results of all required monitoring using U.S. EPA-approved test methods or other test methods specified in this Order. SMRs are to include all new monitoring results obtained since the last SMR was submitted. If the Discharger monitors any pollutant more frequently than required by this Order, the results of this monitoring shall be included in the calculations and reporting of the data submitted in the SMR. Monthly SMRs are required even if there is no discharge. If no discharge occurs during the month, the monitoring report must be submitted stating that there has been no discharge.
3. Monitoring periods and reporting for all required monitoring shall be completed according to the following schedule:

Table E-12. Monitoring Periods and Reporting Schedule

Sampling Frequency	Monitoring Period Begins On	Monitoring Period	SMR Due Date
Continuous	Permit effective date	All	Submit with monthly SMR
1/Day	Permit effective date	(Midnight through 11:59 PM) or any 24-hour period that reasonably represents a calendar day for purposes of sampling.	Submit with monthly SMR
1/Week	Permit effective date	Sunday through Saturday	Submit with monthly SMR
3/Week	Permit effective date	Sunday through Saturday	Submit with monthly SMR
1/Month	Permit effective date	1st day of calendar month through last day of calendar month	First day of second calendar month following month of sampling
2/Month	Permit effective date	1st day of calendar month through last day of calendar month	First day of second calendar month following month of sampling
1/Quarter	Permit effective date	1 January through 31 March 1 April through 30 June 1 July through 30 September 1 October through 31 December	1 May 1 August 1 November 1 February of following year
1/Year	Permit effective date	1 January through 31 December	1 February of following year

4. **Reporting Protocols.** The Discharger shall report with each sample result the applicable Reporting Level (RL) and the current laboratory’s Method Detection Limit (MDL), as determined by the procedure in 40 C.F.R. part 136.

The Discharger shall report the results of analytical determinations for the presence of chemical constituents in a sample using the following reporting protocols:

- a. Sample results greater than or equal to the RL shall be reported as measured by the laboratory (i.e., the measured chemical concentration in the sample).
- b. Sample results less than the RL, but greater than or equal to the laboratory’s MDL, shall be reported as “Detected, but Not Quantified,” or DNQ. The estimated chemical concentration of the sample shall also be reported.

For the purposes of data collection, the laboratory shall write the estimated chemical concentration next to DNQ. The laboratory may, if such information is available, include numerical estimates of the data quality for the reported result. Numerical estimates of data quality may be percent accuracy (\pm a percentage of the reported value), numerical ranges (low to high), or any other means considered appropriate by the laboratory.

- c. Sample results less than the laboratory's MDL shall be reported as "Not Detected," or ND.
 - d. Dischargers are to instruct laboratories to establish calibration standards so that the Minimum Level (ML) value (or its equivalent if there is differential treatment of samples relative to calibration standards) is the lowest calibration standard. At no time is the Discharger to use analytical data derived from extrapolation beyond the lowest point of the calibration curve.
5. **Multiple Sample Data.** When determining compliance with an AMEL, AWEL, or MDEL for priority pollutants and more than one sample result is available, the Discharger shall compute the arithmetic mean unless the data set contains one or more reported determinations of "Detected, but Not Quantified" (DNQ) or "Not Detected" (ND). In those cases, the Discharger shall compute the median in place of the arithmetic mean in accordance with the following procedure:
- a. The data set shall be ranked from low to high, ranking the reported ND determinations lowest, DNQ determinations next, followed by quantified values (if any). The order of the individual ND or DNQ determinations is unimportant.
 - b. The median value of the data set shall be determined. If the data set has an odd number of data points, then the median is the middle value. If the data set has an even number of data points, then the median is the average of the two values around the middle unless one or both of the points are ND or DNQ, in which case the median value shall be the lower of the two data points where DNQ is lower than a value and ND is lower than DNQ.
6. **The Discharger shall submit SMRs** in accordance with the following requirements:
- a. The Discharger shall arrange all reported data in a tabular format. The data shall be summarized to clearly illustrate whether the facility is operating in compliance with interim and/or final effluent limitations. The Discharger is not required to duplicate the submittal of data that is entered in a tabular format within CIWQS. When electronic submittal of data is required and CIWQS does not provide for entry into a tabular format within

- the system, the Discharger shall electronically submit the data in a tabular format as an attachment.
- b. The Discharger shall attach a cover letter to the SMR. The information contained in the cover letter shall clearly identify violations of the waste discharge requirements; discuss corrective actions taken or planned; and the proposed time schedule for corrective actions. Identified violations must include a description of the requirement that was violated and a description of the violation.
 - c. The Discharger shall attach all final laboratory reports from all contracted commercial laboratories, including quality assurance/quality control information, with all its SMRs for which sample analyses were performed.
7. The Discharger shall submit in the SMRs calculations and reports in accordance with the following requirements:
- a. **Mass Loading Limitations.** For ammonia, the Discharger shall calculate and report the average weekly and average monthly mass loading (lbs/day) in the SMRs. The mass loading shall be calculated as follows:

$$\text{Mass Loading (lbs/day)} = \text{Total Flow (million gallons)} \times \text{Concentration (mg/L)} \times 8.34 \text{ divided by Period Length (days)}$$

The weekly average constituent concentration and total weekly flow shall be used for average weekly mass loading. The monthly average constituent concentration and total monthly flow shall be used for average monthly mass loading.
 - b. **Chlorpyrifos and Diazinon Effluent Limitations.** The Discharger shall calculate and report the value of SAMEL and SAWEL for the effluent, using the equations in section IV.A.1.d of the Order, and consistent with the Compliance Determination Language in section VII.D of the Waste Discharge Requirements.
 - c. **Removal Efficiency (BOD₅ and TSS).** The Discharger shall calculate and report the percent removal of BOD₅ and TSS in the SMRs. The percent removal shall be calculated as specified in section VII.B of the Waste Discharge Requirements.
 - d. **Total Coliform Organisms Effluent Limitations.** The Discharger shall calculate and report the 7-day median of total coliform organisms for the effluent. The 7-day median of total coliform organisms shall be calculated as specified in section VII.G of the Waste Discharge Requirements.
 - e. **Total Calendar Annual Mass Loading Mercury Effluent Limitations.** The Discharger shall calculate and report the total calendar annual

mercury mass loading for the effluent in the Annual SMR. The total calendar annual mass loading values shall be calculated as specified in section VII.E of the Waste Discharge Requirements.

- f. **Temperature Effluent Limitation.** For every day receiving water temperature samples are collected, the Discharger shall calculate and report the difference between the effluent temperature and the “upstream” receiving water temperature based on the difference in the effluent temperature at Monitoring Location EFF-001 and upstream receiving water temperature of grab samples collected at Monitoring Location RSW-001 or RSW-002, depending on which location is considered upstream based on the direction of San Joaquin River flow at the time of sampling. Due to the tidal nature of the receiving water, the direction of flow in the San Joaquin River shall be recorded at the time of sampling to ascertain which location (i.e., Monitoring Location RSW-001 or Monitoring Location RSW-002) is “upstream” or “downstream” of the Facility’s discharge. Averaging periods shall be consistent with Section VII.F of the Waste Discharge Requirements.

C. Discharge Monitoring Reports (DMRs)

1. DMRs are U.S. EPA reporting requirements. The Discharger shall electronically certify and submit DMRs together with SMRs using Electronic Self-Monitoring Reports module eSMR 2.5 or any upgraded version. Electronic DMR submittal will be in addition to electronic SMR submittal. [Information about electronic DMR submittal](#) (http://www.waterboards.ca.gov/water_issues/programs/discharge_monitoring/) is available on the Internet.

D. Other Reports

1. **Analytical Methods Report.** The Discharger shall complete and submit an Analytical Methods Report, electronically via CIWQS submittal, by the due date shown in the Technical Reports Table E-13. The Analytical Methods Report shall include the following for each constituent to be monitored in accordance with this Order: 1) applicable water quality objective, 2) reporting level (RL), 3) method detection limit (MDL), and 4) analytical method. The analytical methods shall be sufficiently sensitive with RLs consistent with the SSM Rule per 40 C.F.R. 122.21(e)(3) and 122.44(i)(1)(iv), and with the Minimum Levels (MLs) in the SIP, Appendix 4. The “Reporting Level or RL” is synonymous with the “Method Minimum Level” described in the SSM Rule. If an RL is not less than or equal to the applicable water quality objective for a constituent, the Discharger shall explain how the proposed analytical method complies with the SSM Rule as outlined above in Attachment E, section I.F. Central Valley Water Board staff will provide a tool with the permit’s Notice of Adoption to assist the Discharger in completing this requirement. The tool will include the constituents and associated

applicable water quality objectives to be included in the Analytical Methods Report.

2. **Annual Operations Report.** The Discharger shall submit a written report to the Central Valley Water Board, electronically via CIWQS submittal, containing the following by the due date in the Technical Reports Table E-13:
 - a. The names, certificate grades, and general responsibilities of all persons employed at the Facility.
 - b. The names and telephone numbers of persons to contact regarding the plant for emergency and routine situations.
 - c. A statement certifying when the flow meter(s) and other monitoring instruments and devices were last calibrated, including identification of who performed the calibration.
 - d. A statement certifying whether the current operation and maintenance manual, and contingency plan, reflect the wastewater treatment plant as currently constructed and operated, and the dates when these documents were last revised and last reviewed for adequacy.
 - e. The Discharger may also be requested to submit an annual report to the Central Valley Water Board with both tabular and graphical summaries of the monitoring data obtained during the previous year. Any such request shall be made in writing. The report shall discuss the compliance record. If violations have occurred, the report shall also discuss the corrective actions taken and planned to bring the discharge into full compliance with the waste discharge requirements.
3. **Recycled Water Policy Annual Reports.** In accordance with section 3 of the Water Quality Control Policy for Recycled Water (Recycled Water Policy), the Discharger shall electronically submit an annual report of monthly data to the State Water Board by 30 April annually covering the previous calendar year using the State Water Board's [GeoTracker website](https://geotracker.waterboards.ca.gov/) (<https://geotracker.waterboards.ca.gov/>). Information for setting up and using the GeoTracker system can be found in the *ESI Guide for Responsible Parties* document on the State Water Board's website for [Electronic Submittal of Information](https://www.waterboards.ca.gov/ust/electronic_submittal/index.html) (https://www.waterboards.ca.gov/ust/electronic_submittal/index.html).

The annual report to GeoTracker must include volumetric reporting of the items listed in section 3.2 of the Recycled Water Policy (https://www.waterboards.ca.gov/board_decisions/adopted_orders/resolutions/2018/121118_7_final_amendment_oal.pdf). A pdf of the upload confirmation from GeoTracker for the Recycled Water Policy Annual Report shall be uploaded into CIWQS annually as a technical report per Table E-13, to demonstrate compliance with this reporting requirement.

4. **Report of Waste Discharge (ROWD).** For the 5-year permit renewal, the Discharger shall submit a written report to the Central Valley Water Board, electronically via CIWQS submittal, containing, at minimum, the following by the due date in the Technical Reports Table E-13:
 - a. Report of Waste Discharge (Form 200);
 - b. NPDES Form 1 (not needed if submitting Form 2A);
 - c. NPDES Form 2S;
 - d. **Salinity Evaluation and Minimization Plan (SEMP) Summary.** The Discharger shall evaluate the effectiveness of the SEMP and provide a summary with the Report of Waste Discharge;
 - e. **Most Sensitive Species Screening.** The Discharger shall perform subsequent species sensitivity screening to re-evaluate the most sensitive species for chronic whole effluent toxicity testing in accordance with MRP section V.F and results submitted with the ROWD; and
 - f. **Local Limits Evaluation.** In accordance with 40 C.F.R. section 122.44(j)(2)(ii) the Discharger shall provide a written technical evaluation of the need to revise the local limits under 40 C.F.R. section 403.5(c)(1).
5. **Annual Pretreatment Reporting Requirements.** The Discharger shall submit annually a report to the Central Valley Water Board, with copies to U.S. EPA Region 9 and the State Water Board, describing the Discharger's pretreatment activities over the previous 12 months (1 January through 31 December). In the event that the Discharger is not in compliance with any conditions or requirements of this Order, including noncompliance with pretreatment audit/compliance inspection requirements, then the Discharger shall also include the reasons for noncompliance and state how and when the Discharger shall comply with such conditions and requirements.

An annual report shall be submitted by the due date shown in the Technical Reports Table E-13 and include at least the following items:

- a. A summary of analytical results from representative sampling of the POTW's influent and effluent for those pollutants U.S. EPA has identified under section 307(a) of the CWA which are known or suspected to be discharged by nondomestic users. This will consist of an annual full priority pollutant scan. The sample types for each priority pollutant constituent shall be consistent with the sample types specified in Table E-11 (Effluent and Receiving Water Characterization Monitoring). The Discharger is not required to sample and analyze for asbestos. The Discharger shall submit the results of the annual priority pollutant scan electronically to the Central Valley Water Board using the State Water Board's CIWQS Program Website.

Sludge shall be sampled during the same 24-hour period and analyzed for the same pollutants as the influent and effluent sampling and analysis. The sludge analyzed shall be a **composite sample of a minimum of 12 discrete samples taken at equal time intervals over the 24-hour period**. Wastewater and sludge sampling and analysis shall be performed at least annually. The Discharger shall also provide any influent, effluent or sludge monitoring data for nonpriority pollutants which may be causing or contributing to Interference, Pass-Through or adversely impacting sludge quality. Sampling and analysis shall be performed in accordance with the techniques prescribed in 40 C.F.R. part 136 and amendments thereto;

- b. A discussion of Upset, Interference, or Pass-Through incidents, if any, at the treatment plant, which the Discharger knows, or suspects were caused by nondomestic users of the POTW. The discussion shall include the reasons why the incidents occurred, the corrective actions taken and, if known, the name and address of, the nondomestic user(s) responsible. The discussion shall also include a review of the applicable pollutant limitations to determine whether any additional limitations, or changes to existing requirements, may be necessary to prevent Pass-Through, Interference, or noncompliance with sludge disposal requirements;
- c. The cumulative number of nondomestic users that the Discharger has notified regarding Baseline Monitoring Reports and the cumulative number of nondomestic user responses;
- d. An updated list of the Discharger's significant industrial users (SIUs) including their names and addresses, or a list of deletions, additions and SIU name changes keyed to a previously submitted list. The Discharger shall provide a brief explanation for each change. The list shall identify the SIUs subject to federal categorical standards by specifying which set(s) of standards are applicable to each SIU. The list shall indicate which SIUs, or specific pollutants from each industry, are subject to local limitations. Local limitations that are more stringent than the federal categorical standards shall also be identified;
- e. The Discharger shall characterize the compliance status through the year of record of each SIU by employing the following descriptions:
 - i. complied with baseline monitoring report requirements (where applicable);
 - ii. consistently achieved compliance;
 - iii. inconsistently achieved compliance;

- iv. significantly violated applicable pretreatment requirements as defined by 40 C.F.R. section 403.8(f)(2)(vii);
 - v. complied with schedule to achieve compliance (include the date final compliance is required);
 - vi. did not achieve compliance and not on a compliance schedule; and
 - vii. compliance status unknown.
- f. A summary of the inspection and sampling activities conducted by the Discharger during the past year to gather information and data regarding the SIUs. The summary shall include:
- i. The names and addresses of the SIUs subjected to surveillance and an explanation of whether they were inspected, sampled, or both and the frequency of these activities at each user; and
 - ii. The conclusions or results from the inspection or sampling of each industrial user.
- g. The Discharger shall characterize the compliance status of each SIU by providing a list or table which includes the following information:
- i. Name of SIU;
 - ii. Category, if subject to federal categorical standards;
 - iii. The type of wastewater treatment or control processes in place;
 - iv. The number of samples taken by the POTW during the year;
 - v. The number of samples taken by the SIU during the year;
 - vi. For a SIU subject to discharge requirements for total toxic organics, whether all required certifications were provided;
 - vii. A list of the standards violated during the year. Identify whether the violations were for categorical standards or local limits;
 - viii. Whether the facility is in significant noncompliance (SNC) as defined at 40 C.F.R. section 403.8(f)(2)(viii) at any time during the year;
 - ix. A summary of enforcement or other actions taken during the year to return the SIU to compliance. Describe the type of action (e.g., warning letters or notices of violation, administrative orders, civil actions, and criminal actions), final compliance date, and the amount of fines and penalties collected, if any. Describe any proposed actions for bringing the SIU into compliance;

- x. Restriction of flow to the POTW; and
- xi. Disconnection from discharge to the POTW.
- h. A brief description of any programs the POTW implements to reduce pollutants from nondomestic users that are not classified as SIUs;
- i. A brief description of any significant changes in operating the pretreatment program which differ from the previous year including, but not limited to, changes concerning: the program's administrative structure, local limits, monitoring program or monitoring frequencies, legal-authority, enforcement policy, funding levels, or staffing levels;
- j. A summary of the annual pretreatment budget, including the cost of pretreatment program functions and equipment purchases; and
- k. A summary of activities to involve and inform the public of the program including a copy of the newspaper notice, if any, required under 40 C.F.R. section 403.8(f)(2)(viii).

Pretreatment Program reports shall be submitted electronically to the Central Valley Water Board via CIWQS submittal and the:

State Water Resources Control Board
NPDES Wastewater@waterboards.ca.gov
and the
U.S. EPA Region 9 Pretreatment Coordinator
R9Pretreatment@epa.gov

6. Land Application Area Reporting

- a. **Monthly Monitoring Reports.** The results of the required monitoring in this MRP for land discharge monitoring (MRP section VI) and treatment pond monitoring (MRP section IX.C).
 - i. Tabulated pond monitoring data.
 - ii. Tabulated daily flow measurements from each wastewater source and supplemental irrigation water to each LAA field.
 - iii. The cumulative annual wastewater (LND-001) flow discharged to the LAAs to date and the average daily flow for the month.
 - iv. Tabulated wastewater monitoring data and calculation of the running average for each group of three consecutive sample results for BOD and total nitrogen.

- v. Tabulated land application area monitoring data for each LAA field, including; calculation of the hydraulic loading, irrigation cycle average BOD loading, and total nitrogen loading to date from all sources. The average of the three most recent monitoring results shall be used to determine irrigation cycle average BOD and total nitrogen loading. Loading rates from commercial fertilizers shall be calculated separately using actual load analytical results and application areas.
- vi. A summary of the daily agricultural field inspections for the month, that includes all relevant information identified in MRP section VI.C. Agricultural Field Inspections.
- vii. Calculation of the flow-weighted average annual FDS concentration to date (measured at LND-001) using the following formula:

$$C_a = \frac{\sum_1^{12} [(C_{P_i} \times V_{P_i}) + (C_{S_i} \times V_{S_i})]}{\sum_1^{12} (V_{P_i} + V_{S_i})}$$

Where:

C_a = Flow-weighted average annual FDS concentration in mg/L

i = the number of the month (e.g., January = 1, February = 2, etc.)

C_{P_i} = Monthly average process wastewater FDS concentration for calendar month i in mg/L

C_{S_i} = Monthly average supplemental irrigation water FDS concentration for calendar month i in mg/L (considering each supplemental source separately). Supplemental irrigation water is any irrigation supply water other than wastewater produced at the Facility (e.g., groundwater supply).

V_{P_i} = Volume of process wastewater applied to LAAs during calendar month i in million gallons

V_{S_i} = Volume of supplemental irrigation water applied to LAAs during calendar month i in million gallons (considering each supplemental source separately). Supplemental irrigation water is any irrigation supply water other than wastewater produced at the Facility (e.g., groundwater supply).

- viii. A comparison of monitoring data to the effluent limitations; mass loading limitations (for each LAA field), and discharge specifications, and an explanation of any violation of those requirements.

- ix. If requested by staff, copies of laboratory analytical report(s).
 - x. Copies of current calibration logs for all field test instruments.
- b. **Quarterly Monitoring Reports.** The results of the required monitoring in this MRP for groundwater monitoring (MRP section VIII.B).
- i. Results of the quarterly monitoring of the groundwater in tabular format.
 - ii. A narrative description of all preparatory, monitoring, sampling, and analytical testing activities for the groundwater monitoring. The narrative shall be sufficiently detailed to verify compliance with the WDR, this MRP, and the Standard Provisions and Reporting Requirements. The narrative shall be supported by field logs for each well documenting depth to groundwater; parameters measured before, during, and after purging; method of purging; calculation of casing volume; and total volume of water purged.
 - iii. Calculation of groundwater elevations, determination of groundwater flow direction and gradient on the date of measurement, comparison of previous flow direction and gradient data, and discussion of seasonal trends if any.
 - iv. Summary data tables of historical (five years) and current groundwater elevations.
 - v. A scaled map showing relevant structures and features of the facility, land application areas, locations of monitoring wells and any other sampling stations, and groundwater elevation contours referenced to mean sea level datum.
 - vi. Copies of laboratory analytical report(s) for groundwater monitoring.
- c. **Annual Monitoring Reports.** An Annual Report shall be submitted to the Central Valley Water Board by the dates indicated in Technical Reports Table E-13 below each year and shall include the following:
- i. Concentration vs. time graphs for each monitored constituent using all historic groundwater monitoring data. Each graph shall show the background groundwater concentration range, the trigger concentration specified above (where applicable), and the Groundwater Limitation as horizontal lines at the applicable concentration.
 - ii. An evaluation of the groundwater quality beneath the site and determination of Compliance with the Groundwater Limitations based on statistical analysis for each constituent monitored for each compliance well. Include all calculations and data input/analysis tables derived from use of statistical software as applicable.

- iii. A discussion of compliance and the corrective actions taken, as well as any planned or proposed actions needed to bring the discharge into full compliance with the waste discharge requirements.
 - iv. Copies of laboratory analytical report(s) for groundwater monitoring.
- d. **Nutrient Management Plan Annual Report.** An Annual Report shall be prepared and shall include all monitoring data required in the monitoring schedule applicable land applications, including pond and groundwater monitoring. The Annual Report shall be submitted to the Central Valley Water Board by the dates indicated in Technical Reports Table E-13 below. In addition to the data normally presented, the Annual Report shall include the following:
- i. Tabular and graphical summaries of historical monthly total loading rates for water (hydraulic loading in gallons and inches), BOD, total nitrogen, fixed dissolved solids, and total dissolved solids.
 - ii. The flow-weighted annual average FDS concentration shall be calculated using the following formula:

$$C_a = \frac{\sum_{i=1}^{12} (C_{Pi} \times V_{Pi})}{\sum_{i=1}^{12} V_{Pi}}$$

Where:

C_a = Flow-weighted average annual FDS concentration in mg/L

i = the number of the month (e.g., January = 1, February = 2, etc.)

C_{Pi} = Monthly average process wastewater FDS concentration for calendar month i in mg/L

V_{Pi} = Volume of process wastewater applied to LAAs during calendar month i in million gallons

- iii. A mass balance relative to constituents of concern and hydraulic loading along with supporting data and calculations. The report shall describe the types of crops planted and dates of planting and harvest for each crop.
- iv. For each violation of the Discharge Specifications, applicable Prohibitions, and Groundwater Limitations of this Order, the report shall describe in detail the nature of the violation, date(s) of occurrence, cause(s), mitigation or control measures taken to prevent or stop the violation, and

additional operational or facility modifications that will be made to ensure that the violation does not occur in the following year.

- v. A comprehensive evaluation of the effectiveness of the past year's wastewater application operation in terms of odor control, including consideration of application management practices (i.e. waste constituent and hydraulic loadings, application cycles, drying times, and cropping practices), and groundwater monitoring data.
 - vi. A discussion of compliance and the corrective action taken, as well as any planned or proposed actions needed to bring the land application discharge, or groundwater limits, into full compliance with the requirements in this Order.
 - vii. A discussion of any data gaps and potential deficiencies/redundancies in the monitoring system or reporting program.
 - viii. Based on this information, the Discharger shall develop and include a Cropping and Irrigation plan for the following season.
 - ix. A current site plan depicting the irrigation checks within each LAA field that was used during the calendar year, including all water conveyance ditches and internal berms that divide each LAA (where applicable).
 - x. Tabulated cropping information for each LAA field that includes at least:
 - (a) The crop that was grown in each field;
 - (b) Planting dates;
 - (c) Harvesting dates;
 - (d) Crop total nitrogen demand; and
 - (e) Crop average evapotranspiration rate in inches.
7. **Technical Report Submittals.** This Order includes requirements to submit a ROWD, special study technical reports, progress reports, and other reports identified in the MRP (hereafter referred to collectively as "technical reports"). The Technical Reports Table E-13 and subsequent table notes below summarize all technical reports required by this Order and the due dates for submittal. All technical reports shall be submitted electronically via CIWQS submittal. Technical reports should be uploaded as a PDF, Microsoft Word, or Microsoft Excel file attachment.

Table E-13. Technical Reports

Report #	Technical Report	Due Date	CIWQS Report Name
Intentionally left blank	Standard Reporting Requirements	Intentionally left blank	Intentionally left blank
1	Report of Waste Discharge	31 July 2030	ROWD
2	Analytical Methods Report	1 November 2026	MRP X.D.1
3	Analytical Methods Report Certification	1 May 2027	MRP IX.E.2
4	Annual Operations Report	1 February 2027	MRP X.D.2
5	Annual Operations Report	1 February 2028	MRP X.D.2
6	Annual Operations Report	1 February 2029	MRP X.D.2
7	Annual Operations Report	1 February 2030	MRP X.D.2
8	Annual Operations Report	1 February 2031	MRP X.D.2
9	Recycled Water Policy Annual Report Submittal Confirmation	30 April 2027	MRP X.D.3
10	Recycled Water Policy Annual Report Submittal Confirmation	30 April 2028	MRP X.D.3
11	Recycled Water Policy Annual Report Submittal Confirmation	30 April 2029	MRP X.D.3
12	Recycled Water Policy Annual Report Submittal Confirmation	30 April 2030	MRP X.D.3
13	Recycled Water Policy Annual Report Submittal Confirmation	30 April 2031	MRP X.D.3
Intentionally left blank	Compliance Schedule for Final Effluent Limitations for Methylmercury WDR section VI.C.7.a	Intentionally left blank	Intentionally left blank
14	Mercury Pollution Prevention Plan Annual Progress Reports	1 February 2027	WDR VI.C.3.a
15	Mercury Pollution Prevention Plan Annual Progress Reports	1 February 2028	WDR VI.C.3.a
16	Mercury Pollution Prevention Plan Annual Progress Reports	1 February 2029	WDR VI.C.3.a
17	Mercury Pollution Prevention Plan Annual Progress Reports	1 February 2030	WDR VI.C.3.a
18	Notification of Full Compliance Signed by Legally Responsible Official (LRO)	31 December 2030	WDR VI.C.7.a
Intentionally left blank	Land Application Area Reporting	Intentionally left blank	Intentionally left blank
19	Land Application Area Annual Monitoring Reports	1 February 2027	MRP X.D.6.c

Report #	Technical Report	Due Date	CIWQS Report Name
20	Land Application Area Annual Monitoring Reports	1 February 2028	MRP X.D.6.c
21	Land Application Area Annual Monitoring Reports	1 February 2029	MRP X.D.6.c
22	Land Application Area Annual Monitoring Reports	1 February 2030	MRP X.D.6.c
23	Land Application Area Annual Monitoring Reports	1 February 2031	MRP X.D.6.c
24	Nutrient Management Plan Annual Report	1 March 2027	MRP X.D.6.d
25	Nutrient Management Plan Annual Report	1 March 2028	MRP X.D.6.d
26	Nutrient Management Plan Annual Report	1 March 2029	MRP X.D.6.d
27	Nutrient Management Plan Annual Report	1 March 2030	MRP X.D.6.d
28	Nutrient Management Plan Annual Report	1 March 2031	MRP X.D.6.d
Intentionally left blank	Other Reports	Intentionally left blank	Intentionally left blank
29	Annual Pretreatment Report	28 February 2027	MRP X.D.5
30	Annual Pretreatment Report	28 February 2028	MRP X.D.5
31	Annual Pretreatment Report	28 February 2029	MRP X.D.5
32	Annual Pretreatment Report	28 February 2030	MRP X.D.5
33	Annual Pretreatment Report	28 February 2031	MRP X.D.5

Table E-13 Note:

1. Beginning 1 February 2027 and annually thereafter until the Facility achieves compliance with the final effluent limitations for methylmercury, the Discharger shall submit annual progress reports on the previously-submitted pollution prevention plan for mercury. **This annual report may be combined with the Annual Operations Report and submitted as one report.** The progress reports shall discuss the effectiveness of the pollution prevention plan in the reduction of mercury in the discharge, include a summary of mercury and methylmercury monitoring results, and discuss updates to the pollution prevention plan.

ATTACHMENT F – FACT SHEET

Table of Contents

I.	Permit Information	F-3
II.	Facility Description	F-5
	A. Description of Wastewater and Biosolids Treatment and Controls	F-5
	B. Discharge Points and Receiving Waters	F-6
	C. Summary of Existing Requirements and Self-Monitoring Report (SMR) Data	F-6
	D. Compliance Summary	F-9
	E. Planned Changes	F-9
III.	Applicable Plans, Policies, and Regulations	F-10
	A. Legal Authorities	F-10
	B. California Environmental Quality Act (CEQA)	F-11
	C. State and Federal Laws, Regulations, Policies, and Plans	F-11
	D. Impaired Water Bodies on CWA 303(d) List	F-18
	E. Other Plans, Policies and Regulations	F-19
IV.	Rationale For Effluent Limitations and Discharge Specifications	F-21
	A. Discharge Prohibitions	F-21
	B. Technology-Based Effluent Limitations	F-22
	1. Scope and Authority	F-22
	2. Applicable Technology-Based Effluent Limitations	F-23
	C. Water Quality-Based Effluent Limitations (WQBELs)	F-24
	1. Scope and Authority	F-24
	2. Applicable Beneficial Uses and Water Quality Criteria and Objectives	F-24
	3. Determining the Need for WQBELs	F-26
	4. WQBEL Calculations	F-43
	5. Whole Effluent Toxicity (WET)	F-47
	D. Final Effluent Limitation Considerations	F-49
	1. Mass-based Effluent Limitations	F-49
	2. Averaging Periods for Effluent Limitations	F-49
	3. Satisfaction of Anti-Backsliding Requirements	F-49
	4. Antidegradation Policies	F-52
	5. Stringency of Requirements for Individual Pollutants	F-56
	E. Interim Effluent Limitations	F-58
	F. Land Discharge Specifications	F-60
	G. Recycling Specifications	F-62
V.	Rationale for Receiving Water Limitations	F-63
	A. Surface Water	F-63
	B. Groundwater	F-70
VI.	Rationale for Provisions	F-75
	A. Standard Provisions	F-75
	B. Special Provisions	F-76
	1. Reopener Provisions	F-76
	2. Special Studies and Additional Monitoring Requirements	F-78
	3. Best Management Practices and Pollution Prevention	F-78
	4. Construction, Operation, and Maintenance Specifications	F-79

5. Special Provisions for POTWs	F-81
6. Other Special Provisions.....	F-82
7. Compliance Schedules	F-82
VII. Rationale for Monitoring and Reporting Requirements	F-86
A. Influent Monitoring	F-86
B. Effluent Monitoring	F-87
C. Receiving Water Monitoring	F-87
1. Surface Water	F-87
2. Groundwater	F-88
D. Whole Effluent Toxicity Testing Requirements	F-90
E. Other Monitoring Requirements	F-92
VIII. Public Participation	F-94
A. Notification of Interested Persons	F-94
B. Written Comments	F-94
C. Public Hearing	F-95
D. Reconsideration of Waste Discharge Requirements.....	F-95
E. Information and Copying	F-95
F. Register of Interested Persons	F-96
G. Additional Information	F-96

Tables

Table F-1. Facility Information	F-3
Table F-2. Historic Effluent Limitations	F-6
Table F-3. Basin Plan Beneficial Uses.....	F-11
Table F-4. 303 (d) List for San Joaquin River (in Delta Waterways, southern portion)	F-18
Table F-5. 303 (d) List for Delta Waterways (southern portion)	F-18
Table F-6. Summary of Technology-based Effluent Limitations	F-23
Table F-7. Summary of Criteria for CTR Hardness-dependent Metals	F-26
Table F-8. Salinity Water Quality Criteria/Objectives	F-31
Table F-9. Summary of Water Quality-Based Effluent Limitations.....	F-45
Table F-10. Chronic Whole Effluent Toxicity Testing Results – Test of Significant Toxicity at the IWC (100 Percent Effluent).....	F-47
Table F-11. Summary of Final Effluent Limitations	F-56
Table F-12. Calendar Annual Average TDS concentrations applied to LAAs	F-62
Table F-13. Receiving Water Limitations Review	F-68
Table F-14. Phase 1 Delta Mercury Control Program.....	F-84
Table F-15. Phase 2 Delta Mercury Control Program.....	F-85
Table F-16. Summary of Monitoring Changes	F-90

ATTACHMENT F – FACT SHEET

As described in section II.C of this Order, the Central Valley Water Board incorporates this Fact Sheet as findings of the Central Valley Water Board supporting the issuance of this Order. This Fact Sheet discusses the legal requirements and technical rationale that serve as the basis for the requirements of this Order.

This Order has been prepared under a standardized format to accommodate a broad range of discharge requirements for Dischargers in California. Only those sections or subsections of this Order that are specifically identified as “not applicable” have been determined not to apply to this Discharger. Sections or subsections of this Order not specifically identified as “not applicable” are fully applicable to this Discharger.

I. PERMIT INFORMATION

The following table summarizes administrative information related to the Facility.

Table F-1. Facility Information

Waste Discharge ID:	5B390104001
CIWQS Facility Place ID:	239343
Discharger:	City of Manteca
Name of Facility:	Wastewater Quality Control Facility
Facility Address:	2450 West Yosemite Avenue
Facility City, State Zip:	Manteca, CA 95337
Facility County:	San Joaquin
Facility Contact, Title and Phone Number:	Heather Grove, Wastewater Resources Regulations Manager, (209) 456-8473
Authorized Person to Sign and Submit Reports:	Dustin Valiquette, Wastewater Operations Manager, (209) 456-8486
Mailing Address:	Same as Facility Address
Billing Address:	Same as Facility Address
Type of Facility:	POTW
Major or Minor Facility:	Major
Threat to Water Quality:	1
Complexity:	A
Pretreatment Program:	Yes
Recycling Requirements:	Producer
Facility Permitted Flow:	Existing Facility – 9.87 million gallons per day (MGD) Upgraded Facility – 17.5 MGD
Facility Design Flow:	Existing Facility – 9.87 million gallons per day (MGD) Upgraded Facility (Phase IV Stage 1) 12.87 MGD

	Upgraded Facility (Phase IV Stage 2 Complete)– 17.5 MGD
Watershed:	Sacramento-San Joaquin Delta
Receiving Water:	San Joaquin River
Receiving Water Type:	Estuary

- A.** The City of Manteca (hereinafter Discharger) is the owner and operator of the Wastewater Quality Control Facility (hereinafter Facility), a Publicly-Owned Treatment Works (POTW).

For the purposes of this Order, references to the “discharger” or “permittee” in applicable federal and state laws, regulations, plans, or policy are held to be equivalent to references to the Discharger herein.

- B.** The Facility discharges wastewater to the San Joaquin River, a water of the United States, within the Sacramento-San Joaquin Delta. The Discharger was previously regulated by Order R5-2021-0003 and National Pollutant Discharge Elimination System (NPDES) Permit No. CA0081558 adopted on 18 February 2021 and expires on 31 March 2026. Attachment B provides a map of the area around the Facility. Attachment C provides a flow schematic of the Facility.
- C.** When applicable, state law requires dischargers to file a petition with the State Water Board, Division of Water Rights and receive approval for any change in the point of discharge, place of use, or purpose of use of treated wastewater that decreases the flow in any portion of a watercourse. The State Water Board retains separate jurisdictional authority to enforce any applicable requirements under Water Code section 1211. This is not an NPDES permit requirement.
- D.** The Discharger filed a Report of Waste Discharge (ROWD) and submitted an application for reissuance of its waste discharge requirements (WDRs) and NPDES permit on 25 March 2025. Supplemental information was requested on 11 December 2025 and received on 15 December 2025. The application was deemed complete on 15 January 2026. A site visit was conducted on 29 January 2026, to observe operations and collect additional data to develop permit limitations and requirements for waste discharge.
- E.** Regulations at 40 C.F.R. section 122.46 limit the duration of NPDES permits to a fixed term not to exceed five years. Accordingly, Table 3 of this Order limits the duration of the discharge authorization. Under 40 C.F.R. section 122.6(d), States authorized to administer the NPDES program may administratively continue State-issued permits beyond their expiration dates until the effective date of the new permits, if State law allows it. Pursuant to California Code of Regulations (CCR), title 23, section 2235.4, the terms and conditions of an expired permit are automatically continued pending reissuance of the permit if the Discharger complies with all federal NPDES requirements for continuation of expired permits.

II. FACILITY DESCRIPTION

The Discharger provides sewerage service for commercial and residential uses for the community of Manteca, portions of the City of Lathrop, and the unincorporated communities of Oakwood Shores and Raymus Village and serves a population of approximately 110,050. The design daily average flow capacity of the Facility is 9.87 MGD.

A. Description of Wastewater and Biosolids Treatment and Controls

The Facility has a design average dry weather flow capacity of 9.87 MGD and its treatment process is divided into two parallel treatment systems, the north and south treatment systems. Primary treatment is identical in both systems and consists of mechanical screening, aerated grit removal, and primary sedimentation. The secondary treatment processes for both treatment systems are the same, consisting of conventional activated sludge, including nitrification-denitrification, followed by secondary sedimentation.

Undisinfected secondary effluent is either stored for agricultural use in a 15-million-gallon Secondary Effluent Storage Pond or blended with treated food processing wastewater from Eckert Cold Storage (a processor of vegetables such as cabbage) and applied directly to agricultural fields. The agricultural fields are used to grow crops for dairy feed totaling approximately 167 acres surrounding the Facility. The land application area is approximately 120 acres and consists of 10 fields located on land owned by the Discharger (Fields 2 through 11 – Field 10 was sold in mid-2018).

Tailwater from the irrigation fields percolates into the soil or is recirculated into the irrigation system. Tailwater from Fields 2, 4, and a small portion of 5, is collected in a sump and pumped back to the irrigation supply system. Most of Field 5 is currently used as a storm water drainage basin. Tailwater from Field 3 drains to a sump and pumped into the pond for irrigation. Tailwater from Fields 6 and 9E percolates into the soil. Tailwater from Field 9W drains to adjacent unused land that does not contain an outlet.

Secondary effluent in excess of crop demands undergoes tertiary treatment through rapid mixing, flocculation, cloth media filtration, and ultraviolet (UV) disinfection. The disinfected tertiary recycled water is pumped from the Facility to its Truck Fill Station, located at the entrance of the Facility. The Truck Fill Station provides access for construction vehicles to receive recycled water for construction. The Discharger also has one recycled water user, the Great Wolf Lodge where water is sent for landscape irrigation. Remaining disinfected tertiary level treated effluent is discharged year-round to the San Joaquin River through a 36-inch diameter pipe.

Sludge removed from primary sedimentation is pumped directly to anaerobic digesters while sludge from secondary sedimentation is thickened by dissolved air flotation and then pumped to anaerobic digesters. After digestion, the treated sludge is dewatered by centrifuge. Dried biosolids, grit, and screenings are hauled offsite for land application, composting, or sent to a landfill for disposal by Synagro.

The City has an approved EPA pretreatment program. The municipal wastewater collection system consists of two main lines servicing the City of Manteca that includes 249 miles of sewer mains with 18 pump stations, and another line servicing the City of Lathrop that is connected by 27 miles of sewer mains. The collection systems are regulated under State Water Resources Control Board (State Water Board) Order WQ 2022-0103-DWQ. A separate industrial line accepts food processing wastewater seasonally from Eckert Cold Storage from about May through November. Eckert Cold Storage processes frozen vegetables (e.g., cabbage and a variety of peppers), and discharges primarily wastewater from the cutting and washing of these vegetables. At times, the food processing wastewater is mixed with wastewaters from clean-up of the processing equipment, freezer defrost waters, and cooling towers. The food processing wastewater is stored and aerated in the lined Food Receiving and Processing Wastewater Pond, and then applied to agricultural fields when needed. Use of land disposal onto agricultural fields is being phased out as the Discharger is using more of its land for commercial development.

B. Discharge Points and Receiving Waters

1. The Facility is located in section 4, T2S, R6E, MDB&M, as shown in Attachment B, a part of this Order.
2. Treated municipal wastewater is discharged at Discharge Point 001 to San Joaquin River, a water of the United States within the Sacramento-San Joaquin Delta at a point latitude 37° 46' 45" N and longitude 121° 18' 0" W.

C. Summary of Existing Requirements and Self-Monitoring Report (SMR) Data

Effluent limitations contained in Order R5-2021-0003 for discharges from Discharge Point 001 (Monitoring Location EFF-001) and representative monitoring data from the term of Order R5-2021-0003 are as follows:

Table F-2. Historic Effluent Limitations

Parameter	Units	Historic Effluent Limitations	Highest Average Monthly Discharge	Highest Average Weekly Discharge	Highest Daily Discharge
Acute Whole Effluent Toxicity	% Survival	Instantaneous Min 70 3-day Median 90	--	--	95
Ammonia Nitrogen, Total (as N) (1 April – 30 November)	mg/L	AMEL 2.0 AWEL 4.2	2.6	--	7.6
Ammonia Nitrogen, Total (as N) (1 April – 30 November)	lbs/day	AMEL 160 AWEL 340	109	--	354

Parameter	Units	Historic Effluent Limitations	Highest Average Monthly Discharge	Highest Average Weekly Discharge	Highest Daily Discharge
Ammonia Nitrogen, Total (as N) (1 December – 31 March)	mg/L	AMEL 2.5 AWEL 6.2	3.7	--	4.2
Ammonia Nitrogen, Total (as N) (1 December – 31 March)	lbs/day	AMEL 200 AWEL 510	281	--	358
Biochemical Oxygen Demand (BOD ₅), 5-day @ 20°Celsius	mg/L	AMEL 10 AWEL 15	6	7	15
BOD ₅	% Removal	Average Monthly Min 85	--	--	96.5
Chlorpyrifos	µg/L	SAMEL ≤ 1.0 SAWEL ≤ 1.0	Not Detected (ND)	ND	--
Diazinon	µg/L	SAMEL ≤ 1.0 SAWEL ≤ 1.0	ND	ND	--
Electrical Conductivity @ 25°C	µmhos/cm	Annual Average 1,000	--	--	838
Mercury, Total Effective Until 30 December 2030	grams/year	Annual Total Max Loading 90	--	--	21
Methylmercury Effective 31 December 2030	grams/year	Annual Total Max Loading 0.38	--	--	0.15
Nitrate Plus Nitrite (as N)	mg/L	AMEL 10 AWEL 15.3	9	--	11
pH	Standard units	Instantaneous Min 6.5 Instantaneous Max 8.5	--	--	6.5 – 7.7
Temperature	°F	Instantaneous Max Differential 20	--	--	17.5

Parameter	Units	Historic Effluent Limitations	Highest Average Monthly Discharge	Highest Average Weekly Discharge	Highest Daily Discharge
Total Coliform Organisms	MPN/100 mL	7-day median 2.2 Once in 30-days 23 Any time 240	170	49	920
Total Suspended Solids (TSS)	mg/L	AMEL 10 AWEL 15	2.2	2.5	--
TSS	% Removal	Average Monthly Min 85	--	--	96

Table F-2 Notes:

1. Mass-based effluent limitations for ammonia are based on a design average daily discharge flow of 9.87 MGD.
2. **Acute Whole Effluent Toxicity.** The highest daily discharge for acute toxicity is provided as the minimum daily discharge.
3. **Percent removal.** The highest average monthly discharge for BOD₅ and TSS is provided as the minimum average monthly discharge.
4. **Diazinon and Chlorpyrifos.** Effluent limitations for diazinon and chlorpyrifos are based on the concentrations that shall not exceed the sum of one (1.0) as identified below:
 - i. **Average Monthly Effluent Limitation (AMEL)**

$$S_{AMEL} = CD_{M-avg}/0.079 + CC_{M-avg}/0.012 \leq 1.0$$

CD M-AVG = average monthly diazinon effluent concentration in µg/L
CC M-AVG = average monthly chlorpyrifos effluent concentration in µg/L.
 - ii. **Average Weekly Effluent Limitation (AWEL)**

$$S_{AWEL} = CD_{W-avg}/0.14 + CC_{W-avg}/0.021 \leq 1.0$$

CD W-AVG = average weekly diazinon effluent concentration in µg/L.
CC W-AVG = average weekly chlorpyrifos effluent concentration in µg/L.
5. **Electrical Conductivity.** The highest annual average for electrical conductivity is provided as the highest daily discharge.
6. **Mercury.** The effluent limitation for mercury is an interim effluent limitation based on the calendar year annual mercury load that applies in lieu of the final effluent limitation for methylmercury. The highest daily discharge for mercury is provided as the maximum annual total loading.
7. **Methylmercury.** The effluent limitation for methylmercury is based on the calendar year annual methylmercury load in accordance with the Delta Mercury Control Program, effective 31 December 2030. The highest daily discharge for methylmercury is provided as the maximum annual total loading.

8. **pH.** Highest daily discharge is provided as a range from daily minimum to daily maximum.
9. **Temperature.** The temperature effluent limitation is based on the maximum calculated temperature difference between the natural receiving water temperature and the final effluent temperature. The highest daily discharge is provided as the highest calculated difference.
10. **Total Coliform Organisms.** The highest 30-day maximum for total coliform is provided as the highest average monthly discharge. The highest 7-day median for total coliform is provided as the highest average weekly discharge. The instantaneous maximum for total coliform is provided as the highest daily discharge.

D. Compliance Summary

1. The Central Valley Water Board issued Administrative and Civil Liability (ACL) Complaint R5-2024-0516 on 27 June 2024, which proposed to assess a civil liability of \$12,000 against the Discharger for effluent violations for ammonia (2 violations), temperature (5 violations), total coliform (4 violations) under Order R5-2021-0003. The Discharger paid the mandatory minimum penalty of \$12,000.
2. The Central Valley Water Board issued ACL Complaint R5-2025-0512 on 13 May 2025, which proposed to assess a civil liability of \$12,000 against the Discharger for effluent violations for ammonia (2 violations), total coliform (4 violations) under Order R5-2021-0003. The Discharger paid the mandatory minimum penalty of \$12,000.

E. Planned Changes

1. **Facility Upgrades.** The Discharger is in the process of completing Phase IV improvements to expand the discharge capacity of the Facility from 9.87 MGD to 17.5 MGD. The improvements will increase the discharge capacity from 9.87 MGD to 12.87 MGD during Stage 1 and from 12.87 MGD to 17.5 MGD during Stage 2. The Discharger prepared and submitted for public review a Draft Environmental Impact Report (DEIR) in compliance with the California Environmental Quality Act (CEQA) that addressed the expansion project. The increased discharge will be primarily for effluent discharges to the San Joaquin River because the Discharger determined that it's impracticable to acquire additional agricultural fields; however, the Discharger is seeking to expand its Title 22 recycled water program (e.g., baseball field, parks). As part of the DEIR, the Discharger performed extensive hydrodynamic and thermal modeling to determine the effects of the increased discharge flow to the San Joaquin River and to the Sacramento-San Joaquin Delta downstream of the discharge. The modeling of the thermal plume, completed in 2008, suggested that the increase in discharge to 17.5 MGD would potentially cause an exceedance of provisions of the Thermal Plan; however, a comparison of recent discharge and river temperatures shows that this is no longer a concern. As such, the planned projects for Stages 1 and 2 do not include capital projects for effluent cooling facilities; the need for such facilities will be re-evaluated at a future time.

Improvements may include new influent flow meters, two new influent pump, two new aerated grit tanks, two new sedimentation basins constructed at the south-side plant, adding two membrane bioreactors, two additional digesters, one additional centrifuge, and four new rotating drum thickeners. The final treatment units may vary based on site conditions, final design, changes in design standards, advancements in technology, changes in regulations, commercial availability, and the Discharger's financial capabilities. The Discharger is required to meet the requirements contained in WDR section VI.C.6.c before increasing the discharge capacity to 12.87 MGD and WDR section IV.C.1.h before increasing the discharge capacity to 17.5 MGD. The Discharger plans to complete Stage 1 (12.87 MGD) improvements during the term of this Order.

2. **Regionalization, Reclamation, and Recycling.** The Facility is currently a regional treatment facility. In 1986 the Facility began treating a portion of the City of Lathrop's municipal sewage, who is entitled to 14.7% of the Facility's treatment capacity including the planned facility expansion. Furthermore, in the 1970's, the Facility began treating municipal sewage from Raymus Village, a San Joaquin County community. Additionally, the Discharger continues ongoing negotiations with the Oakwood Shores residential development and the City of Ripon regarding acceptance and treatment of their municipal sewage; however, discussions are preliminary and there is not a final proposal at this time. The Discharger currently reclaims wastewater by irrigating a total of 167 acres of agricultural fields that grow primarily alfalfa used for fodder. Based upon the Discharger's investigation for additional recycled water use, additional agricultural field acreage is not available within the vicinity of the Facility for additional wastewater reclamation opportunities. However, the Discharger evaluated urban water recycling opportunities within the City of Manteca in their 2007 City of Manteca Recycled Water Master Plan (Recycled Water Master Plan). The Recycled Water Master Plan identified 134 sites comprising 817 acres within the City of Manteca as candidates for receiving recycled water that could potentially use 3,700 acre-feet per year of recycled water. The Recycled Water Master Plan also proposes expansion of its recycled water program that includes construction of a backbone delivery network to deliver recycled water to the municipal golf course, the regional softball complex, major commercial centers along State Route 120, and to the largest community parks in South Manteca.

III. APPLICABLE PLANS, POLICIES, AND REGULATIONS

The requirements contained in this Order are based on the requirements and authorities described in this section.

A. Legal Authorities

This Order serves as WDRs pursuant to article 4, chapter 4, division 7 of the California Water Code (commencing with section 13260). This Order is also issued

pursuant to section 402 of the federal Clean Water Act (CWA) and implementing regulations adopted by the U.S. EPA and chapter 5.5, division 7 of the Water Code (commencing with section 13370). It shall serve as an NPDES permit for point source discharges from this Facility to surface waters.

B. California Environmental Quality Act (CEQA)

Under Water Code section 13389, this action to adopt an NPDES permit is exempt from the provisions of Chapter 3 of CEQA, (commencing with section 21100) of Division 13 of the Public Resources Code. Additionally, the adoption of land discharge requirements for the Facility constitutes permitting of an existing facility that is categorically exempt from the provisions of CEQA pursuant to CCR, title 14, section 15301.

C. State and Federal Laws, Regulations, Policies, and Plans

1. **Water Quality Control Plan.** Requirements of this Order specifically implement the applicable Water Quality Control Plans.

- a. **Basin Plan.** The Central Valley Water Board adopted a Water Quality Control Plan for the Sacramento River and San Joaquin River Basins, Fifth Edition, May 2018 (hereinafter Basin Plan) that designates beneficial uses, establishes water quality objectives, and contains implementation programs and policies to achieve those objectives for all waters addressed through the plan. Requirements in this Order implement the Basin Plan. In addition, the Basin Plan implements State Water Board Resolution 88-63, which established state policy that all waters, with certain exceptions, should be considered suitable or potentially suitable for municipal or domestic supply. Beneficial uses applicable to the San Joaquin River within the Sacramento – San Joaquin Delta are as follows:

Table F-3. Basin Plan Beneficial Uses

Discharge Point	Receiving Water Name	Beneficial Use(s)
001	San Joaquin River	Existing: Municipal and domestic water supply (MUN); agricultural supply, including stock watering (AGR); industrial process supply (PROC); industrial service supply (IND); water contact recreation (REC-1); noncontact water recreation (REC-2); warm freshwater habitat (WARM); cold freshwater habitat (COLD); warm and cold migration of aquatic organisms (MIGR); warm spawning, reproduction, and/or early development (SPWN); wildlife habitat (WILD); and navigation (NAV).

Discharge Point	Receiving Water Name	Beneficial Use(s)
--	Groundwater	Existing: MUN, AGR, IND, PROC

- b. **Water Quality Control Plan for Inland Surface Waters, Enclosed Bays, and Estuaries of California.** The Water Quality Control Plan for Inland Surface Waters, Enclosed Bays, and Estuaries of California (ISWEBE Plan) was adopted by the State Water Resources Control Board (State Water Board) on 1 December 2020, under authority provided by Water Code sections 13140 and 13170. Except as otherwise indicated, this ISWEBE Plan establishes provisions for water quality and sediment quality that apply to all inland surface waters, enclosed bays, and estuaries and coastal lagoons of the state, including both waters of the United States and surface waters of the state. The State Water Board rescinded the ISWEBE Plan on 5 October 2021 in Resolution No. 2021-0044. The portions of the ISWEBE Plan, including the Toxicity Provisions, remain in effect as state policy for water quality control.
- c. **Statewide Toxicity Provisions.** On December 1, 2020, the State Water Board adopted State Policy for Water Quality Control: Toxicity Provisions (Toxicity Provisions) which established statewide numeric water quality objectives for both acute and chronic toxicity, using the TST, and a program of implementation to control toxicity. On October 5, 2021, the State Water Board adopted a resolution confirming that the Toxicity Provisions were adopted as a State Policy for Water Quality Control, for all inland surface waters, enclosed bays, estuaries, and coastal lagoons of the state, regardless of their status as waters of the United States. The Toxicity Provisions establish a uniform regulatory approach to provide consistent protection of aquatic life beneficial uses and protect aquatic habitats and life from the effects of known and unknown toxicants. The Toxicity Provisions were approved by OAL on April 25, 2022, and by U.S. EPA on May 1, 2023.

On December 14, 2023, the State Water Board applied for U.S. EPA Region IX review and approval of a limited-use alternative test procedure (ATP), for the use of one-effluent concentration when conducting whole effluent toxicity (WET) testing, pursuant to 40 Code of Federal Regulations section 136.5 (Aug. 28, 2017). The application is specific to acute or chronic WET tests in Table 1 of the application when using the Test of Significant Toxicity (TST) statistical approach (U.S. EPA, 2010) for analyzing the data. The application is being sought for all dischargers or facilities in the State of California and their associated laboratories. The ATP application is still pending with U.S. EPA.

The use of the TST has been the subject of litigation. In December 2024, the Second District Court of Appeal upheld the use of the TST in an

NPDES permit in the case Camarillo Sanitary District v. California Regional Water Quality Control Board - Los Angeles Region.

A separate legal challenge to the State Water Board's adoption of the Toxicity Provisions originated in Fresno County Superior Court on July 18, 2022, through a petition for writ of mandate filed by Camarillo Sanitary District, City of Simi Valley, City of Thousand Oaks, Central Valley Clean Water Association, and Clean Water SoCal (formerly known as Southern California Alliance of Publicly Owned Treatment Works) (Petitioners). One of the claims was that the Toxicity Provisions was inconsistent with the Clean Water Act. On October 9, 2023, the superior court denied the petition in its entirety.

On December 19, 2023, three of the Petitioners filed a notice of appeal of the Fresno Superior Court's decision upholding the Toxicity Provisions. On August 5, 2025, the Fifth District Court of Appeal issued a published opinion holding that the TST statistical approach, which is an integral component of the Toxicity Provisions, cannot be utilized in NPDES permitting to evaluate WET data because the TST is not an approved method under 40 Code of Federal Regulations Part 136. The Court of Appeal did not, however, disturb the Toxicity Provisions' use of the TST as a part of its water quality objectives. The State Water Board prevailed on all other claims in the litigation. The Court of Appeal's decision became final on September 4, 2025.

On September 15, 2025, the State Water Board filed a petition for review of the Fifth Circuit Court of Appeal's decision with the California Supreme Court. On November 12, 2025, the California Supreme Court granted review. The issues to be briefed and argued are limited to the issues raised in the State Water Board's petition for review.

Pending the California Supreme Court's review, the opinion of the Fifth Circuit Court of Appeal is not binding on the Water Boards. However, the opinion may be cited, not only for its persuasive value, but also for the limited purpose of establishing the existence of a conflict in authority.

In accordance with Water Code sections 13146 and 13247, the Regional Board must fully implement the water quality objectives and their implementation procedures in the Toxicity Provisions. The numeric water quality objectives for chronic and acute toxicity established by the Toxicity Provisions, which are based on the TST, were approved by U.S. EPA and remain in effect. As such, the numeric water quality objectives continue to serve as the applicable federal water quality standards in California.

The Water Boards must also continue to comply with federal Clean Water Act NPDES regulations for determining reasonable potential and establishing applicable water quality-based effluent limitations (WQBELs).

NPDES regulations (40 CFR § 122.44(d)(1)(vii)(A)) require that all WQBELs be derived from and comply with all applicable water quality standards. Moreover, although the Toxicity Provisions left in place narrative water quality objectives for aquatic toxicity in regional water board water quality control plans (basin plans), the Toxicity Provisions did supersede basin plan provisions and portions of the Policy for Implementation of Toxics Standards for Inland Surface Waters, Enclosed Bays, and Estuaries of California (SIP) for implementing narrative water quality objectives. As such, there are currently no basin plan or SIP procedures in effect for implementing narrative water quality objectives to determine reasonable potential as required by 40 CFR § 122.44(d)(1)(ii). As a result, the Regional Board must fully implement all of the Toxicity Provisions.

- d. **Bay-Delta Plan.** The Water Quality Control Plan for the San Francisco Bay/Sacramento-San Joaquin Delta Estuary (Bay-Delta Plan) was adopted in May 1995 by the State Water Board superseding the 1991 Bay-Delta Plan. The Bay-Delta Plan identifies the beneficial uses of the estuary and includes objectives for flow, salinity, and endangered species protection.

The State Water Board adopted Decision 1641 (D-1641) on 29 December 1999 and revised on 15 March 2000. D-1641 implements flow objectives for the Bay-Delta Estuary, approves a petition to change points of diversion of the Central Valley Project and the State Water Project in the Southern Delta, and approves a petition to change places of use and purposes of use of the Central Valley Project. The water quality objectives of the Bay-Delta Plan are implemented as part of this Order.

- e. **Thermal Plan.** The State Water Board adopted the Water Quality Control Plan for Control of Temperature in the Coastal and Interstate Waters and Enclosed Bays and Estuaries of California (Thermal Plan) on 7 January 1971 and amended this plan on 18 September 1975. This plan contains temperature objectives for surface waters. For the purposes of the Thermal Plan, the Discharger is considered to be an Existing Discharger of Elevated Temperature Waste to an Estuary, as defined in the Thermal Plan. Requirements of this Order implement the Thermal Plan.
- f. **Sediment Quality.** The State Water Board adopted the Water Quality Control Plan for Enclosed Bays and Estuaries – Part 1, Sediment Quality on 16 September 2008, and it became effective on 25 August 2009. This plan supersedes other narrative sediment quality objectives and establishes new sediment quality objectives and related implementation provisions for specifically defined sediments in most bays and estuaries. Requirements of this Order implement sediment quality objectives of this Plan.

2. **National Toxics Rule (NTR) and California Toxics Rule (CTR).** U.S. EPA adopted the NTR on 22 December 1992, and later amended it on 4 May 1995 and 9 November 1999. About forty criteria in the NTR applied in California. On 18 May 2000, U.S. EPA adopted the CTR. The CTR promulgated new toxics criteria for California and, in addition, incorporated the previously adopted NTR criteria that were applicable in the state. The CTR was amended on 13 February 2001. These rules contain federal water quality criteria for priority pollutants.
3. **State Implementation Policy.** On 2 March 2000, the State Water Board adopted the Policy for Implementation of Toxics Standards for Inland Surface Waters, Enclosed Bays, and Estuaries of California (State Implementation Policy or SIP). The SIP became effective on 28 April 2000, with respect to the priority pollutant criteria promulgated for California by the U.S. EPA through the NTR and to the priority pollutant objectives established by the Central Valley Water Board in the Basin Plan. The SIP became effective on 18 May 2000, with respect to the priority pollutant criteria promulgated by the U.S. EPA through the CTR. The State Water Board adopted amendments to the SIP on 24 February 2005, that became effective on 13 July 2005. The SIP establishes implementation provisions for priority pollutant criteria and objectives and provisions for chronic toxicity control. Requirements of this Order implement the SIP.
4. **Antidegradation Policy.** Federal regulation 40 C.F.R. section 131.12 requires that the state water quality standards include an antidegradation policy consistent with the federal policy. The State Water Board established California's antidegradation policy in State Water Board Resolution 68-16 ("Statement of Policy with Respect to Maintaining High Quality of Waters in California") (State Anti-Degradation Policy). The State Anti-Degradation Policy is deemed to incorporate the federal antidegradation policy where the federal policy applies under federal law. The State Anti-Degradation Policy requires that existing water quality be maintained unless degradation is justified based on specific findings. The Central Valley Water Board's Basin Plan implements, and incorporates by reference, both the State and federal antidegradation policies. The permitted discharge must be consistent with the antidegradation provision of 40 C.F.R. section 131.12 and the State Anti-Degradation Policy. The Board finds this order is consistent with the Federal and State Water Board antidegradation regulations and policy.
5. **Anti-Backsliding Requirements.** Sections 402(o) and 303(d)(4) of the CWA and federal regulations at 40 C.F.R. section 122.44(l) restrict backsliding in NPDES permits. These anti-backsliding provisions require that effluent limitations in a reissued permit must be as stringent as those in the previous permit, with some exceptions in which limitations may be relaxed.
6. **Domestic Water Quality.** In compliance with Water Code section 106.3, it is the policy of the State of California that every human being has the right to safe, clean, affordable, and accessible water adequate for human consumption,

cooking, and sanitary purposes. This Order promotes that policy by requiring discharges to meet maximum contaminant levels (MCLs) designed to protect human health and ensure that water is safe for domestic use.

7. **Endangered Species Act Requirements.** This Order does not authorize any act that results in the taking of a threatened or endangered species or any act that is now prohibited, or becomes prohibited in the future, under either the California Endangered Species Act (Fish and Game Code, sections 2050 to 2097) or the Federal Endangered Species Act (16 U.S.C.A. sections 1531 to 1544). This Order requires compliance with effluent limits, receiving water limits, and other requirements to protect the beneficial uses of waters of the state. The Discharger is responsible for meeting all requirements of the applicable Endangered Species Act.
8. **Emergency Planning and Community Right to Know Act.** Section 13263.6(a) of the Water Code, requires that “the Regional Water Board shall prescribe effluent limitations as part of the waste discharge requirements of a POTW for all substances that the most recent toxic chemical release data reported to the state emergency response commission pursuant to section 313 of the Emergency Planning and Community Right to Know Act of 1986 (42 U.S.C. Sec. 11023) (EPCRA) indicate as discharged into the POTW, for which the State Water Board or the Regional Water Board has established numeric water quality objectives, and has determined that the discharge is or may be discharged at a level which will cause, have the reasonable potential to cause, or contribute to, an excursion above any numeric water quality objective”.

The most recent toxic chemical data report does not indicate any reportable off-site releases or discharges to the collection system for this Facility. Therefore, a reasonable potential analysis based on information from EPCRA cannot be conducted. Based on information from EPCRA, there is no reasonable potential to cause or contribute to an excursion above any numeric water quality objectives included within the Basin Plan or in any State Water Board plan, so no effluent limitations are included in this permit pursuant to Water Code section 13263.6(a).

However, as detailed elsewhere in this Order, available effluent data indicate that there are constituents present in the effluent that have a reasonable potential to cause or contribute to exceedances of water quality standards and require inclusion of effluent limitations based on federal and state laws and regulations.

9. **Storm Water Requirements.** U.S. EPA promulgated federal regulations for storm water on 16 November 1990 in 40 C.F.R. parts 122, 123, and 124. The NPDES Industrial Storm Water Program regulates storm water discharges from wastewater treatment facilities. Wastewater treatment plants are applicable industries under the storm water program and are obligated to comply with the federal regulations. The State Water Resources Control Board Water Quality Order 2014-0057-DWQ, General Permit for Storm Water Discharges Associated

with Industrial Activities (NPDES General Permit No. CAS000001), does not require facilities to obtain coverage if discharges of storm water are regulated under another individual or general NPDES permit adopted by the State Water Board or Regional Water Board (Finding I.B.20). All storm water at the Facility is captured and directed to the Facility headworks for treatment and disposal under this Order. Therefore, coverage under the General Storm Water Permit is not required.

10. **Statewide General Waste Discharge Requirements for Sanitary Sewer Systems.** The State Water Board issued General Waste Discharge Requirements for Sanitary Sewer Systems, Water Quality Order 2006-0003-DWQ (General Order) on 2 May 2006. The State Water Board amended the MRP for the General Order through Order WQ 2013-0058-EXEC on 6 August 2013. The State Water Board renewed the General Order and adopted Order 2022-0103-DWQ on 6 December 2022 and became effective 5 June 2023. The General Order requires public agencies that own or operate sanitary sewer systems with greater than 1 mile of pipes or sewer lines to enroll for coverage under the General Order. The General Order requires agencies to develop sanitary sewer management plans (SSMPs) and report all sanitary sewer overflows (SSOs), among other requirements and prohibitions.

The Discharger is subject to the requirements of, and must comply with, State Water Board Order 2006-0003-DWQ, Statewide General Waste Discharge Requirements for Sanitary Sewer Systems, as amended by State Water Board Order WQ 2013-0058-EXEC and renewed by State Water Board Order 2022-0103-DWQ and any subsequent order.

11. **Sewage Sludge and Biosolids.** This Order does not authorize any act that results in violation of requirements administered by U.S. EPA to implement 40 C.F.R. Part 503, Standards for the Use or Disposal of Sewage Sludge. These standards regulate the final use or disposal of sewage sludge that is generated during the treatment of domestic sewage in a municipal wastewater treatment facility. The Discharger is responsible for meeting all applicable requirements of 40 C.F.R. Part 503 that are under U.S. EPA's enforcement authority.

12. **Findings on Water Quality Impacts in Disadvantaged or Tribal Communities and Environmental Justice Concerns.** Consistent with Water Code section 13149.2, the Central Valley Water Board has taken into account environmental justice, tribal impact, and racial equity considerations in issuing this Order. The discharges regulated by this Order may impact one or more disadvantaged communities or tribal communities.

The Facility regulated by this Order discharges treated municipal wastewater to the San Joaquin River within the Sacramento – San Joaquin River and is subject to discharge limitations given potential to cause or contribute to exceedances of water quality objectives for certain constituents, including ammonia, dieldrin, nitrate, and nitrite. This Order includes a compliance schedule for attainment of

final effluent limitations for methylmercury, consistent with the Basin Plan. These provisions are carried over from the previous Order, R5-2021-0003, and this Order otherwise remains largely unchanged from R5-2021-003. This Order addresses potential adverse impacts to water quality from the Facility’s discharge by setting prohibitions and limits on the discharge of wastewater, requiring ongoing monitoring and reporting of the discharged wastewater and receiving water, and imposing other specifications on the facility’s wastewater treatment operations.

D. Impaired Water Bodies on CWA 303(d) List

1. Under section 303(d) of the 1972 CWA, states, territories, and authorized tribes are required to develop lists of water quality limited segments. The waters on these lists do not meet water quality standards, even after point sources of pollution have installed the minimum required levels of pollution control technology. On 13 December 2024 U.S. EPA gave partial approval and partial disapproval to California's 2022-2024 section 303(d) List of Water Quality Limited Segments. The Basin Plan references this list of Water Quality Limited Segments (WQLSs), which are defined as "...those sections of lakes, streams, rivers or other fresh water bodies where water quality does not meet (or is not expected to meet) water quality standards even after the application of appropriate limitations for point sources (40 C.F.R. part 130, et seq.)." The Basin Plan also states, "Additional treatment beyond minimum federal standards will be imposed on dischargers to [WQLSs]. Dischargers will be assigned or allocated a maximum allowable load of critical pollutants so that water quality objectives can be met in the segment." The listing for the San Joaquin River includes temperature. The listing for the Sacramento-San Joaquin Delta, which includes the San Joaquin River, includes chlorpyrifos, diazinon, DDT, electrical conductivity, group A pesticides, invasive species, mercury, and toxicity.
2. Total Maximum Daily Loads (TMDLs). Table F-4 and Table F-5, below, identifies the 303(d) listings and any applicable TMDLs. This permit includes WQBELs that are consistent with the assumptions and considerations of the applicable waste load allocations (WLAs) in the chlorpyrifos, diazinon, and mercury TMDLs.

Table F-4. 303 (d) List for San Joaquin River (in Delta Waterways, southern portion)

Pollutant	Potential Sources	TMDL Status
Temperature	Source Unknown	Planned for Completion 2034

Table F-5. 303 (d) List for Delta Waterways (southern portion)

Pollutant	Potential Sources	TMDL Status
Chlorpyrifos	Source Unknown	Adopted and Effective 10 October 2007
Diazinon	Source Unknown	Adopted and Effective 10 October 2007

Pollutant	Potential Sources	TMDL Status
DDT	Source Unknown	Planned for Completion 2027
Electrical Conductivity	Source Unknown	Planned for Completion 2027
Group A Pesticides	Source Unknown	Planned for Completion 2027
Invasive Species	Source Unknown	To Be Determined
Mercury	Agricultural Return Flows, Atmospheric Deposition, Highway/Road/Bridge Runoff, Industrial Point Sources, Municipal Point Sources, Natural Sources, Resource Extraction, Urban Runoff/Storm Sewers	Adopted and Effective 20 October 2011
Toxicity	Source Unknown	To Be Determined

Table F-5 Note:

1. **To Be Determined.** This impairment is not currently prioritized for TMDL development during the permit period. The date of completion for a TMDL will be updated in future permit revisions should the prioritization of this impairment change.
3. The 303(d) listings and TMDLs have been considered in the development of the Order.

E. Other Plans, Polices and Regulations

1. **Title 27.** The discharge authorized herein, and the treatment and storage facilities associated with the discharge of treated municipal wastewater, except for discharges of residual sludge and solid waste, are exempt from the requirements of Title 27, CCR, section 20005 et seq (hereafter Title 27). The exemption, pursuant to Title 27 CCR section 20090(a), is based on the following:
 - a. The waste consists primarily of domestic sewage and treated effluent;
 - b. The waste discharge requirements are consistent with water quality objectives; and
 - c. The treatment and storage facilities described herein are associated with a municipal wastewater treatment plant.

Discharges of wastewater to land, including but not limited to evaporation ponds or percolation ponds, are exempt from the requirements of Title 27, CCR, based on section 20090 et seq. The Facility contains storage facilities and agricultural reuse fields where a determination has been made by the Central Valley Water

Board whether the facilities meet the exemptions from Title 27. These facilities include the Secondary Effluent Equalization Pond (SEEP), Secondary Effluent Storage Pond (SESP), Food Receiving and Processing Wastewater Pond, and the Land Application Areas. The Central Valley Water Board's findings regarding Title 27 exemptions are discussed below.

- d. **Secondary Effluent Equalization Pond (SEEP).** The SEEP is exempt from the requirements of Title 27, pursuant to Title 27 CCR section 20090(a). Provision H.4 of Order No. R5 2004-0028 required the Discharger to construct additional storage facilities to demonstrate adequate storage capacity of treated domestic sewage so the discharge to the San Joaquin River could be ceased during periods of incoming tides. The SEEP was constructed to comply with Provision H.4, and therefore, is a necessary part of the Facility's wastewater treatment system. Secondary effluent may be stored in the SEEP prior to tertiary level treatment and discharge to the San Joaquin River. The SEEP is fully tetra-lined.
- e. **Food Receiving and Processing Wastewater Pond.** The Facility accepts food-processing wastewater from Eckert Cold Storage through a separate influent collection line. The wastewater does not go to the headworks of the Facility. Eckert Cold Storage is a seasonal discharger that processes frozen vegetables, cabbage, and a variety of peppers. Eckert Cold Storage treats the food-processing wastewater by screening, dissolved air flotation system, and pH neutralization before discharging to the Facility. The Facility stores and aerates the treated food processing wastewater in the Food Receiving and Processing Wastewater Pond, which is a tetra-lined pond (sides walls and bottom are lined). The Discharger also provides chemical addition in the pond for odor control and additional treatment.

The wastewater does not need to be managed as hazardous waste, and because the pond is lined, the relatively minimal discharge to groundwater would have little effect to cause to exceed applicable water quality objectives. Thus, the discharge to the pond is in compliance with the applicable water quality control plan. Based on these findings the Food Receiving and Processing Wastewater Pond is exempt from the requirements of Title 27 CCR, pursuant to Title 27 CCR section 20090(b).

- f. **Secondary Effluent Storage Pond (SESP).** The SESP holds only secondary effluent that has been treated at the Facility. The SESP has rip/rap sidings and an unlined bottom. Groundwater monitoring data has not been obtained to determine whether any attenuation beneath SESP has occurred. But based on the monitoring results of the representative samples, the wastewater in the SESP does not need to be managed as hazardous waste.

- g. **Land Application Area.** During the agricultural season (about late April through early October), the Discharger either directly irrigates agricultural fields with the treated food processing wastewater, or blends this treated food processing wastewater with secondary treated municipal effluent before reusing the wastewater on land. Use of reclaimed wastewater for irrigation purposes on agricultural fields, serves to conserve valuable surface water drinking water supplies. The reuse of treated wastewater on agricultural fields is exempt from Title 27 pursuant to Section 20090(h).

IV. RATIONALE FOR EFFLUENT LIMITATIONS AND DISCHARGE SPECIFICATIONS

The CWA requires point source dischargers to control the amount of conventional, non-conventional, and toxic pollutants that are discharged into the waters of the United States. The control of pollutants discharged is established through effluent limitations and other requirements in NPDES permits. There are two principal bases for effluent limitations in the Code of Federal Regulations: 40 C.F.R. section 122.44(a) requires that permits include applicable technology-based limitations and standards; and 40 C.F.R. section 122.44(d) requires that permits include water quality-based effluent limitations to attain and maintain applicable numeric and narrative water quality criteria to protect the beneficial uses of the receiving water.

A. Discharge Prohibitions

1. **Prohibition III.A (No discharge or application of waste other than that described in this Order).** This prohibition is based on Water Code section 13260 that requires filing of a ROWD before discharges can occur. The Discharger submitted a ROWD for the discharges described in this Order; therefore, discharges not described in this Order are prohibited.
2. **Prohibition III.B (No bypasses or overflow of untreated wastewater, except under the conditions at CFR section 122.41(m)(4)).** As stated in section I.G of Attachment D, Standard Provisions, this Order prohibits bypass from any portion of the treatment facility. Federal regulations, 40 C.F.R. section 122.41(m), define “bypass” as the intentional diversion of waste streams from any portion of a treatment facility. This section of the federal regulations, 40 C.F.R. section 122.41(m)(4), prohibits bypass unless it is unavoidable to prevent loss of life, personal injury, or severe property damage. In considering the Regional Water Board’s prohibition of bypasses, the State Water Board adopted a precedential decision, Order No. WQO 2002-0015, which cites the federal regulations, 40 C.F.R. section 122.41(m), as allowing bypass only for essential maintenance to assure efficient operation.
3. **Prohibition III.C (No controllable condition shall create a nuisance).** This prohibition is based on Water Code section 13050 that requires water quality objectives established for the prevention of nuisance within a specific area. The Basin Plan prohibits conditions that create a nuisance

4. **Prohibition III.D (No discharge of hazardous waste).** This prohibition is based on CCR, title 22, section 66261.1 et seq, that prohibits discharge of hazardous waste.
5. **Prohibition III.E (Average Dry Weather Flow).** This prohibition is based on the design average dry weather flow treatment capacity rating for the Facility and ensures the Facility is operated within its treatment capacity.
6. **Prohibition III.F (CV-SALTS).** During Phase I of the Salt Control Program, the Discharger is prohibited from discharging salts at concentrations exceeding the salinity numeric value of 700 $\mu\text{mhos/cm}$ (as a monthly average) unless the Discharger is implementing the Phase I requirements of the Salt Control Program Alternative Permitting Approach (i.e., full participation in the P&O Study). The Discharger is prohibited from discharging nitrate and other forms of nitrogen speciation (e.g., total inorganic nitrogen and total Kjeldahl nitrogen) unless the Discharger is implementing the requirements of the Nitrate Control Program Management Zone Approach.

B. Technology-Based Effluent Limitations

1. Scope and Authority

Section 301(b) of the CWA and implementing U.S. EPA permit regulations at 40 C.F.R. section 122.44 require that permits include conditions meeting applicable technology-based requirements at a minimum, and any more stringent effluent limitations necessary to meet applicable water quality standards. The discharge authorized by this Order must meet minimum federal technology-based requirements based on Secondary Treatment Standards at 40 C.F.R. part 133.

Regulations promulgated in 40 C.F.R. section 125.3(a)(1) require technology-based effluent limitations for municipal Dischargers to be placed in NPDES permits based on Secondary Treatment Standards or Equivalent to Secondary Treatment Standards.

The Federal Water Pollution Control Act Amendments of 1972 (PL 92-500) established the minimum performance requirements for POTWs [defined in section 304(d)(1)]. Section 301(b)(1)(B) of that Act requires that such treatment works must, as a minimum, meet effluent limitations based on secondary treatment as defined by the U.S. EPA Administrator.

Based on this statutory requirement, U.S. EPA developed secondary treatment regulations, which are specified in 40 C.F.R. part 133. These technology-based regulations apply to all municipal wastewater treatment plants and identify the minimum level of effluent quality attainable by secondary treatment in terms of BOD₅, TSS, and pH.

2. Applicable Technology-Based Effluent Limitations

- a. **BOD₅ and TSS.** Federal regulations at 40 C.F.R. part 133, establish the minimum weekly and monthly average level of effluent quality attainable by secondary treatment for BOD₅ and TSS. A daily maximum effluent limitation for BOD₅ and TSS is also included in the Order to ensure that the treatment works are not organically overloaded and operate in accordance with design capabilities. In addition, 40 C.F.R. section 133.102, in describing the minimum level of effluent quality attainable by secondary treatment, states that the 30-day average percent removal shall not be less than 85 percent. This Order contains a limitation requiring an average of 85 percent removal of BOD₅ and TSS over each calendar month. This Order requires Water Quality Based Effluent Limitations (WQBELs) that are equal to or more stringent than the secondary technology-based treatment described in 40 CFR part 133 (See section IV.C.3.c.iv of the Fact Sheet for a discussion on Pathogens which includes WQBELs for BOD₅ and TSS.)
- b. **pH.** The secondary treatment regulations at 40 C.F.R. part 133 also require that pH be maintained between 6.0 and 9.0 standard units. This Order, however, requires more stringent WQBELs for pH to comply with the Basin Plan’s water quality objectives for pH.

**Summary of Technology-based Effluent Limitations
Discharge Point 001**

Table F-6. Summary of Technology-based Effluent Limitations

Parameter	Units	Effluent Limitations
Biochemical Oxygen Demand (BOD ₅) (5- day @ 20°C)	mg/L	AMEL 30 AWEL 45
BOD ₅	% removal	Average Monthly Min 85
pH	Standard units	Instantaneous Min 6.0 Instantaneous Max 9.0
Total Suspended Solids (TSS)	mg/L	AMEL 30 AWEL 45
TSS	% removal	Average Monthly Min 85

Table F-6 Notes:

- 1. Note that more stringent WQBELs for BOD₅, pH, and TSS are applicable and are established as final effluent limitations in this Order (see section IV.C.3.c of this Fact Sheet).

C. Water Quality-Based Effluent Limitations (WQBELs)

1. Scope and Authority

CWA section 301(b) and 40 C.F.R. section 122.44(d) require that permits include limitations more stringent than applicable federal technology-based requirements where necessary to achieve applicable water quality standards. This Order contains requirements, expressed as a technology equivalence requirement, more stringent than secondary treatment requirements that are necessary to meet applicable water quality standards. The rationale for these requirements, which consist of tertiary treatment or equivalent requirements, is discussed in section IV.C.3 of this Fact Sheet.

Section 122.44(d)(1)(i) of 40 C.F.R. requires that permits include effluent limitations for all pollutants that are or may be discharged at levels that have the reasonable potential to cause or contribute to an exceedance of a water quality standard, including numeric and narrative objectives within a standard. Where reasonable potential has been established for a pollutant, but there is no numeric criterion or objective for the pollutant, WQBELs must be established using: (1) U.S. EPA criteria guidance under CWA section 304(a), supplemented where necessary by other relevant information; (2) an indicator parameter for the pollutant of concern; or (3) a calculated numeric water quality criterion, such as a proposed state criterion or policy interpreting the state's narrative criterion, supplemented with other relevant information, as provided in section 122.44(d)(1)(vi).

The process for determining reasonable potential and calculating WQBELs when necessary is intended to protect the designated beneficial uses of the receiving water as specified in the Basin Plan and achieve applicable water quality objectives and criteria that are contained in other state plans and policies, or any applicable water quality criteria contained in the CTR and NTR.

Finally, 40 C.F.R. section 122(d)(1)(vii) requires effluent limits to be developed consistent with any available WLAs developed and approved for the discharge.

2. Applicable Beneficial Uses and Water Quality Criteria and Objectives

The Basin Plan designates beneficial uses, establishes water quality objectives, and contains implementation programs and policies to achieve those objectives for all waters addressed through the plan. In addition, the Basin Plan implements State Water Board Resolution No. 88-63, which established state policy that all waters, with certain exceptions, should be considered suitable or potentially suitable for municipal or domestic supply.

The Basin Plan on page 2-1 states: "Protection and enhancement of existing and potential beneficial uses are primary goals of water quality planning..." and with respect to disposal of wastewaters states that "...disposal of wastewaters is [not] a prohibited use of waters of the State; it is merely a use which cannot

be satisfied to the detriment of beneficial uses.”

The federal CWA section 101(a)(2), states: “it is the national goal that wherever attainable, an interim goal of water quality which provides for the protection and propagation of fish, shellfish, and wildlife, and for recreation in and on the water be achieved by July 1, 1983.” Federal Regulations, developed to implement the requirements of the CWA, create a rebuttable presumption that all waters be designated as fishable and swimmable. Federal Regulations, 40 CFR sections 131.2 and 131.10, require that all waters of the State regulated to protect the beneficial uses of public water supply, protection and propagation of fish, shellfish and wildlife, recreation in and on the water, agricultural, industrial and other purposes including navigation. 40 C.F.R. section 131.3(e) defines existing beneficial uses as those uses actually attained after 28 November 1975, whether or not they are included in the water quality standards. Federal Regulation, 40 C.F.R. section 131.10 requires that uses be obtained by implementing effluent limitations, requires that all downstream uses be protected and states that in no case shall a state adopt waste transport or waste assimilation as a beneficial use for any waters of the United States.

- a. **Receiving Water and Beneficial Uses.** Refer to III.C.1. above for a complete description of the receiving water and beneficial uses.
- b. **Effluent and Ambient Background Data.** The reasonable potential analysis (RPA), as described in section IV.C.3 of this Fact Sheet, was based on data from April 2022 through March 2025, which includes effluent and ambient background data submitted in SMRs and the ROWD.
- d. **Conversion Factors.** The default U.S. EPA conversion factors contained in Appendix 3 of the SIP were used to convert the applicable dissolved criteria to total criteria. Per the Reopener Provisions of this Order, if the Discharger performs studies to determine site-specific dissolved-to-total metal translators this Order may be reopened to modify the effluent limitations for the applicable inorganic constituents.
- e. **Hardness-Dependent CTR Metals Criteria.** The CTR and the NTR contain water quality criteria for seven metals that vary as a function of hardness. The lower the hardness the lower the water quality criteria. The metals with hardness-dependent criteria include cadmium, copper, chromium III, lead, nickel, silver, and zinc. This Order has established the criteria for hardness-dependent metals based on the hardness of the receiving water (actual ambient hardness) as required by the SIP and the CTR.

The ambient hardness for the San Joaquin River ranges from 32 mg/L to 172 mg/L based on collected ambient data from April 2022 through March 2025. Given the high variability in ambient hardness values, there is no single hardness value that describes the ambient receiving water for all

possible scenarios (e.g., minimum, maximum). Because of this variability, staff has determined that based on the ambient hardness concentrations measured in the receiving water, the Central Valley Water Board has discretion to select ambient hardness values within the range of 32 mg/L (minimum) up to 172 mg/L (maximum).

The Central Valley Water Board finds that the use of the ambient hardness values and associated acute and chronic criteria shown in Table F-7 to conduct the reasonable potential analysis (RPA) and calculate WQBELs, protect beneficial uses under all ambient receiving water conditions and comply with the SIP, CTR, and Basin Plan.

Table F-7. Summary of Criteria for CTR Hardness-dependent Metals

CTR Metals	Ambient Hardness (mg/L)	Acute Criteria (µg/L, total)	Chronic Criteria (µg/L, total)
Copper	91	13	8.6
Chromium III	91	1600	190
Cadmium	78 (acute) 91 (chronic)	4.1	2.3
Lead	82	63	2.5
Nickel	91	430	48
Silver	64	1.9	--
Zinc	91	110	110

Table F-7 Notes:

- Criteria (µg/L total).** Acute and chronic criteria were rounded to two significant figures in accordance with the CTR (40 C.F.R. section 131.38(b)(2)).
- Ambient hardness (mg/L).** Values in Table F-7 represent actual observed receiving water hardness measurements.

3. Determining the Need for WQBELs

Clean Water Act section 301(b)(1)(C) requires effluent limitations necessary to meet water quality standards, and 40 C.F.R. section 122.44(d) requires NPDES permits to include conditions that are necessary to achieve water quality standards established under section 303 of the CWA, including State narrative criteria for water quality. Federal regulations at 40 C.F.R 122.44(d)(1)(i) state, "Limitations must control all pollutants or pollutant parameters (either conventional, nonconventional, or toxic pollutants) which the Director determines are or may be discharged at a level that will cause, have the reasonable potential to cause, or contribute to an excursion above any State water quality standard, including State narrative criteria for water quality." Additionally, 40 C.F.R. section 122(d)(1)(vii) requires effluent limits to be developed consistent with any available WLAs developed and approved for the discharge. The process to determine whether a WQBEL is required as described in 40 C.F.R. section 122.44(d)(1)(i) is referred to as a reasonable

potential analysis or RPA. Central Valley Water Board staff conducted RPAs for nearly 200 constituents, including the 126 U.S. EPA priority toxic pollutants. This section includes details of the RPAs for constituents of concern for the Facility. The entire RPA is included in the administrative record and a summary of the constituents of concern is provided in Attachment G.

For priority pollutants, the SIP dictates the procedures for conducting the RPA. For non-priority pollutants the Central Valley Water Board is not restricted to one particular RPA method; therefore, the RPAs have been conducted based on U.S. EPA guidance considering multiple lines of evidence and the site-specific conditions of the discharge. Ammonia, nitrate plus nitrite, pH, pathogens, temperature, and whole effluent toxicity are not priority pollutants. Due to the site-specific conditions of the discharge, the Central Valley Water Board has used professional judgment in determining the appropriate method for conducting the RPA for these non-priority pollutant parameters based on a qualitative assessment as recommended by U.S. EPA guidance. U.S. EPA's September 2010 NPDES Permit Writer's Manual, page 6-30, states, "State implementation procedures might allow, or even require, a permit writer to determine reasonable potential through a qualitative assessment process without using available facility-specific effluent monitoring data or when such data are not available...A permitting authority might also determine that WQBELs are required for specific pollutants for all facilities that exhibit certain operational or discharge characteristics (e.g., WQBELs for pathogens in all permits for POTWs discharging to contact recreational waters)." U.S. EPA's TSD also recommends that factors other than effluent data should be considered in the RPA, "When determining whether or not a discharge causes, has the reasonable potential to cause, or contributes to an excursion of a numeric or narrative water quality criterion for individual toxicants or for toxicity, the regulatory authority can use a variety of factors and information where facility-specific effluent monitoring data are unavailable. These factors also should be considered with available effluent monitoring data." With regard to POTWs, U.S. EPA recommends that, "POTWs should also be characterized for the possibility of chlorine and ammonia problems." (TSD, p. 50)

a. **Constituents with Total Maximum Daily Load (TMDL).**

40 C.F.R. section 122.44(d)(1)(vii) provides: "When developing water quality-based effluent limits under [section 122.44(d)(1)], the permitting authority shall ensure that: (A) The level of water quality to be achieved by limits on point sources established under this paragraph is derived from, and complies with all applicable water quality standards; and (B) Effluent limits developed to protect a narrative water quality criterion, a numeric water quality criterion, or both, are consistent with the assumptions and requirements of any available WLA for the discharge prepared by the State and approved by U.S. EPA pursuant to [Total Maximum Daily Loads regulations]." U.S. EPA construes 40 C.F.R. section 122.44(d)(1)(vii)(B) to mean that "when WLAs are available, they must be used to translate

water quality standards into NPDES permit limits.” 54 Fed. Reg. 23868, 23879 (June 2, 1989).

San Joaquin River is subject to TMDLs for chlorpyrifos, diazinon, and mercury and WLAs under those TMDLs are available. The Central Valley Water Board developed WQBELs for these pollutants pursuant to 40 C.F.R. section 122.44(d)(1)(vii), which does not require or contemplate a reasonable potential analysis.

i. **Diazinon and Chlorpyrifos.**

- (a) **WQO.** The Central Valley Water Board completed a TMDL for diazinon and chlorpyrifos in the Sacramento – San Joaquin Delta Waterways and amended the Basin Plan to include diazinon and chlorpyrifos WLAs and water quality objectives. The Basin Plan Amendment for the Control of Diazinon and Chlorpyrifos Runoff into the Sacramento – San Joaquin Delta was adopted by the Central Valley Water Board on 23 June 2006 and became effective on 10 October 2007.

The amendment modified Basin Plan Chapter 3 (Water Quality Objectives) to establish site-specific numeric objectives for diazinon and chlorpyrifos in the Delta waterways and identified the requirements to meet the additive formula already in Basin Plan Chapter 4 (Implementation) for the additive toxicity of diazinon and chlorpyrifos.

The amendment states that “The waste load allocations for all NPDES-permitted dischargers...shall not exceed the sum (S) of one (1) as defined below:

$$S = C_d/WQO_d + C_c/WQO_c \leq 1.0$$

Where:

C_d = diazinon concentration in $\mu\text{g/L}$ of point source discharge

C_c = chlorpyrifos concentration in $\mu\text{g/L}$ of point source discharge

WQO_d = acute or chronic diazinon water quality objective in $\mu\text{g/L}$

WQO_c = acute or chronic chlorpyrifos water quality objective in $\mu\text{g/L}$

Available samples collected within the applicable averaging period for the water quality objective will be used to determine compliance with the allocations and loading capacity. For

purposes of calculating the sum (S) above, analytical results that are reported as ‘non-detectable’ concentrations are considered to be zero.”

Appendix 42 of the Diazinon and Chlorpyrifos TMDL lists waterways subject to the TMDL and includes the San Joaquin River.

- (b) **WQBELs.** WQBELs for diazinon and chlorpyrifos are required per the TMDL. This Order includes effluent limits calculated based on the WLAs contained in the TMDL, as follows:

Average Monthly Effluent Limitation (AMEL)

$$S(\text{AMEL}) = C_d (\text{M-avg})/0.079 + C_c (\text{M-avg})/0.012 \leq 1.0$$

Where:

$C_d(\text{M-avg})$ = average monthly diazinon effluent concentration in $\mu\text{g/L}$

$C_c (\text{M-avg})$ = average monthly chlorpyrifos effluent concentration in $\mu\text{g/L}$

Average Weekly Effluent Limitation (AWEL)

$$S(\text{AWEL}) = C_d (\text{W-avg})/0.14 + C_c (\text{W-avg})/0.021 \leq 1.0$$

Where:

$C_d(\text{W-avg})$ = average weekly diazinon effluent concentration in $\mu\text{g/L}$

$C_c (\text{W-avg})$ = average weekly chlorpyrifos effluent concentration in $\mu\text{g/L}$

- (c) **Plant Performance and Attainability.** Chlorpyrifos and diazinon were not detected in the effluent based on six sampling events conducted between April 2022 through March 2025. Furthermore, since these pesticides have been banned for public use, they are not expected to be present in the influent to the Facility. The Central Valley Water Board concludes, therefore, that immediate compliance with these effluent limitations is feasible.

ii. **Mercury**

- (a) **WQO.** The Basin Plan contains fish tissue objectives for all Sacramento-San Joaquin Delta waterways listed in Appendix 43 of the Basin Plan, which states, “...*the average methylmercury concentrations shall not exceed 0.08 and 0.24 mg methylmercury/kg, wet weight, in muscle tissue of trophic level 3 and 4 fish, respectively (150-500 mm total length). The average methylmercury concentrations shall not exceed 0.03 mg methylmercury/kg, wet weight, in whole fish less than 50 mm in length.*” The Delta Mercury Control Program contains aqueous methylmercury WLAs that are calculated to achieve these fish

tissue objectives. Methylmercury reductions are assigned to dischargers with concentrations of methylmercury greater than 0.06 ng/L (the concentration of methylmercury in water to meet the fish tissue objective). The Facility is allocated 0.38 grams/year of methylmercury by 31 December 2030, as listed in Table IV-7B of the Basin Plan.

The CTR contains a human health criterion of 51 ng/L for total mercury for waters from which both water and aquatic organisms are consumed. However, in 40 C.F.R. part 131, U.S. EPA acknowledges that the human health criteria may not be protective of some aquatic or endangered species and that *“...more stringent mercury limits may be determined and implemented through the use of the State’s narrative criterion.”* In the CTR, U.S. EPA reserved the mercury criteria for freshwater and aquatic life and may adopt new criteria at a later date.

- (b) **WQBELs.** The Basin Plan’s Delta Mercury Control Program includes WLAs for POTWs in the Delta, including for the Discharger. This Order contains a final WQBEL for methylmercury based on the WLA. Effective 31 December 2030, the total calendar annual methylmercury load shall not exceed 0.38 grams.
 - (c) **Plant Performance and Attainability.** A compliance schedule in accordance with the State Water Board’s Compliance Schedule Policy and the Delta Mercury Control Program has been established in section VI.C.7.a of this Order. The final WQBELs for methylmercury are effective 31 December 2030.
- b. **Constituents with No Reasonable Potential.** Central Valley Water Board staff conducted reasonable potential analyses for nearly 200 constituents, including the 126 U.S. EPA priority toxic pollutants. All reasonable potential analyses are included in the administrative record and a summary of the constituents of concern is provided in Attachment G. WQBELs are not included in this Order for constituents that do not demonstrate reasonable potential to cause or contribute to an instream excursion of an applicable water quality objective; however, monitoring for those pollutants is established in this Order as required by the SIP. If the results of effluent monitoring demonstrate reasonable potential, this Order may be reopened and modified by adding an appropriate effluent limitation.

Most constituents with no reasonable potential are not discussed in this Order. This section only provides the rationale for the reasonable potential

analyses for the following constituents of concern that were found to have no reasonable potential after assessment of the data:

i. Salinity

- (a) **WQO.** The Basin Plan contains a chemical constituent objective that incorporates state MCLs, contains a narrative objective, and contains numeric water quality objectives for certain specified water bodies for electrical conductivity, total dissolved solids, sulfate, and chloride. The U.S. EPA Ambient Water Quality Criteria for Chloride recommends acute and chronic criteria for the protection of aquatic life. There are no U.S. EPA water quality criteria for the protection of aquatic life for electrical conductivity, total dissolved solids, and sulfate. Additionally, there are no U.S. EPA numeric water quality criteria for the protection of agricultural, livestock, and industrial uses. Numeric values for the protection of these uses are typically based on site specific conditions and evaluations to determine the appropriate constituent threshold necessary to interpret the narrative chemical constituent Basin Plan objective. The Central Valley Water Board must determine the applicable numeric limit to implement the narrative objective for the protection of agricultural supply. The Bay-Delta Plan includes numeric water quality criteria for the protection of agricultural and MUN beneficial uses. Table F-8, below, contains various recommended levels for EC or TDS, sulfate, and chloride.

Table F-8. Salinity Water Quality Criteria/Objectives

Parameters	Bay-Delta Plan	Secondary MCLs (Recommended Level, Upper Level, Short-Term Maximum)	U.S. EPA NAWQC	Maximum Calendar Annual Average Effluent Concentration	Maximum Daily Effluent Concentration
EC (µmhos/cm) or TDS (mg/L)	See table note 6	EC 900, 1,600, 2,200 TDS 500, 1,000, 1,500	N/A	EC 838 TDS 480	EC 930 TDS 524
Sulfate (mg/L)	N/A	250, 500, 600	N/A	31	39
Chloride (mg/L)	N/A	250, 500, 600	860 1-hour / 230 4-day	120	131

Table F-8 Notes:

- 1. **Bay-Delta Plan.** Currently effective electrical conductivity water quality objective is 700 µmhos/cm (April – August) and 1,000 µmhos/cm (September – March),

applied as a 30-day running average of mean daily electrical conductivity. Pending revised electrical conductivity water quality objective is 1,000 umhos/cm (year round), applied as a 30-day running average of mean daily EC.

2. **Agricultural Water Quality Objectives.** Applicable agricultural water quality objectives vary. Procedures for establishing the applicable numeric limitation to implement the narrative chemical constituent objective can be found in the Policy for Application of Water Quality Objectives, section 4.2.2.1.9 of the Basin Plan. However, the Basin Plan does not require improvement over naturally occurring background concentrations. In cases where the natural background concentration of a particular constituent exceeds an applicable water quality objective, the natural background concentration will be considered to comply with the objective.
3. **Secondary MCLs.** Secondary MCLs are for protection of public welfare and are stated as a recommended level, upper level, and a short-term maximum level.
4. **Chloride.** The Secondary MCL for chloride is 250 mg/L, as a recommended level, 500 mg/L as an upper level, and 600 mg/L as a short-term maximum.
5. **Electrical Conductivity or Total Dissolved Solids.** The Secondary MCL for EC is 900 µmhos/cm as a recommended level, 1600 µmhos/cm as an upper level, and 2200 µmhos/cm as a short-term maximum, or when expressed as TDS is 500 mg/L as a recommended level, 1000 mg/L as an upper level, and 1500 mg/L as a short-term maximum.
6. **Sulfate.** The Secondary MCL for sulfate is 250 mg/L as a recommended level, 500 mg/L as an upper level, and 600 mg/L as a short-term maximum.

(b) **RPA Results.**

- (1) **Chloride.** Chloride concentrations in the effluent ranged from 119 mg/L to 131 mg/L. These levels do not exceed the Secondary MCL. Background concentrations in San Joaquin River ranged from 13 mg/L to 103 mg/L based on six samples collected by the Discharger from April 2022 through March 2025.
- (2) **Electrical Conductivity or Total Dissolved Solids.** A review of the Discharger's monitoring reports shows that the effluent EC ranged from 697 µmhos/cm to 930 µmhos/cm. These levels exceed the Secondary MCL. The background receiving water EC ranged from 71 µmhos/cm to 785 µmhos/cm.

The effluent TDS ranged from 375 mg/L to 524 mg/L. These levels exceed the Secondary MCL. The background receiving water TDS ranged from 78 mg/L to 364 mg/L.

For priority pollutants, the SIP dictates the procedures for conducting the RPA. Total Dissolved Solids is not a priority pollutant. Therefore, the Central Valley Water Board is not restricted to one particular RPA method. Due to the site-specific conditions of the discharge, the Central Valley Water Board used best professional judgment in determining the appropriate method for conducting the RPA for this non-priority pollutant constituent.

U.S. EPA's September 2010 NPDES Permit Writer's Manual recommends using a mass-balance approach to determine the expected critical downstream receiving water concentration using a steady-state approach. The downstream receiving water concentration is then compared to the applicable water quality threshold to determine if the discharge has reasonable potential to cause or contribute to an in-stream excursion. This approach allows assimilative capacity and dilution to be factored into the RPA. This U.S. EPA recommended approach has been used to assess the reasonable potential for acetaldehyde in the Facility's effluent to adversely affect the receiving water beneficial uses. The critical downstream receiving water concentration is calculated using the equation below:

$$C_r = (Q_s C_s + Q_d C_d) / (Q_s + Q_d)$$

Where:

Q_s = Critical stream flow

Q_d = Critical effluent flow from discharge flow data
(maximum permitted discharge)

C_s = Critical upstream pollutant concentration

C_d = Critical effluent pollutant concentration

C_r = Critical downstream receiving water pollutant
concentration

For the purposes of conducting the RPA, the critical stream flow (Q_s) has been set to the harmonic mean flow of 26.1 MGD in the San Joaquin River using 15 minute interval data collected from the California Data Exchange Center – Mossdale Bridge (MSD) monitoring station from April 2022

to March 2025 and the critical effluent flow (Q_d) has been set to the permitted flow of 9.87 MGD. The critical effluent pollutant concentration, C_d , has been established as the projected annual average effluent concentration. Calculating a maximum annual average concentration considers variability in the data, per 40 C.F.R. § 122.44(d)(1)(ii).

The projected annual average effluent concentration for EC was determined based on effluent data collected from April 2022 to March 2025 and projected using statistics recommended in the TSD for statistically projecting effluent concentrations (i.e., Table 3-1 of the TSD using the 99 percent probability basis and 99 percent confidence level). The projected annual average effluent concentration (C_d) for EC is 844 $\mu\text{mhos/cm}$ based on an average effluent EC concentration of 815 $\mu\text{mhos/cm}$. The annual average upstream receiving water concentration (C_s) for EC was 411 $\mu\text{mhos/cm}$ based on 78 samples collected from April 2022 through March 2023. Using the equation above, the calculated critical downstream receiving water EC concentration (C_r) is 530 $\mu\text{mhos/cm}$, which is comparable to ambient upstream conditions and does not exceed the Secondary MCL. Therefore, based on this data, the discharge does not have reasonable potential to adversely affect receiving water beneficial uses for EC.

The projected annual average effluent concentration for TDS was determined based on effluent data collected from April 2022 to March 2025 and projected using statistics recommended in the TSD for statistically projecting effluent concentrations (i.e., Table 3-1 of the TSD using the 99 percent probability basis and 99 percent confidence level). The projected annual average effluent concentration (C_d) for TDS is 527 mg/L based on an average effluent TDS concentration of 472 mg/L. The annual average upstream receiving water concentration (C_s) for TDS was 209 mg/L based on seven samples collected from April 2022 through March 2023. Using the equation above, the calculated critical downstream receiving water TDS concentration (C_r) is 296 mg/L, which is comparable to ambient upstream conditions and does not exceed the Secondary MCL. Therefore, based on this data, the discharge does not have reasonable potential to adversely affect receiving water beneficial uses for TDS.

- (3) **Sulfate.** Sulfate concentrations in the effluent ranged from 28 mg/L to 39 mg/L. These levels do not exceed the Secondary MCL. Background concentrations in San Joaquin River ranged from 11 mg/L to 57 mg/L.

(c) **WQBELs.**

As discussed above, the discharge does not have reasonable potential to cause or contribute to an in-stream excursion of water quality objectives for salinity. On 17 January 2020, certain amendments to the Basin Plan incorporating a Program to Control and Permit Salt Discharges to Surface and Groundwater (Salt Control Program) became effective. Other amendments became effective on 2 November 2020 when approved by the U.S. EPA. The Salt Control Program is a three-phased program, with each phase lasting 10 to 15 years. The Basin Plan requires all salt dischargers to comply with the provisions of the program. Two compliance pathways are available for salt dischargers during Phase 1.

The Phase 1 Compliance pathways are: 1) Conservative Salinity Permitting Approach, which utilizes the existing regulatory structure and focuses on source control, conservative salinity limits on the discharge, and limits the use of assimilative capacity and compliance time schedules; and, 2) Alternative Salinity Permitting Approach, which is an alternative approach to compliance through implementation of specific requirements such as participating in the Salinity Prioritization and Optimization Study (P&O) rather than the application of conservative discharge limits.

The Discharger submitted a Notice of Intent for the Salinity Control Program indicating its intent to meet the Alternative Salinity Permitting Approach. This Order requires implementation of a Salinity Evaluation and Minimization Plan, participation in the Salinity P&O Study, and includes a performance-based trigger for EC consistent with the Alternative Salinity Permitting Approach.

- c. **Constituents with Reasonable Potential.** The Central Valley Water Board finds that the discharge has a reasonable potential to cause or contribute to an instream excursion above a water quality standard for ammonia, dieldrin, nitrate plus nitrite, total coliform organisms, pH, and temperature. WQBELs for these constituents are included in this Order. A summary of the RPA is provided in Attachment G, and a detailed discussion of the RPA for each constituent is provided below.

i. **Ammonia**

- (a) **WQO.** The 2013 U.S. EPA National Ambient Water Quality Criteria (NAWQC) for the protection of freshwater aquatic life for total ammonia (2013 Criteria), recommends acute (1-hour average; criteria maximum concentration or CMC) and chronic (30-day average; criteria continuous concentration or CCC) standards based on pH and temperature. U.S. EPA also recommends that no 4-day average concentration should exceed 2.5 times the 30-day CCC. The 2013 Criteria reflects the latest scientific knowledge on the toxicity of ammonia to certain freshwater aquatic life, including toxicity data on sensitive freshwater unionid mussels, non-pulmonary snails, and other freshwater organisms.

The Central Valley Clean Water Association (CVCWA) organized a coordinated effort for POTWs within the Central Valley Region, the Freshwater Mussel Collaborative Study for Wastewater Treatment Plants, to determine how the latest scientific knowledge on the toxicity of ammonia reflected in the 2013 Criteria could be implemented in the Central Valley Region. Through this effort a Criteria Recalculation Report was developed in January 2020 using toxicity studies for the freshwater mussel species present in Central Valley Region waters.

The Criteria Recalculation Report implemented U.S. EPA's Recalculation Procedure utilizing toxicity bioassays conducted on resident mussel species to replace the toxicity data for the eastern mussel species in the national dataset to develop site-specific ammonia criteria for waters within the Central Valley Region, including all surface waters in the Sacramento River, San Joaquin River, and Tulare Lake Basin Plans.

U.S. EPA Office of Science and Technology reviewed and approved the Criteria Recalculation Report with a more conservative approach for utilizing the acute-to-chronic ratio procedure for developing the site-specific chronic criterion. The Central Valley Water Board finds that the site-specific ammonia criteria provided in the January 2020 Criteria Recalculation Report implements the Basin Plan's narrative toxicity objective to protect aquatic life beneficial uses of the receiving water.

Site-specific Criteria for San Joaquin River. The recalculated site-specific criteria developed in the Criteria Recalculation Report for the acute and chronic criteria are presented based on equations that vary according to pH and temperature for situations where freshwater mussels are present and where they are absent. In this case, for the San Joaquin River

freshwater mussels have been assumed to be present. In addition, the recalculated criteria include equations that provide enhanced protection for important salmonid species in the genus *Oncorhynchus*, that can be implemented for receiving waters where salmonid species are present. Because the San Joaquin River has a beneficial use of cold freshwater habitat and the presence of salmonids in the San Joaquin River is well-documented, the criteria equations for waters where salmonids are present were used.

The acute (1-hour average) criterion or CMC was calculated using paired effluent pH and temperature data, collected during the period from April 2022 to March 2025. The most stringent CMCs of 5.6 mg/L (ammonia as N) for 1 April through 30 November and 13.3 mg/L (ammonia as N) for 1 December through 31 March have been implemented in this Order.

The chronic (30-day average) criterion or CCC was calculated using paired effluent pH and temperature data, collected during the period from April 2022 to March 2025. The most stringent 30-day rolling average CCC of 1.5 mg/L (ammonia as N) for 1 April through 30 November and 2.7 mg/L (ammonia as N) for 1 December through 31 March have been implemented in this Order.

The chronic (4-day average) concentration is derived in accordance with the U.S. EPA criterion as 2.5 times the 30-day CCC. Based on the 30-day CCC of 1.5 mg/L (ammonia as N) for 1 April through 30 November, the 4-day average concentration that should not be exceeded is 3.7 mg/L (ammonia as N). Based on the 30-day CCC of 2.7 mg/L (ammonia as N) for 1 December through 31 March, the 4-day average concentration that should not be exceeded is 6.7 mg/L (ammonia as N).

- (b) **RPA Results.** The Facility is a POTW that treats domestic wastewater. Untreated domestic wastewater contains ammonia in concentrations that is harmful to aquatic life and exceed the Basin Plan narrative toxicity objective. The Discharger currently uses nitrification to remove ammonia from the waste stream. Inadequate or incomplete treatment may result in the discharge of ammonia to the receiving stream, which creates the basis for the discharge to have a reasonable potential to cause or contribute to an instream excursion above the site-specific acute and chronic criteria for ammonia provided by the January 2020 Criteria Recalculation Report. Therefore, the Central Valley

Water Board finds the discharge has reasonable potential for ammonia and WQBELs are required.

- (c) **WQBELs.** The Central Valley Water Board calculates WQBELs in accordance with SIP procedures for non-CTR constituents, and ammonia is a non-CTR constituent. The SIP procedure assumes a 4-day averaging period for calculating the long-term average discharge condition (LTA). However, U.S. EPA recommends modifying the procedure for calculating permit limits for ammonia using a 30-day averaging period for the calculation of the LTA corresponding to the 30-day CCC. Therefore, while the LTAs corresponding to the acute and 4-day chronic criteria were calculated according to SIP procedures, the LTA corresponding to the 30-day CCC was calculated assuming a 30-day averaging period. This Order contains seasonal average monthly effluent limitation (AMEL) of 1.9 mg/L and average weekly effluent limitation (AWEL) of 4.0 mg/L from 1 April through 30 November and an AMEL of 2.4 mg/L and AWEL of 6.9 mg/L from 1 December through 31 March for ammonia, based on the site-specific ammonia criteria for San Joaquin River.
- (d) **Plant Performance and Attainability.** Analysis of the effluent data shows that the MEC of 7.6 mg/L from 1 April through 30 November is greater than the seasonal WQBELs and the MEC of 4.2 mg/L from 1 December to 31 March is greater than applicable seasonal AMEL but less than the seasonal AWEL. Based on the sample results for the effluent, the limitations appear to put the Discharger in immediate non-compliance. New or modified control measures may be necessary in order to comply with the effluent limitations, and the new or modified control measures cannot be designed, installed and put into operation within 30 calendar days.

The Facility is designed to provide tertiary treatment and fully nitrify the wastewater and is implementing nutrient removal upgrades. Therefore, the Central Valley Water Board finds that immediate compliance with the ammonia limits is feasible.

ii. **Dieldrin**

- (a) **WQO.** The CTR includes a criterion of 0.14 nanograms per liter (ng/L) for dieldrin for the protection of human health for waters from which both water and organisms are consumed.
- (b) **RPA Results.** The maximum effluent concentration (MEC) for dieldrin was 3.1 ng/L while the dieldrin was not detected in the upstream receiving water. Therefore, dieldrin in the discharge has a reasonable potential to cause or contribute to an instream

excursion above the CTR criterion for the protection of human health.

- (c) **WQBELs.** Due to no assimilative capacity, dilution credits are not allowed for development of the WQBELs for dieldrin. This Order contains a final AMEL and maximum daily effluent limitation (MDEL) for dieldrin of 0.14 ng/L and 0.34 ng/L, respectively, based on the CTR criterion for the protection of human health.
- (d) **Plant Performance and Attainability.** Analysis of the effluent data shows that the MEC of 3.1 ng/L is greater than applicable WQBELs. Based on the sample results for the effluent, the limitations appear to put the Discharger in immediate non-compliance. New or modified control measures may be necessary in order to comply with the effluent limitations, and the new or modified control measures cannot be designed, installed and put into operation within 30 calendar days and a compliance schedule may be needed.

iii. **Nitrate and Nitrite**

- (a) **WQO.** DDW has adopted Primary MCLs for the protection of human health for nitrite and nitrate that are equal to 1 mg/L and 10 mg/L (measured as nitrogen), respectively. DDW has also adopted a Primary MCL of 10 mg/L for the sum of nitrate and nitrite, measured as nitrogen.

U.S. EPA has developed a primary MCL and an MCL goal of 1 mg/L for nitrite (as nitrogen). For nitrate, U.S. EPA has developed Drinking Water Standards (10 mg/L as Primary MCL) and NAWQC for protection of human health (10 mg/L for non-cancer health effects).

- (b) **RPA Results.** The Facility is a POTW that treats domestic wastewater. Untreated domestic wastewater contains ammonia in concentrations that is harmful to aquatic life and exceed the Basin Plan's narrative toxicity objective. The Discharger currently uses nitrification/denitrification to remove ammonia, nitrite, and nitrate from the waste stream. Inadequate or incomplete treatment may result in the discharge of nitrate and/or nitrite to the receiving stream in concentrations that may exceed the Primary MCL and would violate the Basin Plan's narrative chemical constituents' objective. Therefore, the Central Valley Water Board finds the discharge has a reasonable potential to cause or contribute to an instream excursion above the Primary MCL and WQBELs are required for nitrate plus nitrite.

- (c) **WQBELs.** Due to no assimilative capacity, dilution credits are not allowed for development of the WQBELs for nitrate plus nitrite. This Order contains an AMEL and AWEL for nitrate plus nitrite of 10 mg/L and 20 mg/L, respectively, based on the Basin Plan's narrative chemical constituents objective for protection of the MUN beneficial use. These effluent limitations are included in this Order to assure the treatment process adequately nitrifies and denitrifies the waste stream to protect the beneficial use of municipal and domestic supply.
- (d) **Plant Performance and Attainability.** Analysis of the effluent data shows that the MEC of 11 mg/L is less than the applicable AWEL. The Central Valley Water Board concludes, therefore, that immediate compliance with these effluent limitations is feasible.

iv. Pathogens

- (a) **WQO.** DDW has developed reclamation criteria, CCR, Division 4, Chapter 3 (Title 22), for the reuse of wastewater. Title 22 requires that for spray irrigation of food crops, parks, playgrounds, schoolyards, and other areas of similar public access, wastewater be adequately disinfected, oxidized, coagulated, clarified, and filtered, and that the effluent total coliform levels not exceed 2.2 MPN/100 mL as a 7-day median; 23 MPN/100 mL, not to be exceeded more than once in a 30-day period; and 240 MPN/100 mL, at any time.

Title 22 is not directly applicable to surface waters; however, the Central Valley Water Board finds the stringent disinfection criteria are appropriate since the undiluted effluent may be used for the irrigation of food crops and/or for body-contact water recreation. Coliform organisms are intended as an indicator of the effectiveness of the entire treatment train and the effectiveness of removing other pathogens.

- (b) **RPA Results.** Raw domestic wastewater inherently contains human pathogens that threaten human health and life, and constitute a threatened pollution and nuisance under CWC section 13050 if discharged untreated to the receiving water. The beneficial uses of San Joaquin River include municipal and domestic supply, water contact recreation, and agricultural irrigation supply, and there is, at times, less than 20:1 dilution. To protect these beneficial uses, the Central Valley Water Board finds that the wastewater must be disinfected and adequately treated to prevent disease. Although the Discharger provides disinfection, inadequate or incomplete disinfection creates the potential for pathogens to be discharged. Therefore, the Central

Valley Water Board finds the discharge has reasonable potential for pathogens and WQBELs are required.

- (c) **WQBELs.** Special Provisions section VI.C.6.a of this Order requires, “Wastewater shall be oxidized, coagulated, filtered, and adequately disinfected pursuant to the State Water Board, DDW reclamation criteria, CCR, Title 22, division 4, chapter 3, (Title 22), or equivalent.” In accordance with the requirements of Title 22, this Order includes effluent limitations for total coliform organisms of 2.2 MPN/100 mL as a 7-day median; 23 MPN/100 mL, not to be exceeded more than once in a 30-day period; and 240 MPN/100 mL as an instantaneous maximum.

The tertiary treatment process, or equivalent, is capable of reliably treating wastewater to a turbidity level of 2 nephelometric turbidity units (NTU) as a daily average. Failure of the filtration system such that virus removal is impaired would normally result in increased particles in the effluent, which result in higher effluent turbidity. Turbidity has a major advantage for monitoring filter performance. Coliform testing, by comparison, is not conducted continuously and requires several hours, to days, to identify high coliform concentrations. Therefore, in addition to total coliform organisms effluent limitations, this Order includes operational specifications for turbidity of 2 NTU as a daily average; 5 NTU, not to be exceeded more than 5 percent of the time within a 24-hour period; and 10 NTU as an instantaneous maximum.

Final WQBELs for BOD₅ and TSS are also required based on the technical capability of the tertiary process. The tertiary treatment standards for BOD₅ and TSS are indicators of the effectiveness of the tertiary treatment process. The principal design parameter for wastewater treatment plants is the daily BOD₅ and TSS loading rates and the corresponding removal rate of the system. The application of tertiary treatment processes results in the ability to achieve lower levels for BOD₅ and TSS than the technology-based secondary standards. Therefore, this Order requires AMELs for BOD₅ and TSS of 10 mg/L, which is technically based on the capability of a tertiary system.

This Order contains effluent limitations for BOD₅, total coliform organisms, and TSS and requires a tertiary level of treatment, or equivalent, necessary to protect the beneficial uses of the receiving water. The Central Valley Water Board has previously

considered the factors in Water Code section 13241 in establishing these requirements.

Final WQBELs for BOD₅ and TSS are based on the technical capability of the tertiary process, which is necessary to protect the beneficial uses of the receiving water. BOD₅ is a measure of the amount of oxygen used in the biochemical oxidation of organic matter. The tertiary treatment standards for BOD₅ and TSS are indicators of the effectiveness of the tertiary treatment process. The principal design parameter for wastewater treatment plants is the daily BOD₅ and TSS loading rates and the corresponding removal rate of the system. The application of tertiary treatment processes results in the ability to achieve lower levels for BOD₅ and TSS than the secondary standards currently prescribed. Therefore, this Order requires AMELs for BOD₅ and TSS of 10 mg/L, which is technically based on the capability of a tertiary system. In addition to the average weekly and average monthly effluent limitations, a daily maximum effluent limitation for BOD₅ and TSS is included in the Order to ensure that the treatment works are not organically overloaded and operate in accordance with design capabilities.

- (d) **Plant Performance and Attainability.** The Facility provides tertiary treatment and utilizes an ultraviolet disinfection system that is designed to achieve Title 22 criteria. Therefore, the Central Valley Water Board concludes that immediate compliance with these effluent limitations is feasible for tertiary treated discharges from the Facility.

v. **pH**

- (a) **WQO.** The Basin Plan includes a water quality objective for surface waters (except for Goose Lake) that the “pH shall not be depressed below 6.5 nor raised above 8.5.”
- (b) **RPA Results.** Raw domestic wastewater inherently has variable pH. Additionally, some wastewater treatment processes can increase or decrease wastewater pH which if not properly controlled, would violate the Basin Plan’s numeric objective for pH in the receiving water. Therefore, reasonable potential exists for pH and WQBELs are required.
- (c) **WQBELs.** Effluent limitations for pH of 6.5 as an instantaneous minimum and 8.5 as an instantaneous maximum are included in this Order based on protection of the Basin Plan objectives for pH.

- (d) **Plant Performance and Attainability.** Analysis of the effluent data shows that the pH ranged from 6.5 to 7.7 which is less than the applicable WQBELs. The Central Valley Water Board concludes, therefore, that immediate compliance with these effluent limitations is feasible.

vi. **Temperature**

- (a) **WQO.** The Thermal Plan requires that, “The maximum temperature shall not exceed the natural receiving water temperature by more than 20°F.”
- (b) **RPA Results.** Treated domestic wastewater is an elevated temperature waste, which could cause or threaten to cause the receiving water temperature to exceed temperature objectives established in the Thermal Plan. Therefore, reasonable potential exists for temperature and WQBELs are required.

The Facility is a POTW that treats domestic wastewater, which is an elevated temperature waste. This provides the basis for the discharge to have a reasonable potential to cause or contribute to an excursion above Thermal Plan requirements.

- (c) **WQBELs.** To ensure compliance with the Thermal Plan, an effluent limitation for temperature is included in this Order.
- (d) **Plant Performance and Attainability.** Monitoring data indicates that consistent compliance with the requirements of the Thermal Plan is feasible.

4. **WQBEL Calculations**

- a. This Order includes WQBELs for ammonia, BOD₅, chlorpyrifos, diazinon, dieldrin, mercury, methylmercury, nitrate plus nitrite, pH, temperature, total coliform, and TSS. The general methodology for calculating WQBELs based on the different criteria/objectives is described in subsections IV.C.4.b through e, below. See Attachment H for the WQBEL calculations.
- b. **Effluent Concentration Allowance.** For each water quality criterion/objective, the ECA is calculated using the following steady-state mass balance equation from section 1.4 of the SIP:

$$\begin{aligned} \text{ECA} &= C + D(C - B) \text{ where } C > B, \text{ and} \\ \text{ECA} &= C \text{ where } C \leq B \end{aligned}$$

where:

ECA = effluent concentration allowance
D = dilution credit

C= the priority pollutant criterion/objective
B= the ambient background concentration.

According to the SIP, the ambient background concentration (B) in the equation above shall be the observed maximum with the exception that an ECA calculated from a priority pollutant criterion/objective that is intended to protect human health from carcinogenic effects shall use the arithmetic mean concentration of the ambient background samples.

- c. **Primary and Secondary MCLs.** For non-priority pollutants with primary MCLs to protect human health (e.g., nitrate plus nitrite), the AMEL is set equal to the primary MCL and the AWEL is calculated using the AWEL/AMEL multiplier, where the AWEL multiplier is based on a 98th percentile occurrence probability and the AMEL multiplier is from Table 2 of the SIP.

For non-priority pollutants with secondary MCLs that protect public welfare (e.g., taste, odor, and staining), WQBELs were calculated by setting the LTA equal to the secondary MCL and using the AMEL multiplier to set the AMEL. The AWEL was calculated using the AWEL multiplier from Table 2 of the SIP.

- d. **Aquatic Toxicity Criteria.** For priority pollutants with acute and chronic aquatic toxicity criteria, the WQBELs are calculated in accordance with section 1.4 of the SIP. The ECAs are converted to equivalent long-term averages (i.e. LTA_{acute} and $LTA_{chronic}$) using statistical multipliers and the lowest LTA is used to calculate the AMEL and MDEL using additional statistical multipliers. For non-priority pollutants, WQBELs are calculated using similar procedures, except that an AWEL is determined utilizing multipliers based on a 98th percentile occurrence probability.
- e. **Human Health Criteria.** For priority pollutants with human health criteria, the WQBELs are calculated in accordance with section 1.4 of the SIP. The AMEL is set equal to the ECA and the MDEL is calculated using the MDEL/AMEL multiplier from Table 2 of the SIP. For non-priority pollutants with human health criteria, WQBELs are calculated using similar procedures, except that an AWEL is established using the AWEL/AMEL multiplier from Table 2 of the SIP.

$$AMEL = mult_{AMEL} \left[\min \left(\overbrace{M_A ECA_{acute}, M_C ECA_{chronic}}^{LTA_{acute}} \right) \right]$$

$$MDEL = mult_{MDEL} \left[\min \left(\underbrace{M_A ECA_{acute}, M_C ECA_{chronic}}^{LTA_{chronic}} \right) \right]$$

$$MDEL_{HH} = \left(\frac{mult_{MDEL}}{mult_{AMEL}} \right) AMEL_{HH}$$

where:

mult_{AMEL} = statistical multiplier converting minimum LTA to AMEL

mult_{MDEL} = statistical multiplier converting minimum LTA to MDEL

M_A = statistical multiplier converting acute ECA to LTA_{acute}

M_C = statistical multiplier converting chronic ECA to LTA_{chronic}

**Summary of Water Quality-Based Effluent Limitations
Discharge Point 001**

Table F-9. Summary of Water Quality-Based Effluent Limitations

Parameter	Units	Effluent Limitations
Ammonia Nitrogen, Total (as N) (1 April through 30 November)	mg/L	AMEL 1.9 AWEL 4.0
Ammonia Nitrogen, Total (as N) (1 April through 30 November)	lbs/day (see table note 1)	AMEL 160 AWEL 330
Ammonia Nitrogen, Total (as N) (1 April through 30 November)	lbs/day (see table note 2)	AMEL 200 AWEL 430
Ammonia Nitrogen, Total (as N) (1 December through 31 March)	mg/L	AMEL 2.4 AWEL 6.9
Ammonia Nitrogen, Total (as N) (1 December through 31 March)	lbs/day (see table note 1)	AMEL 200 AWEL 570
Ammonia Nitrogen, Total (as N) (1 December through 31 March)	lbs/day (see table note 2)	AMEL 260 AWEL 740
Biochemical Oxygen Demand (5-day @ 20°C)	mg/L	AMEL 10 AWEL 15

Parameter	Units	Effluent Limitations
Chlorpyrifos	µg/L	SAMEL ≤ 1.0 SAWEL ≤ 1.0
Diazinon	µg/L	SAMEL ≤ 1.0 SAWEL ≤ 1.0
Dieldrin	ng/L	AMEL 0.14 MDEL 0.34
Mercury, Total Effective Until 30 December 2030	grams/year	Annual total max loading 90
Methylmercury Effective 31 December 2030	grams/year	Annual total max loading 0.38
Nitrate Plus Nitrite (as N)	mg/L	AMEL 10 AWEL 20
pH	Standard units	Instantaneous min 6.5 Instantaneous max 8.5
Temperature	°F	Instantaneous Max Differential 20
Total Coliform Organisms	MPN/100 mL	7-day median 2.2 Once in 30-days 23 Any time 240
Total Suspended Solids	mg/L	AMEL 10 AWEL 15

Table F-9 Notes:

1. Mass-based limits are based on an average dry weather flow of 9.87 MGD.
2. Mass-based limits are based on an average dry weather flow of 12.87 MGD.
3. **Diazinon and Chlorpyrifos.** Effluent limitations for diazinon and chlorpyrifos are based on the concentrations that shall not exceed the sum of one (1.0) as identified below:
 - a. Average Monthly Effluent Limitation (AMEL)

$$\text{SAMEL} = \text{CD M-avg}/0.079 + \text{CC M-avg}/0.012 \leq 1.0$$

CD M-AVG = average monthly diazinon effluent concentration in µg/L
CC M-AVG = average monthly chlorpyrifos effluent concentration in µg/L.
 - b. Average Weekly Effluent Limitation (AWEL)

$$\text{SAWEL} = \text{CD W-avg}/0.14 + \text{CC W-avg}/0.021 \leq 1.0$$

CD W-AVG = average weekly diazinon effluent concentration in µg/L.
CC W-AVG = average weekly chlorpyrifos effluent concentration in µg/L.
4. **Mercury.** The effluent limitation for mercury is an interim effluent limitation based on the calendar year annual mercury load that applies in lieu of the final effluent limitation for methylmercury.
5. **Methylmercury.** The effluent limitation for methylmercury is based on the calendar year annual methylmercury load in accordance with the Delta Mercury Control Program,

effective 31 December 2030.

6. **Temperature.** The temperature effluent limitation is based on the maximum calculated temperature difference between the natural receiving water temperature and the final effluent temperature.

5. Whole Effluent Toxicity (WET)

- a. **Chronic Toxicity.** The chronic aquatic toxicity water quality objective is expressed as a null hypothesis and an alternative hypothesis with a regulatory management decision (RMD) of 0.75, where the following null hypothesis, Ho, shall be used

Ho: Mean response (ambient water) \leq 0.75 • mean response (control)

And where the following alternative hypothesis, Ha, shall be used:

Ha: Mean response (ambient water) $>$ 0.75 • mean response (control)

Attainment of the water quality objective is demonstrated by conducting chronic aquatic toxicity testing and rejecting this null hypothesis in accordance with the Test of Significant Toxicity (TST) statistical approach described in National Pollutant Discharge Elimination System Test of Significant Toxicity Implementation Document (EPA 833-R-10-003, 2010), Appendix A, Figure A-1 and Table A-1 (Chronic Freshwater and East Coast Methods) and Appendix B, Table B-1. When the null hypothesis is rejected, the alternative hypothesis is accepted in its place, and there is no exceedance of the chronic aquatic toxicity water quality objective. Failing to reject the null hypothesis (referred to as a “fail”) is equivalent to an exceedance of the chronic aquatic toxicity water quality objective.

To evaluate compliance with the Statewide Toxicity Provisions aquatic toxicity numeric objectives, acute and chronic whole effluent toxicity testing data has been evaluated in the development of this Order.

The table below is chronic WET testing performed by the Discharger from 1 October 2019 through 30 September 2025.

Table F-10. Chronic Whole Effluent Toxicity Testing Results – Test of Significant Toxicity at the IWC (100 Percent Effluent)

Date	Fathead Minnow (<i>Pimephales promelas</i>) Survival		Fathead Minnow (<i>Pimephales promelas</i>) Growth		Water Flea (<i>Ceriodaphnia dubia</i>) Survival		Water Flea (<i>Ceriodaphnia dubia</i>) Reproduction		Green Algae (<i>Pseudokirchneriella subcapitata</i>) Growth	
	Pass/Fail	Percent Effect	Pass/Fail	Percent Effect	Pass/Fail	Percent Effect	Pass/Fail	Percent Effect	Pass/Fail	Percent Effect
10/2019	Pass	0	Pass	1.08	--	0	Pass	-6.71	Pass	-13.88
2/2020	Pass	0	Pass	-8.41	--	0	Pass	-2.06	Pass	-28.17
6/2/2020	Pass	0	Pass	-15.88	--	0	Pass	-13.58	Fail	55.60

Date	Fathead Minnow (<i>Pimephales promelas</i>) Survival		Fathead Minnow (<i>Pimephales promelas</i>) Growth		Water Flea (<i>Ceriodaphnia dubia</i>) Survival		Water Flea (<i>Ceriodaphnia dubia</i>) Reproduction		Green Algae (<i>Pseudokirchneriella subcapitata</i>) Growth	
	Pass/Fail	Percent Effect	Pass/Fail	Percent Effect	Pass/Fail	Percent Effect	Pass/Fail	Percent Effect	Pass/Fail	Percent Effect
6/13/2020	--	--	--	--	--	--	--	--	Pass	-88.05
9/2020	Pass	5.41	Pass	-5.63	--	0	Pass	1.00	Pass	-46.45
10/2020	Pass	-2.70	Pass	-0.42	--	0	Fail	16.02	Pass	-40.89
2/2021	Pass	-5.26	Pass	-0.11	--	0	Pass	-0.74	Pass	-57.61
5/2021	--	--	--	--	--	-11.11	Fail	16.34	--	--
8/2021	--	--	--	--	--	10.00	Fail	30.20	--	--
11/2021	--	--	--	--	--	0	Fail	22.48	--	--
2/2022	Pass	-2.56	Pass	-20.48	--	--	--	--	--	--
5/2022	Pass	0	Pass	0	--	--	--	--	--	--
7/2022	Pass	0	Pass	-11.43	--	--	--	--	--	--
10/2022	Pass	-5.26	Pass	-4.49	--	--	--	--	--	--
2/2023	--	--	--	--	--	--	--	--	Pass	-6.28
4/2023	--	--	--	--	--	--	--	--	Pass	-66.32
7/2023	--	--	--	--	--	--	--	--	Pass	-51.77
10/2023	--	--	--	--	--	--	--	--	Pass	-78.60
1/2024	Pass	0	Pass	2.62	--	0	Fail	21.73	Pass	-27.93
4/2024	Pass	2.56	Pass	-8.20	--	10.00	Fail	33.08	Pass	-34.28
5/2024	--	--	--	--	--	0	Pass	1.82	--	--
9/2024	Pass	0	Pass	-7.14	--	-11.11	Pass	4.20	Pass	-79.52
10/2024	Pass	2.50	Pass	-0.20	--	0	Pass	9.28	Pass	-51.03
2/2025	Pass	-3.13	Pass	-11.22	--	--	--	--	--	--
4/22/2025	Pass	1.54	Pass	-11.14	--	--	--	--	--	--
7/2025	Pass	-2.50	Pass	3.26	--	--	--	--	--	--

- i. **RPA.** Per the Statewide Toxicity Provisions, effluent limitations for chronic toxicity must be issued to the discharge without regard for a reasonable potential analysis for chronic toxicity. Water quality-based effluent limits for chronic toxicity are included in this order.
- ii. **WQBELs.** The following effluent limitations have been established for chronic whole effluent toxicity:

Chronic Whole Effluent Toxicity Maximum Daily Effluent Limitation (MDEL). No water flea (*Ceriodaphnia dubia*) chronic aquatic toxicity test shall result in a “Fail” at the Instream Waste Concentration (IWC) for the sub-lethal endpoint measured in the test and a percent effect for the survival endpoint greater than or equal to 50 percent.

Chronic Whole Effluent Toxicity Median Monthly Effluent Limitation (MMEL). No more than one *Ceriodaphnia dubia* chronic aquatic toxicity test initiated in a toxicity calendar month shall result in a “Fail” at the IWC for any endpoint.

D. Final Effluent Limitation Considerations

1. Mass-based Effluent Limitations

40 C.F.R section 122.45(f)(1) requires effluent limitations be expressed in terms of mass, with some exceptions, and 40 C.F.R. section 122.45(f)(2) allows pollutants that are limited in terms of mass to additionally be limited in terms of other units of measurement. This Order includes effluent limitations expressed in terms of mass and concentration. In addition, pursuant to the exceptions to mass limitations provided in 40 C.F.R. section 122.45(f)(1), some effluent limitations are not expressed in terms of mass, such as pH and temperature, and when the applicable standards are expressed in terms of concentration (e.g., CTR criteria and MCLs) and mass limitations are not necessary to protect the beneficial uses of the receiving water.

Mass-based effluent limitations were calculated based upon the design flow (Average Dry Weather Flow) permitted in WDR section III.E of this Order.

2. Averaging Periods for Effluent Limitations

40 C.F.R. section 122.45 (d) requires average weekly and average monthly discharge limitations for POTWs unless impracticable. For dieldrin, average weekly effluent limitations have been replaced with maximum daily effluent limitations in accordance with section 1.4 of the SIP. The rationale for using shorter averaging periods for these constituents is discussed in section IV.C.3 of this Fact Sheet.

3. Satisfaction of Anti-Backsliding Requirements

The CWA specifies that a revised permit may not include effluent limitations that are less stringent than the previous permit unless a less stringent limitation is justified based on exceptions to the anti-backsliding provisions contained in CWA sections 402(o) or 303(d)(4), or, where applicable, 40 C.F.R. section 122.44(l).

The effluent limitations in this Order are at least as stringent as the effluent limitations in the previous Order, with the exception of effluent limitations for acute whole effluent toxicity, ammonia, EC, and nitrate plus nitrite. The effluent limitations for these pollutants are less stringent than those in Order R5-2021-0003. This relaxation of effluent limitations is consistent with the anti-backsliding requirements of the CWA and federal regulations.

- a. **CWA section 402(o)(1) and 303(d)(4).** CWA section 402(o)(1) prohibits the establishment of less stringent water quality-based effluent limits

“except in compliance with section 303(d)(4).” CWA section 303(d)(4) has two parts: paragraph (A) which applies to nonattainment waters and paragraph (B) which applies to attainment waters.

- i. For waters where standards are not attained, CWA section 303(d)(4)(A) specifies that any effluent limit based on a TMDL or other WLA may be revised only if the cumulative effect of all such revised effluent limits based on such TMDLs or WLAs will assure the attainment of such water quality standards.
- ii. For attainment waters, CWA section 303(d)(4)(B) specifies that a limitation based on a water quality standard may be relaxed where the action is consistent with the antidegradation policy.

The San Joaquin River is considered an attainment water for acute whole effluent toxicity, ammonia, EC, and nitrate plus nitrite because the receiving water is not listed as impaired on the 303(d) list for this constituent. The exceptions in section 303(d)(4) address both waters in attainment with water quality standards and those not in attainment, i.e. waters on the section 303(d) impaired waters list. As discussed in section IV.D.4, below, relaxation or removal of the effluent limits complies with federal and state antidegradation requirements. Thus, relaxation of effluent limitations for ammonia and nitrate plus nitrite and removal of the effluent limitations for acute whole effluent toxicity and EC from Order R5-2021-0003 meets the exception in CWA section 303(d)(4)(B).

- b. **CWA section 402(o)(2).** CWA section 402(o)(2) provides several exceptions to the anti-backsliding regulations. CWA 402(o)(2)(B)(i) allows a renewed, reissued, or modified permit to contain a less stringent effluent limitation for a pollutant if information is available which was not available at the time of permit issuance (other than revised regulations, guidance, or test methods) and which would have justified the application of a less stringent effluent limitation at the time of permit issuance.

As described further in section IV.C.3.b of this Fact Sheet, updated information that was not available at the time Order R5-2021-0003 was issued indicates that acute whole effluent toxicity and EC do not exhibit reasonable potential to cause or contribute to an exceedance of water quality objectives in the receiving water. The updated information that supports the relaxation of effluent limitations for these constituents includes the following:

- i. **Acute whole effluent toxicity.** This Order removes the effluent limitation for acute whole effluent toxicity per standard approach under the new Statewide Toxicity Provisions, because chronic toxicity testing is generally protective of both acute and chronic toxicity, and whole

effluent toxicity data from October 2019 to September 2025 shows no reasonable potential for acute toxicity. This Order includes effluent limitations for chronic whole effluent toxicity, consistent with the Statewide Toxicity Provisions.

- ii. **EC.** This Order includes alternative effluent limitations for salinity by enforcing best management practices which includes ongoing participation in CV-SALTS. The Discharger is participating in the CV-SALTS's Salinity Control Program Alternative Pathway. This Order removes the effluent limitation for EC and establishes a performance-based effluent trigger for EC in accordance with the Alternative Pathway and the Bay-Delta Plan.
- c. **Ammonia and Nitrate Plus Nitrite.** For ammonia the seasonal AMELs and AWELs have changed from the previous Order and for nitrate plus nitrite the AWEL has changed from the previous Order. However, the effluent limit is not less stringent. In this case, the waste load allocation (WLA) in this Order and the previous Order are identical. The WLA provides a definition of effluent quality that is necessary to meet the water quality standards of the receiving water and is used to derive WQBELs that are used to enforce the WLA.

The TSD warns that, "*Direct use of a WLA as a permit limit creates a significant risk that the WLA will be enforced incorrectly, since effluent variability and the probability basis for the limit are not considered specifically.*" (TSD, p. 96) The SIP and TSD include identical procedures for calculating WQBELs that use the statistical variability of the effluent to convert the WLA to AMELs and MDELs.

The new effluent data used to calculate WQBELs for this Order has different statistical variability (i.e., coefficient of variation (CV) is different) than used in the previous Order. Changes in the CV can result in small changes to the effluent limits. However, the slight changes in effluent limits do not allow for an increase in the pollutants discharged. The TSD states, "*Since effluents are variable and permit limits are developed based on a low probability of exceedance, the permit limits should consider effluent variability and ensure that the requisite loading from the WLA is not exceeded under normal conditions. In effect then, the limits must "force" treatment plant performance, which, after considering acceptable effluent variability, will only have a low statistical probability of exceeding the WLA and will achieve the desired loadings.*" (TSD, p. 97) Therefore, although there are slight differences in the effluent limit, the WLA is identical, so the level of treatment needed to maintain compliance with the effluent limit remains the same. Consequently, the effluent limit is not less stringent than the previous Order, and there is no backsliding.

WQBELs for ammonia and nitrate plus nitrite were calculated based on monitoring data collected between April 2022 and March 2025, which is representative of current treatment plant performance. Therefore, Central Valley Water Board staff considers this effluent data to be the most representative and reliable dataset to use to determine current Facility performance and development of WQBELs.

The seasonal AMELs and AWELs for ammonia and the AWEL for nitrate plus nitrite in this Order was calculated as a higher value than in previous Order R5-2021-0003. However, the AMEL for nitrate plus nitrite remains the same. The WQBELs in both Orders are based on the same WLA (i.e., the WLA is based on the NAWQC freshwater aquatic life criterion for ammonia and California Primary MCL for nitrate plus nitrite). The reason for the change in the AMEL and AWEL is due to a change in the variability of the effluent data for ammonia and nitrate plus nitrite. The WQBELs, however, are equally protective of the beneficial uses. The level of treatment needed to maintain compliance with the effluent limits remains the same. Consequently, the effluent limits are not less stringent than the previous permit, and there is no backsliding.

4. Antidegradation Policies

This Order does not authorize lowering water quality as compared to the level of discharge authorized in the previous order, which is the baseline by which to measure whether degradation will occur. This Order does not allow for an increase in flow or mass of pollutants to the receiving water. The Order requires compliance with applicable federal technology-based standards and with WQBELs where the discharge could have the reasonable potential to cause or contribute to an exceedance of water quality standards. Accordingly, the permitted discharge is consistent with the antidegradation provisions of 40 C.F.R. section 131.12 and the State Anti-Degradation Policy.

This Order removes effluent limitations for acute toxicity and EC based on updated monitoring data demonstrating that the effluent does not cause or contribute to an exceedance of the applicable water quality criteria or objectives in the receiving water. The new chronic toxicity limitations are equally or more protective as the acute toxicity limitations that have been removed. This Order relaxes effluent limitations for ammonia and nitrate plus nitrite based on updated information that was not available at the time of Order R5-2021-0003. The removal and relaxation of WQBELs for these parameters will not result in an increase in pollutant concentration or loading, a decrease in the level of treatment or control, or a reduction of water quality. Therefore, the Central Valley Water Board finds that the removal and relaxation of the effluent limitations does not result in an increase in pollutants or any additional degradation of the receiving water. Thus, the removal and relaxation of effluent limitations is consistent with the antidegradation provisions of 40 C.F.R. section 131.12 and the State Anti-Degradation Policy.

- a. **Surface Water.** The permitted surface water discharge is consistent with the antidegradation provisions of 40 C.F.R. section 131.12 and the State Anti-Degradation Policy. Compliance with these requirements will result in the use of BPTC of the discharge. The impact on existing water quality will be insignificant.

- b. **Groundwater.** The Discharger utilizes a secondary effluent storage pond and Land Application Areas for storage and discharge of undisinfected secondary effluent for irrigation of agricultural fields. Domestic wastewater contains constituents such as total dissolved solids (TDS), specific conductivity, pathogens, nitrates, organics, metals and oxygen demanding substances (BOD). Percolation from the pond and land application areas may result in an increase in the concentration of these constituents in groundwater. The Discharger's available groundwater monitoring data indicate that underlying groundwater concentration levels for some constituents (e.g. EC/TDS, manganese, and nitrate) are elevated in some areas within the Facility. The increase in the concentration of these constituents in groundwater must be consistent with Resolution No. 68-16. Any increase in pollutant concentrations in groundwater must be shown to be necessary to allow wastewater utility service necessary to accommodate housing and economic expansion in the area and must be consistent with maximum benefit to the people of the State of California. Some degradation of groundwater by the Discharger is consistent with Resolution No. 68-16 provided that:
 - i. The degradation is limited in extent;
 - ii. The degradation after effective source control, treatment, and control is limited to waste constituents typically encountered in municipal wastewater as specified in the groundwater limitations in this Order;
 - iii. The Discharger minimizes the degradation by fully implementing, regularly maintaining, and optimally operating best practicable treatment and control (BPTC) measures; and
 - iv. The degradation does not result in water quality less than that prescribed in the Basin Plan.

The Discharger has made several improvements to reduce impacts to groundwater. The Discharger ceased applying biosolids to the Land Application Areas and since June 2003 hauled biosolids to an offsite landfill. Since mid-June 2024, the Discharger's biosolids disposal method includes land application and composting or discharge to a landfill conducted by Synagro. The Discharger also supplemented its drinking water supply with surface water in August 2005 that reduced the salinity of the discharge, and added nitrification-denitrification facilities in July 2006 to its treatment system to reduce total nitrogen. These operational changes and Facility upgrades are considered appropriate BPTCs.

In 2007, the Facility was also modified to fully separate the food-processing waste received from Eckert Cold Storage to discharge into the Facility's food receiving and processing wastewater pond, which is tetra lined, and then applied to agricultural land as needed. As approved by the Central Valley Water Board and USEPA, Eckert was removed from the Discharger's Pretreatment Program, and instead, is regulated through a local ordinance wastewater discharge permit. The local ordinance in part requires Eckert to submit reports, sample their discharge, and develop any plans (e.g. pollution prevention) that are deemed necessary. Eckert Cold Storage is a seasonal discharger that processes frozen vegetables, cabbage and a variety of peppers. The food processing wastewater is pretreated by screening, DAF system, and pH neutralization before discharging to the pond.

The Discharger was required in previous Order R5-2009-0095 to perform a BPTC Evaluation to ensure that land application of its effluent is consistent with the State Water Board Resolution No 68-16. In October 2012 the Discharger submitted a BPTC Evaluation that considered several constituents of concern (i.e., total coliform organisms, TDS, electrical conductivity, nitrate, nitrite, pH, and ammonia). It was determined that degradation was occurring in downgradient wells for EC/TDS and nitrate (as N).

- v. **EC/TDS.** The Discharger has reduced the salinity levels in its effluent through improvements in the municipal water supply. The salinity of the irrigation water is currently lower than the underlying groundwater and it is expected that over time the groundwater underlying the fields should improve. However, an overall improvement in down-gradient groundwater quality in conjunction with improvement in effluent quality with respect to salts has not occurred. This may be due to continued leaching of accumulated salts in the unsaturated zone that are masking effects of improved effluent quality in down-gradient wells. This Order includes a performance-based TDS trigger for the wastewater applied to the fields, which ensures the salinity of the wastewater will not increase over the current levels. If the trigger is exceeded the Discharger would be required to conduct an evaluation to determine the reason(s) for the increased TDS concentrations. The evaluation would include an explanation of the increased concentrations and a determination if it represents an increase in mass loading of TDS to the Land Application Areas that would require an Antidegradation Analysis update, including additional BPTC evaluations, to demonstrate the increased mass loading is consistent with the Antidegradation Policy.
- vi. **Nitrate as N.** Overall, nitrate (as N) concentrations appear to be improving in the groundwater underlying the fields, though

concentrations are still above the Primary MCL in most down-gradient wells and at or below the Primary MCL in the background well. The Facility has been upgraded to include nitrification/denitrification and land application area specifications are included to minimize nitrogen discharges to groundwater. This Order requires that the total nitrogen mass loading to the Land Application Areas shall not exceed the agronomic rate for the crop grown and the hydraulic loading rate shall also be at agronomic rates. The Discharger submits Nutrient Management Plans annually indicating that total nitrogen loadings are below crop demands at all times but that the agronomic hydraulic loading rate is occasionally exceeded in some months. Starting in the 2015 planting season, the Discharger switched to planting alfalfa, a year-round crop with stable water and nutrient demand throughout the year. The Discharger has also improved the operation efficiency of its water delivery system to the fields. As a result, nitrate (as N) concentrations have been steadily decreasing in the groundwater underlying the fields. Since switching to alfalfa, total nitrogen loadings have been below crop demand and below the agronomic hydraulic loading rate of the crops.

- vii. **Manganese.** Dissolved manganese concentrations are very low in background groundwater and in most of the downgradient groundwater monitoring wells. However, the dissolved manganese concentrations in downgradient monitoring wells MW-5 and MW-9W ranges between 11 µg/L to 443 µg/L and 4.4 µg/L to 392 µg/L, respectively, which is much higher than the upgradient background well MW-AW concentrations of 0.16 µg/L to 6.0 µg/L. The wastewater being applied to the LAAs is low in manganese and the BOD₅ loading is not at levels that would result in reducing conditions that can mobilize metals in the soil. Based on the evaluation of the low wastewater manganese concentrations, the low BOD₅ concentrations of the irrigation water applied into the land application areas, field average irrigation cycle (about 10 days), shallow groundwater, and long term regional agricultural practices, staff determined that the difference in dissolved manganese concentrations among the downgradient wells is due to spatial and temporal variability. Similar groundwater characteristics in terms of spatial and temporal variability for manganese have also been observed and evaluated in City of Lathrop, which is north of Manteca and Oakwood Lake Water District, which is directly south of Manteca. Therefore, it is not appropriate to determine whether the discharge has caused degradation by a simple well-by-well comparison to a background value. The Discharger is required to continue implementing best management practices, which include, but are not limited to, maintaining an irrigation system that allows even

distribution of the BOD₅ loading into the LAAs to ensure the land application practices do not contribute to the elevated manganese.

The Discharger has made improvements to reduce the salinity in the irrigation water and this Order contains groundwater limitations, land application area specifications, and reclamation specifications for the protection of the beneficial uses of groundwater and is consistent with State Water Board Resolution 68- 16. Quarterly groundwater monitoring for nitrate, manganese, and EC/TDS is included in this Order. This Order carries forward groundwater limitations for total coliform organisms from previous Order R5-2021-0003 and adds Title 22 MCLs and a taste, odor, toxicity, and nuisance groundwater limitation to assure protection of beneficial uses of groundwater. Groundwater limitations for total dissolved solids and pH have not been retained from Order R5-2021-0003. For additional information see section V.B of this Fact Sheet.

5. Stringency of Requirements for Individual Pollutants

This Order contains both technology-based effluent limitations and WQBELs for individual pollutants. The technology-based effluent limitations consist of restrictions on BOD₅, pH, and TSS. Restrictions on BOD₅, pH, and TSS are discussed in section IV.B.2 of this Fact Sheet. This Order’s technology-based pollutant restrictions implement the minimum, applicable federal technology-based requirements. For BOD₅, pH, and TSS, both technology-based effluent limitations and water quality-based effluent limitations are applicable. The more stringent of these effluent limitations are implemented by this Order. These limitations are not more stringent than required by the CWA.

WQBELs have been derived to implement water quality objectives that protect beneficial uses. Both the beneficial uses and the water quality objectives have been approved pursuant to federal law and are the applicable federal water quality standards. To the extent that toxic pollutant WQBELs were derived from the CTR, the CTR is the applicable standard pursuant to 40 C.F.R. section 131.38. The procedures for calculating the individual WQBELs for priority pollutants are based on the CTR implemented by the SIP, which was approved by U.S. EPA on 18 May 2000. Collectively, this Order’s restrictions on individual pollutants are no more stringent than required to implement the requirements of the CWA.

**Summary of Final Effluent Limitations
Discharge Point 001**

Table F-11. Summary of Final Effluent Limitations

Parameter	Units	Effluent Limitations	Basis
Ammonia Nitrogen, Total (as N) (1 April through 30 November)	mg/L	AMEL 1.9 AWEL 4.0	NAWQC

Parameter	Units	Effluent Limitations	Basis
Ammonia Nitrogen, Total (as N) (1 April through 30 November)	lbs/day (see table note 2)	AMEL 160 AWEL 330	NAWQC
Ammonia Nitrogen, Total (as N) (1 April through 30 November)	lbs/day (see table note 3)	AMEL 200 AWEL 430	NAWQC
Ammonia Nitrogen, Total (as N) (1 December through 31 March)	mg/L	AMEL 2.4 AWEL 6.9	NAWQC
Ammonia Nitrogen, Total (as N) (1 December through 31 March)	lbs/day (see table note 2)	AMEL 200 AWEL 570	NAWQC
Ammonia Nitrogen, Total (as N) (1 December through 31 March)	lbs/day (see table note 3)	AMEL 260 AWEL 740	NAWQC
Biochemical Oxygen Demand (5-day @ 20°C)	mg/L	AMEL 10 AWEL 15	TTC
BOD ₅	% removal	Instantaneous Min 85	CFR
Chlorpyrifos	µg/L	SAMEL ≤ 1.0 SAWEL ≤ 1.0	TMDL
Diazinon	µg/L	SAMEL ≤ 1.0 SAWEL ≤ 1.0	TMDL
Dieldrin	ng/L	AMEL 0.14 MDEL 0.34	CTR
Mercury, Total Effective Until 30 December 2030	grams/year	Annual total max loading 90	TMDL
Methylmercury Effective 31 December 2030	grams/year	Annual total max loading 0.38	TMDL
Nitrate Plus Nitrite (as N)	mg/L	AMEL 10 AWEL 20	MCL
pH	Standard units	Instantaneous min 6.5 Instantaneous max 8.5	BP
Temperature	°F	Instantaneous Max Differential 20	TP
Total Coliform Organisms	MPN/100 mL	7-day median 2.2 Once in 30-days 23 Any time 240	Title 22
Total Suspended Solids (TSS)	mg/L	AMEL 10 AWEL 15	TTC
TSS	% removal	Instantaneous Min 85	CFR

Table F-11 Notes:

- BP** – Based on water quality objectives contained in the Basin Plan.
CFR – Based on secondary treatment standards contained in 40 CFR part 133.
CTR – Based on water quality criteria contained in the California Toxics Rule and applied

as specified in the SIP.

MCL – Based on the Primary Maximum Contaminant Level.

NAWQC – Based on U.S. EPA’s National Ambient Water Quality Criteria for the protection of freshwater aquatic life.

Title 22 – Based on State Water Board Division of Drinking Water Reclamation Criteria, CCR, Division 4, Chapter 3 (Title 22).

TMDL – Based on the TMDL for salinity and boron in the lower San Joaquin River.

TP – Based on water quality objectives contained in the Thermal Plan.

TTC – Based on tertiary treatment capability. These effluent limitations reflect the capability of a properly operated tertiary treatment plant.

2. Mass-based limits are based on an average dry weather flow of 9.87 MGD.
3. Mass-based limits are based on an average dry weather flow of 12.87 MGD.
4. **Diazinon and Chlorpyrifos.** Effluent limitations for diazinon and chlorpyrifos are based on the concentrations that shall not exceed the sum of one (1.0) as identified below:
 - a. Average Monthly Effluent Limitation (AMEL)
$$S_{AMEL} = CD\ M\text{-avg}/0.079 + CC\ M\text{-avg}/0.012 \leq 1.0$$

CD M-AVG = average monthly diazinon effluent concentration in µg/L
CC M-AVG = average monthly chlorpyrifos effluent concentration in µg/L.
 - b. Average Weekly Effluent Limitation (AWEL)
$$S_{AWEL} = CD\ W\text{-avg}/0.14 + CC\ W\text{-avg}/0.021 \leq 1.0$$

CD W-AVG = average weekly diazinon effluent concentration in µg/L.
CC W-AVG = average weekly chlorpyrifos effluent concentration in µg/L.
5. **Mercury.** The effluent limitation for mercury is an interim effluent limitation based on the calendar year annual mercury load that applies in lieu of the final effluent limitation for methylmercury.
6. **Methylmercury.** The effluent limitation for methylmercury is based on the calendar year annual methylmercury load in accordance with the Delta Mercury Control Program, effective 31 December 2030.
7. **Temperature.** The temperature effluent limitation is based on the maximum calculated temperature difference between the natural receiving water temperature and the final effluent temperature.

E. Interim Effluent Limitations

The State Water Board’s Resolution 2008-0025 “Policy for Compliance Schedules in National Pollutant Discharge Elimination System Permits” (Compliance Schedule Policy) requires the Central Valley Water Board to establish interim numeric effluent limitations in this Order for compliance schedules longer than 1 year. As discussed in section VI.B.7 of this Fact Sheet, the Central Valley Water Board is approving a compliance schedule longer than 1 year for methylmercury. The Compliance

Schedule Policy requires that interim effluent limitations be based on current Facility performance or existing permit limitations, whichever is more stringent. Consistent with the Delta Mercury Control Program, this Order includes interim effluent limitations for total mercury based on Facility performance.

1. **Compliance Schedule for Methylmercury.** This Order contains a final effluent limitation for methylmercury based on the Basin Plan's Delta Mercury Control Program that became effective on 20 October 2011. The Discharger has complied with the application requirements in paragraph 4 of the State Water Board's Compliance Schedule Policy, and the Discharger's application demonstrates the need for additional time to implement actions to comply with the final effluent limitations, as described below. Therefore, a compliance schedule for compliance with the effluent limitations for methylmercury is established in the Order.

A compliance schedule is necessary because the Discharger must implement actions, including a Phase 1 Methylmercury Control Study and possible upgrades to the Facility, to comply with the final effluent limitations.

The Discharger has made diligent efforts to quantify pollutant levels in the discharge and the sources of the pollutant in the waste stream. The Discharger conducted quarterly monitoring for mercury and methylmercury during the term of Order R5-2021-0003. The Discharger has developed and continues to implement a pollution prevention plan for mercury, which was submitted to the Central Valley Water Board on 24 November 2015, and provided annual progress reports during the term of Order R5-2021-0003.

The compliance schedule is as short as possible. The Central Valley Water Board will use the Phase 1 Control Studies' results and other information to consider amendments to the Delta Mercury Control Program during the Phase 1 Delta Mercury Control Program Review. Therefore, at this time, it is uncertain what measures must be taken to consistently comply with the WLA for methylmercury. The interim effluent limits and final compliance date may be modified at the completion of Phase 1.

Interim performance-based limitations have been included in this Order. The interim limitations were determined as described in section IV.E.2, below, and are in effect until the final limitations take effect. The interim numeric effluent limitations and source control measures will result in the highest discharge quality that can reasonably be achieved until final compliance is attained.

2. **Interim Limits for Total Mercury.** The Compliance Schedule Policy requires the Central Valley Water Board to establish interim requirements and dates for their achievement in the NPDES permit. Interim numeric effluent limitations are required for compliance schedules longer than 1 year. Interim effluent limitations must be based on current treatment plant performance or previous final permit limitations, whichever is more stringent. When feasible, interim

limitations must correspond with final permit effluent limitations with respect to averaging bases (e.g., AMEL, MDEL, AWEL, etc.) for effluent limitations for which compliance protection is intended.

The interim effluent limitations for total mercury are based on Facility performance. The Delta Mercury Control Program requires POTWs to limit their discharges of inorganic (total) mercury to Facility performance-based levels during Phase 1. The interim inorganic (total) mercury effluent mass limit is to be derived using current, representative data and shall not exceed the 99.9th percentile of the 12-month running effluent inorganic (total) mercury mass loads. At the end of Phase 1, the interim inorganic (total) mercury mass limit will be reevaluated and modified as appropriate. The Delta Mercury Control Program also requires interim limits established during Phase 1 and allocations will not be reduced as a result of early actions that result in reduced inorganic (total) mercury and/or methylmercury in discharges.

This Order retains the interim performance-based effluent limitation for total mercury from Order R5-2021-0003, which is consistent with the intent of the TMDL to not penalize dischargers for early actions to reduce mercury. The interim effluent limitation for total mercury shall apply in lieu of the final effluent limitation for methylmercury.

The Central Valley Water Board finds that the Discharger can undertake source control and treatment plant measures to maintain compliance with the interim limitations included in this Order. Interim limitations are established when compliance with final effluent limitations cannot be achieved by the existing discharge. Discharge of constituents in concentrations in excess of the final effluent limitations, but in compliance with the interim effluent limitations, can significantly degrade water quality and adversely affect the beneficial uses of the receiving stream on a long-term basis. The interim limitations, however, establish an enforceable ceiling concentration until compliance with the effluent limitation can be achieved.

F. Land Discharge Specifications

1. The Land Discharge Specifications are necessary to protect the beneficial uses of the groundwater.
2. **Scope and Authority.** Title 27 regulations conditionally exempt certain activities from its provisions. Several exemptions are relevant to the discharge of wastewater to land, and the operation of treatment and/or storage ponds, associated with the Facility.
3. **Applicable Waste Discharge Requirements.** Since the Discharger applies undisinfected secondary recycled municipal wastewater that is mixed with food processing industrial wastewater from Eckert Cold Storage, which is a food processor of frozen vegetables (e.g., cabbage and a variety of peppers), the

Recycling General Order requirements cannot be applied to the Land Application Areas. Food processing wastewater is of higher strength than secondary treated domestic wastewater and requires additional regulations to protect groundwater and prevent nuisance. Food process wastewater contains greater concentrations of biochemical oxygen demand, total nitrogen, and total dissolved solids. Consequently, this Order contains the following waste discharge requirements:

- a. **Hydraulic, Nitrogen, and BOD₅ Loading.** Soils within the land application area provide a matrix for biodegradation of the organic components of wastewater, which is measured as BOD. BOD is associated with both suspended solids and dissolved organic material. The BOD associated with suspended solids will remain close to the surface where the soil organisms have access to atmospheric oxygen to break the material down. The BOD in the dissolved organic material will percolate through the unsaturated zone of the soil and, under aerobic conditions, be removed during percolation. If the loading is too great, the soil will become anaerobic, and the crop and treatment process will fail.

The Discharger is required to obtain daily hydraulic and BOD₅ loading data and weekly total Nitrogen loading data per field when irrigation is occurring and to submit monthly reports. The Discharger's data indicates that the total monthly BOD₅ loading rates are low (e.g., <28 lbs/ac/day) and certifies that the loadings are at agronomic rates. However, the reports do not indicate the amount of loadings per field for each irrigation event.

Small and Decentralized Wastewater Management Systems by Crites and Tchobanoglous, states that land application is an effective process for BOD and pathogen removal. BOD loadings "on industrial rapid infiltration systems range from 100 to 600 lbs/acre/day." The authors recommend as a guideline for industrial wastewater discharges no more than 300 lbs/acre/day to avoid odor production. The municipal influent consists of residential and industrial users. Industrial users constitute less than one percent of the Facility's influent. Therefore, to ensure compliance with Discharge Prohibition III.E. and Groundwater Limitations V.B this Order contains a maximum BOD loading limit of 300 lbs/acre/day as a daily average based on this recommendation. Furthermore, because waste applications must be balanced to provide adequate plant nutrients and water while minimizing nuisance potential and percolation of waste constituents to the water table, this Order also requires hydraulic and total nitrogen loadings at agronomic rates.

- b. **TDS Trigger.** The salinity concentrations of the groundwater underlying the agricultural fields exceed background salinity levels. The Discharger has made improvements to its water supply that have resulted in

reductions in effluent salinity, the Discharger is implementing a pollution prevention plan for salinity, and requires Eckert Cold Storage to also implement pollution minimization for salinity. The recent TDS concentrations being applied to the fields are lower than the groundwater concentrations and substantially lower than the site-specific water quality objective. The Discharger submitted a BPTC evaluation in October 2012 that demonstrated the operational changes and Facility upgrades comply with the Antidegradation Policy based on the current TDS loadings. To ensure salinity concentrations do not increase significantly over current levels and the Discharger continues to implement BPTC in accordance with the Antidegradation Policy, this Order includes a performance-based TDS trigger for the irrigation water. The trigger was carried forward from Order R5-2021-0003 and was statistically calculated (i.e., 95th percentile) based on the annual average TDS concentrations from 2010-2014. The annual average TDS concentrations of the irrigation water shown in Table F-12 were below this trigger of 600 mg/L during the previous permit term.

Table F-12. Calendar Annual Average TDS concentrations applied to LAAs

Year	TDS Annual Average (mg/L)
2021	532
2022	505
2023	504
2024	500

4. **Prohibition to Discharge Hazardous Waste.** Hazardous compounds are not usually associated with domestic or food processing wastewater and when present are reduced in the discharge to inconsequential concentrations through treatment or dilution. Still it is inappropriate to allow degradation of groundwater with such constituents, and therefore, this Order contains a prohibition to discharge waste classified as “hazardous” under Title 23 CCR Chapter 15, Section 2521 (Section IV.A.4 of this Fact Sheet).

G. Recycling Specifications

Reclaimed water must meet the requirements of CCRs, Title 22, Division 4, Chapter 3. Water Recycling Criteria. The Discharger supplies recycled water for construction purposes and dust control, sanitary sewer cleaning, and landscape irrigation, and therefore, this Order contains reclamation requirements for the production of Title 22 disinfected tertiary recycled water supplied to the Discharger’s customers. These specifications are necessary to reduce public health concerns and comply with the requirements of Title 22. The Discharger submitted a Title 22 Engineering Report and Technical Report for use of recycled water, dated May 2019, which were reviewed and approved by DDW in June 2019. The Discharger was issued a Notice of Applicability for coverage under the State Water Board Recycled Water General

Order WQ 2016-0068-DDW, which regulates the use of reclaimed water. This Order only regulates the production of recycled water.

V. RATIONALE FOR RECEIVING WATER LIMITATIONS

A. Surface Water

On 4 March 2025, the U.S. Supreme Court issued a decision in the case of the City and County of San Francisco vs. U.S. Environmental Protection Agency (2025) 145 U.S. 704, which challenged some of the limits in NPDES permits. The Court ruled that “end result” provisions (e.g. receiving water limitations) are not allowed by the federal Clean Water Act and that NPDES permits must have specific requirements to meet water quality objectives and protect beneficial uses. Based on this ruling, no receiving water limitations are included in this Order.

The Clean Water Act and implementing regulations specify that effluent limitations are required when there is reasonable potential for a discharge to cause or contribute to an exceedance of any applicable water quality standard. A Reasonable Potential Analysis (RPA) is a key step taken by permit writers to determine if a discharge has the potential to violate water quality standards. An RPA includes characterization of the effluent and receiving waters and an assessment of the water quality standards to see if projected concentrations in the receiving water after mixing with the effluent have the “reasonable potential” (RP) to exceed the water quality criteria. Effluent limitations and other permit conditions are prescribed based on an evaluation of this information. RPAs and effluent limitation calculations follow established NPDES program procedures and requirements (State Water Resources Control Board, 2005 and U.S. Environmental Protection Agency, 1991).

This Order also requires regular effluent and receiving water sampling to document any potential effects to the receiving water. In addition, this Order requires characterization monitoring of priority pollutants in the upstream receiving water and effluent during the permit term. All Central Valley NPDES permits contain a general re-opener provision that allow the Central Valley Water Board to amend the permit and include conditions, effluent limitations, provisions, or prohibitions. This would include scenarios where monitoring data indicate the need for new effluent limitations to ensure receiving water quality objectives are met. As an additional assurance, this Order prohibits operational changes that would significantly impact the character of the waste discharge.

Nonetheless, the question remains as to whether an NPDES permit is adequately protective of water quality when the receiving water limitations are removed; or alternatively, whether additional conditions should be considered when removing receiving water limitations.

1. Below is a summary of the specific considerations for the removal of receiving water limitations. These considerations include associated effluent limitations,

best management practices (BMPs) and/or water quality monitoring requirements.

- a. **Bacteria.** On 7 August 2018 the State Water Board adopted Resolution No. 2018-0038 establishing Bacteria Provisions, which are specifically titled “Part 3 of the Water Quality Control Plan for Inland Surface Waters, Enclosed Bays, and Estuaries of California—Bacteria Provisions and a Water Quality Standards Variance Policy” and “Amendment to the Water Quality Control Plan for Ocean Waters of California—Bacteria Provisions and a Water Quality Standards Variance Policy.” The Bacteria Water Quality Objectives established in the Bacteria Provisions supersede any numeric water quality objective for bacteria for the REC-1 beneficial use contained in a water quality control plan before the effective date of the Bacteria Provision. However, the Statewide Bacteria Provisions provide that where a permit, waste discharge requirement (WDR), or waiver of WDR includes an effluent limitation or discharge requirement that is derived from a water quality objective or other guidance to control bacteria (for any beneficial use) that is more stringent than the Bacteria Water Quality Objective, the Bacteria Water Quality Objective would not be implemented in the permit, WDR, or waiver of WDR. Since this Order includes effluent limitations and discharge requirements equivalent to the DDW Title 22 disinfected tertiary reclamation criteria that are more stringent than the Statewide Bacteria Objectives, the Statewide Bacteria Objectives have not been implemented in this Order.

The Facility is a POTW that treats its water to tertiary standards and has strict total coliform limitations that meet Title 22 disinfection or equivalent standards. This Order contains total coliform effluent limitations based on the Title 22 disinfection or equivalent reclamation criteria, which are more stringent than the Statewide Bacteria Objectives described below.

- b. **Biostimulatory Substances and Dissolved Oxygen requirements.** The Basin Plan contains a biostimulatory narrative water quality objective (WQO) and dissolved oxygen numeric water quality objectives that have been incorporated into previous permits as receiving water limitations. Biostimulatory substances and low dissolved oxygen can cause eutrophication and excessive algal growth in the receiving water along with other water quality issues related to taste, odor, color and toxicity. Discharges with high Biological Oxygen Demand (BOD) and/or Chemical Oxygen Demand (COD) may contribute to dissolved oxygen problems downstream.

There is no RP for dissolved oxygen; however, this Order requires dissolved oxygen monitoring in the effluent and receiving waters. This Order requires frequent monitoring of dissolved oxygen in the receiving water as well as visual monitoring of the receiving water for fungi, slimes, or objectionable growths as an indication of the effects of the effluent to the receiving water from biostimulatory substances and decreased dissolved oxygen. This Order includes effluent limitations for BOD₅ and percent removal of BOD₅ and TSS

along with regular monitoring of Dissolved Organic Carbon (DOC) in the receiving water.

- c. **Chemicals, Pesticides, and Radioactive requirements.** The Basin Plan has narrative and numeric water quality objectives for chemicals, pesticides, and radionuclides that are typically used as receiving water limitations in NPDES permits. As with other water quality constituents, NPDES regulations require effluent limitations where existing data indicate reasonable potential to cause or contribute to an exceedance in the receiving water. Attachments G and H provide details regarding the specific chemical constituents with reasonable potential and associated effluent limitations. These effluent limitations ensure the protection of beneficial uses in the receiving water.

There is no RP based on existing data for any radioactive constituents on the characterization monitoring list. There is RP for dieldrin; however, this Order includes effluent limitations, effluent monitoring, and receiving water monitoring for dieldrin.

- d. **Color, Taste, and Odors requirements.** The Basin plan has a narrative water quality objective for color as well as one for taste and odors. These have been incorporated into previous permits as receiving water limitations. Color, taste, and odors are rarely concerns for tertiary treated wastewater discharges in the Central Valley, and no effluent limitations are included in this permit. However, frequent visual monitoring of the receiving water for discoloration and other potential nuisance conditions is required.
- e. **pH requirements.** The Basin Plan has narrative water quality objectives for pH that have been used as receiving water limitations in previous permits. A pH that is too high or too low can influence the solubility of metals and nutrients in the receiving water and impact the overall health of aquatic life.

The discharge does not have RP for pH based on existing data. However, the permit includes pH effluent limitations and requires frequent monitoring of pH in the receiving water.

- f. **Temperature requirements.** The Basin Plan has numeric receiving water limitations for receiving waters with beneficial uses of COLD or WARM to ensure the wastewater does not significantly increase the receiving water temperature above the natural receiving water temperature. Significant changes in temperature can affect the ability of aquatic organisms to survive in the receiving water.

There is no RP for temperature based on existing data. This Order does include effluent limits for temperature based on the Thermal Plan objectives and includes frequent temperature monitoring in the effluent and receiving water.

- g. **Toxicity requirements.** The Basin Plan contains a narrative water quality objective for toxicity that has been incorporated into previous permits as a receiving water limitation. However, with the adoption of the Statewide Toxicity Provisions (State Water Resources Control Board, 2021) in 2023, numeric aquatic toxicity water quality objectives were established along with required effluent limitations and/or targets for non-stormwater NPDES permits to ensure the protection of aquatic life beneficial uses in receiving waters. Elevated levels of ammonia are also known to be toxic to aquatic organisms.

This Order includes chronic whole effluent toxicity effluent limitations and requires frequent monitoring of chronic whole effluent toxicity. There is RP for ammonia in the effluent. This order includes seasonal ammonia limits and requires frequent monitoring of ammonia in the effluent.

- h. **Turbidity requirements.** The Basin Plan includes numeric turbidity water quality objectives that are based on existing turbidity in the receiving waters. These have been incorporated into previous permits as receiving water limitations.

The discharge does not have reasonable potential or effluent limitations for turbidity, however the permit requires frequent monitoring of turbidity in the receiving waters. The Facility is a POTW that treats their water to tertiary standards. The permit includes filtration system operating specifications with strict turbidity requirements to ensure disinfection systems are effective. These limitations are low enough to ensure protection of beneficial uses in the receiving water.

- i. **Floating Material, Oil and Grease, Suspended Sediments, Suspended Material, and Settleable Substances requirements.** The previous permit contained receiving water limitations relative to narrative water quality objectives in the Basin Plan for Floating Material, Oil and Grease, Suspended Sediments, Suspended Material and Settleable Substances. These constituents can affect water quality by reducing water clarity and light penetration which can ultimately lead to increased water temperatures, decreased dissolved oxygen levels, and eutrophication. Contamination from these substances can impact both aquatic and human health.

This Order requires frequent visual monitoring in the receiving waters for floating material, visible films, sheens or coating, suspended matter, and bottom deposits. This Order also includes numeric effluent limitations for Total Suspended Solids.

2. Review of Other Relevant Factors

In addition to the considerations listed in section V.A.1 above, Central Valley Water Board staff also considered the other relevant factors below in the review of receiving water limitations.

- a. **Synergistic effects.** Is there a known concern that the discharge will combine with the receiving water and produce adverse synergistic effects? For example, surface water discharges may be fully compliant with dissolved oxygen and narrative objectives, but may combine with poor conditions in the receiving water to cause harmful algal blooms (HABs), eutrophication, dissolved oxygen sag, toxic effects, taste and odor, and other harmful conditions. Is there the concern that the discharge when combined with the receiving water would have color concerns (e.g., mine discharge, floc due to pH change, etc.)?

There are no known concerns for adverse synergistic effects in the receiving water.

- b. **Limitations enforced within the receiving water.** Are there specific chemicals or pesticides that have Basin Plan objectives that are not enforced through effluent limitations? For example, certain organochlorine pesticides effluent limitations are based on numeric water quality objectives consistent with applicable regulations. However, more stringent Basin Plan objectives require the receiving water to be “non-detect” for these materials. In these circumstances, removing the receiving water limitation would result in reduced protections that are required under federal and state regulations.

The discharge does not demonstrate exceedances of the Basin Plan’s receiving water quality objectives for this category of chemicals and/or pesticides.

- c. **Other site-specific information.** Are there any special studies that have been conducted in the receiving water body/watershed or impairments that relate to existing receiving water limitations?

This Order considers the Clean Water Act 303(d) List of Impaired Water Bodies when they are developed. The receiving water has Total Maximum Daily Load (TMDL) requirements for chlorpyrifos, diazinon, and mercury. This Order includes effluent limitations for chlorpyrifos, diazinon, and mercury based on the TMDLs.

Salinity constituents are also a concern in Central Valley water bodies. The Discharger submitted a Notice of Intent for the Salinity Control Program indicating its intent to meet the Alternative Salinity Permitting Approach.

The Central Valley Water Board’s Pyrethroid Control Program, adopted in 2017, requires larger POTWs (> 1 million gallons a day of discharge) to monitor for pyrethroids to determine if they have RP. The Discharger conducted pyrethroid monitoring from 1 April 2022 to 31 March 2023 and submitted the results to the Central Valley Water Board. Staff reviewed the results and determined that they satisfy the pyrethroid monitoring requirements.

- d. **Data characterization.** Have the effluent and receiving water been fully characterized?

This Order requires characterization monitoring in the effluent and receiving water every permit term. A full scan of priority pollutant and other constituents of concern is required.

- e. **Compliance history.** Has the facility had any compliance issues meeting receiving water limitations during the most recent permit term (e.g., received a Notice of Violation for exceeding a receiving water limitation)? Overall, does the facility have any ongoing compliance issues (e.g., frequent operational upsets).

The Facility does not have ongoing compliance issues.

3. Review of Receiving Water Limitations.

Based on Central Valley Water Board staff review of the considerations presented above, existing permit provisions are adequate to ensure the Facility discharge consistently meets federal and state regulations for the protection of beneficial uses in the receiving water. The effluent limitations and receiving water monitoring in this Order along with the permit prohibitions and reopener provisions provide a multi-pronged approach to ensuring water quality standards are met. As such, receiving water limitations from the previous permit can be removed without the inclusion of additional conditions.

Table F-13. Receiving Water Limitations Review

Receiving Water Limitations Removed	Effluent Limitations and/or Monitoring	Other Relevant Factors
Bacteria (Numeric WQO)	No reasonable potential (RP), and receiving water limitation is not needed due to tertiary treatment standards. Total coliform effluent limitations are included.	
Biostimulatory Substances (Narrative WQO)	No RP based on effluent data, and BOD ₅ , TSS, and percent removal effluent limits are included. Receiving water monitoring for DOC and visual biostimulatory effects are included.	
Chemical Constituents (Narrative WQO)	No RP for radioactive constituents. Dieldrin effluent limitation and monitoring is required in the effluent.	Quarterly priority pollutant characterization monitoring (effluent and upstream receiving water) from 1 August 2027 through 31 July 2028.

Receiving Water Limitations Removed	Effluent Limitations and/or Monitoring	Other Relevant Factors
Chemical Constituents (Narrative WQO)	Monitoring for EC is required in the effluent and receiving water. Effluent monitoring trigger included.	Participation in the Salinity Control Program Alternative permitting approach.
Color (Narrative WQO)	Visual monitoring for discoloration is required in receiving water.	
Dissolved Oxygen (Numeric WQO)	No RP, tertiary treatment results in minimal DO impacts. Monitoring is required in the receiving water.	
Floating Material (Narrative WQO)	No RP due to tertiary treatment standards. Visual monitoring is required in receiving water.	
Oil and Grease (Narrative WQO)	No RP due to tertiary treatment standards. Visual monitoring of visible films, sheens, or coatings is required in the receiving water.	
pH (Numeric WQO)	No RP, but pH effluent limitations are included. Monitoring for pH is required in the effluent and receiving water.	
Pesticides (Narrative/Numeric WQO)	No RP for pesticides in the characterization monitoring list.	Quarterly priority pollutant characterization monitoring (effluent and upstream receiving water) from 1 August 2027 through 31 July 2028. Pyrethroid monitoring was conducted between 1 April 2022 and 31 March 2023 and resulted in no RP.
Radioactivity (Narrative/Numeric WQO)	No RP for radioactive constituents in the characterization monitoring list.	Quarterly priority pollutant characterization monitoring (effluent and upstream receiving water) from 1 August 2027 through 31 July 2028.
Suspended Sediments (Narrative WQO)	No RP based on effluent data, but Total Suspended Solids effluent limitation is included. Visual monitoring of suspended matter is required in the receiving water.	

Receiving Water Limitations Removed	Effluent Limitations and/or Monitoring	Other Relevant Factors
Settleable Substances (Narrative WQO)	No RP based on effluent data. Visual monitoring for bottom deposits is required in the receiving water.	
Suspended Material (Narrative WQO)	No RP based on effluent data, but Total Suspended Solids effluent limitation is included. Visual monitoring of suspended matter is required in the receiving water.	
Taste and Odors (Narrative WQO)	No RP due to tertiary treatment standards. Monitoring of potential nuisance conditions is required in the receiving water.	
Temperature (Numeric WQO)	No RP based on effluent data, temperature effluent limit included based on Thermal Plan objective. Monitoring for temperature is required in the effluent and receiving water.	
Toxicity (Narrative WQO)	RP for ammonia and seasonal ammonia effluent limits are included. Effluent monitoring for ammonia are included.	
Toxicity (Narrative WQO)	Chronic Whole Effluent Toxicity effluent limitations are included. Chronic toxicity effluent monitoring is included.	
Turbidity (Numeric WQO)	No effluent limitation due to Filtration System Operating Specifications. Monitoring for turbidity is required in the effluent and receiving water.	

B. Groundwater

1. The beneficial uses of the underlying groundwater are municipal and domestic supply, industrial service supply, industrial process supply, and agricultural supply. Groundwater limitations are required to protect the beneficial uses of the underlying groundwater.
2. **Rationale for Groundwater Limitations.** Groundwater limitations establish that the release of waste constituents from any portion of the Facility shall not cause or contribute to the exceedance of water quality objectives in the receiving water. If the Facility’s discharge contains waste at a level greater than a water quality objective but the groundwater receiving the waste remains

below the water quality objective, the limitation would not be violated. However, if the same discharge contains waste at a level greater than the water quality objective and causes the receiving water to exceed a water quality objective, the groundwater limitation would be violated. Similarly, if the same discharge contains waste above the water quality objective and the receiving water is above the objective, the Facility's discharge would be contributing to an exceedance of the water quality objective and would be violating the receiving water limitation, if the receiving water natural background concentration is less than the water quality objective. In the scenario where the level of waste in the Facility's discharge is below the water quality objective and the receiving water exceeds the water quality objective, the limitation would not be violated. Where natural background conditions exceed the water quality objective, compliance would be evaluated considering the established natural background concentration instead of the water quality objective. Only discharges causing or contributing to the exceedance of the water quality objective or natural background concentration (if greater than the water quality objective) in the groundwater would be in violation of the limitation.

The Basin Plan contains the following in Section 3 Water Quality Objectives, "The objectives contained in this plan, and any State or Federally promulgated objectives applicable to the basins covered by the plan, are intended to govern the levels of constituents and characteristics in the main water mass unless otherwise designated..." Any analysis of the above factors to determine exceedances of groundwater limitations would consider this and other guidance from the Basin Plan (e.g., hydrogeologic and background characterization studies, regional groundwater flow and dilution, etc.).

For natural background quality, the level of groundwater quality is dependent upon the background conditions. Historical data is not available to determine natural background conditions before any discharges from the Facility. Therefore, Central Valley Water Board staff rely on present-day sampling from upgradient monitoring locations to represent the range of water quality that otherwise would have been expected at the site before the Facility was operational. The Discharger conducted a groundwater characterization study of the City of Manteca and surrounding area, and submitted the findings on the 26 September 2006 Background Hydrogeologic Characterization Report conducted by Condor Earth Technologies, Inc. This report states "One well, BG-1 [MW-AW] has been installed to evaluate background water quality upgradient of the facility. This well is located in the regionally upgradient direction of the Facility (southeast). This well appears to be near the transition area where background groundwater flow from the southeast and ground water flow from the mounded groundwater under the Facility meet, especially during the irrigations season. Water quality at this well is, however, believed to be dominated by recharge from the regionally upgradient groundwater and from seasonal rainfall." Historical regional water quality data obtained by Department of Water Resources, U.S. EPA, and US Geological Survey from 23 monitoring wells located within a 33 square mile area is generally similar to results

obtained at the Discharger's background monitoring well MW-AW. Based on this information and findings contained in the report, the Central Valley Water Board concurs that MW-AW is appropriate to effectively and fully characterize the background groundwater quality conditions within the vicinity of the Facility and the agricultural fields.

The Discharger's Background Hydrogeologic Characterization Study also summarized all groundwater data collected to date and concluded that "groundwater quality under beneath and down gradient of the facility appear to be of poorer quality than upgradient groundwater for total dissolved solids, nitrate, and several of the trace metals." However, since this report, the Discharger has implemented several management practices (e.g., nitrification-denitrification facilities, biosolids now sent off-site for disposal, etc.). Thus, the Discharger cannot fully evaluate actual impacts on groundwater due to current land application practices without completion of additional studies. Nevertheless, this Order contains numeric and narrative land discharge specifications and reclamation specifications (WDR section IV), narrative and numeric groundwater limitations (WDR section V), Special Studies (WDR section VI.C), and monitoring and reporting requirements (Attachment E) to protect the quality of the underlying groundwater and the applicable uses. Additionally, this Order does not allow an increased volume of waste or an increase in wastewater discharge to land compared to the discharges allowed in Order R5-2021-0003.

The following provides rationale for the groundwater limits contained in this Order:

- a. Basin Plan water quality objectives include narrative objectives for chemical constituents, tastes and odors, and toxicity of groundwater. The toxicity objective requires that groundwater be maintained free of toxic substances in concentrations that produce detrimental physiological responses in humans, plants, animals, or aquatic life. The chemical constituent objective states groundwater shall not contain chemical constituents in concentrations that adversely affect any beneficial use. The tastes and odors objective prohibit taste- or odor-producing substances in concentrations that cause nuisance or adversely affect beneficial uses. The Basin Plan also establishes numerical water quality objectives for chemical constituents and radioactivity in groundwaters designated as municipal supply. These include, at a minimum, compliance with MCLs in Title 22 of the CCR. The bacteria objective prohibits coliform organisms at or above 2.2 MPN/100 mL. The Basin Plan requires the application of the most stringent objective necessary to ensure that waters do not contain chemical constituents, toxic substances, radionuclides, taste- or odor-producing substances, or bacteria in concentrations that adversely affect municipal or domestic supply, agricultural supply, industrial supply or some other beneficial use.

- b. **Salinity.** Total dissolved solids, which were found to be present in the groundwater at an average concentration range from 261 mg/L to 911 mg/L, have the potential to degrade groundwater quality at this site because there is little ability for attenuation in the shallow permeable vadose zone beneath this Facility. The Bay-Delta Plan provides applicable numeric water quality objectives for salinity in the San Joaquin River. With regard to groundwater, however, there are no numeric objectives. Therefore, the Discharger was required to conduct a site-specific salinity study in Order R5-2009-0095 to determine the appropriate total dissolved solids and electrical conductivity levels to protect the agricultural beneficial use in the vicinity of the Facility. Based on these requirements, in October 2012 the Discharger submitted a Site-Specific Salinity Objectives Study for the Protection of Groundwater Agricultural Uses Report. To determine the Site-Specific Salinity Objectives, the Discharger used the Hoffman exponential model, which was developed in 2010 to determine Salt tolerance of Crops in the Southern Sacramento-San Joaquin Delta Area. Soil type, crop evapotranspiration (depending on climate characteristics), soil water salinity (depending on salinity levels in irrigation water), and leaching fraction were the inputs included in the Hoffman model. Almonds were used as an example since they are heavily grown in the area of influence of the Facility and they are the most salt-sensitive crop. The model was run for conservative 0.10 and 0.15 leaching fractions, which likely results in deriving overly-protective salinity objectives for the irrigation water in the Facility area of influence where leaching fractions (L) are estimated to average 0.28. The precipitation conditions included in the model were: a) minimum rainfall of 4.2 in, which represents the driest conditions and b) median rainfall of 10.5 in, which represents a normal/above median precipitation. Based on the Hoffman-recommended model and an acceptable yield loss of 5% to almond crops, the proposed EC and TDS site-specific objectives for the protection of agricultural uses in the Facility area of influence ranges from 950 $\mu\text{mhos/cm}$ to 1,700 $\mu\text{mhos/cm}$ and 600 mg/L to 1,070 mg/L, respectively. These ranges are based on varying leaching fractions (L) and precipitation conditions described above. A groundwater limitation of 1,070 mg/L for TDS was established in Order R5-2015-0026 based on the site-specific objectives using a leaching fraction 0.15 and a median rainfall of 10.5, which represents typical conditions in the area of influence of the Facility.

The Discharger has selected the Alternative Permitting Approach of the Salinity Control Program which states, "Under Phase I of the Salt Control Program, permittees that are in compliance with the conditions for the Alternative Permitting Approach are in compliance with their salinity limits. For the purposes of this Program, salinity and its constituents include, and are limited to, the following: electrical conductivity, total dissolved solids, fixed dissolved solids, chloride, sulfate, and sodium" (pg. 84). This Order requires implementation of a Salinity Evaluation and Minimization Plan, participation in the Salinity P&O Study, and includes a performance-based

trigger for EC of 1,000 $\mu\text{mhos/cm}$, consistent with the Alternative Salinity Permitting Approach. The Discharger has been in compliance with the Alternative Permitting Approach; thus, the total dissolved solids groundwater limitations have not been retained from Order R5-2021-0003.

- c. **Nitrate.** Nitrate, which was found to be present in the groundwater at an average concentration range from 0.01 mg/L to 13.7 mg/L as nitrogen, has the potential to degrade groundwater quality because there is little ability for attenuation in the shallow permeable vadose zone beneath the Facility. Furthermore, groundwater monitoring data show nitrate concentrations above the Primary MCL of 10 mg/L in monitoring wells MW-3, MW-9W, and MW-11. The chemical constituents objective prohibits concentrations of chemical constituents in excess of California MCLs in groundwater that is designated as municipal or domestic supply. The California Primary MCL for nitrate is equivalent to 10 mg/L as nitrogen, and groundwater beneath the Facility is designated as municipal or domestic supply.

Overall, nitrate (as N) concentrations appear to be improving in the groundwater underlying the fields, though concentrations are still above the Primary MCL in some down-gradient wells and at or below the Primary MCL in the background well. The Facility has been upgraded to include nitrification/denitrification and land application area specifications are included to minimize nitrogen discharges to groundwater. This Order requires that the total nitrogen mass loading to the Land Application Areas shall not exceed the agronomic rate for the crop grown and the hydraulic loading rate shall also be at agronomic rates. The Discharger submits annual Nutrient Management Plans indicating that total nitrogen loadings are below agronomic rates and agronomic hydraulic loading rate at all times. Starting in the 2015 planting season, the Discharger switched to planting alfalfa, a year-round crop with stable water and nutrient demand throughout the year. The Discharger has also improved the operation efficiency of its water delivery system to the fields. As a result, nitrate (as N) concentrations have been steadily decreasing in the groundwater underlying the fields. Within continued improved operations, and an expected decrease in the acreage available for farming in the future, groundwater quality is expected to continue improving. This Order establishes groundwater nitrate limits based on the Primary MCL.

Lastly, the Nitrate Control Program is a prioritized program. The Facility is within Eastern San Joaquin Basin, which is a Priority 2 Basin. Notices to Comply were issued to dischargers in Priority 2 Basins in December 2023 and dischargers had until February 2025 to respond to the notice. These notices provided dischargers with a choice to participate in an individual permitting approach (Pathway A) or in a collective permitting approach (Pathway B). The Discharger submitted a Notice of Intent, dated 18 March 2021, indicating its intent to participate in the Pathway B Management Zone Permitting Approach for the Eastern San Joaquin Basin. Under this

approach, dischargers jointly form “Management Zones” that fulfill the requirements of the Nitrate Control Program.

- d. **pH.** pH, which ranged from 6.4 to 10.2 standard units in the secondary effluent storage pond and from 5.4 to 9.8 in the food processing wastewater, has the ability to degrade groundwater quality at this site because there is little potential for buffering in the shallow permeable vadose zone. According to Ayers and Westcot, pH less than 6.5 or greater than 8.4 can cause yield or vegetative growth reductions of sensitive crops if present in irrigation water, thereby impairing agricultural use of the water resource. The applicable water quality objective to protect the agricultural use from discharges of substances that affect pH is the narrative Chemical Constituents objective, which is applied following the “Policy of Application of Water Quality Objectives” in the Basin Plan. A numerical groundwater limitation range of 6.5 to 8.4 for pH, based on Ayers and Westcot, is relevant and appropriate to apply the narrative Chemical Constituents objective to protect unrestricted agricultural use of groundwater in the absence of information to support a less protective limit.

Groundwater pH ranged from 6.0 to 8.0. MW-9W was intermittently below 6.5 during the term of Order R5-2021-0003 while all other monitoring wells and the Secondary Effluent Storage Pond in the vicinity of MW-9W were within the range of 6.5 to 8.4 when MW-9W samples showed low pH. These intermittent pH fluctuations in MW-9W did not show a trend of worsening pH outside of the range of 6.5 to 8.4; therefore, pH groundwater limitations have not been retained from Order R5-2021-0003.

VI. RATIONALE FOR PROVISIONS

A. Standard Provisions

Standard Provisions, which apply to all NPDES permits in accordance with 40 C.F.R. section 122.41, and additional conditions applicable to specified categories of permits in accordance with 40 C.F.R. section 122.42, are provided in Attachment D. The discharger must comply with all standard provisions and with those additional conditions that are applicable under section 122.42.

Sections 122.41(a)(1) and (b) through (n) of 40 C.F.R. establish conditions that apply to all state issued NPDES permits. These conditions must be incorporated into the permits either expressly or by reference. If incorporated by reference, a specific citation to the regulations must be included in the Order. Section 123.25(a)(12) of 40 C.F.R. allows the state to omit or modify conditions to impose more stringent requirements. In accordance with 40 C.F.R. section 123.25, this Order omits federal conditions that address enforcement authority specified in 40 C.F.R. sections 122.41(j)(5) and (k)(2) because the enforcement authority under the Water Code is more stringent. In lieu of these conditions, this Order incorporates by reference Water Code section 13387(e).

B. Special Provisions

1. Reopener Provisions

- a. **Mercury.** The Delta Mercury Control Program was designed to proceed in two phases. Phase 1 is complete and Phase 1 Review is currently underway. Phase 2 begins after the Phase 1 Delta Mercury Control Program Review and Board approval. As a result of the Phase 1 Delta Mercury Control Program Review, changes may be needed to final allocations, implementation and monitoring requirements, and compliance schedules. Therefore, this Order may be reopened to address changes to the Delta Mercury Control Program.
- b. **Pollution Prevention.** This Order requires the Discharger prepare pollution prevention plans following Water Code section 13263.3(d)(3) for mercury. This reopener provision allows the Central Valley Water Board to reopen this Order for addition and/or modification of effluent limitations and requirements for these constituents based on a review of the pollution prevention plans.
- c. **Water Effects Ratio (WER) and Metal Translators.** A default WER of 1.0 has been used in this Order for calculating criteria for applicable inorganic constituents. In addition, default dissolved-to-total metal translators have been used to convert water quality objectives from dissolved to total. If the Discharger performs studies to determine site-specific WERs and/or site-specific dissolved-to-total metal translators, this Order may be reopened to modify the effluent limitations for the applicable inorganic constituents.
- d. **Ultraviolet Light (UV) Disinfection Operating Specifications.** UV system operating specifications are required to ensure that the UV system is operated to achieve the required pathogen removal. UV disinfection system specifications and monitoring and reporting requirements are required to ensure that adequate UV dosage is applied to the wastewater to inactivate pathogens (e.g., viruses) in the wastewater. UV dosage is dependent on several factors such as UV transmittance, UV power setting, wastewater turbidity, and wastewater flow through the UV disinfection system. The UV specifications in this Order are based on the National Water Research Institute (NWRI) and American Water Works Association Research Foundation (AWWRF) "Ultraviolet Disinfection Guidelines for Drinking Water and Water Reuse" first published in December 2000 and revised as a Third Edition dated August 2012 (NWRI guidelines). If the Discharger conducts a site-specific UV engineering study that identifies site-specific UV operating specifications that will achieve the virus inactivation required by Title 22 for disinfected tertiary recycled water, this Order may be reopened to modify the UV specifications, in accordance with Reopener Provision VI.C.1.e.

- e. **Central Valley Salinity Alternatives for Long-Term Sustainability (CV-SALTS).** On 17 January 2020, certain Basin Plan Amendments to incorporate new strategies for addressing ongoing salt and nitrate accumulation in the Central Valley became effective. Other provisions subject to U.S. EPA approval became effective on 2 November 2020, when approved by U.S. EPA. As the Central Valley Water Board moves forward to implement those provisions that are now in effect, this Order may be amended or modified to incorporate new or modified requirements necessary for implementation of the Basin Plan Amendments. More information regarding these Amendments can be found on the [Central Valley Salinity Alternatives for Long-Term Sustainability \(CV-SALTS\) web page](https://www.waterboards.ca.gov/centralvalley/water_issues/salinity/):
(https://www.waterboards.ca.gov/centralvalley/water_issues/salinity/)
- f. **Phase IV Stage 2 Improvements (17.5 MGD).** The Discharger has requested a total expansion of allowable flows to be discharged up to 17.5 MGD year-round to the San Joaquin River following completion of the Facility's IV stage 2 improvements. This provision requires the Discharger to meet certain conditions described in WDR section VI.C.1.h before an increase in discharge flow rate may be requested. Therefore, this Order may be reopened to modify the permitted average dry-weather flow.
- g. **Whole Effluent Toxicity.** This Order may be reopened for modification to revise the aquatic toxicity provisions if the Supreme Court determines that the test of significant toxicity cannot be used in NPDES permits and the State Water Board suspends or revises the aquatic toxicity water quality standards. See Fact Sheet Section III.C.1.c for more information.

If after review of new data and information, it is determined that the discharge has reasonable potential to cause or contribute to an instream exceedance of the Statewide Toxicity Provisions' numeric chronic aquatic toxicity objective and Basin Plan's narrative toxicity objective this Order may be reopened and effluent limitations added for acute and/or chronic toxicity.

- h. **Bay-Delta Plan.** On 25 February 2019, the California Office of Administrative Law approved the 2018 Bay-Delta Plan amendments, which include a numeric water quality objective (WQO) for the San Joaquin River at Vernalis of 1,000 µmhos/cm maximum, year-round, applied as a 30-day running average of mean daily electrical conductivity. Once approved by the United States Environmental Protection Agency (USEPA), the revised WQO will be applicable to the San Joaquin River at Vernalis. This Order may be amended or modified to implement the Bay-Delta Plan WQOs.
- i. **Mixing Zone/Dilution Credit Study for Ammonia.** The Discharger may conduct a mixing zone and dilution credit study in the San Joaquin River

for ammonia. This Order may be reopened to include information regarding a mixing zone and dilution credits study for ammonia and to revise effluent limitations for ammonia based on the results of the study.

2. Special Studies and Additional Monitoring Requirements

- a. **Toxicity Reduction Evaluation (TRE).** Pursuant to the Toxicity Provisions, the Discharger is required to initiate a TRE when any combination of two or more **MDEL or MMEL exceedances** occur within a single toxicity calendar month or within two successive toxicity calendar months. In addition, if other information indicates toxicity (e.g., results of additional monitoring, results of monitoring at a higher concentration than the IWC, fish kills, intermittent recurring toxicity), the Central Valley Water Board may require a TRE. A TRE may also be required when there is no effluent available to complete a routine monitoring test or **MMEL** compliance test. MRP Section V.G provides additional details regarding the TRE.

3. Best Management Practices and Pollution Prevention

- a. **Water Code section 13263.3(d)(3) Pollution Prevention Plans.** A pollution prevention plan for mercury is required in this Order per Water Code section 13263.3(d)(1)(C). The pollution prevention plans required in section VI.C.3.a of this Order, shall, at a minimum, meet the requirements outlined in Water Code section 13263.3(d)(3). The minimum requirements for the pollution prevention plans include the following:
 - i. An estimate of all of the sources of a pollutant contributing, or potentially contributing, to the loadings of a pollutant in the treatment plant influent.
 - ii. An analysis of the methods that could be used to prevent the discharge of the pollutants into the Facility, including application of local limits to industrial or commercial dischargers regarding pollution prevention techniques, public education and outreach, or other innovative and alternative approaches to reduce discharges of the pollutant to the Facility. The analysis also shall identify sources, or potential sources, not within the ability or authority of the Discharger to control, such as pollutants in the potable water supply, airborne pollutants, pharmaceuticals, or pesticides, and estimate the magnitude of those sources, to the extent feasible.
 - iii. An estimate of load reductions that may be attained through the methods identified in subparagraph ii.
 - iv. A plan for monitoring the results of the pollution prevention program.

- v. A description of the tasks, cost, and time required to investigate and implement various elements in the pollution prevention plan.
 - vi. A statement of the Discharger's pollution prevention goals and strategies, including priorities for short-term and long-term action, and a description of the Discharger's intended pollution prevention activities for the immediate future.
 - vii. A description of the Discharger's existing pollution prevention programs.
 - viii. An analysis, to the extent feasible, of any adverse environmental impacts, including cross-media impacts or substitute chemicals that may result from the implementation of the pollution prevention program.
 - ix. An analysis, to the extent feasible, of the costs and benefits that may be incurred to implement the pollution prevention program.
- b. **Salinity Evaluation and Minimization Plan (SEMP).** The Basin Plan includes a Salt Control Program for discharges to groundwater and surface water. The Salt Control Program is a phased approach to address salinity in the Central Valley Region. During Phase I the focus will be on conducting a Prioritization and Optimization (P&O) Study to provide information for subsequent phases of the Salt Control Program. During Phase I, the Salt Control Program includes two compliance pathways for dischargers to choose; a Conservative Salinity Permitting Approach and an Alternative Salinity Permitting Approach.

The Discharger submitted a notice to intent for the Salt Control Program on 18 May 2021 indicating its intent to meet the Alternative Salinity Permitting Approach. Under the Alternative Permitting Approach, the Basin Plan requires dischargers implement salinity minimization measures to maintain existing salinity levels and participate in the P&O Study. The Discharger's NOI demonstrated adequate participation in the P&O and this Order requires continued participation to meeting the requirements of the Alternative Salinity Permitting Approach. This Order also requires continued implementation of the Discharger's SEMP and includes a performance-based salinity trigger to ensure salinity levels do not increase. In accordance with the Basin Plan, the salinity trigger was developed based on existing facility performance and considers possible temporary increases that may occur due to water conservation and/or drought.

4. Construction, Operation, and Maintenance Specifications

- a. **Filtration System Operating Specifications.** Turbidity is included as an operational specification as an indicator of the effectiveness of the filtration

system for providing adequate disinfection. The tertiary treatment process utilized at this Facility is capable of reliably meeting a turbidity limitation of 2 NTU as a daily average. Failure of the treatment system such that virus removal is impaired would normally result in increased particles in the effluent, which result in higher effluent turbidity and could impact UV dosage. Turbidity has a major advantage for monitoring filter performance, allowing immediate detection of filter failure and rapid corrective action. The operational specification requires that turbidity prior to disinfection shall not exceed 2 NTU as a daily average; 5 NTU, more than 5 percent of the time within a 24-hour period, and an instantaneous maximum of 10 NTU.

- b. **UV Disinfection System Operating Specifications.** This Order requires that wastewater shall be oxidized, coagulated, filtered, and adequately disinfected pursuant to the DDW reclamation criteria, CCR, Title 22, division 4, chapter 3, (Title 22), or equivalent. To ensure that the UV disinfection system is operated to achieve the required pathogen removal, this Order includes effluent limits for total coliform organisms, filtration system operating specifications, and UV disinfection system operating specifications. Compliance with total coliform effluent limits alone does not ensure that pathogens in the municipal wastewater have been deactivated by the UV disinfection system. Compliance with the effluent limits and the filtration system and UV disinfection operating specifications demonstrates compliance with the equivalency to Title 22 disinfection requirement.

The NWRI guidelines include UV operating specifications for compliance with Title 22. For water recycling in accordance with Title 22, the UV system shall be an approved system included in the Treatment Technology Report for Recycled Water, December 2009 (or a later version, as applicable) published by the DDW. The UV system shall also conform to all requirements and operating specifications of the NWRI guidelines. A memorandum dated 1 November 2004 issued by DDW to Regional Water Board executive offices recommended that provisions be included in permits for water recycling treatment plants employing UV disinfection requiring dischargers to establish fixed cleaning frequency of lamp sleeves, as well as, include provisions that specify minimum delivered UV dose that must be maintained (per the NWRI Guidelines).

For granular media filtration, the NWRI Guidelines recommend a minimum hourly average UV dose of 100 mJ/cm². Therefore, this Order includes UV operating specifications requiring a minimum hourly average UV dose of 100 mJ/cm² and a minimum hourly average UV transmittance of 55%, per the NWRI Guidelines. If the Discharger conducts a site-specific UV engineering study that demonstrates a lower UV dose meets a Title 22 equivalent virus removal, this Order may be reopened to revise the UV operating specifications accordingly.

- c. **Treatment Pond Operating Specifications.** Three treatment or storage ponds are utilized within the Facility: 1) the food processing wastewater storage and treatment pond, 2) the secondary effluent equalization pond, and 3) the secondary effluent storage pond. The food processing wastewater storage/treatment pond and the secondary effluent equalization pond are lined, but the secondary effluent storage pond is not lined. The operation and maintenance specifications for these ponds in this Order are necessary to protect the public and the beneficial uses of the groundwater, and to prevent nuisance conditions.

The treatment pond operating requirements for pH in the Secondary Effluent Storage Pond have not been retained from Order R5-2021-0003 due to natural fluctuations of pH in the pond from sunlight, algal growth, and wildlife beyond the Discharger's control. The Secondary Effluent Storage Pond will continue to be operated as specified in WDR section VI.C.4.c and will not result in an increase in pollutants or any additional degradation of the receiving water.

5. Special Provisions for POTWs

a. Pretreatment Requirements

- i. The federal CWA section 307(b), and federal regulations, 40 C.F.R. part 403, require publicly owned treatment works to develop an acceptable industrial pretreatment program. A pretreatment program is required to prevent the introduction of pollutants, which will interfere with treatment plant operations or sludge disposal and prevent pass through of pollutants that exceed water quality objectives, standards or permit limitations. Pretreatment requirements are imposed pursuant to 40 C.F.R. part 403.
- ii. The Discharger shall implement and enforce its approved pretreatment program and is an enforceable condition of this Order. If the Discharger fails to perform the pretreatment functions, the Central Valley Water Board, the State Water Board or U.S. EPA may take enforcement actions against the Discharger as authorized by the CWA.

- b. **Sludge/Biosolids Treatment or Discharge Specifications.** Sludge in this Order means the solid, semisolid, and liquid residues removed during primary, secondary, or advanced wastewater treatment processes. Solid waste refers to grit and screening material generated during preliminary treatment. Residual sludge means sludge that will not be subject to further treatment at the wastewater treatment plant. Biosolids refer to sludge that has been treated and tested and shown to be capable of being beneficially and legally used pursuant to federal and state regulations as a soil amendment for agricultural, silvicultural, horticultural, and land reclamation activities as specified under 40 C.F.R. part 503. This Order does not regulate offsite use or disposal of biosolids, which are regulated instead

under 40 C.F.R. part 503; administered by U.S. EPA. The Sludge/Biosolids Treatment or Discharge Specifications in this Order implement the California Water Code to ensure sludge/biosolids are properly handled onsite to prevent nuisance, protect public health, and protect groundwater quality.

6. Other Special Provisions

- a. **Disinfection Requirements.** Consistent with previous Order R5-2021-0003, this Order requires wastewater to be oxidized, coagulated, filtered, and adequately disinfected consistent with DDW reclamation criteria, CCR, Title 22, division 4, chapter 3 (Title 22), or equivalent. The disinfection requirements are discussed in detail above in section IV.C.3, Determining the Need for WQBELs (see Pathogens).
- b. **CV-SALTS.** The Discharger shall comply with the applicable provisions of the Salt and Nitrate Control Programs adopted in Resolution R5-2018-0034 (as revised per Resolution R5-2020-0057) to address ongoing salt and nitrate accumulation in the Central Valley developed as part of the CV-SALTS initiative.
- c. **Discharge Flow Increase (12.87 MGD).** The Discharger has requested a total expansion of allowable flows to be discharged up to 12.87 MGD year-round to the San Joaquin River following completion of the Facility's IV stage 1 improvements. The Discharger must comply with each provision in section VI.C.6.c of this Order before the permitted effluent flow may be increased.

7. Compliance Schedules

This Order includes the compliance schedule for methylmercury previously included in Order R5-2021-0003. In general, an NPDES permit must include final effluent limitations that are consistent with CWA section 301 and with 40 C.F.R. section 122.44(d). There are exceptions to this general rule. The State Water Board's Resolution 2008-0025 "Policy for Compliance Schedules in National Pollutant Discharge Elimination System Permits" (Compliance Schedule Policy) allows compliance schedules for new, revised, or newly interpreted water quality objectives or criteria, or in accordance with a Total Maximum Daily Load (TMDL). All compliance schedules must be as short as possible, and may not exceed ten years from the effective date of the adoption, revision, or new interpretation of the applicable water quality objective or criterion, unless a TMDL allows a longer schedule. Where a compliance schedule for a final effluent limitation exceeds one year, the Order must include interim numeric effluent limitations for that constituent or parameter, interim requirements and dates toward achieving compliance, and compliance reporting within 14 days after each interim date. The Order may also include interim requirements to control the pollutant, such as pollutant minimization and source control measures.

In accordance with the Compliance Schedule Policy and 40 C.F.R. section 122.47, a discharger who seeks a compliance schedule must demonstrate additional time is necessary to implement actions to comply with a more stringent permit limitation. The Discharger must provide the following documentation as part of the application requirements:

- a. Diligent efforts have been made to quantify pollutant levels in the discharge and the sources of the pollutant in the waste stream, and the results of those efforts;
- b. Source control efforts are currently underway or completed, including compliance with any pollution prevention programs that have been established;
- c. A proposed schedule for additional source control measures or waste treatment;
- d. Data demonstrating current Facility performance to compare against existing permit effluent limits, as necessary to determine which is the more stringent interim, permit effluent limit to apply if a schedule of compliance is granted;
- e. The highest discharge quality that can reasonably be achieved until final compliance is attained;
- f. The proposed compliance schedule is as short as possible, given the type of facilities being constructed or programs being implemented, and industry experience with the time typically required to construct similar facilities or implement similar programs; and
- g. Additional information and analyses to be determined by the Regional Water Board on a case-by-case basis.

Based on information submitted with the ROWD, SMRs, and other miscellaneous submittals, it has been demonstrated to the satisfaction of the Central Valley Water Board that the Discharger needs time to implement actions to comply with the final effluent limitations for methylmercury.

The Delta Mercury Control Program is composed of two phases. Phase 1 is complete and Phase 1 Review is currently underway. Phase 1 emphasizes studies and pilot projects to develop and evaluate management practices to control methylmercury. Phase 1 includes provisions for: implementing pollution minimization programs and interim mass limits for inorganic (total) mercury point sources in the Delta and Yolo Bypass; controlling sediment-bound mercury in the Delta and Yolo Bypass that may become methylated in agricultural lands, wetlands, and open-water habitats; and reducing total mercury loading to the San Francisco Bay, as required by the *Water Quality*

Control Plan for the San Francisco Bay. As part of Phase 1, the CVCWA Coordinated Methylmercury Control Study Work Plan was approved by the Executive Officer on 7 November 2013. The final CVCWA Methylmercury Control Study was submitted to the Central Valley Water Board on 19 October 2018 and revised on 26 October 2018.

As part of Phase 1, the Delta Mercury Control Program also required dischargers to participate in a Mercury Exposure Reduction Program (MERP). The objective of the MERP is to reduce mercury exposure of Delta fish consumers most likely affected by mercury. The Discharger elected to provide financial support in a collective MERP with other Delta dischargers, rather than be individually responsible for any MERP activities. An exposure reduction work plan for Executive Officer approval was submitted on 20 October 2013, which addressed the MERP objective, elements, and the Discharger’s coordination with other stakeholders.

The Central Valley Water Board is conducting a Phase 1 Delta Mercury Control Program Review that considers: modification of methylmercury goals, objectives, allocations and/or the Final Compliance Date; implementation of management practices and schedules for methylmercury controls; and adoption of a mercury offset program for dischargers who cannot meet their load and WLAs after implementing all reasonable load reduction strategies. The review will also consider other potential public and environmental benefits and negative impacts (e.g., habitat restoration, flood protection, water supply, and fish consumption) of attaining the allocations. The fish tissue objectives, linkage analysis between objectives and sources, and the attainability of the allocations will be re-evaluated based on the findings of Phase 1 control studies and other information. The linkage analysis, fish tissue objectives, allocations, and time schedules shall be adjusted at the end of Phase 1, or subsequent program reviews, if appropriate.

Phase 2 begins after the Phase 1 Delta Mercury Control Program Review. During Phase 2, dischargers shall implement methylmercury control programs and continue inorganic (total) mercury reduction programs. Compliance monitoring and implementation of upstream control programs also shall occur in Phase 2. Any compliance schedule contained in an NPDES permit must be “...an enforceable sequence of actions or operations leading to compliance with an effluent limitation...” per the definition of a compliance schedule in CWA section 502(17). See also 40 C.F.R. section 122.2 (definition of schedule of compliance). The compliance schedule for methylmercury below meets these requirements:

Table F-14. Phase 1 Delta Mercury Control Program

Task	Date Due
i. Submit CVCWA Coordinated Methylmercury Control Study Work Plan	Complete (7 November 2013)

Task	Date Due
ii. Submit Pollution Prevention Plan (PPP) for Mercury (per WDR Section VI.C.3.a)	Complete (1 August 2014)
iii. Implement CVCWA Coordinated Methylmercury Control Study Work Plan	Complete
iv. Annual Progress Reports	See Technical Reports Table E-13
v. Submit CVCWA Coordinated Methylmercury Control Study Progress Report	Complete (20 October 2015)
vi. Submit Final CVCWA Coordinated Methylmercury Control Study	Complete (19 October 2018 and 26 October 2018)

Table F-14 Notes:

1. The PPP for Mercury shall be implemented in accordance with WDR Section VI.C.3.a.
2. Beginning 1 February 2025 and annually thereafter until the Facility achieves compliance with the final effluent limitations for methylmercury, the Discharger shall submit annual progress reports on the previously submitted pollution prevention plan for mercury. This annual report may be combined with the Annual Operations Report and submitted as one report. The progress reports shall discuss the effectiveness of the pollution prevention plan in the reduction of mercury in the discharge, include a summary of mercury and methylmercury monitoring results, and discuss updates to the pollution prevention plan.

Table F-15. Phase 2 Delta Mercury Control Program

Task	Date Due
vii. Implement methylmercury control programs	TBD
viii. Full Compliance	See Technical Reports Table E-13

Table F-15 Note:

1. To be determined. The Central Valley Water Board is conducting a Phase 1 Delta Mercury Control Program Review that considers: modification of methylmercury goals, objectives, allocations, final compliance date, etc. Consequently, the start of Phase 2 and the final compliance date is uncertain at the time this Order was adopted.

Federal regulations at 40 C.F.R. section 122.47(a)(1) require that, “Any schedules of compliance under this section shall require compliance as soon as possible...” The Compliance Schedule Policy also requires that compliance schedules are as short as possible and may not exceed 10 years, except when “...a permit limitation that implements or is consistent with the waste load allocations specified in a TMDL that is established through a Basin Plan amendment, provided that the TMDL implementation plan contains a compliance schedule or implementation schedule.” As discussed above, the Basin Plan’s Delta Mercury Control Program includes compliance schedule provisions and allows compliance with the WLAs for methylmercury by 2030. Until the Phase 1 Delta Mercury Control Program Review is complete, it is not possible to determine the appropriate compliance date for the Discharger that is as soon as possible. Therefore, this Order establishes a compliance

schedule for the final WQBELs for methylmercury with full compliance required by 31 December 2030, which is consistent with the Final Compliance Date of the TMDL. At completion of the Phase 1 Delta Mercury Control Program Review, the final compliance date for this compliance schedule will be re-evaluated to ensure compliance is required as soon as possible. Considering the available information, the compliance schedule is as short as possible in accordance with federal regulations and the Compliance Schedule Policy.

VII. RATIONALE FOR MONITORING AND REPORTING REQUIREMENTS

CWA section 308 and 40 C.F.R. sections 122.41(h), (j)-(l), 122.44(i), and 122.48 require that all NPDES permits specify monitoring and reporting requirements. Water Code sections 13267 and 13383 authorize the Central Valley Water Board to establish monitoring, inspection, entry, reporting, and recordkeeping requirements. The Monitoring and Reporting Program (MRP), Attachment E of this Order establishes monitoring, reporting, and recordkeeping requirements that implement federal and state requirements. The burden, including costs, of these monitoring and reporting requirements bears a reasonable relationship to the need for the reports and the benefits to be obtained therefrom. The Discharger, as owner and operator of the Facility, is required to comply with these requirements, which are necessary to determine compliance with this Order. The following provides additional rationale for the monitoring and reporting requirements contained in the MRP for this facility.

Water Code section 13176, subdivision (a), states: "The analysis of any material required by [Water Code sections 13000-16104] shall be performed by a laboratory that has accreditation or certification pursuant to Article 3 (commencing with section 100825) of Chapter 4 of Part 1 of Division 101 of the Health and Safety Code." The DDW accredits laboratories through its Environmental Laboratory Accreditation Program (ELAP).

Section 13176 cannot be interpreted in a manner that would violate federal holding time requirements that apply to NPDES permits pursuant to the CWA. (Wat. Code sections 13370, subd. (c), 13372, 13377.). Section 13176 is inapplicable to NPDES permits to the extent it is inconsistent with CWA requirements. (Wat. Code section 13372, subd. (a).) Lab accreditation is not required for field tests such as tests for color, odor, turbidity, pH, temperature, dissolved oxygen, electrical conductivity, and disinfectant residual. The holding time requirements are 15 minutes for chlorine, pH, DO, sulfite, temperature (40 C.F.R. section 136.3(e), Table II) The Discharger maintains an ELAP accredited laboratory on-site and conducts analysis within the required hold times.

A. Influent Monitoring

1. Influent monitoring is required to collect data on the characteristics of the wastewater and to assess compliance with effluent limitations (e.g., BOD₅ and TSS reduction requirements). The monitoring frequencies and sample types have been retained from Order R5-2021-0003, except as noted in Table F-16, below:

B. Effluent Monitoring

1. Pursuant to the requirements of 40 C.F.R. section 122.44(i)(2) effluent monitoring is required for all constituents with effluent limitations. Effluent monitoring is necessary to assess compliance with effluent limitations, assess the effectiveness of the treatment process, and to assess the impacts of the discharge on the receiving stream and groundwater. Effluent monitoring frequencies and sample types have been retained from Order R5-2021-0003, except as noted in Table F-16, below:

C. Receiving Water Monitoring

1. Surface Water

- a. **Delta Regional Monitoring Program.** The Central Valley Water Board requires individual dischargers and discharger groups to conduct monitoring of Delta waters and Delta tributary waters in the vicinity of their discharge, known as ambient (or receiving) water quality monitoring. This monitoring provides information on the impacts of waste discharges on Delta waters, and on the extant condition of the Delta waters. However, the equivalent funds spent on current monitoring efforts could be used more efficiently and productively and provide a better understanding of geographic and temporal distributions of contaminants and physical conditions in the Delta, and of other Delta water quality issues, if those funds were used for a coordinated ambient monitoring effort, rather than continue to be used in individual, uncoordinated ambient water quality monitoring programs. The Delta Regional Monitoring Program will provide data to better inform management and policy decisions regarding the Delta.

The Discharger is required to participate in the Delta Regional Monitoring Program. Delta Regional Monitoring Program data is not intended to be used directly to represent either upstream or downstream water quality for purposes of determining compliance with this Order. Delta Regional Monitoring Program monitoring stations are established generally as "integrator sites" to evaluate the combined impacts on water quality of multiple discharges into the Delta; Delta Regional Monitoring Program monitoring stations would not normally be able to identify the source of any specific constituent, but would be used to identify water quality issues needing further evaluation. Delta Regional Monitoring Program monitoring data may be used to help establish background receiving water quality for an RPA in an NPDES permit after evaluation of the applicability of the data for that purpose. In general, monitoring data from samples collected in the immediate vicinity of the discharge will be given greater weight in permitting decisions than receiving water monitoring data collected at greater distances from the discharge point. Delta Regional Monitoring Program data, as with all environmental monitoring data, can provide an assessment of water quality at a specific place and time that can be used

in conjunction with other information, such as other receiving water monitoring data, spatial and temporal distribution and trends of receiving water data, effluent data from the Discharger's discharge and other point and non-point source discharges, receiving water flow volume, speed and direction, and other information to determine the likely source or sources of a constituent that resulted in exceedance of a receiving water quality objective.

Participation in the Delta Regional Monitoring Program by a Discharger shall consist of providing funds and/or in-kind services to the Delta Regional Monitoring Program.

Since the Discharger is participating in the Delta Regional Monitoring Program, this Order does not require receiving water characterization monitoring for purposes of conducting the RPA. However, the ROWD for the next permit renewal shall include, at minimum, one representative ambient background characterization monitoring event for priority pollutant constituents during the term of the permit. Data from the Delta Regional Monitoring Program may be utilized to characterize the receiving water in the permit renewal. Alternatively, the Discharger may conduct any site-specific receiving water monitoring deemed appropriate by the Discharger and submit that monitoring data with the ROWD. In general, monitoring data from samples collected in the immediate vicinity of the discharge will be given greater weight in permitting decisions than receiving water monitoring data collected at greater distances from the discharge point. Historic receiving water monitoring data taken by the Discharger and from other sources may also be evaluated to determine whether or not that data is representative of current receiving water conditions. If found to be representative of current conditions, then that historic data may be used in characterizing receiving water quality for the purposes of the RPA.

- b. Receiving water monitoring is necessary to assess compliance with receiving water limitations and to assess the impacts of the discharge on the receiving stream. Receiving surface water monitoring frequencies and sample types have been retained from Order R5-2021-0003, except as noted in Table F-16, below:

2. Groundwater

- a. Water Code section 13267 states, in part, "(a) A Regional Water Board, in establishing waste discharge requirements may investigate the quality of any waters of the state within its region" and "(b)(1) In conducting an investigation, the Regional Water Board may require that any person who discharges waste that could affect the quality of waters within its region shall furnish, under penalty of perjury, technical or monitoring program reports which the Regional Water Board requires. The burden, including costs, of these reports shall bear a reasonable relationship to the need for the report and the benefits to be obtained from the reports." The burden,

including costs, of these reports shall bear a reasonable relationship to the need for the report and the benefits to be obtained from the reports. In requiring those reports, a Regional Water Board shall provide the person with a written explanation with regard to the need for the reports and shall identify the evidence that supports requiring that person to provide the reports. The Monitoring and Reporting Program is issued pursuant to Water Code section 13267. The groundwater monitoring and reporting program required by this Order and the Monitoring and Reporting Program are necessary to assure compliance with these waste discharge requirements. The Discharger is responsible for the discharges of waste at the facility subject to this Order.

- b. Monitoring of the groundwater must be conducted to determine if the discharge has caused an increase in constituent concentrations, when compared to background. The monitoring must, at a minimum, require a complete assessment of groundwater impacts including the vertical and lateral extent of degradation, an assessment of all wastewater-related constituents which may have migrated to groundwater, an analysis of whether additional or different methods of treatment or control of the discharge are necessary to provide BPTC to comply with the State Anti-Degradation Policy. Economic analysis is only one of many factors considered in determining BPTC. If monitoring indicates that the discharge has incrementally increased constituent concentrations in groundwater above background, this permit may be reopened and modified. Until groundwater monitoring is sufficient, this Order contains Groundwater Limitations that allow groundwater quality to be degraded for certain constituents when compared to background groundwater quality, but not to exceed water quality objectives. If groundwater quality has been degraded by the discharge, the incremental change in pollutant concentration (when compared with background) may not be increased. If groundwater quality has been or may be degraded by the discharge, this Order may be reopened, and specific numeric limitations established consistent with the State Anti-Degradation Policy and the Basin Plan.
- c. This Order requires the Discharger to continue groundwater monitoring and includes a regular schedule of groundwater monitoring in the attached Monitoring and Reporting Program. The groundwater monitoring reports are necessary to evaluate impacts to waters of the State to assure protection of beneficial uses and compliance with Central Valley Water Board plans and policies, including the State Anti-Degradation Policy. Evidence in the record includes effluent monitoring data that indicates the presence of constituents that may degrade groundwater and surface water.
- d. Groundwater monitoring frequencies and parameters have been retained from Order R5-2021-0003.

Table F-16. Summary of Monitoring Changes

Parameter, Units	Type of Monitoring	Prior Sample Frequency	Revised Sample Frequency	Reason for Change
Total Dissolved Solids	Influent	1/Month	Remove	Consistent with similar dischargers.
Acute Whole Effluent Toxicity	Effluent	1/Quarter	Remove	No RP.
Chronic Whole Effluent Toxicity	Effluent	1/Quarter	1/Month	Has RP.
Dieldrin	Effluent	None	1/Quarter	Has RP.
Hardness, Total (as CaCO ₃)	Effluent	1/Quarter	1/Month	Consistent with similar dischargers.
Nitrate Plus Nitrite (as N)	Effluent	1/Week	1/Month	Consistent with similar dischargers.
Total Coliform Organisms	Effluent	1/Day	3/Week	Consistent with similar dischargers.
Ammonia Nitrogen, Total (as N)	Receiving Water	1/Month for one year	Remove	Monitored for during effluent and receiving water characterization monitoring.
pH	Receiving Water	2/Month	1/Month	Consistent with similar dischargers.

D. Whole Effluent Toxicity Testing Requirements

Aquatic toxicity testing is necessary to evaluate the aggregate toxic effect of a mixture of toxicants in the effluent on the receiving water. Acute toxicity testing is conducted over a short time period and measures mortality, while chronic toxicity testing is conducted over a short or longer period and may measure mortality, reproduction, and growth. For this permit, aquatic toxicity testing is to be performed following methods identified in the Code of Federal Regulations, title 40, part 136, or other U.S. EPA-approved methods, or included in the following U.S. EPA method manuals: Short-term Methods for Estimating the Chronic Toxicity of Effluents and Receiving Waters to Freshwater Organisms, Fourth Edition (EPA-821-R-02-013).

Monthly chronic whole effluent toxicity testing is required to demonstrate compliance with the chronic toxicity effluent limitations/targets.

1. The discharge is subject to determination of “Pass” or “Fail” from a chronic toxicity test using the Test of Significant Toxicity (TST) statistical t-test approach described in *National Pollutant Discharge Elimination System Test of Significant Toxicity Implementation Document* (EPA 833-R-10-003, 2010), Appendix A, Figure A-1 and Table A-1 (Chronic Freshwater and East Coast Methods) and Appendix B, Table B-1.

2. The null hypothesis (Ho) for the TST statistical approach is:

Mean discharge IWC response \leq RMD x Mean control response, where the chronic RMD = 0.75.

A test result that rejects this null hypothesis is reported as "Pass." A test result that does not reject this null hypothesis is reported as "Fail."

3. The relative "Percent Effect" at the discharge IWC is defined and reported as:

Percent Effect = ((Mean control response – Mean discharge IWC response) / Mean control response) x 100.

This is a t-test (formally Student's t-Test), a statistical analysis comparing two sets of replicate observations, i.e., a control and IWC. The purpose of this statistical test is to determine if the means of the two sets of observations are different (i.e., if the IWC differs from the control, the test result is "Fail"). The Welch's t-test employed by the TST statistical approach is an adaptation of Student's t-test and is used with two samples having unequal variances.

4. **Sensitivity Screening.** The Discharger conducted an initial species sensitivity screening resulting in *Ceriodaphnia dubia* as the most sensitive species.

Under the Toxicity Provisions, the Discharger shall perform subsequent species sensitivity screening to re-evaluate the most sensitive species if the effluent used in the initial species sensitivity screening is no longer representative of the effluent or if a species sensitivity screening has not been performed in the last fifteen years. Subsequent species sensitivity screening may also be required prior to every order issuance, renewal or reopening, if reopening to address aquatic toxicity.

Pursuant to Section V.F of the MRP, the Discharger is required to perform species sensitivity screening **at least once every fifteen years or if the effluent used in the last species sensitivity screening is no longer representative of the effluent and the results of the most recent species sensitivity screening shall be submitted with the Report of Waste Discharge or other as appropriate.** Species sensitivity screening for chronic toxicity shall include, at a minimum, chronic WET testing four consecutive calendar quarters using the water flea (*Ceriodaphnia dubia*), fathead minnow (*Pimephales promelas*), and green algae (*Pseudokirchneriella subcapitata*). The tests shall be performed at an IWC of no less than 100 percent effluent and one control. For subsequent species sensitivity screening, if the first two species sensitivity screening events result in no change in the most sensitive species, the Discharger may cease the subsequent species sensitivity screening and the most sensitive species will remain unchanged.

The most sensitive species to be used for chronic toxicity testing was determined in accordance with the process outlined in the MRP section V.F. Based on the

Discharger's last 10 years of chronic toxicity data, there were results of "Fail" at the IWC using the TST statistical approach. The species that exhibited the highest percent effect was green algae (*Pseudokirchneriella subcapitata*) with a percent effect of 55.60; however, a subsequent compliance sample was performed and green algae did not result in a "Fail" at the IWC. Therefore, the species that exhibited the highest percent effect was water flea (*Ceriodaphnia dubia*, with a percent effect of 30.20 percent. Consequently, *Ceriodaphnia dubia* has been established as the most sensitive species for chronic WET testing.

5. **Toxicity Reduction Evaluation (TRE).** The Monitoring and Reporting Program of this Order requires chronic WET testing to demonstrate compliance with the numeric chronic toxicity effluent limitation. The Discharger is required to initiate a TRE when there is any combination of two or more chronic toxicity MDEL or MMEL violations within a single toxicity calendar month or within two successive toxicity calendar months has occurred. In addition, if other information indicates toxicity (e.g., results of additional monitoring, results of monitoring at a higher concentration than the IWC, fish kills, intermittent recurring toxicity), the Central Valley Water Board may require a TRE. A TRE may also be required when there is no effluent available to complete a routine monitoring test, MMET test, or MMEL compliance test.

E. Other Monitoring Requirements

1. Land Discharge Monitoring

Land discharge monitoring is required to ensure that the discharge to the land disposal area complies with the Land Discharge Specifications in WDR section IV.B.

2. Recycling Monitoring

Recycling monitoring and reporting are required to ensure compliance with the Title 22 Tertiary Recycling Specifications in WDR section IV.C and the accepted Title 22 Engineering report.

3. Biosolids Monitoring

Biosolids monitoring is required to ensure compliance with the pretreatment requirements contained in 40 C.F.R. part 403 and implemented in section VI.C.5.a. of this Order. Biosolids monitoring is required per U.S. EPA guidance to evaluate the effectiveness of the pretreatment program. Biosolids monitoring for compliance with 40 C.F.R. part 503 regulations is not included in this Order since it is a program administered by [U.S. EPA's part 503 Biosolids Program](https://www.epa.gov/biosolids/compliance-and-annual-biosolids-reporting) (<https://www.epa.gov/biosolids/compliance-and-annual-biosolids-reporting>)

4. Filtration System and UV Disinfection System Monitoring

Filtration system monitoring and reporting are required to determine compliance with the operation specifications for turbidity in Special Provisions section VI.C.4.a.

UV system monitoring and reporting are required to ensure that the UV system is operated to adequately inactivate pathogens in the wastewater. UV disinfection system monitoring is imposed to achieve equivalency to requirements established by the DDW, and the NWRI, Guidelines.

5. Treatment Pond Monitoring

Treatment pond monitoring is required to ensure proper operation of the storage pond and to ensure compliance with the pond operating requirements contained in the Special Provisions section VI.C.4.c, of this Order. Monitoring for pH at Monitoring Location PND-001 (Secondary Effluent Storage Pond) has not been retained from Order R5-2021-0003 because the pH groundwater monitoring in the vicinity of the Secondary Effluent Storage Pond did not exceed the range of 6.5-8.4 needed to protect the beneficial uses of the receiving water.

6. Pyrethroid Pesticides Monitoring

On 8 June 2017, the Central Valley Water Board adopted Resolution R5-2017-0057, which adopted the Basin Plan Amendment (BPA) for the Control of Pyrethroid Pesticide Discharges. Pyrethroid pesticides and toxicity monitoring was conducted by the Discharger between 1 April 2022 and 31 March 2023. Sampling did not result in an exceedance of the pyrethroid triggers. Therefore, pyrethroids pesticides monitoring has not been retained from Order R5-2021-0003.

7. Effluent and Receiving Water Characterization Monitoring

In accordance with section 1.3 of the SIP, periodic monitoring is required for priority pollutants for which criteria or objectives apply and for which no effluent limitations have been established. This Order requires quarterly effluent and one representative ambient background characterization monitoring event between 1 August 2027 and 31 July 2028 for priority pollutant constituents located in Appendix A to 40 C.F.R. part 423 during the term of the permit, in order to collect data to conduct an RPA for the next permit renewal.

8. Discharge Monitoring Report-Quality Assurance (DMR-QA) Study Program

Under the authority of section 308 of the CWA (33 U.S.C. section 1318), U.S. EPA requires all dischargers under the NPDES Program to participate in the annual DMR-QA Study Program. The DMR-QA Study evaluates the analytical ability of laboratories that routinely perform or support self-monitoring analyses required by NPDES permits. There are two options to satisfy the requirements of the DMR-QA Study Program: (1) The Discharger can obtain and analyze a

DMR-QA sample as part of the DMR-QA Study; or (2) Per the waiver issued by U.S.EPA to the State Water Board, the Discharger can submit the results of the most recent Water Pollution Performance Evaluation Study from their own laboratories or their contract laboratories. A Water Pollution Performance Evaluation Study is similar to the DMR-QA Study. Thus, it also evaluates a laboratory's ability to analyze wastewater samples to produce quality data that ensure the integrity of the NPDES Program. The Discharger shall submit annually the results of the DMR-QA Study or the results of the most recent Water Pollution Performance Evaluation Study to the State Water Board. The State Water Board's Quality Assurance Program Officer will send the DMR-QA Study results or the results of the most recent Water Pollution Performance Evaluation Study to U.S. EPA's DMR-QA Coordinator and Quality Assurance Manager.

VIII. PUBLIC PARTICIPATION

The Central Valley Water Board has considered the issuance of WDRs that will serve as an NPDES permit for <Facility Name>. As a step in the WDR adoption process, the Central Valley Water Board staff has developed tentative WDRs and has encouraged public participation in the WDR adoption process.

A. Notification of Interested Persons

The Central Valley Water Board notified the Discharger and interested agencies and persons of its intent to prescribe WDRs for the discharge and provided an opportunity to submit written comments and recommendations. Additionally, consistent with Water Code section 189.7, the Central Valley Water Board conducted outreach to potentially affected disadvantaged and/or tribal communities concerning tentative WDRs. Notification was provided through the following **<Describe Notification Process (e.g., posting of the Notice of Public Hearing (NOPH) at the Facility and name other locations if applicable)>**. Additionally, the NOPH was posted on the Central Valley Water Board's Tentative Orders webpage.

The public had access to the agenda and any changes in dates and locations through the [Central Valley Water Board's website](http://www.waterboards.ca.gov/centralvalley/board_info/meetings/) (http://www.waterboards.ca.gov/centralvalley/board_info/meetings/)

B. Written Comments

Interested persons were invited to submit written comments concerning tentative WDRs as provided through the notification process. Comments were due either in person or by mail to the Executive Office at the Central Valley Water Board at the address on the cover page of this Order.

To be fully responded to by staff and considered by the Central Valley Water Board, the written comments were due at the Central Valley Water Board office by 5:00 p.m. on **<Date>**.

C. Public Hearing

The Central Valley Water Board held a public hearing on the tentative WDRs during its regular Board meeting on the following date and time and at the following location:

Date: **3/4 June 2026**

Time: **8:30 a.m.**

Location: **Regional Water Quality Control Board, Central Valley Region
11020 Sun Center Dr., Suite #200
Rancho Cordova, CA 95670**

Physical Meeting Location w/ Remote Meeting Option

Interested persons were invited to attend. At the public hearing, the Central Valley Water Board heard testimony pertinent to the discharge, WDRs, and permit. For accuracy of the record, important testimony was requested in writing.

D. Reconsideration of Waste Discharge Requirements

Any person aggrieved by this action of the Central Valley Water Board may petition the State Water board to review the action in accordance with Water Code section 13320 and CCR, title 23, sections 2050 and following. The State Water Board must receive the petition by 5:00 p.m., within 30 calendar days of the date of adoption of this Order at the following address, except that if the thirtieth day following the date of this Order falls on a Saturday, Sunday, or state holiday, the petition must be received by the State Water Board by 5:00 p.m. on the next business day:

State Water Resources Control Board
Office of Chief Counsel
P.O. Box 100, 1001 I Street
Sacramento, CA 95812-0100

Or by email at waterqualitypetitions@waterboards.ca.gov

[Instructions on how to file a petition for review](http://www.waterboards.ca.gov/public_notices/petitions/water_quality/wqpetition_instructions.shtml)

(http://www.waterboards.ca.gov/public_notices/petitions/water_quality/wqpetition_instructions.shtml) are available on the Internet.

E. Information and Copying

The Report of Waste Discharge, other supporting documents, and comments received are on file and may be inspected at the address above at any time between 8:30 a.m. and 4:45 p.m., Monday through Friday. Copying of documents may be arranged through the Central Valley Water Board by calling (916) 464-3291.

F. Register of Interested Persons

Any person interested in being placed on the mailing list for information regarding the WDRs and NPDES permit should contact the Central Valley Water Board, reference this facility, and provide a name, address, and phone number.

G. Additional Information

Requests for additional information or questions regarding this order should be directed to Sarah Curry at 916-464-4713, or sarah.curry@waterboards.ca.gov.

ATTACHMENT G – SUMMARY OF REASONABLE POTENTIAL ANALYSIS

Constituent	Units	MEC	B	C	CMC	CCC	Water & Org	Org. Only	Basin Plan	MCL	Reasonable Potential
Ammonia (as N) 1 April – 30 November	mg/L	7.56	0.13	1.5	5.6	1.5	--	--	--	--	Yes
Ammonia (as N) 1 December – 31 March	mg/L	4.2	0.14	2.7	13	2.7	--	--	--	--	Yes
Dieldrin	ng/L	3.1	0.43	0.14	240	56	0.14	0.14	--	--	Yes
Nitrate Plus Nitrite	mg/L	11	1	10	--	--	--	--	--	10	Yes
Total Dissolved Solids	mg/L	524	364	500	--	--	--	--	--	500	No

Attachment G Table Notes:

1. All inorganic concentrations are given as a total concentration.
2. **Total Dissolved Solids.** Total dissolved solids does not have reasonable potential based on the critical downstream receiving water concentration (see section IV.C.3.b.i of the Fact Sheet).

Abbreviations used in this table:

- MEC = Maximum Effluent Concentration
 B = Maximum Receiving Water Concentration or lowest detection level, if non-detect
 C = Criterion used for Reasonable Potential Analysis
 CMC = Criterion Maximum Concentration (CTR or NTR)
 CCC = Criterion Continuous Concentration (CTR or NTR)
 Water & Org = Human Health Criterion for Consumption of Water & Organisms (CTR or NTR)
 Org Only = Human Health Criterion for Consumption of Organisms Only (CTR or NTR)
 Basin Plan = Numeric Site-Specific Basin Plan Water Quality Objective
 MCL = Drinking Water Standards Maximum Contaminant Level
 NA = Not Available
 ND = Non-detect

ATTACHMENT H – CALCULATION OF WQBELS

TABLE H-1. HUMAN HEALTH WQBELS CALCULATIONS

Parameter	Units	Criteria	Mean Background Concentration	Effluent CV	Dilution Factor	MDEL/AMEL Multiplier	AWEL/AMEL Multiplier	AMEL	MDEL	AWEL
Dieldrin	ng/L	0.14	0.35	0.93	--	2.4	--	0.14	0.34	--
Nitrate Plus Nitrite, Total (as N)	mg/L	10	0.67	1.0	--	--	2.0	10	--	20

Table H-1 Notes:

- CV was established according to section 1.4 of the SIP.

Abbreviations used in this table:

CV = Coefficient of Variation
MDEL = Maximum Daily Effluent Limitation
AMEL = Average Monthly Effluent Limitation
MDEL = Maximum Daily Effluent Limitation
AWEL = Average Weekly Effluent Limitation

TABLE H-2. AQUATIC LIFE WQBELS CALCULATIONS

Parameter	Units	CMC Criteria	CCC Criteria	B	Effluent CV	CMC Dilution Factor	CCC Dilution Factor	ECA Multiplier _{acute}	LTA _{acute}	ECA Multiplier _{chronic}	LTA _{chronic}	AMEL Multiplier ₉₅	AWEL Multiplier	MDEL Multiplier ₉₉	AMEL	AWEL	MDEL
Ammonia (as N) 1 April – 30 November	mg/L	5.6	1.5	0.35	1.9	--	--	0.12	0.68	0.48	0.70	2.7	6.0	--	2.4	4.0	--
Ammonia (as N) 1 December – 31 March	mg/L	13	2.7	0.13	0.98	--	--	0.21	2.8	0.67	1.8	1.3	3.9	--	2.4	6.9	--

Table H-2 Notes:

1. AMEL calculated according to section 1.4 of the SIP using a 95th percentile occurrence probability.
2. AWEL calculated according to section 1.4 of the SIP using a 98th percentile occurrence probability.
3. MDEL calculated according to section 1.4 of the SIP using a 99th percentile occurrence probability.
4. **Ammonia.** Seasonal effluent limitations have been established for ammonia (see Fact Sheet section IV.C.3.c.i).

Abbreviations used in this table:

- B = Maximum Receiving Water Concentration or lowest detection level, if non-detect
- CMC = Criterion Maximum Concentration (CTR or NTR)
- CCC = Criterion Continuous Concentration (CTR or NTR)
- CV = Coefficient of Variation (established in accordance with section 1.4 of the SIP)
- ECA = Effluent Concentration Allowance
- LTA = Aquatic Life Calculations – Long-Term Average
- MDEL = Maximum Daily Effluent Limitation
- AMEL = Average Monthly Effluent Limitation
- MDEL = Maximum Daily Effluent Limitation
- AWEL = Average Weekly Effluent Limitation