

North Coast Regional Water Quality Control Board

ORDER NO. R1-2021-0002

NPDES NO. CA0024058

WDID NO. 1B820450SON

**(Revised in accordance with Amendment Order No. R1-2024-0030
on December 5, 2024)**

WASTE DISCHARGE REQUIREMENTS AND MASTER RECYCLING PERMIT

The following Permittee is subject to waste discharge requirements (WDRs) set forth in this Order:

Permittee: **Russian River County Sanitation District and Sonoma Water**

Name of Facility: **Russian River Wastewater Treatment Facility**

Facility Address: **18400 Neely Road
Guerneville, CA 95446
Sonoma County**

Table 1. Discharge Location

Discharge Point	Effluent Description	Discharge Point Latitude (North-South)	Discharge Point Longitude (East-West)	Receiving Water
001	Disinfected Tertiary Treated Wastewater	38° 29' 07"	122° 59' 54"	Effluent Storage Pond
002	Disinfected Tertiary Treated Wastewater	38° 28' 56"	123° 00' 00"	Russian River

Discharge Point	Effluent Description	Discharge Point Latitude (North-South)	Discharge Point Longitude (East-West)	Receiving Water
003	Disinfected Tertiary Treated Wastewater	38° 29' 01" 38° 29' 12"	122° 59' 53" 122° 59' 49"	Land Disposal/Irrigation Upper and Lower Burch property
004	Disinfected Tertiary Recycled Water	38° 28' 42"	122° 59' 41"	Recycling/Irrigation Northwood Golf Course
005	Disinfected Tertiary Treated Wastewater	38° 28' 56"	123° 00' 00"	Russian River

This Order was adopted on:

June 17, 2021

This Order shall become effective on:

August 1, 2021

This Order shall expire on:

July 31, 2026

The Permittee shall file a Report of Waste Discharge as an application for reissuance of WDRs in accordance with title 23, California Code of Regulations, and an application for reissuance of a National Pollutant Discharge Elimination System (NPDES) permit no later than: **August 1, 2025**. The U.S. Environmental Protection Agency (U.S. EPA) and the California Regional Water Quality Control Board North Coast Region have classified this discharge as follows: **“Minor”**

I, Matthias St. John, Executive Officer, do hereby certify that this Order with all attachments is a full, true, and correct copy of the Order adopted by the California Regional Water Quality Control Board, North Coast Region, on June 17, 2021.

Valerie Quinto, Executive Officer

21_0002_Russian River CSD and Sonoma Water WWTF_NPDES

TABLE OF CONTENTS

1. Facility Information	5
2. Findings.....	5
2.1. Legal Authorities.....	5
2.2. Background and Rationale for Requirements.....	5
2.3. Provisions and Requirements Implementing State Law.....	5
2.4. Notification of Interested Parties.....	6
2.5. Consideration of Public Comment.....	6
3. Discharge Prohibitions	6
4. Effluent Limitations and Discharge specifications	8
4.1. Effluent Limitations – Discharge Points 001, 002, and 005	8
4.2. Land Discharge Specifications – Discharge Point 003	10
4.3. Recycling Specifications and Requirements – Discharge Point 004.....	13
4.4. Other Requirements	15
5. Receiving Water Limitations.....	18
5.1. Surface Water Limitations	19
5.2. Groundwater Limitations.....	21
6. Provisions.....	22
6.1. Standard Provisions	22
6.2. Monitoring and Reporting Program (MRP) Requirements.....	23
6.3. Special Provisions	23
7. Compliance Determination	35

TABLE OF TABLES

Table 1. Discharge Location.....	1
Table 2. Effluent Limitations – Discharge Point 001 (Monitoring Location EFF-001).....	8
Table 3. Effluent Limitations – Discharge Points 002 and 005 (Monitoring Locations EFF-002 and EFF-005).....	9
Table 4. Land Discharge Specifications – Discharge Point 003 (Monitoring Location LND-001).....	11
Table 5. Recycled Water Discharge Specifications – Discharge Point 004 (Monitoring Location REC-001).....	13

TABLE OF ATTACHMENTS

Attachment A - Definitions.....A-1
Attachment B - Maps.....B-1
Attachment C - Flow Schematic C-1
Attachment D - Standard Provisions D-1
Attachment E - Monitoring and Reporting Program.....E-1
Attachment F - Fact Sheet F-1
Attachment G - Recycled Water Findings, Use Requirements, Provisions, and Technical
Report Requirements.....G-1

1. FACILITY INFORMATION

Information describing the Russian River County Sanitation District and Sonoma Water (Permittee) Russian River Wastewater Treatment Facility (Facility) is summarized in sections 1 and 2 of the Fact Sheet (Attachment F). Section 1 of the Fact Sheet also includes information regarding the Facility's permit application.

2. FINDINGS

The California Regional Water Quality Control Board, North Coast Region (Regional Water Board), finds:

2.1. Legal Authorities.

This Order is issued pursuant to section 402 of the federal Clean Water Act (CWA) and implementing regulations adopted by the U.S. Environmental Protection Agency (U.S. EPA) and chapter 5.5, division 7 of the California Water Code (commencing with section 13370). It shall serve as a NPDES permit authorizing the Permittee to discharge into waters of the United States at the discharge location described in Table 1 subject to the Waste Discharge Requirements (WDRs) and a master recycling permit pursuant to article 4, chapter 7, division 7 of the Water Code (commencing with section 13500). This Order also serves as WDRs pursuant to article 4, chapter 4, division 7 of the Water Code (commencing with section 13260).

2.2. Background and Rationale for Requirements.

The Regional Water Board developed the requirements in this Order based on information submitted as part of the Permittee's application, monitoring and reporting programs, and other available information. The Fact Sheet (Attachment F) contains background information and rationale for the requirements in this Order and is hereby incorporated into this Order and constitutes Findings for this Order. Attachments A through E and Attachment G are also incorporated into this Order.

2.3. Provisions and Requirements Implementing State Law.

The provisions/requirements in subsections 3.5, 3.6, 4.2, 4.3, 5.2, 6.3.1.7, 6.3.1.8, 6.3.2.1, 6.3.5.1, and 6.3.5.4 of this Order and sections 6, 7, 8.3, 10.4.2.10, 10.4.2.11, 10.4.3, 10.4.4, 10.5.3 and 10.5.4 of the MRP are included to implement state law only. These provisions/requirements are not required or authorized under the federal CWA; consequently, violations of these provisions/requirements are not subject to the enforcement remedies that are available for NPDES violations.

2.4. Notification of Interested Parties.

The Regional Water Board has notified the Permittee and interested agencies and persons of its intent to prescribe WDRs for the discharge and has provided them with an opportunity to submit their written comments and recommendations. Details of the notification are provided in the Fact Sheet.

2.5. Consideration of Public Comment.

The Regional Water Board, in a public meeting, heard and considered all comments pertaining to the discharge. Details of the Public Hearing are provided in the Fact Sheet.

THEREFORE, IT IS HEREBY ORDERED, that Waste Discharge Requirements (WDR) and Master Recycling Permit Order No. R1-2014-0002 and Monitoring and Reporting Program (MRP) No. R1-2014-0002, are rescinded upon the effective date of this Order except for enforcement purposes, and in order to meet the provisions contained in division 7 of the California Water Code (Water Code) (commencing with section 13000) and regulations and guidelines adopted thereunder, and the provisions of the federal Clean Water Act (CWA) and regulations and guidelines adopted thereunder, the Permittee shall comply with the requirements of this Order. This action in no way prevents the North Coast Regional Water Board from taking enforcement action for past violations of the previous permit.

3. DISCHARGE PROHIBITIONS

- 3.1. The discharge of any waste not disclosed by the Permittee or not within the reasonable contemplation of the Regional Water Board is prohibited.
- 3.2. Creation of pollution, contamination, or nuisance, as defined by section 13050 of the Water Code is prohibited.
- 3.3. The discharge of sludge or digester supernatant is prohibited, except as authorized under section 6.3.5.3 of this Order (Sludge Disposal and Handling Requirements).
- 3.4. The discharge or recycling use of untreated or partially treated waste (receiving a lower level of treatment than described in section 2.1 of the Fact Sheet) from anywhere within the collection, treatment, or disposal systems is prohibited, except as provided for in section 4.4.1.4 (Filtration Process Requirements) and in Attachment D, Standard Provisions 1.7 (Bypass) and 1.8 (Upset).

- 3.5. Any sanitary sewer overflow (SSO) that results in a discharge of untreated or partially treated wastewater to (a) waters of the state or (b) land that creates pollution, contamination, or nuisance, as defined in Water Code section 13050(m) is prohibited.
- 3.6. The discharge of waste to land that is not owned by the Permittee, governed by District ordinance, or under agreement to use by the Permittee, or for which the Permittee has explicitly permitted such use, is prohibited, except for use for fire suppression as provided in title 22, sections 60307(a) and 60307(b) of the California Code of Regulations (CCR).
- 3.7. The discharge of waste at any point not described in Table 1 and Finding 2.2 of the Fact Sheet or authorized by a permit issued by the State Water Resources Control Board (State Water Board) or another Regional Water Board is prohibited.
- 3.8. The average dry weather flow (ADWF) of waste through the Facility shall not exceed 0.51 million gallons per day (mgd), measured daily and averaged over a calendar month, unless the Permittee demonstrates that it has storage and recycled water capacity to handle a higher ADWF, not to exceed 0.71 mgd. The peak daily wet weather flow of waste through the tertiary wastewater treatment and disinfection system shall not exceed 3.5 mgd, measured daily. Compliance with this prohibition shall be determined as defined in sections 7.11 and 7.12 of this Order.
- 3.9. The discharge of waste to the Russian River and its tributaries is prohibited during the period from May 15 through September 30 of each year.
- 3.10. During the period from October 1 through May 14, discharges of disinfected tertiary treated wastewater to the Russian River shall not exceed one percent of the flow of the Russian River, as measured at United States Geological Survey (USGS) Gauge No. 11-4670.00 at Hacienda Bridge. For the purposes of this Order, compliance with this discharge prohibition shall be determined as follows:
 - 3.10.1. The discharge of disinfected tertiary treated wastewater shall be adjusted at least once daily to avoid exceeding, to the extent practicable, one percent of the most recent daily flow measurement of the Russian River at USGS Gauge No. 11-4670.00. Daily flow shall be based on flow meter comparisons reasonably read between the hours of 12:01 am and 12:00 midnight; and,
 - 3.10.2. In no case shall the total volume of disinfected tertiary treated wastewater discharged in a calendar month exceed one percent of the total volume of the Russian River measured at USGS Gauge No. 11-4670.00 in the same calendar month. At the beginning of the discharge season, the monthly flow volume comparisons shall be based on the date when the discharge commenced to the

end of the calendar month. At the end of the discharge season, the monthly flow volume comparisons shall be based on the first day of the calendar month to the date when the discharge ceased for the season.

- 3.11. The discharge of any radiological, chemical, or biological warfare agent into waters of the state is prohibited under Water Code section 13375.
- 3.12. The acceptance of septage to a location other than an approved septage receiving station and in accordance with a septage management program approved by the Regional Water Board Executive Officer is prohibited.

4. EFFLUENT LIMITATIONS AND DISCHARGE SPECIFICATIONS

4.1. Effluent Limitations – Discharge Points 001, 002, and 005

4.1.1. Final Effluent Limitations – Discharge Point 001

- 4.1.1.1. The discharge of treated wastewater shall maintain compliance with the following effluent limitations at Discharge Point 001, with compliance measured at Monitoring Location EFF-001 as described in the MRP (Attachment E). The tertiary treated wastewater shall be adequately oxidized, filtered, and disinfected as defined in title 22, division 4, chapter 3, of the CCR.

Table 2. Effluent Limitations – Discharge Point 001 (Monitoring Location EFF-001)

Parameter	Units	Average Monthly ¹	Average Weekly ¹	Maximum Daily ¹	Instantaneous Minimum ¹	Instantaneous Maximum ¹
Biochemical Oxygen Demand 5-day @ 20°C (BOD ₅)	mg/L	10	15	--	--	--
Total Suspended Solids (TSS)	mg/L	10	15	--	--	--
pH	standard units	--	--	--	6.0	9.0

Table Notes:

- 1. See Definitions in Attachment A and Compliance Determination discussion in section 7 of this Order.

4.1.1.2. **Percent Removal:** The average monthly percent removal of BOD₅ and TSS shall not be less than 85 percent. Percent removal shall be determined from the monthly average value of influent wastewater concentration in comparison to the monthly average value of effluent concentration for the same constituent over the same time period as measured at Monitoring Locations INF-001 and EFF-001, respectively.

4.1.1.3. **Disinfection.** Disinfected effluent discharged from the Facility through Discharge Point 001 during periods of discharge to the Russian River at Discharge Point 002 shall not contain total coliform bacteria exceeding the following concentrations, as measured at Monitoring Location EFF-001:

4.1.1.3.1. The median concentration of the disinfection channels shall not exceed a Most Probable Number (MPN) of 2.2 per 100 milliliters (mL) using the daily bacteriological results¹ of the last 7 days for which analyses have been completed²;

4.1.1.3.2. The number of coliform bacteria shall not exceed an MPN of 23 per 100 mL in more than one sample in any 30-day period; and

4.1.1.3.3. No sample shall exceed an MPN of 240 total coliform bacteria per 100 mL.

4.1.2. Final Effluent Limitations – Discharge Points 002 and 005

4.1.2.1. The discharge of treated wastewater shall maintain compliance with the following effluent limitations at Discharge Points 002 and 005 during periods of discharge to the Russian River, with compliance measured at Monitoring Locations EFF-002 and EFF-005 as described in the MRP (Attachment E).

Table 3. Effluent Limitations – Discharge Points 002 and 005 (Monitoring Locations EFF-002 and EFF-005)

Parameter ¹	Units	Average Monthly ²	Maximum Daily ²	Instantaneous Minimum ²	Instantaneous Maximum ²
pH	standard units	--	--	6.5	8.5

¹ All operating channels shall be sampled. The daily result is the highest channel result when multiple channels are operating.

² See Compliance Determination section 7.8 of this Order regarding compliance with bacteriological effluent limitations.

Parameter ¹	Units	Average Monthly ²	Maximum Daily ²	Instantaneous Minimum ²	Instantaneous Maximum ²
Aluminum, Total Recoverable	µg/L	200	606	--	--

Table Notes:

1. In the event of a direct discharge to the Russian River, BOD₅ and TSS effluent limitations in Table 2 and total coliform effluent limitations in section 4.1.1.3 apply at Discharge Point 002.
2. See Definitions in Attachment A and Compliance Determination discussion in section 7 of this Order.

4.1.2.2. **Acute Toxicity.** There shall be no acute toxicity in treated wastewater discharged to the Russian River. The Permittee will be considered in compliance with this limitation when the survival of aquatic organisms in a 96-hour bioassay of undiluted effluent complies with the following:

4.1.2.2.1. Minimum for any one bioassay: 70 percent survival; and

4.1.2.2.2. Median for the three most recent consecutive bioassays: at least 90 percent survival.

Compliance with this effluent limitation shall be determined in accordance with section 7.9 of this Order and section 5.1 of the MRP (Attachment E).

4.1.3. **Interim Effluent Limitations – Not Applicable**

This Order does not establish interim effluent limitations or schedules for compliance with final limitations.

4.2. **Land Discharge Specifications – Discharge Point 003**

4.2.1. **Final Discharge Specifications – Discharge Point 003**

4.2.1.1. The discharge of treated wastewater shall maintain compliance with the following discharge specifications at Discharge Point 003 during periods of discharge to the land disposal areas, with compliance measured at Monitoring Location LND-001 as described in the MRP (Attachment E).

Table 4. Land Discharge Specifications — Discharge Point 003 (Monitoring Location LND-001)

Parameter ¹	Units	Average Monthly ²	Maximum Daily ²	Instantaneous Minimum ²	Instantaneous Maximum ²
pH	standard units	-	-	6.0	9.0
Nitrate Nitrogen, Total (as N)	mg/L	10	20	-	-
Sodium	mg/L	60	--	--	--
Aluminum, Total Recoverable	mg/L	1.0	--	--	--

Table Notes:

1. In the event of a direct discharge to the Burch Property, BOD₅, TSS, and pH effluent limitations in Table 2 and total coliform effluent limitations in section 4.1.1.3 apply at Discharge Point 003.
2. See Definitions in Attachment A and Compliance Determination discussion in section 7 of this Order.

4.2.2. Land Discharge Requirements

- 4.2.2.1. The Permittee shall submit a Land Discharge/Recycled Water Operations and Management Plan as required by section 6.3.2.1 of this Order.
- 4.2.2.2. The Permittee shall install, operate, and maintain the forest irrigation system in a manner that ensures compliance with all requirements of this Order.
- 4.2.2.3. The Permittee shall conduct periodic inspections of the irrigation system, facilities, and operations to monitor and ensure compliance with the conditions of this Order.
- 4.2.2.4. The Permittee shall operate the forest irrigation system in a manner that minimizes the potential for runoff. The Regional Water Board recognizes that even with diligent implementation of best management practices (BMPs), incidental runoff events may occur on occasion. Incidental runoff is defined as unintended small amounts of runoff from irrigation areas where appropriate irrigation rates and BMPs are being implemented. Examples of incidental runoff include unintended, minimal over-spray from sprinklers that escapes the irrigation area or accidental breakage of a sprinkler head on a properly maintained irrigation system.

Water leaving an irrigation area is not considered incidental if it is part of the facility design, if it is due to excessive application, if it is due to intentional overflow or application, or if it is due to negligence. Incidental runoff events are typically infrequent, low volume, accidental, not due to a pattern of neglect or lack of oversight and are promptly addressed.

- 4.2.2.5. The use of disinfected tertiary effluent for forest irrigation shall not cause or contribute to an exceedance of any applicable water quality standard. The Permittee shall be responsible for ensuring that all discharges to the forest irrigation system meet all terms and conditions of this Order, including the quality standards in section 4.1 and 4.2.1 of this Order.
- 4.2.2.6. Disinfected tertiary effluent shall not be irrigated within 50 feet of any domestic water supply well.
- 4.2.2.7. The use of disinfected tertiary effluent for irrigation shall not cause degradation of any water supply.
- 4.2.2.8. Irrigation areas shall be managed to minimize ponding and conditions conducive to the proliferation of mosquitoes and other disease vectors, and to avoid creation of a public nuisance or health hazard. The following practices shall be implemented, at a minimum:
 - 4.2.2.8.1. Irrigation water shall infiltrate completely within a 48-hour period; and
 - 4.2.2.8.2. Low-pressure and unpressurized pipelines and ditches that may be accessible to mosquitoes shall not be used to store effluent.
- 4.2.2.9. Treated effluent used for irrigation shall not be allowed to escape the use areas in the form of surface runoff. Where appropriate, practices and strategies to prevent the occurrence of runoff shall include, but not be limited to:
 - 4.2.2.9.1. A minimum 50-foot setback to all surface waters or implementation of BMPs designed to prevent the potential for runoff discharging to surface water;
 - 4.2.2.9.2. Proper design and aim of sprinkler heads;
 - 4.2.2.9.3. Proper design and operation of the irrigation system;
 - 4.2.2.9.4. Refraining from application during precipitation events; and
 - 4.2.2.9.5. Maintenance of irrigation infrastructure (e.g., pipelines, pumps, etc.) to prevent and minimize breakage and leaks.

- 4.2.2.10. All irrigation equipment, pumps, piping, valves, quick couplers and outlets shall be a type or secured in a manner that only permits operation by authorized personnel and shall be appropriately marked to differentiate them from potable facilities.
- 4.2.2.11. The main shutoff valve of the irrigation system meter shall be tagged with a warning sign indicating the use of treated wastewater effluent. The valve shall be equipped with an appropriate locking device to prevent unauthorized operation of the valve.

4.3. Recycling Specifications and Requirements – Discharge Point 004

4.3.1. Water Recycling Specifications

- 4.3.1.1. When discharging to the recycled water system, the Permittee shall maintain compliance with the following discharge specifications at Discharge Point 004, with compliance measured at Monitoring Location REC-001, as described in the attached MRP (Attachment E), unless otherwise specified.

**Table 5. Recycled Water Discharge Specifications – Discharge Point 004
 (Monitoring Location REC-001)**

Parameter ¹	Units	Average Monthly ²	Maximum Daily ²	Instantaneous Minimum ²	Instantaneous Maximum ²
Nitrate Nitrogen, Total (as N)	mg/L	10	20	-	-

Table Notes:

1. In the event that recycled water is transferred directly from the treatment plant to the Northwood Golf Course (bypassing effluent storage pond), BOD₅, TSS, and pH effluent limitations in Table 2 and total coliform bacteria effluent limitations in section 4.1.1.3 apply at Discharge Point 004.
2. See Definitions in Attachment A and Compliance Determination discussion in section 7 of this Order.

- 4.3.1.2. **Disinfection.** Disinfected effluent discharged from the Facility through Discharge Point 004 during periods of discharge to the recycled water system at REC-001 shall not contain total coliform bacteria exceeding the following concentrations, as measured at Monitoring Location EFF-001:

- 4.3.1.2.1. The median concentration shall not exceed an MPN of 2.2 per 100 mL, using the bacteriological results³ of the last 7 days for which analyses have been completed⁴;
- 4.3.1.2.2. The number of total coliform bacteria shall not exceed an MPN of 23 per 100 mL, in more than one sample in any 30-day period; and
- 4.3.1.2.3. No sample shall exceed an MPN of 240 per 100 mL.

4.3.2. **Water Recycling Requirements**

- 4.3.2.1. This Order authorizes the Permittee to reuse treated municipal wastewater that complies with effluent limitations contained in section 4.3.1 of the Order for uses that have been addressed in an approved title 22 Engineering Report and for which recycled water use agreements have been negotiated.
- 4.3.2.2. Recycled water production, distribution, and use shall be in compliance with all of the following requirements:
 - 4.3.2.2.1. All requirements of this Order, including Attachment G to this Order;
 - 4.3.2.2.2. Regulations related to recycled water contained in Water Code sections 13500 – 13577 (Water Reclamation);
 - 4.3.2.2.3. Regulations related to recycled water (including its subsequent revisions) contained in California Code of Regulations, title 17, sections 7583 – 7586, sections 7601 – 7605, and California Code of Regulations, title 22, division 4, chapter 3 (Uniform Statewide Recycling Criteria);
 - 4.3.2.2.4. A Division of Drinking Water (DDW)-approved title 22 Engineering Report that demonstrates or defines compliance with the Uniform Statewide Recycling Criteria (and any future amendments thereto);
 - 4.3.2.2.5. Any applicable Salt and Nutrient Management Plan adopted by the Regional Water Board as a Basin Plan amendment;

³ All operating channels shall be sampled. The daily result is the highest channel result when multiple channels are operating.

⁴ See Compliance Determination section 7.8 of this Order regarding compliance with bacteriological effluent limitations.

- 4.3.2.2.6. Any applicable water quality related California Environmental Quality Act (CEQA) mitigation measure;
- 4.3.2.2.7. Water Code section 1211 for facilities where the changes to the discharge are necessary to accomplish water recycling and will result in changes in flow in a watercourse; and
- 4.3.2.2.8. Policy for Water Quality Control for Recycled Water (Recycled Water Policy).

4.4. Other Requirements

4.4.1. Filtration Process Requirements

All recycled water produced at the Facility must be filtered using the Aqua DISK filter technology (Cloth Media Disk Filter) manufactured by Aqua-Aerobic Systems, Inc. as described in the Title 22 Engineering Report. The Permittee shall not make any changes, additions, or modifications to the Facility unless approval is obtained from DDW and the Regional Water Board. The Aqua DISK filter technology, Cloth Media Disk Filter is an alternative treatment technology and has been approved by DDW subject to the performance and operation conditions in the following sections 4.4.1.1 through 4.4.1.4.

- 4.4.1.1. **Filtration Rate.** The rate of filtration through the tertiary filters, as measured at Monitoring Location INT-001A, shall not exceed 6 gallons per minute per square foot of surface area or other filtration rates authorized in writing by the Regional Water Board Executive Officer and under conditions recommended by DDW.
- 4.4.1.2. **Secondary Effluent/Filter Influent Turbidity.** The secondary effluent/filter influent turbidity shall not exceed any of the following specifications at Monitoring Location INT-001A prior to the tertiary wastewater treatment process filters:
 - 4.4.1.2.1. 5 NTU for more than 15 minutes; and
 - 4.4.1.2.2. 10 NTU at any time.
- 4.4.1.3. **Effluent Turbidity.** The effluent from the tertiary wastewater treatment process filters shall at all times be filtered such that the filtered effluent does not exceed any of the following specifications at Monitoring Location INT-001B prior to discharge to the disinfection unit:
 - 4.4.1.3.1. An average of 2 NTU during any 24-hour period;
 - 4.4.1.3.2. 5 NTU more than 5 percent of the time during any 24-hour period; and

4.4.1.3.3. 10 NTU at any time.

4.4.1.4. Filtered effluent in excess of the turbidity specifications shall not enter the recycled water distribution system. Pursuant to title 22 sections 60304 and 60307, the Permittee shall have the capability and shall manage filtered effluent in excess of the turbidity specifications to automatically activate chemical addition or divert the wastewater to an upstream treatment process unit or to emergency storage. The Permittee shall provide notification of non-compliance with the filtration process requirements as required in section 9.1.2.3.2 of the MRP (Attachment E).

4.4.2. **Disinfection Process Requirements**

The Permittee shall operate the ultraviolet (UV) disinfection system described in the January 2021 Title 22 Engineering Report in accordance with the operating protocol and technical and administrative requirements set out by DDW in order to ensure compliance with total coliform bacteria effluent limitations specified in section 4.1.1.3 and 4.3.1.2 of this Order and disinfection water recycling specifications in section 4.3.1.2 of this Order. No changes, additions, or modifications can be made to the disinfection process unless approval is obtained from DDW and the Regional Water Board. The UV disinfection system has been approved by DDW subject to the performance and operation conditions in the following sections 4.4.2.1 through 4.4.2.15. Specifically, the Permittee shall:

- 4.4.2.1. Disinfect tertiary treated wastewater using a disinfection process that, when combined with the filtration process, has been demonstrated to inactivate and/or remove 99.999 percent of the plaque forming units of F-specific bacteriophage MS2, or polio virus in the wastewater. A virus that is at least as resistant to disinfection as polio virus may be used for purposes of the demonstration. The demonstration was performed on-site at the Russian River CSD Treatment Plant at both maximum and minimum plant flows. At a minimum, the Permittee demonstrated a 99.99 percent removal and/or inactivation of MS2 through the UV disinfection system only.
- 4.4.2.2. Provide continuous, reliable monitoring of flow, UV transmittance, UV intensity, UV dose, and UV power at Monitoring Location INT-002, and turbidity at Monitoring Location INT-001B. The Permittee must demonstrate compliance with the UV dose requirement.
- 4.4.2.3. Operate the UV disinfection system to provide a minimum UV dose of 100 millijoules per square centimeter (mJ/cm^2) at all times at Monitoring Location INT-002, unless otherwise approved by DDW.

- 4.4.2.4. Ensure that the UV transmittance (at least 254 nanometers) in the wastewater does not fall below 55 percent of maximum at any time, unless otherwise approved by DDW.
- 4.4.2.5. Visually inspect the quartz sleeves and cleaning system components per the manufacturer's operation manual for physical wear (scoring, solarization, seal leaks, etc.) and check the efficacy of the cleaning system.
- 4.4.2.6. Wipe/clean the quartz sleeves at least every 24 hours following the manufacturer's procedures to ensure the minimum required UV dose delivery is consistently achieved. Cleaning intervals shall be increased as necessary to ensure compliance with permit requirements such as UV dose and total coliform organism requirements.
- 4.4.2.7. Operate the UV disinfection system in accordance with an approved operations and maintenance plan, which specifies clearly the operational limits and responses required for critical alarms. The Permittee shall maintain a copy of the approved operations plan at the treatment plant and make the plan readily available to operations personnel and regulatory agencies. The Permittee shall post a quick reference plant operations data sheet at the treatment plant. The data sheet shall include the following information:
 - 4.4.2.7.1. The alarm set points for secondary and tertiary turbidity, high and low flow, UV dose and transmittance, UV lamp operation hours, and power.
 - 4.4.2.7.2. The values of secondary and tertiary turbidity, high and low flow, UV dose and transmittance, UV lamp operation hours, and power when flow must be diverted to waste.
 - 4.4.2.7.3. The values of high daily and weekly median total coliform when an operational response must be taken.
 - 4.4.2.7.4. The required frequency of calibration for all meters measuring turbidity, flow, UV transmittance, and power.
 - 4.4.2.7.5. The required frequency of mechanical cleaning/wiping and equipment inspection.
 - 4.4.2.7.6. The UV lamp age tracking procedures and replacement intervals.
- 4.4.2.8. Replace lamps every 9,400 hours of operation, or sooner, if there are indications that the lamps are failing to provide adequate disinfection. The Permittee shall maintain lamp age and lamp replacement records for a time period consistent with the record retention requirements in the Standard Provisions (Attachment D, Section 4).

- 4.4.2.9. Properly calibrate flow meters and UV transmittance (UVT) monitors to ensure proper disinfection.
- 4.4.2.10. Verify proper operation of flow meters weekly by measuring flow through the UV reactor for accuracy.
- 4.4.2.11. Inspect the UVT meter and check against a reference bench-top unit weekly to document accuracy.
- 4.4.2.12. Recalibrate the on-line UVT analyzer by a procedure recommended by the manufacturer if the on-line analyzer UVT reading (expressed in percent transmittance) varies from the bench-top spectrophotometer UVT reading (expressed in percent transmittance) by 2 percent or more.
- 4.4.2.13. Operate the UV disinfection system with a built-in automatic reliability feature that must be triggered when the system is below the target UV dose. If the measured UV dose drops below the minimum UV dose, the UV reactor in question must alarm and startup the next available row of UV lamps or UV lamp bank. Conditions that should divert flow include inability to meet the UV dose of 100 mJ/cm² at full power and both banks on.
- 4.4.2.14. Not allow equivalent or substitutions of equipment to occur without an adequate demonstration of equivalent disinfection performance to the satisfaction and approval of DDW.
- 4.4.2.15. Ensure that flow through the UV disinfection system not exceed 3.7 mgd, unless otherwise approved by DDW.
- 4.4.3. **Storage Ponds.** Ponds used for the storage of recycled water shall be constructed in a manner that protects groundwater. The Permittee shall submit design proposals for new storage ponds to the Regional Water Board for review prior to construction and demonstrate that the pond design incorporates features to protect groundwater from exceeding groundwater quality objectives.

5. RECEIVING WATER LIMITATIONS

Receiving water limitations are based on water quality objectives contained in the Basin Plan and are a required part of this Order. Receiving water conditions not in conformance with the limitations are not necessarily a violation of this Order. Compliance with receiving water limitations shall be measured at monitoring locations described in the MRP (Attachment E). The Regional Water Board may require an investigation and/or may consider other available information to determine cause and culpability prior to asserting that a violation has occurred.

5.1. Surface Water Limitations

Discharges from the Facility shall not cause the following in the receiving water:

- 5.1.1. The discharge shall not cause the dissolved oxygen (DO) concentration of the receiving water to be depressed below 9.0 mg/L daily and 11.0 mg/L as a 7-day rolling average.

In those waterbodies for which the aquatic life-based DO requirements are unachievable due to natural conditions, site-specific background DO requirements can be applied as water quality objectives by calculating the daily minimum DO necessary to maintain 85% DO saturation during the dry season and 90% DO saturation during the wet season under site salinity, site atmospheric pressure, and natural receiving water temperature. In no event may controllable factors reduce the daily minimum DO below 6.0 mg/L.

- 5.1.2. The discharge shall not cause the pH of receiving waters to be depressed below 6.5 nor raised above 8.5. Within this range, the discharge shall not cause the pH of the receiving waters to be changed at any time more than 0.5 units from that which occurs naturally.
- 5.1.3. The discharge shall not cause the specific conductance (micromhos) concentration of the receiving waters to increase above 285 micromhos more than 50 percent of the time, or above 375 micromhos more than 10 percent of the time. Compliance will be determined by evaluating the 50th percentile and 90th percentile of the monthly means of receiving water data each calendar year.
- 5.1.4. The discharge shall not cause the total dissolved solids concentration of the receiving waters to increase above 170 mg/L more than 50 percent of the time, or above 200 mg/L more than 10 percent of the time. Compliance will be determined by evaluating the 50th percentile and 90th percentile of the monthly means of receiving water data each calendar year.
- 5.1.5. The discharge shall not cause the turbidity of receiving waters to be increased more than 20 percent above naturally occurring background levels.
- 5.1.6. The discharge shall not cause receiving waters to contain suspended material in concentrations that cause nuisance or adversely affect beneficial uses.
- 5.1.7. The discharge shall not cause receiving waters to contain floating materials, including solids, liquids, foams, and scum, in concentrations that cause nuisance or adversely affect beneficial uses.

- 5.1.8. The discharge shall not cause receiving waters to contain taste- or odor-producing substances in concentrations that impart undesirable tastes or odors to fish flesh or other edible products of aquatic origin, that cause nuisance, or that adversely affect beneficial uses.
- 5.1.9. The discharge shall not cause coloration of receiving waters that causes nuisance or adversely affects beneficial uses.
- 5.1.10. The discharge shall not cause bottom deposits in receiving waters to the extent that such deposits cause nuisance or adversely affect beneficial uses.
- 5.1.11. The discharge shall not cause receiving waters to contain concentrations of biostimulatory substances that promote objectionable aquatic growth to the extent that such growth causes nuisance or adversely affects beneficial uses.
- 5.1.12. The discharge shall not cause receiving waters to contain toxic substances in concentrations that are toxic to, or that produce detrimental physiological responses in humans, plants, animals, or aquatic life. Compliance with this objective will be determined by use of indicator organisms, analyses of species diversity, population density, growth anomalies, bioassays of appropriate duration, or other appropriate methods, as specified by the Regional Water Board.
- 5.1.13. The discharge shall not cause a measurable temperature change in the receiving water at any time.
- 5.1.14. The discharge shall not cause an individual pesticide or combination of pesticides to be present in concentrations that adversely affect beneficial uses. The discharge shall not cause bioaccumulation of pesticide concentrations in bottom sediments or aquatic life.
- 5.1.15. The discharge shall not cause receiving waters to contain concentrations of pesticides in excess of Maximum Contaminant Levels (MCLs) established for these pollutants in title 22, division 4, chapter 15, article 5.5 of the CCR.
- 5.1.16. The discharge shall not cause receiving waters to contain oils, greases, waxes, or other materials in concentrations that result in a visible film or coating on the surface of the water or on objects in the water, that cause nuisance, or that otherwise affect beneficial uses.
- 5.1.17. The discharge shall not cause a violation of any applicable water quality standard for receiving waters adopted by the Regional Water Board or the State Water Board, as required by the federal Clean Water Act and regulations adopted thereunder. If more stringent applicable water quality standards are promulgated or approved pursuant to section 303 of the Clean Water Act, or

amendments thereto, the Regional Water Board will revise and modify this Order in accordance with such more stringent standards.

- 5.1.18. The discharge shall not cause concentrations of chemical constituents to occur in excess of MCLs and secondary MCLs (SMCLs) established for these pollutants in title 22, division 4, chapter 15, article 4, section 64431, article 5.5, section 64444, and article 16, section 64449 of the CCR.
- 5.1.19. The discharge shall not cause receiving waters to contain radionuclides in concentrations which are deleterious to human, plant, animal or aquatic life, nor which result in the accumulation of radionuclides in the food web to an extent which presents a hazard to human, plant, animal or indigenous aquatic life, nor in excess of the MCLs and SMCLs established for these pollutants in title 22, division 4, chapter 15, article 5, sections 64442 and 64443 of the CCR.
- 5.1.20. The bacteria water quality objective for all waters where the salinity is equal to or less than 1 part per thousand (ppth) 95 percent or more of the time during the calendar year is: a six week rolling geometric mean of *Escherichia coli* bacteria (*E. coli*) not to exceed 100 colony forming units (CFU) per 100 milliliter (mL), calculated weekly, and a statistical threshold value (STV) of 320 CFU/100 mL not to be exceeded by more than 10 percent of the samples collected in a calendar month, calculated in a static manner.

5.2. Groundwater Limitations

- 5.2.1. The collection, treatment, storage, and disposal of wastewater or use of recycled water shall not cause degradation of groundwater quality unless a technical evaluation is performed that demonstrates that any degradation that could reasonably be expected to occur, after implementation of reasonable BMPs, will not violate groundwater quality objectives or cause impacts to beneficial uses of groundwater.
- 5.2.2. The collection, treatment, storage, and disposal of wastewater or use of recycled water shall not cause or contribute to levels of chemical constituents in groundwater that exceed the MCLs and SMCLs established for these pollutants in title 22, division 4, chapter 15, article 4, section 64431, article 5.5, section 64444, and article 16 section 64449 of the CCR.
- 5.2.3. The collection, treatment, storage, and disposal of wastewater or use of recycled water shall not cause or contribute to levels of radionuclides in groundwater in concentrations that cause nuisance or adversely affect beneficial uses, nor in excess of the MCLs and SMCLs established for these pollutants in the CCR, title 22, division 4, chapter 15, article 5, sections 64442 and 64443 of the CCR.

- 5.2.4. The collection, treatment, storage, and disposal of wastewater or use of recycled water shall not cause groundwater to contain taste- or odor-producing substances in concentrations that cause nuisance or adversely affect beneficial uses.
- 5.2.5. The collection, treatment, storage, and disposal of wastewater or use of recycled water shall not cause the median of the most probable number of coliform organisms over any 7-day period to exceed 1.1 MPN/100 mL or 1 colony/100 mL in groundwaters used for domestic or municipal supply (MUN).
- 5.2.6. The collection, treatment, storage and disposal of wastewater or use of recycled water shall not cause groundwater to contain toxic substances in concentrations that are toxic to, or that produce detrimental physiological responses in humans, or that adversely affects beneficial uses. This limitation applies regardless of whether the toxicity is caused by a single substance or the synergistic effect of multiple substances.

6. PROVISIONS

6.1. Standard Provisions

- 6.1.1. **Federal Standard Provisions.** The Permittee shall comply with all Standard Provisions included in Attachment D of this Order.
- 6.1.2. **Regional Water Board Standard Provisions.** The Permittee shall comply with the following Regional Board standard provisions. In the event there is any conflict, duplication, or overlap between provisions specified by this Order, the more stringent provision shall apply:
- 6.1.2.1. Failure to comply with provisions or requirements of this Order, or violation of other applicable laws or regulations governing discharges from this facility, may subject the Permittee to administrative or civil liabilities, criminal penalties, and/or other enforcement remedies to ensure compliance. Additionally, certain violations may subject the Permittee to civil or criminal enforcement from appropriate local, state, or federal law enforcement entities.
- 6.1.2.2. In the event the Permittee does not comply or will be unable to comply for any reason, with any prohibition, final effluent limitation, recycled water specification, land discharge specification, receiving water limitation, or provision of this Order, that may result in significant threat to human health or the environment, such as inundation of treatment infrastructure, breach of pond containment, sanitary sewer overflow, recycled water main break or equivalent release, irrigation runoff, etc., that results in a discharge to a drainage channel or a surface water, the Permittee shall notify the Regional Water Board within 24 hours of having knowledge of such noncompliance.

Spill notification and reporting shall be conducted in accordance with section 5.5 of Attachment D and section 10.5 of the MRP (Attachment E).

6.2. Monitoring and Reporting Program (MRP) Requirements

The Permittee shall comply with the MRP, included as Attachment E to this Order, and future revisions thereto.

6.3. Special Provisions

6.3.1. Reopener Provisions

6.3.1.1. **Standard Revisions.** If applicable water quality standards are promulgated or approved pursuant to section 303 of the CWA, or amendments thereto, the Regional Water Board may reopen this Order and make modifications in accordance with such revised standards.

6.3.1.2. **Reasonable Potential.** This Order may be reopened for modification to include an effluent limitation if monitoring establishes that the discharge causes or has the reasonable potential to cause or contribute to, an excursion above a water quality criterion or objective applicable to the receiving water.

6.3.1.3. **Whole Effluent Toxicity.** As a result of a Toxicity Reduction Evaluation (TRE), this Order may be reopened to include a narrative or numeric chronic toxicity limitation, a new acute toxicity limitation, and/or a limitation for a specific toxicant identified in the TRE. Additionally, if a numeric acute or chronic toxicity water quality objective is adopted by the State Water Board, this Order may be reopened to include a numeric chronic toxicity effluent limitation based on that objective. This Order may also be reopened to establish an alternative representative instream waste concentration for evaluating compliance with acute and chronic toxicity limits.

6.3.1.4. **303(d)-Listed Pollutants.** If an applicable total maximum daily load (TMDL) (see Fact Sheet, section 3.4) program is adopted, this Order may be reopened and effluent limitations for the pollutant(s) that are the subject of the TMDL may be modified or imposed to conform this Order to the TMDL requirements.

6.3.1.5. **Water Effects Ratios (WERs) and Metal Translators.** A default WER of 1.0 has been used in this Order for calculating CTR criteria for applicable priority pollutant inorganic constituents, except for copper for which a site-specific WER of 2.41 has been used as further described in section 4.3.3.3 of the Fact Sheet. In addition, default dissolved-to-total metal translators have been used to convert water quality objectives from dissolved to total recoverable. If the Permittee performs studies to determine site-specific WERs and/or site-specific dissolved-to-total metal translators and submits a report that

demonstrates that WER or translator studies were performed in accordance with U.S. EPA or other approved guidance, this Order may be reopened to modify the effluent limitations for the applicable constituents.

- 6.3.1.6. **Nutrients.** This Order contains effluent monitoring requirements for nutrients (ammonia, unionized ammonia, nitrate, nitrite, organic nitrogen, and phosphorus). If new water quality objectives for nutrients are established, if monitoring data indicate the need for new or revised effluent limitations for any of these parameters, or if new or revised methods for compliance with effluent limitations for any of these parameters are developed, this Order may be reopened and modified to include new or modified effluent limitations or other requirements, as necessary.
- 6.3.1.7. **Salt and Nutrient Management Plans (SNMPs).** The State Water Board adopted the Water Quality Control Policy for Recycled Water (Recycled Water Policy) in 2009 and amended it in 2013 and 2018. The Recycled Water Policy recognizes the fact that some groundwater basins in the state contain salts and nutrients that exceed or threaten to exceed water quality objectives in the applicable Basin Plans, and that not all Basin Plans include adequate implementation procedures for achieving or ensuring compliance with the water quality objectives for salt or nutrients. However, in the absence of an approved SNMP, the Regional Water Board may impose specific requirements to ensure the preservation and maintenance of high-quality groundwater.
- 6.3.1.8. **Title 22 Engineering Report.** This Order implements title 22 requirements to protect public health. If the Permittee's title 22 engineering report requires modifications to this Order to adequately implement title 22, this Order may be reopened and modified as necessary.
- 6.3.1.9. **Pathogens.** This Order includes effluent and receiving water monitoring requirements for *E. coli* bacteria in order to develop data needed to assess whether or not the Permittee's discharge is a source of pathogens as defined in the Regional Water Board's Russian River Watershed Pathogen TMDL Action Plan adopted in August 2019 and to determine if the Facility complies with the bacteria water quality objective. This Order may be reopened if monitoring data indicate the need for additional monitoring requirements or water quality-based effluent limitations for bacteria to implement the Russian River Watershed Pathogen TMDL.
- 6.3.1.10. **Pretreatment Program.** If at any time, source control activities indicate that a pretreatment program is necessary, pursuant to 40 C.F.R. section 403.8(3), the Regional Water Board may reopen this permit to require the Permittee to develop a pretreatment program.

6.3.2. **Special Studies, Technical Papers, and Additional Monitoring Requirements**

6.3.2.1. **Land Discharge/Recycled Water Operations and Management Plan.**

6.3.2.1.1. By **May 1, 2022** the Permittee shall prepare and submit for Executive Officer Approval a Land Discharge/Recycled Water Operations and Management Plan in order to remain current and applicable to the discharge and requirements of this Order. The Land Discharge/Recycled Water Operations and Management Plan shall include (1) an update of the Permittee's September 2014 Recycled Water BMP/Operations and Management Plan to achieve consistency with the Water Recycling requirements of this Order, including the BMPs identified in the Recycled Water Technical Report Requirement 4.5 of Attachment G and the Water Recycling Administrative Report Requirement 4.6 of Attachment G; (2) a Land Discharge Management plan describing the measures and practices that the Permittee implements and proposes to implement to ensure that the forest irrigation system is operated in compliance with the requirements of this Order, including the requirements specified in sections 4.2.2.2 through 4.2.2.11 of this Order⁵. The Permittee shall implement the approved Plan. Prior to and after approval of the Plan, the Permittee shall maintain records, including but not limited to inspection reports, photographs, and monitoring data to demonstrate compliance with all land discharge and water recycling requirements in this Order.

6.3.2.1.2. The Land Discharge/Recycled Water Operations and Management Plan shall be reviewed annually and revised as needed to address any issues of non-compliance with this Order (i.e. persistent or excessive ponding, surface water runoff, if groundwater monitoring demonstrates increases in pollutants in groundwater beneath the lower Burch property). Revised Plans shall identify modified or new irrigation management practices and an implementation plan to achieve compliance with this Order. All revisions of the Plan shall be submitted for Executive Officer review and approval and implemented upon approval.

6.3.2.2. **Pathogen Special Study.** The Permittee shall conduct a study to assess the Facility's ability to comply with the bacteria water quality objective in Section 5.1.20 of the Order and required actions outlined in Table 4 of the Russian

⁵ The Land Discharge/Recycled Water Operations and Management Plan should address land disposal and water recycling in separate sections, as necessary, so that the unique issues and management approaches of each are clearly addressed.

River Watershed Pathogen TMDL Action Plan (Pathogen TMDL, TMDL, or Action Plan) adopted by the Regional Water Board in August 2019. By **July 1, 2022**, the Permittee shall submit, for Regional Water Board Executive Officer approval, a work plan for conducting the study. A final report summarizing the results of the Pathogen Special Study describing the Permittee's ability to comply with the bacteria water quality objective and the Pathogen TMDL, and, if necessary, a plan and schedule for achieving compliance with the Pathogen TMDL shall be submitted to the Regional Water Board in conjunction with the ROWD by **August 1, 2025**. If monitoring demonstrates that the Permittee cannot comply with the bacteria water quality objective and the Pathogen TMDL, the plan of compliance shall identify any other studies necessary to demonstrate compliance with the bacteria water quality objective and the Pathogen TMDL (i.e., study to determine whether the discharge includes pathogens of human origin).

- 6.3.2.3. **Disaster Preparedness Assessment Report and Action Plan.** Natural disasters, extreme weather events, sea level rise, and shifting precipitation patterns, some of which are projected to intensify due to climate change, have significant implications for wastewater treatment and operations. Some natural disasters are expected to become more frequent and extreme according to the current science on climate change.

In order to ensure that Facility operations are not disrupted, compliance with conditions of this Order are achieved, and receiving waters are not adversely impacted by permitted and unpermitted discharges, the Permittee shall submit a Disaster Preparedness Assessment Report and Action Plan to the Regional Water Board by **September 1, 2023**, for Executive Officer for review and approval.

The Permittee shall: (1) conduct an assessment of the wastewater treatment facility, operations, collection, and discharge systems to determine areas of short- and long-term vulnerabilities related to natural disasters and extreme weather, including sea level rise and other conditions projected by climate change science, if applicable; the assessment shall consider, as applicable, impacts to plant operations due to changing influent and receiving water quality, rising sea level, storm surges, fires, floods, earthquakes, tsunamis, back-to-back severe storms, and other extreme conditions that pose a risk to plant operations and water quality; (2) identify control measures needed to protect, improve, and maintain wastewater infrastructure, waste discharge compliance, and receiving water quality in the event of a natural disaster or, if applicable, under conditions resulting from climate change; (3) develop a schedule to implement necessary control measures. Control measures shall include, but are not limited to, emergency procedures, contingency plans, alarm/notification systems, training, backup power and equipment, and the

need for planned mitigations to ameliorate potential risks associated with extreme weather events and changing conditions resulting from climate change; and (4) implement the necessary control measures per the approved schedule of implementation.

6.3.3. **Best Management Practices and Pollution Prevention**

6.3.3.1. **Pollutant Minimization Program**

6.3.3.1.1. The Permittee shall, as required by the Regional Water Board Executive Officer (hereafter Executive Officer), develop and conduct a PMP, as further described below, when there is evidence (e.g., sample results from analytical methods more sensitive than those methods required by this Order, presence of whole effluent toxicity, health advisories for fish consumption, results of benthic or aquatic organism tissue sampling) that a priority pollutant is present in the effluent above an effluent limitation and either:

6.3.3.1.1.1. The concentration of the pollutant is reported as “Detected, but Not Quantified” (DNQ) and the effluent limitation is less than the reporting limit (RL);

6.3.3.1.1.2. A sample result is reported as non-detect (ND) and the effluent limitation is less than the method detection limit (MDL), using definitions described in Attachment A and reporting protocols described in MRP section 10.2.5.

6.3.3.1.2. **The PMP shall include**, but not be limited to, the following actions and submittals acceptable to the Regional Water Board:

6.3.3.1.2.1. An annual review and semi-annual monitoring of potential sources of the reportable priority pollutant(s), which may include fish tissue monitoring and other bio-uptake sampling;

6.3.3.1.2.2. Quarterly monitoring for the reportable priority pollutant(s) in the influent to the wastewater treatment system;

6.3.3.1.2.3. Submittal of a control strategy designed to proceed toward the goal of maintaining concentrations of the reportable priority pollutant(s) in the effluent at or below the effluent limitation;

6.3.3.1.2.4. Implementation of appropriate cost-effective control measures for the reportable priority pollutant(s), consistent with the control strategy; and

6.3.3.1.2.5. An annual status report that shall be submitted as part of the Annual Facility Report due **March 1st** to the Regional Water Board and shall include:

- 6.3.3.1.2.5.1. All PMP monitoring results for the previous year;
- 6.3.3.1.2.5.2. A list of potential sources of the reportable pollutant(s);
- 6.3.3.1.2.5.3. A summary of all actions undertaken pursuant to the control strategy;
and
- 6.3.3.1.2.5.4. A description of actions to be taken in the following year. The
concentration of the pollutant is reported as DNQ and the effluent
limitation is less than the reported ML;

6.3.4. **Construction, Operation and Maintenance Specifications**

- 6.3.4.1. **Proper Operation and Maintenance.** This Order (Attachment D, Standard Provision 1.4) requires that the Permittee at all times properly operate and maintain all facilities and systems of treatment and control (and related appurtenances) that are installed or used by the Permittee to achieve compliance with this Order. Proper operation and maintenance includes adequate laboratory quality control and appropriate quality assurance procedures.
- 6.3.4.2. **Operation and Maintenance Manual.** The Permittee shall maintain an updated Operation and Maintenance (O&M) Manual for the operational components of the Facility. The Permittee shall update the O&M Manual, as necessary, to conform to changes in operation and maintenance of the Facility. The Permittee shall operate and maintain the Facility in accordance with the most recently updated O&M Manual. The O&M Manual shall be readily available to operating personnel onsite and for review by state or federal inspectors. The O&M Manual shall include the following:
 - 6.3.4.2.1. Description of the Facility's organizational structure showing the number of employees, duties and qualifications, and plant attendance schedules (daily, weekends and holidays, part-time, etc.). The description should include documentation that the personnel are knowledgeable and qualified to operate the Facility so as to achieve the required level of treatment at all times.
 - 6.3.4.2.2. Detailed description of safe and effective operation and maintenance of treatment processes, process control instrumentation and equipment.
 - 6.3.4.2.3. Description of laboratory and quality assurance procedures.
 - 6.3.4.2.4. Process and equipment inspection and maintenance schedules.

- 6.3.4.2.5. Description of safeguards to assure that, should there be reduction, loss, or failure of electric power, the Permittee will be able to comply with requirements of this Order.
- 6.3.4.2.6. Description of preventive (fail-safe) and contingency (response and cleanup) plans for controlling accidental discharges, and for minimizing the effect of such events. These plans shall identify the possible sources (such as loading and storage areas, power outage, waste treatment unit failure, process equipment failure, tank and piping failure) of accidental discharges, untreated or partially treated waste bypass, and polluted drainage.
- 6.3.4.3. **Operating Records.** The Permittee shall maintain operating records at the Facility or at the Permittee's central depository.
- 6.3.4.3.1. The records shall include: all analyses specified in the reclamation criteria; any documentation of operational problems, plant and equipment breakdowns, and diversions to emergency storage or disposal; and documentation of all corrective or preventive actions taken.
- 6.3.4.3.2. Process or equipment failures triggering an alarm shall be recorded and maintained as a separate record file. The recorded information shall include the time and cause of failure and corrective action(s) taken.
- 6.3.5. **Special Provisions for Publicly-Owned Treatment Works (POTWs)**
- 6.3.5.1. **Wastewater Collection Systems**
- 6.3.5.1.1. **Statewide General WDRs for Sanitary Sewer Systems.**
- The Permittee has coverage under, and is separately subject to the requirements of, State Water Board Order No. 2006-0003-DWQ, Statewide General WDRs for Sanitary Sewer Systems, as amended by Order No. WQ 2013-0058-EXEC, and any subsequent revisions. As such, the Permittee provides notification and reporting of SSOs in accordance with the requirements of Order Nos. 2006-0003-DWQ and WQ 2013-0058-EXEC and any revisions thereto for operation of its wastewater collection system.
- 6.3.5.2. **Source Control and Pretreatment Provisions**
- 6.3.5.2.1. The Permittee shall perform source control functions and provide a summary of source control activities conducted in the Annual Report (due March 1st to the Regional Water Board). Source control functions and requirements shall include the following:

- 6.3.5.2.1.1. Implement the necessary legal authorities to monitor and enforce source control standards, restrict discharges of toxic materials to the collection system and inspect facilities connected to the system.
- 6.3.5.2.1.2. If waste haulers are allowed to discharge to the Facility, establish a waste hauler permit system, to be reviewed by the Executive Officer, to regulate waste haulers discharging to the collection system or Facility.
- 6.3.5.2.1.3. Perform public outreach to educate industrial, commercial, and residential users about the importance of preventing discharges of industrial toxic wastes to the wastewater treatment plant, at least once per year.
- 6.3.5.2.1.4. Perform ongoing inspections and monitoring, as necessary, to ensure adequate source control.
- 6.3.5.2.2. In the event that the Permittee identifies industrial wastes subject to regulation under the NPDES Pretreatment Program being discharged to the wastewater treatment plant, or the Regional Water Board or its Executive Officer determines that circumstances warrant pretreatment requirements in order to prevent interference [40 C.F.R. §403.3(j)] with the wastewater treatment Facility or Pass Through [40 C.F.R. §403.3(n)], then:
 - 6.3.5.2.2.1. The Permittee shall notify the Regional Water Board within 30 days after there are discharges that trigger the pretreatment requirements;
 - 6.3.5.2.2.2. The Permittee shall submit a revised ROWD and the pretreatment program for the Regional Water Board's review and approval as soon as possible, but not more than one year after the Permittee's notification to the Regional Water Board of the need for pretreatment requirements being triggered;
 - 6.3.5.2.2.3. The Permittee shall enforce the federal categorical pretreatment standards on all categorical industrial users (CIUs);
 - 6.3.5.2.2.4. The Permittee shall notify each CIU of its discharge effluent limits. The limits must be as stringent as the pretreatment standards contained in the applicable federal category (40 C.F.R. part 400-699). The Permittee may develop more stringent, technology-based local limits if it can show cause; and
 - 6.3.5.2.2.5. The Permittee shall notify the Regional Water Board if any CIU violates its discharge effluent limits.

6.3.5.2.3. The Regional Water Board retains the right to take legal action against an industrial user and/or the Permittee where a user fails to meet the approved applicable federal, state, or local pretreatment standards.

6.3.5.2.4. The Regional Water Board may amend this Order, at any time, to require the Permittee to develop and implement an industrial pretreatment program pursuant to the requirements of 40 C.F.R. part 403 if the Regional Water Board finds that the Facility receives pollutants from an IU that is subject to pretreatment standards, or if other circumstances so warrant.

6.3.5.3. Sludge Disposal and Handling Requirements

6.3.5.3.1. Sludge, as used in this Order, means the solid, semisolid, and liquid residues removed during primary, secondary, or tertiary wastewater treatment processes. Solid waste refers to grit and screenings generated during preliminary treatment. Biosolids refers to sludge that has been treated, tested, and demonstrated to be capable of being beneficially and legally used pursuant to federal and state regulations as a soil amendment for agriculture, silviculture, horticulture, and land reclamation activities.

6.3.5.3.2. All collected sludges and other solid waste removed from liquid wastes shall be removed from screens, sumps, ponds, and tanks as needed to ensure optimal plant operation and disposed of in accordance with applicable federal and state regulations.

6.3.5.3.3. The use and disposal of biosolids shall comply with all of the land application and disposal requirements in 40 C.F.R. part 503, which are enforceable by the U.S. EPA, not the Regional Water Board. If during the life of this Order, the state accepts primacy for implementation of 40 C.F.R. part 503, the Regional Water Board may also initiate enforcement where appropriate.

6.3.5.3.4. Sludge or biosolids that are disposed of in a municipal solid waste landfill or used as daily landfill cover shall meet the applicable requirements of 40 C.F.R. part 258. In the annual self-monitoring report, the Permittee shall report the amount of sludge placed in a landfill and the landfill(s) which received the sludge or biosolids.

6.3.5.3.5. The Permittee shall take all reasonable steps to prevent and minimize any sludge use or disposal in violation of this Order that may adversely affect human health or the environment.

6.3.5.3.6. Solids and sludge treatment, storage, and disposal or reuse shall not create a nuisance, such as objectionable odors or flies, and shall not result in groundwater contamination.

- 6.3.5.3.7. Solids and sludge treatment and storage sites shall have facilities adequate to divert surface water runoff from adjacent areas, protect the boundaries of the site from erosion, and prevent drainage from the treatment and storage site. Adequate protection is defined as protection from a design storm with a 100-year recurrence interval and 24-hour duration.
- 6.3.5.3.8. The discharge of sewage sludge and solids shall not cause waste material to be in a position where it is, or can be, conveyed from the treatment and storage sites and deposited in the waters of the state.
- 6.3.5.3.9. The Permittee currently sends all dewatered sludge to Redwood Landfill in Novato, California. The Permittee shall notify the Regional Water Board prior to changing biosolids use or disposal practices.

6.3.5.4. **Biosolids Management**

For any discharge of biosolids from the Facility, the Permittee shall comply with the following requirements:

- 6.3.5.4.1. For the land application of biosolids as soil amendment within the North Coast Region, the Permittee shall obtain or maintain coverage under the State Water Board Water Quality Order No. 2004-0012-DWQ General Waste Discharge Requirements for the Discharge of Biosolids to Land or Use as a Soil Amendment in Agricultural, Silvicultural, Horticultural, and Land Reclamation Activities, or
- 6.3.5.4.2. Alternatively, the Permittee may dispose of biosolids at another appropriately permitted facility.
- 6.3.5.4.3. New sludge treatment and storage facilities must comply with the requirements of the Water Code and title 27 of the CCR for the protection of water quality.

6.3.5.5. **Operator Certification**

Supervisors and operators of municipal wastewater treatment facilities shall possess a certificate of appropriate grade in accordance with title 23, CCR, section 3680. The State Water Board may accept experience in lieu of qualification training. In lieu of a properly certified wastewater treatment facility operator, the State Water Board may approve use of a water treatment facility operator of appropriate grade certified by DDW where water recycling is involved.

6.3.5.6. **Adequate Capacity**

If the Facility will reach capacity within 4 years, the Permittee shall notify the Regional Water Board. A copy of such notification shall be sent to appropriate local elected officials, local permitting agencies, and the press. Factors to be evaluated in assessing reserve capacity shall include, at a minimum, (1) comparison of the wet weather design flow with the highest daily flow, and (2) comparison of the average dry weather design flow with the lowest 30-day flow. The Permittee shall demonstrate that adequate steps are being taken to address the capacity problem. The Permittee shall submit a technical report to the Regional Water Board showing how flow volumes will be prevented from exceeding capacity, or how capacity will be increased, **within 120 days after providing notification to the Regional Water Board**, or within 120 days after receipt of Regional Water Board notification that the Facility will reach capacity within 4 years. The time for filing the required technical report may be extended by the Regional Water Board. An extension of 30 days may be granted by the Executive Officer, and longer extensions may be granted by the Regional Water Board itself. [CCR title 23, section 2232].

6.3.6. **Other Special Provisions**

6.3.6.1. **Storm Water**

For the control of storm water discharges from the Facility, if required, the Permittee shall seek separate authorization to discharge under the requirements of the State Water Board's Water Quality Order No. 2014-0057-DWQ, NPDES General Permit No. CAS000001, General Permit for Storm Water Discharges Associated with Industrial Activities (or subsequent renewed versions of the NPDES General Permit CAS000001), which is not incorporated by reference in this Order.

BMPs to control the run-on of storm water to the Facility site shall be maintained and upgraded as necessary. The Permittee shall describe the effectiveness of these storm water BMPs, as well as activities to maintain and upgrade these BMPs during the previous year, in its annual report to the Regional Water Board.

6.3.6.2. **Flood Control and Flow Reduction Mitigation**

The Permittee must routinely implement measures and actions in order to minimize the potential for sanitary sewer overflows and bypass events from the Facility. The Permittee's *Collection System Operations and Maintenance Plan* dated September 2002 identifies measures and actions that the Permittee committed to implementing over the last 20 years.

- 6.3.6.2.1. By **November 1, 2021**, the Permittee shall submit a report summarizing flood control and flow reduction mitigation measures implemented over the last five years, and include a discussion of whether or not these measures have been effective or not and a time schedule for updating this plan as part of its Sewer System Management Program required under the *Statewide General Waste Discharge Requirements for Sanitary Sewer Systems*, WQO No. 2006-0003.
- 6.3.6.2.2. By **February 1, 2023**, the Permittee shall submit for Executive Officer approval a work plan for preparing a revised System Evaluation and Capacity Assurance Plan (SECAP) in accordance with Provision 13(viii) of State Water Board Order No. 2006-0003-DWQ *Statewide General Waste Discharge Requirements for Sanitary Sewer Systems* (or subsequent renewed versions thereof). The work plan shall also address the additional specific requirements identified in sections 6.3.6.2.2.1 through 6.3.6.2.2.3, below.
- 6.3.6.2.2.1. The work plan shall describe the approach to completing the SECAP and identify the design storm or wet weather event that will be modeled for this analysis and include a time schedule for completing and submitting the revised SECAP by no later than **August 1, 2024**. The 2015 SECAP used a 24-hour 10-year return frequency storm for wet weather modelling. The SECAP shall be updated and modeled using a more appropriate storm frequency considering that the location of the collection system is in the flood plain and that the 2017 and 2019 storms demonstrate the need for this reassessment.
- 6.3.6.2.2.2. The work plan shall also include a task to conduct an engineering study that evaluates how the collection system and treatment plant are impacted by the Russian River and its tributaries during flood events. This evaluation shall consider low-lying portions of the collection system that become inundated during flood conditions, how these flood conditions impact the rest of the collection and treatment system and identify where SSOs and/or treatment system bypasses would occur. The evaluation shall document conditions, including flows and flood elevations at which SSOs occur, locations, duration, and scale where these impacts occur, and identify a mitigation and response plan. This engineering evaluation should consider a wide variety of design storms and flood conditions in order to understand how various scenarios impact the collection system and treatment plant. This information should be used to inform preventative measures, public notification, spill response, and site management that will be implemented under those conditions.
- 6.3.6.2.2.3. Upon completion of the engineering evaluation, the Permittees shall submit an Engineering Evaluation Final Report to the Regional Water

Board Executive Officer by **August 1, 2025** for review and approval. The Engineering Evaluation Final Report shall include all supporting engineering calculations, modeling, and maps used for this study, describe the results of the engineering evaluation and the Permittees' plan to correct all identified deficiencies, and provide a schedule of implementation for all corrective actions proposed. Corrective actions shall include both short-term contingency measures and long-term approaches that will be implemented to prevent, reduce, and mitigate sanitary sewer overflows and/or unauthorized releases. Corrective actions identified may consist of capital improvement projects that are necessary in order to eliminate, reduce, and mitigate overflow events.

6.3.6.2.3. By **August 1, 2025**, the Permittee shall submit a revised Collection System Operations and Management Plan (O&M Plan) that incorporates flow reduction mitigation measures and operational changes identified since the last O&M Plan submittal. Additionally, the O&M Plan shall identify how the Permittee will monitor and respond to conditions within the Russian River watershed that have been identified as having a strong relation to the occurrence of flooding in the Russian River within the District's service area.

6.3.7. **Compliance Schedules – Not Applicable**

This Order does not establish interim effluent limitations or schedules of compliance for final numeric effluent limitations.

7. **COMPLIANCE DETERMINATION**

Compliance with the discharge prohibitions and effluent limitations contained in sections 3 and 4 of this Order, respectively, will be determined as specified below.

7.1. **General**

Compliance with effluent limitations for priority pollutants, when effluent limitations have been established, shall be determined using sample reporting protocols defined in the MRP and Attachment A of this Order.

For purposes of reporting and administrative enforcement by the Regional and State Water Boards, the Permittee shall be deemed out of compliance with effluent limitations if the concentration of a pollutant in the monitoring sample is greater than the effluent limitation and greater than or equal to the reported minimum level (ML).

7.2. **Multiple Sample Data**

When determining compliance with an AMEL for priority pollutants, and more than one sample result is available, the Permittee shall compute the arithmetic mean unless the data set contains one or more reported determinations of “Detected, but Not Quantified” (DNQ) or “Not Detected” (ND). In those cases, the Permittee shall compute the median in place of the arithmetic mean in accordance with the following procedure.

- 7.2.1. The data set shall be ranked from low to high, ranking the reported ND determinations lowest, DNQ determinations next, followed by quantified values (if any). The order of the individual ND or DNQ determinations is unimportant.
- 7.2.2. The median value of the data set shall be determined. If the data set has an odd number of data points, then the median is the middle value. If the data set has an even number of data points, then the median is the average of the two middle values, unless one or both of the points are ND or DNQ, in which case the median value shall be the lower of the two data points where DNQ is lower than a value and ND is lower than DNQ and a value of zero shall be used for the ND or DNQ value in the median calculation for compliance purposes only. Using a value of zero for DNQ or ND samples does not apply when performing reasonable potential or antidegradation analyses.

7.3. **Average Monthly Effluent Limitation (AMEL)**

If the average (or when applicable, the median determined by subsection 7.2, above, for multiple sample data) of daily discharges over a calendar month exceeds the AMEL for a given parameter, this will represent a single violation, though the Permittee will be considered out of compliance for each day of that month for that parameter (e.g., resulting in 31 days of non-compliance in a 31-day month). If only a single sample is taken during the calendar month and the analytical result for that sample exceeds the AMEL, the Permittee will be considered out of compliance for that calendar month. The Permittee will only be considered out of compliance for days when the discharge occurs. If there are ND or DNQ results for a specific constituent in a calendar month, the Permittee shall calculate the median of all sample results within that month for compliance determination with the AMEL as described in section 7.2, above.

7.4. **Average Weekly Effluent Limitation (AWEL)**

If the average (or when applicable, the median determined by subsection 7.2, above, for multiple sample data) of daily discharges over a calendar week exceeds the AWEL for a given parameter, this will represent a single violation, though the Permittee will be considered out of compliance for each day of that week for that parameter, resulting in 7 days of non-compliance. If only a single sample is taken during the calendar week and the analytical result for that sample exceeds the AWEL, the Permittee will be considered out of compliance for that

calendar week. The Permittee will only be considered out of compliance for days when the discharge occurs. If there are ND or DNQ results for a specific constituent in a calendar week, the Permittee shall calculate the median of all sample results within that week for compliance determination with the AWEL as described in section 7.2, above.

7.5. Maximum Daily Effluent Limitation (MDEL)

If a daily discharge (or when applicable, the median determined by subsection 7.2, above, for multiple sample data of a daily discharge) exceeds the MDEL for a given parameter, the Permittee will be considered out of compliance for that parameter for that 1 day only within the reporting period.

7.6. Instantaneous Minimum Effluent Limitation

If the analytical result of a single grab sample is lower than the instantaneous minimum effluent limitation for a parameter, the Permittee will be considered out of compliance for that parameter for that single sample. Non-compliance for each sample will be considered separately (e.g., the results of two grab samples taken within a calendar day that both are lower than the instantaneous minimum effluent limitation would result in two instances of non-compliance with the instantaneous minimum effluent limitation).

If the Permittee monitors pH continuously, pursuant to 40 C.F.R. section 401.17, the Permittee shall be in compliance with the pH limitation specified herein provided that both of the following conditions are satisfied: (1) the total sum of time during which the pH values are outside the required range of pH values shall not exceed 7 hours and 26 minutes in any calendar month; and (2) no individual excursion from the range of pH values shall exceed 60 minutes.

7.7. Instantaneous Maximum Effluent Limitation

If the analytical result of a single grab sample is higher than the instantaneous maximum effluent limitation for a parameter, the Permittee will be considered out of compliance for that parameter for that single sample. Non-compliance for each sample will be considered separately (e.g., the results of two grab samples taken within a calendar day that both exceed the instantaneous maximum effluent limitation would result in two instances of non-compliance with the instantaneous maximum effluent limitation).

If the Permittee monitors pH continuously, pursuant to 40 C.F.R. section 401.17, the Permittee shall be in compliance with the pH limitation specified herein provided that both of the following conditions are satisfied: (1) the total sum of time during which the pH values are outside the required range of pH values shall not exceed 7 hours and 26 minutes in any calendar month; and (2) no individual excursion from the range of pH values shall exceed 60 minutes.

7.8. Bacteriological Limitations (Escherichia Coliform Bacteria and Total Coliform Bacteria)

7.8.1. Median (Total Coliform Bacteria).

- 7.8.1.1. The median is the central tendency concentration of the pollutant. The data set shall be ranked from low to high, ranking any ND concentrations lowest, followed by quantified values. The median value is determined based on the number of data points in the set. If the data set has an odd number of data points, then the median is the middle value. If the data set has an even number of data points, the median is the average of the two middle values,

unless one or both points are ND or DNQ, in which case the median value shall be the lower of the two middle data points. DNQ is lower than a detected value, and ND is lower than DNQ.

- 7.8.1.2. Compliance with 7-day median shall be determined as a rolling median during periods when sampling occurs more frequently than weekly. During periods when sampling is weekly, this requirement shall apply to each weekly sample.
- 7.8.2. All operating UV channels shall be sampled. The daily result is the highest result when multiple UV channels are operational. The daily result shall be used to determine compliance with the median, daily maximum, and no sample to exceed limitations in Effluent Limitations 4.1.1.3 of this Order.
- 7.8.3. **Six-week Rolling Geometric Mean (*E. coli* bacteria).** The rolling geometric mean shall be calculated using at least 5 sample results over a 6-week period from a site using the following formula:

The geometric mean is defined as **the *n*th root of the product of *n* numbers**

$$\text{Geometric Mean} = \sqrt[n]{(x_1)(x_2)(x_3) \dots (x_n)}$$

Where *x* is the sample value and *n* is the number of samples taken.⁶

- 7.8.4. **Statistical Threshold Value (*E. coli* bacteria).** (1) The data set shall be ranked from low to high, ranking any ND concentrations lowest, followed by quantified values. (2) The number of sample results should then be multiplied by 90 percent then rounded up to the nearest whole number. (3) Count the values in the data set starting from lowest to highest until the number indicated in step (2) is reached. (4) To be compliant with the statistical threshold value in Receiving Water Limitation 5.1.20, all sample results less than the point described in step 3 must be less than 100 MPN/100 mL.

7.9. Acute Toxicity Limitations

Compliance with the three-sample median acute toxicity effluent limitation shall be determined when there is a discharge, by calculating the median percent survival

⁶ If the Permittee samples less than five times during a six-week period, compliance shall be assessed using the statistical threshold value (STV) as described in section 7.8.4.

of the three most recent consecutive samples meeting all test acceptability criteria collected from Monitoring Location EFF 002.

Compliance with the accelerated monitoring and TRE provisions shall constitute compliance with the acute toxicity requirements, as specified in the MRP (Attachment E, sections 5.1 and 5.3).

7.10. Chronic Toxicity Requirements

Compliance with the accelerated monitoring and TRE provisions shall constitute compliance with the chronic toxicity requirements, as specified in the MRP (Attachment E, sections 5.2 and 5.3).

7.11. Average Dry Weather Flow

Compliance with the average daily flow prohibition in sections 3.8 of this Order will be determined once each calendar year by evaluating all flow data collected in a calendar year. The flow through the Facility, measured daily and averaged monthly, must be 0.51 mgd or less for the month with the lowest average monthly flow. A higher average dry weather flow, up to 0.71 mgd, may be allowed upon demonstration, to the satisfaction of the Regional Water Board Executive Officer, of sufficient storage, recycled water, and land disposal capacity to handle the full average dry weather design capacity.

7.12. Peak Daily Wet Weather Flow

The peak daily wet weather flow is the maximum flow rate that occurs over a 24-hour period. Compliance with the peak daily wet weather flow prohibition in section 3.8 of this Order will be determined daily by measuring the daily average flow at Monitoring Location EFF-001. If the measured daily average flow exceeds 3.5 mgd, the discharge is not in compliance with Prohibition 3.8 of this Order. In addition, if effluent flows exceed the treatment capacity of the treatment plant and result in the discharge of partially treated wastewater (e.g., spills or blending), the Permittee must implement public spill notification requirements in section 10.5.2 of the MRP and demonstrate that Flood Control and Flow Reduction Mitigation requirements of Order section 6.3.6.2 are being met.

ATTACHMENT A - DEFINITIONS

Arithmetic Mean (μ)

Also called the average, is the sum of measured values divided by the number of samples. For ambient water concentrations, the arithmetic mean is calculated as follows:

$$\text{Arithmetic mean} = \mu = \Sigma x / n$$

where: Σx is the sum of the measured ambient water concentrations, and n is the number of samples.

Average Monthly Effluent Limitation (AMEL)

The highest allowable average of daily discharges over a calendar month, calculated as the sum of all daily discharges measured during a calendar month divided by the number of daily discharges measured during that month.

Average Weekly Effluent Limitation (AWEL)

The highest allowable average of daily discharges over a calendar week (Sunday through Saturday), calculated as the sum of all daily discharges measured during a calendar week divided by the number of daily discharges measured during that week.

Basin Plan

A Basin Plan is a water quality control plan that is specific to a Regional Water Quality Control Board (Regional Water Board), and serves as regulations that: (1) define and designate beneficial uses of surface and ground waters, (2) establish water quality objectives to protect the beneficial uses, and (3) provide implementation measures.

Bioaccumulative Pollutants

Those substances taken up by an organism from its surrounding medium through gill membranes, epithelial tissue, or from food and subsequently concentrated and retained in the body of the organism.

California Integrated Water Quality System (CIWQS)

CIWQS is the State Water Board, statewide electronic reporting database that provides for electronic reporting of mandatory reports that are requirements of State and Regional Water Board-issued waste discharge requirements.

Coefficient of Variation (CV)

CV is a measure of the data variability and is calculated as the estimated standard deviation divided by the arithmetic mean of the observed values.

Daily Discharge

Daily Discharge is defined as either: (1) the total mass of the constituent discharged over the calendar day (12:00 am through 11:59 pm) or any 24-hour period that reasonably represents a calendar day for purposes of sampling (as specified in the permit), for a constituent with limitations expressed in units of mass or; (2) the unweighted arithmetic mean measurement of the constituent over the day for a constituent with limitations expressed in other units of measurement (e.g., concentration).

The daily discharge may be determined by the analytical results of a composite sample taken over the course of one day (a calendar day or other 24-hour period defined as a day) or by the arithmetic mean of analytical results from one or more grab samples taken over the course of the day.

For composite sampling, if 1 day is defined as a 24-hour period other than a calendar day, the analytical result for the 24-hour period will be considered as the result for the calendar day in which the 24-hour period ends.

Detected, but Not Quantified (DNQ)

DNQ are those sample results less than the RL, but greater than or equal to the laboratory's MDL. Sample results reported as DNQ are estimated concentrations.

Dilution Credit

Dilution Credit is the amount of dilution granted to a discharge in the calculation of a water quality-based effluent limitation, based on the allowance of a specified mixing zone. It is calculated from the dilution ratio or determined through conducting a mixing zone study or modeling of the discharge and receiving water.

Effective Concentration (EC)

A point estimate of the toxicant concentration that would cause an adverse effect on a quantal, "all or nothing," response (such as death, immobilization, or serious incapacitation) in a given percent of the test organisms. If the effect is death or immobility, the term lethal concentration (LC) may be used. EC values may be calculated using point estimation techniques such as probit, logit, and Spearman-Kärber. EC25 is the concentration of toxicant (in percent effluent) that causes a response in 25 percent of the test organisms.

Effluent Concentration Allowance (ECA)

ECA is a value derived from the water quality criterion/objective, dilution credit, and ambient background concentration that is used, in conjunction with the coefficient of variation for the effluent monitoring data, to calculate a long-term average (LTA) discharge concentration. The ECA has the same meaning as wasteload allocation (WLA) as used in U.S. EPA guidance (*Technical Support Document For Water Quality-based Toxics Control*, March 1991, second printing, EPA/505/2-90-001).

Enclosed Bays

Enclosed Bays means indentations along the coast that enclose an area of oceanic water within distinct headlands or harbor works. Enclosed bays include all bays where the narrowest distance between the headlands or outermost harbor works is less than 75 percent of the greatest dimension of the enclosed portion of the bay. Enclosed bays include, but are not limited to, Humboldt Bay, Bodega Harbor, Tomales Bay, Drake's Estero, San Francisco Bay, Morro Bay, Los Angeles-Long Beach Harbor, Upper and Lower Newport Bay, Mission Bay, and San Diego Bay. Enclosed bays do not include inland surface waters or ocean waters.

Estimated Chemical Concentration

The estimated chemical concentration that results from the confirmed detection of the substance by the analytical method below the ML value.

Estuaries

Estuaries means waters, including coastal lagoons, located at the mouths of streams that serve as areas of mixing for fresh and ocean waters. Coastal lagoons and mouths of streams that are temporarily separated from the ocean by sandbars shall be considered estuaries. Estuarine waters shall be considered to extend from a bay or the open ocean to a point upstream where there is no significant mixing of fresh water and seawater. Estuarine waters included, but are not limited to, the Sacramento-San Joaquin Delta, as defined in Water Code section 12220, Suisun Bay, Carquinez Strait downstream to the Carquinez Bridge, and appropriate areas of the Smith, Mad, Eel, Noyo, Russian, Klamath, San Diego, and Otay rivers. Estuaries do not include inland surface waters or ocean waters.

Geometric Mean

The geometric mean is a type of mean or average that indicates the central tendency or typical value of a set of numbers by using the product of their values (as opposed to the arithmetic mean which uses their sum). The geometric mean is defined as the nth root of the product of n numbers. The formula is expressed as:

$$\text{Geometric Mean} = \sqrt[n]{(x_1)(x_2)(x_3) \dots (x_n)}$$

Where:

x is the sample value and n is the number of samples taken.

Inhibition Concentration

The IC25 is typically calculated as a percentage of effluent. It is the level at which the organisms exhibit 25 percent reduction in biological measurement such as reproduction or growth. It is calculated statistically and used in chronic toxicity testing.

Inland Surface Waters

All surface waters of the state that do not include the ocean, enclosed bays, or estuaries.

Instantaneous Maximum Effluent Limitation

The highest allowable value for any single grab sample or aliquot (i.e., each grab sample or aliquot is independently compared to the instantaneous maximum limitation).

Instantaneous Minimum Effluent Limitation

The lowest allowable value for any single grab sample or aliquot (i.e., each grab sample or aliquot is independently compared to the instantaneous minimum limitation).

Lowest Observed Effect Concentration (LOEC)

The lowest concentration of an effluent or toxicant that results in adverse effects on the test organism (i.e., where the values for the observed endpoints are statistically different from the control).

Maximum Daily Effluent Limitation (MDEL)

The highest allowable daily discharge of a pollutant, over a calendar day (or 24-hour period). For pollutants with limitations expressed in units of mass, the daily discharge is calculated as the total mass of the pollutant discharged over the day. For pollutants with limitations expressed in other units of measurement, the daily discharge is calculated as the arithmetic mean measurement of the pollutant over the day.

Median

The middle measurement in a set of data. After the measurements are ranked in order, the median is the middle measurement if the number of measurements is odd. If the number of measurements is even, then the median is the arithmetic mean of the middle pair of ranked measurements.

Method Detection Limit (MDL)

MDL is the minimum concentration of a substance that can be reported with 99 percent confidence that the measured concentration is distinguishable from method blank results, as defined in 40 C.F.R. part 136, Attachment B.

Minimum Level (ML)

ML is the concentration at which the entire analytical system must give a recognizable signal and acceptable calibration point. The ML is the concentration in a sample that is equivalent to the concentration of the lowest calibration standard analyzed by a specific analytical procedure, assuming that all the method specified sample weights, volumes, and processing steps have been followed.

Mixing Zone

Mixing Zone is a limited volume of receiving water that is allocated for mixing with a wastewater discharge where water quality criteria can be exceeded without causing adverse effects to the overall water body.

Not Detected (ND)

Sample results which are less than the laboratory's MDL.

No Observed Effect Concentration (NOEC)

The highest tested concentration of an effluent or a test sample at which the effect is no different from the control effect, according to the statistical test used (see LOEC). The NOEC is usually the highest tested concentration of an effluent or toxicant that causes no observable effects on the aquatic test organisms (i.e., the highest concentration of toxicity at which the values for the observed responses do not statistically differ from the controls). It is determined using hypothesis testing.

Persistent Pollutants

Persistent pollutants are substances for which degradation or decomposition in the environment is nonexistent or very slow.

Pollutant Minimization Program (PMP)

PMP means waste minimization and pollution prevention actions that include, but are not limited to, product substitution, waste stream recycling, alternative waste management methods, and education of the public and businesses. The goal of the PMP shall be to reduce all potential sources of a priority pollutant(s) through pollutant minimization (control) strategies, including pollution prevention measures as appropriate, to maintain the effluent concentration at or below the water quality-based effluent limitation. Pollution prevention measures may be particularly appropriate for persistent bioaccumulative priority pollutants where there is evidence that beneficial uses are being impacted. The Regional Water Board may consider cost effectiveness when establishing the requirements of a PMP. The completion and implementation of a Pollution Prevention Plan, if required pursuant to Water Code section 13263.3(d), shall be considered to fulfill the PMP requirements.

Pollution Prevention

Pollution Prevention means any action that causes a net reduction in the use or generation of a hazardous substance or other pollutant that is discharged into water and includes, but is not limited to, input change, operational improvement, production process change, and product reformulation (as defined in Water Code section 13263.3). Pollution prevention does not include actions that merely shift a pollutant in wastewater from one environmental medium to another environmental medium, unless clear environmental benefits of such an approach are identified to the satisfaction of the State Water Resources Control Board (State Water Board) or Regional Water Board.

Publicly Owned Treatment Works (POTW)

A treatment works as defined in section 212 of the Clean Water Act (CWA), which is owned by a government agency as defined by section 502(4) of the CWA. Section 502(4) of the CWA defines a municipality as a city, town, borough, county, parish, district, association, or other public body created by or pursuant to state law and having jurisdiction over disposal of sewage, industrial wastes, or other wastes. This definition includes any devices and systems used in the storage, treatment, recycling, and recycling of municipal sewage or industrial wastes of a liquid nature. It also includes sewers, pipes and other conveyances only if they convey wastewater to a POTW Treatment Plant. The term also means the municipality as defined in section 502(4) of the CWA, which has jurisdiction over the Indirect Discharges to and the discharges from such a treatment works.

Receiving Water

A receiving water is a water of the State that receives a discharge of waste.

Recycled Water

Water which, as a result of treatment of municipal wastewater, is suitable for a direct beneficial use or a controlled use that would not otherwise occur and is therefore considered a valuable resource (Water Code section 13050). The terms “recycled water” and “reclaimed water” have the same meaning (Water Code section 26).

Reporting Level (RL)

The RL is the ML (and its associated analytical method) chosen by the Permittee for reporting and compliance determination from the MLs included in this Order, including an additional factor if applicable as discussed herein. The MLs included in this Order correspond to approved analytical methods for reporting a sample result that are selected by the Regional Water Board either from Appendix 4 of the SIP in accordance with section 2.4.2 of the SIP or established in accordance with section 2.4.3 of the SIP. The ML is based on the proper application of method-based analytical procedures for sample preparation and the absence of any matrix interferences. Other factors may be applied to the ML depending on the specific sample preparation steps employed. For example, the treatment typically applied in cases where there are matrix-effects is to dilute the sample or sample aliquot by a factor of ten. In such cases, this additional factor must be applied to the ML in the computation of the RL.

Septage

Defined as the liquid or solid material removed from a septic tank, cesspool, portable toilet, type III marine sanitation device, recreational vehicle’s sanitation tank, or similar storage or treatment works that receives domestic waste.

Sludge and Biosolids

Sludge, as used in this Order, means the solid, semisolid, and liquid residues removed during primary, secondary, or tertiary wastewater treatment processes. Solid waste refers to grit and screenings generated during preliminary treatment.

Biosolids refers to sludge that has been treated, tested, and demonstrated to be capable of being beneficially and legally used pursuant to federal and state regulations as a soil amendment for agriculture, silviculture, horticulture, and land reclamation activities.

Source of Drinking Water

Any water designated as municipal or domestic supply (MUN) in a Regional Water Board Basin Plan.

Standard Deviation (σ)

Standard Deviation is a measure of variability that is calculated as follows:

$$\sigma = (\sum[(x - \mu)^2]/(n - 1))^{0.5}$$

where: x is the observed value;

μ is the arithmetic mean of the observed values; and

n is the number of samples.

Statistical Threshold Value (STV)

The STV for the bacteria water quality objectives is a set value that approximates the 90th percentile of the water distribution of a bacterial population. For the bacteria Water Quality Objectives, the STV for *E. coli* is 320 CFU/100 mL.

Test of Significant Toxicity (TST)

The statistical approach described in *National Pollutant Discharge Elimination System Test of Significant Toxicity Implementation Document* (EPA 833-R10-003, 2010). TST was developed by the U.S. Environmental Protection Agency (EPA) for analyzing WET and ambient toxicity data. Using the TST approach, the sample is declared toxic if there is greater than or equal to a 25% effect in chronic tests, or if there is greater than or equal to a 20% effect in acute tests at the permitted instream waste concentration (IWC) (referred to as the toxic regulatory management decision (RMD)). The sample is declared non-toxic if there is less than or equal to a 10% effect at the IWC in acute or chronic tests (referred to as the non-toxic RMD).

Toxicity Reduction Evaluation (TRE)

TRE is a study conducted in a step-wise process designed to identify the causative agents of effluent or ambient toxicity, isolate the sources of toxicity, evaluate the effectiveness of toxicity control options, and then confirm the reduction in toxicity. The first steps of the TRE consist of the collection of data relevant to the toxicity, including additional toxicity testing, and an evaluation of facility operations and maintenance practices, and best management practices.

A Toxicity Identification Evaluation (TIE) may be required as part of the TRE, if appropriate. (A TIE is a set of procedures to identify the specific chemical(s) responsible for toxicity. These procedures are performed in three phases (characterization, identification, and confirmation) using aquatic organism toxicity tests.)

Water Quality Objective

A water quality objective is the amount of pollutant or a parameter level which is established for the reasonable protection of beneficial uses of surface waters and groundwater, and the prevention of nuisance.

ATTACHMENT B - MAPS

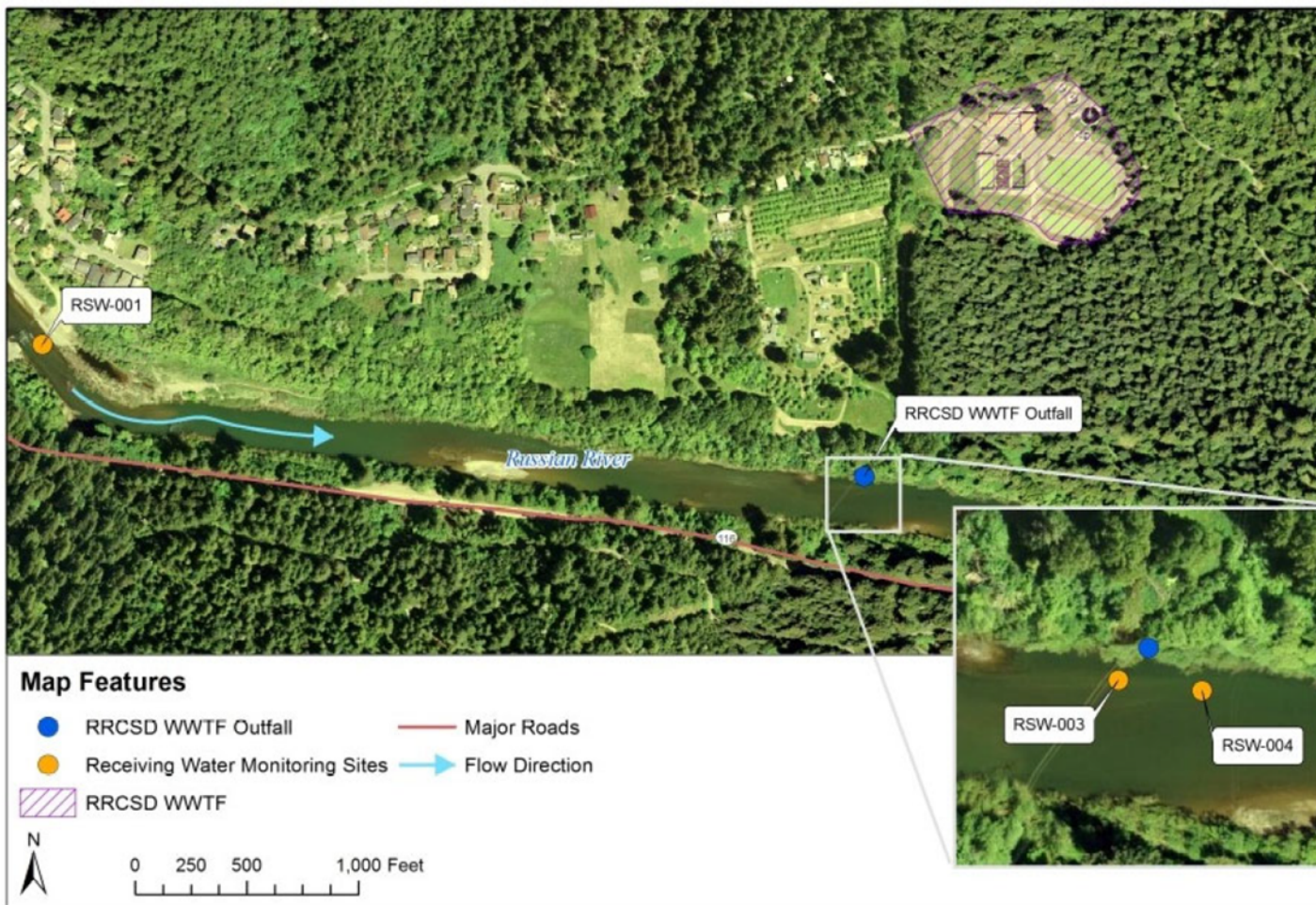

Figure B-1. Site Map

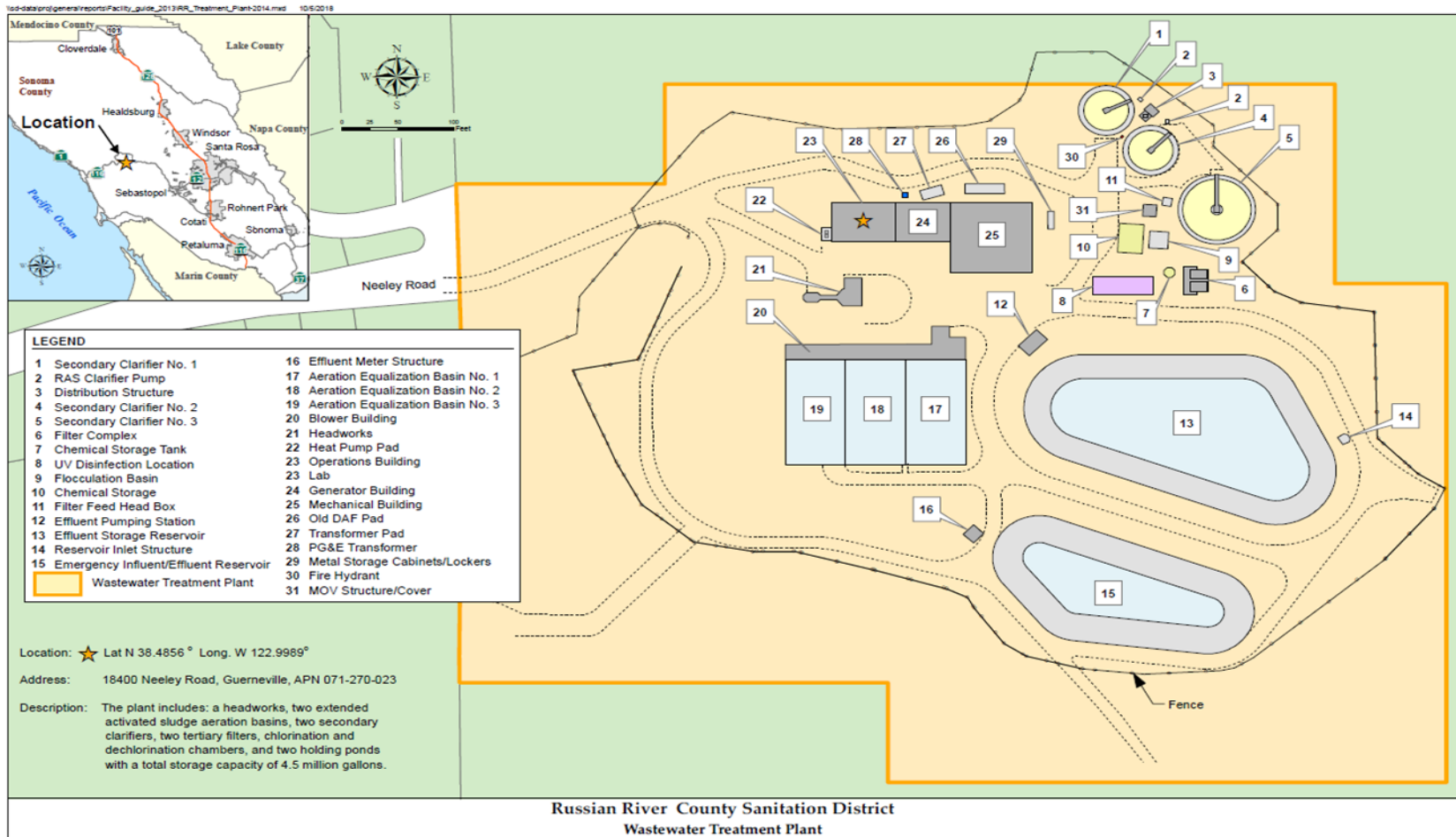

Figure B-2. Facility Layout Map

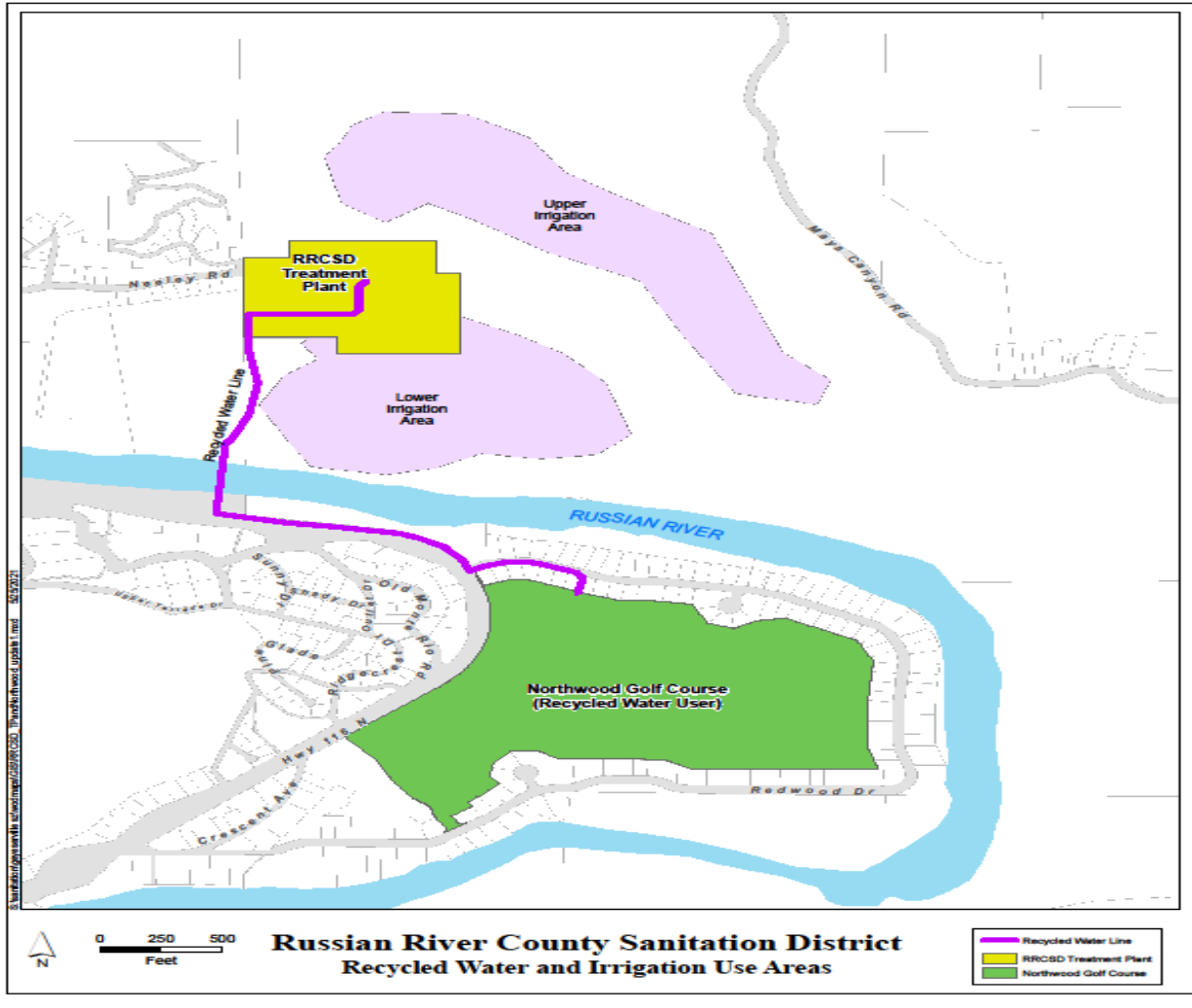
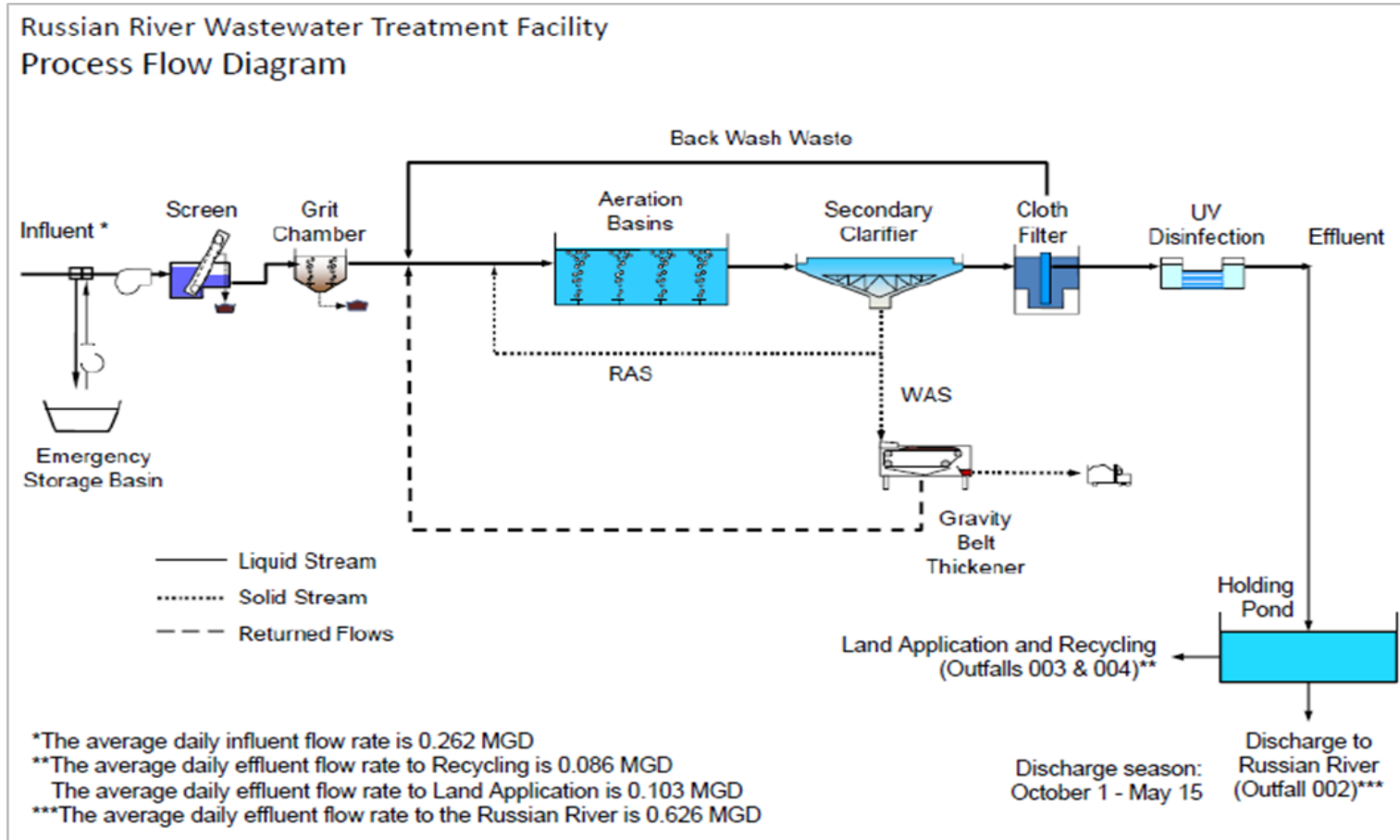

Figure B-3. Recycled Water and Irrigation (Land Disposal) Use Site Locations Map

ATTACHMENT C - FLOW SCHEMATIC



ATTACHMENT D - STANDARD PROVISIONS

1. STANDARD PROVISIONS – PERMIT COMPLIANCE

1.1. Duty to Comply

- 1.1.1. The Permittee must comply with all of the terms, requirements, and conditions of this Order. Any noncompliance constitutes a violation of the Clean Water Act (CWA) and the California Water Code and is grounds for enforcement action; permit termination, revocation and reissuance, or modification; denial of a permit renewal application; or a combination thereof. (40 C.F.R. § 122.41(a); Wat. Code, §§ 13261, 13263, 13265, 13268, 13000, 13001, 13304, 13350, 13385.)
- 1.1.2. The Permittee shall comply with effluent standards or prohibitions established under Section 307(a) of the CWA for toxic pollutants and with standards for sewage sludge use or disposal established under section 405(d) of the CWA within the time provided in the regulations that establish these standards or prohibitions, even if this Order has not yet been modified to incorporate the requirement. (40 C.F.R. § 122.41(a)(1))

1.2. Need to Halt or Reduce Activity Not a Defense

It shall not be a defense for a Permittee in an enforcement action that it would have been necessary to halt or reduce the permitted activity in order to maintain compliance with the conditions of this Order. (40 C.F.R. § 122.41(c).)

1.3. Duty to Mitigate

The Permittee shall take all reasonable steps to minimize or prevent any discharge in violation of this Order that has a reasonable likelihood of adversely affecting human health or the environment. (40 C.F.R. § 122.41(d).)

1.4. Proper Operation and Maintenance

The Permittee shall at all times properly operate and maintain all facilities and systems of treatment and control (and related appurtenances) which are installed or used by the Permittee to achieve compliance with the conditions of this Order. Proper operation and maintenance also includes adequate laboratory controls and appropriate quality assurance procedures. This provision requires the operation of backup or auxiliary facilities or similar systems that are installed by a Permittee only when necessary to achieve compliance with the conditions of this Order. (40 C.F.R. § 122.41(e).)

1.5. **Property Rights**

- 1.5.1. This Order does not convey any property rights of any sort or any exclusive privileges. (40 C.F.R. § 122.41(g).)
- 1.5.2. The issuance of this Order does not authorize any injury to persons or property or invasion of other private rights, or any infringement of state or local law or regulations. (40 C.F.R. § 122.5(c).)

1.6. **Inspection and Entry**

The Permittee shall allow the Regional Water Board, State Water Board, U.S. EPA, and/or their authorized representatives (including an authorized contractor acting as their representative), upon the presentation of credentials and other documents, as may be required by law, to (33 U.S.C. § 1318(a)(4)(B); 40 C.F.R. § 122.41(i); Wat. Code, §§ 13267, 13383):

- 1.6.1. Enter upon the Permittee's premises where a regulated facility or activity is located or conducted, or where records are kept under the conditions of this Order (33 U.S.C. § 1318(a)(4)(B)(i); 40 C.F.R. § 122.41(i)(1); Wat. Code, §§ 13267, 13383);
- 1.6.2. Have access to and copy, at reasonable times, any records that must be kept under the conditions of this Order (33 U.S.C. § 1318(a)(4)(B)(ii); 40 C.F.R. § 122.41(i)(2); Wat. Code, §§ 13267, 13383);
- 1.6.3. Inspect and photograph, at reasonable times, any facilities, equipment (including monitoring and control equipment), practices, or operations regulated or required under this Order (33 U.S.C. § 1318(a)(4)(B)(ii); 40 C.F.R. § 122.41(i)(3); Wat. Code, §§ 13267, 13383); and
- 1.6.4. Sample or monitor, at reasonable times, for the purposes of assuring Order compliance or as otherwise authorized by the CWA or the Water Code, any substances or parameters at any location. (33 U.S.C. § 1318(a)(4)(B); 40 C.F.R. § 122.41(i)(4); Wat. Code, §§ 13267, 13383.)

1.7. **Bypass**

1.7.1. **Definitions**

- 1.7.1.1. "Bypass" means the intentional diversion of waste streams from any portion of a treatment facility. (40 C.F.R. § 122.41(m)(1)(i).)
- 1.7.1.2. "Severe property damage" means substantial physical damage to property, damage to the treatment facilities, which causes them to become inoperable, or substantial and permanent loss of natural resources that can reasonably be

expected to occur in the absence of a bypass. Severe property damage does not mean economic loss caused by delays in production. (40 C.F.R. § 122.41(m)(1)(ii).)

- 1.7.2. **Bypass not exceeding limitations.** The Permittee may allow any bypass to occur which does not cause exceedances of effluent limitations, but only if it is for essential maintenance to assure efficient operation. These bypasses are not subject to the provisions listed in Standard Provisions – Permit Compliance 1.7.3, 1.7.4, and 1.7.5 below. (40 C.F.R. § 122.41(m)(2).)
- 1.7.3. **Prohibition of bypass.** Bypass is prohibited, and the Regional Water Board may take enforcement action against a Permittee for bypass, unless (40 C.F.R. § 122.41(m)(4)(i)):
 - 1.7.3.1. Bypass was unavoidable to prevent loss of life, personal injury, or severe property damage (40 C.F.R. § 122.41(m)(4)(i)(A));
 - 1.7.3.2. There were no feasible alternatives to the bypass, such as the use of auxiliary treatment facilities, retention of untreated wastes, or maintenance during normal periods of equipment downtime. This condition is not satisfied if adequate back up equipment should have been installed in the exercise of reasonable engineering judgment to prevent a bypass that occurred during normal periods of equipment downtime or preventive maintenance (40 C.F.R. § 122.41(m)(4)(i)(B)); and
 - 1.7.3.3. The Permittee submitted notice to the Regional Water Board as required under Standard Provisions – Permit Compliance 1.7.6 below. (40 C.F.R. § 122.41(m)(4)(i)(C))
- 1.7.4. **Burden of Proof.** In any enforcement proceeding, the permittee seeking to establish the bypass defense has the burden of proof.
- 1.7.5. The Regional Water Board may approve an anticipated bypass, after considering its adverse effects, if the Regional Water Board determines that it will meet the three conditions listed in Standard Provisions – Permit Compliance 1.7.3 above. (40 C.F.R. § 122.41(m)(4)(ii))
- 1.7.6. **Notice**
 - 1.7.6.1. **Anticipated bypass.** If the Permittee knows in advance of the need for a bypass, it shall submit prior notice, if possible at least 10 days before the date of the bypass. The notice shall be sent to the Regional Water Board. As of December 1, 2025, a notice shall also be submitted electronically to the initial recipient defined in Standard Provisions – Reporting 5.10 below. Notices shall

comply with 40 C.F.R. part 3, 40 C.F.R. section 122.22, and 40 C.F.R. part 127. (40 C.F.R. § 122.41(m)(3)(i))

- 1.7.6.2. **Unanticipated bypass.** The Permittee shall submit a notice of an unanticipated bypass as required in Standard Provisions - Reporting 5.5 below (24-hour notice). Notices shall comply with 40 C.F.R. part 3, 40 C.F.R. section 122.22, and 40 C.F.R. part 127. (40 C.F.R. § 122.41(m)(3)(ii).)

1.8. Upset

Upset means an exceptional incident in which there is unintentional and temporary noncompliance with technology-based permit effluent limitations because of factors beyond the reasonable control of the Permittee. An upset does not include noncompliance to the extent caused by operational error, improperly designed treatment facilities, inadequate treatment facilities, lack of preventive maintenance, or careless or improper operation. (40 C.F.R. § 122.41(n)(1).)

- 1.8.1. **Effect of an upset.** An upset constitutes an affirmative defense to an action brought for noncompliance with such technology-based permit effluent limitations if the requirements of Standard Provisions – Permit Compliance 1.8.2 below are met. No determination made during administrative review of claims that noncompliance was caused by upset, and before an action for noncompliance, is final administrative action subject to judicial review. (40 C.F.R. § 122.41(n)(2).)
- 1.8.2. **Conditions necessary for a demonstration of upset.** A Permittee who wishes to establish the affirmative defense of upset shall demonstrate, through properly signed, contemporaneous operating logs or other relevant evidence that (40 C.F.R. § 122.41(n)(3)):
- 1.8.2.1. An upset occurred and that the Permittee can identify the cause(s) of the upset (40 C.F.R. § 122.41(n)(3)(i));
- 1.8.2.2. The permitted facility was, at the time, being properly operated (40 C.F.R. § 122.41(n)(3)(ii));
- 1.8.2.3. The Permittee submitted notice of the upset as required in Standard Provisions – Reporting 5.5.2.2 below (24-hour notice) (40 C.F.R. § 122.41(n)(3)(iii)); and
- 1.8.2.4. The Permittee complied with any remedial measures required under Standard Provisions – Permit Compliance 1.3 above. (40 C.F.R. § 122.41(n)(3)(iv).)

- 1.8.3. **Burden of proof.** In any enforcement proceeding, the Permittee seeking to establish the occurrence of an upset has the burden of proof. (40 C.F.R. § 122.41(n)(4).)

2. STANDARD PROVISIONS – PERMIT ACTION

2.1. General

This Order may be modified, revoked and reissued, or terminated for cause. The filing of a request by the Permittee for modification, revocation and reissuance, or termination, or a notification of planned changes or anticipated noncompliance does not stay any Order condition. (40 C.F.R. § 122.41(f).)

2.2. Duty to Reapply

If the Permittee wishes to continue an activity regulated by this Order after the expiration date of this Order, the Permittee must apply for and obtain a new permit. (40 C.F.R. § 122.41(b).)

2.3. Transfers

This Order is not transferable to any person except after notice to the Regional Water Board. The Regional Water Board may require modification or revocation and reissuance of the Order to change the name of the Permittee and incorporate such other requirements as may be necessary under the CWA and the Water Code. (40 C.F.R. §§ 122.41(l)(3), 122.61)

3. STANDARD PROVISIONS – MONITORING

- 3.1. Samples and measurements taken for the purpose of monitoring shall be representative of the monitored activity. (40 C.F.R. § 122.41(j)(1).)
- 3.2. Monitoring must be conducted according to test procedures approved under 40 C.F.R. part 136 for the analyses of pollutants unless another method is required under 40 C.F.R. chapter 1, subchapters N or O. Monitoring must be conducted according to sufficiently sensitive test methods approved under 40 C.F.R. part 136 for the analysis of pollutants or pollutant parameters or as required under 40 C.F.R. chapter 1, subchapters N or O. For the purposes of this paragraph, a method is sufficiently sensitive when:
- 3.2.1. The method minimum level (ML) is at or below the level of the most stringent effluent limitation established in the permit for the measured pollutant or pollutant parameter, and either the method ML is at or below the level of the most stringent applicable water quality criterion for the measured pollutant or pollutant parameter or the method ML is above the applicable water quality criterion but the amount of the pollutant or pollutant parameter in the facility's

discharge is high enough that the method detects and quantifies the level of the pollutant or pollutant parameter in the discharge; or

- 3.2.2. The method has the lowest ML of the analytical methods approved under 40 C.F.R. part 136 or required under 40 C.F.R. chapter 1, subchapter N for the measured pollutant or pollutant parameter.

In the case of pollutants or pollutant parameters for which there are no approved methods under 40 C.F.R. part 136 or otherwise required under 40 C.F.R. chapter 1, subchapters N or O, monitoring must be conducted according to a test procedure specified in this Order for such pollutants or pollutant parameters. (40 C.F.R. §§ 122.21(e)(3), 122.41(j)(4), 122.44(i)(1)(iv))

In the case of sludge use or disposal approved under 40 C.F.R. part 136, monitoring must be conducted according to test procedures in part 503 unless otherwise specified in 40 C.F.R. or other test procedures have been specified in this Order.

4. STANDARD PROVISIONS – RECORDS

- 4.1. Except for records of monitoring information required by this Order related to the Permittee's sewage sludge use and disposal activities, which shall be retained for a period of at least five years (or longer as required by 40 C.F.R. part 503), the Permittee shall retain records of all monitoring information, including all calibration and maintenance records and all original strip chart recordings for continuous monitoring instrumentation, copies of all reports required by this Order, and records of all data used to complete the application for this Order, for a period of at least three (3) years from the date of the sample, measurement, report or application. This period may be extended by request of the Regional Water Board Executive Officer at any time. (40 C.F.R. § 122.41(j)(2))

4.2. Records of monitoring information shall include:

- 4.2.1. The date, exact place, and time of sampling or measurements (40 C.F.R. § 122.41(j)(3)(i));
- 4.2.2. The individual(s) who performed the sampling or measurements (40 C.F.R. § 122.41(j)(3)(ii));
- 4.2.3. The date(s) analyses were performed (40 C.F.R. § 122.41(j)(3)(iii));
- 4.2.4. The individual(s) who performed the analyses (40 C.F.R. § 122.41(j)(3)(iv));
- 4.2.5. The analytical techniques or methods used (40 C.F.R. § 122.41(j)(3)(v)); and
- 4.2.6. The results of such analyses. (40 C.F.R. § 122.41(j)(3)(vi).)

4.3. Claims of confidentiality for the following information will be denied (40 C.F.R. § 122.7(b)):

- 4.3.1. The name and address of any permit applicant or Permittee (40 C.F.R. § 122.7(b)(1)); and
- 4.3.2. Permit applications and attachments, permits and effluent data. (40 C.F.R. § 122.7(b)(2).)

5. STANDARD PROVISIONS – REPORTING

5.1. Duty to Provide Information

The Permittee shall furnish to the Regional Water Board, State Water Board, or U.S. EPA within a reasonable time, any information which the Regional Water Board, State Water Board, or U.S. EPA may request to determine whether cause exists for modifying, revoking and reissuing, or terminating this Order or to determine compliance with this Order. Upon request, the Permittee shall also furnish to the Regional Water Board, State Water Board, or U.S. EPA copies of records required to be kept by this Order. (40 C.F.R. § 122.41(h); Wat. Code, §§ 13267, 13383)

5.2. Signatory and Certification Requirements

- 5.2.1. All applications, reports, or information submitted to the Regional Water Board, State Water Board, and/or U.S. EPA shall be signed and certified in accordance with Standard Provisions – Reporting 5.2.2 through 5.2.6 below. (40 C.F.R. § 122.41(k))
- 5.2.2. All permit applications shall be signed by either a principal executive officer or ranking elected official. For purposes of this provision, a principal executive officer of a federal agency includes: (i) the chief executive officer of the agency, or (ii) a senior executive officer having responsibility for the overall operations of a principal geographic unit of the agency (e.g., Regional Administrators of U.S. EPA). (40 C.F.R. § 122.22(a)(3).)
- 5.2.3. All reports required by this Order and other information requested by the Regional Water Board, State Water Board, or U.S. EPA shall be signed by a person described in Standard Provisions – Reporting 5.2.2 above, or by a duly authorized representative of that person. A person is a duly authorized representative only if:
 - 5.2.3.1. The authorization is made in writing by a person described in Standard Provisions – Reporting 5.2.2 above (40 C.F.R. § 122.22(b)(1));

- 5.2.3.2. The authorization specifies either an individual or a position having responsibility for the overall operation of the regulated facility or activity such as the position of plant manager, operator of a well or a well field, superintendent, position of equivalent responsibility, or an individual or position having overall responsibility for environmental matters for the company. (A duly authorized representative may thus be either a named individual or any individual occupying a named position.) (40 C.F.R. § 122.22(b)(2)); and
- 5.2.3.3. The written authorization is submitted to the Regional Water Board and State Water Board. (40 C.F.R. § 122.22(b)(3))
- 5.2.4. If an authorization under Standard Provisions – Reporting 5.2.3 above is no longer accurate because a different individual or position has responsibility for the overall operation of the facility, a new authorization satisfying the requirements of Standard Provisions – Reporting 5.2.3 above must be submitted to the Regional Water Board and State Water Board prior to or together with any reports, information, or applications, to be signed by an authorized representative. (40 C.F.R. § 122.22(c))
- 5.2.5. Any person signing a document under Standard Provisions – Reporting 5.2.2 or 5.2.3 above shall make the following certification:
- “I certify under penalty of law that this document and all attachments were prepared under my direction or supervision in accordance with a system designed to assure that qualified personnel properly gather and evaluate the information submitted. Based on my inquiry of the person or persons who manage the system or those persons directly responsible for gathering the information, the information submitted is, to the best of my knowledge and belief, true, accurate, and complete. I am aware that there are significant penalties for submitting false information, including the possibility of fine and imprisonment for knowing violations.”* (40 C.F.R. § 122.22(d).)
- 5.2.6. Any person providing the electronic signature for documents described in Standard Provisions – 5.2.1, 5.2.2, or 5.2.3 that are submitted electronically shall meet all relevant requirements of Standard Provisions – Reporting 5.2, and shall ensure that all relevant requirements of 40 C.F.R. part 3 (Cross-Media Electronic Reporting) and 40 C.F.R. part 127 (NPDES Electronic Reporting Requirements) are met for that submission. (40 C.F.R § 122.22(e).)

5.3. **Monitoring Reports**

- 5.3.1. Monitoring results shall be reported at the intervals specified in the Monitoring and Reporting Program (Attachment E) in this Order. (40 C.F.R. § 122.41(l)(4).)

- 5.3.2. Monitoring results must be reported on a Discharge Monitoring Report (DMR) form or forms provided or specified by the Regional Water Board or State Water Board for reporting results of monitoring, sludge use, or disposal practices. As of December 21, 2025, all reports and forms must be submitted electronically to the initial recipient defined in Standard Provisions – Reporting 5.10 and comply with 40 C.F.R. part 3, 40 C.F.R. section 122.22, and 40 C.F.R. part 127. (40 C.F.R. § 122.41(l)(4)(i))
- 5.3.3. If the Permittee monitors any pollutant more frequently than required by this Order using test procedures approved under 40 C.F.R. part 136, or another method required for an industry-specific waste stream under 40 C.F.R. chapter 1, subchapters N or O, the results of such monitoring shall be included in the calculation and reporting of the data submitted in the DMR or sludge reporting form specified by the Regional Water Board or State Water Board. (40 C.F.R. § 122.41(l)(4)(ii))
- 5.3.4. Calculations for all limitations, which require averaging of measurements, shall utilize an arithmetic mean unless otherwise specified in this Order. (40 C.F.R. § 122.41(l)(4)(iii).)

5.4. **Compliance Schedules**

Reports of compliance or noncompliance with, or any progress reports on, interim and final requirements contained in any compliance schedule of this Order, shall be submitted no later than 14 days following each schedule date. (40 C.F.R. § 122.41(l)(5).)

5.5. **Twenty-Four Hour Reporting**

- 5.5.1. The Permittee shall report any noncompliance which may endanger health or the environment. Any information shall be provided orally within 24 hours from the time the Permittee becomes aware of the circumstances. A written submission shall also be provided within five (5) days of the time the Permittee becomes aware of the circumstances. The written submission shall contain a description of the noncompliance and its cause; the period of noncompliance, including exact dates and times, and if the noncompliance has not been corrected, the anticipated time it is expected to continue; and steps taken or planned to reduce, eliminate, and prevent reoccurrence of the noncompliance. (40 C.F.R. § 122.41(l)(6)(i))

For noncompliance events related to combined sewer overflows, sanitary sewer overflows, or bypass events, these reports must include the data described above (with the exception of time of discovery) as well as the type of event (i.e., combined sewer overflow, sanitary sewer overflow, or bypass event), type of overflow structure (e.g., manhole, combined sewer overflow outfall), discharge

volume untreated by the treatment works treating domestic sewage, types of human health and environmental impacts of the event, and whether the noncompliance was related to wet weather.

As of December 21, 2025, all reports related to combined sewer overflows, sanitary sewer overflows, or bypass events must be submitted electronically to the initial recipient defined in Standard Provisions – Reporting 5.10. The reports shall comply with 40 C.F.R. part 3, 40 C.F.R. section 122.22, and 40 C.F.R. part 127. The Regional Water Board may also require the Permittee to electronically submit reports not related to combined sewer overflows, sanitary sewer overflows, or bypass events under this section. (40 C.F.R. § 122.41(l)(6)(i))

- 5.5.2. The following shall be included as information that must be reported within 24 hours:
- 5.5.2.1. Any unanticipated bypass that exceeds any effluent limitation in this Order. (40 C.F.R. § 122.41(l)(6)(ii)(A).)
- 5.5.2.2. Any upset that exceeds any effluent limitation in this Order. (40 C.F.R. § 122.41(l)(6)(ii)(B).)
- 5.5.3. The Regional Water Board may waive the above required written report on a case-by-case basis if an oral report has been received within 24 hours. (40 C.F.R. § 122.41(l)(6)(ii)(B).)

5.6. **Planned Changes**

The Permittee shall give notice to the Regional Water Board as soon as possible of any planned physical alterations or additions to the permitted facility. Notice is required under this provision only when (40 C.F.R. § 122.41(l)(1)):

- 5.6.1. The alteration or addition to a permitted facility may meet one of the criteria for determining whether a facility is a new source in section 122.29(b) (40 C.F.R. § 122.41(l)(1)(i)); or
- 5.6.2. The alteration or addition could significantly change the nature or increase the quantity of pollutants discharged. This notification applies to pollutants that are not subject to effluent limitations in this Order. (40 C.F.R. § 122.41(l)(1)(ii).) or
- 5.6.3. The alteration or addition results in a significant change in the Permittee's sludge use or disposal practices, and such alteration, addition, or change may justify the application of permit conditions that are different from or absent in the existing permit, including notification of additional use or disposal sites not reported during the permit application process or not reported pursuant to an approved land application plan. (40 C.F.R. § 122.41(l)(1)(iii))

5.7. Anticipated Noncompliance

The Permittee shall give advance notice to the Regional Water Board of any planned changes in the permitted facility or activity that may result in noncompliance with this Order's requirements. (40 C.F.R. § 122.41(l)(2).)

5.8. Other Noncompliance

The Permittee shall report all instances of noncompliance not reported under Standard Provisions – Reporting 5.3, 5.4, and 5.5 above at the time monitoring reports are submitted. The reports shall contain the information listed in Standard Provision – Reporting 5.5 above. For noncompliance events related to combined sewer overflows, sanitary sewer overflows, or bypass events, these reports shall contain the information described in Standard Provision – Reporting 5.5 and the applicable required data in appendix A to 40 C.F.R. part 127. As of December 21, 2025, the Regional Water Board may also require the Permittee to electronically submit reports not related to combined sewer overflows, sanitary sewer overflows, or bypass events under this section. (40 C.F.R. § 122.41(l)(7))

5.9. Other Information

When the Permittee becomes aware that it failed to submit any relevant facts in a permit application, or submitted incorrect information in a permit application or in any report to the Regional Water Board, State Water Board, or U.S. EPA, the Permittee shall promptly submit such facts or information. (40 C.F.R. § 122.41(l)(8).)

5.10. Initial Recipient for Electronic Reporting Data

The owner, operator, or the duly authorized representative is required to electronically submit NPDES information specified in appendix A to 40 C.F.R. part 127 to the initial recipient defined in 40 C.F.R. section 127.2(b). U.S. EPA will identify and publish the list of initial recipients on its website and in the Federal Register, by state and by NPDES data group [see 40 C.F.R. section 127.2(c)]. U.S. EPA will update and maintain this listing. (40 C.F.R. § 122.41(l)(9))

6. STANDARD PROVISIONS – ENFORCEMENT

- 6.1. The Regional Water Board is authorized to enforce the terms of this permit under several provisions of the Water Code, including, but not limited to, sections 13268, 13350, 13385, 13386, and 13387.

7. ADDITIONAL PROVISIONS – NOTIFICATION LEVELS

7.1. Publicly-Owned Treatment Works (POTWs)

All POTWs shall provide adequate notice to the Regional Water Board of the following (40 C.F.R. § 122.42(b)):

- 7.1.1. Any new introduction of pollutants into the POTW from an indirect discharger that would be subject to sections 301 or 306 of the CWA if it were directly discharging those pollutants (40 C.F.R. § 122.42(b)(1)); and
- 7.1.2. Any substantial change in the volume or character of pollutants being introduced into that POTW by a source introducing pollutants into the POTW at the time of adoption of the Order. (40 C.F.R. § 122.42(b)(2).)
- 7.1.3. Adequate notice shall include information on the quality and quantity of effluent introduced into the POTW as well as any anticipated impact of the change on the quantity or quality of effluent to be discharged from the POTW. (40 C.F.R. § 122.42(b)(3)).

ATTACHMENT E - MONITORING AND REPORTING PROGRAM

TABLE OF CONTENTS

1.	General Monitoring Provisions	E-3
2.	Monitoring Locations	E-5
3.	Influent Monitoring Requirements	E-8
3.1.	Monitoring Location INF-001	E-8
4.	Effluent Monitoring Requirements	E-9
4.1.	Monitoring Location EFF-001 and EFF-005	E-9
4.2.	Monitoring Locations EFF-002 and EFF-005.....	E-10
5.	Whole Effluent Toxicity Testing Requirements.....	E-13
5.1.	Acute Toxicity Testing	E-13
5.2.	Chronic Toxicity Testing	E-17
5.3.	Toxicity Reduction Evaluation (TRE) Process	E-22
6.	Land Discharge Monitoring Requirements	E-24
6.1.	Monitoring Location LND-001	E-24
7.	Recycling Monitoring Requirements.....	E-25
7.1.	Recycled Water Monitoring Location REC-001	E-25
7.2.	Recycled Water Production and Use.....	E-27
8.	Receiving Water Monitoring Requirements – SURFACE WATER AND GROUNDWATER	E-29
8.1.	Monitoring Locations RSW-001	E-29
8.2.	Monitoring Locations RSW-003 and RSW-004.....	E-31
8.3.	Groundwater Monitoring Locations GW-001, GW-002, and GW-003	E-32
9.	Other Monitoring Requirements	E-34
9.1.	Filtration Process Monitoring	E-34
9.2.	Disinfection Process Monitoring for UV Disinfection System (Monitoring Location INT 002)	E-36
9.3.	Visual Monitoring (Monitoring Locations EFF-002, RSW-001, RSW-003, and RSW-004).....	E-37
9.4.	Sludge Monitoring (Monitoring Location BIO-001).....	E-37
10.	Reporting Requirements	E-37
10.1.	General Monitoring and Reporting Requirements.....	E-37
10.2.	Self-Monitoring Reports (SMRs)	E-37
10.3.	Discharge Monitoring Reports (DMRs)	E-42
10.4.	Other Reports	E-42
10.5.	Spill Notification	E-52

TABLE OF TABLES

Table E-1. Monitoring Station Locations.....	E-5
Table E-2. Influent Monitoring – Monitoring Location INF-001	E-8
Table E-3. Effluent Monitoring – Monitoring Location EFF-001 or EFF-005.....	E-9
Table E-4. Effluent Monitoring – Monitoring Location EFF-002 and EFF-005.....	E-10
Table E-5. Land Discharge Monitoring Requirements – Monitoring Location LND-001	E-24
Table E-6. Recycled Water Monitoring – Monitoring Location REC-001	E-26
Table E-7. Recycled Water Production and Use ¹	E-27
Table E-8. Receiving Water Monitoring - Monitoring Location RSW-001	E-29
Table E-9. Receiving Water Monitoring – Monitoring Locations RSW-003 and RSW-004	E-31
Table E 10. Groundwater Monitoring – Monitoring Location GW-003	E-33
Table E 11. Groundwater Monitoring – Monitoring Locations GW-001 and GW-002	E-33
Table E-12. Monitoring Periods and Reporting Schedule.....	E-38
Table E-13. Reporting Requirements for Special Provisions Reports	E-42

ATTACHMENT E – MONITORING AND REPORTING PROGRAM (MRP)

Section 308 of the federal Clean Water Act (CWA) and sections 122.41(h), (j)-(l), 122.44(i), and 122.48 of title 40 of the Code of Federal Regulations (40 C.F.R.) require that all NPDES permits specify monitoring and reporting requirements. Water Code sections 13267 and 13383 also authorize the Regional Water Board to establish monitoring, inspection, entry, reporting, and recordkeeping requirements. This MRP establishes monitoring, reporting, and recordkeeping requirements that implement the federal and California laws and/or regulations.

1. GENERAL MONITORING PROVISIONS

- 1.1. **Wastewater Monitoring Provision.** Composite samples may be taken by a proportional sampling device or by grab samples composited in proportion to flow. In compositing grab samples, the sampling interval shall not exceed 1 hour.
- 1.2. **Supplemental Monitoring Provision.** If the Permittee monitors any pollutant more frequently than required by this Order, using test procedures approved by 40 C.F.R. part 136 or as specified in this Order, the results of such monitoring shall be included in the calculation and reporting of the data submitted in the monthly and annual discharge monitoring reports.
- 1.3. **Laboratory Certification.** Laboratories analyzing monitoring samples shall be certified by the State Water Resources Control Board (State Water Board) in accordance with the provisions of Water Code section 13176 and must include quality assurance / quality control data with their analytical reports.

The Permittee may analyze pollutants with short hold times (e.g., pH, chlorine residual, etc.) with field equipment or its on-site laboratory provided that the Permittee has written standard operating procedures (SOPs) that identify quality assurance/quality control procedures to be followed to ensure accurate results. The Permittee shall keep a manual onsite containing the steps followed in this program and must demonstrate sufficient capability to adequately perform these field tests (e.g., qualified and trained employees, properly calibrated and maintained field instruments). The program shall conform to U.S. EPA guidelines or other approved procedures.

- 1.4. **Instrumentation and Calibration Provision.** All monitoring instruments and devices used by the Permittee to fulfill the prescribed monitoring program shall be properly maintained and calibrated as necessary to ensure their continued accuracy. All flow measurement devices shall be calibrated no less than the manufacturer's recommended intervals or one-year intervals, (whichever comes first) to ensure continued accuracy of the devices.

1.5. **Minimum Levels (ML) and Reporting Levels (RL).** U.S. EPA published regulations for the Sufficiently Sensitive Methods Rule (SSM Rule) which became effective September 18, 2015. Unless otherwise specified by this MRP, all monitoring shall be conducted according to test procedures established at 40 C.F.R. 136, *Guidelines Establishing Test Procedures for Analysis of Pollutants*. All analyses shall be conducted using the lowest practical quantitation limit achievable using U.S. EPA approved methods. For the purposes of the NPDES program, when more than one test procedure is approved under 40 C.F.R., part 136 for the analysis of a pollutant or pollutant parameter, the test procedure must be sufficiently sensitive as defined at 40 C.F.R. 122.21(e)(3) and 122.44(i)(1)(iv). A U.S. EPA-approved analytical method is sufficiently sensitive where:

- 1.5.1. The ML is at or below both the level of the applicable water quality criterion/objective and the permit limitation for the measured pollutant or pollutant parameter; or
- 1.5.2. In permit applications, the ML is above the applicable water quality criterion/objective, but the amount of the pollutant or pollutant parameter in a facility's discharge is high enough that the method detects and quantifies the level of the pollutant or pollutant parameter in the discharge; or

The method has the lowest ML of the U.S. EPA-approved analytical methods where none of the U.S. EPA-approved analytical methods for a pollutant can achieve the MLs necessary to assess the need for effluent limitations or to monitor compliance with a permit limitation.

Where effluent limitations are set below the lowest achievable quantitation limits, pollutants not detected at the lowest practical quantitation limits will be considered in compliance with effluent limitations. Analysis for toxics listed by the California Toxics Rule (CTR) shall also adhere to guidance and requirements contained in the *Policy for Implementation of Toxics Standards for Inland Surface Waters, Enclosed Bays, and Estuaries of California (2005) (SIP)*. However, there may be situations when analytical methods are published with MLs that are more sensitive than the MLs for analytical methods listed in the SIP. For instance, U.S. EPA Method 1631E for mercury is not currently listed in SIP Appendix 4, but it is published with an ML of 0.5 ng/L that makes it a sufficiently sensitive analytical method. Similarly, U.S. EPA Method 245.7 for mercury is published with an ML of 5 ng/L.

1.6. **Discharge Monitoring Report Quality Assurance (DMR-QA) Study.** The Permittee shall ensure that the results of the DMR-QA Study or the most recent Water Pollution Performance Evaluation Study are submitted annually to the State Water Board at the following address:

State Water Resources Control Board
 Quality Assurance Program Officer
 Office of Information Management and Analysis
 1001 I Street, Sacramento, CA 95814

2. MONITORING LOCATIONS

The Permittee shall establish the following monitoring locations to demonstrate compliance with the effluent limitations, discharge specifications, and other requirements in this Order:

Table E-1. Monitoring Station Locations

Discharge/ Distribution Point Name	Monitoring Location Name	Monitoring Location Description
-	INF-001	Untreated influent wastewater collected at the plant headworks at a representative point preceding primary treatment.
-	INT-001A	Location for monitoring the flow and influent turbidity to, and surface loading rate through, the tertiary wastewater treatment process filters.
--	INT-001B	Location for monitoring turbidity and effluent flow immediately following the tertiary wastewater treatment process filters.
--	INT-002	Location for monitoring ultraviolet light (UV) radiation dose and UV transmittance of the UV disinfection system.
001 (Discharge)	EFF-001	Location following tertiary wastewater treatment and disinfection where a representative sample of treated, disinfected effluent may be collected prior to storage in the Effluent Storage Pond (for evaluating technology-based effluent limitations). Latitude: 38° 29' 07" N Longitude: 122° 59' 54" W

Discharge/ Distribution Point Name	Monitoring Location Name	Monitoring Location Description
002 (Discharge)	EFF-002 ¹	Location following storage in the Effluent Storage Pond where a representative sample of treated, disinfected effluent may be collected prior to discharge to the Russian River (for evaluating water quality-based effluent limitations). This discharge point and monitoring location is the primary discharge point. Latitude: 38° 28' 56" N Longitude: 123° 00' 00" W
003	LND-001 ¹	Location where representative samples of treated, disinfected wastewater, to be land disposed through irrigation on the Burch property, can be collected, following all treatment and storage and immediately before its application for irrigation. Since irrigation application rates exceed hydraulic agronomic rates, this Order identifies this practice as land disposal rather than water recycling.
003	LND-001L	Irrigation flow to the Lower Burch land disposal property shall also be reported at this monitoring location. Latitude: 38° 29' 12" N Longitude: 122° 59' 49" W.
003	LND-001U	Irrigation flow to the Upper Burch land disposal property shall be reported at this monitoring location. Latitude: 38° 29' 01" N Longitude: 122° 59' 53" W
004 (Distribution)	REC-001 ¹	Location where representative samples of disinfected tertiary treated recycled water, to be used for recycled water irrigation at the Northwood Golf Course or other approved recycled water use sites, can be collected, following all treatment and on-site storage and immediately before its application for irrigation. Latitude: 38° 28' 42" N Longitude: 122° 59' 41" W

Discharge/ Distribution Point Name	Monitoring Location Name	Monitoring Location Description
005 (Discharge)	EFF-005	Location following tertiary wastewater treatment and disinfection where a representative sample of treated, disinfected effluent may be collected prior to direct discharge to the Russian River (for evaluating technology-based and water quality-based effluent limitations). This discharge point and monitoring location are for use if the storage pond needs to be taken off-line (i.e., for maintenance or to address issues that could lead to exceedance of effluent limitations). Latitude: 38° 28' 56" N Longitude: 123° 00' 00" W
--	BIO-001	A representative sample of the sludge or biosolids generated when removed for disposal.
--	RSW-001	Upstream receiving water monitoring location. Samples shall be representative of background conditions in the Russian River.
--	RSW-002 (Historic)	Downstream receiving water monitoring location. Samples shall be representative of conditions in the Russian River following introduction and mixing of effluent from the wastewater treatment Facility. Historic monitoring location replaced by RSW-004 as of October 2015. Latitude: 38.4812° N Longitude: 122.9955° W
--	RSW-003	Upstream receiving water monitoring location in the Russian River, immediately upstream of Discharge Point 002.
--	RSW-004	Downstream receiving water monitoring location in the Russian River approximately 90 feet downstream of Discharge Point 002.
--	GW-001	Downgradient groundwater monitoring well, located in the lower Burch irrigation area and approximately 225 feet down-gradient of monitoring well GW-002.
--	GW-002	Downgradient groundwater monitoring well, located at the up-gradient edge of the lower Burch irrigation area.

Discharge/ Distribution Point Name	Monitoring Location Name	Monitoring Location Description
--	GW-003	Upgradient groundwater monitoring well, located at the entrance to the Facility, approximately 500 feet upgradient of the lower Burch irrigation area.

Table Notes:

- Monitoring Locations EFF-002, LND-001, and REC-001 may be the same physical location, the sampling tap following the on-site Effluent Storage Pond. Unique sampling location names were given to differentiate the three different disposal methods which each have different monitoring requirements.

3. INFLUENT MONITORING REQUIREMENTS

3.1. Monitoring Location INF-001

- The Permittee shall monitor influent to the Facility at Monitoring Location INF-001 as follows:

Table E-2. Influent Monitoring – Monitoring Location INF-001

Parameter	Units	Sample Type	Minimum Sampling Frequency	Required Analytical Test Method
Influent Flow ¹	mgd	Meter	Continuous	-
Biochemical Oxygen Demand 5 day @ 20°C (BOD ₅)	mg/L	24-hr Composite	Weekly ²	Part 136 ³
Total Suspended Solids (TSS)	mg/L	24-hr Composite	Weekly ²	Part 136 ³

Table Notes:

- The Permittee shall report the mean daily and average monthly influent flow rates.
- Monitoring of BOD₅ and TSS in influent shall coincide with monitoring of these parameters in the effluent.
- Pollutants shall be analyzed using the analytical methods described in 40 C.F.R. part 136 or by methods approved by the Regional Water Board or State Water

Parameter	Units	Sample Type	Minimum Sampling Frequency	Required Analytical Test Method
Board, such as with the current edition of <i>Standard Methods for Examination of Water and Wastewater</i> (American Public Health Administration).				

4. EFFLUENT MONITORING REQUIREMENTS

4.1. Monitoring Location EFF-001 and EFF-005

4.1.1. The Permittee shall monitor disinfected tertiary treated wastewater to be discharged to the 3.5 million gallon Effluent Storage Pond at Monitoring Location EFF-001 or directly to the Russian River at Monitoring Location EFF-005, as follows:

Table E-3. Effluent Monitoring – Monitoring Location EFF-001 or EFF-005

Parameter	Units	Sample Type	Minimum Sampling Frequency	Required Analytical Test Method
Effluent Flow ^{1,2}	mgd	Meter	Continuous	-
BOD ₅	mg/L	24-hr Composite	Weekly ³	Part 136 ⁴
BOD Percent Removal	% Removal	Calculate	Monthly	-
TSS	mg/L	24-hr Composite	Weekly ³	Part 136 ⁴
TSS Percent Removal	% Removal	Calculate	Monthly	-
pH	Standard Units	Grab	Daily ⁵	Part 136 ⁴
Total Coliform Bacteria ⁶	MPN/100 mL	Grab	Daily ⁵	Part 136 ⁴

Table Notes:

1. Effluent flow may be monitored at Monitoring Location INT-001B.
2. The Permittee shall report the daily average and monthly average flows.
3. Accelerated monitoring (weekly monitoring frequency). If two consecutive weekly test results exceed an effluent limitation, the Permittee shall take two samples each of the 2 weeks following receipt of the second sample result. During the

Parameter	Units	Sample Type	Minimum Sampling Frequency	Required Analytical Test Method
<p>intervening period, the Permittee shall take steps to identify the cause of the exceedance and take steps needed to return to compliance.</p> <p>4. Pollutants shall be analyzed using the analytical methods described in 40 C.F.R. part 136 or by methods approved by the Regional Water Board or State Water Board, such as with the current edition of <i>Standard Methods for Examination of Water and Wastewater</i> (American Public Health Administration).</p> <p>5. Accelerated Monitoring (daily monitoring frequency). If a test result exceeds an effluent limitation, the Permittee shall increase monitoring frequency to a minimum of twice a day for a week to evaluate whether an exceedance is persisting. If two of more samples in a week exceed an effluent limitation, the Permittee shall take steps to identify the cause of the exceedance and take steps needed to return to compliance.</p> <p>6. The Permittee shall report calculated 7-day medians in addition to measured daily sampling results.</p>				

4.2. Monitoring Locations EFF-002 and EFF-005

4.2.1. The Permittee shall monitor disinfected tertiary treated wastewater when discharging to the Russian River at Monitoring Locations EFF-002 and EFF-005, as follows:

Table E-4. Effluent Monitoring – Monitoring Location EFF-002 and EFF-005

Parameter	Units	Sample Type	Minimum Sampling Frequency	Required Analytical Test Method
Effluent Flow ¹	mgd	Meter	Continuous	-
Discharge Dilution Rate	% of stream flow	Calculate	Daily	-
pH	standard units	Grab	Daily ^{2, 3}	Part 136 ⁴
<i>E. coli</i> Bacteria ^{14, 15}	MPN/100 mL	Grab	Weekly	Part 136 ⁴
Aluminum, Total Recoverable	µg/L	Grab	Monthly ¹⁶	Part 136 ⁴
Mercury, Total Recoverable ¹³	µg/L	Grab	Monthly	Part 136 ⁴

Parameter	Units	Sample Type	Minimum Sampling Frequency	Required Analytical Test Method
Ammonia Nitrogen, Total (as N)	mg/L	Grab	Monthly ³	Part 136 ⁴
Ammonia Nitrogen, Unionized (as N)	mg/L	Calculate	Monthly	Part 136 ⁴
Nitrate Nitrogen, Total (as N)	mg/L	Grab	Monthly	Part 136 ⁴
Nitrite Nitrogen, Total (as N)	mg/L	Grab	Monthly	Part 136 ⁴
Organic Nitrogen, Total (as N)	mg/L	Grab	Monthly	Part 136 ⁴
Nitrogen, Total (as N) ⁵	mg/L	Calculation	Monthly	---
Phosphorus, Total (as P)	mg/L	Grab	Monthly	Part 136 ⁴
Dissolved Oxygen	mg/L	Grab	Daily	Part 136 ⁴
Hardness, Total (as CaCO ₃)	mg/L	Grab	Once Per Permit Term ⁷	Part 136 ⁴
Specific Conductance @ 77°F	µmhos/cm	Grab	Monthly	Part 136 ⁴
Temperature	°C	Grab	Daily ³	Part 136 ⁴
Total Dissolved Solids	mg/L	Grab	Monthly	Part 136 ⁴
CTR Priority Pollutants ^{8,9}	µg/L	24-hr Composite ¹⁰	Once Per Permit Term	Part 136 ^{4, 11}
Acute Toxicity ^{6, 12}	% Survival, Pass or Fail, and % Effect	Grab	Annually	See Section 5.1 below
Chronic Toxicity ¹²	Pass or Fail, and % Effect	Grab	Annually	See Section 5.2 below

Parameter	Units	Sample Type	Minimum Sampling Frequency	Required Analytical Test Method
-----------	-------	-------------	----------------------------	---------------------------------

Table Notes:

1. The Permittee shall report the daily average and monthly average flows.
2. Accelerated Monitoring (daily monitoring frequency). If a test result exceeds an effluent limitation, the Permittee shall increase monitoring frequency to a minimum of twice a day for a week to evaluate whether an exceedance is persisting. If two of more samples in a week exceed an effluent limitation, the Permittee shall take steps to identify the cause of the exceedance and take steps needed to return to compliance.
3. Monitoring for effluent and receiving water pH and temperature shall be conducted concurrently with effluent sampling for ammonia.
4. Pollutants shall be analyzed using the analytical methods described in 40 C.F.R. part 136 or by methods approved by the Regional Water Board or State Water Board, such as with the current edition of *Standard Methods for Examination of Water and Wastewater* (American Public Health Administration).
5. Total Nitrogen shall be calculated using the results of ammonia nitrogen, total nitrate, total nitrite, and organic nitrogen.
6. Monitoring for acute whole effluent toxicity shall be concurrent with ammonia monitoring.
7. Monitoring for effluent and receiving water hardness shall be conducted concurrently with effluent and receiving water sampling for CTR priority pollutants.
8. Those pollutants identified by the California Toxics Rule at 40 C.F.R. section 131.38. The Permittee is not required to sample and analyze for asbestos. Hardness shall be monitored concurrently with the priority pollutant sample. Holding times for unpreserved cyanide shall not exceed one hour.
9. CTR priority pollutant sampling shall be completed no later than **March 1, 2025**. Effluent and receiving water monitoring shall occur concurrently.
10. CTR priority pollutant samples shall be collected using 24-hour composite sampling, except for pollutants that are volatile. Samples for volatile pollutants may be collected as a grab sample.

Parameter	Units	Sample Type	Minimum Sampling Frequency	Required Analytical Test Method
<p>11. Analytical methods must achieve the lowest ML specified in Appendix 4 of the SIP and, in accordance with section 2.4 of the SIP, the Permittee shall report the ML and MDL for each sample result. Total mercury samples shall be taken using clean hands/dirty hands procedures, as described in U.S. EPA method 1669: <i>Sampling Ambient Water for Trace Metals at EPA Water Quality Criteria Levels</i>, for collection of equipment blanks (section 9.4.4.2). The analysis of total mercury shall be by U.S. EPA method 1631 (Revision E) with a reporting limit of 0.5 ng/L (0.0005 µg/L).</p> <p>12. Whole effluent acute and chronic toxicity shall be monitored in accordance with the requirements of section 5 of this Monitoring and Reporting Program.</p> <p>13. Total mercury samples shall be taken using clean hands/dirty hands procedures, as described in U.S. EPA method 1669: <i>Sampling Ambient Water for Trace Metals at EPA Water Quality Criteria Levels</i>, for collection of equipment blanks (section 9.4.4.2). The analysis of total mercury shall be by U.S. EPA method 1631 (Revision E) with a reporting limit of 0.5 ng/L (0.0005 µg/L).</p> <p>14. With approval by the Executive Officer, the minimum sampling frequency may be modified or superseded to conform to the monitoring frequency within the approved Pathogen Special Study Work Plan required by section 6.3.2.2 of this Order.</p> <p>15. A minimum of five samples over a six-week period is necessary to calculate the geometric mean. See also Order section 7.8.3, Footnote 5.</p> <p>16. Accelerated Monitoring (monthly monitoring frequency). If a test result exceeds an effluent limitation, the Permittee shall take two more samples, one within 7 days and one within 14 days following receipt of the initial sample result. During the intervening period, the Permittee shall take steps to identify the cause of the exceedance and take steps needed to return to compliance.</p>				

5. WHOLE EFFLUENT TOXICITY TESTING REQUIREMENTS

5.1. Acute Toxicity Testing

The Permittee shall conduct acute toxicity testing in accordance with the following chronic toxicity testing requirements:

- 5.1.1. **Test Frequency.** The Permittee shall conduct acute WET testing in accordance with the schedule established by this MRP while discharging at Discharge Point 002, as summarized in Table E-4, above.

- 5.1.2. **Discharge In-stream Waste Concentration (IWC) for Acute Toxicity.** The IWC for this discharge is 100 percent effluent.¹
- 5.1.3. **Sample Volume and Holding Time.** The total sample volume shall be determined by the specific toxicity test method used. Sufficient sample volume shall be collected to perform the required toxicity test. All toxicity tests shall be conducted as soon as possible following sample collection. No more than 36 hours shall elapse before the conclusion of sample collection and test initiation.
- 5.1.4. **Freshwater Test Species and Test Methods.** The Permittee shall conduct the following acute toxicity tests in accordance with species and test methods in *Methods for Measuring the Acute Toxicity of Effluents and Receiving Waters to Freshwater and Marine Organisms* (U.S. EPA Report No. EPA-821-R-02-012, 5th edition or subsequent editions). In no case shall these species be substituted with another test species unless written authorization from the Executive Officer is received.
- 5.1.4.1. A 96-hour static renewal toxicity test with an invertebrate, the water flea, *Ceriodaphnia dubia* (Survival Test Method 2002.0).
- 5.1.4.2. A 96-hour static renewal toxicity test with a vertebrate, the rainbow trout, *Oncorhynchus mykiss* (Survival Test Method 2019.0).
- 5.1.5. **Species Sensitivity Screening.**
- 5.1.5.1. Species sensitivity screening was conducted on samples collected on February 26, 2020 using the fish and the invertebrate species identified in section 5.1.4, above. These samples were also analyzed for the parameters required for the discharge in Table E-4 of this Order. Both species passed with 100 percent survival. The data was also analyzed using the test of significant toxicity (TST) and passed with zero percent effect. The Permittee also conducted routine annual acute toxicity tests on *Ceriodaphnia dubia* during the term of the previous permit. The test result on February 10, 2016 resulted in 95 percent survival (a TST result of pass with a 5 percent effect).²

¹ The acute toxicity test shall be conducted using 100 percent effluent collected at Monitoring Location EFF-002.

² If the percent effect is equal to zero percent effect for each species, or all percent effect are the same value, in the species sensitivity test, the Permittee shall either use the species that was most sensitive during the previous permit term for routine monitoring or repeat the species sensitivity screening for all species to confirm the results of the first screening before selecting the most sensitive species to use for

- 5.1.5.2. The invertebrate species, *Ceriodaphnia dubia*, exhibited the highest “Percent (%) Effect” at the discharge IWC during species sensitivity screening, therefore shall be used for routine monitoring during the permit term.
- 5.1.5.3. Species sensitivity screening shall be completed again by **March 31, 2025**, so that the most sensitive species can be determined for the next permit term.
- 5.1.6. **Quality Assurance and Additional Requirements.** Quality assurance measures, instructions, and other recommendations and requirements are found in the test methods manual referenced in section 5.1.4, above. Additional requirements are specified below.
- 5.1.6.1. The discharge is subject to determination of “Pass” or “Fail” and “Percent (%) Effect” for chronic toxicity tests using the TST approach described in *National Pollutant Discharge Elimination System Test of Significant Toxicity Implementation Document* (EPA 833-R10-003, 2010), Appendix A, Figure A-1, and Table A-1. The null hypothesis (H_0) for the TST approach is: Mean discharge IWC response $\leq 0.75 \times$ Mean control response. A test result that rejects this null hypothesis is reported as “Pass”. A test result that does not reject this null hypothesis is reported as “Fail”. The relative “Percent (%) Effect” at the discharge IWC is defined and reported as: $((\text{Mean control response} - \text{Mean discharge IWC response}) \div \text{Mean control response}) \times 100$.
- 5.1.6.2. If the effluent toxicity test does not meet the minimum effluent or reference toxicant test acceptability criteria (TAC) specified in the referenced test method, then the Permittee shall re-sample and re-test within 14 days.
- 5.1.6.3. Dilution water and control water shall be laboratory water prepared and used as specified in the test methods manual. If dilution water and control water are different from test organism culture water, then a second control using culture water shall also be used.
- 5.1.6.4. Test procedures related to pH control, sample filtration, aeration, temperature control and sample dechlorination shall be performed in accordance with the U.S. EPA method and fully explained and justified in each acute toxicity report submitted to the Regional Water Board. The control of pH in acute toxicity tests is allowed, provided the test pH is maintained at the effluent pH measured at the time of sample collection, and the control of pH is done in a

routine monitoring. If two consecutive species sensitivity screening tests demonstrate that the percent effect for all species exhibit less than or equal to zero percent, the Permittee may select the species to be used for routine monitoring during the permit term.

manner that has the least influence on the test water chemistry and on the toxicity of other pH sensitive materials such as some heavy metals, sulfide and cyanide.

- 5.1.7. **Ammonia Toxicity.** The acute toxicity test shall be conducted without modifications to eliminate ammonia toxicity.
- 5.1.8. **Notification.** The Permittee shall notify the Regional Water Board verbally within 72 hours and in writing 14 days after receipt of test results exceeding the acute toxicity effluent limitation during regular or accelerated monitoring. The notification shall describe actions the Permittee has taken or will take to investigate and correct the cause(s) of toxicity. It may also include a status report on any actions required by this Order, with a schedule for actions not yet completed. If no actions have been taken, the reasons shall be given.
- 5.1.9. **Accelerated Monitoring Requirements.** If the result of any acute toxicity test fails to meet the single test minimum limitation (70 percent survival), and the testing meets all TAC, the Permittee shall take two more samples, one within 14 days and one within 21 days following receipt of the initial sample result. If any one of the additional samples do not comply with the three-sample median minimum limitation (90 percent survival), the Permittee shall initiate a Toxicity Reduction Evaluation (TRE) in accordance with section 5.3 of the MRP. If the two additional samples are in compliance with the acute toxicity requirement and testing meets all TAC, then a TRE will not be required. If the discharge stops before additional samples can be collected, the Permittee shall contact the Executive Officer within 21 days with a plan to demonstrate compliance with the effluent limitation.
- 5.1.10. **Reporting.** The Self-Monitoring Report (SMR) shall include a full laboratory report for each toxicity test (WET report). The WET report shall be prepared using the format and content of section 12 (Report Preparation) of *Methods for Measuring the Acute Toxicity of Effluents and Receiving Waters to Freshwater and Marine Organisms* (U.S. EPA Report No. EPA 821 R 02-012, 5th edition or subsequent editions), including:
- 5.1.10.1. The toxicity test results in percent (%) survival for the 100 percent effluent sample.
- 5.1.10.2. The toxicity test results for the TST approach, reported as “Pass” or “Fail” and “Percent (%) Effect” at the acute toxicity IWC for the discharge.
- 5.1.10.3. Water quality measurements for each toxicity test (e.g., pH, dissolved oxygen, temperature, conductivity, hardness, salinity, chlorine, ammonia).

5.1.10.4. TRE/Toxicity Identification Evaluation (TIE) results. The Executive Officer shall be notified no later than 30 days from completion of each aspect of TRE/TIE analyses.

5.1.10.5. Statistical program (e.g., TST calculator, CETIS, etc.) output results for each toxicity test.

5.2. Chronic Toxicity Testing

The Permittee shall conduct chronic toxicity testing in accordance with the following chronic toxicity testing requirements:

5.2.1. **Test Frequency.** The Permittee shall conduct chronic WET testing in accordance with the schedule established by this MRP while discharging at Discharge Point 002, as summarized in Table E-4, above.

5.2.2. **Discharge In-stream Waste Concentration (IWC) for Chronic Toxicity.** The IWC for this discharge is 100 percent effluent.³

5.2.3. **Sample Volume and Holding Time.** The total sample volume shall be determined by the specific toxicity test method used. Sufficient sample volume shall be collected to perform the required toxicity test. All toxicity tests shall be conducted as soon as possible following sample collection. For toxicity tests requiring renewals, a minimum of three daily grab samples shall be collected (one sample per 24-hour period). The lapsed time (holding time) from sample collection to first use of each sample must not exceed 36 hours.

5.2.4. **Freshwater Test Species and Test Methods.** The Permittee shall conduct the following chronic toxicity tests in accordance with species and test methods in *Short-Term Methods for Estimating the Chronic Toxicity of Effluents and Receiving Water to Freshwater Organisms* (U.S. EPA Report No. EPA-821-R-02-013, or subsequent editions). In no case shall these species be substituted with another test species unless written authorization from the Executive Officer is received.

5.2.4.1. A 7-day static renewal toxicity test with a vertebrate, the fathead minnow, *Pimephales promelas* (Larval Survival and Growth Test Method 1000.0).

³ The chronic toxicity test shall be conducted using a series of five dilutions and a control. The series shall consist of the following dilutions: 12.5, 25, 50, 75, and 100 percent. Compliance determination will be based on the IWC (100 percent effluent) and a control as further described in Fact Sheet section 4.3.5.3.

5.2.4.2. A static renewal toxicity test with an invertebrate, the water flea, *Ceriodaphnia dubia* (Survival and Reproduction Test Method 1002.0).

5.2.4.3. A 96-hour static renewal toxicity test with a plant, the green algae, *Selenastrum capricornutum* (also named *Raphidocelis subcapitata*) (Growth Test Method 1003.0).

5.2.5. Species Sensitivity Screening.

5.2.5.1. Species sensitivity screening was conducted in February and March 2020. The Permittee collected two sets of effluent samples, one set beginning on February 24, 2020 and the second set beginning on March 16, 2020, and concurrently conducted three chronic toxicity tests using the fish, the invertebrate, and the algae species identified in section 5.2.4, above. These samples were also analyzed for the parameters required for the discharge in Table E-4 of this Order. All three species passed in both sets of tests.

The data was also analyzed using the test of significant toxicity (TST) and passed. The fish species, *Pimephales promelas*, exhibited the highest “Percent (%) Effect” at the discharge IWC during species sensitivity screening, therefore shall be used for routine monitoring during the permit term.⁴

5.2.5.2. Species sensitivity screening shall be completed again by **March 31, 2025**, so that the most sensitive species can be determined for the next permit term.

5.2.6. Quality Assurance and Additional Requirements. Quality assurance measures, instructions, and other recommendations and requirements are found in the test methods manual referenced in section 5.2.4, above. Additional requirements are specified below.

5.2.6.1. The discharge is subject to determination of “Pass” or “Fail” and “Percent (%) Effect” for chronic toxicity tests using the TST approach described in *National*

⁴ If the percent effect is less than or equal to zero percent effect for each species, or all percent effect are the same value, in the species sensitivity screening test, the Permittee shall either use the species that was most sensitive during the previous permit term for routine monitoring or repeat the species sensitivity screening for all species to confirm the results of the first screening before selecting the most sensitive species to use for routine monitoring. If two consecutive species sensitivity screening tests demonstrate that the percent effect for all species exhibit less than or equal to zero percent, the Permittee may select the species to be used for routine monitoring during the permit term.

Pollutant Discharge Elimination System Test of Significant Toxicity Implementation Document (EPA 833-R10-003, 2010), Appendix A, Figure A-1, and Table A-1. The null hypothesis (H_0) for the TST approach is mean discharge IWC response $0.75 \times$ mean control response. A test result that rejects this null hypothesis is reported as "Pass". A test result that does not reject this null hypothesis is reported as "Fail". The relative "Percent (%) Effect" at the discharge IWC is defined and reported as: $((\text{mean control response} - \text{mean discharge IWC response}) \div \text{mean control response}) \times 100$.

- 5.2.6.2. If the effluent toxicity test does not meet the minimum effluent or reference toxicant test acceptability criteria (TAC) specified in the referenced test method, then the Permittee shall re-sample and re-test within 14 days.
- 5.2.6.3. Dilution water and control water shall be laboratory water prepared and used as specified in the test methods manual. If dilution water and control water are different from test organism culture water, then a second control using culture water shall also be used.
- 5.2.6.4. Monthly reference toxicant testing is sufficient. All reference toxicant test results should be reviewed and reported.
- 5.2.6.5. The Permittee shall perform toxicity tests on final effluent samples. Chlorine and ammonia shall not be removed from the effluent sample prior to toxicity testing, unless explicitly authorized under this section of the MRP and the rationale is explained in the Fact Sheet (Attachment F).
- 5.2.7. **Ammonia Removal.** Except with prior approval from the Executive Officer of the Regional Water Board, ammonia shall not be removed from bioassay samples. The Permittee must demonstrate the effluent toxicity is caused by ammonia because of increasing test pH when conducting the toxicity test. It is important to distinguish the potential toxic effects of ammonia from other pH sensitive chemicals, such as certain heavy metals, sulfide, and cyanide. The following may be steps to demonstrate that the toxicity is caused by ammonia and not other toxicants before the Executive Officer would allow for control of pH in the test.
 - 5.2.7.1. There is consistent toxicity in the effluent and the maximum pH in the toxicity test is in the range to cause toxicity due to increased pH.
 - 5.2.7.2. Chronic ammonia concentrations in the effluent are greater than 4 mg/L total ammonia.
 - 5.2.7.3. Conduct graduated pH tests as specified in the toxicity identification evaluation methods. For example, mortality should be higher at pH 8 and lower at pH 6.

- 5.2.7.4. Treat the effluent with a zeolite column to remove ammonia. Mortality in the zeolite treated effluent should be lower than the non-zeolite treated effluent. Then add ammonia back to the zeolite-treated samples to confirm toxicity due to ammonia.

When it has been demonstrated that toxicity is due to ammonia because of increasing test pH, pH may be controlled using appropriate procedures which do not significantly alter the nature of the effluent.

- 5.2.8. **Notification.** The Permittee shall notify the Regional Water Board verbally within 72 hours and in writing within 14 days after the receipt of a result of “Fail” during routine or accelerated monitoring.

- 5.2.9. **Accelerated Monitoring Requirements.** Accelerated monitoring for chronic toxicity is triggered when a chronic toxicity test, analyzed using the TST approach, results in “Fail” and the “Percent Effect” is ≥ 0.50 . Within 24 hours of the time the Permittee becomes aware of a summary result of “Fail”, the Permittee shall implement an accelerated monitoring schedule consisting of four toxicity tests—consisting of 5-effluent concentrations (including the discharge IWC) and a control—conducted at approximately 2-week intervals, over an 8 week period. If each of the accelerated toxicity tests results is “Pass,” the Permittee shall return to routine monitoring for the next monitoring period. If one of the accelerated toxicity tests results is “Fail”, the Permittee shall immediately implement the TRE Process conditions set forth in section 5.3, below.

5.2.10. Reporting

- 5.2.10.1. **Routine Reporting.** Chronic toxicity monitoring results shall be submitted with the monthly SMR for the month in which chronic toxicity monitoring was performed. Routine reporting shall include the following in order to demonstrate compliance with requirements of this Order:

- 5.2.10.1.1. WET reports shall include the contracting laboratory’s complete report provided to the Permittee and shall be consistent with the appropriate “Report Preparation and Test Review” sections of the methods manual and this MRP. The WET test reports shall contain a narrative report that includes details about WET test procedures and results, including the following:

- 5.2.10.1.1.1. Receipt and handling of the effluent sample that includes a tabular summary of initial water quality characteristics (e.g., pH, dissolved oxygen, temperature, conductivity, hardness, salinity, chlorine, ammonia);

- 5.2.10.1.1.2. The source and make-up of the lab control/diluent water used for the test;

- 5.2.10.1.1.3. Any manipulations done to lab control/diluent and effluent such as filtration, nutrient addition, etc.;
- 5.2.10.1.1.4. Tabular summary of test results for control water and each effluent dilution and statistics summary to include calculation of the NOEC, TUc, and IC25;
- 5.2.10.1.1.5. Identification of any anomalies or nuances in the test procedures or results;
- 5.2.10.1.1.6. WET test results shall include, at a minimum, for each test:
- 5.2.10.1.1.6.1. Sample date(s);
- 5.2.10.1.1.6.2. Test initiation date;
- 5.2.10.1.1.6.3. Test species;
- 5.2.10.1.1.6.4. Determination of “Pass” or “Fail” and “Percent Effect” following the TST hypothesis testing approach in National Pollutant Discharge Elimination System Test of Significant Toxicity Implementation Document (EPA 833-R-10-003, 2010). The “Percent Effect” shall be calculated as follows:
- “Percent Effect” (or Effect, in %) = ((Control mean response – IWC mean response) ÷ Control mean response) x 100
- 5.2.10.1.1.6.5. End point values for each dilution (e.g., number of young, growth rate, percent survival);
- 5.2.10.1.1.6.6. NOEC value(s) in percent effluent;
- 5.2.10.1.1.6.7. IC15, IC25, IC40, and IC50 values (or EC15, EC25...etc.) in percent effluent;
- 5.2.10.1.1.6.8. TUc values (100/NOEC);
- 5.2.10.1.1.6.9. Mean percent mortality (±s.d.) after 96 hours in 100 percent effluent (if applicable);
- 5.2.10.1.1.6.10. NOEC and LOEC values for reference toxicant test(s);
- 5.2.10.1.1.6.11. IC50 or EC50 value(s) for reference toxicant test(s);
- 5.2.10.1.1.6.12. Available water quality measurements for each test (e.g., pH, dissolved oxygen, temperature, conductivity, hardness, salinity, ammonia);
- 5.2.10.1.1.6.13. Statistical methods used to calculate endpoints;

5.2.10.1.1.6.14. The statistical program (e.g., TST calculator, CETIS, etc.) output results, which includes the calculation of percent minimum significant difference (PMSD); and

5.2.10.1.1.6.15. Results of applicable reference toxicant data with the statistical output page identifying the species, NOEC, LOEC, type of toxicant, dilution water used, concentrations used, PMSD and dates tested; the reference toxicant control charts for each endpoint, to include summaries of reference toxicant tests performed by the contracting laboratory; and any information on deviations from standard test procedures or problems encountered in completing the test and how the problems were resolved.

5.2.10.2. **TRE/TIE Results.** The Executive Officer shall be notified no later than 30 days from completion of each aspect of TRE/TIE analyses. TRE/TIE results shall be submitted to the Regional Water Board within 60 days of completion.

5.3. Toxicity Reduction Evaluation (TRE) Process

5.3.1. **TRE Work Plan.** The Permittee submitted a TRE Work Plan to the Regional Water Board on May 5, 2004. By **December 1, 2021**, the Permittee's TRE Work Plan shall be reviewed for consistency with permit requirements and the Permittee's procedures and updated as necessary in order to remain current and applicable to the discharge and requirements of this Order.

The Permittee shall notify the Regional Water Board of this review and submit any revisions of the TRE Work Plan by **March 1, 2022**, to be ready to respond to toxicity events. The TRE Work Plan shall describe the steps the Permittee intends to follow if toxicity is detected, and should include at least the following items:

5.3.1.1. A description of the investigation and evaluation techniques that would be used to identify potential causes and sources of toxicity, effluent variability, and treatment system efficiency.

5.3.1.2. A description of the facility's methods of maximizing in-house treatment efficiency, good housekeeping practices, and a list of all chemicals used in the operation of this Facility.

5.3.1.3. If a toxicity identification evaluation (TIE) is necessary, an indication of the person who would conduct the TIEs (i.e., an in-house expert or an outside contractor).

5.3.2. **Preparation and Implementation of a Detailed TRE Work Plan.** If one of the accelerated toxicity tests described in sections 5.1.8 and 5.2.8, above, results in

“Fail”, the Permittee shall immediately initiate a TRE using EPA manual *Generalized Methodology for Conducting Industrial Toxicity Reduction Evaluations* (EPA/600/2-88/070, 1989) and within 30 days of receipt submit the accelerated monitoring result to the Regional Water Board Executive Officer. The Permittee shall also submit a Detailed TRE Work Plan, which shall follow the generic TRE Work Plan revised as appropriate for the toxicity event described in sections 5.1.8 and 5.2.8 of this MRP. The Detailed TRE Work Plan shall include the following information, and comply with additional conditions set by the Regional Water Board Executive Officer:

- 5.3.2.1. Further actions by the Permittee to investigate, identify, and correct causes of toxicity.
- 5.3.2.2. Actions the Permittee will take to mitigate effects of the discharge and prevent the recurrence of toxicity.
- 5.3.2.3. A schedule for these actions, progress reports, and the final report.
- 5.3.3. **TIE Implementation.** The Permittee may initiate a TIE as part of a TRE to identify the causes of toxicity using the same species and test methods and, as guidance, EPA manuals: *Methods for Aquatic Toxicity Identification Evaluations: Phase I Toxicity Characterization Procedures* (EPA/600/6-91/003, 1991); *Methods for Aquatic Toxicity Identification Evaluations, Phase II Toxicity Identification Procedures for Samples Exhibiting Acute and Chronic Toxicity* (EPA/600/R-92/080, 1993); *Methods for Aquatic Toxicity Identification Evaluations, Phase III Toxicity Confirmation Procedures for Samples Exhibiting Acute and Chronic Toxicity* (EPA/600/R-92/081, 1993); and *Marine Toxicity Identification Evaluation (TIE): Phase I Guidance Document* (EPA/600/R-96-054, 1996). The TIE should be conducted on the species demonstrating the most sensitive toxicity response.
- 5.3.4. Many recommended TRE elements parallel required or recommended efforts for source control, pollution prevention, and storm water control programs. TRE efforts should be coordinated with such efforts. As toxic substances are identified or characterized, the Permittee shall continue the TRE by determining the sources and evaluating alternative strategies for reducing or eliminating the substances from the discharge. All reasonable steps shall be taken to reduce toxicity to levels consistent with toxicity evaluation parameters.
- 5.3.5. The Permittee shall conduct routine effluent monitoring for the duration of the TRE process. Additional accelerated monitoring and TRE work plans are not required once a TRE has begun.
- 5.3.6. The Regional Water Board recognizes that toxicity may be episodic and identification of the causes and reduction of sources of toxicity may not be

successful in all cases. The TRE may be ended at any stage if monitoring finds there is no longer toxicity.

6. LAND DISCHARGE MONITORING REQUIREMENTS

6.1. Monitoring Location LND-001

6.1.1. The Permittee shall monitor disinfected tertiary treated wastewater when discharging to the Burch property at Monitoring Location LND-001, as follows:

Table E-5. Land Discharge Monitoring Requirements – Monitoring Location LND-001

Parameter	Units	Sample Type	Minimum Sampling Frequency	Required Analytical Test Method
Effluent Flow ¹	mgd	Meter	Continuous	-
pH	standard units	Grab	Daily ²	Part 136 ³
Nitrate Nitrogen, Total (as N)	mg/L	Grab	Monthly ⁴	Part 136 ³
Nitrite Nitrogen, Total (as N)	mg/L	Grab	Monthly	Part 136 ³
Organic Nitrogen, Total (as N)	mg/L	Grab	Monthly	Part 136 ³
Ammonia Nitrogen (as N)	mg/L	Grab	Monthly	Part 136 ³
Nitrogen, Total (as N) ⁵	mg/L	Calculation	Monthly	Part 136 ³
Total Dissolved Solids (TDS)	mg/L	Grab	Monthly	Part 136 ³
Sodium	mg/L	Grab	Annual ^{6,7}	Part 136 ³
Aluminum, Total Recoverable	mg/L	Grab	Monthly ⁴	Part 136 ³

Table Notes:

1. Each month the Permittee shall report the number of days that treated wastewater was used for irrigation on the Lower Burch property (LND-001L) and Upper Burch property (LND-001U), as well as the average and maximum daily flow rate.

Parameter	Units	Sample Type	Minimum Sampling Frequency	Required Analytical Test Method
<p>2. Accelerated monitoring (daily monitoring frequency). If a test result exceeds an effluent limitation, the Permittee shall increase the monitoring frequency to a minimum of twice a day for a week to evaluate whether an exceedance is persisting. If two or more samples in a week exceed an effluent limitation, the Permittee shall take steps to identify the cause of the exceedance and take steps needed to return to compliance.</p> <p>3. Pollutants shall be analyzed using the analytical methods described in 40 C.F.R. part 136 or by methods approved by the Regional Water Board or State Water Board, such as with the current edition of <i>Standard Methods for Examination of Water and Wastewater</i> (American Public Health Administration).</p> <p>4. Accelerated monitoring (monthly monitoring frequency). If a test result exceeds an effluent limitation, the Permittee shall take two more samples, one within 7 days and one within 14 days following receipt of the initial sample result. During the intervening period, the Permittee shall take steps to identify the cause of the exceedance and take steps needed to return to compliance.</p> <p>5. Total Nitrogen shall be calculated using the results of ammonia nitrogen, total nitrate, total nitrite, and organic nitrogen.</p> <p>6. Annual monitoring for sodium shall occur in September to reflect the time of year when salts are typically highest in the effluent based on previous monitoring.</p> <p>7. Accelerated monitoring for sodium shall be implemented if an annual sodium result exceeds the sodium discharge specification of 60 mg/L. Accelerated monitoring shall consist of weekly monitoring for the remainder of the land discharge season.</p>				

6.1.2. Visual observations shall be conducted during and immediately after any discharge to the irrigation system, and shall include a record of any odors, evidence of surface runoff or spray mist leaving the property boundaries, or other signs of malfunction or improper operation. Visual observations shall be recorded and included in the Permittee's monthly SMRs.

7. RECYCLING MONITORING REQUIREMENTS

7.1. Recycled Water Monitoring Location REC-001

7.1.1. The Permittee shall monitor disinfected tertiary recycled water whenever recycled water is distributed to the recycled water system at Monitoring Location REC-001 as follows:

Table E-6. Recycled Water Monitoring – Monitoring Location REC-001

Parameter	Units	Sample Type	Minimum Sampling Frequency	Required Analytical Test Method
Effluent Flow ¹	mgd	Meter	Continuous	--
Ammonia Nitrogen, Total (as N) ²	mg/L	Grab	Monthly	Part 136 ³
Nitrate Nitrogen, Total (as N) ²	mg/L	Grab	Monthly ⁴	Part 136 ³
Nitrite Nitrogen, Total (as N) ²	mg/L	Grab	Monthly	Part 136 ³
Organic Nitrogen, Total (as N) ²	mg/L	Grab	Monthly	Part 136 ³
Nitrogen, Total (as N) ⁵	mg/L	Calculation	Monthly	Part 136 ³
Sodium	mg/L	Grab	Annual ⁶	Part 136 ³

Table Notes:

1. Each month the Permittee shall report the number of days that disinfected tertiary recycled water was used for recycled water irrigation at the Northwood Golf Course or other approved recycled water use sites, as well as the average and maximum daily flow rate.
2. Monitoring for ammonia, nitrate, nitrite, and total organic nitrogen is for the purpose of determining total nitrogen concentration for agronomic rate calculations.
3. Pollutants shall be analyzed using the analytical methods described in 40 C.F.R. part 136 or by methods approved by the Regional Water Board or State Water Board, such as with the current edition of *Standard Methods for Examination of Water and Wastewater* (American Public Health Administration).
4. Accelerated monitoring (monthly monitoring frequency). If a test result exceeds an effluent limitation, the Permittee shall take two more samples, one within 7 days and one within 14 days following receipt of the initial sample result. During the intervening period, the Permittee shall take steps to identify the cause of the exceedance and take steps needed to return to compliance.
5. Total Nitrogen shall be calculated using the results of ammonia nitrogen, total nitrate, total nitrite, and organic nitrogen.

Parameter	Units	Sample Type	Minimum Sampling Frequency	Required Analytical Test Method
6. Annual monitoring for sodium shall occur in September to reflect the time of year when salts are typically highest in the effluent based on previous monitoring.				

7.1.2. The Permittee shall comply with Water Recycling Requirements and Provisions contained in Attachment G of this Order.

7.2. Recycled Water Production and Use

7.2.1. Recycled water quality characteristics and precipitation shall be used to ascertain nitrogen loading rates at each recycled water use site.

7.2.2. The frequency of use area inspections shall be based on the complexity and risk of each use area.

7.2.3. Reporting of the required monitoring shall be provided annually in the Annual Recycled Water Report to the Regional Water Board, and annually to recycled water users.

7.2.4. The following information shall be reported for each use site or use site type:

Table E-7. Recycled Water Production and Use ¹

Parameter	Units	Sample Type	Monitoring/ Observation Frequency ²
Recycled Water User	--	--	--
Recycled Water Flow ³	gpd ⁴	Meter ⁵	Monthly
Acreage Applied	acres	Calculated	Annually
Application Rate (hydraulic)	inches/acre/year	Calculated	Annually
Total Nitrogen Application Rate _{6, 7}	lbs/acre/year	Calculated	Annually
Rainfall	inches	Gauge	Daily
Soil Saturation/Ponding	--	Observation	Monthly
Discharge Off-Site	--	Observation	Monthly
Nuisance/Vectors	--	Observation	Monthly
Notification Signs ⁸	--	Observe	Monthly

Parameter	Units	Sample Type	Monitoring/ Observation Frequency ²
Maximum Allowable Hydraulic Agronomic Rate ⁹	inches	Calculation	--
Maximum Allowable Nitrogen Agronomic Rate	lbs	Calculation	--

Table Notes:

1. Recycled water production and use area monitoring shall be reported with the annual report (section 10.4.4 of this MRP). Non-compliance incidents shall be reported as specified in Order section 6.1.2.2 and section 10.4.4 of this MRP.
2. Or less frequently if approved by the Regional Water Board Executive Officer through modification of this MRP.
3. Estimation of the volume of recycled water shall not include other potable or non-potable “make-up” water used in conjunction with recycled water.
4. gpd denotes gallons per day.
5. Meter requires meter reading, a pump run time meter, or other approved method.
6. Nitrogen application rate shall consider nitrogen content of the recycled water, based on effluent monitoring data.
7. Nitrogen concentrations shall be calculated and reported “as N”. For example, nitrate-nitrogen = 27 mg/L as NO₃ shall be converted and reported as nitrate-nitrogen = 6.1 mg/L as N using a conversion factor of 14.067 (N)/62.0049 (NO₃).
8. Notification signs shall be consistent with the requirements of California Code of Regulations, title 22, section 60310(g).
9. Maximum allowable hydraulic agronomic rates for each recycled water use site will be calculated as follows:

$$\text{Irrigation water requirement} = \frac{(\text{ETo} * \text{Kp}) - \text{Pe}_{\text{eff}}}{(1 - \text{LR}) * \text{Eu}}$$

Where:

ETo = Reference evapotranspiration is defined as the amount of water used by the plants (transpiration) and evaporated from the soil (evaporation) (and is based on the consumptive water use of a local grass field, measured by the California Department of Water Resources, CIMIS database. It is measured in inches by Santa Rosa CIMIS weather station #83.

Kp = Crop growth coefficient for golf course turf, 0.8

Parameter	Units	Sample Type	Monitoring/ Observation Frequency ²
<p>Pe_{eff} = Effective precipitation (amount of rainfall in inches available to golf course turf, 70% of local rainfall measured at the WWTF)</p> <p>LR = Leaching Requirement, 0% (a conservative estimate) is the fraction of irrigation water (irrigation plus precipitation), required to leach the excess salt out of the root zone, to reduce salt stress on the plant root zone. LR is based on the salt concentration of the applied water and the salt tolerance of the crop.</p> <p>Eu = Unit application efficiency for golf course rotary sprinklers, 80%</p>			

8. RECEIVING WATER MONITORING REQUIREMENTS – SURFACE WATER AND GROUNDWATER

8.1. Monitoring Locations RSW-001

8.1.1. The Permittee shall monitor the Russian River at Monitoring Location RSW-001 during periods of discharge as follows:

Table E-8. Receiving Water Monitoring - Monitoring Location RSW-001

Parameter	Units	Sample Type	Minimum Sampling Frequency	Required Analytical Test Method
Flow	mgd	Gauge ¹	Daily	--
pH	standard units	Grab	Weekly ^{2, 3}	Part 136 ⁴
Aluminum, Total Recoverable	mg/L	Grab	Monthly ³	Part 136 ⁴
Ammonia Nitrogen, Total (as N)	mg/L	Grab	Semiannually	Part 136 ⁴
Ammonia Nitrogen, Unionized (as N)	mg/L	Grab	Semiannually	Part 136 ⁴
Mercury, Total Recoverable ⁹	µg/L	Grab	Monthly	Part 136 ⁴

Parameter	Units	Sample Type	Minimum Sampling Frequency	Required Analytical Test Method
Nitrate Nitrogen, Total (as N)	mg/L	Grab	Semiannually	Part 136 ⁴
Organic Nitrogen, Total (as N)	mg/L	Grab	Semiannually	Part 136 ⁴
Phosphorus, Total as P	mg/L	Grab	Semiannually	Part 136 ⁴
Dissolved Organic Carbon	mg/L	Grab	Monthly ³	Part 136 ⁴
Dissolved Oxygen	mg/L	Grab	Weekly	Part 136 ⁴
Hardness, Total (as CaCO ₃)	mg/L	Grab	Monthly ^{3, 5}	Part 136 ⁴
Specific Conductance @ 77°F	µmhos/cm	Grab	Monthly ⁶	Part 136 ⁴
Temperature	°C	Grab	Weekly ²	Part 136 ⁴
Total Dissolved Solids	mg/L	Grab	Monthly ⁶	Part 136 ⁴
Turbidity	NTU	Grab	Weekly	Part 136 ⁴
CTR Priority Pollutants ^{7, 8}	µg/L	Grab	Once Per Permit Term	Part 136 ^{4, 9}

Table Notes:

1. The flow rate shall be determined using the flow at USGS Gauge No. 11-4670.00 at the Hacienda Bridge and compared to the daily discharge rate to determine compliance with Discharge Prohibition 3.10 of the Order. For each month during the discharge season, peak daily and average daily flow shall be reported.
2. Monitoring for effluent and receiving water pH and temperature shall be conducted concurrently with effluent sampling for ammonia.
3. Monitoring for receiving water aluminum, pH, dissolved organic carbon, and hardness shall be conducted concurrently with effluent monitoring for aluminum.
4. Pollutants shall be analyzed using the analytical methods described in 40 C.F.R. part 136 or by methods approved by the Regional Water Board or State Water

Parameter	Units	Sample Type	Minimum Sampling Frequency	Required Analytical Test Method
<p>Board, such as with the current edition of <i>Standard Methods for Examination of Water and Wastewater</i> (American Public Health Administration).</p> <p>5. Monitoring for effluent and receiving water hardness shall be conducted concurrently with effluent and receiving water sampling for CTR priority pollutants.</p> <p>6. If monitoring results do not vary significantly after 2 years of monitoring, the monitoring frequency may be reduced to twice per year.</p> <p>7. Those pollutants identified by the California Toxics Rule at 40 C.F.R. section 131.38. The Permittee is not required to sample and analyze for asbestos. Hardness shall be monitored concurrently with the priority pollutant sample. Holding times for unpreserved cyanide shall not exceed one hour.</p> <p>8. CTR priority pollutant sampling shall be completed no later than March 1, 2025. Effluent and receiving water monitoring shall occur concurrently.</p> <p>9. Analytical methods must achieve the lowest ML specified in Appendix 4 of the SIP and, in accordance with section 2.4 of the SIP, the Permittee shall report the ML and MDL for each sample result. Total mercury samples shall be taken using clean hands/dirty hands procedures, as described in U.S. EPA method 1669: <i>Sampling Ambient Water for Trace Metals at EPA Water Quality Criteria Levels</i>, for collection of equipment blanks (section 9.4.4.2). The analysis of total mercury shall be by U.S. EPA method 1631 (Revision E) with a reporting limit of 0.5 ng/L (0.0005 µg/L).</p>				

8.2. Monitoring Locations RSW-003 and RSW-004

8.2.1. The Permittee shall monitor the Russian River at Monitoring Locations RSW-003 and RSW-004, during periods of discharge as follows:

Table E-9. Receiving Water Monitoring – Monitoring Locations RSW-003 and RSW-004

Parameter	Units	Sample Type	Minimum Sampling Frequency	Required Analytical Test Method
pH	standard units	Meter	4 Samples (1/year) ^{1, 2}	Part 136 ³
Dissolved Oxygen	mg/L	Grab or Meter	4 Samples (1/year) ^{1, 2}	Part 136 ³

Parameter	Units	Sample Type	Minimum Sampling Frequency	Required Analytical Test Method
Specific Conductance @ 77°F	µmhos/cm	Grab or Meter	4 Samples (1/year) ^{1, 2}	Part 136 ³
Temperature	°C	Meter	4 Samples (1/year) ^{1, 2}	Part 136 ³
Total Dissolved Solids	mg/L	Grab or Meter	4 Samples (1/year) ^{1, 2}	Part 136 ³
Turbidity	NTU	Grab or Meter	4 Samples (1/year) ^{1, 2}	Part 136 ³
<i>E. coli</i> bacteria	MPN/100 mL	Grab	4	Part 136 ³

Table Notes:

1. Samples shall be collected every 15 minutes for 1 hour during the month of October or November during a period of discharge.
2. Monitoring for upstream and downstream receiving water pH, dissolved oxygen, specific conductance, temperature, dissolved solids, and turbidity at Monitoring Locations RSW-003 and RSW-004 shall be conducted on the same day as upstream receiving water monitoring at Monitoring Location RSW-001.
3. Pollutants shall be analyzed using the analytical methods described in 40 C.F.R. part 136 or by methods approved by the Regional Water Board or State Water Board, such as with the current edition of *Standard Methods for Examination of Water and Wastewater* (American Public Health Administration).
4. Monitoring receiving water for *E. coli* bacteria may be required/conducted in accordance with the approved Pathogen Study or as part of a group monitoring effort to assess achievement of bacteria water quality objectives.

8.3. Groundwater Monitoring Locations GW-001, GW-002, and GW-003

8.3.1. The Permittee shall monitor groundwater to assess impacts of land discharge in the lower Burch disposal area at Monitoring Locations GW-001, GW-002, and GW-003 as follows:

8.3.1.1. The upgradient well, GW-003 shall be monitored as follows:

Table E 10. Groundwater Monitoring – Monitoring Location GW-003

Parameter	Units	Sample Type	Minimum Sampling Frequency ¹	Required Analytical Test Method
Depth to Groundwater	inches	Measure	Quarterly ²	--
pH	standard units	Grab	Twice per year ³	Part 136 ⁴
Nitrate Nitrogen, Total (as N)	mg/L	Grab	Twice per year ³	Part 136 ⁴
Total Dissolved Solids (TDS)	mg/L	Grab	Twice per year ³	Part 136 ⁴
Sodium	mg/L	Grab	Twice per year ³	Part 136 ⁴
Chloride	mg/L	Grab	Twice per year ³	Part 136 ⁴
Aluminum, Total Dissolved	mg/L	Grab	Twice per year ³	Part 136 ⁴

Table Notes:

1. The groundwater monitoring frequency may be increased or decreased based on the results of monitoring conducted during the term of this MRP.
2. Quarterly depth to groundwater monitoring shall occur in the months of February, May, August, and November.
3. Twice per year monitoring shall occur in the months of May and August.
4. Pollutants shall be analyzed using the analytical methods described in 40 C.F.R. part 136 or by methods approved by the Regional Water Board or State Water Board, such as with the current edition of *Standard Methods for Examination of Water and Wastewater* (American Public Health Administration).

8.3.1.2. The downgradient wells, GW-001 and GW-002 shall be monitored as follows:

Table E 11. Groundwater Monitoring – Monitoring Locations GW-001 and GW-002

Parameter	Units	Sample Type	Minimum Sampling Frequency ¹	Required Analytical Test Method
Depth to Groundwater	inches	Measure	Quarterly ²	--
pH	standard units	Grab	Quarterly ²	Part 136 ³
Nitrate Nitrogen, Total (as N)	mg/L	Grab	Quarterly ²	Part 136 ³
Total Dissolved Solids (TDS)	mg/L	Grab	Quarterly ²	Part 136 ³
Sodium	mg/L	Grab	Quarterly ²	Part 136 ³

Parameter	Units	Sample Type	Minimum Sampling Frequency ¹	Required Analytical Test Method
Chloride	mg/L	Grab	Quarterly ²	Part 136 ³
Aluminum, Total Dissolved	mg/L	Grab	Quarterly ²	Part 136 ³

Table Notes:

1. The groundwater monitoring frequency may be increased or decreased based on the results of monitoring conducted during this permit term.
2. Quarterly monitoring shall occur during the months of February, May, August, and November.
3. Pollutants shall be analyzed using the analytical methods described in 40 C.F.R. part 136 or by methods approved by the Regional Water Board or State Water Board, such as with the current edition of *Standard Methods for Examination of Water and Wastewater* (American Public Health Administration).

9. OTHER MONITORING REQUIREMENTS

9.1. Filtration Process Monitoring

Filtration process monitoring shall demonstrate compliance with section 4.4.1 (Filtration Process Requirements) of the Order and applies to all treated wastewater flows. The following filtration process monitoring shall be implemented:

9.1.1. Effluent Filter Monitoring (Monitoring Location INT-001A)

9.1.1.1. **Monitoring.** The Permittee shall calculate, on a daily basis, the surface loading rate in gallons per minute per square foot and report the maximum surface loading rate and any exceedances of the surface loading rate limitations specified in section 4.4.1.1 of the Order. The rate of flow through the tertiary wastewater treatment process filters shall be measured at Monitoring Location INT-001A.

9.1.1.2. **Compliance.** Compliance with the maximum daily filter surface loading rate, as specified in section 60301.320 of the CCR Water Recycling Criteria (title 22), shall be calculated based on the flow rate through each filter unit.

9.1.1.3. **Reporting.** The daily instantaneous maximum filter surface loading rate, daily maximum tertiary filter flow rate, and daily average tertiary filter flow rate shall be reported on the monthly SMR's.

9.1.2. **Secondary Effluent/Filter Influent Turbidity Monitoring (Monitoring Location INT-001A)**

9.1.2.1. **Monitoring.** The turbidity of the filter influent shall be continuously measured and recorded. Should the turbidity meter and recorder fail, grab sampling at a minimum frequency of 4 hours may be substituted for a period of up to 24 hours. The recorded data shall be maintained by the Permittee for at least 3 years. The daily maximum turbidity results shall be reported for monitoring location INT-001A on the monthly SMRs.

9.1.2.2. **Compliance.** Compliance with the filter influent turbidity limitations specified in section 4.4.1.2 of the Order, shall be determined using the levels of recorded turbidity taken at intervals of no more than 15 minutes over a 24-hour period. Exceedances of these turbidity limits shall be mitigated by diverting all inadequately treated wastewater to temporary storage or an upstream process or automatically activated chemical addition to comply with title 22 requirements (sections 60304 and 60307).

9.1.2.3. **Reporting.**

9.1.2.3.1. The daily maximum values of filter influent turbidity shall be reported on the monthly SMRs.

9.1.2.3.2. If the filter influent turbidity exceeds 5 NTU for more than 15 minutes, or 10 NTU at any time, the incident shall be reported in the monthly SMR and to the Regional Water Board and the Division of Drinking Water (DDW) by telephone within 24 hours in accordance with Provision 6.1.2.2 of the Order. A written report describing the incident and the actions undertaken in response shall be included in the monthly SMR.

9.1.3. **Effluent Filter Monitoring (Monitoring Location INT-001B)**

9.1.3.1. **Monitoring.** The turbidity of the filter effluent shall be continuously measured and recorded. Should the turbidity meter and recorder fail, grab sampling at a minimum frequency of 1.2 hours may be substituted for a period of up to 24 hours. The recorded data shall be maintained by the Permittee for at least 3 years. The daily maximum, daily average, and 95th percentile turbidity results shall be reported for monitoring location INT-001B on the monthly SMRs.

9.1.3.2. **Compliance.** Compliance with the 95th percentile effluent turbidity limitation specified in title 22, as referenced in section 4.4.1.3 of the Order, shall be determined using the levels of recorded turbidity taken at intervals of no more than 1.2 hours over a 24-hour period. Exceedances of the maximum turbidity requirement referenced in section 4.4.1.3 of this Order shall not be considered

a violation of these waste discharge requirements if such exceedance does not exceed a duration of one minute.

Mitigation of the event shall consist of diverting all inadequately treated wastewater to temporary storage or an upstream process or automatically activated chemical addition to comply with title 22 requirements (sections 60304 and 60307).

9.1.3.3. **Reporting.**

- 9.1.3.3.1. The daily average, maximum, and 95th percentile values of combined effluent turbidity shall be reported on the monthly SMRs.
- 9.1.3.3.2. If the filtered effluent turbidity exceeds 2 NTU, based on a daily average, 5 NTU for more than 15 minutes, or 10 NTU at any time, the incident shall be reported in the monthly SMR and to the Regional Water Board and the Division of Drinking Water (DDW) by telephone within 24 hours in accordance with Provision 6.1.2.2 of the Order. A written report describing the incident and the actions undertaken in response shall be included in the monthly SMR.
- 9.1.3.3.3. A summary of compliance with all effluent filter requirements shall be included as part of the Permittee's Annual Recycled Water Report submitted to the Regional Water Board.

9.2. **Disinfection Process Monitoring for UV Disinfection System (Monitoring Location INT 002)**

9.2.1. **Monitoring Location INT-002**

- 9.2.1.1. **Monitoring.** The UV transmittance of the effluent from the UV disinfection system shall be monitored continuously and recorded at Monitoring Location INT-002. The operational UV dose shall be calculated from UV transmittance and flow.
- 9.2.1.2. **Compliance.** The UV transmittance shall not fall below 55 percent of maximum at any time, unless otherwise approved by DDW. The operational UV dose shall not fall below 100 millijoules per square centimeter (mJ/cm²) at any time, unless otherwise approved by DDW. Any inadequately treated and disinfected wastewater shall be diverted to a storage basin or an upstream process for adequate treatment. Flow through the UV disinfection system shall not exceed 3.7 mgd, unless otherwise approved by DDW.
- 9.2.1.3. **Reporting.** The Permittee shall report daily average and lowest daily transmittance and operational UV dose on its monthly SMRs. The Permittee

shall report daily average and maximum flow through the UV disinfection system. If the UV transmittance falls below 55 percent or UV dose falls below 100 mJ/cm², the event shall be reported to the Regional Water Board by telephone within 24 hours.

9.3. Visual Monitoring (Monitoring Locations EFF-002, RSW-001, RSW-003, and RSW-004)

9.3.1. Visual observations of the discharge (Monitoring Location EFF-002) and the receiving water (Monitoring Locations RSW-001, RSW-003, and RSW-004) shall be recorded monthly during periods of discharge to the Russian River. Visual monitoring shall include, but not be limited to, observations for floating materials, coloration, objectionable aquatic growths, oil and grease films, and odors. Visual observations shall be recorded and included in the Permittee's monthly SMRs.

9.4. Sludge Monitoring (Monitoring Location BIO-001)

9.4.1. Sludge sampling shall be conducted according to the requirements specified by the location and type of disposal activities undertaken.

9.4.2. Sampling records shall be retained for a minimum of 5 years. A log shall be maintained for sludge quantities generated and of handling and disposal activities. The frequency of entries is discretionary; however, the log must be complete enough to serve as a basis for developing the Sludge Handling and Disposal report that is required as part of the Annual Report.

10. REPORTING REQUIREMENTS

10.1. General Monitoring and Reporting Requirements

10.1.1. The Permittee shall comply with all Standard Provisions (Attachment D) related to monitoring, reporting, and recordkeeping.

10.2. Self-Monitoring Reports (SMRs)

10.2.1. The Permittee shall submit electronic Self-Monitoring Reports (eSMRs) using the State Water Board's [California Integrated Water Quality System](http://www.waterboards.ca.gov/water_issues/programs/ciwqs/) (CIWQS) Program website (http://www.waterboards.ca.gov/water_issues/programs/ciwqs/). The CIWQS website will provide additional information for SMR submittal in the event there will be a planned service interruption for electronic submittal. The Permittee shall maintain sufficient staffing and resources to ensure it submits eSMRs that are complete and timely. This includes provisions of training and supervision of

individuals (e.g., Permittee personnel or consultant) on how to prepare and submit eSMRs.

- 10.2.2. The Permittee shall report in the SMR the results for all monitoring specified in this MRP under sections 3 through 9. The Permittee shall submit monthly SMRs including the results of all required monitoring using U.S. EPA-approved test methods or other test methods specified in this Order. SMRs are to include all new monitoring results obtained since the last SMR was submitted.
- 10.2.3. If the Permittee monitors any pollutant more frequently than required by this Order, the results of this monitoring shall be included in the calculations and reporting of the data submitted in the SMR.
- 10.2.4. All monitoring results reported shall be supported by the inclusion of the complete analytical report from the laboratory that conducted the analyses.
- 10.2.5. Monitoring periods and reporting for all required monitoring shall be completed according to the following schedule:

Table E-12. Monitoring Periods and Reporting Schedule

Sampling Frequency	Monitoring Period Begins On...	Monitoring Period	SMR Due Date
Continuous	Permit effective date	(Midnight through 11:59 PM) or any 24-hour period that reasonably represents a calendar day for purposes of sampling.	First day of second calendar month following the end of each month
Daily	Permit effective date	(Midnight through 11:59 PM) or any 24-hour period that reasonably represents a calendar day for purposes of sampling	First day of second calendar month following the end of each month

Sampling Frequency	Monitoring Period Begins On...	Monitoring Period	SMR Due Date
Weekly	Sunday following permit effective date or on permit effective date if on a Sunday	Sunday through Saturday	First day of second calendar month following the end of each month
Monthly	First day of calendar month following permit effective date or on permit effective date if that date is first day of the month	First day of calendar month through last day of calendar month	First day of second calendar month following the end of each month
Quarterly ¹	January 1, April 1, July 1, October 1	First day of calendar quarter through last day of calendar quarter	First day of second calendar month following the end of each quarter
Semiannually	Closest of January 1 or July 1 following (or on) permit effective date	January 1 through June 30 and July 1 through December 31	September 1, each year and March 1, each year
Annually ²	January 1 following (or on) permit effective date	January 1 through December 31	March 1, each year (with annual report)
4 Samples (1/Year)	October 1 following (or on) permit effective date	October 1 through November 30	March 1, each year (with annual report)
Twice per year	August 1 following (or on) permit effective date	May 1 through 31 and August 1 through 31	July 1 and October 1 each year (with May and August SMRs)
Once per permit term	Permit effective date	All	As stated in MRP tables or by March 1, 2025

Sampling Frequency	Monitoring Period Begins On...	Monitoring Period	SMR Due Date
--------------------	--------------------------------	-------------------	--------------

Table Notes:

1. Quarterly monitoring periods are as follows: January 1 through March 31; April 1 through June 30; July 1 through September 30; and October 1 through December 31.
2. Annual samples required for discharge to receiving water (Discharge Points 002 and 005) shall be taken once per discharge season.

10.2.6. **Reporting Protocols.** The Permittee shall report with each sample result the applicable reported Minimum Level (reported ML, also known as the Reporting Level, or RL) and the current Method Detection Limit (MDL), as determined by the procedure in 40 C.F.R. part 136.

The Permittee shall report the results of analytical determinations for the presence of chemical constituents in a sample using the following reporting protocols:

10.2.6.1. Sample results greater than or equal to the reported ML shall be reported as measured by the laboratory (i.e., the measured chemical concentration in the sample).

10.2.6.2. Sample results less than the reported ML, but greater than or equal to the laboratory's MDL, shall be reported as "Detected, but Not Quantified," or DNQ. The estimated chemical concentration of the sample shall also be reported.

For the purposes of data collection, the laboratory shall write the estimated chemical concentration next to DNQ as well as the words "Estimated Concentration" (may be shortened to "Est. Conc."). The laboratory may, if such information is available, include numerical estimates of the data quality for the reported result. Numerical estimates of data quality may be percent accuracy (\pm a percentage of the reported value), numerical ranges (low to high), or any other means considered appropriate by the laboratory.

10.2.6.3. Sample results less than the laboratory's MDL shall be reported as "Not Detected," or ND.

10.2.6.4. The Permittee is to instruct laboratories to establish calibration standards so that the ML value (or its equivalent if there is differential treatment of samples relative to calibration standards) is the lowest calibration standard. At no time is the Permittee to use analytical data derived from extrapolation beyond the lowest point of the calibration curve.

10.2.7. The Permittee shall submit SMRs in accordance with the following requirements:

10.2.7.1. The Permittee shall arrange all reported data in a tabular format. The data shall be summarized to clearly illustrate whether the facility is operating in compliance with interim and/or final effluent limitations. The Permittee is not required to duplicate the submittal of data that is entered in a tabular format within CIWQS. When electronic submittal of data is required and CIWQS does not provide for entry into a tabular format within the system, the Permittee shall electronically submit the data in a tabular format as an attachment.

10.2.7.2. The Permittee shall attach a cover letter to the SMR. The information contained in the cover letter shall clearly identify:

10.2.7.2.1. Facility name and address;

10.2.7.2.2. WDID number;

10.2.7.2.3. Applicable period of monitoring and reporting;

10.2.7.2.4. Violations of the WDRs (identified violations must include a description of the requirement that was violated and a description of the violation);

10.2.7.2.5. Corrective actions taken or planned; and

10.2.7.2.6. The proposed time schedule for corrective actions.

10.2.7.3. SMRs must be submitted to the Regional Water Board, signed and certified as required by the Standard Provisions (Attachment D), to the [CIWQS Program Web site](http://www.waterboards.ca.gov/ciwqs/index.html) (<http://www.waterboards.ca.gov/ciwqs/index.html>).

In the event that an alternate method for submittal of SMRs is required, the Permittee shall submit the SMR electronically via e-mail to NorthCoast@waterboards.ca.gov or on disk (CD or DVD) in Portable Document Format (PDF) file in lieu of paper-sourced documents. The guidelines for electronic submittal of documents can be found on the [Regional Water Board website](http://waterboards.ca.gov/northcoast) (<http://waterboards.ca.gov/northcoast>).

10.2.7.4. At any time during the term of this permit, the Regional Water Board may notify the Permittee to electronically submit both technical and Self-Monitoring Reports (SMRs) to the State Water Board's GeoTracker database in searchable Portable Document Format (pdf). In addition, analytical data will be required to be uploaded to the GeoTracker database under a site-specific global identification number that will be assigned to the Permittee. Information on the GeoTracker database is provided on the State Water Board website at: https://www.waterboards.ca.gov/resources/data_databases/groundwater.shtml

10.3. Discharge Monitoring Reports (DMRs)

10.3.1. DMRs are U.S. EPA reporting requirements. The Permittee shall electronically certify and submit DMRs together with SMRs using Electronic Self-Monitoring Reports module eSMR 2.5 or any upgraded version. DMRs shall be submitted monthly on the first day of the second calendar month following the end of each monthly sampling period. Electronic DMR submittal shall be in addition to electronic SMR submittal. Information about electronic DMR submittal is available at the [DMR website](http://www.waterboards.ca.gov/water_issues/programs/discharge_monitoring):
(http://www.waterboards.ca.gov/water_issues/programs/discharge_monitoring).

10.4. Other Reports

10.4.1. **Special Study Reports and Progress Reports.** Special study and progress reports shall be submitted in accordance with the following reporting requirements.

Table E-13. Reporting Requirements for Special Provisions Reports

Order Section	Special Provision Requirement	Reporting Requirement
Special Provision 6.3.2.1.1	Land Discharge/Recycled Water /Operations and Management Plan preparation and submittal	May 1, 2022
Special Provision 6.3.2.1.2	Land Discharge/Recycled Water /Operations and Management Plan review, update and submit	As necessary
Special Provision 6.3.2.2	Pathogen Special Study Work Plan	July 1, 2022
Special Provision 6.3.2.2	Pathogen Special Study Final Report	August 1, 2025
Special Provision 6.3.2.3	Disaster Preparedness Assessment Report and Action Plan.	September 1, 2023
Special Provision 6.3.3.1.1	Pollutant Minimization Program	If required by the Regional Water Board Executive Officer
Special Provision 6.3.3.1.2.5	Pollutant Minimization Program, Annual Facility Report	March 1, annually , following development of Pollutant Minimization Program

Order Section	Special Provision Requirement	Reporting Requirement
Special Provision 6.3.4.2	Operations and Maintenance Manual	Update as necessary
Special Provision 6.3.5.2.1	Source Control and Pretreatment Provisions, Annual Report	March 1, annually
Special Provision 6.3.5.2.2.1	Source Control and Pretreatment Provisions, Notification of Discharges that Trigger Pretreatment Requirements	Within 30 days of discharges that trigger pretreatment requirements
Special Provision 6.3.5.2.2.2	Source Control and Pretreatment Provisions, Revised Report of Waste Discharge and Pretreatment Program	Within 1 year of discharges that trigger pretreatment requirements
Special Provision 6.3.5.6	Adequate Capacity, Technical Report	Within 120 days of notification that the Facility will reach capacity within 4 years
Special Provision 6.3.6.2.1	Flood Control/Flow Reduction Mitigation Summary Report	November 1, 2021
Special Provision 6.3.6.2.2	Sewer Evaluation and Capacity Assurance Plan (SECAP)/Engineering Study Work Plan	February 1, 2023
Special Provision 6.3.6.2.2.1	Submit Revised SECAP Report	August 1, 2024
Special Provision 6.3.6.2.2.3	Submit Engineering Study Report	August 1, 2025
MRP General Monitoring Provision 1.6	DMR-QA Study Report	Annually , per State Water Board instructions
MRP Whole Effluent Testing Requirements 5.1.5.3 and 5.2.5.2	Species Sensitivity Screening	March 31, 2025

Order Section	Special Provision Requirement	Reporting Requirement
MRP Effluent Monitoring Requirements 5.1.8 and 5.2.8	Verbal and written notification of acute or chronic toxicity fail result	Within 72 hours (verbal) and 14 days (written) after receipt of a fail result.
MRP Effluent Monitoring Requirement 5.1.10.4	Notification of TRE/TIE Results	No later than 30 days from the completion of each aspect of the TRE/TIE analyses.
MRP Effluent Monitoring Requirement 5.2.10.2	TRE/TIE Results	Within 60 days of completion of TRE/TIE analyses
MRP Effluent Monitoring Requirement 5.3.1	TRE Work Plan review	December 1, 2021
MRP Effluent Monitoring Requirement 5.3.1	TRE Work Plan notification and submit revised TRE Work Plan as necessary	March 1, 2022
MRP Effluent Monitoring Requirement 5.3.2	Detailed TRE Work Plan	Within 30 days of an accelerated monitoring test that results in "Fail"
MRP Reporting Requirement 10.4.2	Annual Report	March 1 , annually
MRP Reporting Requirement 10.4.3	Annual Volumetric Reporting to Geotracker	April 30 , annually
MRP Reporting Requirement 10.4.4	Water Recycling System Annual Report	April 30 , annually
MRP Reporting Requirement 10.5.1	Notification of spills and unauthorized discharges.	Oral reporting within 24 hours and written report within 5 days
MRP Reporting Requirement 10.5.2	Public Spill Notification Plan	August 1, 2022
MRP Reporting Requirement 10.5.4.1.1	Notification of tertiary recycled water spills greater than or equal to 50,000 gallons	Notification as soon as becoming aware of the discharge and notification is possible

Order Section	Special Provision Requirement	Reporting Requirement
MRP Reporting Requirement 10.5.4.1.2	Notification of tertiary recycled water spills greater than 1,000 gallons and less than 50,000 gallons	Notification as soon as possible, but no longer than 3 days after becoming aware of the discharge
MRP Reporting Requirement 10.5.4.2	Notification of Delivery of Inadequately Treated Recycled Water	Notification immediately by telephone

10.4.2. **Annual Report.** The Permittee shall submit an annual report to the Regional Water Board for each calendar year through the CIWQS Program Web site. In the event that a paper copy of the annual report is required, the Permittee shall submit the report to the email address in section 10.2.6.3, above. The report shall be submitted by **March 1st** of the following year. The report shall, at a minimum, include the following:

- 10.4.2.1. Where appropriate, tabular and/or graphical summaries of the monitoring data and disposal records from the previous year. If the Permittee monitors any pollutant more frequently than required by this Order, using test procedures approved under 40 C.F.R. part 136 or as specified in this Order, the results of this monitoring shall be included in the calculation and report of the data submitted in the SMR.
- 10.4.2.2. A comprehensive discussion of the Facility’s compliance (or lack thereof) with all effluent limitations and other WDRs, and the corrective actions taken or planned, which may be needed to bring the discharge into full compliance with the Order.
- 10.4.2.3. The names and general responsibilities of all persons employed at the Facility;
- 10.4.2.4. The names and telephone numbers of persons to contact regarding the Facility for emergency and routine situations; and
- 10.4.2.5. A statement certifying when the flow meter(s) and other monitoring instruments and devices were last calibrated, including identification of who performed the calibration.
- 10.4.2.6. **Source Control Activity Reporting.** The Permittee shall submit, as part of its Annual Report to the Regional Water Board, a description of the Permittee’s source control activities, as required by Special Provision 6.3.5.2, during the past year. This annual report is due on March 1st of each year, and shall contain:

- 10.4.2.6.1. A copy of the source control standards, including a table presenting local limits.
- 10.4.2.6.2. A description of the waste hauler permit system; if applicable.
- 10.4.2.6.3. A summary of the compliance and enforcement activities taken by the Permittee during the past year, which ensures industrial user compliance. The summary shall include the names and addresses of any industrial or commercial users under surveillance by the Permittee, an explanation of whether they were inspected, sampled, or both, the frequency of these activities at each user, and the conclusions or results from the inspection or sampling of each user.
- 10.4.2.6.4. An updated list of industrial users (by North American Industrial Classification/Standard Industrial Classification categories) which were issued permits and/or enforcement orders, and a status of compliance for each user.
- 10.4.2.6.5. The name and address of each user that received a discharge limit.
- 10.4.2.6.6. A summary of any industrial waste survey results.
- 10.4.2.6.7. A summary of public outreach activities to educate industrial, commercial, and residential users about the importance of preventing discharges of industrial and toxic wastes to the Facility.
- 10.4.2.7. **Sludge Handling and Disposal Activity Reporting.** The Permittee shall submit, as part of its annual report to the Regional Water Board, a description of the Permittee's solids handling, disposal and reuse activities over the previous 12 months. At a minimum, the report shall contain:
 - 10.4.2.7.1. Annual sludge production, in dry tons and percent solids;
 - 10.4.2.7.2. Sludge monitoring results;
 - 10.4.2.7.3. A schematic diagram showing sludge handling facilities (e.g., digesters, thickeners, drying beds, etc.), if any and a solids flow diagram;
 - 10.4.2.7.4. Methods of final disposal of sludge:
 - 10.4.2.7.4.1. For any portion of sludge discharged to a sanitary landfill, the Permittee shall provide the volume of sludge transported to the landfill, the names and locations of the facilities receiving sludge, the Regional Water Board's WDRs Order number for the regulated landfill, and the landfill classification.

- 10.4.2.7.4.2. For any portion of sludge discharged through land application, the Permittee shall provide the volume of biosolids applied, the date and locations where biosolids were applied, the Regional Water Board's WDRs Order number for the regulated discharge, a demonstration that the discharge was conducted in compliance with applicable permits and regulations, and, if applicable, corrective actions taken or planned to bring the discharge into compliance with WDRs.
- 10.4.2.7.4.3. For any portion of sludge further treated through composting, the Permittee shall provide a summary of the composting process, the volume of sludge composted, and a demonstration and signed certification statement that the composting process and final product met all requirements for Class A biosolids.
- 10.4.2.7.5. Results of internal or external third-party audits of the Biosolids Management System, including reported program deficiencies and recommendations, required corrective actions, and a schedule to complete corrective actions.
- 10.4.2.8. **Storm Water Reporting.** The Permittee shall submit, as part of its annual report to the Regional Water Board, an evaluation of the effectiveness of the Permittee's best management practices (BMPs) to control the run-on of storm water to the Facility site, as well as activities to maintain and upgrade these BMPs.
- 10.4.2.9. **Flood Control and Flow Reduction Mitigation Reporting.** The Permittee shall submit, as part of its annual report to the Regional Water Board, a summary of all flood control and flow reduction mitigation measures that the Permittee implemented in the prior year and provide an evaluation of the effectiveness of those flood control and flow reduction mitigation measures and recommendations for improving the flood control and flow reduction mitigation program for the upcoming year.
- 10.4.2.10. **Sanitary Sewer System Reporting.** The Permittee shall submit as part of the annual report to the Regional Water Board, a description of the Permittee's activities to correct deficiencies and reduce inflow and infiltration (I&I) into the collection system. The report shall include, but not be limited to the following:
- 10.4.2.10.1. A description of any assessment work to characterize the collection system and identify deficiencies;
- 10.4.2.10.2. A description of replacement and rehabilitation of the collection system, including details about replaced/rehabilitated infrastructure, including pipeline, manholes, lift stations, etc.

10.4.2.10.3. A description of any changes in the Permittee's ordinances and programs to address I&I.

10.4.2.10.4. The financial resources spent on collection system assessment, rehabilitation, and repair work during the calendar year, and the amount of financial resources budgeted for the upcoming calendar year.

10.4.2.11. **Land Discharge Report.** The Permittee shall submit a Land Discharge Report, as part of its annual report to the Regional Water Board. The Report shall, at a minimum include:

10.4.2.11.1. A summary of all land disposal area inspections conducted by the Permittee and summary of all violations of Land Discharge Requirements in Order section 4.2.2.

10.4.2.11.2. Certification that all reasonable BMPs and management practices were implemented to ensure efficient and compliant operation of the land disposal system;

10.4.2.11.3. A discussion of the performance of the land disposal system, including discussion of capacity issues, system problems, and other identified deficiencies.

10.4.2.11.4. A corrective action plan and schedule for correcting any capacity issues, system problems, or other identified deficiencies.

10.4.3. **Annual Volumetric Reporting.** The Permittee shall electronically certify and submit an annual volumetric report, containing monthly data in electronic format, to State Water Board's [GeoTracker system](https://geotracker.waterboards.ca.gov/) (<https://geotracker.waterboards.ca.gov/>) by April 30 of the following year. Required data shall be submitted to the GeoTracker database under a site-specific global identification number. The Permittee shall report in accordance with each of the items in Section 3 of the Recycled Water Policy as described below:

10.4.3.1. **Influent.** Monthly volume of wastewater collected and treated by the Facility.

10.4.3.2. **Production.** Monthly volume of wastewater treated, specifying level of treatment.

10.4.3.3. **Discharge.** Monthly volume of treated wastewater discharged to each of the following, specifying level of treatment:

10.4.3.3.1. Inland surface waters, specifying volume required to maintain minimum instream flow, if any; and

10.4.3.3.2. Land, where beneficial use is not taking place, including evaporation or percolation ponds, overland flow, or spray irrigation disposal, excluding pasture or fields with harvested crops.

10.4.3.4. **Reuse.**

10.4.3.4.1. Monthly Volume of treated wastewater distributed.

10.4.3.4.2. Annual volume of treated wastewater distributed for beneficial use in compliance with California Code of Regulations, title 22 in each of the use categories listed below:

10.4.3.4.2.1. Agricultural irrigation: pasture or crop irrigation.

10.4.3.4.2.2. Landscape irrigation: irrigation of parks, greenbelts, and playgrounds; school yards; athletic fields; cemeteries; residential landscaping, common areas; commercial landscaping; industrial landscaping; and freeway, highway, and street landscaping.

10.4.3.4.2.3. Golf course irrigation: irrigation of golf courses, including water used to maintain aesthetic impoundments within golf courses.

10.4.3.4.2.4. Commercial application: commercial facilities, business use (such as laundries and office buildings), car washes, retail nurseries, and appurtenant landscaping that is not separately metered.

10.4.3.4.2.5. Industrial application: manufacturing facilities, cooling towers, process water, and appurtenant landscaping that is not separately metered.

10.4.3.4.2.6. Geothermal energy production: augmentation of geothermal fields.

10.4.3.4.2.7. Other non-potable uses: including but not limited to dust control, flushing sewers, fire protection, fill stations, snow making, and recreational impoundments.

10.4.4. **Water Recycling System Annual Report**

The Permittee shall submit a Water Recycling System annual report to the Regional Water Board for each calendar year through the CIWQS Program Web site. In the event that an alternate method for submittal of the annual report is required, the Permittee shall submit the report electronically to the email address in section 10.2.4.3., above. The report shall be submitted by April 30th of the following year. The report shall, at a minimum, include the following:

10.4.4.1. A summary table of all recycled water users and use areas, including the following information:

- 10.4.4.1.1. Use site names;
- 10.4.4.1.2. Locations of recycled water use sites, including a map. Newly permitted recycled water users and use areas shall be clearly identified and, when applicable, supplement to the title 22 Engineering Report and the State Water Board Division of Drinking Water approval letter supporting those additions shall be included;
- 10.4.4.1.3. Name and contact information for the recycled water operator responsible for the operation, maintenance, and system monitoring;
- 10.4.4.1.4. Use site acreage; and
- 10.4.4.1.5. Total volume of recycled water supplied to each recycled water use site for each month of the reporting period.
- 10.4.4.2. A summary of recycled water use site inspections conducted by the Permittee or recycled water users and identification of recycled water user violations, including:
 - 10.4.4.2.1. Inspection Dates;
 - 10.4.4.2.2. All observations of over-application (e.g., ponding, excessive saturation, etc.) and/or runoff;
 - 10.4.4.2.3. Misuses of recycled water;
 - 10.4.4.2.4. The number and location of any cross-connections and/or improper backflow prevention devices; and
 - 10.4.4.2.5. Any other violations of the Master Recycling Permit or the Permittee's rules and regulations.
 - 10.4.4.2.6. If violations occurred, the report shall also discuss the corrective actions taken and planned to bring the recycled water program into full compliance with this Order.
- 10.4.4.3. An evaluation of the performance of the recycled water treatment facility, including discussion of capacity issues, system problems, and a forecast of the flows anticipated in the next year.
- 10.4.4.4. An evaluation verifying that the application of recycled water to each use area occurred at reasonable agronomic rates utilizing the data required by Table E-7 of the MRP. If the agronomic rate evaluation determines that exceedances of the agronomic rate may be occurring, the Permittee shall identify and

implement corrective actions to ensure recycled water use occurs at reasonable agronomic rates.

- 10.4.4.5. Certification that all reasonable BMPs and management practices were implemented to ensure efficient and compliant operation of the recycled water system.
- 10.4.4.6. Identification of any other problems that occurred in the recycled water system during the prior year and plans to rectify those problems in the coming year.
- 10.4.4.7. A summary of all enforcement activities initiated by the Permittee, including a discussion of corrective action taken, as well as any planned or proposed actions needed to bring the use of recycled water into compliance with the requirements of this Order. Copies of documentation of any enforcement actions taken by the Permittee shall be provided.
- 10.4.4.8. A summary of operational problems, plant equipment malfunctions, and any diversion of recycled water which does not meet the requirements specified in this Order.
- 10.4.4.9. Documentation of notifications to users if any recycled water was delivered that did not meet the requirements specified in this Order.
- 10.4.4.10. A record of equipment or process failures initiating an alarm, as well as any corrective and preventative actions.
- 10.4.4.11. A summary of scheduled and non-scheduled maintenance of the recycled water system appurtenances and irrigation areas.
- 10.4.4.12. Enforcement and monitoring activities that occurred during the previous year, and identification of any problems and how the problems were addressed.
- 10.4.4.13. If applicable, a summary of all cross-connection testing and back-flow prevention activities (inspections, maintenance) and a summary of any problems identified, or certification that no problems occurred.
- 10.4.4.14. The name and contact information for the recycled water operator responsible for operation, maintenance, and system monitoring.
- 10.4.4.15. A transmittal letter shall accompany each annual report. The letter shall summarize the numbers and severity of violations found during the reporting period, and actions taken or planned to correct the violations and prevent future violations. The transmittal letter shall contain the following penalty of perjury statement and shall be signed by the Permittee's authorized agent:

“I certify under penalty of law that I have personally examined and am familiar with the information submitted in this document and all attachments and that, based on my inquiry of those individuals immediately responsible for obtaining the information, I believe that the information is true, accurate, and complete. I am aware that there are significant penalties for submitting false information, including the possibility of fine and imprisonment.”

10.5. Spill Notification

10.5.1. **Spills and Unauthorized Discharges.** Information regarding all spills and unauthorized discharges (except SSOs) that may endanger health or the environment shall be provided orally to the Regional Water Board⁵ within 24 hours from the time the Permittee becomes aware of the circumstances and a written report shall also be provided within five (5) days of the time the Permittee becomes aware of the circumstances, in accordance with section 5.5 of Attachment D.

Information to be provided verbally to the Regional Water Board includes:

- 10.5.1.1. Name and contact information of caller;
- 10.5.1.2. Date, time, and location of spill or unauthorized discharge occurrence;
- 10.5.1.3. Estimates of spill or unauthorized spill volume, rate of flow, and spill duration, if available and reasonably accurate;
- 10.5.1.4. Surface water bodies impacted, if any;
- 10.5.1.5. Cause of spill or unauthorized discharge, if known at the time of the notification;
- 10.5.1.6. Cleanup actions taken or repairs made at the time of the notification;

⁵ The contact number of the Regional Water Board during normal business hours is (707) 576-2220. After normal business hours, spill reporting to the California Governor’s Office of Emergency Services Warning Center (CalOES) will satisfy the 24-hour spill reporting requirement for the Regional Water Board. The contact number for spill reporting for the CalOES is (800) 852-7550.

10.5.1.7. Status of public notifications made to alert the local community and downstream users impacted by the spill or unauthorized discharge; and

10.5.1.8. Responding agencies.

10.5.2. **Public Spill Notification Plan.** By **August 1, 2022**, the Permittee shall submit a public spill notification plan to the Regional Water Board for Executive Officer approval, describing the Permittee's plans and procedures for timely notification of community members that are or may be impacted by spills and unauthorized discharges that may occur within the collection system or from the treatment plant. The public spill notification plan must demonstrate that adequate plans and procedures are in place to ensure that the immediate community members (i.e., residents in the immediate area of the spill) and any downstream community members that may be affected by spills into neighborhoods and that reach surface waters are properly notified. The public spill notification plan must demonstrate that methods of communication with the public are appropriate for the type and conditions of the spill. The Permittee shall engage with interested stakeholders to seek public input in the development of the Plan prior to submittal of the Plan and provide documentation of this public process in the Plan.

10.5.3. **Sanitary Sewer Overflows.** Notification and reporting of sanitary sewer overflows is conducted in accordance with the requirements of Order No. 2006-0003-DWQ (Statewide General WDRs for Sanitary Sewer Systems), which is not incorporated herein by reference, and any revisions thereto.

10.5.4. **Recycled Water Spills.** Notification and reporting of spills and unauthorized discharges of recycled water discharged in or on any waters of the State, as defined in Water Code section 13050, shall be conducted in accordance with the following:

10.5.4.1. **Tertiary Recycled Water**

10.5.4.1.1. For unauthorized discharges of 50,000 gallons or more of tertiary recycled water, the Permittee shall immediately notify the Regional Water Board as soon as (a) the Permittee has knowledge of the discharge or probable discharge, (b) notification is possible, and (c) notification can be provided without substantially impeding cleanup or other emergency measures.

- 10.5.4.1.2. For unauthorized discharges of more than 1,000 gallons, but less than 50,000 gallons of tertiary recycled water, the Permittee shall notify the Regional Water Board as soon as possible, but no longer than three days after becoming aware of the discharge.
- 10.5.4.2. **Delivery of Inadequately Treated Recycled Water.** Any discharge of untreated or partially treated wastewater to any recycled water use area shall be reported immediately by telephone to the North Coast Regional Water Board, State Water Board DDW-Sonoma District office, and the local health officer.

ATTACHMENT F - FACT SHEET

TABLE OF CONTENTS

1.	Permit Information.....	F-3
2.	Facility Description.....	F-5
2.1.	Description of Wastewater and Biosolids Treatment and Controls.....	F-5
2.2.	Discharge Points and Receiving Waters.....	F-8
2.3.	Summary of Existing Requirements and SMR Data.....	F-9
2.4.	Compliance Summary.....	F-13
2.5.	Recent and Planned Changes.....	F-14
3.	Applicable Plans, Policies, and Regulations.....	F-14
3.1.	Legal Authorities.....	F-14
3.2.	California Environmental Quality Act (CEQA).....	F-15
3.3.	State and Federal Laws, Regulations, Policies, and Plans.....	F-16
3.4.	Impaired Water Bodies on the CWA section 303(d) List.....	F-20
3.5.	Other Plans, Policies and Regulations.....	F-22
4.	Rationale for Effluent Limitations and Discharge Specifications.....	F-24
4.1.	Discharge Prohibitions.....	F-24
4.2.	Technology-Based Effluent Limitations.....	F-28
4.3.	Water Quality-Based Effluent Limitations (WQBELs).....	F-31
4.4.	Final Effluent Limitation Considerations.....	F-51
4.5.	Interim Effluent Limitations – Not Applicable.....	F-54
4.6.	Land Discharge Specifications.....	F-54
4.7.	Water Recycling Specifications and Requirements.....	F-56
4.8.	Other Requirements.....	F-59
5.	Rationale for Receiving Water Limitations.....	F-61
5.1.	Surface Water.....	F-61
5.2.	Groundwater.....	F-61
6.	Rationale for Provisions.....	F-63
6.1.	Standard Provisions.....	F-63
6.2.	Monitoring and Reporting Program (MRP) Requirements.....	F-63
6.3.	Special Provisions.....	F-64
7.	Rationale for Monitoring and Reporting Requirements.....	F-72
7.1.	Influent Monitoring.....	F-72
7.2.	Effluent Monitoring.....	F-72
7.3.	Whole Effluent Toxicity Testing Requirements.....	F-74

7.4. Land Discharge Monitoring Requirements (LND-001).....	F-75
7.5. Recycled Water Monitoring Requirements (REC-001)	F-75
7.6. Receiving Water Monitoring.....	F-76
7.7. Other Monitoring Requirements.....	F-78
8. Public Participation.....	F-80
8.1. Notification of Interested Parties.....	F-80
8.2. Written Comments	F-80
8.3. Public Hearing	F-81
8.4. Waste Discharge Requirements and Petitions	F-81
8.5. Information and Copying	F-82
8.6. Register of Interested Persons	F-82
8.7. Additional Information.....	F-82

TABLE OF TABLES

Table F-1. Facility Information.....	F-3
Table F-2. Historic Effluent Limitations and Monitoring Data at Discharge Point 001 (October 2014 – August 2020).....	F-10
Table F-3. Historic Effluent Limitations and Monitoring Data – Discharge Point 002.....	F-12
Table F-4. Basin Plan Beneficial Uses	F-17
Table F-5. Summary of Reasonable Potential Analysis Results for Priority Pollutants, Ammonia, and Title 22 Pollutants.....	F-40
Table F-6. Determination of Long-Term Averages	F-45
Table F-7. Summary of Chronic Toxicity Results (TUc)	F-47

ATTACHMENT F - FACT SHEET

As described in section 2.2 of this Order, the Regional Water Board incorporates this Fact Sheet as findings of the Regional Water Board supporting the issuance of this Order. This Fact Sheet includes the legal requirements and technical rationale that serve as the basis for the requirements of this Order.

This Order has been prepared under a standardized format to accommodate a broad range of discharge requirements for dischargers in California. Only those sections or subsections of this Order that are specifically identified as “not applicable” have been determined not to apply to this Permittee. Sections or subsections of this Order not specifically identified as “not applicable” are fully applicable to this Permittee.

1. PERMIT INFORMATION

The following table summarizes administrative information related to the facility.

Table F-1. Facility Information

WDID	1B82045OSON
Permittee	Russian River County Sanitation District and Sonoma Water
Name of Facility	Russian River Wastewater Treatment Facility
Facility Address	18400 Neeley Road Guerneville, CA 95446 Sonoma County
Facility Contact, Title and Phone	Bret Beaudreau, Water Agency Operations Coordinator, (707) 521-1848
Authorized Person to Sign and Submit Reports	Pam Jeane, Assistant General Manager or other Sonoma Water staff with proper signatory authority
Mailing Address	404 Aviation Boulevard Santa Rosa, CA 95403
Billing Address	404 Aviation Boulevard Santa Rosa, CA 95403
Type of Facility	Publicly Owned Treatment Works (POTW)
Major or Minor Facility	Minor
Threat to Water Quality	1

Complexity	A
Pretreatment Program	No
Recycling Requirements	Producer
Facility Permitted Flow	0.51 million gallons per day (mgd) (average daily dry weather flow)
Facility Design Flow	0.71 mgd (average dry weather treatment capacity) 3.5 mgd (peak wet weather treatment capacity)
Watershed	Russian River Hydrologic Unit
Receiving Water	Russian River
Receiving Water Type	Inland surface water

- 1.1. The Russian River County Sanitation District and Sonoma Water (hereinafter Permittee) are the owner and operator, respectively, of the Russian River Wastewater Treatment Facility (hereinafter Facility), a POTW.

For the purposes of this Order, references to the “discharger” or “permittee” in applicable federal and state laws, regulations, plans, or policy are held to be equivalent to references to the Permittee herein.

The Permittee is authorized to discharge subject to waste discharge requirements (WDRs) in this Order at the discharge locations described in Table 1 on the cover page of this Order. The Code of Federal Regulations at 40 C.F.R. section 122.46 limits the duration of National Pollutant Discharge Elimination System (NPDES) permits to be effective for a fixed term not to exceed five years. Accordingly, this Order limits the effective period for the discharge authorized by this Order (see Order page 2). Pursuant to California Code of Regulations (CCR), title 23, section 2235.4, the terms and conditions of an expired permit are automatically continued pending issuance of a new permit if all requirements of the federal NPDES regulations on continuation of expired permits are complied with.

- 1.2. The Facility discharges tertiary treated wastewater to the Russian River, a water of the United States. The Permittee was previously regulated by Order No. R1-2014-0002 and NPDES Permit No. CA0024058 adopted on March 13, 2014 with an expiration date of April 30, 2019. Attachment B includes three maps including Figure B-1, a site map of the area around the Facility; Figure B-2, a layout of the Facility; and Figure B-3, a map of the recycled water use site (Northwood Golf Course) and irrigation (land disposal) locations in relation to the Facility. Attachment C provides a flow schematic of the Facility. Site visits were conducted on September 26, 2018 and November 19, 2020 to observe operations and

collect additional data to develop permit limitations and requirements for waste discharge.

- 1.3. The Permittee filed a report of waste discharge (ROWD) and submitted an application for reissuance of its WDRs and NPDES permit on October 30, 2018. The application was deemed complete on February 5, 2019. Due to heavy caseloads, preparation of this permit for adoption was delayed for more than two years, therefore Regional Water Board staff requested submittal of additional information to ensure that this Order is as current as possible. Supplemental information was submitted by the Permittee on September 25, 2020, October 26, 2020, and January 20, 2021.

2. FACILITY DESCRIPTION

The Permittee owns and operates municipal wastewater collection, treatment, disposal and recycled water facilities that provide service to a population of approximately 6,500 residential, commercial, industrial, recreational, institutional, and governmental customers within the greater Guerneville area, including unincorporated areas of Rio Nido, Vacation Beach, Guerneville, and Guerneville Park.

2.1. Description of Wastewater and Biosolids Treatment and Controls

2.1.1. Collection System

The wastewater collection system consists of approximately 35 miles of gravity sewer pipelines, 5 miles of force main, and 11 lift stations that convey wastewater to the Facility.

The collection system is subject to high infiltration and inflow (I&I), particularly during river flooding events. Significant sanitary sewer overflows occur during periods of high flows and flood conditions. During the term of the 2014 permit, significant sanitary sewer overflows (SSOs) occurred during flood conditions in 2017 and 2019 and are being addressed through a separate enforcement action. These overflows demonstrate that the collection system may have deficiencies and is unable to preclude all sources of I&I.

During the terms of the 2009 and 2014 permits, the Permittee implemented measures to address I&I in the collection system. In addition, the Permittee completed the Third Unit Process project in 2005 which increased treatment capacity from 1.2 mgd to 3.5 mgd.

The Permittee's current I&I program includes replacing and/or repairing deficiencies found during video inspections, smoke testing, and line cleaning, as well as education of residents and facilities that use temporary connections

(e.g., campgrounds, trailer parks) to shut off connection points during flood events. The Permittee received a grant from the State Water Board to implement a project to assess the condition of the headworks and aging lift stations, and to prioritize necessary rehabilitation and/or replacement of its aging infrastructure. The assessment work is expected to begin in late 2021 and to be completed sometime in 2022, followed by initial designs and environmental permitting for identified projects in 2023. The Permittee anticipates applying to the State Water Board in 2024 for construction grant funding to rehabilitate and/or replace aging infrastructure.

This Order requires the Permittee to continue to work on its I&I reduction program, conduct an engineering evaluation of the collection system and how it interacts with the treatment plant during flood conditions, and to develop a written plan that describes an implementation plan to notify the public when there are SSOs or unauthorized discharges from the collection system or the treatment plant.

Regional and State Water Board staff conducted an inspection of the collection system on December 6, 2019 and are working with the Permittee to develop a plan and funding to address deficiencies in order to reduce spills as further discussed in Fact Sheet section 6.3.6.2.

2.1.2. **Wastewater Treatment Facility**

The Facility is designed to treat an average dry weather flow of 0.71 mgd and a peak wet weather flow of 3.5 mgd of disinfected tertiary treated wastewater. The treatment system consists of coarse screening and aerated grit removal, aeration, biological nutrient removal (BNR), secondary clarification, tertiary filtration, and ultraviolet light (UV) disinfection.

The headworks consists of two screens with 0.25-inch mesh for solids removal, one Parshall flume for flow measurement, and an 8,560 gallon aerated grit removal basin. The design flow capacity of the headworks screen system is 5.5 mgd.

Two of three aeration basins are operated in parallel and complete mix modes. Wastewater moves by gravity from the headworks, combines with return activated sludge, and is routed into a split structure. The mixed liquor is split by weirs and runs into the two aeration basins through 12-inch pipelines. The combined volume of the two aeration basins is 0.8 million gallons.

In 2014, the Permittee completed the Biological Nutrient Removal project in the activated sludge facilities. The BNR process utilizes activated sludge biomass for nitrification, denitrification, and enhanced biological phosphorus removal in two BNR units. The activated sludge process is followed by clarification where

solids biomass and liquids are separated by sedimentation. Three clarifiers are utilized to remove solids from the mixed liquor suspension and produce a clear effluent. The combined flow of all three clarifiers is 3.5 mgd.

Clarified secondary effluent flows by gravity to the tertiary filters and UV disinfection system. Two tertiary filters operate (with one in service and one on standby) under a vacuum and use cloth media disk filtration technology featuring PA-13 nylon pile fabric. The capacity of each filter is 3.7 mgd, for a total of 7.4 mgd filtration capacity.

Disinfection is accomplished with a UV disinfection system capable of disinfecting flows up to 3.7 mgd. The infrastructure of the previous chlorine disinfection system, replaced by the UV disinfection system in October 2012, remains available for emergencies.

2.1.3. **Effluent Storage**

Tertiary treated effluent not meeting permit limits for turbidity or UV transmittance is automatically diverted to a 1 million gallon Emergency Holding Pond for retreatment. Fully treated effluent is placed in a 3.5 million gallon Effluent Storage Pond (or Holding Pond) prior to discharge to the Russian River or to the recycled water/land disposal system. During discharge to the Russian River, a control valve is used to adjust the flow from the Effluent Storage Pond through the Russian River Outfall line. The bottom of the effluent storage pond is at 39.0 feet elevation, while 0 feet of freeboard is at 57.0 feet elevation. To protect the pond from failure, an emergency overflow is set at 56.0 feet elevation. The effluent storage pond overflow pipe connects with the Russian River Outfall line after the control valve, but prior to the Russian River Outfall meter.

During periods of high influent flow, influent can be diverted to the 1 million gallon Emergency Holding Pond, or to the third aeration basin, which provides additional storage capacity of 0.4 million gallons during high flow events.

2.1.4. **Recycled Water and Land Disposal**

From May 15 through September 30, when discharges to the Russian River are prohibited, disinfected tertiary recycled water is used for irrigation of the Northwood Golf Course, located south of the Facility and on the opposite side of the Russian River. An average of 0.086 mgd is applied to an area of 43 acres during the irrigation season.

Treated wastewater not used by the Northwood Golf Course is disposed of through land disposal thorough spray irrigation on the upper and lower areas of the Burch property; 17 acres of wooded property adjacent to the Facility. During

the irrigation season approximately 0.103 mgd is applied to the property. This Order requires the Permittee to manage effluent irrigation on this land disposal area to minimize ponding, prevent runoff, and to protect groundwater.

Disinfected tertiary recycled water is also used for dust control on Facility roads and fire suppression at the Facility.

2.1.5. **Biosolids Management**

The majority of the biosolids generated during the treatment process are transferred back to the aeration basins as return activated sludge (RAS).

The remainder of the biosolids is dewatered by belt press to 15 percent solids or greater and transported to a municipal landfill by a contractor.

2.2. **Discharge Points and Receiving Waters**

2.2.1. The Facility is located within the Guerneville Hydrologic Subarea within the Lower Russian River Hydrologic Area.

2.2.2. Treated and disinfected effluent is typically discharged to the effluent storage pond at Discharge Point 001 prior to discharge to the Russian River at Discharge Point 002, distribution to the Northwoods Golf Course for water recycling at Discharge Point 004, or disposal to the Burch property at Discharge Point 003.

2.2.3. Disinfected tertiary treated wastewater is discharged from the Effluent Storage Pond at Discharge Point 002 to the Russian River, a water of the United States, during the allowed discharge period from October 1 to May 14. The Permittee may occasionally elect to discharge directly to the Russian River at Discharge Point 005 without utilizing the storage pond, such as when the storage pond requires maintenance or operational adjustments to ensure ongoing permit compliance. The rate of discharge is governed by flow conditions in the Russian River monitored at Hacienda Bridge and is limited to one percent of the flow of the Russian River. The average effluent discharge flow rate to the Russian River during the last six years was 0.626 mgd.

2.2.4. During the dry weather season from May 15 through September 30 and other periods as allowed under this Order, disinfected tertiary treated effluent from the Effluent Storage Pond may be distributed as disinfected tertiary recycled water for irrigation at the Northwood Golf Course at Discharge Point 004. Between May 15 and September 30, effluent not utilized by the golf course, is land applied at the Burch property at Discharge Point 003.

2.3. **Summary of Existing Requirements and SMR Data**

Effluent limitations contained in Order No. R1-2014-0002 for discharges from Discharge Point 001 (previous Monitoring Location EFF-001) and Discharge Point 002 (Monitoring Location EFF 002) and representative monitoring data from the term of Order No. R1-2014-0002 are as follows in Tables F-2 and F-3, below:

Table F-2. Historic Effluent Limitations and Monitoring Data at Discharge Point 001 (October 2014 – August 2020)

Parameter	Units	Average Monthly Limitation	Average Weekly Limitation	Maximum Daily Limitation	Highest Average Monthly Discharge	Highest Average Weekly Discharge	Highest Daily Discharge
Biochemical Oxygen Demand 5-day @ 20°C (BOD ₅)	mg/L	10	15	-	5.4	6.9	-
BOD ₅	lbs/day	60 ¹ /100 ²	90 ¹ /150 ²	-	47	71	-
BOD ₅	Percent Removal	85	-	-	96.3 ³	-	-
Total Suspended Solids (TSS)	mg/L	10	15	-	3.4	5.9	-
TSS	lbs/day	60 ¹ /100 ²	90 ¹ /150 ²	-	55	137 ⁸	-
TSS	Percent Removal	85	-	-	97.8 ³	-	-
pH	standard units	-	-	6.0 – 9.0 ⁴	-	-	7.0 – 7.6
Total Coliform Bacteria	MPN/100 mL	-	2.2 ⁵	23 ⁶ /240 ⁷	-	2 ⁵	280

Table Notes:

1. Based on the maximum sustained peak flow rate, during wet weather periods when the influent flow rate exceeds the dry weather design capacity of 0.71 mgd.

Parameter	Units	Average Monthly Limitation	Average Weekly Limitation	Maximum Daily Limitation	Highest Average Monthly Discharge	Highest Average Weekly Discharge	Highest Daily Discharge
<ol style="list-style-type: none"> 2. Based on the peak wet weather design capacity of the tertiary wastewater treatment filtration system of 0.71 mgd. 3. Represents the minimum observed percent removal. 4. Represents instantaneous minimum and instantaneous maximum effluent limits. 5. Expressed as a 7-day median. 6. The number of coliform bacteria shall not exceed an MPN of 23 per 100 mL in more than one sample in any 30-day period. 7. No sample shall exceed an MPN of 240 coliform bacteria per 100 mL. 8. Occurred during period of wet weather flow when the limit is 150 lb/day. 							

Table F-3. Historic Effluent Limitations and Monitoring Data – Discharge Point 002

Parameter	Units	Average Monthly Limitation	Average Weekly Limitation	Maximum Daily Limitation	Highest Average Monthly Discharge	Highest Average Weekly Discharge	Highest Daily Discharge
pH	standard units	-	-	6.5 – 8.5 ¹	-	-	6.5 – 8.0
Bis(2-ethylhexyl) Phthalate	µg/L	1.8	--	3.6	<3.0	--	<3.0
Ammonia, Total (as N)	mg/L	0.47 ²	--	1.2	<0.2	--	<0.2
Nitrate, Total (as N)	mg/L	10	--	17.2	8.1	--	8.1
Acute Toxicity	% Survival	70 ³ /90 ⁴	--	--	95 ⁵	--	--

Table Notes:

1. Represents instantaneous minimum and instantaneous maximum effluent limits.
2. Not to exceed 2.5 times the average monthly effluent limitation (AMEL) (i.e., 1.2 mg/L) as a 4-day average within 30 days, more than once in three years on average.
3. Minimum for one bioassay.
4. Median for any three consecutive bioassays.
5. Represents the minimum observed percent survival.

2.4. Compliance Summary

On May 9, 2016, the Executive Officer issued a Settlement Agreement and Stipulation for Entry of Administrative Civil Liability (ACL) Order No. R1-2016-0022 for two unauthorized discharges on May 23, 2010 and February 12, 2014, and 93 exceedances of effluent limitations for nitrate, dichlorobromomethane, total coliform organisms, and pH in Order Nos. R1-2010-0006 and R1-2014-0002. The ACL Complaint assessed a penalty of \$275,771 for these violations. The Permittee agreed to pay \$72,885 within 30 days of the issuance of Settlement Agreement and Stipulation for Entry of ACL Order No. R1-2016-0022. \$67,885 was suspended pending completion of an Enhanced Compliance Action (ECA) and the remaining \$135,000 was suspended pending completion of a Compliance Project (CP). The original ECA consisted of a manway installation on the force main at the main lift station, and the CP consisted of a tertiary filter upgrade project. The CP tertiary filter upgrade project was completed in accordance with the schedule in the ACL as documented in a final report dated October 30, 2018. In starting work on the ECA manway project, the Permittee determined that it would be more appropriate to replace the force main altogether, rather than to install a manway to inspect and assess the condition of the existing force main. Regional Water Board Staff accepted this proposal and allowed the Permittee to apply monies it had spent to date on the force main replacement project towards the offset penalty balance, paying the remainder to the Cleanup and Abatement Account (CAA). Accordingly, the Permittee has fulfilled its obligations under ACL Order No. R1-2016-0022.

Cease and Desist Order (CDO) No. R1-2014-0034 was adopted concurrently with Order No. R1-2014-0002. The CDO provided tasks and schedules to attain compliance with Land Discharge Specifications and Groundwater Limitations when discharging effluent at the Burch property, which the Permittee completed during the term of Order No. R1-2014-0002.

During the term of Order No. R1-2014-0002, the Permittee had one exceedance of the maximum total coliform effluent limitation of 240 MPN/100 mL when it recorded a result of 280 MPN/100 mL on November 19, 2015. In addition, the Permittee also had multiple SSOs from its collection system during wet weather periods in 2017 and 2019, a series of controlled overflows from the treatment plant between February 9 and 11, 2017, in violation of permit requirements, and a discharge after the permitted discharge season ended when late season rains prompted the need to discharge when the effluent storage pond filled and the ground was too wet to allow a land discharge to the Burch property nor recycled water distribution to the Northwood Golf Course. The spills are discussed in more detail in Fact Sheet section 6.3.6.2. Regional Water Board staff are developing an ACL to address these SSOs that occurred during the term of the 2014 Order.

2.5. **Recent and Planned Changes**

Over the current permit term, many projects have been completed as part of ongoing maintenance and improvements. The most significant projects completed at the WWTF include installing the BNR system; rehabilitating one tertiary filter and replacing the second tertiary filter; upgrading the grit pumps; replacing the “redwood” control tank; installing flow metering prior to the tertiary filters; installing flow metering on the filter backwash; replacing the diesel day tank for the emergency generator; replacing the spiral rag washers at the headworks; replacing the main electrical circuit breaker; replacing the polymer injection for the sludge belt press and replacing the upper irrigation motor control center and pumps.

Projects that the Permittee anticipates completing during the term of this Order include installing an influent flow magmeter; clarifier seismic retrofit, replacing the waste activated sludge (WAS) pumps, replacing the effluent pumps and installing a magmeter on the mixed liquor pipeline, and improving the sludge and grit loading area. The Permittee also has long-term capital improvement plan (CIP) projects that are anticipated to take more than five years to complete, including headworks and lift station improvements, collection system improvements, and force main replacement as further discussed in Fact Sheet section 2.1.1. The initiation and timing of these projects is contingent on available funding.

No other modifications or operational changes that will cause a material change in the volume or quality of discharges from the Facility have been identified for the term of this Order.

3. **APPLICABLE PLANS, POLICIES, AND REGULATIONS**

The requirements contained in this Order are based on the requirements and authorities described in this section.

3.1. **Legal Authorities**

This Order is issued pursuant to section 402 of the federal Clean Water Act (CWA) and implementing regulations adopted by the U.S. Environmental Protection Agency (U.S. EPA) and chapter 5.5, division 7 of the California Water Code (commencing with section 13370). It shall serve as a NPDES permit authorizing the Permittee to discharge into waters of the U.S. at the discharge location described in Table 2 subject to the WDRs in this Order. This Order also serves as WDRs pursuant to article 4, chapter 4, division 7 of the Water Code (commencing with section 13260) and Master Recycling Permit pursuant to article 4, chapter 4, division 7 of the Water Code (commencing with section 13500).

3.2. **California Environmental Quality Act (CEQA)**

Under Water Code section 13389, this action to adopt an NPDES permit is exempt from the provisions of Chapter 3 of CEQA, (commencing with section 21100) of Division 13 of the Public Resources Code. Accordingly, this exemption from CEQA applies to the Regional Water Board's action to adopt those portions of the Order that regulate NPDES discharges.

This action also involves the re-issuance of waste discharge requirements for an existing facility that discharges treated wastewater to land. The Regional Water Board's action in approving those parts of the Order that regulate WDR-related discharges is also exempt from CEQA as an existing facility for which no expansion of design flow is being permitted pursuant to title 14, CCR, section 15301.

Any minor alterations to irrigation system design are exempt from CEQA pursuant to title 14, CCR, section 15304 which applies to minor alterations to land, water, and/or vegetation where significant impacts are not expected.

When approving proposals for new recycled water sites, the Regional Water Board's action is subject to CEQA. Regional Water Board compliance with CEQA shall be addressed during the approval process for recycled water expansion areas set forth in Attachment G to this Order. The approval process requires demonstration that a CEQA analysis has been conducted for the recycled water use type and/or the geographical area of the recycled water use. The Permittee must also submit technical information necessary to demonstrate that any proposed recycled water use areas will be irrigated using the most stringent of the hydraulic and nutrient agronomic rate and include best management practices that are protective of surface and ground water quality, as described in Attachment G to this Order.

If a local agency (e.g., Permittee or other approved lead agency pursuant to CEQA regulations) has conducted an appropriate CEQA analysis, the Regional Water Board may review the CEQA document prepared by the local agency and make findings based on that document. If the local agency does not prepare a CEQA document, and the project is not otherwise exempt from CEQA requirements, the Regional Water Board could act as the lead agency under CEQA and prepare any necessary document to comply with CEQA, however, this could result in delays in project approval until such time that a proper CEQA analysis can be conducted by the Regional Water Board.

3.3. State and Federal Laws, Regulations, Policies, and Plans

3.3.1. Water Quality Control Plan

The Regional Water Board adopted a *Water Quality Control Plan for the North Coast Region* (hereinafter Basin Plan) that designates beneficial uses, establishes water quality objectives, and contains implementation programs and policies to achieve those objectives for all waters addressed through the plan. In addition, the Basin Plan implements State Water Resources Control Board (State Water Board) Resolution No. 88-63, which establishes State policy that all waters, with certain exceptions, should be considered suitable or potentially suitable for municipal or domestic supply (MUN).

In 1972, the State Water Board adopted a uniform list of beneficial uses, including descriptions, to be applied throughout all basins of the State. This list was updated in 1996. In addition to the beneficial uses identified on the statewide list, three wetland beneficial uses, recognizing the value of protecting these unique waterbodies have been identified in the North Coast Region: Wetland Habitat (WET); Water Quality Enhancement (WQE); and Flood Peak Attenuation/ Flood Water Storage (FLD). The Native American Cultural (CUL) use and Subsistence Fishing (FISH) use have also been added, identifying the traditional and cultural uses of waters within the North Coast Region.

Beneficial uses applicable to the Russian River, within the Guerneville Hydrologic Subarea of the Lower Russian River Hydrologic Area, are summarized in Table F-4, below:

Table F-4. Basin Plan Beneficial Uses

Discharge Point	Receiving Water Name	Beneficial Use(s)
002 and 005	Russian River within the Guerneville Hydrologic Subarea of the Lower Russian River Hydrologic Area	<p><u>Existing:</u> Municipal and domestic supply (MUN); Agricultural supply (AGR); Industrial service supply (IND); Groundwater recharge (GWR); Freshwater replenishment (FRSH); Navigation (NAV); Water contact recreation (REC-1); Non-contact water recreation (REC-2); Commercial and sport fishing (COMM); Warm Freshwater Habitat (WARM); Cold freshwater habitat (COLD); Wildlife habitat (WILD); Rare, threatened, or endangered species (RARE); Migration of aquatic organisms (MIGR); Spawning, reproduction, and/or early development (SPWN); and Estuarine habitat (EST).</p> <p><u>Potential:</u> Industrial process supply (PRO); Hydropower generation (POW); Shellfish Harvesting (SHELL), and Aquaculture (AQUA).</p>
003 and 004	Groundwater	<p><u>Existing:</u> Municipal and domestic supply (MUN); Agricultural supply (AGR); Industrial service supply (IND); and Native American culture (CUL).</p> <p><u>Potential:</u> Industrial process supply (PRO); Aquaculture (AQUA).</p>

In addition to the beneficial uses set out in the Basin Plan, there are several implementation plans that include actions intended to meet water quality objectives and protect beneficial uses of the North Coast Basin. For the Russian River and its tributaries, no point source waste discharges are allowed during the period of May 15 through September 30 and for all other periods, the receiving water flow must be at least 100 times greater than the waste flow

unless an exception to the requirements is granted by the Regional Water Board. Additionally, the discharge of municipal waste during October 1 through May 14 shall be of disinfected tertiary treated wastewater and shall meet a median coliform level of 2.2 MPN/100 mL.

Requirements of this Order implement the Basin Plan.

3.3.2. **National Toxics Rule (NTR) and California Toxics Rule (CTR)**

U.S. EPA adopted the NTR on December 22, 1992, and later amended it on May 4, 1995 and November 9, 1999. About forty criteria in the NTR applied in California. On May 18, 2000, U.S. EPA adopted the CTR. The CTR promulgated new toxics criteria for California and, in addition, incorporated the previously adopted NTR criteria that were applicable in the state. The CTR was amended on February 13, 2001. These rules contain federal water quality criteria for priority pollutants.

3.3.3. **State Implementation Policy**

On March 2, 2000, the State Water Board adopted the Policy for Implementation of Toxics Standards for Inland Surface Waters, Enclosed Bays, and Estuaries of California (State Implementation Policy or SIP). The SIP became effective on April 28, 2000, with respect to the priority pollutant criteria promulgated for California by the U.S. EPA through the NTR and to the priority pollutant objectives established by the Regional Water Board in the Basin Plan. The SIP became effective on May 18, 2000, with respect to the priority pollutant criteria promulgated by the U.S. EPA through the CTR. The State Water Board adopted amendments to the SIP on February 24, 2005, that became effective on July 13, 2005. The SIP establishes implementation provisions for priority pollutant criteria and objectives and provisions for chronic toxicity control. Requirements of this Order implement the SIP.

3.3.4. **Domestic Water Quality**

In compliance with Water Code section 106.3, it is the policy of the State of California that every human being has the right to safe, clean, affordable, and accessible water adequate for human consumption, cooking, and sanitary purposes. This Order promotes that policy by requiring discharges to meet maximum contaminant levels implemented by the Basin Plan that are designed to protect human health and ensure that water is safe for domestic use.

3.3.5. **Compliance Schedules and Interim Requirements.**

The State Water Board adopted Resolution No. 2008-0025 on April 15, 2008, titled *Policy for Compliance Schedules in National Pollutant Discharge Elimination System Permits*, which includes compliance schedule policies for pollutants that are not addressed by the SIP. This Policy became effective on August 27, 2008.

This Order does not include any compliance schedules or interim effluent limitations.

3.3.6. **Antidegradation Policy**

40 C.F.R. section 131.12 requires that the state water quality standards include an antidegradation policy consistent with the federal policy. The State Water Board established California's antidegradation policy in State Water Board Resolution No. 68-16. Resolution No. 68-16 incorporates the federal antidegradation policy where the federal policy applies under federal law. Resolution No. 68-16 requires that existing water quality be maintained unless degradation is justified based on specific findings. The Regional Water Board's Basin Plan implements, and incorporates by reference, both the state and federal antidegradation policies. The permitted discharge must be consistent with the antidegradation provision of 40 C.F.R. section 131.12 and State Water Board Resolution No. 68-16. As discussed in detail in section 4.4.2 of this Fact Sheet, the permitted discharge is consistent with the antidegradation provision of 40 C.F.R. section 131.12 and State Water Board Resolution No. 68-16.

3.3.7. **Anti-Backsliding Requirements**

Sections 402(o)(2) and 303(d)(4) of the CWA and federal regulations at 40 C.F.R. section 122.44(l) restrict backsliding in NPDES permits. These anti-backsliding provisions require that effluent limitations in a reissued permit must be as stringent as those in the previous permit, with some exceptions in which limitations may be relaxed. Some effluent limitations from the previous Order have been removed or are less stringent than those in the previous Order. As discussed in detail in section 4.4.1 of this Fact Sheet, removal or relaxation of effluent limitations is consistent with the anti-backsliding requirements of the CWA and federal regulations.

3.3.8. **Endangered Species Act Requirements**

This Order does not authorize an act that results in the taking of a threatened or endangered species or any act that is now prohibited, or becomes prohibited in the future, under either the California Endangered Species Act (Fish and Game Code sections 2050 to 2097) or the Federal Endangered Species Act (16

U.S.C.A sections 1531 to 1544). This Order requires compliance with effluent limits, receiving water limits, and other requirements to protect the beneficial uses of waters of the state. The Permittee is responsible for meeting all requirements of the applicable Endangered Species Act.

3.3.9. **Sewage Sludge and Biosolids**

This Order does not authorize any act that results in violation of requirements administered by U.S. EPA to implement 40 C.F.R. Part 503, Standards for the Use or Disposal of Sewage Sludge. These standards regulate the final use or disposal of sewage sludge that is generated during the treatment of domestic sewage in a municipal wastewater treatment facility. The Permittee is responsible for meeting all applicable requirements of 40 C.F.R. Part 503 that are under U.S. EPA's enforcement authority.

3.4. **Impaired Water Bodies on the CWA section 303(d) List**

Section 303(d) of the federal CWA requires states to identify waterbodies that do not meet water quality standards and are not supporting their beneficial uses after implementation of technology-based effluent limitations on point sources. Each state must submit an updated list, the 303(d) List of Impaired Waterbodies every two years. In addition to identifying the waterbodies that are not supporting beneficial uses, the 303(d) list also identifies the pollutant or stressor causing impairment and establishes a schedule for developing a control plan to address the impairment. The CWA requires development of a total maximum daily load (TMDL) or alternate program of implementation for each 303(d) listed pollutant and water body to remedy the impairment. TMDLs establish the maximum quantity of a given pollutant that can be added to a water body from all sources without exceeding the applicable water quality standard for that pollutant and determine wasteload allocations (the portion of a TMDL allocated to existing and future point sources) and load allocations (the portion of a TMDL attributed to existing and future nonpoint sources).

On April 6, 2018, the U.S. EPA provided final approval of the 2014 and 2016 303(d) List of Impaired Water Bodies prepared by the state. The list identifies the entire Russian River watershed as impaired by sedimentation/siltation and temperature, and the main stem Russian River from Fife Creek to Dutch Bill Creek as impaired by pathogenic indicator bacteria and aluminum. Pursuant to CWA section 303(d), the Regional Water Board will develop TMDLs to address the impairments, which will be implemented through various programs, including through provisions of NPDES permits.

On August 14, 2019, the Regional Water Board adopted the *Action Plan for the Russian River Watershed Pathogen TMDL* (TMDL Action Plan or Action Plan) and *Prohibition of the Discharge of Fecal Waste Materials* as an amendment to

the Basin Plan. The Action Plan describes the Program of Implementation designed to control fecal waste pollution, achieve bacterial water quality objectives, and restore the water contact recreation (REC-1) beneficial use to protect public health within the Russian River watershed. The Action Plan establishes wasteload allocations (WLAs) for point source discharges and load allocations (LAs) for nonpoint source discharges. Both WLAs and LAs are expressed as receiving water concentrations of *E. coli* bacteria in freshwater and enterococci in saline waters identical to the statewide bacteria objective for the protection of REC-1 for those sources that are permitted to discharge. For municipal wastewater discharges to freshwater surface waters within the Russian River Watershed, the *E. coli* bacteria WLAs are less than or equal to 100 colony forming units (CFU) per 100 milliliters (mL) as a six-week rolling geometric mean, calculated weekly, and a statistical threshold value (STV) of 320 cfu/ mL not to be exceeded more than ten percent of the time, calculated monthly. There are no municipal wastewater discharges to saline water in the Russian River Watershed, so therefore there are no applicable WLAs for enterococci bacteria.

For any direct discharges from the Facility to surface waters, the total coliform effluent limitations derived from title 22 requirements for disinfected tertiary recycled water are sufficient to ensure compliance with WLAs for *E. coli* bacteria because the title 22 total coliform limitations are more stringent than the applicable *E. coli* bacteria water quality objectives.

The TMDL Action Plan further identifies wastewater holding pond discharges to surface waters as a special area of concern due to the potential for regrowth of bacteria in these ponds. The Action Plan states that the Regional Water Board will begin to conduct reasonable potential analyses based on information submitted by the implementing party for entities that discharge wastewater from wastewater holding ponds to surface water. For discharges with reasonable potential to cause or contribute to an exceedance of the WLAs, water quality-based effluent limitations will be established in the applicable waste discharge requirements that will ensure compliance with WLAs for bacteria. This Order requires the Permittee to monitor for *E. coli* bacteria for discharges from storage ponds to surface waters and to conduct a Pathogen Special Study in order to develop data needed to assess whether or not the Permittee's discharge is a source of pathogens as defined in the TMDL Action Plan. If there is reasonable potential for pond discharges to exceed the *E. coli* bacteria water quality objectives, a pathogen source study is required to determine if bacteria discharged from the storage ponds is of human origin and, if so, effluent limitations would be established as soon as practicable.

Aspects of the sediment impairing the Russian River include settleable solids, suspended solids, and turbidity. The impact of settleable solids results when they collect on the bottom of a waterbody over time, making them a persistent or

accumulative constituent. The impact of suspended solids and turbidity, by contrast, results from their concentration in the water column. An analysis of the Permittee's effluent monitoring data for discharges to the Russian River indicates levels of BOD₅, TSS, and total coliform bacteria in the effluent are generally less than the effluent limitations required by this Order. Thus, the discharge does not typically contain sediment (e.g., settleable solids, suspended solids, and turbidity) at levels which will cause, have the reasonable potential to cause, or contribute to increases in sediment levels in the Russian River. This finding is based, in part, on the tertiary level of treatment provided by the Facility, which removes settleable solids and reduces TSS and turbidity to negligible levels in wastewater discharged to the Russian River. This finding is also supported by the summer discharge prohibition, the one percent flow limitation for the winter discharge, and previous solids and turbidity monitoring that has demonstrated that the Facility removes settleable solids and turbidity to negligible levels.

With regard to temperature, the critical time period for temperature is in the summer, which is also the time period when point source discharges from the Facility are prohibited. Because of the summer discharge prohibition, the Facility does not contribute to temperature loadings in the receiving water during the hottest, most critical season of the year.

3.5. Other Plans, Policies and Regulations

- 3.5.1. On May 2, 2006, the State Water Board adopted State Water Board Order No. 2006-0003 DWQ, *Statewide General Waste Discharge Requirements for Sanitary Sewer Systems* and on August 6, 2013 adopted Order No. WQ 2013-0058-EXEC *Amending Monitoring and Reporting Program for Statewide General Waste Discharge Requirements for Sanitary Sewer Systems*. Order No. 2006-0003-DWQ requires that all public agencies that currently own or operate sanitary sewer systems apply for coverage under the General WDRs. The deadline for dischargers to apply for coverage was November 2, 2006. The Permittee applied for coverage and is subject to the requirements of Order Nos. 2006-0003-DWQ and WQ 2013-0058-EXEC and any future revisions thereto for operation of its wastewater collection system.
- 3.5.2. Coverage under State Water Board Water Quality Order No. 2014-0057-DWQ, NPDES General Permit No. CAS000001, *General Permit for Storm Water Discharges Associated with Industrial Activities* (Industrial Storm Water General Permit) is not required based on the size of the Facility (less than 1 mgd). Stormwater run-on enters a storm drain that diverts stormwater from the property.
- 3.5.3. On July 22, 2004, the State Water Board adopted State Water Board Order No. 2004-0012 DWQ, *General Waste Discharge Requirements for the Discharge of Biosolids to Land for Use as a Soil Amendment in Agricultural, Silvicultural,*

Horticultural, and Recycled Water Activities. The Order requires the Permittee to obtain coverage under Order No. 2004-0012-DWQ prior to any removal of biosolids from the Facility that will be land disposed on property owned or controlled by the Permittee.

- 3.5.4. On February 3, 2009, the State Water Board adopted Resolution 2009-0011, *Adoption of a Policy for Water Quality Control for Recycled Water* (Recycled Water Policy) (Revised December 11, 2018, effective April 8, 2019) for the purpose of increasing the use of recycled water from municipal wastewater sources in a manner that implements state and federal water quality laws. The Recycled Water Policy provides direction to the regional water boards regarding the appropriate criteria to be used in issuing permits for recycled water projects and describes permitting criteria intended to streamline, and provide consistency for, the permitting of the vast majority of recycled water projects. Pertinent provisions and requirements of the Policy have been incorporated into this Order to address conditions specific to the Permittee's plan to implement water recycling.

The Recycled Water Policy recognizes the fact that some groundwater basins in the state contain salts and nutrients that exceed or threaten to exceed water quality objectives in the applicable Basin Plans, and that not all Basin Plans include adequate implementation procedures for achieving or ensuring compliance with the water quality objectives for salt or nutrients. The Recycled Water Policy further recognizes that these conditions can be caused by natural soils/conditions, discharges of waste, irrigation using surface water, groundwater or recycled water, and water supply augmentation using surface or recycled water, and that regulation of recycled water alone will not address these conditions. It is the intent of the Recycled Water Policy that salts and nutrients from all sources be managed on a basin-wide or watershed-wide basis in a manner that ensures attainment of water quality objectives and protection of beneficial uses. The Recycled Water Policy finds that the appropriate way to address salt and nutrient issues is through the development of regional or subregional Salt and Nutrient Management Plans (SNMPs) rather than through imposing requirements solely on individual recycled water projects. This Order is consistent with the requirements of the Recycled Water Policy to implement an SNMP.

- 3.5.5. When applicable, state law requires dischargers to file a petition with the State Water Board, Division of Water Rights, and receive approval for any change in the point of discharge, place of use, or purpose of use of treated wastewater that decreases the flow in any portion of the watercourse. The State Water Board retains separate jurisdictional authority to enforce any applicable requirements under Water Code section 1211. This is not an NPDES permit requirement.

4. RATIONALE FOR EFFLUENT LIMITATIONS AND DISCHARGE SPECIFICATIONS

The CWA requires point source dischargers to control the amount of conventional, non-conventional, and toxic pollutants that are discharged into the waters of the United States. The control of pollutants discharged is established through effluent limitations and other requirements in NPDES permits. There are two principal bases for effluent limitations in the Code of Federal Regulations: 40 C.F.R. section 122.44(a) requires that permits include applicable technology-based limitations and standards; and 40 C.F.R. section 122.44(d) requires that permits include water quality-based effluent limitations (WQBELs) to attain and maintain applicable numeric and narrative water quality criteria to protect the beneficial uses of the receiving water where a reasonable potential to exceed those criteria exists.

4.1. Discharge Prohibitions

- 4.1.1. **Discharge Prohibition 3.1.** The discharge of any waste not disclosed by the Permittee or not within the reasonable contemplation of the Regional Water Board is prohibited.

This prohibition has been retained from Order No. R1-2014-0002 and is based on the Basin Plan and State Water Board Order No. WQO 2002-0012 regarding the petition of WDRs Order No. 01-072 for the East Bay Municipal Utility District and Bay Area Clean Water Agencies. In State Water Board Order No. WQO 2002-0012, the State Water Board found that this prohibition is acceptable in Orders, but should be interpreted to apply only to constituents that are either not disclosed by the Permittees, or are not reasonably anticipated to be present in the discharge but have not been disclosed by the Permittees. It specifically does not apply to constituents in the discharge that do not have “reasonable potential” to exceed water quality objectives.

The State Water Board has stated that the only pollutants not covered by this prohibition are those which were “*disclosed to the permitting authority and...can be reasonably contemplated.*” [In re the Petition of East Bay Municipal Utilities District et al., (State Water Board, 2002) Order No. WQO 2002-0012, p. 24]. In that Order, the State Water Board cited a case which held the Permittee is liable for the discharge of pollutants “*not within the reasonable contemplation of the permitting authority...whether spills or otherwise...*” [Piney Run Preservation Assn. v. County Commissioners of Carroll County, Maryland (4th Cir. 2001) 268 F. 3d 255, 268.] Thus, the State Water Board authority provides that, to be permissible, the constituent discharged (1) must have been disclosed by the Permittees and (2) can be reasonably contemplated by the Regional Water Board.

- 4.1.2. **Discharge Prohibition 3.2.** Creation of pollution, contamination, or nuisance, as defined by section 13050 of the Water Code is prohibited.

This prohibition has been retained from Order No. R1-2014-0002 and is based on section 13050 of the Water Code and section 5411 of the California Health and Safety Code.

- 4.1.3. **Discharge Prohibition 3.3.** The discharge of sludge or digester supernatant is prohibited, except as authorized under section 6.3.5.3 of this Order (Sludge Disposal and Handling Requirements).

This prohibition has been retained from Order No. R1-2014-0002 and is based on restrictions on the disposal of sewage sludge found in federal regulations [40 C.F.R. part 503 (Biosolids), part 527, and part 258] and title 27 of the CCR.

- 4.1.4. **Discharge Prohibition 3.4.** The discharge of untreated or partially treated waste (receiving a lower level of treatment than described in section 2.1 of the Fact Sheet) from anywhere within the collection, treatment, or disposal systems is prohibited, except as provided for in Attachment D, Standard Provisions 1.7 (Bypass) and 1.8 (Upset).

This prohibition has been retained from Order No. R1-2014-0002 with a minor modification. The term “reclamation” has been replaced with the term “recycling.” This prohibition is based on the Basin Plan to protect the beneficial uses of the receiving water from unpermitted discharges, and the intent of the Water Code sections 13260 through 13264 relating to the discharge of waste to waters of the state without filing for and being issued an Order. This prohibition applies to spills not related to sanitary sewer overflows (SSOs) and other unauthorized discharges of wastewater within the collection, treatment, and disposal facilities. The discharge of untreated or partially treated wastewater from the collection, treatment, or disposal facility represents an unauthorized bypass pursuant to 40 C.F.R. section 122.41(m) or an unauthorized discharge, which poses a threat to human health and/or aquatic life, and therefore is explicitly prohibited by this Order.

- 4.1.5. **Discharge Prohibition 3.5.** Any sanitary sewer overflow (SSO) that results in a discharge of untreated or partially treated wastewater to (a) waters of the state or (b) land that creates pollution, contamination, or nuisance, as defined in Water Code section 13050(m) is prohibited.

This prohibition is retained from Order No. R1-2014-0002. The prohibition applies to spills related to SSOs and is based on state standards, including section 13050 of the Water Code and the Basin Plan. This prohibition is consistent with the state’s antidegradation policy as specified in State Water Board Resolution No. 68-16 (*Statement of Policy with Respect to Maintaining*

High Quality of Water in California) in that the prohibition imposes conditions to prevent impacts to water quality, the degradation of water quality, negative effects on receiving water beneficial uses, and lessening of water quality beyond that prescribed in State Water Board or Regional Water Board plans and policies.

This prohibition is stricter than the prohibitions stated in State Water Board Order No. 2006-0003-DWQ, *Statewide General Waste Discharge Requirements for Sanitary Sewer Systems*. Order No. 2006-0003-DWQ prohibits SSOs that result in the discharge of untreated or partially treated wastewater to waters of the United States and SSOs that cause a nuisance, compared to Prohibition 3.5 of this Order, which prohibits SSO discharges that create nuisance or pollution to waters of the state and land for a more complete protection of human health. The rationale for this prohibition is based on the prevalence of high groundwater in the North Coast Region, and this Region's reliance on groundwater as a drinking water source.

- 4.1.6. **Discharge Prohibition 3.6.** The discharge of waste to land that is not owned by the Permittee, governed by District ordinance, or under agreement to use by the Permittee, or for which the Permittee has explicitly permitted such use, is prohibited, except for use for fire suppression as provided in title 22, sections 60307(a) and 60307(b) of the CCR.

This prohibition is retained from Order No. R1-2014-0002. Land used for the application of wastewater must be owned by the Permittee or be under the control of the Permittee by contract so that the Permittee maintains a means for ultimate disposal of treated wastewater.

- 4.1.7. **Discharge Prohibition 3.7.** The discharge of waste at any point not described in Finding 2.2 of the Fact Sheet or authorized by a permit issued by the State Water Board or another Regional Water Board is prohibited.

This prohibition has been retained from Order No. R1-2014-0002. This prohibition is a general prohibition that allows the Permittee to discharge waste only in accordance with WDRs. It is based on sections 301 and 402 of the federal CWA and section 13263 of the Water Code.

- 4.1.8. **Discharge Prohibition 3.8.** The average dry weather flow (ADWF) of waste through the Facility shall not exceed 0.51 million gallons per day (mgd), measured daily and averaged over a calendar month, unless the Permittee demonstrates that it has storage and recycled water capacity to handle a higher ADWF, not to exceed 0.71 mgd. The peak daily wet weather flow of waste through the tertiary wastewater treatment system shall not exceed 3.5 mgd, measured daily. Compliance with this prohibition shall be determined as defined in sections 7.11 and 7.12 of this Order.

The average dry weather flow prohibition is retained from Order No. R1-2014-0002 and is based on the storage and disposal capacity of the Facility. The peak daily wet weather flow prohibition is also retained from Order No. R1-2014-0002 and based on the peak wet weather treatment capacity of the Facility. Exceedance of these capacities on a daily basis may result in effluent violations and/or the need to bypass untreated effluent blended with treated effluent, which is prohibited.

- 4.1.9. **Discharge Prohibition 3.9.** The discharge of waste to the Russian River and its tributaries is prohibited during the period from May 15 through September 30 of each year.

This prohibition is retained from Order No. R1-2014-0002 and is required by the Basin Plan. The Basin Plan prohibits discharges to the Russian River and its tributaries during the period May 15 through September 30 (chapter 4, Waste Discharge prohibitions for the North Coast Basin). The original intent of this prohibition was to prevent the contribution of wastewater to the baseline flow of the Russian River during the period of the year when the Russian River and its tributaries experience the heaviest water-contact recreation use.

- 4.1.10. **Discharge Prohibition 3.10.** During the period from October 1 through May 14, discharges of treated wastewater to the Russian River shall not exceed one percent of the flow of the Russian River, as measured at USGS Gauge No. 11-4670.00 at Hacienda Bridge. For the purposes of this Order, compliance with this discharge prohibition shall be determined as follows:

- 4.1.10.1. The discharge of disinfected tertiary treated wastewater shall be adjusted at least once daily to avoid exceeding, to the extent practicable, one percent of the most recent daily flow measurement of the Russian River at USGS Gauge No. 11-4670.00. Daily flow shall be based on flow meter comparisons reasonably read between the hours of 12:01 am and 12:00 midnight; and
- 4.1.10.2. In no case shall the total volume of disinfected tertiary treated wastewater discharged in a calendar month exceed one percent of the total volume of the Russian River measured at USGS Gauge No. 11-4670.00 in the same calendar month. At the beginning of the discharge season, the monthly flow volume comparisons shall be based on the date when the discharge commenced to the end of the calendar month. At the end of the discharge season, the monthly flow volume comparisons shall be based on the first day of the calendar month to the date when the discharge ceased for the season.

This prohibition has been retained from Order No. R1-2014-0002 and is required by the Basin Plan (chapter 4, North Coastal Basin Discharge Prohibition No. 4). The Basin Plan prohibits discharges to the Russian River and its tributaries when the waste discharge flow is greater than one percent of

the receiving water's flow. Basin Plan Prohibition No. 4 does not specify how compliance with the one-percent flow requirement will be determined. This prohibition specifies that the discharge may comply with the one percent requirement as a monthly average for the surface water discharge season if a reading at USGS Gauge No. 11 4670.00 is taken at least once daily, and the discharge flow rate shall not be set for greater than one percent of the flow of the river at the time of the daily reading.

- 4.1.11. **Discharge Prohibition 3.11.** The discharge of any radiological, chemical, or biological warfare agent into waters of the state is prohibited under Water Code section 13375.

This prohibition is retained from Order No. R1-2014-0002 and is based on the discharge prohibitions contained in section 13375 of the Water Code as well as 33 U.S. Code section 1311.

- 4.1.12. **Discharge Prohibition 3.12.** The acceptance of septage to a location other than an approved septage receiving station and in accordance with a septage management program approved by the Regional Water Board Executive Officer is prohibited.

This prohibition is newly established by this Order and is necessary to ensure that septage is not accepted in the absence of a septage management program to ensure that pollutants associated with domestic septage do not pass through or interfere with the operation or performance of the Facility.

4.2. **Technology-Based Effluent Limitations**

4.2.1. **Scope and Authority**

Section 301(b) of the CWA and implementing U.S. EPA permit regulations at 40 C.F.R. section 122.44 require that permits include conditions meeting applicable technology-based requirements at a minimum, and any more stringent effluent limitations necessary to meet applicable water quality standards. The discharge authorized by this Order must meet minimum federal technology-based requirements based on Secondary Treatment Standards at 40 C.F.R. part 133.

In addition, 40 C.F.R. section 122.45(d)(2) states that technology-based permit limits shall be stated as average weekly and average monthly discharge limitations, unless impracticable, for POTWs. 40 C.F.R. section 103.102 provides detailed specifications for establishing effluent limitations for the technology-based constituents, BOD₅, TSS, and pH. Effluent limitations for BOD₅, TSS, and pH in Effluent Limitations 4.1.1.1, Table 2 and 4.1.1.2 of this

Order were established as required by 40 C.F.R. section 103.102 and have been retained in this Order.

Regulations promulgated in 40 C.F.R. section 125.3(a)(1) require technology-based effluent limitations for municipal dischargers to be placed in NPDES permits based on Secondary Treatment Standards or Equivalent to Secondary Treatment Standards.

The Federal Water Pollution Control Act Amendments of 1972 (PL 92-500) established the minimum performance requirements for POTWs [defined in section 304(d)(1)]. Section 301(b)(1)(B) of that Act requires that such treatment works must, as a minimum, meet effluent limitations based on secondary treatment as defined by the U.S. EPA Administrator.

Based on this statutory requirement, U.S. EPA developed secondary treatment regulations, which are specified in 40 C.F.R. part 133. These technology-based regulations apply to all municipal wastewater treatment plants and identify the minimum level of effluent quality attainable by secondary treatment in terms of BOD₅, TSS, and pH, as follows:

4.2.1.1. **BOD₅ and TSS**

4.2.1.1.1. The 30-day average shall not exceed 30 mg/L.

4.2.1.1.2. The 7-day average shall not exceed 45 mg/L.

4.2.1.1.3. The 30-day average percent removal shall not be less than 85%.

4.2.1.2. **pH**

4.2.1.2.1. The pH shall be maintained within the limits of 6.0 to 9.0.

4.2.1.2.2. The effluent limitation for pH required to meet the water quality objective is contained in the Basin Plan, Table 3-1.

In addition, 40 C.F.R. section 122.45(f) requires the establishment of mass-based effluent limitations for all pollutants limited in Orders, except for 1) pH, temperature, radiation, or other pollutants, which cannot be appropriately expressed by mass, 2) when applicable standards and limitations are expressed in terms of other units of measure.

4.2.2. **Applicable Technology-Based Effluent Limitations**

The effluent limitations in this Order for BOD₅, TSS, and pH not only meet the technology-based requirements for secondary treatment set forth in section

133.102, but they also are required to meet the water quality-based requirements set forth in the Basin Plan.

In addition to the minimum federal technology-based requirements, the Basin Plan requires that discharges of municipal waste “*shall be of advanced treated wastewater in accordance with effluent limitations contained in NPDES permits for each affected discharger, and shall meet a median coliform level of 2.2 MPN/100 mL*” for discharges to the Russian River and its tributaries during October 1 through May 14. This requirement leaves discretion to the Regional Water Board to define advanced wastewater treatment by the implementation of effluent limitations in individual permits. This Order uses the terms “disinfected tertiary wastewater” and “disinfected tertiary recycled water” in place of the term “advanced treated wastewater”.

- 4.2.2.1. **BOD₅ and TSS.** As described above, the secondary treatment standards at 40 C.F.R. part 133 establish the minimum level of effluent quality attainable by secondary treatment in terms of BOD₅, TSS, and pH. For the purpose of regulating municipal waste discharges from the Facility to the Russian River, tertiary wastewater treatment is defined as achieving a monthly average concentration for BOD₅ and TSS of 10 mg/L, and a weekly average concentration of 15 mg/L, which are technically achievable based on the capability of a tertiary treatment system. In addition, 40 C.F.R. 133.102, in describing the minimum level of effluent quality attainable by secondary treatment, states that the 30-day average percent removal shall not be less than 85 percent. These effluent limitations are retained from Order No. R1-2014-0002.
- 4.2.2.2. **pH.** The secondary treatment regulations at 40 C.F.R. part 133 require that pH be maintained between 6.0 and 9.0 standard units. This technology based effluent limitation is applied to discharges from the treatment system to the Effluent Storage Pond at Discharge Point 001. Note that a more stringent effluent limitation range of 6.5 – 8.5 for pH is required to meet the water quality objective for hydrogen ion concentration (pH) in the Russian River contained in Basin Plan, Table 3 1. This WQBEL is applied to discharges from the effluent storage pond or direct discharges to the Russian River.
- 4.2.2.3. **Mass-Based Effluent Limitations.** Federal regulations at 40 C.F.R. section 122.45(f) require that, except under certain conditions, all permit limits, standards, or prohibitions be expressed in terms of mass units. Among the conditions exempting the application of mass-based limitations is 40 C.F.R. section 122.45(f)(1)(i), which states “*for pH, temperature, and radiation, or other pollutants which cannot appropriately be expressed by mass*” and 40 C.F.R. section 122.45(f)(1)(ii), which states “*when applicable standards and limitations are expressed in terms of other units of measurement.*”

This Order does not include mass-based effluent limitations for the following pollutants pursuant to the exceptions in 40 C.F.R. section 122.45(f)(1)(i) and (ii):

- 4.2.2.3.1. BOD₅ and TSS, because these two parameters are expressed in terms of concentration and percent removal; and
- 4.2.2.3.2. pH, because this parameter cannot appropriately be expressed by mass.
- 4.2.2.4. **Coliform Bacteria.** Even though effluent limits for coliform bacteria are not set out in the federal regulations for secondary treatment, they are included here in the section on technology-based effluent limitations because they reflect technology standards for tertiary treatment. Coliform bacteria are a pollutant of concern in all wastewaters of domestic origin, and therefore this Order retains the effluent limitations for total coliform bacteria from Order No. R1-2014-0002. These effluent limitations reflect standards for tertiary treated effluent in the Basin Plan (section 4, Implementation Plans) and as adopted by the State Water Board, DDW in title 22 of the CCR.

4.3. **Water Quality-Based Effluent Limitations (WQBELs)**

4.3.1. **Scope and Authority**

CWA section 301(b) and 40 C.F.R. section 122.44(d) require that permits include limitations more stringent than applicable federal technology-based requirements where necessary to achieve applicable water quality standards. This Order contains requirements, expressed as technology equivalence requirements that are necessary to meet applicable water quality standards. The rationale for these requirements, which consist of disinfected tertiary wastewater treatment, is discussed in section 4.2.2 of this Fact Sheet. In addition, this Order contains additional requirements to meet applicable water quality standards. The rationale for these requirements is discussed in section 4.3.3 of this Fact Sheet.

Section 122.44(d)(1)(i) of 40 C.F.R. requires that permits include effluent limitations for all pollutants that are or may be discharged at levels that have the reasonable potential to cause or contribute to an exceedance of a water quality standard, including numeric and narrative objectives within a standard. Where reasonable potential has been established for a pollutant, but there is no numeric criterion or objective for the pollutant, WQBELs must be established using: (1) U.S. EPA criteria guidance under CWA section 304(a), supplemented where necessary by other relevant information; (2) an indicator parameter for the pollutant of concern; or (3) a calculated numeric water quality criterion, such as a proposed state criterion or policy interpreting the state's narrative criterion,

supplemented with other relevant information, as provided in section 122.44(d)(1)(vi).

The process for determining reasonable potential and calculating WQBELs when necessary is intended to protect the designated uses of the receiving water as specified in the Basin Plan and achieve applicable water quality objectives and criteria that are contained in other state plans and policies, or any applicable water quality criteria contained in the CTR and NTR.

4.3.2. **Applicable Beneficial Uses and Water Quality Criteria and Objectives**

4.3.2.1. **Beneficial Uses.** Beneficial use designations for receiving waters for discharges from the Facility are presented in section 3.3.1 of this Fact Sheet.

4.3.2.2. **Basin Plan Water Quality Objectives.** In addition to the specific water quality objectives indicated above, the Basin Plan contains narrative objectives for color, tastes and odors, floating material, suspended material, settleable material, oil and grease, biostimulatory substances, sediment, turbidity, pH, dissolved oxygen, bacteria, temperature, toxicity, pesticides, chemical constituents, and radioactivity that apply to inland surface waters, enclosed bays, and estuaries, including the Russian River and its tributaries. For waters designated for use as MUN, the Basin Plan establishes, as applicable water quality criteria, the MCLs established by DDW for the protection of public water supplies at title 22 of the CCR section 64431 (Inorganic Chemicals) and section 64444 (Organic Chemicals).

4.3.2.3. **SIP, CTR, and NTR.** Water quality criteria and objectives applicable to the Russian River are established by the CTR, established by the U.S. EPA at 40 C.F.R. section 131.38; and the NTR, established by the U.S. EPA at 40 C.F.R. section 131.36. Criteria for most of the 126 priority pollutants are contained within the CTR and the NTR.

The SIP, which is described in section 3.3.3 of this Fact Sheet, includes procedures for determining the need for, and the calculation of, WQBELs and requires Permittees to submit data sufficient to do so.

At title 22, division 4, chapter 15 of the CCR, DDW has established MCLs for certain pollutants for the protection of drinking water. Chapter 3 of the Basin Plan establishes these MCLs as water quality objectives applicable to receiving waters with the beneficial use designation of municipal and domestic supply.

Aquatic life freshwater and saltwater criteria are identified as criterion maximum concentrations (CMC) and criterion continuous concentrations (CCC). The CTR defines the CMC as the highest concentration of a pollutant

to which aquatic life can be exposed for a short period of time without deleterious effects and the CCC as the highest concentration of a pollutant to which aquatic life can be exposed for an extended period of time (4 days) without deleterious effects. The CMC is used to calculate an acute or 1-hour average numeric effluent limitation and the CCC is used to calculate a chronic or 4-day average numeric effluent limitation. Aquatic life freshwater criteria were used for the RPA.

Human health criteria are further identified as “water and organisms” and “organisms only”. “Water and organism” criteria are designed to address risks to human health from multiple exposure pathways. The criteria from the “water and organisms” column of the CTR were used for the RPA because the Basin Plan identifies that the receiving water, the Russian River, has the beneficial use designation of municipal and domestic supply.

4.3.3. **Determining the Need for WQBELs**

NPDES regulations at 40 C.F.R. section 122.44(d) require effluent limitations to control all pollutants, which are or may be discharged at a level that will cause, have the reasonable potential to cause, or contribute to an excursion above any state water quality standard.

For WQBELs for toxic pollutants, Section 5.2.3 of the EPA Technical Support Document for Water Quality-based Toxic Controls states *“in lieu of an Average Weekly Limit (AWL) for POTWs, EPA recommends establishing a Maximum Daily Limit (MDL) (or a maximum test result for chronic toxicity) for toxic pollutants and pollutant parameters in water quality permitting. This is appropriate for at least two reasons. First, the basis for the 7-day average for POTWs derives from the secondary treatment requirements. This basis is not related to the need for assuring achievement of water quality standards. Second, a 7-day average, which could comprise up to seven or more daily samples, could average out peak toxic concentrations and therefore the discharge’s potential for causing acute toxic effects would be missed. A MDL, which is measured by a grab sample, would be toxicologically protective of potential acute toxicity impacts.”*

Section 1.4 of the SIP states that maximum daily effluent limitations (MDEL) shall be used for POTWs in place of average weekly effluent limitations (AWEL) for WQBELs. The SIP procedure of calculating an AMEL and an MDEL applies to all CTR pollutants, both those that are for protection of aquatic life and those that are for the protection of human health.

The RPA for discharges from the effluent storage pond to the Russian River at Discharge Point 002 was conducted as follows.

4.3.3.1. **Non-Priority Pollutants**

- 4.3.3.1.1. **pH.** The effluent limitation for pH of 6.5 to 8.5 is retained from Order No. R1-2014-0002. This limitation is based on the water quality objective for all surface waters established in chapter 3, Table 3-1 of the Basin Plan. Federal technology-based requirements prescribed in 40 C.F.R. part 133 are not sufficient to meet these Basin Plan water quality standards.
- 4.3.3.1.2. **Nitrogen Compounds.** Untreated domestic wastewater contains ammonia nitrogen. Nitrification is a biological process that converts ammonia to nitrite and nitrate. Denitrification is a process that converts nitrate to nitrogen gas, which is then released to the atmosphere. Inadequate or incomplete nitrification may result in the discharge of ammonia to the receiving stream and inadequate or incomplete denitrification may result in the discharge of nitrate to the receiving stream. The activated sludge components of the Facility are designed for BNR. The BNR process utilizes activated sludge biomass for nitrification, denitrification, and enhanced biological phosphorus removal.
- 4.3.3.1.2.1. **Nitrate.** Nitrate is known to cause adverse health effects in humans. For waters designated as domestic or municipal supply, the Basin Plan (Chapter 3) adopts the MCLs, established by DDW for the protection of public water supplies at title 22 of the CCR, sections 64431 (Inorganic Chemicals) and 64444 (Organic Chemicals), as applicable water quality criteria. The MCL for nitrate (10 mg/L as N) is therefore applicable as a water quality criterion. The Permittee sampled its discharge at Monitoring Location EFF-002 monthly between October 2014 and May 2020, following the completion of the Facility's upgrade. Monitoring results ranged from 0.2 mg/L to 8.1 mg/L based on 52 samples. Because nitrate levels in the effluent and background receiving water have been measured at concentrations lower than 10 mg/L, as N, and the discharge rate cannot exceed one percent of the Russian River flow, the Regional Water Board concludes that discharges from the Facility do not have a reasonable potential to cause or contribute to exceedances of applicable water quality criteria for the receiving water.
- 4.3.3.1.2.2. **Ammonia.** Ammonia is known to cause toxicity to aquatic organisms in surface waters. The Basin Plan establishes a narrative water quality objective for toxicity, stating that "[a]ll waters shall be maintained free of toxic substances in concentrations that are toxic to, or that produce detrimental physiological responses in human, plant, animal, or aquatic life." Due to concerns regarding ammonia toxicity, the Regional Water Board relies on U.S. EPA's recommended water quality criteria for ammonia to interpret the Basin Plan's narrative objective for toxicity. For freshwater, the recommended criteria are from the April 2013 *Aquatic Life*

Ambient Water Quality Criteria for Ammonia – Freshwater, EPA 822-R-13-001 (2013 Freshwater Criteria). The 2013 Freshwater Criteria is an update to the December 1999 *Update of Ambient Water Quality Criteria for Ammonia* (1999 Freshwater Criteria).

The 2013 Freshwater Criteria recommends acute and chronic water quality criteria for the protection of aquatic life, including salmonids and sensitive freshwater mussel species in the Family Unionidae that are more sensitive to ammonia than salmonids. Like the 1999 Freshwater Criteria document, the 2013 Freshwater Criteria document recommends acute (1-hour average) criteria based on pH and the presence/absence of salmonids and chronic (30 day average) criteria based on pH and temperature and that no 4-day average concentration should exceed 2.5 times the 30-day chronic criterion. In addition, the 2013 Freshwater Criteria document recommends these same criteria for sensitive mussel species.

For this Order, the Regional Water Board has considered the actual conditions documented in the receiving water for discharges from the Facility (paired receiving water pH of 8.5 and temperature of 16.8°C, the assumed presence of salmonids, and the assumed presence of mussels) to calculate U.S. EPA's 2013 Freshwater Criteria, which result in acute and chronic criteria of 1.8 mg/L and 0.40 mg/L, respectively.

All 52 ammonia samples collected at Monitoring Location EFF-002 between October 2014 and May 2020 were non-detect. Therefore, the discharge does not demonstrate reasonable potential to cause or contribute to an in-stream excursion above EPA's 2013 Freshwater Criteria, and WQBEL's for ammonia have not been included in this Order. This Order requires monthly effluent monitoring for ammonia when discharging from Discharge Points 002 and 005. Should monitoring results indicate that the discharge has the reasonable potential to cause or contribute to an exceedance of a water quality standard, this Order may be reopened and modified by adding appropriate effluent limitations.

- 4.3.3.1.3. **Biostimulatory Substances (Phosphorus and Nitrogen).** The Basin Plan contains a narrative water quality objective for biostimulatory substances that states “[w]aters shall not contain biostimulatory substances in concentrations that promote aquatic growths to the extent that such growths cause nuisance or adversely affect beneficial uses.” The Regional Water Board is increasingly concerned about the biostimulatory properties of discharges to surface waters in the North Coast Region. Nutrients, such as phosphorus and nitrogen containing compounds, in treated wastewater stimulate the growth rate of photosynthetic bacteria, algae, and other aquatic plants. The overabundance of nitrogen and phosphorus compounds

in surface water bodies can result in the excessive growth and decay of these organisms, thus accelerating the process of eutrophication. These phenomena cause dissolved oxygen levels to drop below concentrations needed for the survival and health of fish and aquatic life, which in turn negatively affects the aesthetic quality of water bodies and impairs beneficial uses.

At present, for interpretation of the Basin Plan's narrative water quality objective for biostimulatory substances, U.S. EPA has established recommended water quality criteria for nutrients in *Nutrient Criteria Documents for Lakes and Rivers and Nutrient Criteria Documents for Rivers and Streams*. U.S. EPA has defined 14 "ecoregions" and further categorized surface waters as lakes and reservoirs or rivers and streams for purposes of defining applicable numeric water quality criteria for nutrients. The State and Regional Water Boards continue to examine other methods of interpreting the Basin Plan's narrative water quality objective for biostimulatory substances. When the Boards determine that U.S. EPA's recommended criteria are appropriate for implementing the Basin Plan objectives, or when a more appropriate and meaningful method is established, the need for limiting nutrients in relation to biostimulatory properties, including phosphorus and nitrogen-containing compounds, in all discharges in the Region will be reassessed. In the meantime, the RPA for nutrients in relation to biostimulatory properties, performed for development of this Order, is inconclusive. The Order retains monitoring requirements for phosphorus and nitrogen containing compounds in discharges from the Facility to allow a determination of reasonable potential at such time as the State and Regional Water Boards select an appropriate method for interpretation of the Basin Plan's narrative objective.

4.3.3.1.4. **Pathogens (*E. coli* bacteria).** On August 7, 2018, the State Water Board adopted Part 3 of the *Water Quality Control Plan for Inland Surface Waters, Enclosed Bays, and Estuaries of California – Bacteria Provisions and a Water Quality Standards Variance Policy* (Statewide Bacteria Provisions), which establishes water quality objectives for reasonable protection of people that recreate within all surface waters, enclosed bays, and estuaries of the state that have the water contact recreation beneficial use (REC-1). In accordance with the water quality objectives outlined in the Statewide Bacteria Provisions for the protection of freshwaters used for water contact recreation, disinfected effluent shall not contain *E. coli* bacteria exceeding the following limitations:

4.3.3.1.4.1. The concentration of *E. coli* bacteria shall not exceed 100 colony forming units (cfu) per 100 milliliters (mL) as a six-week rolling geometric mean, calculated weekly.

- 4.3.3.1.4.2. A statistical threshold value (STV) of 320 cfu/100 mL shall not be exceeded by more than 10 percent of the samples collected in a calendar month and calculated in a static manner.

As discussed in section 4.2.2.4 of this Fact Sheet, this Order contains effluent limitations for total coliform bacteria that reflect standards for tertiary treated effluent in the Basin Plan (section 4, Implementation Plans) and as adopted by the State Water Board, DDW in title 22 of the CCR. Because *E. coli* bacteria is a subset of the total coliform group, the *E. coli* bacteria limitations established in the Statewide Bacteria Provisions are not as stringent as the title 22 total coliform standards implemented in this Order for assessment of treatment performance. POTWs utilizing more stringent effluent limitations based on title 22 are not required to comply with the less stringent bacteria water quality objectives for protection of water contact recreation, so the effluent limitations from the Statewide Bacteria Provisions have not been included in this Order. The effluent limitations established for total coliform will ensure that bacterial standards for water contact recreation are maintained throughout the receiving water.

The Order includes special study (Order section 6.3.2.2) monitoring requirements for *E. coli* bacteria in pond discharges from the Facility to assess the Facility's ability to comply with the bacteria water quality objectives specified in Order section 5.1.20 and required actions outlined in the Russian River Pathogen TMDL Action Plan. *E. coli* bacteria monitoring data collected during this permit term will be used to allow a determination of reasonable potential during the development of the next permit.

- 4.3.3.1.5. **Aluminum.** Aluminum is known to cause toxicity to aquatic organisms in surface waters. The Basin Plan establishes a narrative water quality objective for toxicity, stating that “[a]ll waters shall be maintained free of toxic substances in concentrations that are toxic to, or that produce detrimental physiological responses in human, plant, animal, or aquatic life.” Due to concerns regarding aluminum toxicity, the Regional Water Board relies on U.S. EPA’s recommended water quality criteria for aluminum to interpret the Basin Plan’s narrative objective for toxicity. For freshwater, the recommended criteria are from the December 2018 *Aquatic Life Ambient Water Quality Criteria for Aluminum* EPA 822-R-18-001 (2018 National Ambient Water Quality Criteria (NAWQC)). The 2018 Aluminum Criteria supersedes the August 1988 *Ambient Water Quality Criteria for Aluminum* (1988 NAWQC), which established water quality objectives for the protection of freshwater aquatic life for aluminum of 750 µg/L (acute) and 87 µg/L (chronic).

The 2018 Aluminum Criteria reflect the latest science and allow for development of criteria reflecting the impact of local receiving water chemistry on aluminum toxicity to aquatic life. The updated criteria account for the site-specific bioavailability of aluminum in receiving waters, which is dependent on pH, dissolved organic carbon, and hardness. Due to a lack of sufficient receiving water information (pH, dissolved organic carbon, and hardness) for calculating criteria, the 2018 NAWQC criteria has not been implemented in this permit. Instead, the MRP includes requirements to monitor effluent for aluminum and receiving water for aluminum, pH, dissolved organic carbon, and hardness in order to have sufficient data to evaluate for aluminum toxicity based on the 2018 NAWQC.

Since the Russian River 303(d) list identifies the Lower Russian River as impaired for aluminum based on the California Division of Drinking Water secondary maximum contaminant level (SMCL) of 200 µg/L, effluent limitations for aluminum have been established in this Order based on the SMCL.

The Permittee sampled its discharge monthly during the discharge season between May 2014 and May 2020. Effluent monitoring results ranged from non-detect to 220 µg/L based on 56 samples. The Permittee also sampled the upstream receiving water monthly during the discharge season between October 2014 and October 2015 with monitoring results ranging from 27 µg/L to 580 µg/L based on 11 samples. Because aluminum levels in the effluent and upstream receiving water have been measured above 200 µg/L, the Regional Water Board concludes that discharges from the Facility have a reasonable potential to cause or contribute to exceedances of applicable water quality criteria for the receiving water for aluminum. In order to protect water quality, an AMEL of 200 µg/L and an MDEL of 606 µg/L for aluminum have been established.

4.3.3.2. **Priority Pollutants**

The SIP establishes procedures to implement water quality criteria from the NTR and CTR and for priority, toxic pollutant objectives established in the Basin Plan. The implementation procedures of the SIP include methods to determine reasonable potential (for pollutants to cause or contribute to excursions above state water quality standards) and to establish numeric effluent limitations, if necessary, for those pollutants showing reasonable potential.

Section 1.3 of the SIP requires the Regional Water Board to use all available, valid, relevant, and representative receiving water and effluent data and information to conduct an RPA. During the term of Order No. R1-2014-0002, priority pollutant sampling was conducted on February 10, 2016 at Monitoring

Location EFF-002. In addition, the Permittee conducted once per discharge season monitoring for copper (effluent only) and twice per discharge season monitoring for bis(2-ethylhexyl) phthalate (effluent only). All of this data was used to conduct the RPA.

Hardness: The CTR and the NTR contain water quality criteria for seven metals that vary as a function of hardness; the lower the hardness, the lower the water quality criteria. The SIP requires water quality criteria be properly adjusted for hardness, using the hardness of the receiving water. The hardness-dependent metal criteria include cadmium, copper, chromium (III), lead, nickel, silver, and zinc. The minimum observed receiving water hardness of 75 mg/L was used to calculate the criteria.

To conduct the RPA, Regional Water Board staff identified the maximum effluent concentration (MEC) and maximum background (B) concentration for each priority, toxic pollutant from effluent and receiving water data provided by the Permittee, and compared this information to the most stringent applicable water quality criterion (C) for each pollutant with applicable water quality criteria from the NTR, CTR, and the Basin Plan. Section 1.3 of the SIP establishes three triggers for a finding of reasonable potential.

Trigger 1. If the MEC is greater than C, there is reasonable potential, and an effluent limitation is required.

Trigger 2. If B is greater than C, and the pollutant is detected in effluent (MEC > ND), there is reasonable potential, and an effluent limitation is required.

Trigger 3. After a review of other available and relevant information, a permit writer may decide that a WQBEL is required. Such additional information may include, but is not limited to: the facility type, the discharge type, solids loading analyses, lack of dilution, history of compliance problems, potential toxic impact of the discharge, fish tissue residue data, water quality and beneficial uses of the receiving water, CWA 303(d) listing for the pollutant, and the presence of endangered or threatened species or their critical habitat.

4.3.3.3. Reasonable Potential Determination

Reasonable potential could not be determined for all pollutants, as there are not applicable water quality criteria for all pollutants. The RPA determined that there is either no reasonable potential or there was insufficient information to conclude affirmative reasonable potential for all of the 126 priority pollutants.

Table F-5 summarizes the RPA for each pollutant that was reported in detectable concentrations in the effluent or the receiving water. The MECs,

most stringent water quality objectives/water quality criteria (WQO/WQCs), and background concentrations (B) used in the RPA are presented, along with the RPA results (Yes or No and which trigger) for each toxic pollutant analyzed. No other pollutants with applicable, numeric water quality criteria from the NTR, CTR, and the Basin Plan were measured above detectable concentrations during the monitoring events conducted by the Permittee. Attachment F-1 to this Order summarizes the RPA for all 126 priority pollutants.

Table F-5. Summary of Reasonable Potential Analysis Results for Priority Pollutants, Ammonia, and Title 22 Pollutants

CTR #	Pollutant	Unit	C or Most Stringent WQO/WQC	MEC or Minimum DL ¹	B or Minimum DL ^{1, 2}	RPA Results ³
1	Antimony	µg/L	6.0	0.36 (DNQ)	0.2 (DNQ)	No
2	Arsenic	µg/L	10	0.95 (DNQ)	1	No
5a	Chromium (III)	µg/L	164	<0.32	1.1 (DNQ)	No
6	Copper	µg/L	18 ³	9.5	1.4	No
7	Lead	µg/L	2.2	<0.08	0.15 (DNQ)	No
8	Mercury	µg/L	0.012 ⁴	<0.06	<0.06	Uo
9	Nickel	µg/L	41	13	4.6	No
13	Zinc	µg/L	94	32	4	No
68	Bis(2-ethylhexyl) Phthalate	µg/L	1.8	<0.83 ⁵	<0.83 ⁵	No
Not Applicable	Aluminum	µg/L	200	220	580	Yes (Trigger 1)
Not Applicable	Barium	µg/L	1,000	47	Not Available	No
Not Applicable	Chloride	µg/L	230,000	23,000	Not Available	No

CTR #	Pollutant	Unit	C or Most Stringent WQO/WQC	MEC or Minimum DL ¹	B or Minimum DL ^{1, 2}	RPA Results ³
Not Applicable	Fluoride	µg/L	2,000	210	Not Available	No
Not Applicable	Specific Conductance	µmhos/cm	900	715	317	No
Not Applicable	Total Dissolved Solids	mg/L	500	440	320	No
Not Applicable	Ammonia	mg/L	0.66 ⁶	<0.2	<0.2	No
Not Applicable	Nitrate (as N)	mg/L	10	8.1	0.77	No
Not Applicable	Nitrite (as N)	mg/L	1.0	0.044	Not Available	No
Not Applicable	Total Nitrogen (as N)	mg/L	10	8.1	Not Available	No

Table Notes:

1. The Maximum Effluent Concentration (MEC) or maximum background concentration (B) is the actual detected concentration unless it is preceded by "<", in which case the value shown is the minimum detection level as the analytical result was reported as not detected (ND).
2. The MEC or B is "Not Available" when there are no monitoring data for a constituent. RPA Results:
= Yes, if MEC > WQO/WQC, or B > WQO/WQC and MEC is detected.
= No, if MEC and B or < WQO/WQC or all effluent data are undetected.
= Undetermined (Uo).
3. Copper WQO calculated with a water effects ratio (WER) of 2.41 and the most stringent WQO from the CTR using the lowest receiving water hardness of 75 mg/L (2.41 x 7.3 µg/L = 18 µg/L).
4. Represents the water column concentration for translation of the fish tissue WQO for protection of the COMM, WILD, and RARE beneficial uses applicable to the Russian River, a flowing waterbody, established in the State Water Board's *Final Part 2 of the Water Quality Control Plan for Inland Surface Waters, Enclosed Bays, and Estuaries of California—Tribal and Subsistence Fishing Beneficial Uses and Mercury Provisions* (Statewide Mercury Objectives).
5. Two of 17 effluent samples were analyzed with an analytical method with a reporting limit of 3.0 µg/L. Since 15 effluent samples analyzed with a reporting limit of 0.83 µg/L were below the most stringent water quality objective, a determination of no reasonable potential has

CTR #	Pollutant	Unit	C or Most Stringent WQO/WQC	MEC or Minimum DL ¹	B or Minimum DL ^{1, 2}	RPA Results ³
<p>been made for bis(2-ethylhexyl)phthalate, as further discussed under the Bis(2-ethylhexyl)phthalate subheading below.</p> <p>6. Ammonia criteria are determined on a sliding scale based upon temperature and pH. The criterion represented in this table is based upon chronic exposure and a temperature of 16.8°C and a pH of 8.5.</p>						

Additional details regarding priority pollutant constituents for which reasonable potential was not found, but warrant further explanation are included in the following paragraphs:

Copper. The CTR includes hardness-dependent criteria for the protection of freshwater aquatic life for copper. The criteria for copper are expressed in dissolved concentrations. U.S. EPA recommends conversion factors to translate dissolved concentrations to total concentrations. The U.S. EPA default conversion factors for copper in freshwater are 0.96 for both the acute and the chronic criteria. The default water effect ratio (WER) used for calculating criteria for copper is 1.0. The Permittee conducted a WER study in 2012 to determine the site-specific toxicity of copper in the receiving water at the point of discharge. The Permittee’s study concluded that a site-specific WER of 2.41 for total recoverable copper applies to the discharge. Using the worst-case measured hardness from the receiving water (75 mg/L), the U.S. EPA recommended dissolved-total translator of 0.96, and the site-specific WER of 2.41, the applicable chronic criterion (maximum 4 day average concentration) is 18 µg/L and the applicable acute criterion (maximum 1-hour average concentration) is 26 µg/L.

During the term of Order No. R1-2014-0002, the Permittee sampled for copper in the effluent nine times and copper in the receiving water twice between October 2014 and March 2020. Copper was detected in the effluent in all eight effluent samples, with results ranging from 5.1 µg/L to 9.5 µg/L. Copper was also detected in the receiving water sample twice between February 2016 and March 2020 with results of 1.1 µg/L (DNQ) and 1.4 µg/L. A determination of no reasonable potential has been made based on the MEC of 9.5 µg/L not exceeding the most stringent water quality objective of 18 µg/L.

Mercury. The State Water Board adopted Resolution 2017-0027 on May 2, 2017, which *approved Part 2 of the Water Quality Control Plan for Inland Surface Waters, Enclosed Bays, and Estuaries of California—Tribal and Subsistence Fishing Beneficial Uses and Mercury Provisions* (Statewide

Mercury Provisions). The Statewide Mercury Provisions establish a Sport Fish Water Quality Objective of an average 0.2 mg/kg methylmercury fish tissue concentration within a calendar year for waters with the beneficial uses of commercial and sport fishing (COMM), tribal tradition and culture (CUL), wildlife habitat (WILD), and marine habitat (MAR). This fish tissue objective corresponds to a water column concentration of 12 ng/L of total mercury for flowing water bodies (e.g., generally, rivers, creeks, streams, and waters with tidal mixing) with COMM, CUL, WILD, MAR, and/or RARE uses. The Statewide Mercury Provisions also established a Tribal Subsistence Fishing (T-SUB) Objective that corresponds to a water column concentration of 4 ng/L of total mercury for flowing water bodies with T-SUB beneficial use. The Russian River is a flowing water body and, as shown in Table F-5, the beneficial uses of the Russian River include COMM, WILD, and RARE. Therefore, the water column concentration of 12 ng/L is appropriate to translate the Sport Fish Water Quality Objective fish tissue objective for the receiving water. The Regional Water Board's current Basin Planning Program Work Plan for Fiscal Years 2018 through 2021 identifies the need to update beneficial use designations and water quality objectives. This would include updating the Basin Plan to include the T-SUB beneficial use for the Russian River.

The Statewide Mercury Provisions specify that the RPA shall be conducted using the maximum annual average effluent and background mercury concentrations for comparison with the Sport Fish Water Quality Objective.

Discharge Point 002. The MEC for mercury was <60 ng/L, with a maximum annual average of <60 ng/L, based on three samples, ranging from 1.2 to <60 ug/L collected at Monitoring Location EFF-002 during the term of Order No. R1-2014-0002. The maximum annual average background concentration for mercury was <60 ng/L based on three ambient samples, ranging from 3.5 to <60 ng/L, collected at RSW-001 during the term of Order No. R1-2014-0002. The most recent effluent and receiving water sample results in March 2020 show mercury concentrations less than the water column concentration limit from the Statewide Mercury Provisions. The samples collected in 2016 utilized reporting limits that are higher than the limits in the Statewide Mercury Provisions. Regional Water Board staff have determined that additional monitoring is necessary to ensure that adequate monitoring data is available to assess reasonable potential for mercury, thus a monthly monitoring frequency has been established.

Bis(2-ethylhexyl)Phthalate. Order No. R1-2014-0002 included effluent limitations for bis(2-ethylhexyl)phthalate. The most stringent water quality objective for bis(2-ethylhexyl)phthalate is 1.8 µg/L. Bis(2-ethylhexyl)phthalate was not detected in any of the 17 effluent samples collected between January

2015 and March 2020. Bis(2-ethylhexyl) phthalate was also not detected in the two receiving water sample collected in February 2016 and March 2020. Two of the 17 effluent samples were analyzed with an analytical method with a reporting limit of 3.0 µg/L, which is not sensitive enough to determine if bis(2-ethylhexyl)phthalate was present above the most stringent water quality objective of 1.8 µg/L, but since bis(2-ethylhexyl)phthalate was not detected in either the 15 effluent or two receiving water samples that were analyzed with sufficiently sensitive methods, a determination of no reasonable potential has been made and effluent limitations have not been retained in this Order.

4.3.4. **WQBEL Calculations**

Final WQBELs have been determined using the methods described in section 1.4 of the SIP.

Step 1: To calculate the effluent limits, an effluent concentration allowance (ECA) is calculated for each pollutant found to have reasonable potential using the following equation, which takes into account dilution and background concentrations:

$$ECA = C + D (C - B),$$

Where:

C = the applicable water quality criterion (adjusted for effluent hardness and expressed as the total recoverable metal, if necessary)

D = dilution credit (here D= 0, as the discharge does not qualify for a dilution credit)

B = background concentration

Here, no credit for dilution is allowed, which results in the ECA being equal to the applicable criterion (ECA = C).

Step 2: For each ECA based on an aquatic life criterion/objective, the long-term average discharge condition (LTA) is determined by multiplying the ECA by a factor (multiplier), which adjusts the ECA to account for effluent variability. The multiplier depends on the coefficient of variation (CV) of the data set and whether it is an acute or chronic criterion/objective. Table 1 of the SIP provides pre-calculated values for the multipliers based on the values of the CV. When the data set contains less than 10 sample results, or when 80 percent or more of the data set is reported as ND, the CV is set equal to 0.6. Derivation of the multipliers is presented in section 1.4 of the SIP.

The reasonable potential analysis described in Fact Sheet section 4.3.3 did not identify the need to calculate effluent limitations for any pollutants with aquatic life criteria, therefore Steps 2 and 3 are included to describe the procedure that would be used in the future if reasonable potential is found for any pollutant(s) with aquatic life criteria.

Step 3: WQBELs, including an AMEL and MDEL, are calculated using the most limiting (lowest) LTA. The LTA is multiplied by a factor that accounts for averaging periods and exceedance frequencies of the effluent limitations, and for the AMEL, the effluent monitoring frequency. The sampling frequency is set equal to 4 ($n = 4$) for the acute criterion and chronic 4-day criterion. The 99th percentile occurrence probability was used to determine the MDEL multiplier and a 95th percentile occurrence probability was used to determine the AMEL multiplier. Since reasonable potential was not found for any pollutants with aquatic life criterion/objectives, no effluent limitations were calculated for this permit.

Step 4: When the most stringent water quality criterion/objective is a human health criterion/objective (aluminum), the AMEL is set equal to the ECA. For a limited data set (less than 10 data points) the coefficient of variation (CV) is set equal to 0.6. From Table 2 of the SIP, when $CV = 1.85$ and $n = 4$, the MDEL multiplier at the 99th percentile occurrence probability equals 8.1, and the AMEL multiplier at the 95th percentile occurrence probability equals 2.7. The MDEL for protection of human health is calculated by multiplying the ECA by the ratio of the MDEL multiplier to the AMEL multiplier. Final WQBELs for aluminum are determined as follows:

Table F-6. Determination of Long-Term Averages

Pollutant	Units	ECA	MDEL/AMEL	MDEL	AMEL
Aluminum	µg/L	200	3.03	606	200

4.3.5. Whole Effluent Toxicity (WET)

Monitoring and effluent limitations for whole effluent toxicity testing protects the receiving water from the aggregate effect of a mixture of pollutants that may be present in the effluent. There are two types of WET tests – acute and chronic. An acute toxicity test is conducted over a short time period and measures mortality. A chronic test is conducted over a longer period of time and may measure mortality, reproduction, and/or growth.

WET requirements are derived from the CWA and the Basin Plan. The Basin Plan establishes a narrative water quality objective for toxicity that states, “All

waters shall be maintained free of toxic substances in concentrations that are toxic to, or that produce detrimental physiological responses in human, plant, or aquatic life.” Detrimental responses may include, but are not limited to, decreased growth rate, decreased reproductive success of resident or indicator species, and/or significant alterations in population, community ecology, or receiving water biota. For compliance with the Basin Plan’s narrative toxicity objective, this Order requires the Permittee to conduct WET testing for acute and chronic toxicity, as specified in the MRP (Attachment E, section 5).

4.3.5.1. **Acute Aquatic Toxicity**

Consistent with Order No. R1-2014-0002, this Order includes an effluent limitation for acute toxicity in accordance with the Basin Plan, which requires that the average survival of test organisms in undiluted effluent for any three consecutive 96-hour bioassay tests be at least 90 percent, with no single test having less than 70 percent survival.

The Order implements federal guidelines (Regions 9 and 10 Guidelines for Implementing Whole Effluent Toxicity Testing Programs) by requiring the Permittee to conduct acute toxicity tests on a fish species and on an invertebrate species to determine the most sensitive species. According to the U.S. EPA manual, *Methods for Estimating the Acute Toxicity of Effluents and Receiving Waters to Freshwater and Marine Organisms* (EPA/600/4-90/-27F), the acceptable vertebrate species for the acute toxicity test are the fathead minnow, *Pimephales promelas* and the rainbow trout, *Oncorhynchus mykiss*. The acceptable invertebrate species for the acute toxicity test are the water flea, *Ceriodaphnia dubia*, *Daphnia magna*, and *D. pulex*. This Order requires the Permittee to conduct a screening test using a vertebrate and invertebrate species. After the screening test is completed, monitoring can be reduced to the most sensitive species. Attachment E of this Order requires annual acute WET monitoring.

During the term of the previous permit, the Permittee monitored for acute toxicity 11 times. Ten samples had 100% survival and one sample had 95% survival, thus met acute toxicity effluent limitations established in Order No. R1-2014-0002. However, this Order retains the acute toxicity effluent limitation in section 4.1.2.2 as a standard permit requirement and annual monitoring during periods of discharge has been retained in recognition of the fact that municipal wastewater effluent may contain pollutants that could result in acute toxicity, thus continued data collection is needed to assess reasonable potential during this permit term.

4.3.5.2. **Chronic Aquatic Toxicity**

The SIP requires the use of short-term chronic toxicity tests to determine compliance with the narrative toxicity objectives for aquatic life in the Basin Plan. The SIP requires that the Permittee demonstrate the presence or absence of chronic toxicity using tests on the fathead minnow, *Pimephales promelas*, the water flea, *Ceriodaphnia dubia*, and the freshwater alga, *Selenastrum capricornutum* (also named *Raphidocelis subcapitata*). Attachment E of this Order requires annual chronic WET monitoring to demonstrate compliance with the narrative toxicity objective.

The Permittee conducted chronic toxicity testing using *P. promelas*. The following table summarizes the chronic toxicity testing results from the term of Order No. R1-2014-0002.

Table F-7. Summary of Chronic Toxicity Results (TUc)

Date	<i>P. promelas</i> Survival	<i>P. promelas</i> Growth	<i>C.dubia</i> Survival	<i>C.dubia</i> Reproduction	<i>S. capricornutum</i> Growth
January 19, 2015	1	1	--	--	--
February 8, 2016	1	1	--	--	--
February 13, 2017	1	1	--	--	--
January 15, 2018	1	1	--	--	--
February 4, 2019	1	1	--	--	--
February 24, 2020	1	1	1	1	1
March 16, 2020	1	1	1	1	1

The Permittee’s chronic toxicity tests all demonstrated no toxicity; therefore, the Regional Water Board concludes that the discharge does not have reasonable potential to cause or contribute to an exceedance of the Basin Plan’s narrative toxicity objective, and this Order does not establish a narrative effluent limitation for chronic toxicity.

This Order includes a reopener that allows the Regional Water Board to reopen the Order and include a numeric chronic toxicity limitation, a revised acute toxicity limitation, and/or a limitation for a specific toxicant identified in the TRE.

To ensure compliance with the Basin Plan’s narrative toxicity objective, the Permittee is required to conduct annual chronic WET testing at Discharge Point 002, as specified in the MRP (Attachment E, section 5.2). Furthermore, the MRP (Attachment E, section 5.3) requires the Permittee to investigate the

causes of, and identify and implement corrective actions to, reduce or eliminate effluent toxicity. If the discharge demonstrates toxicity with a result of “Fail” in 100 percent effluent, the Permittee is required to initiate a TRE in accordance with an approved TRE Work Plan. The “Pass/Fail” trigger is not an effluent limitation; it is the toxicity threshold at which the Permittee is required to perform accelerated chronic toxicity monitoring, as well as the threshold to initiate a TRE if a pattern of effluent toxicity has been demonstrated.

4.3.5.3. **Test of Significant Toxicity**

Order No. R1-2014-0002 established a numeric chronic toxicity trigger of 1.0 TUc = 100/NOEC, using a five-concentration hypothesis test. In 2010, U.S. EPA endorsed the peer-reviewed *Test of Significant Toxicity (TST) two-concentration hypothesis testing approach in National Pollutant Discharge Elimination System Test of Significant Toxicity Implementation Document* (EPA 833-R-10-003, 2010) as an improved hypothesis-testing tool to evaluate data from U.S. EPA’s toxicity test methods. The TST hypothesis testing approach more reliably identifies toxicity—in relation to the chronic (0.25 or more) mean response of regulatory management concern—than the No Observed Effect Concentration (NOEC) hypothesis-testing approach. The TST hypothesis testing approach more reliably identifies toxicity – in relation to the acute (0.20 or more) mean responses of regulatory management concern – than the NOEC approach used previously to establish effluent limitations for acute toxicity.

Since the TST approach has not previously been applied for determining reasonable potential or establishing effluent limitations for acute toxicity, this Order does not include effluent limitations for acute or chronic toxicity based on the TST approach. However, this Order requires the Permittee to monitor and report results in a manner that will allow the Regional Water Board to conduct an RPA in accordance with the TST approach at the time of the next permit renewal.

On December 1, 2020, the State Water Board adopted a toxicity amendment to the *Water Quality Control Plan for Inland Surface Waters, Enclosed Bays, and Estuaries of California* (Toxicity Provisions) that standardizes the regulation of aquatic toxicity for all non-oceanic surface waters. U.S. EPA’s TST approach is an essential component of this adopted toxicity amendment as it forms the basis for utilizing numeric water quality objectives and acts as the primary means of determining compliance with the proposed effluent limitations. At the time this permit is being developed, the Toxicity Provisions are awaiting approval from the U.S. EPA. The permit may be modified, if necessary, to incorporate new statewide toxicity criteria established by the Toxicity Provisions.

In a letter dated February 12, 2014, the State Water Board submitted an alternative test process (ATP) request to U.S. EPA Region 9 for the statewide use of a two-concentration toxicity test design when using the TST approach. This two-concentration test design is composed of a single effluent concentration and a control concentration. U.S. EPA approved the ATP request on March 17, 2014. In June 2014, the approval was challenged in court on procedural grounds under the Administrative Procedures Act by the Southern California Alliance of Publicly Owned Treatment Works (SCAP) and the Central Valley Clean Water Association (CVCWA).

The U.S. EPA withdrew the approval and notified the State Water Board in a memo dated February 11, 2015. In a letter dated November 25, 2020, the State Water Board submitted a new ATP request to U.S. EPA Region 9. At the time this permit is being developed, the State Water Board is awaiting a response from U.S. EPA.

It is important to note that U.S. EPA's rescission of its approval of the ATP is not based on the substantive TST statistical analysis or the scientific validity of a two-concentration test design. The withdrawal letter also states that currently there is a proposed rulemaking to change the language in the ATP regulations at 40 C.F.R. part 136.

The benefits of requiring the TST in new or amended permits include improving the statistical power of the toxicity test and simplifying the analysis as compared to the traditional hypothesis statistical approaches or point estimates. The calculations are straightforward and provide a clear pass/fail result. With the withdrawal of the two-concentration test design approval, an NPDES permit can still require the TST for statistical analyses. Toxicity tests shall be run using a multi-concentration test design in accordance with 40 C.F.R. section 136.3, and the TST shall be utilized with the biological responses from the permitted in-stream waste concentration (IWC) and the control (effluent concentration of zero). However, even with only two of the five concentration biological responses being used, cost savings in the form of time and effort are still realized for the statistical analysis and data interpretation carried out by the Permittee, lab, and permit manager. This Order requires application of the TST for statistical analysis of whole effluent toxicity data.

Test of Significant Toxicity Design

The TST's null hypothesis for chronic toxicity is:

H_0 : Mean response (In-stream Waste Concentration (IWC) in % effluent) \leq 0.75 mean response (control)

Results are analyzed using the TST approach and an acceptable level of chronic toxicity is demonstrated by rejecting the null hypothesis and reporting “Pass” or “P”.

The chronic IWC (in % effluent) for Discharge Point 001 is 100%. The chronic toxicity trigger for Discharge Point 001 is expressed as a null hypothesis (H_0) and regulatory management decision (b value) of 0.75 for the chronic toxicity methods in the MRP. The null hypothesis for this discharge is:

H_0 : Mean response (100% effluent) \leq 0.75 mean response (control)

Results shall be analyzed using the TST hypothesis testing approach in section 5.2.6.1 of the MRP. Compliance with this chronic toxicity limitation is demonstrated by rejecting the null hypothesis and reporting “Pass” or “P”.

When the chronic toxicity test results in a “Fail” or “F,” the Permittee must initiate accelerated monitoring as specified in the MRP (Attachment E, section 5). After accelerated monitoring, if conditions of chronic toxicity are found to persist, the Permittee will be required to conduct a TRE, as described by the MRP.

Notification requirements for chronic WET testing include a 72-hour verbal notification requirement and a 14-day written report requirement, if test results indicate toxicity. The 14-day written notification is established in the U.S. EPA WET Guidance documents cited in the MRP. The 72-hour verbal notification requirement is being added to provide the Regional Water Board with knowledge of the toxicity in advance of the written report. The 72-hour requirement is intended to give the Permittee sufficient time to make a telephone call to Regional Water Board staff and accounts for non-working days (e.g., weekends). Verbal notification of WET test exceedances may be left by voice mail if the Regional Water Board staff person is not immediately available by telephone.

This Order includes a requirement for the Permittee to conduct a screening test using at least one vertebrate, invertebrate, and plant species. After the screening test is completed, monitoring can be reduced to the most sensitive species.

Chronic WET limitations will be established if future monitoring results demonstrate that discharges from the Facility are causing or contributing to chronic toxicity in the receiving water.

4.4. Final Effluent Limitation Considerations

4.4.1. Anti-Backsliding Requirements

Sections 402(o) and 303(d)(4) of the CWA and federal regulations at 40 C.F.R. section 122.44(l) prohibit backsliding in NPDES permits. These anti-backsliding provisions require effluent limitations in a reissued permit to be as stringent as those in the previous permit, with some exceptions where limitations may be relaxed. All effluent limitations in this Order are at least as stringent as the effluent limitations in Order No. R1-2014-0002, with the exception of mass-based effluent limitations for BOD₅ and TSS at Discharge Point 001 and effluent limitations for ammonia nitrate, and bis(2-ethylhexyl)phthalate, at Discharge Point 002.

Order No. R1-2014-0002 established final mass-based effluent limitations for BOD₅ and TSS at Discharge Point 001. Historically, the Regional Water Board routinely incorporated mass-based limits (in addition to concentration-based limits) for BOD₅ and TSS in NPDES permits to encourage correction of inflow and infiltration (I&I). Applied in this way, mass-based limitations effectively restrict a POTW's wet weather influent flows to less than or equal to the Facility's design capacity in situations where POTWs experience excessive I&I as a result of climate conditions and/or aging infrastructure. The application of mass-based effluent limitations for BOD₅ and TSS is not necessary to limit wet weather inflow to the Facility because the Order includes flow limitations (Discharge Prohibition 3.8) that require the Permittee to control effluent flow to stay below the design capacity of the Facility and further requires the Permittee to implement flood control and flow reduction mitigation measures (Order section 6.3.6.2) in order to limit I&I impacts. The Permittee has recognized sources of I&I and is in the process of improving its collection system in order to limit I&I impacts. The Permittee has a plan to address I&I through the replacement and/or repair of deficiencies found during video inspections, smoke testing, line cleaning, and education of facilities that use temporary connections (e.g., campgrounds, trailer parks) to shut off connection points during flood events. The Permittee is also implementing a project to assess the condition of the headworks and lift stations to identify improvements to keep the headworks and lift stations operating through their remaining service life and prioritize necessary rehabilitation or replacement.

Mass limitations for BOD₅ and TSS for discharges of treated wastewater have been removed because Regional Water Board staff misinterpreted the exception of 40 C.F.R. section 122.45(f)(2), which states that mass limitations are not required "*when applicable standards and limitations are expressed in terms of other units of measure.*" Secondary treatment standards for BOD₅ and TSS in 40 C.F.R. section 133.102, on which the effluent limitations in previous permits were based, are expressed in terms of concentration and percent

removal (i.e., other units of measure). The relaxation of effluent limitations for BOD₅ and TSS in this Order is permissible under CWA section 402(o)(2)(B)(ii), because Regional Water Board staff has determined that mass-based limitations for BOD₅ and TSS were applied in the previous permits as a result of a mistaken interpretation of law when issuing those previous permits.

In addition, Regional Water Board staff previously held that anti-backsliding regulations prevented the removal of mass-based limitations for BOD₅ and TSS because they were appropriate and necessary to protect water quality and prevent water quality degradation in receiving waters. While it is conceivable that the absence of mass-based limitations for these pollutants may result in an increased pollutant loading to surface waters, recent self-monitoring reports indicate that compliance with concentration-based effluent limitations for BOD₅ and TSS effectively maintain the Permittee's mass emission rates for BOD₅ and TSS well below permitted mass-based limitations. In addition, even if there is a resulting increase in pollutant loading, there is no evidence that the increase will result in degradation of water quality. Therefore, relaxation of effluent limitations for BOD₅ and TSS in this Order is also permissible under CWA section 402(o)(2)(B)(i), based on new information available to the Regional Water Board.

Order No. R1-2014-0002 established final effluent limitations for ammonia, nitrate, and bis(2-ethylhexyl)phthalate. As shown in Table F-5 of this Fact Sheet, effluent data demonstrate that the discharge no longer demonstrates reasonable potential to cause or contribute to an exceedance of these water quality objectives. The updated effluent data for ammonia, nitrate, and bis(2-ethylhexyl) phthalate, constitutes new information, which permits the removal of effluent limitations consistent with CWA section 402(o)(2)(B). Therefore, the Order does not retain the effluent limitations for ammonia, nitrate, and bis(2-ethylhexyl) phthalate.

4.4.2. **Antidegradation Policies**

State Water Board Resolution 68-16, the *Statement of Policy with Respect to Maintaining High Quality Waters in California* (the Antidegradation Policy) requires that disposal of waste into waters of the state be regulated to achieve the highest water quality consistent with the maximum benefit to the people of the state. The quality of some waters is higher than established by adopted policies and that higher quality water shall be maintained to the maximum extent possible consistent with the Antidegradation Policy. The Antidegradation Policy requires that (1) higher quality water will be maintained until it has been demonstrated to the state that any change will be consistent with the maximum benefit to the people of the state, will not unreasonably affect present and anticipated beneficial use of the water, and will not result in water quality less than that prescribed in the policies; and (2) any activity that produces a waste or

may produce waste or increased volume or concentration of waste and discharges to existing high quality water will be required to meet waste discharge requirements that will result in the best practicable treatment or control (BPTC) of the discharge necessary to assure pollution or nuisance will not occur, and the highest water quality consistent with the maximum benefit to the people of the state will be maintained.

Discharges from the Facility are required to maintain protection of the beneficial uses of the receiving water and comply with applicable provisions of the Basin Plan.

This Order is consistent with applicable federal and state antidegradation policies, as it does not authorize the discharge of increased concentrations of pollutants or increased volumes of treated wastewater beyond that which was permitted to discharge in accordance with Order No. R1-2014-0002.

4.4.3. **Stringency of Requirements for Individual Pollutants**

This Order contains both technology-based effluent limitations and WQBELs for individual pollutants. The technology-based effluent limitations consist of restrictions on BOD₅, pH, TSS, and total coliform bacteria. Restrictions on these pollutants are discussed in section 4.2 of this Fact Sheet. This Order's technology-based pollutant restrictions implement the minimum, applicable federal technology-based requirements. In addition, this Order contains effluent limitations for pH, and aluminum, that are more stringent than the minimum, federal technology-based requirements but are necessary to meet water quality standards. These requirements are discussed in section 4.3.3 of the Fact Sheet.

WQBELs have been derived to implement water quality objectives that protect beneficial uses. Both the beneficial uses and the water quality objectives have been approved pursuant to federal law and are the applicable federal water quality standards. Most beneficial uses and water quality objectives contained in the Basin Plan were approved under state law and submitted to and approved by U.S. EPA prior to May 30, 2000. Any water quality objectives and beneficial uses submitted to U.S. EPA prior to May 30, 2000, but not approved by U.S. EPA before that date, are nonetheless "*applicable water quality standards for purposes of the CWA*" pursuant to 40 C.F.R. section 131.21(c)(1). Collectively, this Order's restrictions on individual pollutants are no more stringent than required to implement the requirements of the CWA.

The Regional Water Board has considered the factors in Water Code section 13263, including the provisions of Water Code section 13241, in establishing these requirements.

4.5. **Interim Effluent Limitations – Not Applicable**

This Order does not establish interim effluent limitations or schedules for compliance with final limitations.

4.6. **Land Discharge Specifications**

4.6.1. **Scope and Authority**

Section 13263 of the Water Code requires the Regional Water Board to prescribe requirements for proposed discharges, existing discharges, or material changes in an existing discharge based upon the conditions of the disposal area or receiving waters upon or into which the discharge is made or proposed. The prescribed requirements shall implement any relevant water quality control plans that have been adopted, and shall take into consideration the beneficial uses to be protected, the water quality objectives reasonably required for that purpose, other waste discharges, the need to prevent nuisance, and the provisions of Water Code section 13241. In prescribing requirements, the Regional Water Board is not obligated to authorize the full waste assimilation capacities of the receiving water.

Water Code section 13241 requires the Regional Water Board to establish water quality objectives in water quality control plans as in its judgment will ensure the reasonable protection of beneficial uses and prevention of nuisance, recognizing that it may be possible for the quality of water to be changed to some degree without unreasonably affecting beneficial uses. The Basin Plan establishes water quality objectives specific to the North Coast Region for the protection of past, present, and probable future beneficial uses of water. Factors required for consideration during development of applicable water quality objectives, such as the characteristics of the hydrographic unit under consideration, economic considerations, and other factors required in accordance with section 13241 were considered during the Basin Planning and adoption process.

Here, the Regional Water Board considered all of these factors when developing the WDRs for the land discharge to the Burch property at Discharge Point 003. Limitations for pH, nitrate, total dissolved solids, sodium, and aluminum were scientifically derived to implement water quality objectives that protect beneficial uses. Both beneficial uses and the water quality objectives have been approved pursuant to state law. In addition, discharge prohibitions were included to prohibit the use of untreated or partially treated wastewater for recycling.

The Regional Water Board considered the factors set forth in Water Code section 13241, including the consideration of past, present, and probable future

beneficial uses of the receiving water, which the Regional Water Board anticipates to be the same as set forth in the Basin Plan. The Regional Water Board considered the environmental characteristics, including water quality of the Lower Russian River Hydrologic Area, the water bearing capacity of groundwater basins in the vicinity of the discharge, the coordinated control of all factors which affect water quality in the area, and the need to maintain a land discharge. The Permittee did not submit any evidence regarding whether the WDRs for discharges to land would interfere with the development of needed housing within the region or the costs of compliance, particularly anything to show that the costs of compliance with the Order would be unmanageable.

4.6.2. **Applicable Beneficial Uses and Water Quality Criteria and Objectives**

4.6.2.1. **Beneficial Uses.** Beneficial use designations for groundwater established in the Basin Plan include municipal and domestic supply (MUN), industrial service supply (IND), industrial process supply (PRO), agricultural supply (AG), native American culture (CUL), and aquaculture (AQUA).

4.6.2.2. **Basin Plan Water Quality Objectives.** The Basin Plan contains narrative objectives for taste and odor, bacteria, radioactivity, and chemical constituents (including those chemicals that adversely affect agricultural water supply) that apply to groundwater.

4.6.3. **Determining the Need for Requirements for Discharges to Land**

Section 4.2 of this Order contains Land Discharge Specifications and Requirements to ensure that the effluent produced and used by this Facility meets minimum requirements for the protection of groundwater and surface water.

4.6.3.1. Section 4.2.1 includes the following land discharge specifications that apply to land discharges to the Burch property at Discharge Point 003:

4.6.3.1.1. **pH.** Consistent with Order No. R1-2014-0002, this Order includes instantaneous minimum and maximum effluent limitations for pH of 6.0 and 9.0, respectively, based on the technology-based effluent limitations required by U.S. EPA pursuant to 40 C.F.R. part 133. These pH limitations are included in the Order to ensure that pH levels are appropriate for the protection of groundwater when discharging to land.

4.6.3.1.2. **Nitrate.** Consistent with Order No. R1-2014-0002, this Order includes average monthly and maximum daily effluent limitations for nitrate of 10 mg/L and 20 mg/L, respectively, based on the Primary MCL established by DDW for the protection of public water supplies at title 22 of the CCR, sections 64431 (Inorganic Chemicals) and 64444 (Organic Chemicals).

- 4.6.3.1.3. **Aluminum.** Consistent with Order No. R1-2014-0002, this Order includes an effluent limitation for aluminum of 1 mg/L, based on the Primary MCL established by DDW for the protection of public water supplies at title 22 of the CCR, sections 64431 (Inorganic Chemicals) and 64444 (Organic Chemicals).
- 4.6.3.1.4. **Sodium.** Consistent with Order No. R1-2014-0002, this Order includes an effluent limitation for sodium of 60 mg/L, based on the U.S. EPA Drinking Water Advisory Taste and Odor Threshold.
- 4.6.3.2. Section 4.2.2 includes land discharge requirements that also apply to land discharges to the Burch property at Discharge Point 003. as follows:
- 4.6.3.2.1. **Land Discharge Management. (Land Discharge Requirement 4.2.2.1).** At the Permittee's request, this requirement has been combined with the Recycled Water Management Plan requirement in section 6.3.2.1.1 of this Order to provide a comprehensive report that address land discharge and recycled water management practices. See Fact Sheet section 6.3.2.1.
- 4.6.3.2.2. Land Discharge Requirements 4.2.2.2 through 4.2.2.11 are necessary to ensure protection of surface and groundwater quality.
- 4.6.4. **Land Discharge Reporting.** Section 10.4.2.11 of the MRP requires submittal of an Annual Land Discharge and Management Plan Report to document compliance of the land discharge system with requirements in this Order and identification of corrective actions in the event that deficiencies are identified.

4.7. **Water Recycling Specifications and Requirements**

The Permittee has a recycled water system to irrigate the Northwood Golf Course consistent with agronomic demand. Irrigation occurs from May 15 through September 30 and other times during the year when weather allows (e.g., dry fall, winter, and spring periods). All of the water recycling specifications are based on the technical capabilities of the wastewater treatment system and levels required by the Basin Plan and title 22.

4.7.1. **Scope and Authority**

Section 13263 of the Water Code requires the Regional Water Board to prescribe requirements for proposed discharges, existing discharges, or material changes in an existing discharge based upon the conditions of the disposal area or receiving waters upon or into which the discharge is made or proposed. The prescribed requirements shall implement any relevant water quality control plans that have been adopted and shall take into consideration the beneficial uses to be protected, the water quality objectives reasonably

required for that purpose, other waste discharges, the need to prevent nuisance, and the provisions of Water Code section 13241. In prescribing requirements, the Regional Water Board is not obligated to authorize the full waste assimilation capacities of the receiving water.

Water Code section 13241 requires the Regional Water Board to establish water quality objectives in water quality control plans as in its judgment will ensure the reasonable protection of beneficial uses and prevention of nuisance, recognizing that it may be possible for the quality of water to be changed to some degree without unreasonably affecting beneficial uses. The Basin Plan establishes water quality objectives specific to the North Coast Region for the protection of past, present, and probable future beneficial uses of water. Factors required for consideration during development of applicable water quality objectives, such as the characteristics of the hydrographic unit under consideration, economic considerations, and other factors required in accordance with section 13241 were considered during the Basin Planning and adoption process.

Here, the Regional Water Board considered all of these factors when developing the water recycling specifications for the recycled water discharge to the Northwood Golf Course at Discharge Point 004. Limitations for BOD₅, pH, TSS, nitrate and total coliform were derived based upon the treatment capability of the Facility and levels required by the Basin Plan and title 22 in order to implement water quality objectives that protect the beneficial uses of both surface and groundwater. Both beneficial uses and the water quality objectives have been approved pursuant to state law, and then submitted to and approved by U.S. EPA. In addition, discharge prohibitions were included to prohibit the use of untreated or partially treated wastewater for recycling.

The Regional Water Board considered the factors set forth in Water Code section 13241, including the consideration of past, present, and probable future beneficial uses of the receiving water, which the Regional Water Board anticipates to be the same as set forth in the Basin Plan. The Regional Water Board considered the environmental characteristics, including water quality of the Lower Russian River Hydrologic Area, the coordinated control of all factors that affect water quality in the area, and the need to develop and use recycled water, which this Order supports.

4.7.2. Applicable Beneficial Uses and Water Quality Criteria and Objectives

- 4.7.2.1. **Beneficial Uses.** Beneficial use designations for groundwater established in the Basin Plan include existing uses: MUN, AGR, IND, and CUL and potential uses: AQUA and PRO.

4.7.2.2. **Basin Plan Water Quality Objectives.** The Basin Plan contains narrative objectives for taste and odor, bacteria, radioactivity, and chemical constituents (including those chemicals that adversely affect agricultural water supply) that apply to groundwater.

4.7.3. **Determining the Need for Requirements for Water Recycling**

Section 4.3 of this Order contains Water Recycling Specifications and Requirements to ensure that the recycled water produced and used by this Facility meets minimum requirements for the protection of groundwater and surface water. The Water Recycling Specifications are established in this Order to conform to requirements contained in title 22, division 4, chapter 3 of the CCR for the recycling use of disinfected tertiary-2.2 recycled water. The Permittee is required to comply with applicable state and local requirements regarding the production and use of recycled wastewater, including requirements of Water Code sections 13500 – 13577 (Water Reuse) and DDW regulations at title 22, sections 60301 – 60357 of the CCR (Water Recycling Criteria). Specific water recycling requirements are enumerated in Attachment G to this Order. The requirement to comply with title 22 requirements is retained from Order No. R1-2014-0002.

4.7.3.1. **Coliform Bacteria.** Consistent with Order No. R1-2014-0002, this Order includes recycled water specifications for total coliform bacteria that reflect standards for tertiary treated recycled water adopted by DDW in title 22 of the CCR and are included to ensure that recycled water quality is protective of human health. Recycled water from this Facility will meet the highest title 22 treatment and disinfection standards and will be suitable for the broad range of recycled water uses identified in title 22, including irrigation of urban landscapes and crops produced for human consumption.

4.7.3.2. **Nitrate.** Consistent with Order No. R1-2014-0002, this Order includes average monthly and maximum daily effluent limitations for nitrate of 10 mg/L and 20 mg/L, respectively, based on the Primary MCL established by DDW for the protection of public water supplies at title 22 of the CCR, sections 64431 (Inorganic Chemicals) and 64444 (Organic Chemicals).

4.7.3.3. **Title 22 Engineering Report.** This Order requires the Permittee to implement a DDW-approved title 22 Engineering Report that demonstrates compliance with Statewide Water Recycling Criteria in title 22, division 4, chapter 3 of the CCR. The Permittee's most recent title 22 engineering report was accepted by DDW by letter dated January 22, 2021.

4.7.3.4. **Water Recycling Requirements and Provisions – Attachment G.** The water recycling requirements of this Order (including Attachment G) are consistent with the requirements of title 22 of the CCR, the State Water Board

Recycled Water Policy, and State Water Board Order WQ 2016-0068-DDW, *Water Reclamation Requirements for Recycled Water Use*, adopted by the State Water Board on June 7, 2016. Attachment G of this Order contains Recycled Water Findings, Requirements and Provisions to ensure that recycled water is used in a manner that is protective of groundwater and surface water quality.

A key to reducing the potential for spills is for the Permittee to establish appropriate BMPs to protect against the possibility of recycled water spills. Section 6.3.2.1 of the Order requires the Permittee to update and implement BMPs for the management of the recycled water system. When implemented properly, BMPs employed by the Permittee will reduce the potential and severity of recycled water spills and runoff.

4.8. Other Requirements.

This Order contains additional specifications that apply to the Facility regardless of the disposal method (surface water discharge, land disposal, or recycling), including:

- 4.8.1. **Filtration Rate.** Consistent with Order No. R1-2014-0002, section 4.4.1.1 of the Order includes a filtration loading rate which has been modified at the recommendation of DDW in their January 22, 2021 Title 22 Engineering Report Conditional Acceptance letter. The Order requires that wastewater be filtered at a rate that does not exceed 6 gallons per minute per square foot of filter surface area. The prior filtration surface loading rate was based on the definition of filtered wastewater found in title 22 section 60301.320 of the CCR. The revised rate is based on conditions specified in Department of Health Service's (now DDW) May 6, 2002 (Corrected Copy – January 13, 2009) letter to Aqua-Aerobic Systems with subject line: *Use of the Aqua-Aerobic Cloth-media Disk Filter to comply with California Water Recycling Criteria*. The title 22 definition, as modified by May 6, 2002 (Corrected Copy – January 13, 2009) letter, is used as a reasonable performance standard to demonstrate that tertiary treated wastewater has been coagulated and adequately filtered for removal of pathogens and for conditioning of water prior to the disinfection process.
- 4.8.2. **Filter Influent Turbidity.** This Order includes a new requirement for influent turbidity to the tertiary wastewater treatment filtration system to meet the specifications identified in section 4.4.1.2 of the Order. These influent filter turbidity specifications are based on DHS May 6, 2002 letter identified in section 4.8.1, immediately above.
- 4.8.3. **Filter Effluent Turbidity.** Consistent with Order No. R1-2014-0002, section 4.4.1.3 of this Order specifies that the turbidity of the filtered wastewater not exceed an average of 2 NTU during any 24 hour period; 5 NTU more than 5

percent of the time within a 24 hour period, and 10 NTU at any time, and is based on the definition of filtered wastewater found in title 22 section 60301.320 of the CCR. The title 22 definition is used as a reasonable performance standard to ensure adequate removal of turbidity upstream of the disinfection facilities. Properly designed and operated effluent filters will meet this standard. The point of compliance for the turbidity requirements is a point following the tertiary wastewater treatment process and before discharge to the disinfection system. The Permittee plans to use chemical addition to supplement filtration if limitations for turbidity cannot be achieved through filtration alone.

- 4.8.4. **Disinfection Process Requirements for the UV Disinfection System.** The Order contains monitoring requirements for the UV disinfection system in section 4.4.2. These requirements are needed to determine compliance with requirements for recycled wastewater systems, established at CCR title 22, division 4, chapter 3 and to ensure that the disinfection process achieves effective pathogen reduction.

UV system operation requirements are necessary to ensure that adequate UV dosage is applied to the wastewater to inactivate pathogens (e.g., viruses, bacteria) in the wastewater. UV dosage is dependent on several factors such as UV transmittance, UV power setting, and wastewater flow through the UV system. Minimum dosage requirements are based on recommendations by DDW and guidelines established by the National Water Research Institute (NWRI) and American Water Works Association Research (AWWARF) "*Ultraviolet Disinfection Guidelines for Drinking Water and Water Reuse*" first published in December 2000 revised as a Third Edition dated August 2012. Furthermore, a Memorandum dated November 1, 2004, issued by DDW to Regional Water Board Executive Officers recommended that provisions be included in permits for water recycling treatment plants employing UV disinfection requiring permittees to establish fixed cleaning frequency of quartz sleeves as well as include provisions that specify minimum delivered UV dose that must be maintained (as recommended by the NWRI/AWWARF UV Disinfection Guidelines). Minimum UV dosage requirements specified in section 4.4.2 of the Order ensures that adequate disinfection of wastewater will be achieved.

- 4.8.5. **Storage Ponds.** Storage pond requirements are included in section 4.4.3 of the Order to ensure that future storage ponds are constructed in a manner that protects groundwater and complies with requirements of title 27 of the CCR.

5. RATIONALE FOR RECEIVING WATER LIMITATIONS

5.1. Surface Water

CWA section 303(a-c) requires states to adopt water quality standards, including criteria, where they are necessary to protect beneficial uses. The Regional Water Board adopted water quality criteria as water quality objectives in the Basin Plan.

The Basin Plan states that “[t]he numerical and narrative water quality objectives define the least stringent standards that the Regional [Water] Board will apply to regional waters in order to protect the beneficial uses.” The Basin Plan includes numeric and narrative water quality objectives for various beneficial uses and water bodies. This Order contains Receiving Surface Water Limitations based on the Basin Plan numerical and narrative water quality objectives for biostimulatory substances, bacteria, chemical constituents, color, dissolved oxygen, floating material, oil and grease, pH, pesticides, radioactivity, sediment, settleable material, specific conductance, suspended material, tastes and odors, temperature, total dissolved solids, toxicity, and turbidity.

The dissolved oxygen limitation in this Order reflects the new Basin Plan dissolved oxygen limitation that was adopted by the Regional Water Board on June 18, 2015, and effective beginning April 24, 2017, after receiving approval from U.S. EPA. The new Basin Plan dissolved oxygen limitation specifies limits for the WARM, COLD, and SPWN beneficial uses. The WARM, COLD, and SPWN beneficial uses occur in the Russian River and its tributaries. This Order includes only the SPWN limitations because it is the most restrictive and protective limit and the SPWN beneficial use is present throughout the entire discharge season. The dissolved oxygen receiving water limitation provides for consideration of a modified limit for waterbodies for which the aquatic life-based dissolved oxygen requirements are unachievable due to natural conditions. The intent of this language is to provide a means to adjust the dissolved oxygen limit to a concentration less than the 9.0 mg/L daily limit and 11.0 mg/L 7-day moving average limit established in section 5.1.1 of the Order and not to increase the limits.

The receiving water limitation for bacteria in section 5.1.20 of the Order reflects the new bacteria water quality objectives applicable to the REC-1 beneficial use adopted by the State Water Board on February 4, 2019 in Part 3 of the *Water Quality Control Plan for Inland Surface Waters, Enclosed Bays, and Estuaries of California – Bacteria Provisions and a Water Quality Standards Variance Policy*.

5.2. Groundwater

Groundwater limitations in this Order have been retained from the previous Order with minor modification to reflect revised sections of title 22. In addition,

monitoring frequencies have been reduced due to the fact that monitoring conducted during the term of the previous Order demonstrates that since completion of the biological nutrient removal project, effluent concentrations of nitrate have been decreased significantly and concentrations of TDS and other salts have also decreased. These decreases in effluent concentrations have resulted in a corresponding decrease in nitrate, TDS, sodium, and chloride in the downgradient monitoring wells. Since the fall of 2014, all effluent and groundwater results have been below the applicable drinking water MCLs/SMCLs for nitrate, TDS, sodium, and chloride. Therefore, groundwater monitoring frequency has been reduced from monthly to semi-annual for the upgradient well, and from monthly to quarterly for the two downgradient wells. Groundwater monitoring must continue to be required to demonstrate that the pattern of improvement in groundwater will be maintained.

Groundwater limitations are included in the Order to protect the beneficial uses of the underlying groundwater. The beneficial uses of the underlying groundwater are municipal and domestic supply, industrial service supply, industrial process supply, agricultural supply, native American culture, and aquaculture. Discharges from the Facility shall not cause exceedance of applicable water quality objectives or create adverse impacts to beneficial uses of groundwater. Groundwater data must be evaluated using appropriate statistical tools to determine when groundwater degradation is occurring.

The decreases in pollutant concentrations in groundwater noted above are directly related to the improvements in effluent quality that has resulted in nitrate concentrations. Therefore, the Permittee must continue to operate the BNR system as efficiently as it has during the previous permit term to ensure that this high effluent quality continues to be maintained to ensure protection of surface and groundwaters. The MRP allows for potential future decreases in groundwater monitoring frequency if effluent and groundwater monitoring continue to demonstrate these improvements in water quality and future increases in monitoring frequency in the event that effluent and/or groundwater quality is degrading.

The Order includes a new groundwater toxicity limitation that was adopted by the Regional Water Board on June 18, 2015, and effective beginning July 18, 2016, after receiving approval from the California Office of Administrative Law. This new Basin Plan limit requires that groundwaters shall not contain toxic substances in concentrations that are toxic to, or that produce detrimental physiological responses in humans, or that adversely affects beneficial uses. This limitation applies regardless of whether the toxicity is caused by a single substance or the synergistic effect of multiple substances.

6. RATIONALE FOR PROVISIONS

6.1. Standard Provisions

6.1.1. Federal Standard Provisions

Standard Provisions, which apply to all NPDES permits in accordance with 40 C.F.R. section 122.41, and additional conditions applicable to specified categories of permits in accordance with 40 C.F.R. section 122.42, are provided in Attachment D to the Order. The Permittee must comply with all standard provisions and with those additional conditions that are applicable under 40 C.F.R. section 122.42. The rationale for the special conditions contained in the Order is provided in section 6.3, below.

Sections 122.41(a)(1) and (b) through (n) of 40 C.F.R. establish conditions that apply to all state issued NPDES permits. These conditions must be incorporated into the permits either expressly or by reference. If incorporated by reference, a specific citation to the regulations must be included in the Order. Section 123.25(a)(12) allows the state to omit or modify conditions to impose more stringent requirements. In accordance with 40 C.F.R. section 123.25, this Order omits federal conditions that address enforcement authority specified in 40 C.F.R. sections 122.41(j)(5) and (k)(2) because the enforcement authority under the Water Code is more stringent. In lieu of these conditions, this Order incorporates by reference Water Code section 13387(e).

6.1.2. Regional Water Board Standard Provisions

In addition to the Federal Standard Provisions (Attachment D), the Permittee shall comply with the Regional Water Board Standard Provisions provided in Standard Provisions 6.1.2 of the Order.

- 6.1.2.1. Order Provision 6.1.2.1 identifies the state's enforcement authority under the Water Code, which is more stringent than the enforcement authority specified in the federal regulations (e.g., 40 C.F.R. sections 122.41(j)(5) and (k)(2)).
- 6.1.2.2. Order Provision 6.1.2.2 requires the Permittee to notify Regional Water Board staff, orally and in writing, in the event that the Permittee does not comply or will be unable to comply with any Order requirement. This provision requires the Permittee to make direct contact with a Regional Water Board staff person.

6.2. Monitoring and Reporting Program (MRP) Requirements

The Permittee shall comply with the MRP, included as Attachment E of this Order, and future revisions thereto.

6.3. Special Provisions

6.3.1. Reopener Provisions

6.3.1.1. **Standard Revisions (Special Provision 6.3.1.1).** Conditions that necessitate a major modification of a permit are described in 40 C.F.R. section 122.62, which include the following:

6.3.1.1.1. When standards or regulations on which the permit was based have been changed by promulgation of amended standards or regulations or by judicial decision. Therefore, if revisions of applicable water quality standards are promulgated or approved pursuant to section 303 of the CWA or amendments thereto, the Regional Water Board will revise and modify this Order in accordance with such revised standards.

6.3.1.1.2. When new information that was not available at the time of permit issuance would have justified different permit conditions at the time of issuance.

6.3.1.2. **Reasonable Potential (Special Provision 6.3.1.2).** This provision allows the Regional Water Board to modify, or revoke and reissue, this Order if present or future investigations demonstrate that the Permittee governed by this Permit is causing or contributing to excursions above any applicable priority pollutant criterion or objective, or adversely impacting water quality and/or the beneficial uses of receiving waters.

6.3.1.3. **Whole Effluent Toxicity (Special Provision 6.3.1.3).** This Order requires the Permittee to investigate the causes of and identify corrective actions to reduce or eliminate effluent toxicity through a TRE. This Order may be reopened to include a numeric chronic toxicity limitation, new acute toxicity limitation, representative IWC, and/or a limitation for a specific toxicant identified in the TRE.

6.3.1.4. **303(d)-Listed Pollutants (Special Provision 6.3.1.4).** This provision allows the Regional Water Board to reopen this Order to modify existing effluent limitations or add effluent limitations for pollutants that are the subject of any future TMDL action.

6.3.1.5. **Water Effects Ratios (WERs) and Metal Translators (Special Provision 6.3.1.5).** This provision allows the Regional Water Board to reopen this Order if future studies undertaken by the Permittee provide new information and justification for applying a WER or metal translator to a water quality objective for one or more priority pollutants.

6.3.1.6. **Nutrients (Special Provision 6.3.1.6).** This Order contains monitoring requirements for nutrients (ammonia, unionized ammonia, nitrate, nitrite,

organic nitrogen, and phosphorus). This provision allows the Regional Water Board to reopen this Order if future monitoring data indicates the need for new or revised effluent limitations for any of these parameters.

- 6.3.1.7. **Salt and Nutrient Management Plans (Special Provision 6.3.1.7).** This provision allows the Regional Water Board to reopen this Order if needed to incorporate provisions consistent with any Regional or sub-regional salt and nutrient management plan(s) adopted by the Regional Water Board or any amendments to the Recycled Water Policy that are applicable to the Permittee.
- 6.3.1.8. **Title 22 Engineering Report (Special Provision 6.3.1.8).** This provision allows the Regional Water Board to reopen this Order to adequately implement title 22, if necessary, based on the Permittee's title 22 engineering report.
- 6.3.1.9. **Pathogens (Special Provision 6.3.1.9).** This provision allows the Regional Water Board to reopen this Order if needed, to adequately implement the Regional Water Board's Russian River Pathogen TMDL.
- 6.3.1.10. **Pretreatment Program (Special Provision 6.3.1.10).** This provision allows the Regional Water Board to reopen this Order if needed to require the development of a pretreatment program if source control activities indicate that a pretreatment program is necessary, pursuant to 40 C.F.R. section 403.8(3).

6.3.2. **Special Studies and Additional Monitoring Requirements**

- 6.3.2.1. **Land Discharge/Recycled Water Operations and Management Plan (Special Provision 6.3.2.1).** This requirement is retained in part from Order No. R1-2014-0002 and expanded to include land discharge management. The Land Discharge/Recycled Water Operations and Management Plan is necessary to ensure that the recycled water irrigation system is operated at appropriate hydraulic and nutrient agronomic rates, utilizing appropriate BMPs and operations practices. The Land Discharge section of the Management Plan section of the Management Plan is necessary to ensure that irrigation on the Burch Property is conducted in a manner that ensures compliance with Land Discharge Requirements 4.2.2.2 through 4.2.2.11. Since site-specific evapotranspiration (ET) rates in the spray disposal area are unknown, it is essential that an Irrigation Discharge Management Plan be prepared, implemented, and modified as necessary to ensure that spray irrigation rates minimize ponding, flow in surface water drainages and ephemeral watercourses, and/or adverse impacts to groundwater.
- 6.3.2.2. **Pathogen Special Study (Special Provision 6.3.2.2).** The Regional Water Board adopted the Action Plan for the Russian River Watershed Pathogen

TMDL (Pathogen TMDL) in August 2019, and TMDL-driven effluent limitations may be implemented in future permits. The Pathogen TMDL notes that tertiary recycled water, such as that produced by the Facility, is fully disinfected and is not considered a source of pathogens of human origin; however, the TMDL expresses uncertainty about the potential for regrowth of pathogens of human origin, particularly after storage. This Order requires the Permittee to conduct a study to assess the Facility's ability to comply with the bacteria water quality objective in section 5.1.20 of the Order and required actions outlined in Table 4 of the Pathogen TMDL and to submit a report that summarizes the results of the Permittee's ability to comply with the bacteria water quality objective and the Pathogen TMDL, and, if necessary, a plan and schedule for achieving compliance with the Pathogen TMDL. The plan of compliance should identify any other studies necessary to demonstrate compliance with the bacteria water quality objective and the Pathogen TMDL (i.e., study to determine whether the discharge includes pathogens of human origin). The Regional Water Board will use the results of the study to inform the implementation of TMDL-based effluent limitations, if necessary, during the next permit renewal.

6.3.2.3. Disaster Preparedness Assessment Report and Action Plan (Special Provision 6.3.2.3) Natural disasters, extreme weather events, sea level rise, and shifting precipitation patterns, some of which are projected to intensify due to climate change, have significant implications for wastewater treatment and operations. Some natural disasters are expected to become more frequent and extreme according to the current science on climate change. In order to ensure that Facility operations are not disrupted, compliance with conditions of this Order are achieved, and receiving waters are not adversely impacted by permitted and unpermitted discharges, this Order requires the Permittee to submit a Disaster Preparedness Assessment Report and Action Plan.

6.3.3. Best Management Practices and Pollution Prevention

6.3.3.1. Pollutant Minimization Program (Special Provision 6.3.3.1). This provision is included in this Order pursuant to section 2.4.5 of the SIP. The Regional Water Board includes standard provisions in all NPDES permits requiring development of a Pollutant Minimization Program when there is evidence that a toxic pollutant is present in the effluent at a concentration greater than an applicable effluent limitation.

6.3.4. Construction, Operation, and Maintenance Specifications

6.3.4.1. Operation and Maintenance (Special Provisions 6.3.4). 40 C.F.R. section 122.41(e) requires proper operation and maintenance of permitted wastewater systems and related facilities to achieve compliance with permit conditions. An up-to-date operation and maintenance manual, as required by Provision

6.3.4.2 of this Order, is an integral part of a well-operated and maintained facility.

6.3.5. Special Provisions for Publicly-Owned Treatment Works (POTWs)

6.3.5.1. Wastewater Collection Systems (Special Provision 6.3.5.1)

6.3.5.1.1. Statewide General WDRs for Sanitary Sewer Systems. On May 2, 2006, the State Water Board adopted General Waste Discharge Requirements for Sanitary Sewer Systems, Water Quality Order No. 2006-0003-DWQ (General Order). The General Order requires public agencies that own or operate sanitary sewer systems with greater than one mile of pipes or sewer lines to enroll for coverage under the General Order. The General Order requires agencies to develop sanitary sewer management plans (SSMPs) and report all SSOs, among other requirements and prohibitions.

On February 20, 2008, the State Water Board adopted Order No. WQ 2008- 0002 EXEC *Adopting Amended Monitoring and Reporting Requirements for Statewide General Waste Discharge Requirements for Statewide General Waste Discharge Requirements for Sanitary Sewer Systems*, to ensure adequate and timely notifications are made to the Regional Water Board and appropriate local, state, and federal authorities in case of sewage spills. On August 6, 2013, the State Water Board adopted Order No. WQ 2013-0058-EXEC *Amending Monitoring and Reporting Program for Statewide General Waste Discharge Requirements for Sanitary Sewer Systems*. Order No. WQ 2013-0058-EXEC addressed compliance and enforceability of the Monitoring and Reporting Program and superseded the amendments in Order No. WQ-2008-0002-EXEC. Notification and reporting of SSOs is conducted in accordance with the requirements of Order Nos. 2006-0003 DWQ and WQ 2013-0058-EXEC, and any revisions thereto for operation of its wastewater collection system.

6.3.5.2. Source Control and Pretreatment Provisions (Special Provision 6.3.5.2).

Pursuant to Special Provision 6.3.5.2.1, the Permittee shall implement the necessary legal authorities to monitor and enforce source control standards, restrict discharges of toxic materials to the collection system, and inspect facilities connected to the system.

40 C.F.R. section 403.8(a) requires POTWs with a total design flow greater than 5 mgd and receiving pollutants which pass through or interfere with the operation of the POTW to establish a POTW Pretreatment Program. The Regional Water Board may also require that a POTW with a design flow of 5 mgd or less develop a POTW Pretreatment Program if the nature or volume of the industrial influent, treatment process upsets, violations of POTW effluent limitations, contamination of municipal sludge, or other circumstances

warrant in order to prevent interference or pass through. The average dry weather design flow of the Facility is less than 5 mgd; therefore, the Order does not require the Permittee to develop a pretreatment program that conforms to federal regulations. However, in order to prevent interference with the POTW or pass through of pollutants to the receiving water, the Order requires the Permittee to implement a source control program to ensure that all non-domestic facilities in the service area are being operated in a manner to prevent the discharge of pollutants that could pass through or interfere with the operation or performance of the Facility. During the term of Order No. R1-2014-0002, the Permittee conducted an industrial waste survey that demonstrated that there are no non-domestic facilities in the service area that could discharge pollutants that could pass through or interfere with the operation or performance of the Facility. The Permittee's annual reports provide a detailed summary of annual inspections at the non-domestic facilities that discharge waste to the collection system. The Permittee has demonstrated a commitment to regular inspections to provide on-going assessment of these non-domestic users.

If at any time, source control activities indicate that a pretreatment program is necessary, pursuant to 40 C.F.R. section 403.8(3), the Regional Water Board may reopen this permit to require the Permittee to develop a pretreatment program.

Water Code section 13263.3(d)(1) allows the Regional Water Board to require a discharger to complete and implement a pollution prevention plan if pollution prevention is necessary to achieve a water quality objective, to include, pursuant to Water Code section 13263.3(d)(3), an analysis of the methods that could be used to prevent the discharge of the pollutants into the POTW. These methods can include application of local limits to industrial or commercial dischargers, pollution prevention techniques, public education and outreach, or other innovative and alternative approaches to reduce discharges of pollutants to the POTW.

The analysis also shall identify sources, or potential sources, not within the ability or authority of the POTW to control, such as pollutants in the potable water supply, airborne pollutants, pharmaceuticals, or pesticides, and estimate the magnitude of those sources, to the extent feasible. This Order includes requirements for the Permittee to implement a source identification and reduction program.

A key component of an effective source control program is the identification and location of possible industrial users within the POTW's wastewater collection system. This information is typically obtained by the POTW through industrial waste surveys. The following types of resources can be consulted in compiling a master list of industrial users:

- i. Water and sewer billing records
- ii. Applications for sewer service
- iii. Local telephone directories
- iv. Chamber of Commerce and local business directories
- v. Business license records
- vi. POTW and wastewater collection personnel and field observations
- vii. Business associations
- viii. The internet
- ix. Industrial and non-residential sewer use permit records

In addition, the Regional Water Board recognizes that some form of source control is prudent to ensure the efficient operation of the Facility, the safety of Facility staff, and to ensure that pollutants do not pass through the treatment Facility to impair the beneficial uses of the receiving water. The proposed Order includes prohibitions for the discharge of pollutants that may interfere, pass through, or be incompatible with treatment operations, interfere with the use of disposal of sludge, or pose a health hazard to personnel.

6.3.5.3. Sludge Disposal and Handling Requirements (Special Provision 6.3.5.3).

The disposal or reuse of wastewater treatment screenings, sludges, or other solids removed from the liquid waste stream is regulated by 40 C.F.R. parts 257, 258, 501, and 503, and the State Water Board promulgated provisions of title 27 of the CCR.

The Permittee has indicated that all screenings, sludges, and solids removed from the liquid waste stream are currently disposed of off-site at a permitted point of disposal (typically a municipal solid waste landfill) in accordance with all applicable regulations.

6.3.5.4. Biosolids Management (Special Provision 6.3.5.4). This provision requires the Permittee to comply with the State's regulations relating to the discharge of biosolids to the land. The discharge of biosolids through land application is not regulated under this Order. If the Permittee intends to dispose of biosolids through its beneficial reuse as soil amendment, the Permittee is required to obtain coverage under the State Water Board Order No. 2004-0012-DWQ, *General Waste Discharge Requirements for the Discharge of Biosolids to Land as a Soil Amendment in Agricultural, Silvicultural, Horticultural, and Land Reclamation Activities* (General Order). Coverage under the General Order, as opposed to coverage under this NPDES permit or individual WDRs, implements a consistent statewide approach to regulating this waste discharge.

6.3.5.5. Operator Certification (Special Provision 6.3.5.5). This provision requires the Facility to be operated by supervisors and operators who are certified as required by title 23, section 3680 of the CCR.

6.3.5.6. **Adequate Capacity (Special Provision 6.3.5.6).** The goal of this provision is to ensure appropriate and timely planning by the Permittee to ensure adequate capacity for the protection of public health and water quality.

6.3.6. **Other Special Provisions**

6.3.6.1. **Storm Water (Special Provision 6.3.6.1).** This provision requires the Permittee, if applicable, to obtain coverage under the State Water Board's Water Quality Order No. 2014-0057-DWQ, NPDES General Permit No. CAS000001, *General Permit for Storm Water Discharges Associated with Industrial Activities* (or subsequent renewed versions of the NPDES General Permit CAS000001). Currently, the Facility is exempted from these requirements based on a design flow of less than 1.0 mgd.

The Facility employs storm water BMPs to divert storm water and prevent it from entering the Facility grounds. The Order requires the Permittee to implement and maintain BMPs to control the run-on of storm water to the Facility and to describe the effectiveness of these storm water BMPs, as well as activities to maintain and upgrade these BMPs during the previous year, in its Annual Facility Report to the Regional Water Board.

6.3.6.2. **Flood Control and Flow Reduction Mitigation (Special Provision 6.3.6.2).**

This provision is included to ensure that the Permittee implements measures and actions to minimize the potential for sanitary sewer overflows and bypass events at the Facility. Although the Facility was expanded in early 2005 to increase the wet weather sustained capacity of 3.5 mgd, it is necessary for flood control and flood reduction measures to occur on an ongoing basis and prior to storm events to minimize the potential for SSOs and bypass events to occur.

In previous permits, this provision was based in part on the Permittee's *Collection System Operations and Maintenance Plan* dated September 2001 and the findings of Tetra Tech Diagnostic Inspection Report, which summarized findings of an inspection that occurred on March 19 and 20, 2008. The purpose of the inspection was to investigate the effect of I/I on Facility performance, the adequacy of collection system design, and compliance with SSO requirements.

Flood events that occurred in early 2017 and 2019 resulted in several large SSOs, demonstrating the need for further action on the part of the Permittee to achieve flood control and flow reduction mitigation. In 2017, the Permittee reported three large SSOs at an estimated cumulative volume of 1,031,663 gallons. In 2019, the Permittee reported three large SSOs and two smaller SSOs at an estimated cumulative volume of 1,312,815 gallons. The largest

2017 spill occurred when the Vacation Beach Lift Station lost auxiliary power during a severe wet weather event and major flooding along the Russian River, resulting in a spill volume of 769,500 gallons of raw sewage mixed with flood water that had entered the collection system. These SSOs occur in neighborhoods and pose a public health risk to the residents. Although, evacuation orders are declared during flood conditions, some residents stay in their homes and neighborhoods during these flood events. In addition, in 2017, 337,000 gallons of untreated wastewater spilled at the treatment plant and 1,650,000 gallons of partially treated wastewater was blended with 6,400,000 gallons of fully treated, disinfected tertiary effluent and discharged to the Russian River.

The spills that occurred in 2017 and 2019 indicate that measures that the Permittee has implemented per the Permittee's 2001 *Collection System Operations and Maintenance Plan* have not been completely effective and demonstrate the need for additional assessment and corrective work to address this problem.

This Order requires the Permittee to submit a work plan for revising its Sewer Evaluation and Capacity Assurance Plan that is required by section 13(viii) of the *Statewide General Waste Discharge Requirements for Sanitary Sewer Systems*, WQO No. 2006-0003 to consider the location of the collection system in a flood plain and to utilize an appropriate storm return frequency in consideration of the 2017 and 2019 storms that resulted in flooding and sewer overflows. This Order also requires the Permittee to conduct an engineering evaluation to document the interaction between the collection system and the treatment plant and collection system during high flow and flood events and to complete the evaluation and submit a final report that describes deficiencies in the collection system and the treatment plant and engineering and contingency measures a Capital Improvement Plan that will be implemented to prevent, reduce, and mitigate for spills, and protect public health.

In response to public comments received during the adoption of Order No. R1-2023-0049, Settlement Agreement and Stipulation for Entry of Order for the Sonoma County Water Agency and Russian River County Sanitation District, this Order has been modified to require that the Engineering Evaluation Final Report include a schedule of implementation for all corrective actions identified to be submitted for Executive Officer review and approval. Additionally, The Order has been modified to include a requirement for the Permittees to submit an updated Collection System Operations and Maintenance Plan to reflect those identified corrective actions that may be immediately implemented. These changes are necessary to ensure that identified corrective actions are implemented by the Permittees in a timely manner, to eliminate, reduce, and mitigate overflow events.

6.3.7. **Compliance Schedules – Not Applicable**

This Order does not establish interim effluent limitations or schedules of compliance for final numeric effluent limitations.

7. **RATIONALE FOR MONITORING AND REPORTING REQUIREMENTS**

Section 122.48 of 40 C.F.R. requires that all NPDES permits specify requirements for recording and reporting monitoring results. Water Code section 13383 authorizes the Regional Water Board to require technical and monitoring reports. The MRP, Attachment E, establishes monitoring and reporting requirements that implement federal and state requirements. The following provides the rationale for the monitoring and reporting requirements contained in the MRP for this Facility.

7.1. **Influent Monitoring**

- 7.1.1. Influent monitoring requirements at Monitoring Location INF-001 for BOD₅ and TSS are retained from Order No. R1-2014-0002 and are necessary to determine compliance with the Order's 85 percent removal requirement for these parameters.
- 7.1.2. Influent monitoring requirements for flow at Monitoring Location INF-001 are retained from Order No. R1-2014-0002 and are necessary to determine compliance with Discharge Prohibition 3.8.

7.2. **Effluent Monitoring**

- 7.2.1. Effluent monitoring requirements are necessary to determine compliance with prohibitions and/or effluent limitations established by the Order. Monitoring at Monitoring Locations EFF-001, EFF-002, and EFF-005 is necessary to demonstrate compliance with effluent limitations and demonstrate whether or not the discharge poses reasonable potential for a pollutant to exceed any numeric or narrative water quality objectives.

7.2.1.1. **Monitoring Location EFF-001.**

- 7.2.1.1.1. Effluent monitoring frequencies and sample types for flow, BOD₅, TSS, pH, and total coliform bacteria, at Monitoring Location EFF-001 have been retained from Order No. R1-2014-0002.
- 7.2.1.1.2. Effluent monitoring requirements for radioactivity at Monitoring Location EFF-001 have been removed because monitoring data submitted during the term of Order No. R1-2014-0002 demonstrated compliance with the water quality objective for radioactivity in the Basin Plan.

7.2.1.2. **Monitoring Location EFF-002**

- 7.2.1.2.1. Effluent monitoring frequencies and sample types for flow, discharge dilution rate, pH, dissolved oxygen, hardness, specific conductance, temperature, total dissolved solids, aluminum, total ammonia, unionized ammonia, nitrate, organic nitrogen, and phosphorus at Monitoring Location EFF-002 have been retained from Order No. R1-2014-0002. A new requirement to calculate and report total nitrogen is also included.
- 7.2.1.2.2. The monitoring frequency for hardness has been reduced from once per discharge season to once per permit term to correspond with the once per permit term monitoring requirement for CTR priority pollutants. The higher monitoring frequency for hardness in Order No. R1-2014-0002 was necessary because of the once per discharge season monitoring requirement for copper.
- 7.2.1.2.3. Effluent monitoring data collected during the term of Order No. R1-2014-0002 indicates that the discharge does not exhibit reasonable potential to cause or contribute to an exceedance of water quality objectives for copper and bis(2-ethylhexyl)phthalate. Therefore, this Order discontinues effluent monitoring requirements for copper and bis(2-ethylhexyl)phthalate.
- 7.2.1.2.4. Weekly effluent monitoring for *E. coli* bacteria has been established in this Order to ensure that adequate monitoring data is available to assess reasonable potential for the discharge to cause or contribute to an exceedance of new water quality objectives for *E. coli* bacteria and ensure compliance with the Pathogen TMDL during periods of discharge from storage to receiving waters.
- 7.2.1.2.5. On December 21, 2018, U.S. EPA finalized updated NAWQC for aluminum in freshwater that reflect the latest science and allow for development of criteria reflecting the impact of local water chemistry on aluminum toxicity to aquatic life. The updated criteria account for the site-specific bioavailability of aluminum in receiving waters, which is dependent on pH, dissolved organic carbon, and hardness. This Order establishes monthly effluent monitoring requirements for aluminum to collect sufficient data for calculating site-specific freshwater aluminum criteria in accordance with the 2018 NAWQC prior to the next permit renewal.
- 7.2.1.2.6. This Order includes a new monthly effluent monitoring requirement for mercury to ensure that adequate monitoring data is available to assess reasonable potential against the Statewide Mercury Provisions.
- 7.2.1.2.7. Consistent with Order No. R1-2014-0002, this Order requires effluent monitoring for CTR priority pollutants once per permit term at Monitoring Location EFF-002 to generate adequate data to perform an RPA. The sample type for CTR priority pollutants has been changed from grab to 24-

hour composite, with the exception of those priority pollutants that are volatile. The once per permit term CTR priority pollutant monitoring must be performed in time to submit the data with the Report of Waste Discharge; therefore, Table Note 9 in Table E-4 of the MRP specifies that this monitoring must be completed by **March 1, 2025**.

7.2.1.2.8. This Order eliminates the effluent monitoring requirement for title 22 pollutants due to the fact that monitoring during the term of Order No. R1-2014-0002 demonstrated that no title 22 pollutants, except nitrite and aluminum, were detected in notable concentrations in the effluent. Aluminum exhibited reasonable potential to exceed applicable water quality objectives so effluent limitations have been established for this pollutant in the Order and monitoring requirements for aluminum have been retained from Order No. R1-2014-0002. Additionally, monitoring requirements for nitrite have been established in this Order.

7.2.1.3. **Monitoring Location EFF-005**

7.2.1.3.1. A new monitoring location, EFF-005, has been added, to represent any direct discharges from the treatment plant to the Russian River without utilizing the effluent storage pond. This monitoring location may be used if the storage pond needs to be taken off-line for maintenance or to address issues that could lead to exceedance of effluent limitations.

7.2.1.3.2. Whenever there are direct discharges from the treatment plant to the Russian River, monitoring must be conducted for technology-based parameters identified in Table E-3 of the MRP and water quality-based parameters identified in Table E-4 of the MRP.

7.3. **Whole Effluent Toxicity Testing Requirements**

WET monitoring requirements are retained from Order No. R1-2014-0002 and are included in this Order to protect the receiving water quality from the aggregate effect of a mixture of pollutants in the effluent. Acute toxicity testing measures mortality in 100 percent effluent over a short test period and chronic toxicity testing is conducted over a longer time period and may measure mortality, reproduction, and/or growth. This Order retains annual monitoring requirements for acute and chronic toxicity.

In addition to routine toxicity monitoring, this Order requires the Permittee to maintain and update their TRE Work Plan, in accordance with appropriate U.S. EPA guidance, to ensure that the Permittee has a plan to immediately move forward with the initial tiers of a TRE in the event effluent toxicity is encountered in the future. The TRE is initiated by evidence of a pattern of toxicity demonstrated

through the additional effluent monitoring provided as a result of an accelerated monitoring program.

7.4. Land Discharge Monitoring Requirements (LND-001)

- 7.4.1. Effluent monitoring frequencies and sample types for flow, pH, nitrate, total dissolved solids, total recoverable aluminum, and visual observations at Monitoring Location LND-001 have been retained from Order No. R1-2014-0002.
- 7.4.2. Effluent monitoring for sodium has been reduced to annual because monitoring data since 2016 has demonstrated that sodium concentrations have been reduced below the U.S. EPA Drinking Water Advisory Taste and Odor threshold of 60 mg/L.
- 7.4.3. New monitoring requirements for ammonia, nitrite, and total organic nitrogen are included along with a requirement to calculate and report total nitrogen.
- 7.4.4. New monitoring locations for reporting flow to the Upper and Lower Burch properties have been established as LND-001U and LND-001L, respectively.

7.5. Recycled Water Monitoring Requirements (REC-001)

- 7.5.1. This Order requires the Permittee to comply with applicable state and local requirements regarding the production and use of recycled water.
- 7.5.2. Recycled water monitoring requirements at Monitoring Location REC-001 for ammonia, nitrate, nitrite, total organic nitrogen, and visual observations have been retained from Order No. R1-2014-0002. A new requirement to calculate and report total nitrogen is also included.
- 7.5.3. Recycled water monitoring requirements at Monitoring Location REC-001 for sodium have been retained from Order No. R1-2014-0002, but the monitoring frequency has been reduced to annual because monitoring data since 2016 has demonstrated that sodium concentrations have been reduced below the U.S. EPA Drinking Water Advisory Taste and Odor threshold of 60 mg/L.
- 7.5.4. Recycled water monitoring data collected during the term of Order No. R1-2014-0002 indicates that the recycled water does not exhibit reasonable potential to cause or contribute to an exceedance of water quality objectives for chloride, boron, or total dissolved solids for the protection of groundwater. Therefore, this Order discontinues recycled water monitoring requirements for chloride, boron and total dissolved solids.
- 7.5.5. Recycled water production and use requirements in Table E-7 have been expanded to provide clarity and to match requirements in the State Water Board

Order WQ 2016-0068-DDW, Water Reclamation Requirements for Recycled Water Use.

7.6. Receiving Water Monitoring

7.6.1. Surface Water

7.6.1.1. Monitoring Location RSW-001

- 7.6.1.1.1. Receiving water monitoring is required to demonstrate compliance with the Receiving Water Limitations. Monitoring requirements for flow, pH, dissolved oxygen, specific conductance, temperature, total dissolved solids, and turbidity have been retained from Order No. R1-014-0002.
- 7.6.1.1.2. Receiving water monitoring results for total ammonia, unionized ammonia, nitrate, organic nitrogen, and phosphorus did not vary significantly during the term of Order No. R1-2014-0002, therefore monitoring for these parameters has been reduced from monthly to semiannually.
- 7.6.1.1.3. This Order increases receiving water monitoring for hardness from once per permit term to monthly and establishes monthly receiving water monitoring requirements for aluminum and dissolved organic carbon to collect sufficient data for evaluating aluminum in the receiving water and calculating site-specific freshwater aluminum criteria in accordance with the 2018 NAWQC prior to the next permit renewal.
- 7.6.1.1.4. The once per permit term CTR priority pollutant monitoring must be performed in time to submit the data with the Report of Waste Discharge; therefore, Table Note 8 in Table E-8 of the MRP specifies that this monitoring must be completed by **March 1, 2025**.
- 7.6.1.1.5. This Order includes a new monthly receiving water monitoring requirement for mercury to ensure that adequate monitoring data is available to assess reasonable potential against the Statewide Mercury Provisions.

7.6.1.2. Monitoring Locations RSW-003 and RSW-004

- 7.6.1.2.1. Receiving water monitoring requirements for pH, dissolved oxygen, specific conductance, temperature, total dissolved solids, and turbidity have been retained from Order No. R1-2014-0002.

7.6.2. Groundwater

- 7.6.2.1. The Recycled Water Policy requires the development of salt and nutrient management plans (SNMP) for groundwater basins in the State. In the absence of a regional or sub-regional SNMP effort, the regional water boards

have the discretion to require groundwater monitoring and/or detailed antidegradation analyses to determine whether or not groundwater is being or has the potential of being impacted by the storage and use of recycled water.

- 7.6.2.2. Groundwater monitoring is necessary to evaluate whether or not the land application of effluent at greater than agronomic rates is impacting groundwater. Furthermore, the Regional Water Board has the unique challenge of protecting and preserving high quality groundwater and its beneficial uses while enabling sustainable practices, such as use of recycled water, and while allowing land discharge practices. Groundwater monitoring is a tool to identify groundwater issues and modify practices, as necessary, to allow the continued use of recycled water and protect groundwater.
- 7.6.2.3. Groundwater monitoring requirements at Monitoring Locations GW-001, GW-002, and GW-003 for depth to groundwater, pH, nitrate, total dissolved solids, sodium, chloride, and aluminum have been retained from Order No. R1-2014-0002.
- 7.6.2.4. Groundwater monitoring frequencies have been reduced to recognize the significant improvements to effluent quality that were achieved following completion of the biological nutrient removal project in 2014 that also resulted in significant improvement in groundwater in the vicinity of the Burch irrigation area where the groundwater monitoring wells are located.
 - 7.6.2.4.1. The monitoring frequency for measuring depth to groundwater is quarterly for all three wells.
 - 7.6.2.4.2. The pollutant monitoring frequency has been reduced from monthly to semiannual for the upgradient well, GW-003 and from monthly to quarterly for the two downgradient wells. The lower monitoring frequency is appropriate for the upgradient well because historical monitoring data has been consistent, with little variation and generally appears to be unaffected by wastewater effluent. The main purpose of the upgradient well is to provide an ongoing check of background water quality.
 - 7.6.2.4.3. Specific months for monitoring the upgradient and downgradient wells are specified to recognize the following:
 - 7.6.2.4.3.1. Downgradient monitoring is required during the months of February, May, August, and November. While the period of land application is May-Oct, there is a lag between the end of land application and what is mostly dilution (and perhaps some advection) of nitrate in groundwater as recorded in the monitoring wells. Depending on the precipitation pattern in any given rainy season, the nitrate might not be diluted until December or January.

- 7.6.2.4.3.2. Upgradient monitoring is required during the months of May and August to ensure that there is background data during the land application season.
- 7.6.2.4.3.3. If, in the future, downgradient monitoring frequency is reduced to semiannual, then both upgradient and downgradient monitoring would be required in August and February to document groundwater quality during the irrigation season and to check for attenuation of nitrate by the middle of the rainy season.

7.7. Other Monitoring Requirements

- 7.7.1. **Filtration Process Requirements (Monitoring Locations INT-001A and INT-001B).** Monitoring of the surface loading rate at Monitoring Location INT-001A is necessary to demonstrate compliance with technology requirements set forth in DDW's *Alternative Treatment Technology Report for Recycled Water* (September 2014 or subsequent) and the June 29, 2001 DHS letter to Aqua-Aerobics identifying conditions of acceptance for the cloth media filters. Monitoring of filter influent turbidity at INT-001A is required to demonstrate compliance with conditions in the May 6, 2002 (Corrected Copy – January 13, 2009) DHS letter. Monitoring of effluent turbidity of the tertiary filters at Monitoring Location INT-001B is required to demonstrate compliance with section 60301.320 of title 22 CCR filtration requirements for disinfected tertiary recycled water.
- 7.7.2. **Disinfection Process Monitoring for UV Disinfection System (Monitoring Location INT-002).** UV disinfection system monitoring requirements at Monitoring Location INT-002 are included to assess compliance of the UV disinfection system with title 22 and guidelines established by the National Water Research Institute (NWRI) and American Water Works Association Research Foundation (AWWARF) *Ultraviolet Disinfection Guidelines for Drinking Water and Water Reuse* (3rd or subsequent editions).
- 7.7.3. **Visual Monitoring (Monitoring Locations EFF-001, EFF-002, RSW-003 and RSW-004).** Visual monitoring requirements at Monitoring Locations EFF-001, EFF-002, RSW-003 and RSW-004 are retained from Order No. R1-2014-0002 and are necessary to ensure compliance with receiving water limitations in section 5. of the Order.
- 7.7.4. **Sludge Monitoring (Monitoring Location BIO-001).** Sludge monitoring requirements at Monitoring Location BIO-001 are retained from Order No. R1-2014-0002 and serve as a basis for the Permittee to develop the sludge

Handling and Disposal report that is required as part of the Annual Report pursuant to section 10.4.2.7 of the MRP.

- 7.7.5. **Discharge Monitoring Report-Quality Assurance (DMR-QA) Study Program.** Under the authority of section 308 of the CWA (33 U.S.C. § 1318), U.S. EPA requires major and selected minor dischargers under the NPDES Program to participate in the annual DMR-QA Study Program. The DMR-QA Study evaluates the analytical ability of laboratories that routinely perform or support self-monitoring analyses required by NPDES permits. There are two options to satisfy the requirements of the DMR-QA Study Program: (1) The Permittee can obtain and analyze a DMR-QA sample as part of the DMR-QA Study; or (2) Per the waiver issued by U.S. EPA to the State Water Board, the Permittee can submit the results of the most recent Water Pollution Performance Evaluation Study from its own laboratories or its contract laboratories. A Water Pollution Performance Evaluation Study is similar to the DMR-QA Study. Thus, it also evaluates a laboratory's ability to analyze wastewater samples to produce quality data that ensure the integrity of the NPDES Program. The Permittee shall ensure that the results of the DMR-QA Study or the results of the most recent Water Pollution Performance Evaluation Study are submitted annually to the State Water Board. The State Water Board's Quality Assurance Program Officer will send the DMR-QA Study results or the results of the most recent Water Pollution Performance Evaluation Study to U.S. EPA's DMR-QA Coordinator and Quality Assurance Manager.
- 7.7.6. **Accelerated Monitoring Requirements.** Tables E-3, E-4, E-5, and E-6 of the MRP include accelerated monitoring requirements for parameters that are required to be monitored daily, weekly, and monthly.
- 7.7.7. **Flow Monitoring.** Section 1.4 of the MRP requires proper installation, calibration, operation, and maintenance of flow metering devices.
- 7.7.8. **Spill Notification.** Section 10.5 of the MRP that is part of this Order establishes requirements for reporting spills and unauthorized discharges, with the exception of SSOs, which must be reported in accordance with the requirements of State Water Board Order No. 2006-0003-DWQ and WQ-2013-0058-EXEC and any future revisions.
- 7.7.9. **Volumetric Reporting.** Section 10.4.3 of the MRP requires reporting of influent volumes, discharge volumes and reuse volumes from the Facility as part of an annual report submitted to GeoTracker. These reporting requirements are in accordance with Order No. WQ 2019-0037-EXEC and any future revisions. Volumetric reporting requirements have been limited to discharge locations and uses that the Permittee currently utilizes. If additional discharge locations or use types are added in the future, the volumetric reporting language should be updated accordingly.

7.7.10. **Public Spill Notification Plan.** MRP section 10.5.2 requires the Permittee to develop a plan for notifying the public of spills. The public spill notification plan must demonstrate that adequate plans and procedures are in place to ensure that residents in the immediate vicinity of the spill and downstream community members that may be affected by spills into neighborhoods and receiving waters are properly notified and that development of the Plan included a public participation process.

8. PUBLIC PARTICIPATION

The California Regional Water Quality Control Board, North Coast Region (Regional Water Board) is considering the issuance of waste discharge requirements (WDRs) that will serve as a National Pollutant Discharge Elimination System (NPDES) permit for the Russian River County Sanitation District and Sonoma Water, Russian River Wastewater Treatment Facility. As a step in the WDR adoption process, the Regional Water Board staff has developed tentative WDRs. The Regional Water Board encourages public participation in the WDR adoption process.

8.1. Notification of Interested Parties

The Regional Water Board notified the Permittee and interested agencies and persons of its intent to prescribe waste discharge requirements for the discharge and provided an opportunity to submit written comments and recommendations. Notification was provided through the following posting on the Regional Water Board's Internet site at:

http://www.waterboards.ca.gov/northcoast/public_notices/public_hearings/npdes_permits_and_wdrs.shtml.

Additionally, the Regional Water Board notified the Permittees and interested agencies and persons of its intent to modify Order No. R1-2021-0002 and provided the opportunity to submit written comments and recommendations. Notification was provided through posting on the [Regional Water Board's Internet site](#) at:

http://www.waterboards.ca.gov/northcoast/public_notices/public_hearings/npdes_permits_and_wdrs.shtml on September 6, 2024. On December 4-5, 2024, after due notice to the Permittees and all other affected persons, the Regional Water Board conducted a public hearing and evidence was received regarding adoption of Order No. R1-2024-0030, modifying Order No. R1-2021-0002.

8.2. Written Comments

Interested persons were invited to submit written comments concerning these tentative WDRs as provided through the notification process. Comments were due to the Regional Water Board Executive Office electronically via e-mail to NorthCoast@waterboards.ca.gov or on disk (CD or DCD) in Portable Document

Format (PDF) file in lieu of paper-sourced documents. The guidelines for electronic submittal of documents can be found on the Regional Water Board website at <http://www.waterboards.ca.gov/northcoast>.

To be fully responded to by staff and considered by the Regional Water Board, the written comments were due at the Regional Water Board office by 5:00 p.m. on **April 14, 2021**.

Furthermore, to be fully responded to by staff and considered by the Regional Water Board, written comments on modifications to Order No. R1-2021-0002 contained in Order No. R1-2024-0030 were due at the Regional Water Board offices by 5:00 p.m. on October 7, 2024.

8.3. **Public Hearing**

The Regional Water Board held a public hearing on the tentative WDRs during its regular Board meeting on the following date and time and at the following location:

Date: **June 17, 2021**
Time: 8:30 a.m. or as announced in the Regional Water Board's agenda
Location: No physical meeting location (Authorized by and in furtherance of Executive Orders N-29-20 and N-33-20.)

As a result of the COVID-19 emergency and the Governor's Executive Orders to protect public health by limiting public gatherings and requiring social distancing, this meeting occurred solely via remote presence.

Interested persons were invited to attend/participate. At the public hearing, the Regional Water Board heard testimony pertinent to the discharge, WDRs, and permit. For accuracy of the record, important testimony was requested in writing.

Please be aware that dates and venues may change. Our Web address is <http://www.waterboards.ca.gov/northcoast> where you can access the current agenda for changes in dates and locations.

8.4. **Waste Discharge Requirements and Petitions**

Any person aggrieved by this action of the Regional Water Board may petition the State Water Board to review the action in accordance with Water Code section 13320 and California Code of Regulations, title 23, sections 2050 and following. The State Water Board must receive the petition by 5:00 p.m., within 30 calendar days of the date of adoption of this Order at the following address, except that if the thirtieth day following the date of this Order falls on a Saturday, Sunday, or

state holiday, the petition must be received by the State Water Board by 5:00 p.m. on the next business day:

State Water Resources Control Board
Office of Chief Counsel
P.O. Box 100, 1001 I Street
Sacramento, CA 95812-0100

Or by email at waterqualitypetitions@waterboards.ca.gov

For instructions on how to file a petition for review, see the [Water Quality Petitions Website](http://www.waterboards.ca.gov/public_notices/petitions/water_quality/wqpetition_instr.shtml)
(http://www.waterboards.ca.gov/public_notices/petitions/water_quality/wqpetition_instr.shtml.)

8.5. **Information and Copying**

The Report of Waste Discharge, other supporting documents, and comments received are on file and may be inspected at the address above at any time between 8:30 a.m. and 4:45 p.m., Monday through Friday. Copying of documents may be arranged through the Regional Water Board by calling (707) 576 2220.

8.6. **Register of Interested Persons**

Any person interested in being placed on the mailing list for information regarding the WDRs and NPDES permit should contact the Regional Water Board, reference this facility, and provide a name, address, and phone number.

8.7. **Additional Information**

Requests for additional information or questions regarding this order should be directed to Cathleen Goodwin at Cathleen.Goodwin@waterboards.ca.gov or (707) 576-2687.

Attachment F-1. Russian River CSD and Sonoma Water Reasonable Potential Analysis (RPA) Summary

Constituent	Units	Qualifier	MEC	Qualifier	B	C	CMC	CCC	Water & Org	Org. Only	MCL	RP
Antimony	µg/L	DNQ	0.36	=	0.085	6.0	--	--	14	--	6.0	No
Arsenic	µg/L	DNQ	0.94	=	1	10	340	150	--	--	10	No
Beryllium	µg/L	<	0.08	<	0.08	4.0	--	--	--	--	4.0	No
Cadmium	µg/L	<	0.08	<	0.08	2.0	3.3	2.0	--	--	5.0	No
Chromium (III)	µg/L	<	0.32	=	1.1	164	1,372	164	--	--	--	No
Chromium (VI)	µg/L	<	5	<	5	11	16	11	--	--	50	No
Copper	µg/L	=	10	=	1.1	18	26	18	1,300	--	--	No
Lead	µg/L	<	0.08	=	0.15	2.2	57	2.2	--	--	--	No
Mercury	µg/L	<	0.01 ¹	=	0.038 ¹	0.012 ²	--	--	0.050	--	2.0	No
Nickel	µg/L	=	13	=	4.6	41	368	41	610	--	100	No
Selenium	µg/L	<	0.28	<	0.28	5.0	--	5.0	--	--	50	No
Silver	µg/L	<	0.2	<	0.2	2.5	2.5	--	--	--	--	No
Thallium	µg/L	<	0.08	<	0.08	1.7	--	--	1.7	--	2.0	No
Zinc	µg/L	=	31	<	2	94	94	94	--	--	--	No
Cyanide	µg/L	<	2	<	2	5.2	22	5.2	700	--	150	No
Asbestos	MFL	<	2.2	<	3.7	7.0	--	--	7.0	--	7.0	No
2,3,7,8 TCDD	µg/L	<	1.77E-07	<	1.77E-07	1.3E-08	--	--	1.3E-08	--	3.0E-05	No

Constituent	Units	Qualifier	MEC	Qualifier	B	C	CMC	CCC	Water & Org	Org. Only	MCL	RP
Acrolein	µg/L	<	2	<	2	320	--	--	320	780	--	No
Acrylonitrile	µg/L	<	0.4	<	0.4	0.059	--	--	0.059	--	--	No
Benzene	µg/L	<	0.3	<	0.3	1.0	--	--	1.2	--	1.0	No
Bromoform	µg/L	<	0.3	<	0.3	4.3	--	--	4.3	--	--	No
Carbon Tetrachloride	µg/L	<	0.4	<	0.4	0.25	--	--	0.25	--	0.50	No
Chlorobenzene	µg/L	<	0.3	<	0.3	70	--	--	680	--	70	No
Chlorodibromomethane	µg/L	<	0.4	<	0.4	0.40	--	--	0.40	--	--	No
Chloroethane	µg/L	<	0.4	<	0.4	No Criteria	--	--	--	--	--	Uo ⁵
2-Chloroethylvinyl ether	µg/L	<	0.7	<	0.7	No Criteria	--	--	--	--	--	Uo ⁵
Chloroform	µg/L	<	0.4	<	0.4	No Criteria	--	--	--	--	--	Uo ⁵
Dichlorobromomethane	µg/L	<	0.4	<	0.4	0.56	--	--	0.56	--	--	No
1,1-Dichloroethane	µg/L	<	0.5	<	0.5	5.0	--	--	--	--	5.0	No
1,2-Dichloroethane	µg/L	<	0.4	<	0.4	0.38	--	--	0.38	--	0.50	No
1,1-Dichloroethylene	µg/L	<	0.3	<	0.3	0.057	--	--	0.057	--	6.0	No
1,2-Dichloropropane	µg/L	<	0.4	<	0.4	0.52	--	--	0.52	--	5.0	No
1,3-Dichloropropylene	µg/L	<	0.4	<	0.4	0.50	--	--	10	--	0.50	No
Ethylbenzene	µg/L	<	0.4	<	0.4	300	--	--	3,100	--	300	No

Constituent	Units	Qualifier	MEC	Qualifier	B	C	CMC	CCC	Water & Org	Org. Only	MCL	RP
Methyl Bromide	µg/L	<	0.4	<	0.4	48	--	--	48	--	--	No
Methyl Chloride	µg/L	<	0.4	<	0.4	No Criteria	--	--	--	--	--	Uo ⁵
Methylene Chloride	µg/L	<	0.5	<	0.5	4.7	--	--	4.7	--	5.0	No
1,1,2,2-Tetrachloroethane	µg/L	<	0.3	<	0.3	0.17	--	--	0.17	--	1.0	No
Tetrachloroethylene	µg/L	<	0.4	<	0.4	0.80	--	--	0.80	--	5.0	No
Toluene	µg/L	<	0.3	<	0.3	150	--	--	6,800	--	150	No
1,2-Trans-Dichloroethylene	µg/L	<	0.4	<	0.4	10	--	--	700	--	10	No
1,1,1-Trichloroethane	µg/L	<	0.4	<	0.4	200	--	--	--	--	200	No
1,1,2-Trichloroethane	µg/L	<	0.4	<	0.4	0.60	--	--	0.6	--	5.0	No
Trichloroethylene	µg/L	<	0.4	<	0.4	2.7	--	--	2.7	--	5.0	No
Vinyl Chloride	µg/L	<	0.4	<	0.4	0.50	--	--	2.0	--	0.5	No
2-Chlorophenol	µg/L	<	0.66	<	0.66	120	--	--	120	--	--	No
2,4-Dichlorophenol	µg/L	<	0.66	<	0.66	93	--	--	93	--	--	No
2,4-Dimethylphenol	µg/L	<	1.2	<	1.2	540	--	--	540	--	--	No
2-Methyl- 4,6-Dinitrophenol	µg/L	<	0.75	<	0.75	13	--	--	13	--	--	No
2,4-Dinitrophenol	µg/L	<	1.3	<	1.3	70	--	--	70	--	--	No

Constituent	Units	Qualifier	MEC	Qualifier	B	C	CMC	CCC	Water & Org	Org. Only	MCL	RP
2-Nitrophenol	µg/L	<	0.9	<	0.9	No Criteria	--	--	--	--	--	Uo ⁵
4-Nitrophenol	µg/L	<	0.99	<	0.99	No Criteria	--	--	--	--	--	Uo ⁵
3-Methyl 4-Chlorophenol	µg/L	<	0.58	<	0.58	No Criteria	--	--	--	--	--	Uo ⁵
Pentachlorophenol	µg/L	<	1.4	<	1.4	0.28	3.9	3.0	0.28	--	1.0	No
Phenol	µg/L	<	0.46	<	0.46	21,000	--	--	21,000	--	--	No
2,4,6-Trichlorophenol	µg/L	<	0.74	<	0.74	2.1	--	--	2.1	--	--	No
Acenaphthene	µg/L	<	0.57	<	0.57	1,200	--	--	1,200	--	--	No
Acenaphthylene	µg/L	<	0.48	<	0.48	No Criteria	--	--	--	--	--	Uo ⁵
Anthracene	µg/L	<	0.39	<	0.39	9,600	--	--	9,600	--	--	No
Benzidine	µg/L	<	3.4	<	3.4	0.00012	--	--	0.00012	--	--	No
Benzo(a)Anthracene	µg/L	<	0.39	<	0.39	0.0044	--	--	0.0044	--	--	No
Benzo(a)Pyrene	µg/L	<	0.5	<	0.5	0.0044	--	--	0.0044	--	0.20	No
Benzo(b)Fluoranthene	µg/L	<	0.64	<	0.64	0.0044	--	--	0.0044	--	--	No
Benzo(ghi)Perylene	µg/L	<	0.93	<	0.93	No Criteria	--	--	--	--	--	Uo ⁵
Benzo(k)Fluoranthene	µg/L	<	0.34	<	0.34	0.0044	--	--	0.0044	--	--	No

Constituent	Units	Qualifier	MEC	Qualifier	B	C	CMC	CCC	Water & Org	Org. Only	MCL	RP
Bis(2-Chloroethoxy)Methane	µg/L	<	0.81	<	0.81	No Criteria	--	--	--	--	--	Uo ⁵
Bis(2-Chloroethyl)Ether	µg/L	<	0.14	<	0.14	0.031	--	--	0.031	--	--	No
Bis(2-Chloroisopropyl)Ether	µg/L	<	0.41	<	0.41	1,400	--	--	1,400	--	--	No
Bis(2-Ethylhexyl)Phthalate	µg/L	<	0.83 ³	<	0.83 ³	1.8	--	--	1.8	--	4.0	Uo ⁵
4-Bromophenyl Phenyl Ether	µg/L	<	0.43	<	0.43	No Criteria	--	--	--	--	--	Uo ⁵
Butylbenzyl Phthalate	µg/L	<	0.64	<	0.64	3,000	--	--	3,000	--	--	No
2-Chloronaphthalene	µg/L	<	0.57	<	0.57	1,700	--	--	1,700	--	--	No
4-Chlorophenyl Phenyl Ether	µg/L	<	0.93	<	0.93	No Criteria	--	--	--	--	--	Uo ⁵
Chrysene	µg/L	<	0.76	<	0.76	0.0044	--	--	0.0044	--	--	No
Dibenzo(a,h)Anthracene	µg/L	<	0.83	<	0.83	0.0044	--	--	0.0044	--	--	No
1,2-Dichlorobenzene	µg/L	<	0.4	<	0.4	600	--	--	2,700	--	600	No
1,3-Dichlorobenzene	µg/L	<	0.4	<	0.4	400	--	--	400	--	--	No
1,4-Dichlorobenzene	µg/L	<	0.3	<	0.3	5.0	--	--	400	--	5.0	No
3,3 Dichlorobenzidine	µg/L	<	2	<	2	0.04	--	--	0.040	--	--	No
Diethyl Phthalate	µg/L	<	0.86	<	0.86	23,000	--	--	23,000	--	--	No
Dimethyl Phthalate	µg/L	<	0.68	<	0.68	313,000	--	--	313,000	--	--	No

Constituent	Units	Qualifier	MEC	Qualifier	B	C	CMC	CCC	Water & Org	Org. Only	MCL	RP
Di-n-Butyl Phthalate	µg/L	<	0.91	<	0.91	2,700	--	--	2,700	--	--	No
2,4-Dinitrotoluene	µg/L	<	0.68	<	0.68	0.11	--	--	0.11	--	--	No
2,6-Dinitrotoluene	µg/L	<	0.54	<	0.54	No Criteria	--	--	--	--	--	Uo ⁵
Di-n-Octyl Phthalate	µg/L	<	0.65	<	0.65	No Criteria	--	--	--	--	--	Uo ⁵
1,2-Diphenylhydrazine	µg/L	<	0.33	<	0.33	0.04	--	--	0.040	--	--	No
Fluoranthene	µg/L	<	0.76	<	0.76	300	--	--	300	--	--	No
Fluorene	µg/L	<	0.81	<	0.81	1,300	--	--	1,300	--	--	No
Hexachlorobenzene	µg/L	<	0.89	<	0.89	0.00075	--	--	0.00075	--	1.0	No
Hexachlorobutadiene	µg/L	<	0.84	<	0.84	0.44	--	--	0.44	--	--	No
Hexachlorocyclopentadiene	µg/L	<	0.45	<	0.45	50	--	--	240	--	50	No
Hexachloroethane	µg/L	<	0.58	<	0.58	1.9	--	--	1.9	--	--	No
Indeno(1,2,3-cd)Pyrene	µg/L	<	0.63	<	0.63	0.0044	--	--	0.0044	--	--	No
Isophorone	µg/L	<	0.81	<	0.81	8.4	--	--	8.4	--	--	No
Naphthalene	µg/L	<	0.66	<	0.66	No Criteria	--	--	--	--	--	Uo ⁵
Nitrobenzene	µg/L	<	0.74	<	0.74	17	--	--	17	--	--	No
N-Nitrosodimethylamine	µg/L	<	1.1	<	1.1	0.00069	--	--	0.00069	--	--	No

Constituent	Units	Qualifier	MEC	Qualifier	B	C	CMC	CCC	Water & Org	Org. Only	MCL	RP
N-Nitrosodi-n-Propylamine	µg/L	<	0.85	<	0.85	0.005	--	--	0.0050	--	--	No
N-Nitrosodiphenylamine	µg/L	<	0.9	<	0.9	5	--	--	5.0	--	--	No
Phenanthrene	µg/L	<	0.65	<	0.65	No Criteria	--	--	--	--	--	Uo ⁵
Pyrene	µg/L	<	0.45	<	0.45	960	--	--	960	--	--	No
1,2,4-Trichlorobenzene	µg/L	<	0.59	<	0.59	5	--	--	--	--	5.0	No
Aldrin	µg/L	<	0.002	<	0.002	0.00013	3.0	--	0.00013	--	--	No
alpha-BHC	µg/L	<	0.004	<	0.004	0.0039	--	--	0.0039	--	--	No
beta-BHC	µg/L	<	0.002	<	0.002	0.014	--	--	0.014	--	--	No
gamma-BHC	µg/L	<	0.004	<	0.004	0.019	0.95	--	0.019	--	0.20	No
delta-BHC	µg/L	<	0.002	<	0.002	No Criteria	--	--	--	--	--	Uo ⁵
Chlordane	µg/L	<	0.04	<	0.04	0.00057	2.4	0.0043	0.00057	--	0.10	No
4,4'-DDT	µg/L	<	0.003	<	0.003	0.00059	1.1	0.0010	0.00059	--	--	No
4,4'-DDE	µg/L	<	0.004	<	0.004	0.00059	--	--	0.00059	--	--	No
4,4'-DDD	µg/L	<	0.02	<	0.02	0.00083	--	--	0.00083	--	--	No
Dieldrin	µg/L	<	0.005	<	0.005	0.00014	0.24	0.056	0.00014	--	--	No
alpha-Endosulfan	µg/L	<	0.004	<	0.004	0.056	0.22	0.056	110	--	--	No
beta-Endosulfan	µg/L	<	0.002	<	0.002	0.056	0.22	0.056	110	--	--	No

Constituent	Units	Qualifier	MEC	Qualifier	B	C	CMC	CCC	Water & Org	Org. Only	MCL	RP
Endosulfan Sulfate	µg/L	<	0.02	<	0.02	110	--	--	110	--	--	No
Endrin	µg/L	<	0.002	<	0.002	0.036	0.086	0.036	0.76	--	2.0	No
Endrin Aldehyde	µg/L	<	0.002	<	0.002	0.76	--	--	0.76	--	--	No
Heptachlor	µg/L	<	0.003	<	0.003	0.00021	0.52	0.0038	0.00021	--	0.010	No
Heptachlor Epoxide	µg/L	<	0.009	<	0.009	0.00010	0.52	0.0038	0.00010	--	0.010	No
PCBs sum ⁴	µg/L	<	0.3	<	0.04	0.00017	--	0.014	0.00017	--	0.50	No
Toxaphene	µg/L	<	0.2	<	0.2	0.00020	0.73	0.00020	0.00073	--	3.0	No
1,2-Dibromoethane	µg/L	<	0.005	--	--	0.050	--	--	--	--	0.050	No
2,4,5-TP (Silvex)	µg/L	<	0.5	--	--	50	--	--	--	--	50	No
2,4-D	µg/L	<	0.8	--	--	70	--	--	--	--	70	No
Alachlor	mg/L	<	0.5	--	--	2.0	--	--	--	--	2.0	No
Aluminum, Total	µmhos / cm	=	220	=	580	200	--	--	--	--	200	Yes
Ammonia, Total (as N) (mussels present)	mg/L	<	0.2	<	0.2	0.66	1.8	0.66	--	--	--	No
Ammonia, Total (as N) (mussels absent)	mg/L	<	0.2	<	0.2	1.98	2.0	2.0	--	--	--	No
Atrazine	µg/L	<	0.3	--	--	1.0	1,500	--	--	--	1.0	No
Barium	µg/L	=	47	--	--	1,000	--	--	1,000	--	1,000	No

Constituent	Units	Qualifier	MEC	Qualifier	B	C	CMC	CCC	Water & Org	Org. Only	MCL	RP
Bentazon	µg/L	<	0.4	--	--	18	--	--	--	--	18	No
Carbofuran	µg/L	<	2	--	--	18	--	--	--	--	18	No
Chloride	µg/L	=	23,000	--	--	230,000	860,000	230,000	--	--	250,000	No
cis-1,2-Dichloroethylene	µg/L	<	0.4	--	--	6.0	--	--	--	--	6.0	No
Dalapon	µg/L	<	6.1	--	--	200	--	--	--	--	200	No
Di(2-ethylhexyl)adipate	µg/L	<	0.4	--	--	400	--	--	--	--	400	No
Dibromochloropropane	µg/L	<	0.004	--	--	0.20	--	--	--	--	0.20	No
Dinoseb	µg/L	<	0.8	--	--	7.0	--	--	--	--	7.0	No
Diquat	µg/L	<	3.3	--	--	20	--	--	--	--	20	No
Endothal	µg/L	<	16	--	--	100	--	--	--	--	100	No
Fluoride	µg/L	=	210	--	--	2,000	--	--	--	--	2,000	No
Glyphosate	µg/L	<	3	--	--	700	--	--	--	--	700	No
Methoxychlor	µg/L	<	0.02	--	--	30	--	--	--	--	30	No
Methyl Tert-butyl Ether (MTBE)	µg/L	<	0.5	--	--	13	151,000	51,000	--	--	13	No
Molinate	µg/L	<	0.2	--	--	20	--	--	--	--	20	No
Nitrate, Total (as N)	mg/L	=	8.1	=	0.77	10	--	--	--	--	10	No
Nitrite, Total (as N)	mg/L	=	0.044	--	--	1.0	--	--	--	--	1.0	No
Oxamyl	µg/L	<	0.8	--	--	50	--	--	--	--	50	No

Constituent	Units	Qualifier	MEC	Qualifier	B	C	CMC	CCC	Water & Org	Org. Only	MCL	RP
Perchlorate	µg/L	<	0.9	--	--	6.0	--	--	--	--	6.0	No
Picloram	µg/L	<	0.5	--	--	500	--	--	--	--	500	No
Simazine	µg/L	<	0.3	--	--	4.0	--	--	--	--	4.0	No
Styrene	µg/L	<	0.5	--	--	100	--	--	--	--	100	No
Thiobencarb	µg/L	<	0.2	--	--	70	--	--	--	--	70	No
Total Dissolved Solids (TDS)	mg/L	=	440	=	320	500	--	--	--	--	500	No
Trichlorofluoromethane	µg/L	<	0.5	--	--	150	--	--	--	--	150	No
Trichlorotrifluoroethane	µg/L	<	0.25	--	--	1,200	--	--	--	--	1,200	No
Xylenes	µg/L	<	0.5	--	--	1,750	--	--	--	--	1750	No
Specific Conductance	µmhos/cm	=	715	=	317	900	--	--	--	--	900	No

Table Notes:

1. In accordance with the implementation procedures specified in section IV.D.2.c of the State Water Board's Final *Part 2 of the Water Quality Control Plan for Inland Surface Waters, Enclosed Bays, and Estuaries of California—Tribal and Subsistence Fishing Beneficial Uses and Mercury Provisions* (Statewide Mercury Objectives), this value represents the maximum observed annual average concentration for comparison with the water column concentration.
2. Represents the water column concentration for translation of the fish tissue Water Quality Objective for protection of the COMM, WILD, and RARE beneficial uses applicable to the Russian River, a flowing waterbody, established in the Statewide Mercury Objectives.

Constituent	Units	Qualifier	MEC	Qualifier	B	C	CMC	CCC	Water & Org	Org. Only	MCL	RP
<p>3. Two of 17 effluent samples were analyzed with an analytical method with a reporting limit of 3.0 µg/L. Since 15 effluent samples analyzed with a reporting limit of 0.83 µg/L were below the most stringent water quality objective, a determination of no reasonable potential has been made for bis(2-ethylhexyl)phthalate, as further discussed in Fact Sheet section 4.3.3.3.</p> <p>4. PCBs sum refers to sum of PCB 1016, 1221, 1232, 1242, 1248, 1254, and 1260.</p> <p>5. Uo means that reasonable potential could not be determined.</p>												

ATTACHMENT G - RECYCLED WATER FINDINGS, USE REQUIREMENTS, PROVISIONS, AND TECHNICAL REPORT REQUIREMENTS

The Recycled Water Findings, Use Requirements, Provisions, and Technical Report Requirements in this Attachment apply to the Permittee's recycled water system, including storage, distribution, and use.

1. RECYCLED WATER FINDINGS

The North Coast Regional Water Quality Control Board (Regional Water Board) finds that:

1.1. BACKGROUND INFORMATION

- 1.1.1. "Recycled water" means water which, as a result of treatment of waste, is suitable for a direct beneficial use or a controlled use that would not otherwise occur and is therefore considered a valuable resource. (Wat. Code, § 13050(n).)
- 1.1.2. In 1977, the State Water Board adopted Resolution No. 77-1, *Policy with Respect to Water Reclamation in California* (Resolution No. 77-1). Resolution No. 77-1, in part, encourages the use of recycled water in the state.
- 1.1.3. In 1996, the State Water Board and DDW set forth principles, procedures, and agreements to which the agencies committed themselves, relative to the use of recycled water in California, in a document titled *Memorandum of Agreement between the Department of Health Services and the State Water Resources Control Board on the Use of Reclaimed Water* (MOA). This Order is consistent with the MOA.
- 1.1.4. Prior to July 1, 2014, CDPH provided public health recommendations to the Water Boards through review and approval of title 22 Engineering Reports prepared pursuant to California Code of Regulations, title 22, section 60323. The Water Boards then issue permits. Effective July 1, 2014, the administration of the Drinking Water Program, including responsibility for review of title 22 Engineering Reports was transferred from the CDPH to the State Water Board, Division of Drinking Water.
- 1.1.5. The State Water Board adopted the *Water Quality Control Policy for Recycled Water* (Recycled Water Policy) in 2009 and amended it in 2013 and 2018. The Recycled Water Policy recognizes the fact that some groundwater basins in the state contain salts and nutrients that exceed or threaten to exceed water quality objectives in the applicable Basin Plans, and that not all Basin Plans include adequate implementation procedures for achieving or ensuring compliance with the water quality objectives for salt or nutrients. However, in the absence of an

approved SNMP, the Regional Water Board may impose specific requirements to ensure the preservation and maintenance of high-quality groundwater.

- 1.1.6. On June 3, 2014, the State Water Resources Control Board (State Water Board) adopted Order WQ 2014-0090, Waste Discharge Requirements for Recycled Water Use. On June 7, 2016, the State Water Board adopted Order WQ 2016-0068-DDW, Water Reclamation Requirements for Recycled Water Use (General Order), amending and replacing Order WQ 2014-0090. The General Order was adopted to facilitate recycled water use and reduce demand on potable water supplies and encourages recycled water projects by maintaining a streamlined approach in permitting new recycled water users through a water recycling program. This Order (Order No. R1-2021-0002) incorporates language from the General Order and supports the streamlined approach that allows the Permittee to add recycled water projects through the Permittee's recycled water program and in accordance with requirements of this Order.
- 1.1.7. The Uniform Statewide Recycling Criteria was established for the protection of public health and are codified in the California Code of Regulations, title 22, division 4, chapter 3 (herein referred to as Uniform Statewide Recycling Criteria). Approved uses of recycled water under the Uniform Statewide Recycling Criteria depend on the level of treatment and potential for public contact. Under the Uniform Statewide Recycling Criteria, recycled water is categorized based on treatment levels. There are four categories of recycled water relevant to this Order; they are listed here and defined in the indicated regulations section:
 - 1.1.7.1. Undisinfected secondary recycled water (Cal. Code Regs., tit. 22, § 60301.900.)
 - 1.1.7.2. Disinfected secondary-23 recycled water (Cal. Code Regs., tit. 22, § 60301.225.)
 - 1.1.7.3. Disinfected secondary-2.2 recycled water (Cal. Code Regs., tit. 22, § 60301.220.)
 - 1.1.7.4. Disinfected tertiary recycled water (Cal. Code Regs., tit. 22, § 60301.230.)

An approved title 22 Engineering Report addressing protection of public health is required before authorization to use recycled water is granted by the Regional Water Board Executive Officer.
- 1.1.8. Recycled water shall only be used consistent with the Uniform Statewide Recycling Criteria and requirements specified in this Order, including:

- 1.1.8.1. Written approval of a title 22 Engineering Report prior to delivery of recycled water for all use types proposed by the Permittee;
- 1.1.8.2. Use of recycled water is subject to backflow prevention, cross connection tests, and setback requirements to surface impoundments, wells, etc. as contained in the Uniform Statewide Recycling Criteria and the California Code of Regulations, title 17, division 1, article 2.
- 1.1.9. New uses of recycled water not identified at the time this Order is adopted, may be authorized after Order adoption, if such new uses meet the requirements of this Order and are addressed in a revised title 22 Engineering Report that has been reviewed and accepted by DDW.
- 1.1.10. When used in compliance with the Recycled Water Policy, the Uniform Statewide Recycling Criteria, and all applicable state and federal water quality laws, the Regional Water Board finds that recycled water is safe for approved uses, and strongly supports recycled water as a safe alternative to raw and potable water supplies for approved uses.
- 1.1.11. This Order authorizes beneficial, non-potable recycled water uses consistent with the Uniform Statewide Recycling Criteria and any additional requirements specified in the Permittee's ROWD and approved by DDW.
- 1.1.12. There are many sources of salts and nutrients in surface and groundwater, including leaching of naturally occurring salts in soils as a result of irrigation and precipitation, animal wastes, fertilizers and other soil amendments, municipal use including water softeners, and industrial wastewater.
- 1.1.13. The use of recycled water has the potential to increase nutrients in groundwater supplies. In order to minimize the nutrient loading, this Order requires that recycled water used for irrigation purposes be applied at agronomic rates.
- 1.1.14. The use of recycled water for irrigation has the potential to increase salts and other constituents in groundwater, but is not expected to be a significant source of salt loading relative to other potential sources, particularly when recycled water is used in the same watershed in which it would otherwise be discharged. Basin-specific salt and nutrient management plans, however, will provide definitive information on where assimilative capacity is available.
- 1.1.15. The Recycled Water Policy states that salts and nutrients from all sources must be managed on a basin-wide or watershed-wide basis in a manner that ensures attainment of water quality objectives and protection of beneficial uses. The most effective way to address salt and nutrient loading is typically through the development of regional or subregional salt and nutrient management plans

rather than imposing requirements solely on individual recycled water projects or other individual sources of salts and nutrients.

- 1.1.16. The State and Regional Water Boards assert the need for comprehensive salt and nutrient management planning and direct that salinity and nutrient increases should be managed in a manner consistent with the Recycled Water Policy.
- 1.1.17. To sustain the ongoing development of salt and nutrient management plans in basins where plans are needed and to clarify where salt and nutrient management planning is not needed, each regional water board shall evaluate each basin or subbasin in its region before April 8, 2021 and identify basins through a resolution or executive officer determination where salts and/or nutrients are a threat to water quality and therefore need salt and nutrient management planning to achieve water quality objectives in the long term. Each regional water board shall review and update this evaluation every five years to consider any changes in these factors that have occurred that would change the findings from the initial evaluation.
- 1.1.18. According to Section 7.4 of the Recycled Water Policy, non-potable water projects are not required to conduct project-specific receiving water and groundwater monitoring if criteria specified in the Recycled Water Policy are met (i.e. recycled water is applied in a manner that minimizes percolation of recycled water below the plant root zones, appropriate use of fertilizer that accounts for nutrient levels in the recycled water and nutrient demand by plants), unless otherwise required by an accepted salt and nutrient management plan. In addition, project-specific monitoring may be required if the Regional Water Board determines that there are unique site-specific conditions (i.e., recycled water irrigation over high transmissivity soils over a shallow (5 feet or less) high quality groundwater aquifer, recycled water proposed to be stored in unlined ponds where the Regional Water Board determines that it will result in an unreasonable threat to groundwater quality). This Order requires the Permittee to comply with any future salt and nutrient management plan adopted by the Regional Water Board. This Order requires groundwater monitoring to assess impacts of effluent disposal on a land disposal area that represents the worst-case impacts on groundwater. Further monitoring could be required as needed for development of a salt and nutrient management plan.

- 1.1.19. The Recycled Water Policy (Attachment A) includes monitoring requirements for Constituents of Emerging Concern¹ (CECs) for the use of recycled water for groundwater recharge and reservoir augmentation. The monitoring requirements and criteria for evaluating monitoring results in the Recycled Water Policy are based on recommendations from a Science Advisory Panel². Because this General Order is limited to non-potable uses and does not authorize groundwater recharge or reservoir augmentation activities, monitoring for CECs is not required.
- 1.1.20. This Order requires the Permittee to minimize the potential for surface runoff of recycled water but recognizes that even with diligent implementation of best management practices (BMPs), incidental runoff events may occur on occasion. Incidental runoff is defined as unintended small amounts (volume) of runoff from recycled water use areas where agronomic rates and appropriate best management practices are being implemented. Examples of incidental runoff include unintended, minimal over-spray from sprinklers that escapes the recycled water use area or accidental breakage of a sprinkler head on a properly maintained irrigation system. Water leaving a recycled water use area is not considered incidental if it is part of the facility design, if it is due to excessive application, if it is due to intentional overflow or application, or if it is due to negligence. Incidental runoff events are typically infrequent, low volume, accidental, not due to a pattern of neglect or lack of oversight and are promptly addressed. The Regional Water Board recognizes that such minor violations are unavoidable and present a low risk to water quality. All runoff incidents, including incidental runoff, shall be summarized in the Permittee's annual recycled water monitoring report. Enforcement action shall be considered for runoff that is not incidental, inadequate response by the Permittee to incidental runoff incidents, repeated runoff incidents that were within the Permittee's control, where incidental runoff directly causes violations of water quality objectives, incidents that create a condition of pollution or nuisance, and discharges that reach surface water in violation of Discharge Prohibitions in

¹ For this Policy, CECs are defined to be chemicals in personal care products, pharmaceuticals including antibiotics, antimicrobials; industrial, agricultural, and household chemicals; hormones; food additives; transformation products, inorganic constituents; and nanomaterials.

² The Science Advisory Panel was convened in accordance with provision 10.b of the Recycled Water Policy. The panel's recommendations were presented in the report; *Monitoring Strategies for Chemicals of Emerging Concern (CECs) in Recycled Water - Recommendations of a Science Advisory Panel*, dated June 25, 2010.

section 3 of the Order and/or Recycled Water Requirements in Attachment G, section 2.4.

1.2. STATUTORY AND REGULATORY ISSUES

- 1.2.1. State Water Board DDW requirements for completion of the title 22 Recycled Water Engineering Report were identified in letters dated August 12, 2014 and January 26, 2021 that also included recommendations and conditions of approval that are included within the Order section and below as requirements of this Order:
 - 1.2.1.1. The Permittee shall maintain a current operations plan for the WWTF, which shall be submitted to DDW and Regional Water Board for approval upon any changes or modifications to Facility operations. The Permittee's Facility Operation and Maintenance Manual and/or Standard Operating Procedure documents shall include General Provisions 4.d through 4.g of the January 22, 2021 DDW Conditional Acceptance letter.
 - 1.2.1.2. Per articles 8, 9, and 10 of the Recycled Water Criteria, the Permittee must maintain all required redundancy, reliability and contingency plan elements to ensure proper operation of the Facility at all times.
 - 1.2.1.3. A revised Title 22 Recycled Water Engineering Report must be submitted to DDW and the Regional Water Board for review and approval for any future new uses of recycled water or expansion of irrigated areas beyond those described in the DDW-accepted January 2021 Title 22 Recycled Water Engineering Report.
 - 1.2.1.4. Future recycled water uses(s) for a trucking program will require submittal of an amendment to the January 2021 Title 22 Recycled Water Engineering Report.
- 1.2.2. Pursuant to Water Code section 13523, the Regional Water Board, after consulting with and receiving the recommendation of the State Water Board DDW, may prescribe water reclamation requirements for water that is used or proposed to be used as recycled water. The requirements shall be established in conformance with the Uniform Statewide Recycling Criteria pursuant to Water Code section 13521. Pursuant to Water Code section 13523 (b), the requirements for use of recycled water not addressed by the Uniform Statewide Recycling Criteria will be considered on a case-by-case basis by Regional Water Boards, after consulting with and receiving the recommendations of the State Water Board DDW. The State Water Board DDW provides such recommendations and conditions of approval through acceptance letters for title 22 Engineering Reports.

- 1.2.3. This Order implements Water Code section 13523.1 which authorizes issuance of a Master Recycled Water Permit to suppliers or distributors, or both, of recycled water in lieu of issuing individual water recycled water requirements to each recycled water user.
- 1.2.4. Effluent Limitations included in Order No. R1-2021-0002 will ensure compliance with requirements contained in title 22 and the DDW/State Water Board MOA.
- 1.2.5. Recycled water shall only be used on areas that have been evaluated in compliance with the California Environmental Quality Act (CEQA). Future CEQA documents must evaluate the potential environmental impacts of recycled water use on a proposed use site and identify mitigation measures for the protection of water quality to be implemented. Mitigation measures and BMPs must be clearly identified in the Land Discharge/Recycled Water Operations and Management Plan as required by section 6.3.2.1 of the Order and Attachment G, section 4.5.
- 1.2.6. The uses of recycled water authorized by this Order are exempt from the requirements of Consolidated Regulations for Treatment, Storage, Processing, or Disposal of Solid Waste in California Code of Regulations, title 27, division 2, subdivision 1, section 20005, et seq. The activities are exempt from the requirements of title 27 so long as the activity meets, and continues to meet, all preconditions listed below. (Cal Code Regs., tit. 27, § 20090.)
 - 1.2.6.1. Sewage—Discharges of domestic sewage or treated effluent which are regulated by WDRs issued pursuant to California Code of Regulations, title 23, division 3, chapter 9, or for which WDRs have been waived, and which are consistent with applicable water quality objectives, and treatment or storage facilities associated with municipal wastewater treatment plants, provided that residual sludge or solid waste from wastewater treatment facilities shall be discharged only in accordance with the applicable State Water Board promulgated provisions of this division. (Cal. Code Regs., tit. 27, § 20090(a).)
 - 1.2.6.2. Wastewater—Discharges of wastewater to land, including but not limited to evaporation ponds, percolation ponds, or subsurface leach fields if the following conditions are met: (1) the applicable Regional Water Board has issued WDRs, reclamation requirements, or waived such issuance; (2) the discharge is in compliance with the applicable water quality control plan; and (3) the wastewater does not need to be managed according to, California Code of Regulations, title 22, division 4.5, chapter 11, as a hazardous waste. (Cal. Code Regs., tit. 27, § 20090(b).)
 - 1.2.6.3. Reuse – Recycling or other use of materials salvaged from waste or produced by waste treatment, such as scrap metal, compost, and recycled chemicals, provided that discharges of residual wastes from recycling or treatment

operations to land shall be according to applicable provisions of Title 27 regulations.(Cal. Code Regs., tit. 27, § 20090(h).)

- 1.2.7. Pursuant to Water Code section 106.5, it is the policy of the State of California that every human being has the right to safe, clean, affordable, and accessible water adequate for human consumption, cooking, and sanitary purposes. This Order promotes that policy by encouraging uses of recycled water. Such uses must be consistent with the requirements of California Code of Regulations (including the Uniform Statewide Recycling Criteria). This Order furthers the human right to water by encouraging use of recycled water, thus reducing demand on other sources, including use of potable water used for non-potable uses where recycled water is available.
- 1.2.8. The Regional Water Board consulted with DDW, the Sonoma County Health Department, and the Marin Sonoma Mosquito and Vector Control District and considered any recommendations regarding public health aspects for this use of recycled water.

2. RECYCLED WATER USE REQUIREMENTS

- 2.1. The delivery of recycled water shall cease as soon as possible if:
 - 2.1.1. Disinfection of wastewater ceases at any time; or
 - 2.1.2. Recycled water specifications are violated or threaten to be violated.
- 2.2. The use of recycled water shall not result in unreasonable waste of water.
- 2.3. The use of recycled water shall not create a condition of pollution or nuisance as defined in Water Code section 13050(m).
- 2.4. The incidental runoff of recycled water shall not result in water quality less than that prescribed in water quality control plans or policies unless authorized through time schedule provisions in WDRs, waivers of WDRs, or conditional prohibitions regulating agricultural discharges from irrigated lands.
- 2.5. All recycled water provided pursuant to this Order shall be treated and managed in conformance with all applicable provisions of the Recycled Water Policy.
- 2.6. The Permittee shall be responsible for ensuring that recycled water meets the quality standards of sections 4.3 and 4.4 of the Order and that all users of recycled water comply with the terms and conditions of this Order and with any rules, ordinances, or regulations adopted by the Permittee.
- 2.7. The Permittee shall discontinue delivery of recycled water during any period in which there is reason to believe that the quality of the delivered recycled water is

not meeting the Uniform Statewide Recycling Criteria and any other requirements specified in this Order. Notification requirements are as follows:

- 2.7.1. The Permittee shall notify recycled water users if recycled water that does not meet the recycled water quality requirements of this Order is released into the recycled water system.
- 2.7.2. The Permittee shall notify the Regional Water Board and State Water Board DDW within one (1) business day of determining that delivery of off-specification recycled water has taken place.
- 2.7.3. In circumstances where the emergency requires termination of delivery to recycled water users, the Permittee shall copy the Regional Water Board and State Water Board DDW on any correspondence concerning non-compliance between the Permittee and its users. This notification does not supersede any notification requirements contained in Order Provision 6.1.2.2 and Attachment D section 5.5.
- 2.7.4. The delivery of recycled water shall not resume until all conditions have been corrected.
- 2.8. The Permittee shall require each recycled water user to report all violations of recycled water regulations identified in this Order, including runoff incidents. All reported violations of recycled water regulations shall be included in the Permittee's annual recycled water report, including incidental runoff events that the Permittee is aware of.
- 2.9. Uses of recycled water with frequent or routine application (i.e., agricultural or landscape irrigation uses) shall be at agronomic rates and shall consider soil, climate, and plant demand. In addition, application of recycled water and use of fertilizers shall be at a rate that takes into consideration nutrient levels in recycled water and nutrient demand by plants. The Permittee is required to maintain and update its Land Discharge/Recycled Water Operations and Management Plan specifying agronomic rates and nutrient application for the use area(s) and a set of reasonably practicable measures to ensure compliance with the General Order.
 - 2.9.1. Hydraulic loading to any individual recycled water use site shall be at reasonable agronomic rates designed to minimize percolation of wastewater constituents below the evaporative and root zone.
 - 2.9.2. The Permittee must communicate to recycled water users the nutrient levels in the recycled water at least monthly during the irrigation season so that the recycled water users can appropriately evaluate fertilizer needs prior to application of fertilizers. If the Permittee demonstrates that the recycled water nutrient concentrations are low and consistent from month to month, then the

Permittee may reduce the frequency of notifications upon approval by the Regional Water Board Executive Officer.

- 2.10. Uses of recycled water that are infrequent (i.e., dust control, frost protection, firefighting, hydrostatic testing, etc.) shall be addressed by a set of reasonably practicable measures within an Implementation or Operations and Management Plan.
- 2.11. Recycled water shall not be applied on water-saturated or frozen ground or during periods of precipitation such that runoff is induced.
- 2.12. Recycled water shall not be allowed to escape the recycled use area(s) as surface flow that could either pond and/or enter surface waters. [CCR title 22, section 60310(e)] However, incidental runoff of recycled water, such as unintended, minimal over-spray from sprinklers that escapes the recycled water use area, or accidental breakage of a sprinkler head on a properly maintained irrigation system, is not a violation of this Order. Practices and strategies to prevent the occurrence of runoff shall include, where appropriate, but not be limited to:
 - 2.12.1. All new recycled water use sites shall include a 100-foot setback to all surface waters or provide written documentation of appropriate best management practices that will be implemented in order to prevent or minimize the potential for runoff discharging to surface water;
 - 2.12.2. Urban recycled water use sites shall maintain appropriate setbacks to the street gutter and other inlets to the storm drain system based on site conditions or implement alternative means to prevent the discharge of runoff to surface waters.
 - 2.12.3. Implementation of an Operations and Maintenance Plan that provides for detection of leaks (for example, from sprinkler heads), and correction within 72 hours of learning of the runoff, or prior to the release of 1,000 gallons, whichever comes first.
 - 2.12.4. Proper design and aim of sprinkler heads;
 - 2.12.5. Proper design and operation of the irrigation system;
 - 2.12.6. Refraining from application during precipitation events;
 - 2.12.7. Application of recycled water at an agronomic rate that does not exceed the water or nutrient demand of the crop or vegetation being irrigated;
 - 2.12.8. Use of repeat start times and multiple water days to increase irrigation efficiency and reduce runoff potential;

- 2.12.9. Maintenance of recycled water infrastructure (pipelines, pumps, etc.) to prevent and minimize breakage and leaks; and
- 2.12.10. Adequate protection of all recycled water reservoirs and ponds against overflow, structural damage, or a reduction in efficiency resulting from a 25-year, 24-hour storm or flood event or greater, and notification of the Regional Water Board Executive Officer, if a discharge occurs.
- 2.13. Use areas that are spray irrigated and allow public access shall be irrigated during periods of minimal use. Consideration shall be given to allow maximum drying time prior to subsequent public use.
- 2.14. Direct or windblown spray, mist, or runoff from irrigation areas shall not enter dwellings, designated outdoor eating areas, or food handling facilities, roadways, or any other area where the public would be accidentally exposed to recycled water. [CCR title 22, section 60310(e)(3)]
- 2.15. Drinking water fountains shall be protected against contact with recycled water spray, mist, or runoff. [CCR title 22, section 60310(e)(3)]
- 2.16. All recycled water equipment, pumps, piping, valves, and outlets shall be appropriately marked to differentiate them from potable facilities.
- 2.17. The Permittee shall implement the requirements of the California Health and Safety Code (CHSC), section 116815 regarding the installation of purple pipe. CHSC section 116815 requires that "*all pipes installed above or below the ground, on or after June 1, 1993, that are designed to carry recycled water, shall be colored purple or distinctively wrapped with purple tape.*" Section 116815 also contains exemptions that apply to municipal facilities that have established a labeling or marking system for recycled water used on their premises and for water delivered for agricultural use. The Permittee shall document compliance with this requirement on an annual basis in its annual monitoring report. The Permittee shall continue to implement the requirements of CHSC section 116815 during the term of this Order.
- 2.18. No physical connection can be made or allowed to exist between the recycled water system and any separate system conveying potable water. If swivel-ell device is planned to be used, the construction plan must be submitted to DDW and the Regional Water Board for review and approval.
- 2.19. The portions of the recycled water piping system that are in areas subject to access by the general public shall not include any hose bibbs. Only quick couplers that differ from those used on the potable water system shall be used on the portions of the recycled water piping system in areas subject to public access. [CCR title 22, section 60310(l)]

- 2.20. There shall be no cross-connection between potable water supply and piping containing recycled water. [22 CCR, section 60310(h)] All users of recycled water shall provide for appropriate backflow protection for potable water supplies as specified in California Code of Regulations, title 17, section 7604 or as determined by the State Water Board on a case-by- case basis to protect public health.
- 2.21. Disinfected tertiary recycled water shall not be irrigated within 50 feet of any domestic water supply well or domestic water supply surface intake, unless the technical requirements specified in CCR title 22, section 60310(a) have been met and approved by DDW.
- 2.22. The use of recycled water shall not cause degradation of any water supply.
- 2.23. Areas irrigated with recycled water shall be managed to minimize ponding and conditions conducive to the proliferation of mosquitoes and other disease vectors, and to avoid creation of a public nuisance or health hazard. Irrigation water shall infiltrate completely within a 24-hour period.
- 2.24. All areas where recycled water is used that are accessible to the public shall be posted with signs that are visible to the public, in a size no less than 4 inches high by 8 inches wide that include the following wording: 'RECYCLED WATER – DO NOT DRINK'. [CCR title 22, section 60310(g)] Each sign shall display an international symbol similar to that shown in CCR title 22, Figure 60310-A. These warning signs shall be posted at least every 500 feet with a minimum of a sign at each corner and access road. DDW may accept alternative signage and wording, or an educational program, provided that applicant demonstrates to DDW that the alternative approach will assure an equivalent degree of public notification.
- 2.25. The California Waterworks Standards (California Code of Regulations (CCR), Title 22, Division 4, Chapter 16, Section 64572) establish criteria for the separation of new water mains from non-potable pipelines. The following distances shall be met, whenever feasible, for all new construction:
- 2.25.1 New water mains and new supply lines shall not be installed in the same trench as and shall be at least 10 feet horizontally from and one foot vertically above, any parallel pipeline conveying disinfected tertiary recycled water.
- 2.25.2 DDW recognizes that certain conditions may call for the installation of pipelines with less separation distance than what is required by the regulations. In these situations, the water system may propose an alternative pursuant to CCR, Title 22, Section 64551.100 which states: "(a) A water system that proposes to use an alternative to a requirement in this chapter shall: (1) Demonstrate to the State Board that the proposed alternative would provide at least the same level

of protection to public health; and (2) Obtain written approval from the State Board prior to implementation of the alternative.”

- 2.26. A minimum freeboard, consistent with pond design, but not less than 2 feet, shall be maintained under normal operating conditions in any reservoir or pond containing recycled water. When extraordinary operating conditions necessitate a freeboard of less than 2 feet, the Permittee will document the variance in the monthly self-monitoring report. The report will include an explanation of the circumstances under which the variance is required, the estimated minimum freeboard during the extraordinary period, and any permit violations occurring as a result of the variance.
- 2.27. The use of recycled water for dust suppression shall only occur during periods of dry weather, shall be limited to periods of short duration, and shall be limited to areas under the control of the Permittee.
- 2.28. The Permittee shall comply with any salt and nutrient management plan that is adopted by the Regional Water Board in the future.

3. RECYCLED WATER PROVISIONS

- 3.1. The Permittee shall manage recycled water, and shall develop, establish and enforce administrative procedures, engineering standards, rules, ordinances and/or regulations governing the design and construction of recycled water systems and use facilities and the use of recycled water in accordance with the criteria established in CCR title 22 and this Order. The Permittee shall develop user agreements requiring user compliance with CCR title 22 and this Order. Recycled water engineering standards, rules, ordinances and/or regulations shall be approved by the Regional Water Board Executive Officer and DDW.

Upon approval of the Permittee’s procedures, engineering standards, rules, ordinances, and/or regulations, the Permittee may authorize specific additional recycled water projects, in accordance with the approved program and agreements and in accordance with the technical report requirements in section 4 of this attachment (Attachment G).

- 3.2. The Permittee shall conduct periodic inspections of the recycled water use areas, facilities, and operations to monitor and assure compliance with the conditions of this Order. The Permittee shall take whatever actions are necessary, including termination of delivery of recycled water, to correct any user violations.
- 3.3. Where dual-plumbed systems are utilized, the Permittee shall, upon prior notification to the user, conduct regular inspections to assure cross-connections are not made with potable water systems and DDW-approved backflow prevention devices are installed and operable. Reports of testing and

maintenance shall be maintained by the Permittee. The Permittee may use a third-party agent to perform cross-connection testing, however, the Permittee is solely responsible for compliance with conditions of this Order and the approved water recycling program.

- 3.4. The Permittee shall be responsible for ensuring that recycled water meets the quality standards of this Order and for the operation and maintenance of transport facilities and associated appurtenances. If an entity other than the Permittee has actual physical and ownership control over the recycled water transport facilities, the Permittee may delegate operation and maintenance responsibilities for such facilities to that entity through use agreements. The Permittee shall require the use of the recycled water to be in accordance with the Uniform Statewide Recycling Criteria and to comply with all requirements of this Order, including requirements to apply only at agronomic rates and not cause unauthorized degradation, pollution, or nuisance. If not the same entity, the Permittee shall provide water quality data and communicate to recycled water users the nutrient levels in the recycled water.
- 3.5. All persons involved in the operation and/or maintenance of the recycled water system shall attend training regarding the safe and efficient operation of recycled water use facilities.
- 3.6. The Permittee shall require recycled water users to comply with the Permittee's use area conditions. Use area requirements shall be consistent with requirements identified in this Attachment (Attachment G).
- 3.7. If recycled water will be transported by truck for uses consistent with the Uniform Statewide Recycling Criteria such as dust control, the Permittee shall provide notification and control measures for Users consistent with the provisions of the approved title 22 Engineering Report that addresses protection of public health.
- 3.8. A copy of the Water Recycling Use Permit must be provided to recycled water users by the Permittee (electronic format is acceptable). The recycled water users must have the documents available for inspection by State and Regional Water Board staff, State/County officials, and/or the Permittee.
- 3.9. The Permittee shall comply with the recycled water monitoring and reporting requirements in Attachment E of this Order. This monitoring program shall be consistent with any applicable Salt and Nutrient Management Plan for the basin/sub-basin. The Permittee is responsible for collecting reports from the recycled water users. Where applicable, recycled water users are responsible for submitting on-site observation reports and use data to the Permittee, who will compile and file an annual report with the Regional Water Board. The Permittee, at its discretion, may assume any of its recycled water users' responsibility for on-site observation reports and use data.

- 3.10. The Permittee and Users shall maintain in good working order and operate as efficiently as possible any facility or control system to achieve compliance with this Order. The Permittee may use a third-party agent to perform this task, however, the Permittee is solely responsible for compliance with conditions of this permit and the approved water recycling program.
- 3.11. The Permittee shall require that personnel receive training to assure proper operation of recycling facilities, worker protection, and compliance with this Order. The Permittee shall require Recycled Water Supervisor(s) to be familiar with the conditions in this Order that apply to recycled water. The Recycled Water Use Supervisor(s) shall have authority to ensure recycled water use complies with this Order and the Uniform Statewide Recycling Criteria.
- 3.12. The Permittee shall assure that all above ground equipment, including pumps, piping, storage reservoir, and valves which may at any time contain recycled water are identified with appropriate notification as required by the Uniform Statewide Recycling Criteria and California Health and Safety Code section 116815. The Permittee may use a third-party agent to perform this task, however, the Permittee is solely responsible for compliance with conditions of this permit and the approved water recycling program.
- 3.13. If, in the opinion of the Regional Water Board Executive Officer, recycled water use at proposed new locations cannot be adequately regulated under the Master Recycled Water Permit, a Report of Waste Discharge may be requested and individual Recycled Water Requirements may be adopted.
- 3.14. If the Permittee delivers recycled water to any dual-plumbed recycled water system(s), the Permittee shall notify DDW and the Regional Water Board of any incidents of backflow from the dual-plumbed recycled water system into the potable water system within 24 hours of the discovery of the incident.
- 3.15. If the Permittee delivers recycled water to any dual-plumbed recycled water system(s), any backflow prevention device installed to protect the public water system serving the dual-plumbed recycled water system shall be inspected and maintained in accordance with section 7605 of title 17, CCR.
- 3.16. Future dual-plumbed use areas shall comply with the following requirements:
 - 3.16.1. Prior to the initial operation of the dual-plumbed recycled water system, the Permittee shall document that there are no cross-connections on-site within the proposed dual-plumbed use area. A description of how the initial separation (cross-connection) test will be performed (pressure, dye, or other method) shall be provided to DDW. The dual-plumbed recycled water system shall be retested for possible cross-connection at least once every four years.

- 3.16.2. The Permittee shall notify DDW prior to conducting the cross-connection control test. DDW staff may witness the test.
- 3.16.3. Provide documentation to describe the method for cross-connection testing (pressure, dye, or other method) and the steps to be taken during the cross-connection control test.
- 3.16.4. Annually thereafter, the Permittee shall ensure that the recycled water system (indoor and outdoor) is inspected for possible cross-connection with the potable water system.
- 3.16.5. The inspectors and the testing shall be performed by a cross-connection control specialist certified by the California-Nevada section of the American Water Works Association or an organization with equivalent certification requirements. Please identify that person in a notification provided to DDW
- 3.16.6. Each dual-plumbed use area must have an adequately trained use area supervisor in order to control the on-site piping and prevent any cross-connections. The use area supervisor must keep as-built plans up to date and on the site.
- 3.16.7. The use area supervisor must be adequately trained on the use of recycled water. The use area supervisor must complete the training before recycled water is delivered.
- 3.16.8. Verify that appropriate backflow prevention devices are installed and have been tested annually in accordance with California Code of Regulations Title 17. Devices must be located on the potable water line, downstream of the meter.
- 3.16.9. The results of the cross-connection inspections and tests must be documented and submitted to DDW.
- 3.16.10. Indicate whether any proposed dual-plumbed use area will receive supplemental water and provide details of properly designed air gap.

4. RECYCLED WATER TECHNICAL REPORT REQUIREMENTS

The Permittee shall maintain up-to-date recycled water technical reports, as follows:

- 4.1. The Permittee shall submit and maintain a DDW-approved title 22 Recycled Water Engineering Report that demonstrates and defines compliance with the Uniform Statewide Recycling Criteria (and any future amendments thereto);
- 4.2. The Permittee shall submit revised and/or additional engineering report(s) to the Regional Water Board and DDW, prior to initiating any recycled water use (e.g., new industrial use, recreational surface impoundments, water cooling, new dual-plumbed system, etc.) not addressed in any previously submitted CCR title 22 engineering report(s). The Permittee shall also submit any approval letters prepared by DDW to the Regional Water Board Executive Officer. Engineering report(s) shall be prepared by a properly qualified engineer registered in California and experienced in the field of wastewater treatment, and shall contain (1) a description of the design of the recycled water system; (2) a contingency plan which will assure that no untreated or inadequately treated wastewater will be delivered to the use areas; and (3) a cross-connection control program (title 17 of the CCR) where a dual-plumbed system is used. Engineering reports shall clearly indicate the means for compliance with CCR title 22 regulations and this Order.
- 4.3. Recycled Water use sites shut down tests must be performed every four years and reuse site inspections must be performed annually. Each must be monitored by the County DEH or DDW. The inspections and testing must be performed by a cross connection control specialist certified by the California-Nevada section of the American Water Works Association or an organization with equivalent certification requirements. A written report documenting the result of the inspection or testing for the prior year must be submitted to the County DEH and DDW within 30 days following completion of the inspection or testing.
- 4.4. Prior to the initial operation of any dual-plumbed recycled water system, and annually thereafter, the Permittee shall ensure that the dual-plumbed system within each facility and use area is inspected for possible cross connections with the potable water system. The recycled water system shall also be tested for possible cross connections at least once every four years. The testing shall be conducted in accordance with the method described in the Engineering Report. The inspections and the testing shall be performed by a cross connection control specialist certified by the California-Nevada section of the American Water Works Association or an organization with equivalent certification requirements. A written report documenting the result of the inspection or testing for the prior year shall be submitted to DDW and the Regional Water Board by March 1 of each year. [CCR title 22, section 60316]

- 4.5. The Permittee shall submit and maintain an up-to-date Land Discharge/Recycled Water Operation and Management Plan that includes the following:
 - 4.5.1. A list of all recycled water users receiving or proposing to receive recycled water, the type of use for each user, the acreage and estimated amount of recycled water use at each use site; the method(s) of conveyance to each user; name(s) of the Recycled Water Use Supervisor at each use site, and maps of each use area.
 - 4.5.1.1. Attachment G-1 of this Order provides a list of existing recycled water use sites; and
 - 4.5.1.2. Attachment G-1 will be updated by the Regional Water Board Executive Officer to include new use sites if and when the Permittee submits the required CEQA and technical information for proposed new use sites and receives approval from the Regional Water Board Executive Officer.
 - 4.5.2. For uses with frequent or routine application (such as irrigation), the Plan shall specify hydraulic and nutrient agronomic rates and demonstrate that the use areas will not exceed these rates and identify BMPs that are protective of groundwater and surface water quality and human health. At a minimum, the Permittee shall implement the required BMPs identified in Attachment G section 2.12 and implement other BMPs as appropriate.
 - 4.5.3. For uses with infrequent or non-routine applications (such as frost protection), the Plan shall specify a list of practices to ensure compliance with this Order.
 - 4.5.4. The Plan may include a water and nutrient budget for use area(s), use area supervisor training, periodic inspections, or other appropriate measures.
 - 4.5.5. The Plan shall include a description of the recycled water operations and maintenance program, including a description of maintenance of equipment and emergency backup systems to maintain compliance with the use area requirements of this Order.
 - 4.5.6. The Plan shall include emergency procedures and notification.
- 4.6. The Permittee shall submit and maintain a Land Discharge/ Recycled Water Operations and Management Plan that includes:
 - 4.6.1. A full description of the Permittee's water recycling program, including:
 - 4.6.1.1. Description of the Permittee's authority, rules, and/or regulations;
 - 4.6.1.2. Design and implementation of the recycled water program;

- 4.6.1.3. Cross-connection testing responsibilities and procedures;
 - 4.6.1.4. Monitoring and reporting program (MRP), if different from the MRP specified in this Order;
 - 4.6.1.5. Recycled water use area inspection program;
 - 4.6.1.6. Compliance program;
 - 4.5.1.7. The Permittee's training program for its employees and use area supervisors; and
 - 4.6.1.8. Methods used to document that recycled water program procedures are followed (i.e., documentation of cross-connection testing, inspections, and employee and user training).
- 4.6.2. A description of the organization and responsibilities of pertinent personnel involved in the water recycling program, including:
- 4.6.2.1. Organizational chart;
 - 4.6.2.2. The name(s), title(s), and phone number(s) of contact person(s) who are charged with operation/oversight of the water recycling program, including the Permittee's recycled water staff and identification of Recycled Water Use Supervisors at each use site;
 - 4.6.2.3. Identification of all agencies or entities involved in the production, distribution, and use of recycled water;
 - 4.6.2.4. A description of legal arrangements, such as, but not limited to, charters, agreements, or Memorandum of Understanding, and inclusion of such legal documents.

Attachment G-1 – Approved Recycled Water Use Sites

The recycled water use site identified in the table below and in Attachment B, Figure B-3 of the Order is an approved recycled water use site.

Customer	APN	Type of Use/Irrigation Types	Total Site Acreage/Irrigated Acreage	Volume of Recycled Water
Northwood Golf Course	094-180-016	Turf Irrigation	26	Varies ¹

Table Notes:

1. Average irrigation volume between 2015 and 2020. The annual recycled water volume applied ranged from 52 to 59 acre-feet.