



Los Angeles Regional Water Quality Control Board

April 17, 2020

Mr. Glenn Shephard
Director of Ventura County Watershed Protection District
800 South Victoria Avenue
Ventura, CA 93009

REVISED COVERAGE UNDER GENERAL NATIONAL POLLUTANT DISCHARGE ELIMINATION SYSTEM AND WASTE DISCHARGE REQUIREMENTS FOR VENTURA COUNTY WATERSHED PROTECTION DISTRICT, ARROYO SIMI SOUTH BANK RESTORATION PROJECT UPSTREAM OF MODERA ROAD AND ARROYO SIMI DOWNSTREAM OF SYCAMORE ROAD, 800 SOUTH VICTORIA AVENUE, VENTURA, CA (ORDER NO. R4-2018-0125, NPDES NO. CAG994004, CI-10534)

Dear Mr. Shephard:

Discharge of groundwater generated from the above-referenced facility is currently regulated under the National Pollutant Discharge Elimination System (NPDES) Permit No. CAG994004, Order No. R4-2018-0125, adopted by the Board on September 13, 2018. The project was enrolled under this general NPDES permit on February 11, 2020. On February 13, 2020 Ventura County Watershed Protection District requested revision to its enrollment under the General Permit to include an additional discharge point for the project. Staff has reviewed your request and revised the enrollment to reflect the additional discharge point.

Enclosed are your Waste Discharge Requirements, which also serve as your NPDES permit, consisting of Order No. R4-2018-0125 and Monitoring and Reporting Program No. CI-10534. The discharge limitations in Part V.A.1 Tables 1, 21, 22, 23, 24, 26 and Receiving Water Limitations in Part VI.A.3 Table 30 of Order No. R4-2018-0125 for the specific constituents listed on Tables A.2. through A.8. of the Fact Sheet are the applicable limitations. Because the groundwater discharge from the project is considered a Creekside construction dewatering operation, the mineral limitations in Attachment B of Order No. R4-2018-0125 are not applicable to your discharge except for nitrogen compounds. All other parts of the Order apply, including but not limited to narrative and receiving water limitations. No later than three days prior to initiation of discharge, you must notify Ventura County Watershed Protection District via email to: discharge.alert@ventura.org about the discharge. Prior to starting discharge, a

IRMA MUÑOZ, CHAIR | RENEE PURDY, EXECUTIVE OFFICER

representative sample of the effluent shall be obtained and analyzed to determine compliance with the discharge limitations.

The Monitoring and Reporting Program requires you to implement the monitoring program on the effective date of coverage under this permit. All monitoring reports should be sent to the Regional Board, electronically by e-mail to (losangeles@waterboards.ca.gov). When submitting monitoring or technical reports to the Regional Board per these requirements, please include a reference to "Compliance File No. CI-10534 and NPDES No. CAG994004", which will assure that the reports are directed to the appropriate file and staff. Also, please do not combine other reports with your monitoring reports. Submit each type of report as a separate document.

The Regional Board is implementing a paperless office system to reduce paper use, increase efficiency and provide a more effective way for our staff, the public and interested parties to view water quality documents. Therefore, please convert all regulatory documents, submissions, data and correspondence that you would normally submit to us as hard copies to a searchable Portable Document Format (PDF). Documents that are less than 10 MB should be emailed to losangeles@waterboards.ca.gov. Documents that are 10 MB or larger should be transferred to a disk and mailed to the Los Angeles Regional Board listed in section X.B.5.c of the attached Monitoring and Reporting Program. If you need additional information regarding electronic submittal of documents, please visit the Regional Board's website listed above and navigate to Paperless Office.

To avoid paying future annual fees, please submit a written request for termination of your enrollment under the general permit in a separate letter, when the project has been completed and the permit is no longer needed.

We are sending a copy of Order No. R4-2018-0125 by email only to you and other parties on the mailing list listed below. A paper copy of the Order will be furnished to anyone who requests it, or it can be obtained at our web site address: http://www.waterboards.ca.gov/losangeles/board_decisions/adopted_orders/.

If you have any questions, please contact Namiraj Jain at 213-620-6003 or e-mail at namiraj.jain@waterboards.ca.gov.

Sincerely,

Renee Purdy
Executive Officer

Enclosures:

Fact Sheet
Monitoring and Reporting Program No. CI-10534
General NPDES No. CAG994004, Order No. R4-2018-0125

cc:

Environmental Protection Agency, Region 9, Permit Section (WTR-5)
U.S. Army Corps of Engineers
U.S. Fish and Wildlife Services, Division of Ecological Services
NOAA, National Marine Fisheries Service
California Department of Fish and Wildlife
Ventura County, Department of Public Works, Environmental Program Division
Ventura County, Department of Public Works, Flood Control Division
Ventura County, Department of Health Services
icis-npdes@pgenv.com, PG Environmental
James Ashby, PG Environmental
Sarah Torres, PG Environmental

**STATE OF CALIFORNIA
CALIFORNIA REGIONAL WATER QUALITY CONTROL BOARD
LOS ANGELES REGION
320 West 4th Street, Suite 200, Los Angeles, California 90013**

**Revised Fact Sheet
WASTE DISCHARGE REQUIREMENTS**

For

**VENTURA COUNTY WATERSHED PROTECTION DISTRICT
(ARROYO SIMI SOUTH BANK UPSTREAM OF MODERA ROAD
AND ARROYO SIMI DOWNSTREAM OF SYCAMORE ROAD RESTORATION
PROJECT)
(Order No. R4-2018-0125, Series 051)
NPDES No. CAG994004
CI-10534**

Project Location Address

1. Arroyo Simi South Bank District's Access Road
Simi Valley, CA 93065
2. Arroyo Simi Downstream of Sycamore Road
Simi Valley, CA 93065

Facility Mailing Address

800 Victoria Avenue
Upland, CA 91786

Project Description

Ventura County Watershed Protection District (Discharger), proposes to discharge groundwater generated during construction and restoration of 50 linear feet of riprap bank and toedown of the Arroyo Simi Creek segment located along South Bank District's Access Road in the City of Simi Valley. In addition, 30 linear feet of riprap splash pool and filter material blankets will be installed immediately downstream of the grade stabilizer to prevent further scouring and invert degradation of its hydraulic structure. Arroyo Simi is a tributary to the Calleguas Creek. The groundwater pumped from the site is passed through a settling tank, Organic Clay, Virgin Carbon and Resin Tank to treat for heavy metals and organics in the groundwater. The treated groundwater will be discharged to Arroyo Simi. The bank restoration construction project in the riverbed is considered a Creekside construction dewatering operation. Hydraulic connection exists between the creek flows and the groundwater beneath the site. Therefore, the mineral effluent limitations do not apply to these discharges except for nitrogen compounds. The site location map and treatment schematic are shown in Figure 1 and Figure 2 respectively.

On February 11, 2020 the project was enrolled under this general NPDES permit No. CAG994004, Order No. R4-2018-0125. On February 13, 2020 Ventura County Watershed Protection District requested a revision to its enrollment under the General Permit to include an additional discharge point located at Arroyo Simi Downstream of Sycamore Road for extension of the project. The additional extension work is necessary to repair a damaged section on the grade stabilizer 2.5 miles from the current project location on Arroyo Simi. The new repair location will need to be dewatered and cavity filled with grout. Staff has reviewed the request and revised the enrollment to reflect the revised treatment schematic with resin tank and additional discharge point.

The authorization to discharge under the general NPDES permit will be effective for the duration of the construction project. If discharge to surface water is necessary after the construction is complete, the discharger must submit a new Notice of Intent (NOI) to the Regional Board for the continuing enrollment under the general NPDES permit for dewatering discharge from the facility.

Volume and Description of Discharge

A proposed maximum of 400,000 gallons per day (gpd) of treated groundwater will be discharged to the Arroyo Simi from Discharge Points M-001 and Point M-002. The groundwater discharge flows into Arroyo Simi, a tributary to Calleguas Creek, a water of the United States.

Table A.1.

Discharge Point	Discharge Location	Latitude	Longitude
M-001	Arroyo Simi South Bank Access Road	N 34° 16' 23",	W 118° 47' 13"
M-002	Arroyo Simi Downstream of Sycamore Road	N 34° 15' 55",	W 118° 45' 2.71"

Applicable Effluent Limitations

Based on the information provided in the NPDES Application Supplemental Requirements, the Regional Board has determined that the constituents listed in Tables A.2. through A.8. below show reasonable potential to exist in the discharge. Therefore, the effluent limitations in Part V.A.1. Tables 1, 21, 22, 23, 24, 26 and Receiving Water Limitations¹ in Part VI.A.3. Table 30 of Order No. R4-2018-0125 for the specific constituents listed on Tables A.2., through A.8. of the Fact Sheet are the applicable limitations. Because the groundwater discharge from the project is considered a Creekside construction dewatering operation, the mineral limitations in Attachment B of Order No. R4-2018-0125 are not applicable to the discharge except for nitrogen

¹ While these limitations are identified as receiving water limitations in Order R4-2018-0125, they are applied as effluent limitations for enrollees because there are no receiving water monitoring requirements for enrollees in the General Order.

compounds. The Discharger must comply with all other parts of the Order, including, but not limited to, narrative effluent and receiving water limitations. The Discharger is required to comply with the following effluent limitations during its enrollment under Order No. R4-2018-0125.

Table A.2.

Constituents	Units	Maximum Daily Limitations	Average Monthly Limitations
Total Suspended Solids	mg/L	75	50
Turbidity	NTU	150	50
BOD ₅ 20°C	mg/L	30	20
Oil and Grease	mg/L	15	10
Settleable Solids	ml/L	0.3	0.1
Sulfides	mg/L	1.0	Not Applicable (NA)
Phenols	mg/L	1.0	NA
Residual Chlorine	mg/L	0.1	NA
Methylene Blue Active Substance (MBAS)	mg/L	0.5	NA
Nitrogen (Nitrate-nitrogen + Nitrite-nitrogen)	mg/L	10	NA
Selenium TR	µg/L	8	4
Benzo (a) Pyrene	µg/L	0.098	0.049
Benzo (b) Fluoranthene	µg/L	0.098	0.049
Chrysene	µg/L	0.098	0.049
Perchlorate	µg/L	6	NA
2,3,7,8-TCDD (Dioxin)	µg/L	0.000000028	0.000000014
Total Petroleum Hydrocarbons (TPH)	µg/L	100	NA

Table A.3. Calleguas Creek Watershed Toxicity TMDL

Constituents	Units	Maximum Daily Limitations	Average Monthly Limitations
Chlorpyrifos	µg/L	0.025	0.014

Constituents	Units	Maximum Daily Limitations	Average Monthly Limitations
Diazinon	µg/L	0.10	0.05

Table A.4. Calleguas Creek Organochlorine Pesticides, Polychlorinated Biphenyls, TMDL

Constituents	Units	Maximum Daily Limitations	Average Monthly Limitations
Chlordane	ng/L	1.2	0.59
4,4-DDD	ng/L	1.7	0.84
4,4-DDE	ng/L	1.2	0.59
4,4-DDT	ng/L	1.2	0.59
Dieldrin	ng/L	0.28	0.14
PCBs	ng/L	0.34	0.17
Toxaphene	ng/L	0.33	0.16

Table A.5. Calleguas Creek and Its Tributaries Toxicity TMDL

Constituents	Units	Effluent Limitations
Toxicity	Toxicity Unit (TUc)	1

Table A.6. Calleguas Creek Watershed Metal- Mercury TMDL WLAs – Dry and Wet Weather

Constituents	Units	Maximum Daily Limitations	Average Monthly Limitations
Mercury	µg/L	0.1	0.051

Table A.7. Calleguas Creek Watershed Metals and Selenium TMDL WLAs –Wet Weather²

² For purposes of this General Permit, discharges occurring from November 15th through April 14th are considered wet weather discharges. No TMDL has been established for dry weather discharges for Arroyo Simi.

Constituents	Units	Maximum Daily Limitations	Average Monthly Limitations
Copper	µg/L	31	15
Nickel	µg/L	960	480

Table A.8. Fresh Water Bacteria Limitations

Receiving Water Bacteria TMDL		Units	Geometric Mean	Single Sample
E. coli		MPN/100 mL	126	235

Frequency of Discharge:

Groundwater discharge is expected to last for about 3 months or the duration of the construction repair project.

Reuse of Groundwater Water Discharge:

The Discharger submitted a feasibility study to the Regional Board analyzing water conservation, reuse, and/or alternative disposal options for the discharge. Groundwater will be used for dust control purposes. It is not feasible to recycle the groundwater for other useful purposes at the site, including for lawn irrigation. Therefore, the rest of the treated groundwater will be discharged to Arroyo Simi in compliance with the requirements of the attached Order R4-2018-0125.

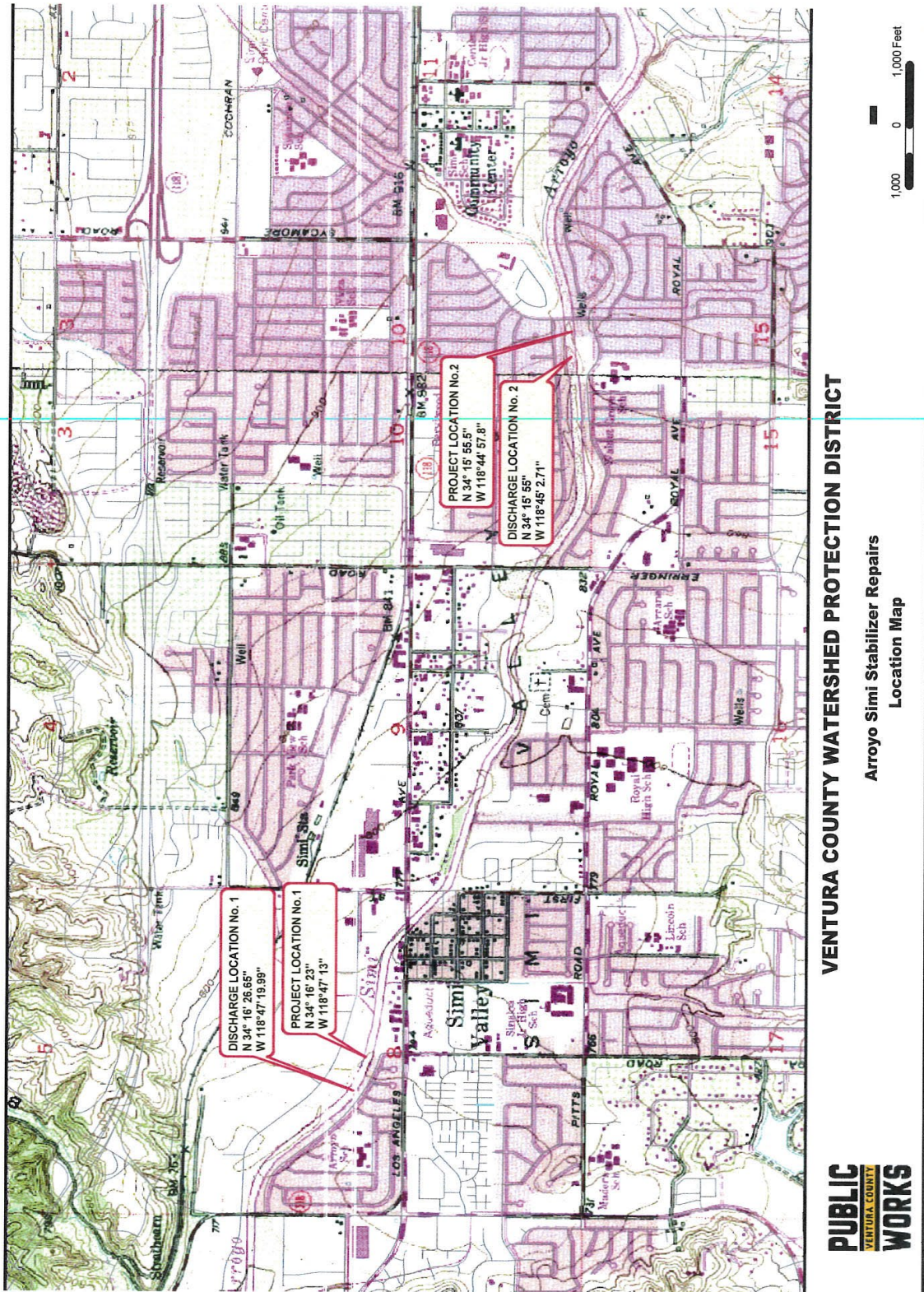

Figure 1. Location Map

VENTURA COUNTY WATERSHED PROTECTION DISTRICT

ARROYO SIMI REPAIRS

GROUNDWATER TREATMENT SCHEMATIC

IN SUPPORT OF THE GENERAL DISCHARGE PERMIT APPLICATION.

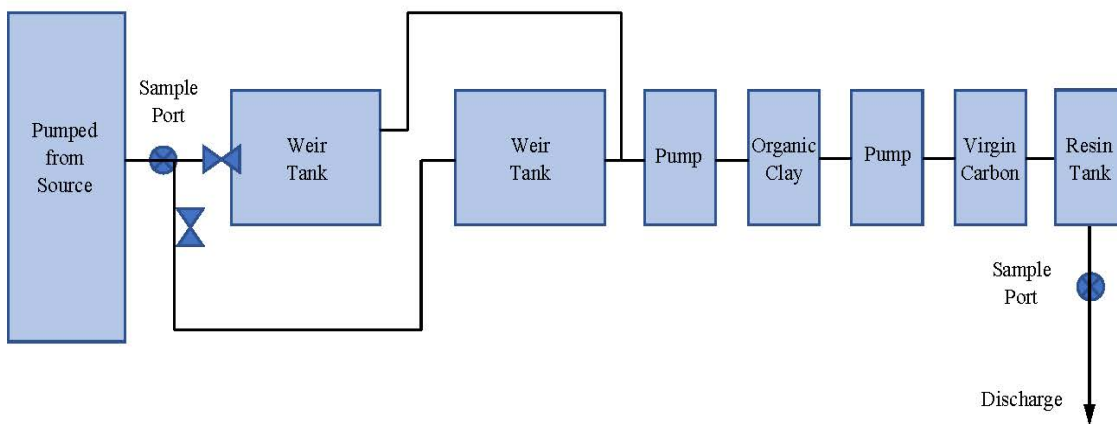

Figure 2—Treatment Schematic

STATE OF CALIFORNIA
CALIFORNIA REGIONAL WATER QUALITY CONTROL BOARD
LOS ANGELES REGION

Revised Monitoring and Reporting Program CI-10534
For

VENTURA COUNTY WATERSHED PROTECTION DISTRICT
(ARROYO SIMI SOUTH BANK UPSTREAM OF MODERA ROAD AND ARROYO SIMI
DOWNSTREAM OF SYCAMORE ROAD RESTORATION PROJECT)

For

Discharges of Groundwater from Construction and Project Dewatering to Surface
Waters in Coastal Watersheds of Los Angeles and Ventura Counties

(General NPDES Permit No. CAG994004, Order No. R4-2018-0125 Series No. 051)

This Order was adopted by the Regional Water Board on:	September 13, 2018
Enrollment to this Order shall become effective on:	April 17, 2020
This Order shall expire on:	November 13, 2023

The U.S. Environmental Protection Agency and the Regional Water Quality Control Board have classified discharges covered under this General Permit as a minor discharge.

Ordered by: _____

Renee Purdy
Executive Officer

Date: April 17, 2020

Table of Contents

Revised Monitoring and Reporting Program CI-10534	1
I. General Monitoring Provisions	3
II. Monitoring Locations	8
III. Influent Monitoring Requirements (Not Applicable).....	8
IV. Effluent Monitoring Requirements	8
V. Whole Effluent Toxicity Testing Requirements.....	10
A. Acute Toxicity Effluent Monitoring Program	10
B. Ammonia Removal	11
C. Chlorine Removal.....	12
D. Reporting.....	12
VI. Land Discharge Monitoring Requirements (Not Applicable)	13
VII. Reclamation Monitoring Requirements (Not Applicable).....	13
VIII. Receiving Water Monitoring Requirements – (Not Applicable).....	13
IX. Other monitoring requirements (Not Applicable).....	13
X. Reporting Requirements	13
A. General Monitoring and Reporting Requirements.....	13
B. Self-Monitoring Reports.....	13
C. Discharge Monitoring Reports (DMRs) (Not Applicable).....	16
D. Other Reports (Not Applicable)	16
E. Notification.....	16
XI. Monitoring Frequencies adjustment	17

Monitoring and Reporting Program (MRP)

40 CFR section 122.48 requires that all NPDES permits specify monitoring and reporting requirements. Sections 13267 and 13383 of the California Water Code (CWC) also authorize the Regional Water Board to require technical and monitoring reports. This MRP establishes monitoring and reporting requirements which implement the federal and California regulations.

I. General Monitoring Provisions

- A.** An effluent sampling station shall be established for Discharge Point M-001 and M-002 and, shall be located where representative samples of that effluent can be obtained.
- B.** This Regional Water Board shall be notified in writing of any change in the sampling stations once established or in the methods for determining the quantities of pollutants in the individual waste streams.
- C.** Pollutants shall be analyzed using the analytical methods described in 40 CFR section Sections 136.3, 136.4, and 136.5 (revised May 18, 2012); or, where no methods are specified for a given pollutant, by methods approved by this Regional Water Board or the State Water Board. U.S. EPA published regulations for the Sufficiently Sensitive Methods Rule (SSM Rule) which became effective September 18, 2015. For the purposes of the NPDES program, when more than one test procedure is approved under 40 C.F.R. part 136 for the analysis of a pollutant or pollutant parameter, the test procedure must be sufficiently sensitive as defined at 40 C.F.R. 122.21(e)(3) and 122.44(i)(1)(iv). Both 40 C.F.R sections 122.21(e)(3) and 122.44(i)(1)(iv) apply to the selection of a sufficiently sensitive analytical method for the purposes of monitoring and reporting under NPDES permits, including review of permit applications. A U.S. EPA-approved analytical method is sufficiently sensitive where:
 - 1. The State Water Resources Control Board Minimum Level (ML) is at or below both the level of the applicable water quality criterion/objective and the permit limitation for the measured pollutant or pollutant parameter; or
 - 2. In permit applications, the ML is above the applicable water quality criterion/objective, but the amount of the pollutant or pollutant parameter in a facility's discharge is high enough that the method detects and quantifies the level of the pollutant or pollutant parameter in the discharge; or
 - 3. The method has the lowest ML of the U.S. EPA-approved analytical methods where none of the U.S. EPA-approved analytical methods for a pollutant can achieve the MLs necessary to assess the need for effluent limitations or to monitor compliance with a permit limitation.

The MLs in Appendix 4 of the *Policy for the Implementation of Toxics Standards for Inland Surface Waters, Enclosed Bays, and Estuaries of California*, February 2005, (the Policy), which adopted amendments to the State Implementation Policy, March 2000 (SIP)) remain applicable. However, there may be situations when analytical methods are published with MLs that are more sensitive than the MLs for analytical methods listed in the Policy. For instance, U.S. EPA Method 1631E for mercury is not currently listed in Appendix 4 of the Policy and Appendix A of this permit order, but it is published with an method quantitation limit (also called reporting limit or minimum level) of 0.2 ng/L that makes it a sufficiently sensitive analytical method. Similarly, U.S. EPA Method 245.7 for mercury is published with an method quantitation limit of 5 ng/L.

- D. For any analyses performed for which no procedure is specified in the U.S. EPA guidelines or in the MRP, the constituent or parameter analyzed and the method or procedure used must be specified in the monitoring report.
- E. Laboratories analyzing effluent samples and receiving water samples shall be certified by the State Water Board Environmental Laboratory Approval Program (ELAP) or approved by the Regional Water Board Executive Officer (Executive Officer) and must include quality assurance/quality control (QA/QC) data in their reports. A copy of the laboratory certification shall be provided each time a new certification and/or renewal of the certification is obtained from ELAP.
- F. Each monitoring report must affirm in writing that “all analyses were conducted at a laboratory certified for such analyses by the State Water Board or approved by the Executive Officer and in accordance with current U.S. EPA guideline procedures or as specified in this Monitoring and Reporting Program”.
- G. The monitoring reports shall specify the analytical method, the Method Detection Limit (MDL), and the ML for each pollutant. For the purpose of reporting compliance with numerical limitations, performance goals, and receiving water limitations, analytical data shall be reported by one of the following methods, as appropriate:
 - 1. An actual numerical value for sample results greater than or equal to the ML; or
 - 2. “Detected, but Not Quantified (DNQ)” if results are greater than or equal to the laboratory’s MDL but less than the ML; or
 - 3. “Not Detected (ND)” for sample results less than the laboratory’s MDL with the MDL indicated for the analytical method used.

Analytical data reported as “less than” for the purpose of reporting compliance with permit limitations shall be the same or lower than the permit limit(s) established for the given parameter.

Current MLs, which are listed in Appendix A, are those published by the State Water Resources Control Board in the Policy.

- H.** Where possible, the MLs employed for effluent analyses shall be lower than the permit limitations established for a given parameter. If the ML value is not below the effluent limitation, then the lowest ML value and its associated analytical method shall be selected for compliance purposes. At least once a year, the Discharger shall submit a list of the analytical methods employed for each test and associated laboratory QA/QC procedures.

Where possible, the ML’s employed for effluent analyses not associated with determining compliance with effluent limitations in this order shall be lower than the lowest applicable water quality objective, for a given parameter. Water quality objectives for parameters may be found in the Basin Plan Chapter 3 and California Toxics Rule (40 CFR 131.38). If the ML value is not below the water quality objective, then the lowest ML value and its associated analytical method shall be selected for compliance purposes. At least once a year, the Discharger shall submit a list of the analytical methods employed for each test, the associated laboratory QA/QC procedures, reporting levels (RL’s), and MDL.

The Regional Water Board, in consultation with the State Water Board Quality Assurance Program, shall establish a ML that is not contained in Appendix A to be included in the Discharger’s permit in any of the following situations:

1. When the pollutant under consideration is not included in Appendix A;
2. When the Discharger and Regional Water Board agree to include in the permit a test method that is more sensitive than that specified in 40 CFR Part 136 (revised May 18, 2012);
3. When the Discharger agrees to use an ML that is lower than that listed in Appendix A;
4. When the Discharger demonstrates that the calibration standard matrix is sufficiently different from that used to establish the ML in Appendix A, and proposes an appropriate ML for their matrix; or,
5. When the Discharger uses a method whose quantification practices are not consistent with the definition of an ML. Examples of such methods are the USEPA-approved method 1613 for dioxins and furans, method 1624 for volatile organic substances, and method 1625 for semi-volatile organic

substances. In such cases, the Discharger, the Regional Water Board, and the State Water Board shall agree on a lowest quantifiable limit and that limit will substitute for the ML for reporting and compliance determination purposes.

- I. Water/wastewater samples must be analyzed within allowable holding time limits as specified in 40 CFR section 136.3. All QA/QC items must be run on the same dates the samples were actually analyzed, and the results shall be reported in the Regional Water Board format, when it becomes available, and submitted with the laboratory reports. Proper chain of custody procedures must be followed, and a copy of the chain of custody shall be submitted with the report.
- J. All analyses shall be accompanied by the chain of custody, including but not limited to date and time of sampling, sample identification, and name of person who performed sampling, date of analysis, name of person who performed analysis, QA/QC data, method detection limits, analytical methods, copy of laboratory certification, and a perjury statement executed by the person responsible for the laboratory.
- K. The Discharger shall calibrate and perform maintenance procedures on all monitoring instruments to insure accuracy of measurements, or shall insure that both equipment activities will be conducted.
- L. The Discharger shall have, and implement, an acceptable written quality assurance (QA) plan for laboratory analyses. The annual monitoring report required in Section X.b.3. of this MRP shall also summarize the QA activities for the previous year. Duplicate chemical analyses must be conducted on a minimum of ten percent (10%) of the samples, or at least one sample per sampling period, whichever is greater. A similar frequency shall be maintained for analyzing spiked samples.
- M. When requested by the Regional Water Board or U.S. EPA, the Discharger will participate in the NPDES discharge monitoring report QA performance study. The Discharger must have a success rate equal to or greater than 80%.
- N. For parameters that both monthly average and daily maximum limitations are specified and the monitoring frequency is less than four times a month, the following shall apply. If an analytical result is greater than the monthly average limitation, the Discharger shall collect four additional samples at approximately equal intervals until compliance with the monthly average limitation has been demonstrated. All five analytical results shall be reported in the monitoring report for that month, or 45 days after results for the additional samples were received, whichever is later. In the event of noncompliance with a monthly average effluent limitation, the sampling frequency for that constituent shall be increased to weekly and shall continue at this level until compliance with the

monthly average effluent limitation has been demonstrated. The Discharger shall provide for the approval of the Executive Officer a program to ensure future compliance with the monthly average limitation.

- O.** In the event wastes are transported to a different disposal site during the report period, the following shall be reported in the monitoring report:
1. Types of wastes and quantity of each type;
 2. Name and address for each hauler of wastes (or method of transport if other than by hauling); and
 3. Location of the final point(s) of disposal for each type of waste.

If no wastes are transported off-site during the reporting period, a statement to that effect shall be submitted.

- P.** Each monitoring report shall state whether or not there was any change in the discharge as described in the Order during the reporting period.
- Q.** All monitoring reports shall include the discharge limitations in the Order, tabulated analytical data, the chain of custody form, and the laboratory report (including but not limited to date and time of sampling, date of analyses, method of analysis and detection limits).
- R.** Each monitoring report shall contain a separate section titled "Summary of Non-compliance" which discusses the compliance record and corrective action taken or planned that may be needed to bring the discharge into full compliance with waste discharge requirements. This section shall clearly list all non-compliance with waste discharge requirements, as well as all excursions of effluent limitations.
- S.** Before commencing a new discharge, a representative sample of the effluent shall be collected and analyzed for toxicity and for all the constituents listed in Fact Sheet, and the test results must meet all applicable limitations of Order No. R4-2018-0125.
- T.** In the event of presence of oil sheen, debris, and/or other objectionable materials or odors, discharge shall not commence until compliance with the requirements is demonstrated. All visual observations shall be included in the monitoring report.
- U.** If monitoring results indicate an exceedance of a limit contained in Order R4-2018-0125, the discharge shall be terminated and shall only be resumed after remedial measures have been implemented and full compliance with the requirements has been ascertained.

V. In addition, as applicable, following an effluent limit exceedance, the Discharger shall implement the following accelerated monitoring program:

1. Monthly monitoring shall be increased to weekly monitoring
2. Quarterly monitoring shall be increased to monthly monitoring
3. Semi-annually monitoring shall be increased to quarterly
4. Annual monitoring shall be increased to semi-annually

If three consecutive accelerated monitoring events demonstrate full compliance with effluent limits, the Discharger may return to the regular monitoring frequency, with the approval of the Executive Officer of the Regional Water Board.

II. Monitoring Locations

The Discharger shall establish the following monitoring locations to demonstrate compliance with the effluent limitations, discharge specifications, and other requirements in this Order:

Table 1. Monitoring Points Information

Discharge Point Name	Monitoring Location Name	Monitoring Location Description
Discharge Point 1 (Arroyo Simi South Bank District's Access Road)	M-001	Treated effluent, after treatment and before contact with the receiving water and/or dilution by any other water or waste.
Discharge Point 2 (Arroyo Simi Downstream of Sycamore Road)	M-002	If more than one discharge point is authorized under the General Permit, compliance monitoring locations shall be named M-002, M-003, etc. and shall be located so as to allow collection of treated effluent after treatment and before contact with receiving water and/or dilution by any other water or waste.

III. Influent Monitoring Requirements (Not Applicable)

IV. Effluent Monitoring Requirements

The Discharger shall monitor the effluent at Discharge Point M-001 and M-002. (The representative effluent samples shall be collected after all treatment processes (if any) while discharging and before contact or mixing with receiving water or other waters and/or dilution with any other water or waste).

Table 2. Monitoring Constituents

Parameter	Units	Sample Type	Minimum Sampling Frequency	Required Analytical Test Method
Flow	gal/day	totalizer	continuously ³	4
pH	pH units	grab	monthly	4
Temperature	°F	grab	monthly	4
Total Suspended Solids	mg/L	grab	monthly	4
Turbidity	NTU	grab	monthly	4
BOD ₅ 20°C	mg/L	grab	monthly	4
Oil and Grease	mg/L	grab	monthly	4
Settleable Solids	ml/L	grab	monthly	4
Sulfides	mg/L	grab	monthly	4
Phenols	mg/L	grab	monthly	4
Residual Chlorine	mg/L	grab	monthly	4
Methylene Blue Active Substances	mg/L	grab	monthly	4
Nitrogen (Nitrate-nitrogen + Nitrite-nitrogen)	mg/L	grab	monthly	4
Selenium TR	µg/L	grab	weekly ⁵	4
Copper TR	µg/L	grab	weekly ⁵	4
Benzo (a) Pyrene	µg/L	grab	weekly ⁵	4
Benzo (b) Fluoranthene	µg/L	grab	weekly ⁵	4
Chrysene	µg/L	grab	weekly ⁵	4
Perchlorate	µg/L	grab	weekly ⁵	4
2,3,7,8-TCDD (Dioxin)	µg/L	grab	weekly ⁵	4
Total Petroleum Hydrocarbons (TPH)	µg/L	grab	weekly ⁵	4
Chlorpyrifos	µg/L	grab	quarterly	4
Diazinon	µg/L	grab	quarterly	4

³ Record the monthly total flow and report the calculated daily average flow and monthly flow in the quarterly and annual reports, as appropriate

⁴ Pollutants shall be analyzed using the analytical methods described in 40 CFR Part 136; for priority pollutants the methods must meet the lowest minimum levels (MLs) specified in Attachment 4 of the SIP (and included as Appendix A of this Order), where no methods are specified for a given pollutant, by methods approved by this Regional Water Board or the State Water Board.

⁵ Weekly for the first month and monthly thereafter if no exceedances for effluent limitations were observed.

Parameter	Units	Sample Type	Minimum Sampling Frequency	Required Analytical Test Method
Chlordane	ng/L	grab	quarterly	4
4,4-DDD	ng/L	grab	quarterly	4
4,4-DDE	ng/L	grab	quarterly	4
4,4-DDT	ng/L	grab	quarterly	4
Dieldrin	ng/L	grab	quarterly	4
PCBs	ng/L	grab	quarterly	4
Toxaphene	ng/L	grab	quarterly	4
Mercury	µg/L	grab	quarterly	4
Nickel	µg/L	grab	quarterly	4
E. coli	MPN/100 mL	grab	quarterly	4
Acute Toxicity	% survival	grab	annually	4

V. Whole Effluent Toxicity Testing Requirements

The MRP requires an annual test of Acute Toxicity, which measures primarily lethal effects that occur over a 96-hour period. Acute toxicity shall be recorded in percent survival measured in undiluted (100%) effluent.

A. Acute Toxicity Effluent Monitoring Program

1. The Discharger shall conduct acute toxicity tests on effluent samples (e.g., grab samples) by methods specified in 40 CFR Part 136 which cites U.S. EPA's *Methods for Measuring the Acute Toxicity of Effluents and Receiving Waters to Freshwater and Marine Organisms*, Fifth Edition, October 2002, U.S. EPA, Office of Water, Washington D.C. (EPA/821-R-02-012) or a more recent edition to ensure compliance in 100 % effluent.
2. The fathead minnow, *Pimephales promelas*, shall be used as the test species for discharge into freshwater and the topsmelt, *Atherinops affinis*, shall be used as the test species for discharge into coastal water. If the salinity of the receiving water is between 1 to 32 parts per thousand (ppt), the Discharger have the option of using the inland silverside, *Menidia beryllina*, instead of the topsmelt. The method for topsmelt (Larval Survival and Growth Test Method 1006.0) is found in U.S. EPA's Short-term Methods for Estimating the Chronic Toxicity of Effluent and Receiving Waters to West Coast Marine and Estuarine Organisms, First Edition, August 1995 (EPA/600/R-95/136), or a more recent edition. The method for *Pimephales promelas* is found in U.S. EPA's Acute Toxicity Test Method 2000.0 and method for *Menidia beryllina* is found in U.S. EPA's Acute Toxicity Test Method 2006.0, or a more recent edition.

3. In lieu of conducting the standard acute toxicity testing with the fathead minnow, the Discharger may elect to report the results or endpoint from the first 48 hours of the chronic toxicity test as the results of the acute toxicity test.
4. Accelerated Toxicity Monitoring: If the results of the toxicity test yield a survival of less than 90%, then the frequency of analyses shall increase to monthly until at least three test results have been obtained and full compliance with effluent limitations has been demonstrated, after which the frequency of analyses shall revert to annually. Results of toxicity tests shall be included in the first monitoring report following sampling.
5. Effluent samples shall be collected after all treatment processes and before discharge to the receiving water.

B. Ammonia Removal

1. Except with prior approval from the Executive Officer of the Regional Water Board, ammonia shall not be removed from bioassay samples. The Discharger must demonstrate the effluent toxicity is caused by ammonia because of increasing test pH when conducting the toxicity test. It is important to distinguish the potential toxic effects of ammonia from other pH sensitive chemicals, such as certain heavy metals, sulfide, and cyanide. The following may be steps to demonstrate that the toxicity is caused by ammonia and no other toxicants before the Executive Officer would allow for control of pH in the test.
 - a. There is consistent toxicity in the effluent and the maximum pH in the toxicity test is in the range to cause toxicity due to increased pH.
 - b. Chronic ammonia concentrations in the effluent are greater than 4 mg/L total ammonia.
 - c. Conduct graduated pH tests as specified in the toxicity identification evaluation methods. For example, mortality should be higher at pH 8 and lower at pH 6.
 - d. Treat the effluent with a zeolite column to remove ammonia. Mortality in the zeolite treated effluent should be lower than the non-zeolite treated effluent. Then add ammonia back to the zeolite-treated samples to confirm toxicity due to ammonia.
2. When it has been demonstrated that toxicity is due to ammonia because of increasing test pH, pH may be controlled using appropriate procedures which do not significantly alter the nature of the effluent, after submitting a written request to the Regional Water Board, and receiving written permission expressing approval from the Executive Officer of the Regional Water Board.

C. Chlorine Removal

Except with prior approval from the Executive Officer of the Regional Water Board, chlorine shall not be removed from bioassay sample.

D. Reporting

1. The Discharger shall submit a full report of the toxicity test results, including any accelerated testing conducted during the month as required by this General Permit. Test results shall be reported as % survival for acute toxicity test results with the self-monitoring reports (SMR) for the month in which the test is conducted.
2. If an initial investigation indicates the source of toxicity and accelerated testing is unnecessary, then those results also shall be submitted with the SMR for the period in which the investigation occurred.
 - a. The full report shall be submitted on or before the end of the month in which the SMR is submitted.
 - b. The full report shall consist of (1) the results; (2) the dates of sample collection and initiation of each toxicity test; (3) the acute toxicity average limit.
3. Test results for toxicity tests shall be reported according to the appropriate manual chapter on Report Preparation and shall be attached to the SMR. Routine reporting shall include, at a minimum, as applicable, for each test:
 - a) Sample date(s);
 - b) Test initiation date;
 - c) Test species;
 - d) End point values for each dilution (e.g., number of young, growth rate, percent survival);
 - e) Any applicable charts; and
 - f) Available water quality measurements for each test (e.g., pH, D.O., temperature, conductivity, hardness, salinity, ammonia).
4. The Discharger shall provide a compliance summary, which includes a summary table of toxicity data from all samples collected during that year.

The Discharger shall notify this Regional Water Board by calling Namiraj Jain (213) 620-6003 and by email to namiraj.jain@waterboards.ca.gov of any toxicity exceedance of the limit or trigger within 24 hours of receipt of the results followed by a written report within 14 calendar days of receipt of the results. The verbal or electronic notification shall include the exceedance and the plan

the Discharger has taken or will take to investigate and correct the cause(s) of toxicity. It may also include a status report on any actions required by the permit, with a schedule for actions not yet completed. If no actions have been taken, the reasons shall be given.

VI. Land Discharge Monitoring Requirements (Not Applicable)

VII. Reclamation Monitoring Requirements (Not Applicable)

VIII. Receiving Water Monitoring Requirements – (Not Applicable)

IX. Other monitoring requirements (Not Applicable)

X. Reporting Requirements

A. General Monitoring and Reporting Requirements

The Discharger shall comply with all Standard Provisions (Attachment D) related to monitoring, reporting, and recordkeeping.

1. If there is no discharge during any reporting period, the report shall so state.
2. Each monitoring report shall contain a separate section titled "Summary of Non-Compliance" which discusses the compliance record and corrective actions taken or planned that may be needed to bring the discharge into full compliance with waste discharge requirements. This section shall clearly list all non-compliance with waste discharge requirements, as well as all excursions of effluent limitations.
3. The Discharger shall inform the Regional Water Board well in advance of any proposed construction activity that could potentially affect compliance with applicable requirements.

B. Self-Monitoring Reports

1. At any time during the term of this General Permit, the State or Regional Water Board may notify the Discharger to electronically submit Self-Monitoring Reports (SMRs) using the State Water Board's California Integrated Water Quality System (CIWQS) Program Web site (<http://www.waterboards.ca.gov/ciwqs/index.html>). Until such notification is given, the Discharger shall email electronic copy of SMRs to losangeles@waterboards.ca.gov. The CIWQS Web site will provide additional directions for SMR submittal in the event there will be service interruption for electronic submittal.

2. The Discharger shall report in the SMR the results for all monitoring specified in this MRP. The Discharger shall submit SMRs including the results of all required monitoring using U.S. EPA-approved test methods or other test methods specified in this Order. If the Discharger monitors any pollutant more frequently than required by this Order, the results of this monitoring shall be included in the calculations and reporting of the data submitted in the SMR.

3. Monitoring periods and reporting for all required monitoring shall be completed according to the following schedule: Monitoring Periods and Reporting Schedule.

Table 3. Monitoring Periods and Reporting Schedule

Sampling Frequency	Monitoring Period Begins On	Monitoring Period	SMR Due Date
Continuously	April 17, 2020	Continuously	Submit with quarterly SMR
Monthly	First day of calendar month following permit effective date or on permit effective date, if that date is first day of the month.	1 st day of calendar month through last day of calendar month.	Submit with quarterly SMR
Quarterly	Closest of January 1, April 1, July 1, or October 1	Jan 1 through Mar. 31; Apr 1 through June 30; July 1 through 30; Oct. 1 through Dec. 31	45 days from the end of the monitoring period
Annually	January 1 following (or on) April 17, 2020	January 1 through December 31	45 days from the end of the monitoring period

4. Reporting Protocols. The Discharger shall report with each sample result the applicable Reporting Level (RL) and the current Method Detection Limit (MDL), as determined by the procedure in Part 136.

The Discharger shall report the results of analytical determinations for the presence of chemical constituents in a sample using the following reporting protocols:

- a. Sample results greater than or equal to the RL shall be reported as measured by the laboratory (i.e., the measured chemical concentration in the sample).

- b. Sample results less than the RL, but greater than or equal to the

laboratory's MDL, shall be reported as "Detected, but Not Quantified," or DNQ. The estimated chemical concentration of the sample shall also be reported.

For the purposes of data collection, the laboratory shall write the estimated chemical concentration next to DNQ as well as the words "Estimated Concentration" (may be shortened to "Est. Conc."). The laboratory may, if such information is available, include numerical estimates of the data quality for the reported result. Numerical estimates of data quality may be percent accuracy (\pm a percentage of the reported value), numerical ranges (low to high), or any other means considered appropriate by the laboratory.

- c. Sample results less than the laboratory's MDL shall be reported as "Not Detected," or ND.
 - d. Dischargers are to instruct laboratories to establish calibration standards so that the ML value (or its equivalent if there is differential treatment of samples relative to calibration standards) is the lowest calibration standard. At no time is the Discharger to use analytical data derived from *extrapolation* beyond the lowest point of the calibration curve.
5. The Discharger shall submit SMRs in accordance with the following requirements:
- a. Data Summary Tables: The Discharger shall arrange all reported data in a tabular format. The data shall be summarized to clearly illustrate whether the facility is operating in compliance with interim and/or final effluent limitations. The Discharger is not required to duplicate the submittal of data that is entered in a tabular format within CIWQS. When electronic submittal of data is required and CIWQS does not provide for entry into a tabular format within the system, the Discharger shall electronically submit the data in a tabular format as an attachment.
 - b. Cover letter and Summary of Non-Compliance: The Discharger shall attach a cover letter to the SMR. The information contained in the cover letter shall clearly identify violations of the WDRs; discuss corrective actions taken or planned; and the proposed time schedule for corrective actions. Identified violations must include a description of the requirement that was violated and a description of the violation.
 - c. Paperless Submittal of SMRs: SMRs must be submitted to the Regional Water Board, signed and certified as required by the Standard Provisions (Attachment D). The Regional Water Board is implementing a paperless office system to reduce paper use, increase efficiency and provide a more effective way for our staff, the public and interested parties to view water quality documents. Therefore, please convert all regulatory documents, submissions, data and correspondence that you would normally submit to

us as hard copies to a searchable Portable Document Format (PDF). Documents that are less than 10 MB should be emailed to losangeles@waterboards.ca.gov. Documents that are 10 MB or larger should be transferred to a disk and mailed to the address listed below.

CRWQCB – Los Angeles Region
320 West 4th Street, Suite 200
Los Angeles, CA 90013
Attn: Information & Technology Unit

If you need additional information regarding electronic submittal of documents please visit and navigate the Paperless Office pages in the Regional Water Board's website at <http://www.waterboards.ca.gov/losangeles/resources/Paperless/>.

C. Discharge Monitoring Reports (DMRs) (Not Applicable)

D. Other Reports (Not Applicable)

E. Notification

- A. The Discharger shall notify the Executive Officer in writing prior to discharge of any chemical which may be toxic to aquatic life. Such notification shall include:
1. Name and general composition of the chemical
 2. Frequency of use
 3. Quantities to be used
 4. Proposed discharge concentrations and
 5. U.S. EPA registration number, if applicable

No discharge of such chemical shall be made prior to obtaining the Executive Officer's approval.

- B. The Discharger shall notify the Regional Board by calling Namiraj Jain at (213) 620-6003 and/or email to namiraj.jain@waterboards.ca.gov within 24 hours of noticing an exceedance above the effluent limits in Order No. R4-2018-0125. The Discharger shall provide to the Regional Water Board within 14 days of observing the exceedance a detailed statement of the actions undertaken or proposed that will bring the discharge into full compliance with the requirements and submit a timetable for correction.

C. Pre-Discharge Notification

Three (3) days prior to initiation of a discharge, the Discharger shall notify the MS4 operator Ventura County Flood Control District at

Discharge.alert@ventura.org and provide the following information about the discharge:

1. The reasons for discharge
2. The start date of discharge
3. The location of discharge and the applicable receiving water
4. The estimated flow rate discharge, indicating if the discharge is intermittent or continuous

XI. Monitoring Frequencies adjustment

Monitoring frequencies may be adjusted by the Executive Officer to a less frequent basis if the Discharger makes a request and the request is backed by statistical trends of monitoring data submitted.