

**CALIFORNIA REGIONAL WATER QUALITY CONTROL BOARD
LOS ANGELES REGION**

320 West 4th Street, Suite 200, Los Angeles, California, 90013
(213) 576-6600 • Fax (213) 576-6660
<http://www.waterboards.ca.gov/losangeles>

**ORDER NO. R4-2021-0044
(FILE NO. 20-090)
WASTE DISCHARGE REQUIREMENTS
AND
WATER RECLAMATION REQUIREMENTS
CITY OF SANTA MONICA
SUSTAINABLE WATER INFRASTRUCTURE PROJECT (SWIP)**

The following Permittee is subject to Waste Discharge Requirements (WDRs) and Water Reclamation Requirements (WRRs) set forth in this Order:

TABLE 1. PERMITTEE INFORMATION

Permittee	City of Santa Monica (City or Permittee)
Name of Facility	SWIP Advanced Water Treatment Facility (AWTF or Facility)
Facility Address	1771 Main Street Santa Monica, CA 90401

TABLE 2. ADMINISTRATIVE INFORMATION

This Order was adopted and shall become effective on:	February 11, 2021
---	-------------------

I, Renee Purdy, Executive Officer, do hereby certify that this Order with all attachments is a full, true, and correct copy of the Order adopted by the California Regional Water Quality Control Board, Los Angeles Region (Los Angeles Water Board), on the date indicated above.

Renee Purdy, Executive Officer

CONTENTS

1. BACKGROUND INFORMATION..... 3
2. RECYCLED WATER DISTRIBUTION SYSTEM 6
3. ADVANCED-TREATED RECYCLED WATER QUALITY 7
4. SMURRF TREATED WATER QUALITY 7
5. GROUNDWATER BASIN 8
6. PURPOSE OF ORDER 8
7. REGULATION OF RECYCLED WATER..... 9
8. OTHER APPLICABLE PLANS, POLICIES AND AUTHORITIES 12
1. INFLUENT SPECIFICATIONS 20
2. RECYCLED WATER TREATMENT SPECIFICATIONS 21
3. RECYCLED WATER DISCHARGE LIMITATIONS 21
4. RATIONALE FOR DISCHARGE LIMITATIONS 22
5. GENERAL REQUIREMENTS 23
6. SPECIFICATIONS FOR USE OF RECYCLED WATER 25
7. USE AREA REQUIREMENTS 25
8. SPECIFICATIONS AND REQUIREMENTS FOR DUAL-PLUMBED SYSTEMS... 28
9. DDW SPECIFICATIONS AND REQUIREMENTS..... 30
10. ADDITIONAL PROVISIONS..... 31
11. REOPENER 33
12. ENFORCEMENT 34

TABLES

TABLE 1. PERMITTEE INFORMATION 1
TABLE 2. ADMINISTRATIVE INFORMATION..... 1
TABLE 3. TERTIARY-TREATED RECYCLED WATER USERS..... 6
TABLE 4. BENEFICIAL USES OF GROUNDWATER..... 12
TABLE 5. GROUNDWATER QUALITY OBJECTIVES FOR SALTS..... 12
TABLE 6. DISCHARGE LIMITATIONS NONPOTABLE USES 21

ATTACHMENTS

ATTACHMENT A – DEFINITIONS..... A-1
ATTACHMENT B – SWIP PROJECT FLOW DIAGRAM..... B-1
ATTACHMENT C1 – AWTF PROCESS FLOWDIAGRAM C-1
ATTACHMENT C2 – RECYCLED WATER DISTRIBUTION AREA..... C-2
ATTACHMENT C3 – SANTA MONICA GROUNDWATER SUBBASINS C-3
ATTACHMENT D - STANDARD PROVISIONS D-1
ATTACHMENT E – MONITORING AND REPORTING PROGRAM (MRP) CI-10569... E-1
ATTACHMENT F – DDW CONDITIONAL ACCEPTANCE LETTER..... F-1

The California Regional Water Quality Control Board, Los Angeles Region (Los Angeles Water Board) finds the following:

1. BACKGROUND INFORMATION

1.1. Permittee

The City of Santa Monica (City or Permittee) is a beachside city of 8.3 square miles on the west side of Los Angeles County. The City has a population of approximately 93,000 and produces municipal and commercial wastewater that is mostly conveyed to the Hyperion Water Reclamation Plant, owned and operated by the City of Los Angeles, Bureau of Sanitation.

1.2. Sustainable Water Infrastructure Project (SWIP)

Overview

The City of Santa Monica is developing a recycled water program to achieve long-term water self-sufficiency. When fully implemented, the Sustainable Water Infrastructure Project (SWIP) will allow the City to reuse up to 1.5 million gallons per day (mgd) of stormwater, brackish water, dry-weather runoff, and treated wastewater within the city. A conceptual flow diagram of the SWIP is included in Attachment B and the project consists of the following:

1.2.1. Advanced Water Treatment Facility (AWTF)

Construction and operation of an AWTF that will collect up to 1.5 mgd raw wastewater, stormwater, and dry-weather runoff from the city and produce up to 1.2 mgd advanced treated recycled water for nonpotable and indirect potable reuse. The AWTF advanced treated recycled water will be mixed with treated water from the Santa Monica Urban Runoff Recycling Facility (SMURRF) before being used for nonpotable reuse and, subject to future permitting, indirect potable reuse.

1.2.2. Civic Center Stormwater Harvesting Tank

Construction and operation of a 1.5 million gallon below-grade stormwater harvesting tank under the City's Civic Center parking lot to convey stormwater and dry-weather runoff from the City's Municipal Separate Storm Sewer System and Civic Center parking lot to the AWTF.

1.2.3. SMURRF Upgrades

Installation of a Reverse Osmosis unit at the SMURRF and enclosing the UV system and final effluent basin. The SMURRF currently acts as a Best Management Practice (BMP) for stormwater management and treats both stormwater and dry weather runoff for nonpotable reuse. Since there is often insufficient stormwater and dry-weather runoff to run the SMURRF, the SMURRF influent is supplemented with potable water. To reduce the need for potable water, the City also plans to convey brackish water from the City's Clean Beaches Initiative tank to

the SMURRF. Section 4 includes additional information on the SMURRF processes.

1.2.4. Injection Wells

Installation of a groundwater injection and monitoring well network to operate the SWIP as a Groundwater Replenishment Reuse Project (GRRP). Advanced treated recycled water from the AWTF and upgraded SMURRF will be conveyed to the injection wells through an extension of the existing recycled water pipeline. A groundwater monitoring plan will also be developed to monitor the impacts the injected water has on the groundwater basin before the GRRP begins operation.

Elements Permitted by the Los Angeles Water Board:

This permit only regulates the activities in the SWIP involving nonpotable reuse. Specifically, the permit regulates the AWTF and the AWTF effluent water quality. The City will submit an updated Report of Waste Discharge (ROWD) to the Los Angeles Water Board once the GRRP is incorporated into the Engineering Report and approved by the State Water Resources Control Board, Division of Drinking Water (DDW). The Los Angeles Water Board will then consider amending this Order to permit operation of the GRRP.

1.3. Facility and Project Description

The AWTF will produce up to 1.2 mgd advanced treated recycled water from a mixture of raw wastewater from the City's sanitary sewer, stormwater, and dry-weather runoff, when available. The influent to the AWTF will be 100% raw wastewater when no other sources are available. When stormwater or dry-weather runoff is available, the typical influent will be up to 70% raw wastewater and 30% stormwater or dry-weather runoff. If the AWTF is shut down or if the water does not meet Title 22 specifications, the wastewater will be directed to the sewer for treatment at the City of Los Angeles' Hyperion Water Reclamation Plant. Treatment at the Santa Monica AWTF will consist of headworks fine screening, Membrane Bioreactor (MBR), cartridge filtration, Reverse Osmosis (RO), Ultraviolet-Advanced Oxidation Process (UVAOP), chlorine disinfection, and post treatment stabilization as presented below and in Attachment C1:

Headworks Fine Screen – To minimize the presence of inert solids such as grit, hair, and fibrous materials entering the MBR, a headworks system will screen the raw influent wastewater, stormwater, and dry-weather runoff. A single 2 mm perforated drum screen with a hydraulic capacity of 1.5 mgd will provide the required screening with no possibility of unscreened bypass to downstream processes.

MBR – After the headworks, screened influent will flow by gravity, mix with Return Activated Sludge (RAS), and enter the MBR. The MBR consists of two biological trains and two membrane trains. Each biological train will be divided into two compartments, one anoxic zone and one aerobic zone, to provide nitrification-denitrification of the wastewater along with oxidizing the

wastewater. One MBR feed pump per biological train will pump the water from the aeration tank to a common MBR feed tank that allows flow into either membrane tank. RAS will flow by gravity over an overflow weir into a common RAS channel, where it will mix with screened influent and be discharged to either biological train. This mixture of RAS with influent maintains a sufficient concentration of mixed liquor suspended solids (MLSS) in the MBR. Each train is sized to provide half the capacity of the AWTF while meeting the appropriate pathogen reduction credits. Waste Activated Sludge (WAS) will be discharged to the Sump Pump Station to maintain a desired MLSS concentration within the MBR. The Sump Pump Station will ultimately discharge WAS to the downstream sanitary sewer. An automatic Clean-in-Place (CIP) system will be installed for the membranes that consists of dosing acid and/or sodium hypochlorite into the membrane tanks to remove accumulated organic matter or crystalized salts.

Cartridge Filtration - Cartridge filtration is typically provided upstream of RO units to protect the membranes. The cartridge filters will be selected based on acceptance under the Surface Water Treatment Rule for pathogen reduction credits. The cartridge filters are made of pleated microfiber media that is NSF-61 certified for removal of cyst-sized particles. Monitoring of the cartridge filters will be performed to ensure they remain within the prescribed limits for flow rate, pressure differential, and discharge turbidity.

RO – Following cartridge filtration, flow will pass through the RO system, which removes dissolved inorganic and organic components in the MBR filtrate. To control scaling and to protect the RO membranes, pretreatment consisting of chemical dosing with a threshold inhibitor and sulfuric acid for pH control will be provided. A CIP system and a flushing water system for the RO membranes are essential to maintain the RO performance. RO concentrate is discharged to the Sump Pump Station for disposal to the Hyperion Water Reclamation Plant via the downstream sanitary sewer.

UVAOP – The UVAOP at the AWTF will consist of UV irradiation with chlorine added as an oxidant upstream of the UV trains for advanced oxidation. UVAOP is used to disinfect RO permeate and destroy constituents of emerging concern (CECs) that pass through the RO membranes due to their low molecular weight and low ionic charge, notably N-Nitrosodimethylamine (NDMA) and 1,4-dioxane. UVAOP effectively reduces and inactivates pathogenic microorganisms and achieves the maximum disinfection credits allowed for target microorganisms. The chlorine used for oxidation also provides the disinfectant residuals needed for further virus reduction in the downstream chlorine contact tank. The inactivation of microorganisms and reduction of micropollutants vary with the UV dose, which is a product of the UV light intensity and the exposure time, and the chlorine dose.

Chlorine Disinfection – Discharge from the UVAOP will flow to a chlorine contact tank for further virus reduction. Residual free chlorine concentration from the UVAOP will serve as the base for chlorine concentration, with an injection point upstream of the chlorine contact tank to add additional free chlorine if higher chlorine contact time (CT) values are needed. The chlorine contact tank provides 11.2 minutes of hydraulic retention time at peak flow. A tracer study will be performed to determine the baffling factor in CT calculations.

Post Treatment Stabilization - To stabilize the product water and protect the distribution system against corrosion, sodium carbonate is added to the flow to adjust the pH before it enters the distribution system and the pipelines to the injection wells.

2. RECYCLED WATER DISTRIBUTION SYSTEM

The City plans to distribute a mixture of advanced-treated recycled water, stormwater, dry-weather runoff, and SMURRF effluent for nonpotable uses such as landscape irrigation and toilet/urinal flushing in dual-plumbed systems. Table 3 below lists the recycled water users and Attachment C2 depicts the current recycled water distribution area.

TABLE 3. TERTIARY-TREATED RECYCLED WATER USERS

Recycled Water User	Facility Owner	Use Type	Address	Land Use
Tongva Park	City	Irrigation	1700 Main Street	Parks/ Open Space
Palisades Park	City	Irrigation	1250 Ocean Avenue	Parks/ Open Space
Memorial Park	City	Irrigation	1401 Olympic Boulevard	Parks/ Open Space
Municipal Cemetery	City	Irrigation	1823 15 th Street	Institutional/ Public Lands
Municipal Bus Yard	City	Irrigation	1620 6 th Street	Downtown Core
Parking Lot near Metro Station	City	Irrigation	1636 5 th Street	Institutional/ Public Lands
City Hall	City	Irrigation	1685 Main Street	Institutional/ Public Lands
Median at Olympic Boulevard	City	Irrigation	1401 – 2400 Olympic Boulevard	Public Right-of-Way
Parkway at Colorado and 11 th Street	City	Irrigation	1600 11 th Street	Public Right-of-Way
Landscape at Colorado Esplanade	City	Irrigation	224 Colorado Avenue	Public Right-of-Way
The Rand Corp	Private	Irrigation/ Dual Plumbed System	1776 Main Street	Institutional/ Public Lands
Step Up On Colorado L.P.	Private	Irrigation	520 Colorado Avenue	Downtown Core
The Waverly Owners Association	Private	Irrigation	1705 Ocean Avenue	Institutional/ Public Lands

Recycled Water User	Facility Owner	Use Type	Address	Land Use
Water Garden Company LLC	Private	Irrigation	1620 26 th Street	Office Campus
Public Safety Building	City	Dual-Plumbed System	333 Olympic Drive	Institutional/ Public Lands
Median at Olympic Boulevard	City	Irrigation	1000-2400 Olympic Boulevard Median	Public Right-of-Way
I-10 Freeway Landscaping	State/ Caltrans District 07	Irrigation	1702 Santa Monica Freeway	State Right-of-Way
Other/ Filling Station	City	Other/ Filling Station for Street Cleaning, Sewer Jetting	1000 Olympic Boulevard, 1300 Ocean Avenue, 1600 Delaware Avenue, 1600 Main Street, 300 Colorado Avenue	Public Right-of-Way

3. ADVANCED-TREATED RECYCLED WATER QUALITY

The advanced-treated recycled water produced at the AWTF will meet the requirements in Title 22 of the California Code of Regulations (22 CCR), Chapter 3, Article 5.2 for indirect potable reuse: Groundwater Replenishment – Subsurface Application. The advanced treated recycled water will be higher quality than is required for nonpotable reuse applications, including decorative fountains.

4. SMURRF TREATED WATER QUALITY

- 4.1. The City of Santa Monica owns and operates the SMURRF, which currently treats stormwater and dry-weather runoff for nonpotable reuse. The City has been operating the SMURRF since 2000 as a stormwater and dry-weather runoff Best Management Practice (BMP).
- 4.2. The treatment system at the SMURRF currently consists of screening, grit removal, dissolved air flotation, ultrafiltration, UV disinfection, and sodium hypochlorite disinfection.
- 4.3. In the future, the City intends to convey brackish groundwater from the Clean Beaches Initiative (CBI) project tank to the SMURRF, at which time the City will add reverse osmosis (RO) treatment to the SMURRF. This additional treatment is necessary to ensure the SMURRF water meets Title 22 diluent water requirements before it is mixed with the advanced-treated recycled water and injected into the groundwater basin.
- 4.4. Influent water quality to the SMURRF and CBI project tank was monitored for 341 different pollutants from November 18, 2018 to November 25, 2019. The SMURRF and the CBI tank influent exceeded the Maximum Contaminant Levels (MCLs), or Notification Levels (NLs) for several pollutants. However, the additional treatment by reverse osmosis will reduce those pollutant concentrations to below the MCLs and NLs. The water quality of the

SMURRF and CBI tank influent in wet and dry weather is similar; however, iron and manganese concentrations tend to be higher during wet weather in the SMURRF influent. PFOS and PFOA were also closely monitored to ensure the planned treatment process will be sufficient to keep the concentrations of these pollutants below their NLs. The City is continuing to monitor the SMURRF and CBI tank influent to determine its suitability as diluent water in the future.

- 4.5. The effluent from the SMURRF with RO will be required to meet all MCLs and NLs before use as a diluent water, and will be monitored once the advanced-treatment upgrades are complete.

5. GROUNDWATER BASIN

- 5.1. The Santa Monica Groundwater Basin (SMGB) is nonadjudicated and encompasses a surface area of approximately 50 square miles. The boundaries of the basin underlie the entire city limits and extend beyond the city boundaries into those of the City of Los Angeles to the north, east, and south. There are five separate subbasins within the SMGB, namely the Arcadia, Charnock, Coastal, Crestal, and Olympic subbasins. See Attachment C3 for a map depicting each of the subbasins. The subbasin boundaries loosely coincide with major geological structural features (e.g., faults) in the SMGB, but in some cases are defined using a combination of topography, sedimentation and/or geologic faulting. The sediments/rocks within and beneath the City of Santa Monica's portion of the SMGB are divided into two broad groups: (1) a potentially water-bearing sediments group (these deposits tend to be readily capable of absorbing, storing, transmitting and yielding groundwater to water wells) and (2) a non-water-bearing rocks group, which underlies the water-bearing sediments group and which is comprised by geologically old, lithified, or cemented sedimentary rocks and/or crystalline rocks of low permeability.
- 5.2. This Order does not currently permit any groundwater recharge operations that will take place in the future. The recycled water use areas, as well as the groundwater injection locations, are located above the SMGB in the Los Angeles Coastal Plain. The City must submit an amended Report of Waste Discharge and amended Antidegradation Study, as described in section 8.3.2 below, and these WDRs must be amended before such use is permissible.

6. PURPOSE OF ORDER

- 6.1. On April 22, 2020, the City submitted a Report of Waste Discharge to the Los Angeles Water Board to permit the use of AWTF advanced-treated recycled water for nonpotable uses. On May 01, 2020 the Los Angeles Water Board requested additional information to complete the application. The City provided additional information on June 08, 2020 and the Los Angeles Water Board deemed the ROWD complete on August 21, 2020.
- 6.2. The City submitted a Title 22 Engineering Report for the production, distribution, and use of advanced-treated recycled water from the City's new

AWTF on April 22, 2020 for which DDW provided comments on June 01, 2020. The City submitted a revised Title 22 Engineering Report dated July 16, 2020 and DDW conditionally approved the Title 22 Engineering Report on August 19, 2020.

- 6.3. This Order includes findings and requirements necessary to ensure the advanced-treated recycled water produced by the AWTF complies with the applicable policies. The City is responsible for producing recycled water that is at least equivalent to disinfected tertiary recycled water, processing individual end-user applications, inspecting point-of-use facilities, and ensuring end-users' compliance with the requirements contained in this Order. The actual delivery of recycled water to end-users is subject to approval by DDW and/or its delegated local health agency.

7. REGULATION OF RECYCLED WATER

- 7.1. State authority to oversee recycled water use is shared by the State Water Resources Control Board (State Water Board) including DDW, and the Los Angeles Water Board. DDW is the agency with the primary responsibility for establishing water recycling criteria under the California Code of Regulations (CCR) title 22 to protect the health of the public while using recycled water. The State Water Board and the regional water boards are responsible for issuing WDRs and WRRs for water that is used or proposed to be used as recycled water.
- 7.2. On January 6, 1977, the State Water Board adopted Resolution No. 77-1, Policy with Respect to Water Reclamation in California, which includes principles that encourage and recommend funding for water recycling and its use in water-short areas of the state. On September 26, 1988 the Los Angeles Water Board also adopted Resolution No. 88-012, which encourages the beneficial use of recycled wastewater and supports water recycling projects.
- 7.3. The State Water Board adopted the Water Quality Control Policy for Recycled Water (Recycled Water Policy, State Water Board Resolution No. 2009-0011) on February 3, 2009 and amended the Policy on January 22, 2013 (State Water Board Resolution No. 2013-0003). The Recycled Water Policy was further amended and adopted on December 11, 2018 (State Water Board Resolution No. 2018-0057) by the State Water Board and approved by the Office of Administrative Law (OAL) on April 08, 2019. In part, the purpose of the Recycled Water Policy is to increase the beneficial use of recycled water from municipal wastewater sources in a manner consistent with state and federal water quality laws and regulations and to protect groundwater resources. This Order includes requirements consistent with the Recycled Water Policy.
- 7.4. In section 4 of the amended Recycled Water Policy (Resolution No. 2018-0057), the State Water board and the regional water boards are the two

primary agencies with jurisdiction over the use and regulation of recycled water. The State Water Board:

- establishes general policies governing the permitting of recycled water projects,
- develops uniform water recycling criteria appropriate to particular uses of water and processes,
- approves wastewater change petitions filed by wastewater dischargers for recycled water projects that have the potential to decrease flow in any portion of a watercourse such as a river or stream,
- adopts statewide orders for the permitting of recycled water projects,
- reviews and approves Title 22 engineering reports for recycled water use, and
- allocates and disperses funding for recycled water projects consistent with its roles of protecting water quality, public health, and sustaining water supplies.

The State Water Board also exercises general oversight of recycled water projects, including review of regional water board permitting practices.

The regional water boards issue permits that include requirements needed to protect water quality, human health, and the environment consistent with the State and Regional Water Quality Control Plans, policies, and applicable law. The regional water boards also exercise their authority to encourage the use of recycled water.

- 7.5. CWC section 13523(a) provides that a regional water board, after consulting with and receiving recommendations from DDW or its delegated local health agency, and after any necessary hearing, shall, if it determines such action to be necessary to protect the health, safety, or welfare of the public, prescribe WRRs for water that is used or proposed to be used as recycled water. CWC section 13523 further provides that, at a minimum, the WRRs shall include, or be in conformance with, the statewide water recycling criteria established by DDW pursuant to CWC section 13521.
- 7.6. CWC section 13523.5, on WRRs, states that a regional water board may not deny issuance of WRRs to a project that violates only a salinity standard in a Basin Plan. This provision does not apply to WDRs. WDRs for projects that recycle water may contain effluent and other limitations on discharges of salts, as necessary to meet water quality objectives, comply with the Antidegradation Policy or otherwise protect beneficial uses.
- 7.7. Pursuant to CWC section 13523, the Los Angeles Water Board has consulted with DDW regarding the proposed recycling project and has incorporated their recommendations into this Order.
- 7.8. Section 7.4 of the Recycled Water Policy states that site-specific groundwater monitoring shall not be required for irrigation projects where recycled water is

applied at rates that minimize percolation of recycled water below the plants' root zone and account for the nutrient levels in the recycled water and nutrient demand by plants when applying fertilizers. The Recycled Water Policy also includes exceptions to this exemption from groundwater monitoring including when a regional water board determines there are unique site-specific conditions or such project-specific monitoring is required under the accepted salt and nutrient management plan, applicable basin plan, or other water board program such as the Irrigated Lands Program. Unique site-specific conditions include but are not limited to recycled water that is proposed to be used for irrigation over high transmissivity soils over a shallow (5 feet or less) high quality groundwater aquifer or proposed to be stored in unlined ponds where the regional water board determines that it will result in an unacceptable threat to groundwater quality. This Order is being issued without site-specific groundwater monitoring since the irrigation permitted under this Order requires the recycled water to be applied at rates that minimize percolation below the plants' root zone. The exceptions to the exemption do not apply because there are no site-specific conditions that may result in an unacceptable threat to groundwater quality when recycled water is used in compliance with this Order.

- 7.9. It is the intent of the recycled water policy for salts and nutrients to be addressed regionally rather than imposing requirements solely on individual recycled water projects. Section 6.1.2 of the Recycled Water Policy states, "Salts and nutrients from all sources must be managed on a basin-wide or watershed-wide basis in a manner that ensures attainment of water quality objectives and protection of beneficial uses. The most effective way to address salt and nutrient loading is typically through the development of regional or subregional salt and nutrient management plans rather than imposing requirements solely on individual recycled water projects or other individual sources of salts and nutrients."
- 7.10. A goal of the Recycled Water Policy is to increase the beneficial use of recycled water from municipal wastewater sources in a manner consistent with state and federal water quality laws and regulations. The Recycled Water Policy directs the regional water boards to collaborate with generators of municipal wastewater and interested parties in the development of SNMPs to manage loadings of salts and nutrients to groundwater basins in a manner that is protective of beneficial uses, thereby supporting the sustainable use of local waters. The City is currently developing a Salt and Nutrient Management Plan for the Santa Monica Groundwater Basin. Since there is no SNMP for the Santa Monica Groundwater Basin currently, the City has provided an Antidegradation Study for nonpotable reuse of the recycled water, as described in section 8.3.2 below.

8. OTHER APPLICABLE PLANS, POLICIES AND AUTHORITIES

8.1. THE BASIN PLAN

- 8.1.1. The Water Quality Control Plan for the Los Angeles Region: Basin Plan for the Coastal Watersheds of Los Angeles and Ventura Counties (Basin Plan) designates beneficial uses for surface and groundwater; establishes narrative and numeric water quality objectives that shall be attained or maintained to protect the designated (existing and potential) beneficial uses and conform to the State’s antidegradation policy; and includes implementation provisions, programs, and policies to protect all waters in the region. In addition, the Basin Plan incorporates all applicable State Water Board and Los Angeles Water Board plans and policies and other pertinent water quality policies and regulations.
- 8.1.2. The Basin Plan incorporates the primary MCLs found in the California Code of Regulations by reference. This incorporation is prospective, including future changes to the incorporated provisions as the changes take effect. Groundwater designated for use as domestic or municipal supply shall not contain concentrations of chemical constituents and radionuclides in excess of the MCLs. The Basin Plan also specifies that groundwaters shall not contain taste or odor-producing substances in concentrations that cause nuisance or adversely affect beneficial uses.
- 8.1.3. The Basin Plan contains water quality objectives for groundwater in the Santa Monica Basin of the Coastal Plain of Los Angeles. The beneficial uses of the receiving groundwater basin are as follows:

TABLE 4. BENEFICIAL USES OF GROUNDWATER

Receiving Water Name	Beneficial Uses
Coastal Plain of Los Angeles (Santa Monica Basin; Department of Water Resources (DWR) Basin No. 4-11.01)	Existing Beneficial Uses: Municipal and domestic water supply (MUN); industrial service supply (IND); industrial process supply (PROC); and agricultural supply (AGR).

- 8.1.4. The Basin Plan water quality objectives for salts in the Santa Monica groundwater basin are:

TABLE 5. GROUNDWATER QUALITY OBJECTIVES FOR SALTS

Basin	DWR Basin No.	TDS (mg/L)	Sulfate (mg/L)	Chloride (mg/L)	Boron (mg/L)
Coastal Plain of Los Angeles Santa Monica	4-11.01	1000	250	200	0.5

8.2 PORTER-COLOGNE WATER QUALITY CONTROL ACT

- 8.2.1. CWC section 13263 requires that the Los Angeles Water Board prescribe requirements as to the nature of any discharge to waters of the State, implementing any relevant water quality control plan and

taking into consideration beneficial uses, water quality objectives, and the need to prevent nuisance.

- 8.2.2. Pursuant to CWC section 13263(g), discharges of waste into water of the state are privileges, not rights. Nothing in this Order creates a vested right to continue the discharge. CWC section 13263 authorizes the Los Angeles Water Board to issue waste discharge requirements that implement any relevant water quality control plan.
- 8.2.3. CWC section 13267 authorizes the Los Angeles Water Board to require technical and monitoring reports. The attached MRP establishes monitoring and reporting requirements to implement federal and state requirements. CWC section 13267(b) states, in part:

“In conducting an investigation specified in subdivision (a), the regional board may require that any person who has discharged, discharges, or is suspected of having discharged or discharging or proposes to discharge within its region, or any citizen or domiciliary, or political agency or entity of this state who has discharged, discharges, or is suspected of having discharged or discharging, or who proposes to discharge waste outside of its region shall furnish under penalty of perjury, technical or monitoring program reports which the Regional Board requires. The burden, including costs of these reports shall bear a reasonable relationship to the need for the reports and the benefits to be obtained from the reports. In requiring those reports, the regional board shall provide the person with a written explanation with regard to the need for the reports and shall identify the evidence that supports requiring that person to provide the reports.”
- 8.2.4. The need for technical and monitoring reports required by this Order, including the MRP, are based on the Report of Waste Discharge (ROWD) and Engineering Report; the recommendations from DDW; and other information in the Los Angeles Water Board’s files for the facility. The technical and monitoring reports are necessary to assure compliance with this Order. The burden, including costs, of providing the technical reports required by this Order bears a reasonable relationship to the need for the reports and the benefits to be obtained from the reports. Specifically, the required monitoring is needed to confirm that operation of the AWTF meets the parameters of this Order and complies with the Basin Plan, thus protecting human health, including drinking water supplies, and the environment.
- 8.2.5. Pursuant to CWC section 13320, any aggrieved party may seek review of this Order by filing a petition with the State Water Board in accordance with CCR, title 23, sections 2050-2068. The State Water Board must receive the petition by 5:00 p.m., 30 days after adoption of this Order, except that if the thirtieth day following the date of this Order falls on a Saturday, Sunday, or State holiday, the petition must be received by the State Water Board by 5:00 p.m. on the next business

day. [Copies of the law and regulations applicable to filing petitions \(http://waterboards.ca.gov/public_notices/petitions/water_quality\)](http://waterboards.ca.gov/public_notices/petitions/water_quality) may be found on the State Water Boards' website.

- 8.2.6. The Los Angeles Water Board has notified the City, interested agencies, and persons of its intent to issue this Order for the production and use of recycled water and has provided them with an opportunity to submit written comments. The Los Angeles Water Board, in a public meeting, heard and considered all comments pertaining to this Order. (CWC section 13263.)

8.3 ANTIDEGRADATION POLICY

- 8.3.1. On October 28, 1968, the State Water Board adopted Resolution No. 68-16, Statement of Policy with Respect to Maintaining High Quality of Waters in California (Resolution 68-16), establishing an Antidegradation Policy for the State Water Board and Regional Water Boards. Resolution 68-16 requires the Los Angeles Water Board, in regulating discharge of waste, to maintain high quality waters of the State until it is demonstrated that any change in quality (1) will be consistent with maximum benefit to the people of the State, (2) will not unreasonably affect beneficial uses, and (3) will not result in water quality less than that prescribed in the Los Angeles Water Board's policies. Resolution 68-16 requires the discharge to be regulated to meet best practicable treatment or control to assure that pollution or nuisance will not occur and the highest water quality consistent with the maximum benefit to the people of the State be maintained. The Los Angeles Water Board's Basin Plan incorporates, by reference, the state antidegradation policy.
- 8.3.2. Section 7.2.2 of the Recycled Water Policy requires that, "for non-potable recycled water projects ineligible or inappropriate for enrollment under statewide water reclamation requirements, project proponents must submit an antidegradation analysis to the Los Angeles Water Board with the report of waste discharge to demonstrate compliance with the Antidegradation Policy." The City submitted an Antidegradation Study on May 05, 2020 and the Los Angeles Water Board requested revisions to the study on July 24, 2020. The City submitted a revised version of the Antidegradation Study on September 29, 2020 and the study adequately evaluates the potential impacts of the proposed activities associated with nonpotable uses of the recycled water in compliance with the Antidegradation Policy.
- 8.3.3. This Order regulates discharges to the SMGB. The SMGB contains high quality water, as described in section 8.3.6 below. To the extent use of recycled water for nonpotable uses may result in the discharge to the SMGB, this Order authorizes limited degradation consistent with the Antidegradation Policy as described in the findings below. The analysis is based on the information provided in the Antidegradation Study dated September 29, 2020. A SNMP is currently being developed for the

Santa Monica subbasin in accordance with the Recycled Water Policy, which will require ongoing analysis to evaluate inputs into the basin, the salt and nutrient mass balance, and the available assimilative capacity.

- 8.3.4. This Order requires best practicable treatment and control, which is a combination of advanced treatment, storage, and application methods that implement the requirements of 22 CCR and the Basin Plan. Recycled water is generated by treating domestic wastewater adequately to make the water suitable for direct beneficial use that would not otherwise occur. The required level of treatment in this Order corresponds to the proposed use of recycled water for nonpotable use. In addition, this Order includes requirements regarding the storage and application of recycled water to protect water quality and to limit public contact with recycled water, as appropriate. These requirements will assure that pollution or nuisance will not occur and the highest water quality consistent with the maximum benefit to the people of the State be maintained.
- 8.3.5. The SWIP, including the AWTF, increases the use of local supplies by reusing water that would otherwise flow to the ocean via the Hyperion Water Reclamation Plant or the storm drain system without supporting beneficial uses during transmission. The use of recycled water in place of potable water supplies for the nonpotable uses allowed under this Order improves local water supply availability and reduces the need to rely on imported water.
- 8.3.6. As part of the Antidegradation Study dated September 29, 2020, the City collected five groundwater samples between 2017 and 2020 and had them analyzed for salts and nutrients. The data collected indicates that the average concentrations of chloride (80 mg/L), sulfate (140 mg/L), TDS (580 mg/L), boron (0.12 mg/L), nitrate (0.8 mg/L), nitrite (0.10 mg/L), and nitrate plus nitrite (0.51 mg/L) in the groundwater are all below the water quality objectives in the Basin Plan for chloride (200 mg/L), sulfate (250 mg/L), TDS (1,000 mg/L), boron (0.5 mg/L), nitrate (10 mg/L), nitrite (1 mg/L), and nitrate plus nitrite (10 mg/L). A conservative estimate (disregarding any impact of dilution by stormwater) of the advanced-treated recycled water concentrations for chloride (28 mg/L), sulfate (3.2 mg/L), TDS (120 mg/L), boron (0.3 mg/L), nitrate (3.9 mg/L), nitrite (<0.1 mg/L), and nitrate plus nitrite (0.9 mg/L) also indicates the water quality objectives in the Basin Plan for salts and nutrients will be achieved. Based on these conservative estimates, the advanced-treated recycled water is expected to have lower concentrations of TDS, chloride, and sulfate but higher concentrations of boron (0.3 mg/L vs 0.12 mg/L), nitrate (3.9 mg/L vs 0.8 mg/L), and nitrate plus nitrite (0.9 mg/L vs 0.51 mg/L) than the current groundwater quality. Since there is limited data on the concentrations of salts and nutrients in the Santa Monica Basin, the above comparisons are only rough estimates and additional

groundwater data is needed to provide an accurate picture of the actual current groundwater quality. The City is in the process of collecting additional groundwater data to support the antidegradation analysis for the indirect potable reuse operations. The additional data will provide a more accurate estimate of the current groundwater quality before recycled water is injected directly into the aquifer. As required by the Antidegradation Policy, the Los Angeles Water Board finds that the limited degradation of groundwater with respect to boron and nitrogen species that may occur as the result of using the advanced-treated recycled water for the nonpotable uses permitted under the conditions of this Order provides maximum benefit to the people of California, provided the recycled water treatment and use are managed to ensure long-term reasonable protection of beneficial uses to waters of the State.

- 8.3.7. 22 CCR imposes limitations on the uses of recycled water, based on the level of treatment and the specific use to protect public health. By restricting the use of recycled water to those meeting the requirements in 22 CCR, this Order ensures the water will be used safely. To the extent that the use of recycled water may result in some waste constituents entering the environment after effective source control, advanced treatment and other control measures are implemented, the conditions of this Order limiting the use of recycled water to agronomic rates is part of the suite of treatment, storage, and application measures that comprise best practical treatment and control for irrigation. Other types of uses that may be approved such as toilet/urinal flushing in dual-plumbed systems, dust control, , and other short-term or infrequent applications are unlikely to result in sufficient loading of waste constituents that impact water quality.
- 8.3.8. Constituents associated with recycled water that have the potential to degrade groundwater include salinity, nutrients, pathogens (represented by coliform bacteria), disinfection byproducts (DBPs), constituents of emerging concern (CECs), and endocrine disrupting chemicals (EDCs). The Los Angeles Water Board finds that the use of recycled water permitted under this Order will not unreasonably affect beneficial uses or result in water quality that is less than that is described in the applicable policies. The characteristics and requirements associated with each of the recycled water constituents of concern are discussed below:
 - a. Salinity is measured in water through various measurements, including but not limited to, total dissolved solids (TDS) and electrical conductivity. Excessive salinity can impair the beneficial uses of water. Salinity levels in the receiving water can be affected by the use of recycled water if the recycled water has elevated concentrations of salinity. This Order requires the advanced-treated recycled water from the AWTF to meet the salinity water quality

objectives for the Santa Monica Groundwater Basin. The AWTF will remove salts using a reverse osmosis system. Although the water delivered to customers for irrigation will be a mixture of advanced-treated recycled water from the AWTF and stormwater and dry-weather runoff treated by the SMURRF, and potable water when alternate water supplies are insufficient to meet the demand, the main source of water will be the advanced-treated recycled water from the AWTF. Since stormwater and dry weather runoff have low salt concentrations and the majority of water used for irrigation is from the AWTF, and the fact that the advanced-treated recycled water is required to meet the water quality objectives for salts, the use of nonpotable water for irrigation in the Land Use area will not impair the beneficial uses of groundwater in the SMGB.

- b. Nitrogen is a nutrient that may be present in recycled water. The AWTF will be designed to remove nitrogen from wastewater using a membrane bioreactor and reverse osmosis system. The AWTF will reduce the concentration of nitrogen compounds below the primary MCLs and Basin Plan objectives, as required in this Order. In addition, this Order requires application of recycled water to take into consideration nutrient levels in recycled water and nutrient demand by plants. Application of recycled water at agronomic rates and considering soil, climate, and plant demand minimizes the movement of nutrients below the plants' root zone. When applied to cropped (or landscaped) land, some of the nitrogen in recycled water will be taken up by the plants, lost to the atmosphere through volatilization of ammonia or denitrification, or stored in the soil matrix. As a result, nitrogen will not impair an existing and/or potential beneficial use of groundwater.
- c. Pathogens and other microorganisms may be present in recycled water based on the disinfection status. Coliform bacteria are used as a surrogate (indicator) because they are present in untreated wastewater, survive in the environment similar to pathogenic bacteria, and are easy to detect and quantify. Pathogens are generally limited in their mobility when applied to land.

The AWTF will include multiple systems that will remove pathogenic microorganisms, including a membrane bioreactor, cartridge filters, reverse osmosis, and UVAOP. The recycled water will meet the pathogenic microorganism requirements for filtered wastewater in 22 CCR § 60301.230.

In addition, setbacks from recycled water use areas are required in 22 CCR as a means of reducing pathogenic risks by coupling pathogen inactivation rates with groundwater travel time to a domestic water supply well or other potential exposure route (e.g. water contact activities). In general, a substantial unsaturated zone

reduces pathogen survival compared to saturated soil conditions. Fine grained soil particles (silt or clay) reduce the rate of groundwater transport and therefore are generally less likely to transport pathogens. Setbacks also provide attenuation of other recycled water constituents through physical, chemical, and biological processes.

- d. Disinfection by-products (DBPs) consist of organic and inorganic substances produced by the interaction of chemical disinfectants with naturally occurring substances in the water source. Common disinfection by-products include trihalomethanes, haloacetic acids, bromate, and chlorite. DBPs present in wastewater will be reduced by treatment at the AWTF and the recycled water will receive additional treatment when applied to land. Biodegradation, adsorption, volatilization, and other attenuative processes that occur naturally in soil will reduce the concentrations and retard migration of DBPs in the subsurface.
- e. Chemicals of Emerging Concern (CECs) in recycled water as defined in the Recycled Water Policy are chemicals in personal care products, pharmaceuticals including antibiotics, antimicrobials; industrial, agricultural, and household chemicals; hormones; food additives; transformation products, inorganic constituents; and nanomaterials. CECs are new classes of chemicals, diverse, and relatively unmonitored chemicals. Many of them are so new that standardized measurement methods and toxicological data for interpreting their potential human or ecosystem health effects are unavailable. The State Water Board convened a CEC Advisory Panel to address questions about regulating CECs with respect to the use of recycled water. The Panel's primary charge was to provide guidance for developing monitoring programs that assess potential CEC threats from various water recycling practices, including groundwater recharge/reuse and urban landscape irrigation. The Panel provided recommendations for monitoring specific CECs in recycled water used for groundwater recharge reuse. Monitoring of health-based CECs or performance indicator CECs is not required for recycled water used for landscape irrigation and other nonpotable uses due to the low risk of ingestion of the water; however the RO system of the AWTF will reduce the concentration of CECs in the recycled water. The CEC monitoring recommendations were made part of the Recycled Water Policy and since this Order does not provide coverage for groundwater recharge activities, CEC monitoring is not required in this Order.
- f. Endocrine disrupting chemicals (EDCs) are mostly man-made, found in various materials such as pesticides, metals, additives, or contaminants in food, and personal care products. Human exposure to EDCs occurs via ingestion of food, dust and water, via inhalation

of gases and particles in the air, and through the skin. Perchlorate is an EDC that may be present in hypochlorite solutions, which is a type of disinfectant used to treat the recycled water from the AWTF. Formation of perchlorate in hypochlorite solution can be minimized when proper manufacturing, handling, and storage conditions are followed. Perchlorate accumulation has been documented in fruit and seed-bearing crops and leafy vegetation irrigated with perchlorate contaminated water. Recycled water currently makes up less than one percent of California agricultural water supply. Much of the recycled water used for agricultural irrigation is either undisinfected or is disinfected by means that do not result in perchlorate generation, such as ultraviolet light and chlorine gas. The AWTF will disinfect the recycled water using ultraviolet light in addition to sodium hypochlorite. Some sources of agricultural water supply in some areas of the state contain perchlorate, such as surface water from Colorado River or groundwater sources in areas near industrial or military application sites (e.g. Riverside, San Bernardino, and Los Angeles counties). The blending of sources of irrigation water will further reduce any concentration of perchlorate present in recycled water and will be unlikely to affect beneficial uses or degrade groundwater quality. In addition, the RO system of the AWTF will reduce the concentration of EDCs in the recycled water prior to distribution.

- 8.3.9. Using recycled water for nonpotable reuse is to the maximum benefit to the people of the State. The use of recycled water for irrigation and dual-plumbed systems reduces the region's dependence on imported potable water.
- 8.3.10. With regard to the land application areas, application of recycled water for irrigation is limited to agronomic rates and therefore is not expected to measurably impact groundwater quality or lead to any degradation. To further limit the extent of any degradation, the recycled water is also required to meet the groundwater quality objectives in the Basin Plan for salts and nutrients. To the extent there is any degradation, the use of recycled water for irrigation is to the maximum benefit to the people of the State and the application in accordance with agronomic rates, in addition to the advanced treatment provided by the AWTF, constitutes best practicable treatment and control.

8.4. CALIFORNIA ENVIRONMENTAL QUALITY ACT (CEQA) AND NOTIFICATION

A draft Initial Study/ Mitigated Negative Declaration (IS/MND) for the SWIP was circulated for a 30-day public review from July 19, 2016 to August 20, 2016. City staff prepared written responses to all comments and presented those comments and responses in the final IS/MND. The final IS/MND determined that the proposed SWIP would not result in significant impacts to the

environment with the incorporation and implementation of mitigation measures in the areas of biological resources, cultural resources, and construction effects. Mitigation measures include the use of cultural resource monitors during earth-disturbing activities and biological resource monitoring (birds and bats) during construction. Construction effects will be mitigated by adherence to City Municipal Code pertaining to work hours. Less than significant or no impacts would occur with respect to aesthetics/shadows, agriculture and forestry resources, air quality, greenhouse gas emissions, hydrology and water quality, land use and planning, mineral resources, population and housing, and public services, utilities, and mandatory findings of significance. To ensure mitigation measures are properly implemented, a Mitigation Monitoring and Reporting Program has been prepared and will be executed during construction and operation of the SWIP. The proposed mitigation measures are provided in the final IS/MND. The final IS/MND, the Mitigation Monitoring and Reporting Plan and the National Environmental Policy Act (NEPA) documents (i.e. CEQA-Plus) for the SWIP were certified by the Santa Monica City Council on September 27, 2016, and the Notice of Determination was filed at the State Clearinghouse on September 30, 2016.

The Los Angeles Water Board, as a responsible agency under CEQA, finds that all environmental effects have been identified for project activities that it is required to approve, and that the Project will not have significant adverse impacts on the environment provided that the mitigation presented in the final CEQA-Plus documents, is carried out as conditioned in this Order. In adopting this Order, the Los Angeles Water Board has eliminated or substantially lessened the less-than-significant effects on water quality, and therefore approves the project.

8.5. SAFE DRINKING WATER ACT

Pursuant to CWC section 106.3, it is the policy of the State of California that every human being has the right to safe, clean, affordable, and accessible water adequate for human consumption, cooking, and sanitary purposes. This Order promotes that policy by reducing the demand for potable water and requiring that the advanced-treated water meets all applicable effluent limits to protect human health.

THEREFORE, IT IS HEREBY ORDERED that in order to meet the provisions contained in division 7 of the CWC (commencing with section 13000) and regulations and guidelines adopted thereunder, and CCR, title 22, division 4, chapter 3, the City shall comply with the requirements in this Order.

1. INFLUENT SPECIFICATIONS

The influent to the AWTF shall be raw wastewater, stormwater, and dry-weather runoff from the City of Santa Monica as described in this Order. The raw wastewater is primarily from residential and commercial users. The City of Santa

Monica shall maintain an active pretreatment program to control pollutants that may interfere with treatment or pass through the AWTF.

2. RECYCLED WATER TREATMENT SPECIFICATIONS

Treatment of recycled water shall be as described in the findings of this Order and as described in DDW’s conditional approval letter issued on August 19, 2020 (Attachment F).

3. RECYCLED WATER DISCHARGE LIMITATIONS

Refer to section 4 of this Order for additional information concerning the rationale for the limitations for turbidity, total coliform, salts, and nutrients.

3.1. Nonpotable Uses

The advanced-treated recycled water produced at the AWTF for nonpotable uses such as landscape irrigation and dual-plumbed systems shall not contain pollutants in excess of the following limitations, with compliance measured at Monitoring Location EFF-001 as described in the MRP, Attachment E.

TABLE 6. DISCHARGE LIMITATIONS NONPOTABLE USES

Constituents	Units	Average Monthly	7-day Median	Maximum Daily	Instantaneous Minimum	Instantaneous Maximum	Notes
Oil and Grease	mg/L	10	---	15	---	---	---
Total Coliform	MPN/100 mL	23	2.2	---	---	240	Note a
pH	Units	---	---	---	6.5	8.5	---
Turbidity (after MF and prior to RO)	NTU	---	---	0.2	---	0.5	Note b
Total Dissolved Solids	mg/L	---	---	1,000	---	---	---
Chloride	mg/L	---	---	200	---	---	---
Sulfate	mg/L	---	---	250	---	---	---
Boron	mg/L	---	---	0.5	---	---	---
Nitrate-N + Nitrite-N	mg/L	---	---	10	---	---	---
Nitrate as Nitrate	mg/L	---	---	45	---	---	---
Nitrate as Nitrogen	mg/L	---	---	10	---	---	---
Nitrite as Nitrogen	mg/L	---	---	1	---	---	---

Footnotes for Table 6

- a. The median concentration of total coliform bacteria measured in the disinfected effluent shall not exceed an MPN of 2.2 per 100 milliliters utilizing the bacteriological results of the last seven days for which analyses have been completed and the number of total coliform bacteria shall not exceed an MPN of 23 per 100 milliliters in more than one sample in any 30-day period. No sample shall exceed an MPN of 240 total coliform per 100 milliliters (22 CCR § 60301.230).
- b. The turbidity of the MBR filtrate shall not exceed any of the following: 1) 0.2 NTU more than 5% of the time (72 minutes) within a 24-hour period, 2) 0.5 NTU at any time (22 CCR § 60301.320).

End Footnotes for Table 6

3.2. Subsurface Application (Not Applicable)

4. RATIONALE FOR DISCHARGE LIMITATIONS

4.1. Turbidity

Turbidity is an expression of the optical property that causes light to be scattered in water due to particulate matter such as clay, silt, organic matter, and microscopic organisms. The turbidity discharge limitations are based on the definition of filtered wastewater in 22 CCR § 60301.320.

4.2. Total Coliform

Total coliform bacteria are used to indicate the likelihood of pathogenic bacteria in groundwater. The total coliform discharge limitations in this Order for nonpotable uses are based on the definition of disinfected tertiary recycled water in 22 CCR § 60301.230.

4.3. TDS, Chloride, Sulfate, and Boron

Human activities and land use practices can influence inorganic constituents in groundwater. Abnormally high levels of inorganic constituents (such as TDS, chloride, sulfate, and boron) can impair and preclude beneficial uses. The discharge limitations for TDS, chloride, sulfate, and boron are equivalent to the numeric mineral water quality objectives for the Santa Monica Groundwater Basin in Table 3-13 of the Basin Plan. These final effluent imitations are also within the secondary MCL "Consumer Acceptance Contaminant Level Ranges" in 22 CCR § 64449 (for TDS, chloride, and sulfate) and below the notification level for boron.

4.4. Nitrogen Compounds

High nitrate levels in drinking water can cause health problems in humans. Infants are particularly sensitive and can develop methemoglobinemia (blue-baby syndrome). Human activities and land use practices can also influence the nitrogen concentration in groundwater. The discharge limitations in this Order for nitrate, nitrite, and the sum of nitrate and nitrite are based on the

regional objectives for groundwater in the Basin Plan and the MCLs for nitrate, nitrite, and the sum of nitrate and nitrite in 22 CCR § 64431.

5. GENERAL REQUIREMENTS

- 5.1. Bypass, discharge, or delivery to the use area of inadequately treated recycled water, at any time, is prohibited.
- 5.2. The recycling facility shall be adequately protected from inundation and damage by storm flows.
- 5.3. Recycled water use or disposal shall not result in earth movement in geologically unstable areas.
- 5.4. Adequate freeboard and/or protection shall be maintained in any recycled water storage tanks, process tanks, and impoundments to ensure direct rainfall will not cause overtopping.
- 5.5. The AWTF shall not be the source of pollution or nuisance at any time outside the boundary of the facility, including odors that unreasonably affect beneficial uses, odors injurious to health, or odors offensive to the senses of members of the community.
- 5.6. The wastewater treatment and use of recycled water shall not result in problems caused by breeding of mosquitoes, gnats, midges, or other pests.
- 5.7. The use of recycled water shall not impart tastes, odors, color, foaming, or other objectionable characteristics to the receiving groundwater.
- 5.8. Recycled water shall not contain any substance in concentrations toxic to human, animal, or plant life.
- 5.9. Odors of sewage origin shall not be perceivable beyond the limits of the property owned or controlled by the City and/or recycled water user.
- 5.10. The City shall always properly operate and maintain all treatment facilities and control systems (and related appurtenances) which are installed or used by the City to achieve compliance with the conditions of this Order. Proper operation and maintenance include effective performance, adequate funding, adequate operator staffing and training, and adequate laboratory and process controls (including appropriate quality assurance procedures).
- 5.11. A copy of these requirements shall be maintained at the AWTF and shall always be available to operating personnel.
- 5.12. The City shall furnish each user of recycled water a copy of these requirements and ensure that the requirements are maintained at the user's facility and always available to operating personnel.
- 5.13. Supervisors and operators of this publicly owned wastewater treatment facility shall possess a certificate of appropriate grade as specified in CCR, title 23, Division 3, Chapter 26.

5.14. For any material change or proposed change in character, location, or volume of recycled water, or its uses, the City shall submit, at least 120 days prior to the proposed change, an engineering report or addendum to the existing engineering report to the Los Angeles Water Board and DDW (pursuant to CWC section 13522.5 and 22 CCR § 60323) for approval. The Engineering Report shall be prepared by a qualified engineer registered in California. This updated engineering report shall describe the current treatment plant, the impacts on the recycled water operation, and contain the operation and maintenance management plan, including a preventive (fail-safe) procedure and contingency plan for controlling accidental discharge and/or delivery to users of inadequately treated recycled water.

5.15. Climate Change Effects Vulnerability Assessment and Mitigation Plan

On March 07, 2017 the State Water Board adopted Resolution No. 2017-0012 recognizing the challenges posed by climate change that require a proactive approach in all State Water Board actions, including drinking water regulation, water quality protection, and financial assistance. The resolution lays the foundation for a response to climate change that is integrated into all State Water Board actions by providing direction to the State Water Board divisions and encouraging coordination with the regional water boards. In addition to the State Water Board's resolution (No. 2017-0012, the Los Angeles Regional Water Board adopted Resolution No. R18-004, "A Resolution to Prioritize Actions to Adapt to and Mitigate the Impacts of Climate Change on the Los Angeles Region's Water Resources and Associated Beneficial Uses" on May 10, 2018. The resolution summarizes the steps taken so far to address the impacts of climate change within the Los Angeles Water Board's programs and lists a series of steps to move forward. These include the identification of potential regulatory adaptation and mitigation measures that could be implemented on a short-term and long-term basis by each of the Los Angeles Water Board's programs to take into account, and assist in mitigating where possible, the effects of climate change on water resources and associated beneficial uses. This Order contains provisions to require planning and actions to address climate change impacts in accordance with both the State and Los Angeles Water Board resolutions.

The City shall consider the impacts of climate change as they affect the operation of the AWTF, the collection system, and the recycled water distribution system due to flooding, wildfire, or other climate-related changes. The City shall develop a Climate Change Effects Vulnerability Assessment and Mitigation Plan (Climate Change Plan) to assess and manage climate change-related effects that may impact the wastewater treatment facility's operation, water supplies, its collection system, and water quality, including any projected changes to the influent water temperature and pollutant concentrations, beneficial uses, as well as the impact of rising sea level (where applicable). The Climate Change Plan is due 12 months after the effective date of this Order.

6. SPECIFICATIONS FOR USE OF RECYCLED WATER

6.1. The treated water from the AWTF may be used for the following nonpotable uses:

6.1.1. Surface irrigation in the following areas:

- Food crops, including all edible root crops, where the recycled water comes into contact with the edible portion of the crop;
- Parks and playgrounds;
- School yards;
- Residential and freeway landscaping;
- Unrestricted and restricted access golf courses;
- Cemeteries;
- Decorative fountains
- Ornamental nursery stock where the public is not restricted; and
- Other allowable irrigation applications specified in 22 CCR provided approval from DDW and the Los Angeles Water Board Executive Officer prior to delivery.

6.1.2. A dual-plumbed system may be used to deliver recycled water to end users. The detailed dual-plumbed system requirements are included in Section 8 of this Order.

6.2. Recycled water shall be managed in conformance with the applicable regulations contained in 22 CCR.

6.3. Recycled water shall not be used for direct human consumption or for the processing of food or drink intended for human consumption.

6.4. The delivery of recycled water to end users shall be subject to DDW approval and/or its delegated local agency.

6.5. The recycled water shall not be used for any other uses than those specified above unless an engineering report has been submitted for those uses and has been approved in writing by the Executive Officer and DDW.

6.6. Recycled water shall be retained in the areas of use and shall not be allowed to escape as surface flow except as authorized under an NPDES permit.

7. USE AREA REQUIREMENTS

Use area is an area of recycled water use with defined boundaries, which may contain one or more facilities where recycled water is used. The City shall ensure that all users of recycled water comply with the following:

7.1. All use areas where recycled water is used that are accessible to the public shall be posted with signs that are visible to the public no less than 4 inches high by 8 inches wide that include the following wording, "RECYCLED

- WATER – DO NOT DRINK.” Each sign shall display an international symbol to alert people who do not read English.
- 7.2. No physical connection shall be made or allowed to exist between any recycled water piping and any piping conveying potable water, except as allowed under 17 CCR § 7604.
 - 7.3. The portions of the recycled water piping system that are in areas subject to access by the general public shall not include any hose bibbs. Only quick couplers that differ from those used on the potable water system shall be used on the portions of the recycled water piping system in areas subject to public access.
 - 7.4. No impoundment or storage ponds containing disinfected recycled water shall occur within 100 feet of any domestic water wells, potable water reservoirs, and streams used as sources of water supply.
 - 7.5. Whenever a cooling system uses recycled water in conjunction with an air conditioning facility and utilizes a cooling tower or otherwise creates a mist that could contact employees or members of the public, the cooling system shall comply with the following:
 - 7.5.1. A drift eliminator shall be used whenever the cooling system is in operation.
 - 7.5.2. Chlorine or another biocide shall be used to treat the cooling system recirculating water to minimize the growth of *Legionella* and other microorganisms.
 - 7.6. No recycled water irrigation areas shall be located within 50 feet of any domestic supply well unless all the following conditions have been met:
 - 7.6.1. A geological investigation demonstrates that an aquitard exists at the well between the uppermost aquifer being drawn from and the ground surface;
 - 7.6.2. The well contains an annular seal that extends from the surface into the aquitard;
 - 7.6.3. The well is housed to prevent any recycled water spray from contacting the wellhead facilities;
 - 7.6.4. The ground surface immediately around the wellhead is contoured to allow surface water to drain away from the wellhead;
 - 7.6.5. The owner of the well approves of the elimination of the buffer zone requirement.
 - 7.7. No irrigation shall take place within 50 feet of any reservoir or stream used as a source of domestic drinking water.
 - 7.8. Recycled water shall be applied at agronomic rates. Special precautions must be taken to prevent clogging of spray nozzles, prevent over watering,

- and to minimize the production of runoff. Pipelines shall be maintained to prevent leakage.
- 7.9. Any irrigation runoff shall be confined to the recycled water use area and shall not be allowed to escape as surface flow, unless the runoff does not pose a public health threat and is authorized under an NPDES permit, Waste Discharge Requirements, a Conditional Waiver of Waste Discharge Requirements for Irrigated Lands, or other orders issued by the State or Los Angeles Water Board. For the purpose of this requirement, however, minor amounts of irrigation return water from peripheral areas shall not be considered a violation of this Order.
 - 7.10. Spray, mist, or runoff shall not enter dwellings, designated outdoor eating areas, or food handling facilities, and shall not contact any drinking water fountain and public present. Drinking water fountains must be equipped with hoods or covers.
 - 7.11. Recycled water shall not be used for irrigation during periods of rainfall and/or runoff.
 - 7.12. All above-ground irrigation appurtenances need to be marked appropriately.
 - 7.13. The area using recycled water shall be inspected annually by the City.
 - 7.14. Supervisors shall be appointed for the recycled water use areas and their staff shall be trained on the hazards of working with recycled water and periodically retrained.
 - 7.15. The City shall maintain User Agreements and Ordinances with the potential agricultural, industrial, and recreational users of recycled water. Copies of the User Agreements and Ordinances shall be provided to the Los Angeles Water Board and DDW for review within 90 days of the effective date of this Order.
 - 7.16. If the recycled water system lateral pipelines are located along the property lines of homeowners, there may be a potential for cross connections. A buffer zone between the recycled water lines and the property owners is necessary. If the City cannot maintain adequate control of the recycled water system pipelines, the pipelines need to be relocated or a physical barrier needs to be installed to prevent cross connections, and the City shall implement a public outreach program to inform the public.
 - 7.17. For each new/proposed recycled water use area, a use site report that addresses compliance with the use area requirements and includes results of a completed shut-down test shall be submitted to the Los Angeles Water Board and to DDW for approval.
 - 7.18. The use and distribution of recycled water shall comply with DDW's CCR, title 22, Division 4, Chapter 3 - *Water Recycling Criteria*; and the CCR, title 17, Division 1, Chapter 5, Subchapter 1, Group 4, Cross-Connection Control Requirements.

- 7.19. All back-up/ auxiliary potable supplies shall discharge through approved air-gaps or swivel-ell connections with approved backflow prevention on the potable supply line. Back-up/auxiliary supply piping plans shall be submitted and reviewed by DDW and/or its delegated local agency. A certified tester shall test all backflow devices annually. Air gaps shall be at least twice the pipe diameter and be located above ground. Swivel-ell connections shall be controlled by the domestic water supplier. The use site agreements shall include conditions that clarify the control and operation of swivel-ell connections.
- 7.20. All recycled water pipelines and valves shall be installed with purple identification tape or purple polyethylene vinyl wraps according to the American Water Works Association's (AWWA) California-Nevada Section guidelines. Adequate separation of at least 4-foot horizontal and 1-foot vertical separation shall be provided between recycled water lines and domestic potable water lines.
- 7.21. Plans and maps showing domestic water lines and recycled water lines at each use site shall be maintained. The lines shall be marked clearly and labeled as domestic water lines and recycled water lines. Shut-down tests may be needed to demonstrate that cross-connections do not exist.
- 7.22. Incidental runoff from landscape irrigation shall be controlled through the following practices:
 - Implementation of an operations and management plan that may apply to multiple sites and provides for detection of leaks, (for example, from broken sprinkler heads), and correction either within 72 hours of learning of the runoff, or prior to the release of 1,000 gallons, whichever occurs first,
 - Proper design and aim of sprinkler heads,
 - Refraining from application during precipitation events, and
 - Management of any ponds containing recycled water such that no discharge occurs unless the discharge is otherwise regulated pursuant to an NPDES permit.

8. SPECIFICATIONS AND REQUIREMENTS FOR DUAL-PLUMBED SYSTEMS

- 8.1. The public water supply shall not be used as a backup or supplemental source of water for a dual-plumbed recycled water system unless the connection between the two systems is protected by an air gap separation which complies with the requirements of CCR title 17, sections 7602 (a) and 7603 (a), and that such connection has been approved by DDW and/or its delegated local agency.
- 8.2. The City shall not deliver recycled water to a facility using a dual-plumbed system unless the report of recycled water use, required pursuant to CWC section 13522.5, and which meets the requirements set forth in this Order,

has been submitted and approved by DDW and/or its delegated local agency. The Los Angeles Water Board shall be furnished with a copy of DDW approval together with the aforementioned report within 30 days following the approval.

8.3. The report of recycled water use, submitted pursuant to CWC section 13522.5, shall contain the following information for dual-plumbed systems, in addition to the information required by 22 CCR § 60323 (Engineering Report):

8.3.1. A detailed description of the intended use site identifying the following:

- The number, location, and type of facilities within the use area proposing to use dual-plumbed systems;
- The average daily number of persons estimated to be served by each facility;
- The specific boundaries of the proposed use site including a map showing the location of each facility to be served;
- The person or persons responsible for operation of the dual-plumbed system at each facility; and,
- The specific use to be made of the recycled water at each facility.

8.3.2. Plans and specifications describing the following:

- Proposed piping system to be used;
- Pipe locations of both the recycled and potable systems;
- Type and location of the outlets and plumbing fixtures that will be accessible to the public; and,
- The methods and devices to be used to prevent backflow of recycled water into the public water system.

8.3.3. The methods to be used by the City to assure that the installation and operation of the dual-plumbed system will not result in cross connections between the recycled water piping system and the potable water piping system. These shall include a description of pressure, dye or other test methods to be used to test the system every four years.

8.3.4. Prior to the initial operation of the dual-plumbed recycled water system and annually thereafter, the dual-plumbed system within each facility and use site shall be inspected for possible cross connections with the potable water system. The recycled water system shall also be tested for possible cross connections at least once every four years. The testing shall be conducted in accordance with the method described in the report submitted

pursuant to 22 CCR § 60314. The inspections and the testing shall be performed by a cross connection control specialist certified by the California-Nevada Section of the AWWA or an organization with equivalent certification requirements. A written report documenting the result of the inspection and testing for the prior year shall be submitted to DDW within 30 days following completion of the inspection or test.

- 8.3.5. The City shall notify DDW of any incidence of backflow from the dual-plumbed recycled water system into the potable water system within 24 hours of discovery of the incident.
- 8.3.6. Any backflow prevention device installed to protect the public water system serving the dual-plumbed recycled water system shall be inspected and maintained in accordance with CCR, title 17, section 7605.

9. DDW SPECIFICATIONS AND REQUIREMENTS

The City shall comply with the requirements set forth in DDW's conditional acceptance letter to the Los Angeles Water Board dated August 19, 2020, as listed below:

- 9.1. Prior to start of operation and delivery of recycled water, an Operations and Maintenance Manual (OMM) shall be submitted to DDW for review and acceptance. The OMM shall include at a minimum: process optimization, alarm set points, diversion and off-spec contingencies, and instrument calibration and maintenance.
- 9.2. The City shall submit an updated Engineering Report to DDW for review and acceptance if any changes to the information provided in the current report are considered in the future.
- 9.3. Sampling of the recycled water for total coliform bacteria shall be conducted daily in accordance with 22 CCR § 60301.230.
- 9.4. Each ultraviolet (UV) disinfection train shall be operated independently to deliver a minimum validated UV dose of 300 mJ/cm² at all times.
- 9.5. Continuous turbidity monitoring in the recycled water shall be conducted in accordance with the requirements specified in 22 CCR § 60301.320.
- 9.6. A monthly summary of operating records including analyses, records of operational problems, plant and equipment breakdowns, and diversions to emergency storage or disposal, and all corrective and preventative actions taken shall be filed monthly with the Los Angeles Water Board as required in 22 CCR § 60329.
- 9.7. At startup of the AWTF, the City shall conduct a demonstration of the critical alarms that would trigger an immediate diversion to take place as stated in the report. The City must notify DDW when this demonstration is

scheduled to take place and DDW's staff may witness the critical alarms testing.

- 9.8. Prior to delivery of recycled water to any use sites not owned by the City, the City shall develop and adopt enforceable rules and regulations that cover design, construction, operation, maintenance, and control measures of the recycled water use areas.
- 9.9. The City shall submit a supplementary Engineering Report along with all necessary information and drawings for new recycled water use sites in the future for review and acceptance by DDW.
- 9.10. Prior to delivery of recycled water to any dual-plumbed recycled water systems, plans and specifications for any dual-plumbed facilities must be submitted to DDW for review and acceptance in accordance with 22 CCR § 60314. The proposed plans and specifications must be in accordance with the requirements in 22 CCR § 60313 through 60316.

10. ADDITIONAL PROVISIONS

- 10.1. Irrigation of recycled water shall not cause or contribute to an exceedance of the Basin Plan water quality objectives.
- 10.2. The City shall submit plans for proposed and as-built drawings for recycled water projects to and obtain approval from DDW or its delegated local health agency for each recycled water project. The *AWWA Guidelines for the Distribution of Non-Potable Water* shall be followed, including installation of purple pipe, adequate signs, etc. As-built drawings shall show the final locations of the potable water, sewer, and recycled water pipelines, and indicate adequate separation between the recycled water and potable domestic water lines, both of which shall also be marked clearly or labeled using separate colors for identification. In addition, a copy of each application to DDW for a recycled water project shall be delivered to the Los Angeles Water Board for inclusion in the administrative file with the following information:
 - 10.2.1. A description of each use area including, but not limited to, a description of what will be irrigated (e.g., landscape, specific food crop, etc.); method of irrigation (e.g., spray, flood, or drip); the location of domestic water supply facilities adjacent to the use areas; site containment measures; the party responsible for the distribution and use of the recycled water at the site; and, identification of other governmental entities which may have regulatory jurisdiction over the reuse site(s); and,
 - 10.2.2. A map showing specific areas of use, areas of public access, surrounding land uses, the location and construction details of wells in or near the use areas, the location and type of signage, the degree of potential access by employees or the public, and any exclusionary measures (e.g. fencing). The City shall submit to

the Los Angeles Water Board a copy of the approved Recycled Water Project for the recycled water distribution system and DDW approval within 30 days of approval.

- 10.3. For any extension or expansion of the recycled water system or use areas not covered by the 2020 Engineering Report, the City shall submit a report detailing the extension or expansion plan for review and approval by DDW or its delegated local health agency, and the Los Angeles Water Board. The plan shall include, but not be limited to, the information specified in Sections 10.2.1 and 10.2.2., above. Following construction, as-built drawings shall be submitted to DDW or its delegated local health agency for approval prior to delivery of recycled water. The City shall submit to the Los Angeles Water Board a copy of the approved expansion plan and DDW approval within 30 days of approval.
- 10.4. If the recycled water system lateral pipelines are located on an easement contiguous to a homeowner's private property and where there is a reasonable probability that an illegal or accidental connection to the recycled water line could be made, the City shall provide a buffer zone or other necessary measures between the recycled water lines and the easement to prevent any illegal or accidental connection to the recycled water lines. The City shall notify homeowners about the recycled water lateral and restrictions on usage of recycled water.
- 10.5. The City shall inspect the recycled water use areas on a periodic basis. The City shall update the inspection schedule, based on the type of use site, for approval by DDW within 90 days of the effective date of this Order. An annual report including the findings of each inspection shall be submitted to DDW, the County Health Department, and the Los Angeles Water Board.
- 10.6. The City shall submit to the Los Angeles Water Board, signed under penalty of perjury by the designated responsible party, technical self-monitoring reports according to the specifications contained in the Monitoring and Reporting Program, as may be amended by the Executive Officer.
- 10.7. The City shall notify this Los Angeles Water Board and DDW, immediately by telephone, of any confirmed coliform counts that could cause a violation of the requirements. This information shall be confirmed in the following monitoring report. For any actual coliform limit violation that occurred, the report shall also include the cause(s) of the high coliform counts, the corrective measures undertaken (including dates thereof), and the preventive measures undertaken to prevent a recurrence.
- 10.8. This Order does not exempt the City from compliance with any other laws, regulations, or ordinances which may be applicable; it does not legalize the recycling and use facilities; and it leaves unaffected any further constraint on the use of recycled water at certain site(s) that may be contained in other statutes or required by other agencies.

- 10.9. This Order does not alleviate the responsibility of the City to obtain other necessary local, state, and federal permits to construct facilities necessary for compliance with this Order; nor does this Order prevent imposition of additional standards, requirements, or conditions by any other regulatory agency. Expansion of the recycled water distribution facility shall be contingent upon issuance of all necessary requirements and permits, including a conditional use permit.
- 10.10. The City shall furnish, within a reasonable time, any information the Los Angeles Water Board or DDW may request to determine whether cause exists for modifying, revoking and reissuing, or terminating this Order. Upon request, the City shall also furnish the Los Angeles Water Board with copies of records required to be kept under this Order for at least three years.
- 10.11. This Order includes the attached *Standard Provisions Applicable to Waste Discharge Requirements* (Attachment D). If there is any conflict between the provisions stated in this Order and the Standard Provisions, the provisions stated in this Order shall prevail.
- 10.12. This Order includes the attached Monitoring and Reporting Program No. CI-10569 (Attachment E). If there is any conflict between provisions stated in the Monitoring and Reporting Program and the Standard Provisions, those provisions stated in the Monitoring and Reporting Program prevail.
- 10.13. In an enforcement action, it shall not be a defense for the City that it would have been necessary to halt or to reduce the permitted activity in order to maintain compliance with this Order. Upon reduction, loss, or failure of the treatment facility, the City shall, to the extent necessary to maintain compliance with this Order, control production or all discharges, or both, until the facility is restored, or an alternative method of treatment is provided. This provision applies, for example, when the primary source of power of the treatment facility fails, is reduced, or is lost.

11. REOPENER

- 11.1. This Order may be modified, revoked and reissued, or terminated for cause, including but not limited to: (1) failure to comply with any condition in this Order, (2) endangerment of human health or environment resulting from the permitted activities in this Order, (3) obtaining this Order by misrepresentation or failure to disclose all relevant facts, or (4) new information that justifies the application of different conditions. The filing of a request by the City for modification, revocation and reissuance, or termination of the Order or a notification of planned changes or anticipated noncompliance does not stay any condition of this Order.
- 11.2. This Order may be reopened to include the most scientifically relevant and appropriate limitations for this discharge, including a revised Basin Plan limit based on monitoring results, studies, or other Board policy, or the

application of an attenuation factor based upon an approved site-specific attenuation study.

- 11.3. This Order may be reopened to modify limitations for constituents to protect beneficial uses, based on new information not available at the time this Order was adopted.
- 11.4. If after additional monitoring, reporting, and trend analysis documenting changed aquifer conditions, this Order may be reopened to ensure the groundwater is protected in a manner consistent with the state and federal water quality laws and regulations.
- 11.5. This Order may be reopened to incorporate any new regulatory requirements for sources of drinking water that are adopted after the effective date of this Order.
- 11.6. This Order may be reopened upon a determination by DDW that treatment and disinfection of recycled water is insufficient to protect human health.

12. ENFORCEMENT

- 12.1. The requirements of this Order are subject to enforcement under Water Code sections 13261, 13264, 13265, 13268, 13300, 13301, 13304, 13350, and enforcement provisions in Water Code, Division 7, Chapter 7 (Water Reclamation).
- 12.2. The City is subject to the terms and conditions of this Order.

ATTACHMENT A – DEFINITIONS

Added Tracer

A non-reactive substance, with measurable characteristics distinctly different from the receiving groundwater, intentionally added to the water applied at a GRRP for the purpose of being a tracer such that the tracer can be readily identified in the groundwater downgradient of the GRRP to determine the underground retention time of the applied water.

Advanced Treated Recycled Water

In this permit, it refers to the treated recycled water produced by the Advanced Water Treatment Facility (AWTF).

Agronomic Rate

The rate of application of recycled water to plants necessary to satisfy the plants' evapotranspiration requirements, considering allowances for supplemental water (e.g., effective precipitation), irrigation distribution uniformity, and leaching requirement, thus minimizing the movement of nutrients below the plants' root zone.

Arithmetic Mean (μ)

Also called the average, is the sum of measured values divided by the number of samples.

Average Monthly Effluent Limitation (AMEL)

The highest allowable average of daily discharges over a calendar month, calculated as the sum of all daily discharges measured during the calendar month divided by the number of daily discharges measured during that month.

Average Weekly Effluent Limitation (AWEL)

The highest allowable average of daily discharges over a calendar week (Sunday through Saturday), calculated as the sum of all daily discharges measured during a calendar week divided by the number of daily discharges measured during that week.

Coagulated Wastewater

Oxidized wastewater in which colloidal and finely divided suspended matter have been destabilized and agglomerated upstream from a filter by the addition of suitable flocculating chemicals.

Composite Sample, 24-hour

An aggregate sample derived from no fewer than eight samples collected at equal time intervals or collected proportional to the flow rate over the compositing period. The aggregate sample shall reflect the average source water quality covering the composite 24-hour sample period.

Conventional Treatment

A treatment chain that utilizes a sedimentation unit process between the coagulation and filtration processes and produces an effluent that meets the definition for disinfected tertiary recycled water.

Daily Discharge

Daily Discharge is defined as either: (1) the total mass of a constituent discharged over the calendar day (12:00 am through 11:59 pm) or any 24-hour period that reasonably represents a calendar day for purposes of sampling (as specified in the permit), for a constituent with limitations expressed in units of mass or; (2) the unweighted arithmetic mean measurement of the constituent over the day for a constituent with limitations expressed in other units of measurement (e.g., concentration).

The daily discharge may be determined by the analytical results of a composite sample taken over the course of one day (a calendar day or other 24-hour period defined as a day) or by the arithmetic mean of analytical results from one or more grab samples taken over the course of the day.

For composite sampling, if 1 day is defined as a 24-hour period other than a calendar day, the analytical result for the 24-hour period will be considered as the result for the calendar day in which the 24-hour period ends.

Detected, but Not Quantified (DNQ)

DNQ are those sample results less than the RL, but greater than or equal to the laboratory's MDL. Sample results reported as DNQ are estimated concentrations.

Diluent Water

"Diluent Water" means water, meeting the diluent requirements of chapter 3, division 4 of Title 22 of the California Code of Regulations, used for reducing the recycled municipal wastewater contribution over time.

Disinfected Secondary-2.2

Recycled water that has been oxidized and disinfected so that the median concentration of total coliform bacteria in the disinfected effluent does not exceed a most probable number (MPN) of 2.2 per 100 milliliters utilizing the bacteriological results of the last seven days for which analyses have been completed, and the number of coliform organisms does not exceed an MPN of 23 per 100 milliliters in more than one sample in any 30-day period.

Disinfected Tertiary Recycled Water

A filtered and subsequently disinfected wastewater that meets the following criteria:

- (a) The filtered wastewater which has been disinfected by either:
 - (1) A chlorine disinfection process following filtration that provides a contact time (CT, the product of total chlorine residual and modal contact time measured at the same point) value of not less than 450 milligram-minutes per liter at all

times with a modal contact time of at least 90 minutes, based on peak dry weather design flow; or

- (2) A disinfection process that, when combined with the filtration process, has been demonstrated to inactivate and/or remove 99.999 percent of the plaque forming units of F-specific bacteriophage MS2, or polio virus in the wastewater. A virus that is at least as resistant to disinfection as polio virus may be used for purposes of the demonstration.
- (b) The median concentration of total coliform bacteria measured in the disinfected effluent does not exceed an MPN of 2.2 per 100 milliliters utilizing the bacteriological results of the last seven days for which analyses have been completed and the number of total coliform bacteria does not exceed an MPN of 23 per 100 milliliters in more than one sample in any 30-day period. No sample exceeds an MPN of 240 total coliform bacteria per 100 milliliters.

Dual-Plumbed System

A system that utilizes separate piping systems for recycled water and potable water within a facility and where the recycled water is used for either of the following purposes:

- (a) To serve plumbing outlets (excluding fire suppression systems) within a building or
- (b) Outdoor landscape irrigation at individual residences.

Estimated Chemical Concentration

The estimated chemical concentration that results from the confirmed detection of the substance by the analytical method below the ML value.

Filtered Wastewater

An oxidized wastewater that meets the criteria in subsection (a) or (b):

- (a) Has been coagulated and passed through natural undisturbed soils or a bed of filter media pursuant to the following:
 - (1) At a rate that does not exceed 5 gallons per minute per square foot of surface area in mono, dual or mixed media gravity, upflow or pressure filtration systems, or does not exceed 2 gallons per minute per square foot of surface area in travelling automatic backwash filters; and
 - (2) So that the turbidity of the filtered wastewater does not exceed any of the following:
 - i An average 2 NTU within a 24-hour period;
 - ii 5 NTU more than 5 percent of the time within a 24-hour period; and
 - iii 10 NTU at any time.
- (b) Has been passed through a microfiltration, ultrafiltration, nanofiltration, or reverse osmosis membrane so that the turbidity of the filtered wastewater does not exceed any of the following:

- (1) 0.2 NTU more than 5 percent of the time within a 24-hour period; and
- (2) 0.5 NTU at any time.

F-specific bacteriophage MS-2

A strain of a specific type of virus that infects coliform bacteria that is traceable to the American Type Culture Collection (ATCC 15597B1) and is grown on lawns of *E. Coli* (ATCC 15597).

Grab Sample

An individual sample collected during a period not to exceed 15 minutes. Grab samples shall be collected during normal peak loading conditions for the parameter of interest, which may or may not occur during hydraulic peaks.

Groundwater Replenishment Reuse Project or GRRP

A project involving the planned use of recycled municipal wastewater that is operated for the purpose of replenishing a groundwater basin designated in the Water Quality Control Plan (as defined in Water Code section 13050(j)) for use as a source of municipal and domestic water supply.

Haloacetic Acids, Total

The sum of monochloroacetic acid, dichloroacetic acid, trichloroacetic acid, monobromoacetic acid, and dibromoacetic acid.

Indicator Compound

An individual chemical in a GRRP's municipal wastewater that represents the physical, chemical, and biodegradable characteristics of a specific family of trace organic chemicals; is present in concentrations that provide information relative to the environmental fate and transport of those chemicals; may be used to monitor the efficiency of trace organic compounds removal by treatment processes; and provides an indication of treatment process failure.

Incidental Runoff

Unintended small amounts (volume) of runoff from recycled water use areas, such as unintended, minimal over-spray from sprinklers that escapes the recycled water use area.

Instantaneous Maximum Effluent Limitation

The highest allowable value for any single grab sample or aliquot (i.e., each grab sample or aliquot is independently compared to the instantaneous maximum limitation).

Instantaneous Minimum Effluent Limitation

The lowest allowable value for any single sample or aliquot (i.e., each grab sample or aliquot is independently compared to the instantaneous minimum limitation).

Intrinsic Tracer

A substance or attribute present in the recharge water at levels different from the receiving groundwater such that the substance in the water applied at the GRRP can be

distinctly and sufficiently detected in the groundwater downgradient of the GRRP to determine the underground retention time of the water.

Maximum Contaminant Level (MCL)

The maximum permissible concentration of a contaminant established pursuant to section 116275(c)(1) and (d) of the Health and Safety Code or established by the United States Environmental Protection Agency (USEPA).

Maximum Daily Effluent Limitation (MDEL)

The highest allowable daily discharge of a pollutant over a calendar day (or 24-hour period). For pollutants with limitations expressed in units of mass, the daily discharge is calculated as the total mass of the pollutant discharged over the day. For pollutants with limitations expressed in other units of measurement, the daily discharge is calculated as the arithmetic mean measurement of the pollutant over the day.

Median

The middle measurement in a set of data. The median of a data set is found by first arranging the measurements in order of magnitude (either increasing or decreasing order). If the number of measurements (n) is odd, then the median = $X_{(n+1)/2}$. If n is even, then the median = $(X_{n/2} + X_{(n/2) + 1})/2$ (i.e., the midpoint between the $n/2$ and $n/2+1$).

Method Detection Limit

MDL is the minimum concentration of a substance that can be reported with 99 percent confidence that the measured concentration is distinguishable from method blank results.

Minimum Level (ML)

The concentration at which the entire analytical system must give a recognizable signal and acceptable calibration point. The ML is the concentration in a sample that is equivalent to the concentration of the lowest calibration standard analyzed by a specific analytical procedure, assuming that all the method specified sample weights, volumes, and processing steps have been followed.

Minimum Reporting Level (MRL)

The smallest measured concentration of a substance that can be reliably measured by using a given analytical method. It is the “less-than” value reported when an analyte either is not detected or is detected at a concentration less than the MRL.

Modal Contact Time

The amount of time elapsed between the time that a tracer, such as salt or dye, is injected into the effluent at the entrance to a chamber and the time that the highest concentration of the tracer is observed in the effluent from the chamber.

Nitrogen, Total

The sum of ammonia, nitrite, nitrate, and organic nitrogen-containing compounds, expressed as nitrogen.

Not Detected (ND)

Sample results which are less than the laboratory's MDL.

Notification Level (NL)

The concentration of a contaminant established by the Department pursuant to section 116455 of the Health and Safety Code.

NTU (Nephelometric Turbidity Unit)

A measurement of turbidity as determined by the ratio of the intensity of light scattered by the sample to the intensity of incident light scattered by the sample to the intensity of incident light as measured by method 2130 B. in Standard Methods for the Examination of Water and Wastewater, 20th ed.; Eaton, A.D., Clesceri, L.S., and Greenberg, A.E., Eds; American Public Health Association: Washington, DC, 1995; p.2-8.

Oxidized Wastewater

Wastewater in which the organic matter has been stabilized, is nonputrescible, and contains dissolved oxygen.

Polychlorinated Biphenyls (PCBs)

The sum of chlorinated biphenyls whose analytical characteristics resemble those of Arochlor-1016, Arochlor-1221, Arochlor-1232, Arochlor-1242, Arochlor-1248, Arochlor-1254, and Arochlor-1260.

Recharge Water

Recycled municipal wastewater, or the combination of recycled municipal wastewater and credited diluent water, which is utilized by a GRRP for groundwater replenishment.

Recycled Municipal Wastewater

Recycled water that is the effluent from the treatment of wastewater of municipal origin.

Recycled Municipal Wastewater Contribution or RWC

The fraction equal to the quantity of recycled municipal wastewater applied at the GRRP divided by the sum of the quantity of recycled municipal wastewater and credited diluent water.

Recycled Water

Water which, as a result of treatment of waste, is suitable for a direct beneficial use or a controlled use that would not otherwise occur therefore considered a valuable resource. (Wat. Code, § 13050(n).)

Running Annual Average

The arithmetic mean, calculated quarterly, of the monitoring results from the previous four consecutive quarters. If no sample was collected during a quarter or a result for a

quarter is not available, only available data shall be used in the calculation of the running annual average.

Running Four-Week Average

The arithmetic mean, calculated weekly, of the monitoring results from the previous four consecutive weekly sample results.

Spray Irrigation

The application of recycled water to plants to maintain vegetation or support growth of vegetation by applying it from sprinklers.

Subsurface Application

The application of recharge water to a groundwater basin(s) by a means other than surface application.

Surface Irrigation

Application of recycled water by means other than spraying such that contact between the edible portion of any food crop and recycled water is prevented (i.e., drip or flood irrigation).

Surrogate Parameter

A measurable physical or chemical property that has been demonstrated to provide a direct correlation with the concentration of an indicator compound, can be used to monitor the efficiency of trace organic compounds removal by a treatment process, and/or provides an indication of a treatment process failure.

Total Organic Carbon (TOC)

The concentration of organic carbon present in water.

Trihalomethanes, Total

The sum of Bromodichloromethane, Bromoform, Chloroform, and Dibromochloromethane.

Use Area

An area of recycled water use with defined boundaries. Agricultural use areas may contain one or more facilities (ditch, irrigated fields, pumping stations, etc); use areas may also consist of an aggregate of small lots (e.g., residential/ industrial developments, roadway median irrigation, etc.).

ATTACHMENT B – SWIP PROJECT FLOW DIAGRAM

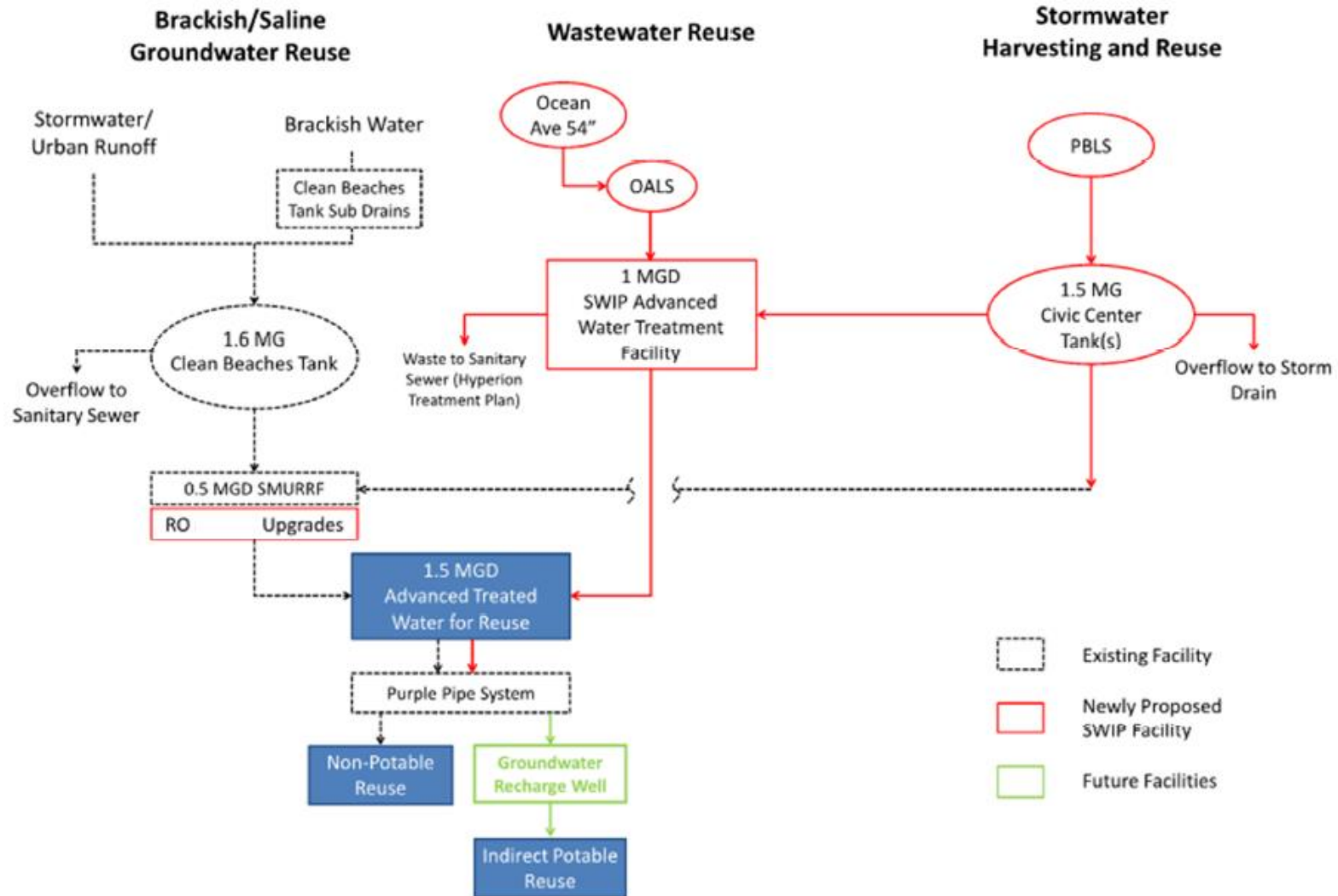

ATTACHMENT C1 – AWTF PROCESS FLOWDIAGRAM

SANTA MONICA SUSTAINABLE WATER INFRASTRUCTURE PROJECT (SWIP)
 AWTF PROCESS FLOW DIAGRAM

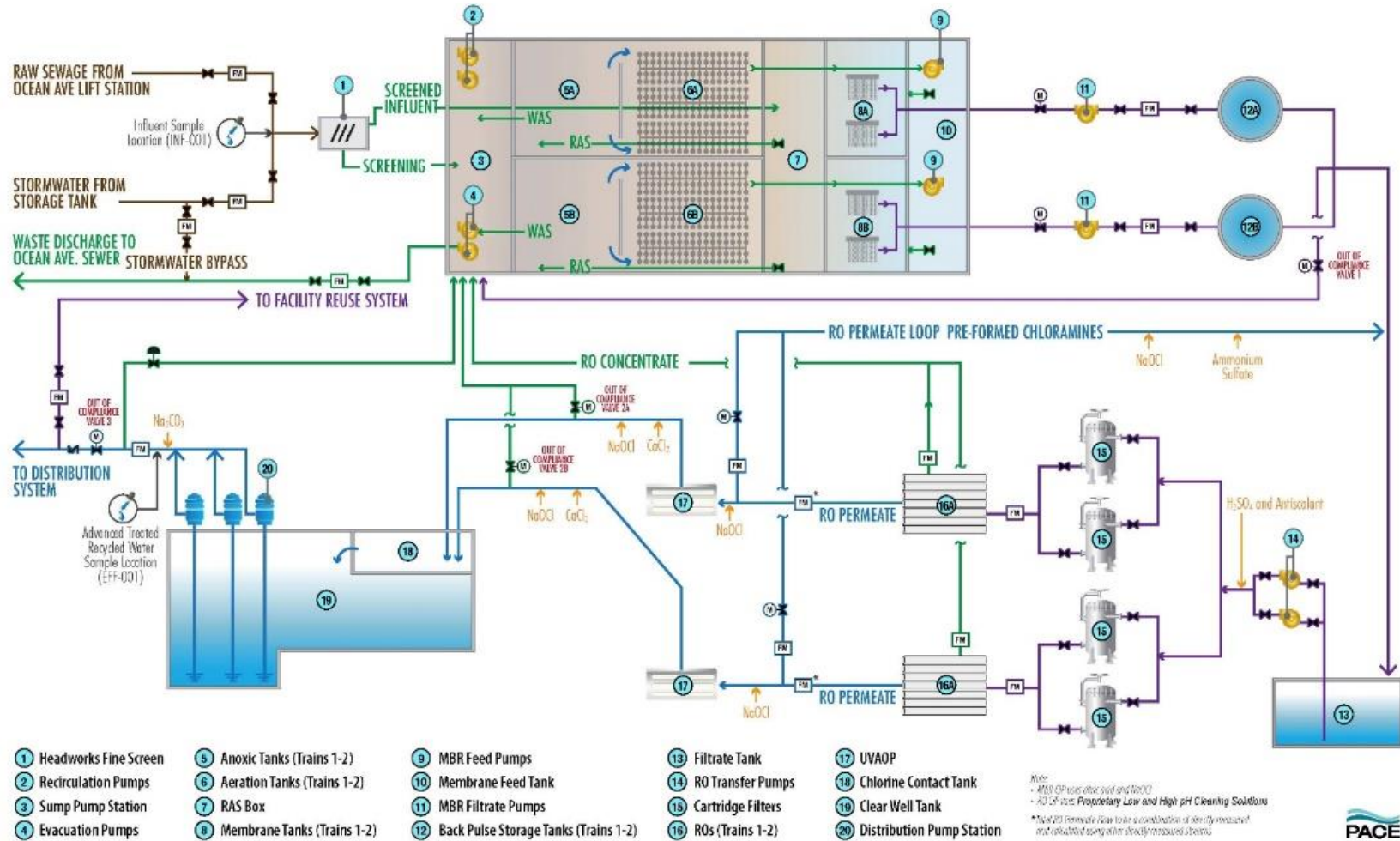

ATTACHMENT C2 – RECYCLED WATER DISTRIBUTION AREA



ATTACHMENT C3 – SANTA MONICA GROUNDWATER SUBBASINS

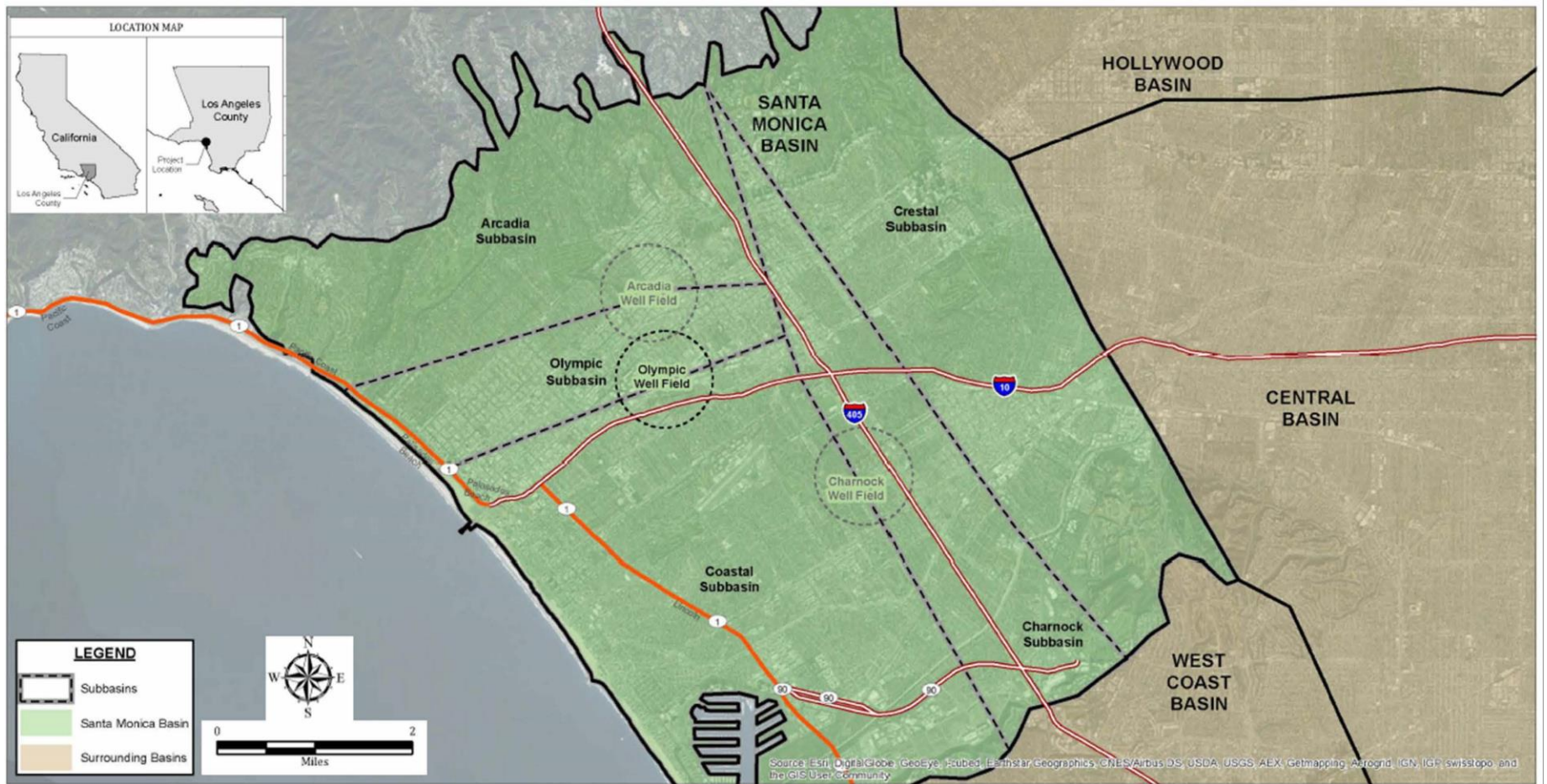

ATTACHMENT D - STANDARD PROVISIONS

STANDARD PROVISIONS APPLICABLE TO WASTE DISCHARGE REQUIREMENTS

1. Duty to Comply

The Permittee shall comply with all conditions of these waste discharge requirements. A responsible party has been designated in the Order for this project and is legally bound to maintain the monitoring program and permit. Violations may result in enforcement actions, including Los Angeles Water Board orders or court orders requiring corrective action or imposing civil monetary liability, or in modification or revocation of these waste discharge requirements by the Los Angeles Water Board (CWC sections 13261, 13263, 13265, 13268, 13300, 13301, 13304, 13340, 13350). Failure to comply with any waste discharge requirement, monitoring and reporting requirement, or other order or prohibition issued, reissued, or amended by the Los Angeles Water Board or State Water Board is a violation of these waste discharge requirements and the Water Code, which can result in the imposition of civil liability. (CWC section 13350, subdivision (a)).

2. General Prohibition

Neither the treatment nor the discharge of waste shall create a pollution, contamination or nuisance, as defined by CWC section 13050. In addition, the discharge of waste classified as hazardous, as defined in 23 CCR 2521(a), is also prohibited.

3. Availability

A copy of these waste discharge requirements shall be maintained at the discharge facility and be available at all times to operating personnel (CWC section 13263).

4. Change in Ownership

The Permittee shall notify any succeeding owner or operator of the existence of this Order by letter, a copy of which shall be forwarded to the Los Angeles Water Board. The Permittee shall notify the Los Angeles Water Board, in writing, at least 60 days in advance of ownership change and provide a date on which the transfer of this Order's responsibility and coverage will go from the current discharger to the new discharger. The notification shall include an agreement between the parties to transfer responsibility for compliance with the Order. The agreement shall include an acknowledgement that the existing discharger is liable for violations up to the transfer date and that the new discharger is liable from the transfer date forward. The succeeding owner or operator shall submit a Report of Waste Discharge that requests an amendment to formally amend the Order to acknowledge the transfer.

5. Change in Discharge

In the event of a material change in the character, location, or volume of a discharge, the Permittee shall file with the Los Angeles Water Board a new Report of Waste Discharge (CWC section 13260, subdivision (c)). A material change includes, but is not limited to, the following:

- 5.1. Addition of a major industrial waste discharge to a discharge of essentially domestic sewage, or the addition of a new process or product by an industrial facility resulting in a change in the character of the waste.
- 5.2. Significant change in disposal method, e.g., change from a land disposal to a direct discharge to water, or change in the method of treatment which would significantly alter the characteristics of the waste.
- 5.3. Significant change in the disposal area, e.g., moving the discharge to another drainage area, to a different water body, or to a disposal area significantly removed from the original area potentially causing different water quality or nuisance problems.
- 5.4. Increase in flow beyond that specified in the waste discharge requirements.
- 5.5. Increase in area or depth to be used for solid waste disposal beyond that specified in the waste discharge requirements (23 CCR § 2210).

6. Revision

These waste discharge requirements are subject to review and revision by the Los Angeles Water Board (CWC section 13263).

7. Notification

Where the Permittee becomes aware that it failed to submit any relevant facts in a Report of Waste Discharge or submitted incorrect information in a Report of Waste Discharge or in any report to the Los Angeles Water Board, it shall promptly submit such facts or information (CWC sections 13260 and 13267).

8. Vested Rights

This Order does not convey any property rights of any sort or any exclusive privileges. The requirements prescribed herein do not authorize the commission of any act causing injury to persons or property, do not protect the Permittee from his liability under Federal, State or local laws, nor do they create a vested right for the Permittee to continue the waste discharge (CWC section 13263 subdivision (g)).

9. Severability

Provisions of these waste discharge requirements are severable. If any provision of these requirements is found invalid, the remainder of these requirements shall not be affected (CWC section 921).

10. Operation and Maintenance

The Permittee shall, at all times, properly operate and maintain all facilities and systems of treatment and control (and related appurtenances) which are installed or used by the Permittee to achieve compliance with conditions of this Order. Proper operation and maintenance includes effective performance, adequate funding, adequate operator staffing and training, and adequate laboratory and process controls including appropriate quality assurance procedures. This provision requires the operation of backup or auxiliary facilities or similar systems only when necessary to achieve compliance with the conditions of this Order (CWC section 13263, subdivision (f)).

11. Hazardous Releases

Except for a discharge which is in compliance with these waste discharge requirements, any person who, without regard to intent or negligence, causes or permits any hazardous substance or sewage to be discharged in or on any waters of the State, or discharged or deposited where it is, or probably will be, discharged in or on any waters of the State, shall, as soon as (a) that person has knowledge of the discharge, (b) notification is possible, and (c) notification can be provided without substantially impeding cleanup or other emergency measures, immediately notify the Office of Emergency Services of the discharge in accordance with the spill reporting provision of the State toxic disaster contingency plan adopted pursuant to Article 3.7 (commencing with section 8574.16) of the Government Code, and immediately notify the State Water Board or the appropriate Los Angeles Water Board of the discharge. This provision does not require reporting of any discharge of less than a reportable quantity as provided for under subdivisions (f) and (g) of CWC section 13271 unless the discharge is in violation of a prohibition in the applicable Water Quality Control Plan (CWC section 13271, subdivision (a)).

12. Oil or Petroleum Releases

Except for a discharge which is in compliance with these waste discharge requirements, any person who without regard to intent or negligence, causes or permits any oil or petroleum product to be discharged in or on any waters of the State, or discharged or deposited where it is, or probably will be, discharged in or on any water of the State, shall, as soon as (a) such person has knowledge of the discharge, (b) notification is possible, and (c) notification can be provided without substantially impeding cleanup or other emergency measures, immediately notify the Office of Emergency Services of the discharge in accordance with the spill reporting provision of the State oil spill contingency plan adopted pursuant to Article 3.5 (commencing with section 8574.1) of the Chapter 7, Division 1, of Title 2 of the Government Code. This provision does not require reporting of any discharge of less than 42 gallons unless the discharge is also required to be reported pursuant to Section 311 of the Clean Water Act or the discharge is in violation of a prohibition in the applicable Water Quality Control Plan (CWC section 13272).

13. Entry and Inspection

The Permittee shall allow the Los Angeles Water Board, or an authorized representative upon the presentation of credentials and other documents as may be required by law, to:

- 13.1. Enter upon the Permittee's processes where a regulated facility or activity is located or conducted, or where records shall be kept under the conditions of this Order;
- 13.2. Have access to and copy at reasonable times, any records that shall be kept under the conditions of this Order;
- 13.3. Inspect at reasonable times any facilities, equipment (including monitoring and control equipment), practices, or operations regulated or required under this Order; and
- 13.4. Sample or monitor at reasonable times, for the purposes of assuring compliance with this Order, or as otherwise authorized by the California Water Code, any substances or parameters at any location (CWC section 13267).
- 13.5. Except for material determined to be confidential in accordance with applicable law, all reports prepared in accordance with the terms of this Order shall be available for public inspection at the Los Angeles Water Board office. Data on waste discharges, water quality, geology, and hydrogeology shall not be considered confidential.

14. Monitoring Program and Devices

The Permittee shall furnish, under penalty of perjury, technical monitoring program reports; such reports shall be submitted in accordance with specifications prepared by the Executive Officer, which specifications are subject to periodic revisions as may be warranted (CWC section 13267).

All monitoring instruments and devices used by the discharger to fulfill the prescribed monitoring program shall be properly maintained and calibrated as necessary to ensure their continued accuracy. All flow measurement devices shall be calibrated at least once per year, or more frequently, to ensure continued accuracy of the devices. Annually, the Permittee shall submit to the Executive Officer a written statement, signed by a registered professional engineer, certifying that all flow measurement devices have been calibrated and will reliably achieve the accuracy required.

The analysis of any material required pursuant to Division 7 of the Water Code shall be performed by a laboratory that has accreditation or certification pursuant to Article 3 (commencing with section 100825) of Chapter 4, Part 1, Division 101 of the Health and Safety Code. However, this requirement does not apply field tests, such as tests of color, odor, turbidity, pH, temperature, dissolved oxygen, conductivity, and disinfectant residual chlorine (CWC, section 1376).

Unless otherwise permitted by the Los Angeles Water Board Executive Officer, all analyses shall be conducted at a laboratory certified for such analyses by the State Water Resources Control Board, Division of Drinking Water. All analyses shall be required to be conducted in accordance with the latest edition of "Guidelines Establishing Test Procedures for Analysis of Pollutants" (40 CFR § 136) promulgated by the USEPA (23 CCR § 2230). The Quality Assurance-Quality Control Program must conform with the USEPA guidelines, "Laboratory Documentation Requirements for Data Validation," January 1990, USEPA Region 9) or procedures approved by the Los Angeles Regional Water Quality Control Board.

All Quality Assurance and Quality Control (QA/QC) analyses must be run on the same dates when samples were actually analyzed. All QA/QC data shall be reported, along with the sample results to which they apply, including the method, equipment, analytical detection and quantification limits, percent recovery, and an explanation for any recovery that falls outside the QC limits, the results of the method and equipment blanks, the results of spiked and surrogate samples, the frequency of quality control analysis, and the name and qualifications of the person(s) performing the analyses. Sample results shall be reported unadjusted for blank results or spike recoveries. In cases where contaminants are detected in QA/QC samples (e.g. field, trip, or lab blanks), the accompanying sample results shall be appropriately flagged.

The Permittee shall make all QA/QC data available for inspection by Los Angeles Water Board staff and submit the QA/QC documentation with its respective monitoring report. Proper chain of custody procedures must be followed, and a copy of that documentation shall be submitted with the monitoring report.

15. Treatment Failure

In an enforcement action, it shall not be a defense for the Permittee that it would have been necessary to halt or to reduce the permitted activity in order to maintain compliance with this Order. Upon reduction, loss, or failure of the treatment facility, the Permittee shall, to the extent necessary to maintain compliance with this Order, control production or all discharges, or both, until the facility is restored, or an alternative method of treatment is provided. This provision applies, for example, when the primary source of power of the treatment facility fails, is reduced, or is lost (CWC section 13263, subdivision (f)).

16. Discharge to Navigable Waters

Any person discharging or proposing to discharge to navigable waters of the United States within the jurisdiction of this state or a person who discharges dredged or fill material or proposes to discharge dredged or fill material into navigable waters of the United States within jurisdiction of this state, shall file a report of waste discharge in compliance with the procedures set forth in CWC section 13260 (CWC section 13376).

17. Endangerment to Health and Environment

The Permittee shall report any noncompliance which may endanger health or the environment. Any such information shall be provided verbally to the Executive Officer within 24 hours from the time the Permittee becomes aware of the circumstances. A written submission shall also be provided within five days of the time the Permittee becomes aware of the circumstances. The written submission shall contain a description and times, and if the noncompliance has not been corrected; the anticipated time it is expected to continue and steps taken or planned to reduce, eliminate, and prevent recurrence of the noncompliance. The Executive Officer, or an authorized representative, may waive the written report on a case-by-case basis if the oral report has been received within 24 hours. The following occurrence(s) shall be reported to the Executive Officer within 24 hours:

- 17.1. Any bypass from any portion of the treatment facility;
- 17.2. Any discharge of treated or untreated wastewater resulting from sewer line breaks, obstruction, surcharge or any other circumstances; and,
- 17.3. Any treatment plant upset which causes the effluent limitation of this order to be exceeded (CWC sections 13263 and 13267).

18. Maintenance of Records

The Permittee shall retain records of all monitoring information including all calibration and maintenance records, all original strip chart recordings for continuous monitoring instrumentation, copies of all reports required by this Order, and records of all data used to complete the application for this Order. Records shall be maintained for a minimum of three years from the date of the sample, measurement, report, or application. This period may be extended during the course of any unresolved litigation regarding this discharge or when requested by the Los Angeles Water Board Executive Officer.

Records of monitoring information shall include:

- 18.1. The date, exact place, and time of sampling or measurements;
- 18.2. The individual(s) who performed the sampling or measurements;
- 18.3. The date(s) analyses were performed;
- 18.4. The individual(s) who performed the analyses;
- 18.5. The analytical techniques or method used; and
- 18.6. The results of such analyses.

19. Signatory Requirement

- 19.1. All application reports or information to be submitted to the Executive Officer shall be signed and certified as follows:
 - 19.1.1. For a corporation – by a principle executive officer or at least the level of vice president.

- 19.1.2. For a partnership or sole proprietorship – by a general partner or the proprietor, respectively.
- 19.1.3. For a municipality, state, federal or other public agency – by either a principal executive officer or ranking elected official.
- 19.2. A duly authorized representative of a person designated in paragraph (a) of this provision may sign documents if:
 - 19.2.1. The authorization is made in writing by a person described in paragraph (a) of this provision.
 - 19.2.2. The authorization specifies either an individual or position having responsibility for the overall operation of the regulated facility or activity.
 - 19.2.3. The written authorization is submitted to the Executive Officer.

Any person signing a document under this section shall make the following certification:

“I certify under penalty of law that I have personally examined and am familiar with the information submitted in this document and all attachments and that, based on my inquiry of those individuals immediately responsible for obtaining the information, I believe that the information is true, accurate, and complete. I am aware that there are significant penalties for submitting false information, including the possibility of fine and imprisonment. [CWC Sections 13263, 13267, and 13268].”

20. Operator Certification

Supervisors and operators of water recycling treatment plants shall possess a certificate of appropriate grade in accordance with 23 CCR § 3680. State Water Boards may accept experience in lieu of qualification training (23 CCR § 3680). In lieu of a properly certified wastewater treatment plant operator, the State Water Board may approve use of a water treatment plant operator of appropriate grade certified by the State Department of Public Health where reclamation is involved (23 CCR § 3670.2).

ATTACHMENT E – MONITORING AND REPORTING PROGRAM (MRP) CI-10569

CONTENTS

1.	GENERAL MONITORING AND REPORTING REQUIREMENTS	2
2.	DDW MONITORING REQUIRMENTS	5
3.	MONITORING REQUIREMENTS	5
4.	USE AREA MONITORING	11
5.	REPORTING REQUIREMENTS	12
6.	REPORT SUBMITTAL DATES	17
7.	CERTIFICATION STATEMENT	18
8.	OPERATIONS AND MAINTENANCE MANUAL	18
9.	CLIMATE CHANGE VULNERABILITY ASSESSMENT AND MANAGEMENT PLAN.....	18

TABLES

TABLE E1.	MONITORING LOCATIONS.....	5
TABLE E2.	INFLUENT MONITORING.....	6
TABLE E3.	RECYCLED WATER MONITORING	7
TABLE E4.	PRIORITY POLLUTANTS	8
TABLE E5.	USE AREA MONITORING	11
TABLE E6.	DUAL-PLUMBED SYSTEMS TESTING/MONITORING.....	16
TABLE E7.	MONITORING PERIODS AND REPORTING SCHEDULE	17

ATTACHMENT E - MONITORING AND REPORTING PROGRAM (MRP) CI-10569

This Monitoring and Reporting Program is issued by the Regional Water Quality Control Board, Los Angeles Region (Los Angeles Water Board) pursuant to California Water Code (CWC) section 13267(b)(1), which authorizes the Los Angeles Water Board to require the submittal of technical and monitoring reports. The reports required by this MRP are necessary to ensure compliance with Waste Discharge Requirements (WDRs) and Water Reclamation Requirements (WRRs) Order No. R4-2021-0044 for the Santa Monica Advanced Water Treatment Facility (AWTF). The City of Santa Monica (City or Permittee) owns and operates the AWTF and the recycled water distribution system, respectively, and is therefore, responsible for compliance with this Order. The City shall implement this MRP on the effective date of this Order. Failure to comply with this MRP could result in the imposition of monetary civil liability pursuant to Division 7 of the California Water Code and other applicable laws.

1. GENERAL MONITORING AND REPORTING REQUIREMENTS

- 1.1. The Permittee shall monitor the following according to the manner and frequency specified in this MRP:
 - 1.1.1. Influent to the Advanced Water Treatment Facility (AWTF).
 - 1.1.2. Advanced treated recycled water.
- 1.2. Monitoring reports shall include, but are not limited to, the following:
 - Analytical results.
 - Location of each sampling station where representative samples are obtained.
 - Analytical test methods used and the corresponding minimum reporting levels (MRLs).
 - Name(s) of the laboratory that conducted the analyses.
 - Copy of laboratory certifications by the State Water Resources Control Board, Division of Drinking Water's (DDW) Environmental Laboratory Accreditation Program (ELAP).
 - A summary of quality assurance and control (QA/QC) measures, including documentation of chain of custody.
 - Applicable Maximum Contaminant Levels (MCLs), Notification Levels (NLs), response levels, or DDW conditions or advanced treated recycled water discharge limits.
 - A summary of noncompliance during the monitoring period.
- 1.3. The City shall have written sampling protocols in place. The sampling protocols shall also include the procedures for handling, storing, testing, and disposing of purge and decontamination waters generated from the sampling events.
- 1.4. The City shall notify this Los Angeles Water Board and DDW by telephone (Steven Webb at (213) 576-6793 and Saeed Hafeznezami at (818) 551-2972)

or electronic means (losangeles@waterboards.ca.gov and DDWRegion4@waterboards.ca.gov) within 24 hours of knowledge of any violations of this Order that may endanger human health or the environment. Written confirmation shall be submitted within 5 working days from the date of notification. The report shall include, but shall not be limited to the following information:

- The nature and extent of the violation;
 - The date and time when the violation started; when compliance was achieved; and, when distribution of recycled water was suspended and restored, as applicable;
 - The duration of the violation;
 - The cause(s) of the violation;
 - Any corrective and/or remedial actions that have been taken and/or will be taken with a time schedule for implementation to prevent future violations; and,
 - Any impact of the violation.
- 1.5. Samples shall be analyzed using analytical methods described in Section 141 of Title 40 of the Code of Federal Regulations (40 CFR § 141); or where no methods are specified for a given pollutant, by methods approved by DDW, the Los Angeles Water Board and/or the State Water Board, the City shall select the analytical methods that provide Minimum Reporting Levels (MRLs) lower than the limits prescribed in this Order or as low as possible that will provide reliable data.
- 1.6. Analyses for chemicals other than those with primary MCLs and secondary MCLs, the City shall select methods based on the following approach:
- 1.6.1. Use the drinking water methods or wastewater methods sufficient to evaluate all water quality objectives and protect all beneficial uses.
 - 1.6.2. Use DDW-recommended methods for unregulated chemicals, if available.
 - 1.6.3. If there is no DDW-recommended drinking water method for a chemical, and more than a single United States Environmental Protection Agency (USEPA)-approved method is available, use the most sensitive of the USEPA-approved method.
 - 1.6.4. If there is no USEPA-approved method for a chemical, and more than one method is available from the scientific literature and commercial laboratory, after consultation with DDW, use the most sensitive method.
 - 1.6.5. If no approved method is available for a specific chemical, the City's laboratory may develop or use its own methods and should provide the analytical methods to DDW for review. Those methods may be used until DDW-recommended or USEPA-approved methods are available.

- 1.6.6. If the only method available for a chemical is for wastewater analysis (e.g. a chemical listed as a priority pollutant only), that chemical will be sampled and analyzed using wastewater methods specified in 40 CFR § 136. This approach will be used until a DDW-recommended or EPA-approved drinking water method is available.
- 1.6.7. For CECs subject to the Recycled Water Policy, monitoring of advanced treated recycled water and tertiary treated recycled water prior to RO/AOP shall use analytical methods selected to achieve the Reporting Limits included in the Recycled Water Policy. Any modifications to the published or certified methods shall be reviewed by DDW and subsequently submitted to the Los Angeles Water Board in an updated quality assurance plan.
- 1.7. The Permittee shall instruct its laboratories to establish calibration standards so that the MRLs (or equivalent if there is a different treatment of samples relative to calibration standards) are the lowest calibration standard. At no time shall the analytical data be derived from extrapolation beyond the lowest point of the calibration curve.
- 1.8. Pursuant to 22 CCR § 60320.204, analyses for contaminants having primary or secondary MCLs shall be performed by laboratories approved to perform such analyses by DDW using DDW-approved drinking water methods.
- 1.9. For regulated constituents, the laboratory conducting the analyses shall be certified by the Environmental Laboratory Accreditation Program (ELAP) or approved by DDW or the Los Angeles Water Board.
- 1.10. Upon request by the Permittee, the Los Angeles Water Board, in consultation with DDW and the State Water Board Quality Assurance Program, may establish MRLs, in any of the following situations:
 - 1.9.1. When the pollutant has no established method under 40 CFR § 141;
 - 1.9.2. When the method under 40 CFR § 141 for the pollutant has an MRL higher than the limit specified in this Order; or
 - 1.9.3. When the Permittee agrees to use a test method that is more sensitive than those specified in 40 CFR § 141.
- 1.11. Samples shall be analyzed within allowable holding time limits as specified in 40 CFR § 141. All QA/QC analyses shall be conducted on the same dates the samples are analyzed. The City shall retain the QA/QC documentation in its files for three years and make available for inspection and/or submit them when requested by the Los Angeles Water Board or DDW. Proper chain of custody procedures shall be followed, and a copy of this documentation shall be submitted with the quarterly report.
- 1.12. Each monitoring report shall include a separate section titled "Summary of Non-compliance" which discusses the compliance record and corrective actions taken or planned that may be needed to bring the discharge into full compliance with waste discharge requirements. This section shall clearly list

all non-compliance with discharge requirements as well as all excursions of the final effluent limitations.

- 1.13. For bacterial analyses, sample dilutions shall be performed so the expected range of values is bracketed (for example, with multiple tube fermentation method or membrane filtration method, 2 to 16,000 per 100 mL for total, fecal coliform, and *E. coli*, at a minimum, and 1 to 1000 per 100 ml for *Enterococcus*). The detection methods used for each analysis shall be reported with the results of the analyses.
- 1.14. Quarterly monitoring shall be performed during the months of February, May, August, and November; semiannual monitoring shall be performed during the months of February and August; and annual monitoring shall be performed during the third quarter (July thru September) of each calendar year. Should there be instances when monitoring could not be conducted during the specified months, the City shall conduct the monitoring as soon as possible and state in the monitoring report the reason monitoring could not be conducted during the specified month. Results of quarterly, semiannual and annual analyses shall be reported in the quarterly monitoring report following the analysis.

2. DDW MONITORING REQUIRMENTS

The City shall comply with all monitoring requirements specified in section 9 of the Order, in accordance with the DDW conditional acceptance letter dated August 19, 2020.

3. MONITORING REQUIREMENTS

3.1. MONITORING LOCATIONS

The City shall establish the following monitoring locations to demonstrate compliance with the recycled water discharge limitations and other requirements in this Order. Should the need for a change in the sampling station(s) arise in the future, the City shall seek approval of the proposed station by the Executive Officer prior to use.

TABLE E1. MONITORING LOCATIONS

Monitoring Location Name	Description
INF-001	The influent monitoring location shall be located immediately before the headworks to the AWTF and after the municipal wastewater mixes with stormwater and dry-weather runoff provided to the AWTF, where a representative sample of the influent can be obtained.
EFF-001	The effluent monitoring location shall be located downstream of any in-plant return flows, the final disinfection process, and after stabilization with sodium carbonate addition, where representative samples of the effluent can be obtained.

3.2. INFLUENT MONITORING

3.2.1. Influent monitoring is required to determine compliance with water quality conditions and standards and to assess AWTF performance.

3.2.2. The Permittee shall monitor the pollutants in Table E2 at the influent monitoring location (INF-001) described in Table E1.

The following shall constitute the influent monitoring program:

TABLE E2. INFLUENT MONITORING

Constituent	Units	Type of Sample	Minimum Frequency of Analysis	Notes
Total Sewer Flow	MGD	Recorder	Continuous	Note a
Total Stormwater/ Dry-Weather Runoff Flow	MGD	Recorder	Continuous	Note a
Total Volume	Million Gallons	Calculated	Monthly	---
Biochemical Oxygen Demand (BOD ₅ 20°C)	mg/L	Grab	Weekly	---
Total Suspended Solids (TSS)	mg/L	Grab	Weekly	---
pH	pH Units	Grab	Weekly	---
Total nitrogen	mg/L	Grab	Monthly	---
Nitrate	mg/L	Grab	Monthly	---
Nitrite	mg/L	Grab	Monthly	---
Total dissolved solids (TDS)	mg/L	Grab	Monthly	---

Footnotes for Table E2

a. For those pollutants with a continuous minimum monitoring frequency, the monthly minimum and maximum, and daily average values shall be reported.

End of Footnotes for Table E2

3.3. RECYCLED WATER MONITORING

3.3.1. Recycled water monitoring is required to determine compliance with the permit conditions: (1) identify operational problems and aid in improving facility performance, and (2) provide information on wastewater characteristics and flows for use in interpreting water quality and biological data.

3.3.2. The City shall monitor the advanced treated recycled water used for non-potable use at monitoring location EFF-001. The monitoring location is described in Table E1. The parameters to be monitored and monitoring frequencies are listed in Tables E3 and E4.

The following shall constitute the recycled water monitoring program:

TABLE E3. RECYCLED WATER MONITORING

Constituent	Units	Type of Sample	Minimum Frequency of Analysis	Notes
Total flow recycled water produced	MGD Million Gallons	Recorder Calculated	Continuous Monthly	Note a
Total volume recycled water produced	MGD Million Gallons	Recorder Calculated	Continuous Monthly	Note a
Total volume recycled water delivered to each end user	MGD Million Gallons	Recorder Calculated	Continuous Monthly	Note a
pH	pH units	Recorder	Continuous	Note a
Turbidity (after MF and prior to RO)	NTU	Grab	Weekly	---
Total Coliform	MPN/100 mL	Grab	Daily	Note b
Total Chlorine Residual	mg/L	Recorder	Continuous	Note a
Oil & Grease	mg/L	Grab	Quarterly	---
Settleable Solids	mL/L	Grab	Weekly	---
Total Suspended Solids (TSS)	mg/L	24-hour composite	Weekly	---
Biochemical Oxygen Demand (BOD ₅ 20°C)	mg/L	24-hour composite	Weekly	---
Total Organic Carbon	mg/L	24-hour composite or grab	Weekly	Note c
Conductivity	µS	Recorder	Continuous	Note a
Total Dissolved Solids (TDS)	mg/L	24-hour composite	Monthly	---
Sulfate	mg/L	24-hour composite	Monthly	---
Chloride	mg/L	24-hour composite	Monthly	---
Boron	mg/L	24-hour composite	Monthly	---
Total Nitrogen	mg/L	24-hour composite	Monthly	---
Nitrate-N + nitrite-N	mg/L	24-hour composite	Monthly	---
Nitrate-N	mg/L	24-hour composite	Monthly	---
Nitrite-N	mg/L	24-hour composite	Monthly	---
Priority Pollutants (Table E4)	varies	varies	semiannually	---

Footnotes for Table E3

- a. For those pollutants with a continuous minimum monitoring frequency, the monthly minimum and maximum, and daily average values shall be reported.
- b. For those pollutants with a daily minimum monitoring frequency, samples shall be collected seven days per week unless otherwise specified.
- c. Monitoring results for total organic carbon (TOC) shall be reported as a single result and as a 20-week running average of all TOC results and the average of the last four TOC results. The daily average and maximum TOC reading and the percent of time TOC is greater than 0.5 mg/L shall be reported.

End of Footnotes for Table E3

TABLE E4. PRIORITY POLLUTANTS

Constituent	Units	Type of Sample	Minimum Frequency of Analysis
Acenaphthene	µg/L	24-hour composite or grab	Semiannually
Acrolein	µg/L	24-hour composite or grab	Semiannually
Acrylonitrile	µg/L	grab	Semiannually
Benzene	mg/L	grab	Semiannually
Benzidine	µg/L	24-hour composite or grab	Semiannually
Carbon Tetrachloride	mg/L	grab	Semiannually
Chlorobenzene	µg/L	grab	Semiannually
1,2,4-trichlorobenzene	mg/L	grab	Semiannually
Hexachlorobenzene	mg/L	24-hour composite or grab	Semiannually
1,2-dichloroethane	mg/L	grab	Semiannually
1,1,1-trichloroethane	mg/L	grab	Semiannually
Hexachloroethane	µg/L	grab	Semiannually
1,1-dichloroethane	mg/L	grab	Semiannually
1,1,2-trichloroethane	mg/L	grab	Semiannually
1,1,2,2-tetrachloroethane	mg/L	grab	Semiannually
Chloroethane	µg/L	grab	Semiannually
Bis(2-chloroethyl) ether	µg/L	24-hour composite or grab	Semiannually
2-chloroethyl vinyl ether	µg/L	grab	Semiannually
2-chloronaphthalene	µg/L	24-hour composite or grab	Semiannually
2,4,6-trichlorophenol	µg/L	24-hour composite or grab	Semiannually
Parachlorometa cresol	µg/L	24-hour composite or grab	Semiannually
Chloroform	mg/L	Grab	Semiannually
2-chlorophenol	µg/L	24-hour composite or grab	Semiannually
1,2-dichlorobenzene	mg/L	Grab	Semiannually
1,3-dichlorobenzene	µg/L	Grab	Semiannually
1,4-dichlorobenzene	mg/L	Grab	Semiannually
3,3'-dichlorobenzidine	µg/L	24-hour composite or grab	Semiannually
1,1-dichloroethylene	mg/L	Grab	Semiannually
1,2-trans-dichloroethylene	mg/L	Grab	Semiannually
2,4-dichlorophenol	µg/L	24-hour composite or grab	Semiannually
1,2-dichloropropane	mg/L	Grab	Semiannually
1,3-dichloropropylene	mg/L	Grab	Semiannually
2,4-dimethylphenol	µg/L	24-hour composite or grab	Semiannually
2,4-dinitrotoluene	µg/L	grab	Semiannually
2,6-dinitrotoluene	µg/L	grab	Semiannually
1,2-diphenylhydrazine	µg/L	24-hour composite or grab	Semiannually
Ethylbenzene	mg/L	grab	Semiannually
Fluoranthene	µg/L	grab	Semiannually
4-chlorophenyl phenyl ether	µg/L	24-hour composite or grab	Semiannually
4-bromophenyl phenyl ether	µg/L	24-hour composite or grab	Semiannually

Constituent	Units	Type of Sample	Minimum Frequency of Analysis
Bis(2-chloroisopropyl) ether	µg/L	24-hour composite or grab	Semiannually
Bis(2-chlorethoxy) methane	µg/L	24-hour composite or grab	Semiannually
Methylene chloride	mg/L	Grab	Semiannually
Methyl chloride (chloromethane)	µg/L	Grab	Semiannually
Methyl bromide (bromomethane)	µg/L	Grab	Semiannually
Bromoform	mg/L	Grab	Semiannually
Dichlorobromomethane	mg/L	Grab	Semiannually
Chlorodibromomethane	mg/L	Grab	Semiannually
Hexachlorobutadiene	µg/L	Grab	Semiannually
Hexachlorocyclopentadiene	mg/L	24-hour composite or grab	Semiannually
Isophorone	µg/L	Grab	Semiannually
Naphthalene	mg/L	Grab	Semiannually
Nitrobenzene	µg/L	24-hour composite or grab	Semiannually
2-nitrophenol	µg/L	24-hour composite or grab	Semiannually
4-nitrophenol	µg/L	24-hour composite or grab	Semiannually
2,4-dinitrophenol	µg/L	24-hour composite or grab	Semiannually
4,6-dinitro-o-cresol	µg/L	24-hour composite or grab	Semiannually
N-nitrosodimethylamine	mg/L	Grab	Semiannually
N-nitrosodiphenylamine	mg/L	24-hour composite or grab	Semiannually
N-nitrosodi-n-propylamine	mg/L	24-hour composite or grab	Semiannually
Pentachlorophenol	mg/L	24-hour composite or grab	Semiannually
Phenol	µg/L	24-hour composite or grab	Semiannually
Bis(2-ethylhexyl) phthalate	µg/L	Grab	Semiannually
Butyl benzyl phthalate	µg/L	Grab	Semiannually
Di-n-butyl phthalate	µg/L	Grab	Semiannually
Di-n-octyl phthalate	µg/L	Grab	Semiannually
Diethyl phthalate	µg/L	Grab	Semiannually
Dimethyl phthalate	µg/L	Grab	Semiannually
Benzo(a) anthracene	µg/L	Grab	Semiannually
Benzo(a) pyrene	mg/L	24-hour composite or grab	Semiannually
Benzo(b) fluoranthene	µg/L	Grab	Semiannually
Benzo(k) fluoranthene	µg/L	Grab	Semiannually
Chrysene	µg/L	Grab	Semiannually
Acenaphthylene	µg/L	Grab	Semiannually
Anthracene	µg/L	Grab	Semiannually
Benzo(ghi) perylene	µg/L	Grab	Semiannually
Fluorene	µg/L	Grab	Semiannually
Phenanthrene	µg/L	Grab	Semiannually
Dibenzo(a,h)anthracene	µg/L	Grab	Semiannually

Constituent	Units	Type of Sample	Minimum Frequency of Analysis
Indeno(1,2,3-c,d) pyrene	µg/L	Grab	Semiannually
Pyrene	µg/L	Grab	Semiannually
Tetrachloroethylene	mg/L	Grab	Semiannually
Toluene	mg/L	Grab	Semiannually
Trichloroethylene	mg/L	Grab	Semiannually
Vinyl chloride	mg/L	Grab	Semiannually
Aldrin	µg/L	Grab	Semiannually
Dieldrin	µg/L	Grab	Semiannually
Chlordane	mg/L	24-hour composite or grab	Semiannually
4,4'-DDT	µg/L	24-hour composite or grab	Semiannually
4,4'-DDE	µg/L	24-hour composite or grab	Semiannually
4,4'-DDD	µg/L	24-hour composite or grab	Semiannually
Alpha-endosulfan	µg/L	Grab	Semiannually
Beta-endosulfan	µg/L	Grab	Semiannually
Endosulfan sulfate	µg/L	Grab	Semiannually
Endrin	mg/L	24-hour composite or grab	Semiannually
Endrin aldehyde	µg/L	Grab	Semiannually
Heptachlor	mg/L	24-hour composite or grab	Semiannually
Heptachlor epoxide	mg/L	24-hour composite or grab	Semiannually
Alpha-BHC	µg/L	grab	Semiannually
Beta-BHC	µg/L	grab	Semiannually
Gamma-BHC	mg/L	24-hour composite or grab	Semiannually
Delta-BHC	µg/L	grab	Semiannually
PCB-1242	mg/L	24-hour composite or grab	Semiannually
PCB-1254	mg/L	24-hour composite or grab	Semiannually
PCB-1221	mg/L	24-hour composite or grab	Semiannually
PCB-1232	mg/L	24-hour composite or grab	Semiannually
PCB-1248	mg/L	24-hour composite or grab	Semiannually
PCB-1260	mg/L	24-hour composite or grab	Semiannually
PCB-1016	mg/L	24-hour composite or grab	Semiannually
Toxaphene	mg/L	24-hour composite or grab	Semiannually
Antimony	mg/L	24-hour composite or grab	Semiannually
Arsenic	mg/L	24-hour composite or grab	Semiannually
Asbestos	Million fibers per liter (MFL)	24-hour composite or grab	Semiannually
Beryllium	mg/L	24-hour composite or grab	Semiannually
Cadmium	mg/L	24-hour composite or grab	Semiannually
Chromium	mg/L	24-hour composite or grab	Semiannually
Copper	mg/L	24-hour composite or grab	Semiannually
Cyanide	mg/L	Grab	Semiannually
Lead	mg/L	24-hour composite or grab	Semiannually
Mercury	mg/L	24-hour composite or grab	Semiannually
Nickel	mg/L	24-hour composite or grab	Semiannually
Selenium	mg/L	24-hour composite or grab	Semiannually

Constituent	Units	Type of Sample	Minimum Frequency of Analysis
Silver	mg/L	24-hour composite or grab	Semiannually
Thallium	mg/L	24-hour composite or grab	Semiannually
Zinc	mg/L	24-hour composite or grab	Semiannually
2,3,7,8-TCDD	mg/L	24-hour composite or grab	Semiannually

3.4. GROUNDWATER MONITORING

This Order permits the use of recycled water for nonpotable uses, which meet the site-specific conditions for exemption from groundwater monitoring in the Recycled Water Policy, and therefore does not require groundwater monitoring. The City plans to use recycled water for indirect potable reuse in the future and will need a groundwater monitoring plan at that time. The City shall submit a Report of Waste Discharge to the Los Angeles Water Board once DDW approves a Title 22 Engineering Report for the indirect potable reuse project.

4. USE AREA MONITORING

The City is responsible for ensuring use area data is collected and submitted in the annual report. The following shall be recorded for each user with additional reporting for use areas as appropriate. The frequency of use area inspections shall be based on the complexity and risk of each use area. Use areas may be aggregated to combine acreage for calculation or observation purposes. Use area monitoring shall include:

TABLE E5. USE AREA MONITORING

Parameter	Units	Sample Type	Sampling Frequency	Reporting Frequency
Recycled Water User	---	---	---	Annually
Average Monthly Recycled Water Flow	Gallons per day (gpd)	Meter	Monthly	Annually
Acreage Applied	Acres	Calculated	---	Annually
Application Rate	Inches/acre/year	Calculated	---	Annually
Soil Saturation and Ponding	---	Observation	Quarterly	Annually
Nuisance Odors/Vectors	---	Observation	Quarterly	Annually
Discharge Off-Site	---	Observation	Quarterly	Annually
Notification Signs (Note a)	---	Observation	Quarterly	Annually

Footnotes for Table E5

a. Notification signs shall be consistent with the requirements of 22 CCR § 60310(g).

End of Footnotes for Table E5

5. REPORTING REQUIREMENTS

The City shall submit the required reports, outlined in this section, to the State Water Resources Control Board's (State Water Board) GeoTracker database by the specified dates.

- 5.1. For the purpose of reporting compliance with numerical limitations, analytical data shall be reported using the following reporting protocols:
 - 5.1.1. Sample results greater than or equal to the MRL must be reported "as measured" by the laboratory (i.e., the measured chemical concentration in the sample).
 - 5.1.2. Sample results less than the MRL, but greater than or equal to the laboratory's Minimum Detection Limit (MDL), shall be reported as "Detected, but Not Quantified", "DNQ." The laboratory shall write the estimated chemical concentration of the sample next to "DNQ."
 - 5.1.3. Sample results less than the laboratory's MDL shall be reported as "Not-Detected", or ND.
 - 5.1.4. If the City samples and performs analyses (other than for process/operational control, startup, research, or equipment testing) on any sample more frequently than required in this MRP using approved analytical methods, the results of those analyses shall be included in the report. These results shall be reflected in the calculation of the average used in demonstrating compliance with average effluent, receiving water, etc., limitations.
 - 5.1.5. The Los Angeles Water Board or DDW may request supporting documentation, such as daily logs of operations.
 - 5.1.6. All reports shall reference the Compliance File No. CI-10569 and shall be uploaded to the State Water Board's GeoTracker database (GeoTracker) under Global ID WDR100000408. Compliance monitoring reports shall be submitted separately from other technical reports.
 - 5.1.7. All submittals shall comply with the Electronic Submittal of Information (ESI) requirements by submitting all reports required under the Order, including groundwater monitoring data, discharge location data, and searchable Portable Document Format. If any file exceeds 10 megabytes then the report shall be uploaded in multiple parts. Upon request, the data shall be provided in excel format.
 - 5.1.8. The Permittee shall submit to the Los Angeles Water Board, together with the first monitoring report required by this Order, a list of all chemicals and proprietary additives which could affect the quality of the recycled water, including quantities of each. Any subsequent changes in types and/or quantities shall be reported promptly. An annual summary of the quantities of all chemicals, listed by both trade and chemical names, which are used in the treatment process shall be included in the annual report.

5.2. Monthly Monitoring Reports

Monthly monitoring reports shall be submitted to the Los Angeles Water Board and DDW by the 10th day of the month following the month of sampling and shall include:

- 5.2.1. The results of Membrane Integrity Monitoring and calculated log reduction values (LRVs).
- 5.2.2. The daily average and maximum conductivity readings for the RO effluent, the percent of time the conductivity is greater than 350 micro-Siemens, and the average reduction in electrical conductivity achieved.
- 5.2.3. Continuous turbidity analytical results for the month for the AWTF advanced-treated recycled water (located after MF and before RO) including the daily average, daily maximum, and percent of time turbidity exceeds 0.2 NTU. The City shall also report if the MF effluent turbidity exceeded 0.5 NTU at any time.
- 5.2.4. Summary of the operational parameters and surrogates reviewed and accepted by DDW (ex. NDMA log reduction, Ultraviolet Intensity (UVI), Ultraviolet Transmittance (UVT), power, flow rate (Q), calculated UVI/Q, calculated chlorine dose), and any reactor failures.
- 5.2.5. Based on the daily log reduction calculation, report a “Yes” or “No” for each day to indicate if the necessary pathogenic microorganism log reductions (12-logs virus, 10-logs *Giardia* and *Cryptosporidium* oocyst) have been achieved. The daily minimum model predicated 1,4-dioxane and NDMA log reduction shall also be reported. An overall log reduction calculated value must be provided daily unless the AWTF is offline for a 24-hour period.
- 5.2.6. Daily coliform analytical results for the AWTF advanced-treated recycled water.
- 5.2.7. Summary of the monthly operational parameters for UV and chlorine dose.
- 5.2.8. TOC results for the RO influent and effluent including the average and maximum, and the percent of time TOC is greater than 0.5 mg/L.
- 5.2.9. Records of operational problems, plant and equipment breakdowns, and diversion of emergency storage or disposal, and all corrective or preventative actions taken.

5.3. Quarterly Monitoring Reports

- 5.3.1. Quarterly monitoring reports shall be submitted to the Los Angeles Water Board by the 15th day of the third month following the end of each quarterly monitoring period.
- 5.3.2. The quarterly reports shall include, at a minimum, the following information:

- A one-page summary of operational concerns that address changes in reporting conditions including influent and AWTF recycled water since the last report.
- Summary of monthly operational parameters for calculated 1,4-dioxane and NDMA log reduction along with flowrate, UVT, pH and any reactor failure(s).
- Volume of the influent wastewater, stormwater, dry-weather runoff, and advanced-treated recycled water used for nonpotable uses. If no advanced treated recycled water was used during the quarter, the report shall so state.
- A table listing the users serviced during the quarter, the amount of recycled water delivered to each user (reported in both gallons and in acre-feet), and the use of the recycled water.
- The date and time of sampling and analyses.
- All analytical results of advanced-treated recycled water samples collected during the monitoring period.
- The analytical method used, the method detection limit (MDL), and the RDL for each constituent analyzed.
- The applicable MCL, condition, or permit limitation.
- The name(s) of the laboratory that conducted the analyses and a copy of laboratory certifications from DDW's Environmental Laboratory Accreditation Program (ELAP).
- Records of any operational problems, plant upset(s), equipment breakdowns or malfunctions, and any diversion(s) of off-specification recycled water and the location(s) of final disposal.
- Discussion of compliance, noncompliance, or violation of requirements.
- Summary of operational concerns describing changes in reporting conditions, including influent, AWTF advanced treated recycled water, and any groundwater monitoring results, since the last report.
- All corrective or preventive action(s) taken or planned with a schedule of implementation, if any.

5.4. Annual Summary Reports

- 5.4.1. Annual monitoring reports shall include a minimum of the following:
- a. Tabular and graphical summaries of the monitoring data obtained during the previous calendar year.
 - b. A table listing the users and use areas serviced during the year, the amount of recycled water delivered to each user (reported in both gallons and in acre-feet), and the use of the recycled water. Newly

permitted recycled water users shall be identified. When applicable, a supplement to the Title 22 Engineering Report and the State Water Board approval letter supporting those additions shall be included.

- c. A summary of compliance status with the applicable monitoring requirements during the previous calendar year.
- d. For any non-compliance during the previous calendar year, a description of:
 - The date, duration, and nature of the violation.
 - A summary of any corrective actions and/or suspensions of subsurface application of recycled municipal wastewater resulting from a violation.
 - If uncorrected, a schedule for and summary of all remedial actions.
- e. A description of any changes and anticipated changes, including any impacts in operation of any unit processes or facilities shall be provided.
- f. A summary of the measures taken to comply with wastewater source control program and the effectiveness of the implementation of the measures.
- g. A list of the analytical methods used for each test and associated laboratory quality assurance/quality control procedures shall be included. The report shall identify the laboratories used by the City to monitor compliance with this Order, their status of certification, and provide a summary of their proficiency test.
- h. A list of current operating personnel, their responsibilities, and their corresponding grade and date of certification.
- i. The date of the facility's Operation and Maintenance (O&M) Management Plan, the date the plan was last reviewed, and whether the plan is complete and valid for the current facilities.
- j. A summary table of all inspections and enforcement activities initiated by the City. Include a discussion of compliance and corrective actions taken, as well as any planned or proposed actions needed to bring the discharge into compliance. Copies of documentation of any enforcement actions taken by the City shall be provided.
- k. An evaluation of the performance of the recycled water system for the AWTF including a discussion of capacity issues, system problems, and a forecast of the flows anticipated for the following year.

5.4.2 Annual Volumetric Reporting

All volumetric data measured monthly shall be reported on an annual basis as acre-feet (af) to the GeoTracker database under the “Other Tools: submit Annual Volumetric Water Data.” Monthly volume of influent, recycled water produced, and distributed for beneficial use in compliance with Title 22 in each of the use categories below:

- Agricultural irrigation: pasture or crop irrigation
- Landscape irrigation: irrigation of parks, greenbelts, playgrounds, school yards, athletic fields, cemeteries, residential landscaping, freeway landscaping, highway landscaping, and street landscaping.
- Golf course irrigation: irrigation of golf courses, including water used to maintain aesthetic impoundments within golf courses.
- Commercial application: commercial facilities, business use (such as laundries or office buildings), car washes, retail nurseries, and appurtenant landscaping that is not separately metered.
- Industrial Application: manufacturing facilities, cooling towers, process water, and appurtenant landscaping that is not separately metered.
- Geothermal energy production: augmentation of geothermal fields.
- Other non-potable uses including but not limited to dust control, flushing sewers, fire protection, fill stations, snow making, and dual-plumbed systems.
- Groundwater recharge: surface or subsurface application, except for seawater intrusion barrier use.

5.6. Dual-Plumbed Recycled Water Systems Testing/Monitoring

For dual-plumbed systems, DDW and/or its delegated local agency shall be consulted for additional reporting, design, and operation requirements. The potential for cross-connections and backflow prevention devices shall be monitored as listed below, or more frequently if specified by DDW.

TABLE E6. DUAL-PLUMBED SYSTEMS TESTING/MONITORING

Requirement	Frequency	Reporting Frequency	Notes
Cross Connection Testing	Four Years	30 days/Annually	Note a and b
Backflow incident	Continuous	24 hours from discovery	---
Backflow Prevention Device Testing and Maintenance	Annually	Annually	Note c

Footnotes for Table E6

- a. Testing shall be performed at least every 4 years, or more frequently at the discretion of DDW.
- b. Cross connection testing shall be reported pursuant to 22 CCR § 60314. The report shall be submitted to DDW within 30 days and included in the annual report to the Los Angeles Water Board.
- c. Backflow prevention device maintenance shall be tested by a qualified person as described in 17 CCR § 7605.

End of Footnotes for Table E6

6. Report Submittal Dates

Monitoring periods and reporting for all required monitoring shall be completed according to the following schedule:

TABLE E7. MONITORING PERIODS AND REPORTING SCHEDULE

Sampling Frequency	Monitoring Period Begins On...	Monitoring Period	SMR Due Date
Continuous	Permit effective date	All	Submit with quarterly report
Daily	Permit effective date	(Midnight through 11:59 PM) or any 24-hour period that reasonably represents a calendar day for purposes of sampling.	Submit with quarterly report
Weekly	Sunday following permit effective date or on permit effective date if on a Sunday	Sunday through Saturday	Submit with quarterly report
Monthly	First day of calendar month following permit effective date or on permit effective date if that date is first day of the month	1 st day of calendar month through last day of calendar month	By the 10 th day of the month following the month of sampling
Quarterly	Closest of January 1, April 1, July 1, or October 1 following (or on) permit effective date	January 1 through March 31 April 1 through June 30 July 1 through September 30 October 1 through December 31	May 15 August 15 November 15 February 15
Semiannually	Closest of January 1 or July 1 following (or on) permit effective date	January 1 through June 30 July 1 through December 31	Submit with corresponding quarterly report.
Annually	January 1 following (or on) permit effective date	January 1 through December 31	April 15

Sampling Frequency	Monitoring Period Begins On...	Monitoring Period	SMR Due Date
Volumetric Annual reporting	January 1 following (or on) permit effective date	January 1 through December 31	April 30

7. Certification Statement

Each report shall include the following declaration:

“I certify under penalty of law that I have personally examined and am familiar with the information submitted in this document and all attachments thereto; and that, based on my inquiry of the individuals immediately responsible for obtaining the information, I believe that the information is true, accurate, and complete. I am aware that there are significant penalties for submitting false information, including the possibility of fine and imprisonment.”

Executed on the _____ day of _____ at _____.

_____ (Signature)

_____ (Title)

8. Operations and Maintenance Manual

The Permittee shall submit an Operations and Maintenance Manual (OMM) for the recycled water system and submit it to the Los Angeles Water Board and DDW within 180 days of the effective date of this Order. The OMM shall include at a minimum process optimization, alarm set points, diversion and off-spec contingencies, instrument calibration and maintenance.

9. Climate Change Vulnerability Assessment and Management Plan

The City shall develop a Climate Change Effects Vulnerability Assessment and Management Plan (Climate Change Plan) and submit the Climate Change Plan to the Los Angeles Water Board for the Executive Officer’s approval no later than 12 months after the effective date of this Order. The Climate Change plan shall include an assessment of short-term and long-term vulnerabilities of the AWTF, all treatment systems, the collection system, recycled water distribution system, outfalls, and operations for predicted impacts in order to ensure that the facility operations are not disrupted, compliance with permit conditions is achieved, and receiving waters are not adversely impacted by discharges. Control measures shall include, but are not limited to, emergency procedures, contingency plans, alarm/notification systems, training, backup power and equipment, and the need for planned mitigation measures to ameliorate climate-induced impacts including, but not limited to changing influent and receiving water quality conditions, as well as the impact of rising sea level (where applicable), wildfires, storm surges, and back-to-back severe storms that are expected to become more frequent.

ATTACHMENT F – DDW CONDITIONAL ACCEPTANCE LETTER



State Water Resources Control Board Division of Drinking Water

August 19, 2020

Renee Purdy
Executive Officer
Los Angeles Regional Water Quality Control Board
320 W. 4th Street, Suite 200, 1st floor
Los Angeles, CA 90013

CONDITIONAL ACCEPTANCE LETTER FOR THE CITY OF SANTA MONICA RECYCLED WATER ENGINEERING REPORT FOR THE SUSTAINABLE WATER INFRASTRUCTURE PROJECT (1995004-703)

Dear Ms. Purdy,

This letter transmits the State Water Resources Control Board's Division of Drinking Water (Division) conditional acceptance of the Title 22 Engineering Report (Report) submitted by the City of Santa Monica (City), entitled "Recycled Water Engineering Report", dated July 16, 2020. This Report is for the production, distributions, and use of recycled water from the City's new advanced water treatment facility (AWTF) for non-potable reuse purposes. A previous engineering report was submitted by the City on April 22, 2020 which the Division reviewed for compliance with the California Water Recycling Criteria (Title 22) requirements and issued review comments in a letter dated June 1, 2020. The Division reviewed the July 16, 2020 Report and finds that it addressed the previous review comments.

The City must implement all applicable recycled water requirements found in Title 17 and Title 22 for production and use of recycled water in addition to the requirements below:

1. Prior to start of operations and delivery of recycled water, an Operations and Maintenance Manual for the AWTF must be submitted to the Division for review and acceptance.
2. The City must submit an updated engineering report to the Division for review and acceptance if any changes to the information provided in the current Report are considered in the future.
3. Sampling of the recycled water for total coliform bacteria must be conducted daily in accordance with Title 22 section 60301.230.
4. Each UV disinfection train must be operated independently to deliver a minimum validated UV dose of 300 mJ/cm² at all times.

E. JOAQUIN ESQUIVEL, CHAIR | EILEEN SOBECK, EXECUTIVE DIRECTOR

1350 Front Street, Room 2050, San Diego, CA 92101 | www.waterboards.ca.gov

Renee Purdy
Los Angeles Regional Water Board

- 2 -

August 19, 2020

Division of Drinking Water
State Water Resources Control Board
1350 Front St., Rm. 2050
San Diego, CA 92101

cc:

Sunny Wang, City of Santa Monica, Public Works Department – Water Resources (via email: sunny.wang@smgov.net)

Sutida Bergquist, Central District, State Water Resources Control Board – Division of Drinking Water (via email)

Jeff O'Keefe, State Water Resources Control Board – Division of Drinking Water (via email)

Kurt Souza, State Water Resources Control Board – Division of Drinking Water (via email)

Brian Bernados, State Water Resources Control Board – Division of Drinking Water (via email)

Steven Webb, Los Angeles Regional Water Quality Control Board (via email)

Jeong-Hee Lim, Los Angeles Regional Water Quality Control Board (via email)

Cris Morris, Los Angeles Regional Water Quality Control Board (via email)

RWU File