

**State of California
California Regional Water Quality Control Board
Santa Ana Region**

3737 Main Street, Suite 500, Riverside, California 92501-3348
Phone (951) 782-4130 - FAX (951) 781-6288– TDD (951) 782-3221
<http://www.waterboards.ca.gov/santaana>

**ORDER NO. R8-2022-0002
NPDES NO. CA8000408**

WASTE DISCHARGE REQUIREMENTS AND
NATIONAL POLLUTANT DISCHARGE ELIMINATION SYSTEM PERMIT
FOR THE
ORANGE COUNTY WATER DISTRICT
GROUNDWATER REPLENISHMENT SYSTEM
ADVANCED WATER PURIFICATION FACILITY
EMERGENCY DISCHARGE TO REACH 1 OF THE SANTA ANA RIVER

The following Discharger is subject to waste discharge requirements as set forth in this Order:

Table 1. Discharger/Facility Information

Discharger/Operator	Orange County Water District
Name of Facility	Groundwater Replenishment System--Advanced Water Purification Facility (AWPF)
Facility Address	18700 Ward Street, Fountain Valley, CA 92708 Orange County
The U.S. Environmental Protection Agency and the Regional Water Quality Control Board have classified this discharge as a minor discharge.	

The discharge by the Orange County Water District (OCWD) from the discharge point identified below is subject to waste discharge requirements (WDRs) as set forth in this Order:

Table 2. Discharge Location

Discharge Point	Effluent Description	Discharge Point Latitude	Discharge Point Longitude	Receiving Water
001	Tertiary treated effluent during emergency events, such as peak flows that approach or exceed the capacity of the Orange County Sanitation District's outfall and thereby threaten the integrity of the outfall	33°41'13" N	117°56'22" W	Reach 1 Santa Ana River

Table 3. Administrative Information

This Order was adopted by the Regional Water Quality Control Board on:	March 18, 2022
This Order shall become effective on:	April 1, 2022
This Order expires on:	March 31, 2027
The Discharger shall file a Report of Waste Discharge in accordance with title 23, California Code of Regulations, as application for issuance of new waste discharge requirements no later than:	October 2, 2026

IT IS HEREBY ORDERED, that in order to meet the provisions contained in division 7 of the California Water Code (CWC) and regulations adopted thereunder and the provisions of the federal Clean Water Act (CWA) and regulations and guidelines adopted thereunder, the Discharger shall comply with the requirements in this Order.

I, Jayne Joy, Executive Officer, do hereby certify that this Order with all attachments is a full, true, and correct copy of an Order adopted by the California Regional Water Quality Control Board, Santa Ana Region, on March 18, 2022.

 Digitally signed by Jayne Joy
Date: 2022.03.29 11:46:56 -07'00'

Jayne Joy, P.E., Executive Officer

Table of Contents

I.	Discharger/Facility Information	5
II.	Findings	5
III.	Discharge Prohibitions.....	6
IV.	Effluent Limitations and Discharge Specifications	6
	A. Effluent Limitations – Discharge Point 001	6
	1. Final Effluent Limitations.....	6
	2. Ammonia-N Effluent Limits	7
	3. Tertiary Treatment Requirements	8
	B. Land Discharge Specifications – Not Applicable.....	9
	C. Reclamation Specifications – Not Applicable.....	9
	D. Stormwater Discharge Specifications - Not Applicable (see Attachment F for discussion).....	9
V.	Receiving Water Limitations	9
	A. Surface Water Limitations.....	9
	B. Groundwater Limitations- Not Applicable.....	10
VI.	Provisions.....	10
	A. Standard Provisions.....	10
	B. Monitoring and Reporting Program Requirements.....	12
	C. Special Provisions.....	12
	1. Reopener Provisions.....	12
	2. Special Studies, Technical Reports and Additional Monitoring Requirements - Not applicable.....	13
	3. Best Management Practices and Pollution Prevention	13
	4. Construction, Operation and Maintenance Specifications – Not Applicable.....	14
	5. Special Provisions for Municipal Facilities (POTWs Only) – Not Applicable	14
	6. Other Special Provisions – Not Applicable.....	14
	7. Compliance Schedules – Not Applicable	14
VII.	Compliance Determination	14

List of Tables

Table 1.	Discharger/Facility Information	1
Table 2.	Discharge Location	1
Table 3.	Administrative Information	2
Table 4.	Discharger/Facility Information	5
Table 5.	Effluent Limitations at DP 001.....	7
Table 6.	Ammonia-N Effluent Limits at DP 001.....	7

List of Attachments

Attachment A – Definitions	A-1
Attachment B – Map	B-1
Attachment C – Flow Schematic.....	C-1
Attachment D – Standard Provisions.....	D-1
Attachment E – Monitoring and Reporting Program	E-1
Attachment F – Fact Sheet.....	F-1
Attachment G – EPA PPL Table.....	G-1
Attachment H – ML Table	H-1

I. DISCHARGER/FACILITY INFORMATION

Detailed information describing the OCWD's AWPf can be found in sections I and II of the Fact Sheet (Attachment F) of this Order. The following Discharger is subject to waste discharge requirements as set forth in this Order:

Table 4. Discharger/Facility Information

Discharger	Orange County Water District
Mailing Address	P.O. Box 8300, Fountain Valley, CA 92728-8300
Name of Facility	Groundwater Replenishment System (GWRS) – Advanced Water Purification Facility (AWPF)
Facility Address	18700 Ward Street, Fountain Valley, CA 92708
Facility Contact, Title, and Phone	Jason Dadakis, Executive Director of Water Quality and Technical Resources, phone: (714) 378-3200
Type of Facility	Water Recycling Facility (Tertiary treatment and disinfection only)
Facility Design Flow (treated effluent)	100 million gallons per day (mgd)

II. FINDINGS

The California Regional Water Quality Control Board, Santa Ana Region (hereinafter Santa Ana Water Board), finds:

- A. Legal Authorities.** This Order is issued pursuant to Chapter 5.5, Division 7 of the California Water Code (CWC) (§ 13370 et seq.) and the federal Clean Water Act (CWA) § 402 and implementing regulations adopted by the U.S. Environmental Protection Agency (USEPA). This Order serves as Waste Discharge Requirements (WDRs) pursuant to CWC Article 4, Chapter 4, § 13260 et seq.. It shall also serve as a NPDES permit for point source discharges from this facility to surface waters.
- B. Background and Rationale for Requirements.** The Santa Ana Water Board developed the requirements in this Order based on information submitted as part of the application, through monitoring and reporting programs, and other available information. The Fact Sheet (Attachment F), which contains background information and the rationale for Order requirements, is hereby incorporated into this Order and constitutes part of the Findings for this Order. Attachments A through E, G, and H are also incorporated into this Order.
- C. California Environmental Quality Act (CEQA).** Under CWC § 13389, this action to adopt an NPDES permit is exempt from the provisions of CEQA, Public Resources Code § 21000 et seq. (*County of Los Angeles v. California State Water Resources Control Board* (2006) 143 Cal.App.4th 985, mod. (Nov. 6, 2006, B184034) 50 Cal.Rptr.3d 619, 632-636).

D. Notification of Interested Parties. The Santa Ana Water Board has notified the Discharger and interested agencies and persons of its intent to prescribe Waste Discharge Requirements for the discharge and has provided them with an opportunity to submit their written comments and recommendations. Details of notification are provided in the Fact Sheet of this Order.

E. Consideration of Public Comment. The Santa Ana Water Board, in a public meeting, heard and considered all comments pertaining to the discharge. Details of the Public Hearing are provided in the Fact Sheet of this Order.

III. DISCHARGE PROHIBITIONS

- A.** Treated wastewater discharged at Discharge Point (DP) 001 shall be limited to tertiary treated and disinfected effluent during emergency conditions¹.
- B.** The discharge of treated wastewater at a location or in a manner different from those described in this Order is prohibited, except as allowed by other waste discharge requirements or water reclamation requirements adopted by the Santa Ana Water Board.
- C.** The bypass or overflow of untreated wastewater or wastes to surface waters or surface water drainage courses is prohibited, except as allowed in Standard Provision I.G. of Attachment D, Federal Standard Provisions.
- D.** The discharge of any substances in concentrations toxic to animal or plant life is prohibited.
- E.** The discharge of any radiological, chemical, or biological warfare agent or high level radiological waste is prohibited.

IV. EFFLUENT LIMITATIONS AND DISCHARGE SPECIFICATIONS

A. Effluent Limitations – Discharge Point 001

1. Final Effluent Limitations

The Discharger shall maintain compliance with the following effluent limitations for the discharge of treated and disinfected wastewater at DP 001, with compliance measured at monitoring location M-001, as described in the attached Monitoring and Reporting Program (Attachment E):

¹ See definition of emergency discharge condition in Attachment A of this Order.

Table 5. Effluent Limitations at DP 001

Parameter	Units	Effluent Limitations				
		Average Monthly*	Average Weekly	Maximum Daily	Instantaneous Minimum	Instantaneous Maximum
Biochemical Oxygen Demand 5-day @ 20°C	mg/L	20	30	--	--	--
Total Suspended Solids	mg/L	20	30	--	--	--
pH	standard units	--	--	--	6.5	8.5
Total Chlorine Residual	mg/L	--	--	0.1	--	--

* The average monthly effluent limitation applies only if discharges occur for more than one day in a calendar month.

2. Ammonia-N Effluent Limits

The discharge at DP 001 shall not contain concentrations of total ammonia-nitrogen that exceed those values specified in Table 6 below corresponding to the pH of the discharge.

Table 6. Ammonia-N Effluent Limits at DP 001

pH	Maximum Daily (mg/L)	Average Monthly* (mg/L)
6.5	49	38
6.6	47	36
6.7	45	34
6.8	42	33
6.9	39	30
7.0	36	28
7.1	33	25
7.2	30	23
7.3	26	20
7.4	23	18
7.5	20	15

Table 6. Ammonia-N Effluent Limits at DP 001

pH	Maximum Daily (mg/L)	Average Monthly* (mg/L)
7.6	17	13
7.7	14	11
7.8	12	9.4
7.9	10	7.8
8.0	8.4	6.5
8.1	7.0	5.4
8.2	5.7	4.4
8.3	4.7	3.6
8.4	3.9	3.0
8.5	3.2	2.5

* The Average Monthly Effluent Limitation applies only if discharges occur for more than one day in a calendar month.

3. Tertiary Treatment Requirements

The discharge shall at all times be adequately oxidized, filtered, and disinfected treated wastewater and shall meet the following limitations.

- (1) The turbidity of disinfected tertiary recycled water that is passed through a microfiltration, ultrafiltration, nanofiltration, or reverse osmosis membrane shall not exceed any of the following:
 - (a) 0.2 Nephelometric Turbidity Unit (NTU) more than 5 percent of the time within a 24-hour period; and;
 - (b) 0.5 NTU at any time.

- (2) The disinfected effluent shall meet the following:
 - (a) UV disinfection shall meet the requirements specified in the Ultraviolet Disinfection Guidelines for Drinking Water and Water Reuse, published by the National Water Research Institute, Second Edition, and/or the acceptance conditions specified by the California State Water Resources Control Board's Division of Drinking Water² (SWRCB's DDW). The facility must be operated and maintained in accordance with a SWRCB's DDW approved operations plan, which is part of the Title 22 Engineering Report.

² Or before July 1, 2014 the California Department of Public Health

The operations plan included in the Title 22 Engineering Report shall become an enforceable part of this Order.

- (b) When a disinfection process combined with the filtration process is utilized, the combined process shall demonstrate inactivation and/or removal of 99.999 percent of the plaque-forming units of F-specific bacteriophage MS2, or polio virus in the wastewater. A virus that is at least as resistant to disinfection as polio virus may be used for purposes of the demonstration.
- (c) The daily average concentration of total coliform bacteria shall not exceed a Most Probable Number (MPN) of 2.2 total coliform bacteria per 100 milliliters (ml).

B. Land Discharge Specifications – Not Applicable

C. Reclamation Specifications – Not Applicable

D. Stormwater Discharge Specifications - Not Applicable (see Attachment F for discussion)

V. RECEIVING WATER LIMITATIONS

A. Surface Water Limitations

1. Receiving water limitations are based upon water quality objectives contained in the Basin Plan. As such, they are a required part of this Order. The discharge shall not cause the following in Reach 1 of Santa Ana River and downstream:
 - a. Coloration of the receiving waters, which causes a nuisance or adversely affects beneficial uses.
 - b. Deposition of oil, grease, wax or other materials in the receiving waters in concentrations which result in a visible film or in coating objects in the water, or which cause a nuisance or affect beneficial uses.
 - c. An increase in the amounts of suspended or settleable solids in the receiving waters, which will cause a nuisance or adversely affect beneficial uses as a result of controllable water quality factors.
 - d. Taste or odor-producing substances in the receiving waters at concentrations, which cause a nuisance or adversely affect beneficial uses.
 - e. The presence of radioactive materials in the receiving waters in concentrations, which are deleterious to human, plant or animal life.
 - f. The depletion of the dissolved oxygen concentration below 5.0 mg/L.

- g. The temperature of the receiving waters to be raised above 90°F (32°C) during the period of June through October, or above 78°F (26°C) during the rest of the year.
 - h. The concentration of pollutants in the water column, sediments, or biota to adversely affect the beneficial uses of the receiving water. The discharge shall not result in the degradation of surface water communities and populations, including vertebrate, invertebrate, and plant species.
2. The discharge of wastes shall not cause a violation of any applicable water quality standards for receiving waters adopted by the Santa Ana Water Board or State Water Board, as required by the Clean Water Act and regulations adopted thereunder.
3. Pollutants not specifically mentioned and limited in this Order shall not be discharged at levels that will bioaccumulate in aquatic resources to levels that are harmful to human health.

B. Groundwater Limitations- Not Applicable

VI. PROVISIONS

A. Standard Provisions

1. The Discharger shall comply with all Federal Standard Provisions included in Attachment D of this Order.
2. The Discharger shall also comply with the following provisions. Failure to comply with provisions or requirements of this Order, or violation of other applicable laws or regulations governing discharges from this Facility, may subject the Discharger to administrative or civil liabilities, criminal penalties, and/or other enforcement remedies to ensure compliance. Additionally, certain violations may subject the Discharger to civil or criminal enforcement from appropriate local, state, or federal law enforcement entities.
 - a. In the event the Discharger does not comply or will be unable to comply for any reason with any prohibition, discharge limitations (e.g., maximum daily effluent limitation), or receiving water limitation of this Order, the Discharger shall notify the Santa Ana Water Board by telephone (951) 782-4130 or by email to info8@waterboards.ca.gov within 24 hours of having knowledge of such noncompliance, and shall confirm this notification in the monthly Self-Monitoring Report, unless the Santa Ana Water Board waives confirmation or requires, orally or in writing, a written notification within five business days. The written notification shall state the nature, time, duration, and cause of noncompliance, and shall describe the measures being taken to remedy the current noncompliance and, prevent recurrence including, where applicable, a schedule

- of implementation. Other noncompliance requires written notification with the details discussed above with the next monitoring report.
- b. Neither the treatment nor the discharge of pollutants shall create a pollution, contamination, or nuisance as defined by CWC § 13050.
 - c. The Discharger shall take all reasonable steps to minimize or correct any adverse impact on the environment resulting from noncompliance with this Order, including such accelerated or additional monitoring as may be necessary to determine the nature and impact of the noncomplying discharge.
 - d. This Order may be modified, revoked and reissued, or terminated for cause including, but not limited to, the following:
 - (1) Violation of any terms or conditions of this Order;
 - (2) Obtaining this Order by misrepresentation or failure to disclose fully all relevant facts, or;
 - (3) In addition to any other grounds specified herein, this Order may be modified or revoked at any time if, on the basis of any data, the Santa Ana Water Board determines that continued discharges may cause unreasonable degradation of the aquatic environment.
 - e. If an effluent standard or discharge prohibition (including any schedule of compliance specified in such effluent standard or prohibition) is established under CWA § 307 (a) for a toxic pollutant which is present in the discharge, and such standard or prohibition is more stringent than any limitation for that pollutant in this Order, this Order may be modified or revoked and reissued to conform to the effluent standard or discharge prohibition.
 - f. The Discharger shall file with the Santa Ana Water Board a Report of Waste Discharge at least 180 days before making any material change in the character, location, or volume of the discharge. A material change includes, but is not limited to, the following:
 - (1) Adding a major industrial waste discharge to a discharge of essentially domestic sewage, adding a new process, or product by an industrial facility resulting in a change in the character of the waste.
 - (2) Significantly changing the disposal method or location, such as changing the disposal to another drainage area or water body.
 - (3) Significantly changing the method of treatment.
 - g. The provisions of this Order are severable, and if any provision of this Order, or the application of any provision of this Order to any circumstance, is held invalid, the application of such provision to other circumstances, and the remainder of this Order, shall not be affected thereby.

- h. The Discharger shall maintain a copy of this Order at the site so that it is available to site operating personnel at all times. Key operating personnel shall be familiar with its content.
- i. If the Discharger demonstrates a correlation between the biological oxygen demand (BOD₅) and total organic carbon (TOC) concentrations in the effluent to the satisfaction of the Executive Officer, compliance with the BOD₅ limits contained in this Order may be determined based on analyses of the TOC of the effluent.
- j. In the event of any change in control or ownership of land or waste discharge facility presently owned or controlled by the Discharger, the Discharger shall notify the succeeding owner or operator of the existence of this Order by letter, a copy of which shall be forwarded to the Santa Ana Water Board.

B. Monitoring and Reporting Program Requirements

The Discharger shall comply with the Monitoring and Reporting Program, and future revisions thereto, in Attachment E of this Order. This monitoring and reporting program may be modified by the Executive Officer at any time during the term of this Order and may include an increase in the number of parameters to be monitored, the frequency of the monitoring or the number and size of samples to be collected. Any increase in the number of parameters to be monitored, the frequency of the monitoring or the number and size of samples to be collected may be reduced back to the levels specified in the original monitoring and reporting program at the discretion of the Executive Officer.

C. Special Provisions

1. Reopener Provisions

- a. This Order will be reopened to address any changes in State or federal plans, policies or regulations that would affect the quality requirements for the discharges.
- b. This Order may be reopened to include effluent limitations for pollutants determined to be present in the discharge in concentrations that pose a reasonable potential to cause or contribute to violations of water quality objectives.
- c. This Order may be reopened and modified in accordance with the requirements set forth at 40 CFR 122 and 124, to include the appropriate conditions or limits to address demonstrated effluent toxicity based on newly available information, or to implement any EPA-approved new State water quality standards applicable to effluent toxicity. This Order may be reopened for modification, or revocation and reissuance, as a result of the detection of a reportable priority pollutant generated by special conditions included in this Order. These special conditions may be, but are not limited to, fish tissue sampling, whole effluent toxicity, monitoring requirements on internal waste stream(s), and monitoring for surrogate

parameters. Additional requirements may be included in this Order as a result of the special condition monitoring data.

2. Special Studies, Technical Reports and Additional Monitoring Requirements - Not applicable

3. Best Management Practices and Pollution Prevention

a. Pollutant Minimization Program

(1) The Discharger shall develop and conduct a Pollutant Minimization Program (PMP) as further described below when there is evidence (e.g., sample results reported as DNQ when the effluent limitation is less than the MDL, sample results from analytical methods more sensitive than those methods required by this Order, presence of whole effluent toxicity, health advisories for fish consumption, results of benthic or aquatic organism tissue sampling) that a priority pollutant is present in the effluent above an effluent limitation and either:

- (a) A sample result is reported as DNQ and the effluent limitation is less than the RL; or
- (b) A sample result is reported as ND and the effluent limitation is less than the MDL.

(2) The PMP shall include, but not be limited to, the following actions and submittals acceptable to the Santa Ana Water Board:

- (a) An annual review and semi-annual monitoring of potential sources of the reportable priority pollutant(s), which may include fish tissue monitoring and other bio-uptake sampling;
- (b) Quarterly monitoring for the reportable priority pollutant(s) in the influent to the wastewater treatment system;
- (c) Submittal of a control strategy designed to proceed toward the goal of maintaining concentrations of the reportable priority pollutant(s) in the effluent at or below the effluent limitation;
- (d) Implementation of appropriate cost-effective control measures for the reportable priority pollutant(s), consistent with the control strategy; and
- (e) An annual status report that shall be sent to the Santa Ana Water Board including:
 - i. All PMP monitoring results for the previous year;
 - ii. A list of potential sources of the reportable priority pollutant(s);
 - iii. A summary of all actions undertaken pursuant to the control strategy; and
 - iv. A description of actions to be taken in the following year.

- 4. Construction, Operation and Maintenance Specifications – Not Applicable**
- 5. Special Provisions for Municipal Facilities (POTWs Only) – Not Applicable**
- 6. Other Special Provisions – Not Applicable**
- 7. Compliance Schedules – Not Applicable**

VII. COMPLIANCE DETERMINATION

Compliance with the effluent limitations contained in section IV of this Order will be determined as specified below:

A. General.

Compliance with effluent limitations for priority pollutants shall be determined using sample reporting protocols defined in the MRP and Attachment A of this Order. For purposes of reporting and administrative enforcement by the Regional and State Water Boards, the Discharger shall be deemed out of compliance with effluent limitations if the concentration of the priority pollutant in the monitoring sample is greater than the effluent limitation and greater than or equal to the reporting level (RL).

B. Multiple Sample Data.

When determining compliance with an AMEL or MDEL for priority pollutants and more than one sample result is available, the Discharger shall compute the arithmetic mean unless the data set contains one or more reported determinations of “Detected, but Not Quantified” (DNQ) or “Not Detected” (ND). In those cases, the Discharger shall compute the median in place of the arithmetic mean in accordance with the following procedure:

1. The data set shall be ranked from low to high, ranking the reported ND determinations lowest, DNQ determinations next, followed by quantified values (if any). The order of the individual ND or DNQ determinations is unimportant.
2. The median value of the data set shall be determined. If the data set has an odd number of data points, then the median is the middle value. If the data set has an even number of data points, then the median is the average of the two values around the middle unless one or both of the points are ND or DNQ, in which case the median value shall be the lower of the two data points where DNQ is lower than a value and ND is lower than DNQ.

C. Average Monthly Effluent Limitation (AMEL).

If the average (or when applicable, the median determined by subsection B above for multiple sample data) of daily discharges over a calendar month exceeds the AMEL for a given parameter, this will represent a single violation, though the Discharger will be considered out of compliance for each day of that month for that parameter (e.g., resulting in 31 days of non-compliance in a 31-day month). If only a single sample is taken during the calendar month and the analytical result for that sample exceeds the

AMEL, the Discharger will be considered out of compliance for that calendar month. The Discharger will only be considered out of compliance for days when the discharge occurs. For any one calendar month during which no sample (daily discharge) is taken, no compliance determination can be made for that calendar month.

D. Average Weekly Effluent Limitation (AWEL).

If the average or when applicable, the median determined by subsection B above for multiple sample data of daily discharges over a calendar week exceeds the AWEL for a given parameter, this will represent a single violation, though the Discharger will be considered out of compliance for each day of that week for that parameter, resulting in 7 days of non-compliance. If only a single sample is taken during the calendar week and the analytical result for that sample exceeds the AWEL, the Discharger will be considered out of compliance for that calendar week. The Discharger will only be considered out of compliance for days when the discharge occurs. For any one calendar week during which no sample (daily discharge) is taken, no compliance determination can be made for that calendar week.

E. Maximum Daily Effluent Limitation (MDEL).

If a daily discharge or when applicable, the median determined by subsection B above for multiple sample data of a daily discharge exceeds the MDEL for a given parameter, the Discharger will be considered out of compliance for that parameter for that 1 day only within the reporting period. For any 1 day during which no sample is taken, no compliance determination can be made for that day.

F. Instantaneous Minimum Effluent Limitation.

If the analytical result of a single grab sample is lower than the instantaneous minimum effluent limitation for a parameter, the Discharger will be considered out of compliance for that parameter for that single sample. Non-compliance for each sample will be considered separately (e.g., the results of two grab samples taken within a calendar day that both are lower than the instantaneous minimum effluent limitation would result in two instances of non-compliance with the instantaneous minimum effluent limitation).

G. Instantaneous Maximum Effluent Limitation.

If the analytical result of a single grab sample is higher than the instantaneous maximum effluent limitation for a parameter, the Discharger will be considered out of compliance for that parameter for that single sample. Non-compliance for each sample will be considered separately (e.g., the results of two grab samples taken within a calendar day that both exceed the instantaneous maximum effluent limitation would result in two instances of non-compliance with the instantaneous maximum effluent limitation).

H. Priority Pollutants.

The Discharger shall be deemed out of compliance with an effluent limitation if the concentration of the priority pollutant in the monitoring sample is greater than the effluent limitation.

1. Compliance determination shall be based on the reporting level selected from minimum level (ML)³ specified in Attachment “H” of this Order, unless an alternative reporting level is approved by the Santa Ana Water Board’s Executive Officer. When there is more than one ML value for a given substance, the Discharger shall select the ML value that is below the calculated effluent limitation, and use its associated analytical method, listed in Attachment “I” of this Order. If no ML value is below the effluent limitation, then the Santa Ana Water Board will select as the reporting level the lowest ML value and its associated analytical method.
2. When determining compliance with an average monthly limit and more than one sample result is available in a month, the Discharger shall compute the arithmetic mean unless the data set contains one or more reported determinations of detected but not quantified (DNQ) or not detected (ND). In those cases, the Discharger shall compute the median in place of the arithmetic mean in accordance with the following procedure:
 - a. The data set shall be ranked from low to high, reported ND determinations lowest, DNQ determinations next, followed by quantified values (if any). The order of the individual ND or DNQ determinations is unimportant.
 - b. The median value of the data set shall be determined. If the data set has an odd number of data points, then the median is the middle value. If the data set has an even number of data points, then the median is the average of the two values around the middle unless one or both of the points are ND or DNQ, in which case the median value shall be the lower of the two data points where DNQ is lower than a value and ND is lower than DNQ. If a sample result, or the arithmetic mean or median of multiple sample results, is below the reporting level, and there is evidence that the priority pollutant is present in the effluent above an effluent limitation and the Discharger conducts a pollutant minimization program (PMP)⁴ the Discharger shall not be deemed out of compliance.

I. Non-Priority Pollutants.

The discharge shall be considered to be in compliance with an effluent limitation that is less than or equal to the method detection limit (MDL) specified in 40 CFR 136 if the arithmetic mean of all test results for the monitoring period is less than the constituent effluent limitation. Analytical results that are less than the specified MDL shall be assigned a value of zero.

J. Compliance Determination

³ *Minimum level is the concentration at which the entire analytical system must give a recognizable signal and acceptable calibration point. The ML is the concentration in a sample that is equivalent to the concentration of the lowest calibration standard analyzed by a specific analytical procedure, assuming that all the method specified sample weights, volumes, and processing steps have been followed.*

⁴ *The goal of the PMP shall be to reduce all potential sources of a priority pollutant(s) through pollutant minimization (control) strategies, including pollution prevention measures as appropriate, to maintain the effluent concentration at or below the water quality-based effluent limitation.*

Compliance determinations shall be based on available analyses for the time interval associated with the effluent limitation. Where only one sample analysis is available in a specified time interval (e. g., monthly or weekly average), that sample shall serve to characterize the discharge for the entire interval. If quarterly sample results show noncompliance with the average monthly limit and that sample result is used for compliance determinations for each month of the quarter, then three separate violations of the average monthly limit shall be deemed to have occurred.

Compliance with a single effluent limitation which applies to a group of chemicals (e.g., PCBs), based on a single sample shall be determined by considering the concentrations of individual members of the group to be zero if the analytical response for the individual chemical falls below the method detection limit (MDL) for that chemical.

ATTACHMENT A – DEFINITIONS

Arithmetic Mean (μ), also called the average, is the sum of measured values divided by the number of samples. For ambient water concentrations, the arithmetic mean is calculated as follows:

Arithmetic mean = $\mu = \Sigma x / n$ where: Σx is the sum of the measured ambient water concentrations, and n is the number of samples.

Average Monthly Effluent Limitation (AMEL): the highest allowable average of daily discharges over a calendar month, calculated as the sum of all daily discharges measured during a calendar month divided by the number of daily discharges measured during that month.

Average Weekly Effluent Limitation (AWEL): the highest allowable average of daily discharges over a calendar week (Sunday through Saturday), calculated as the sum of all daily discharges measured during a calendar week divided by the number of daily discharges measured during that week.

Best Management Practices (BMPs) are methods, measures, or practices designed and selected to reduce or eliminate the discharge of pollutants to surface waters from point and nonpoint source discharges including storm water. BMPs include structural and non-structural controls, and operation and maintenance procedures, which can be applied before, during, and/or after pollution producing activities.

Bioaccumulative pollutants are those substances taken up by an organism from its surrounding medium through gill membranes, epithelial tissue, or from food and subsequently concentrated and retained in the body of the organism.

Carcinogenic pollutants are substances that are known to cause cancer in living organisms.

Coefficient of Variation (CV) is a measure of the data variability and is calculated as the estimated standard deviation divided by the arithmetic mean of the observed values.

Criteria Continuous Concentration (CCC) equals the highest concentration of a pollutant to which aquatic life can be exposed for an extended period of time (4 days) without deleterious effects.

Criteria Maximum Concentration (CMC) equals the highest concentration of a pollutant to which aquatic life can be exposed for a short period of time without deleterious effects.

Daily Discharge: Daily Discharge is defined as either: (1) the total mass of the constituent discharged over the calendar day (12:00 am through 11:59 pm) or any 24-hour period that reasonably represents a calendar day for purposes of sampling (as specified in the permit), for a constituent with limitations expressed in units of mass or; (2) the unweighted arithmetic mean measurement of the constituent over the day for a constituent with limitations expressed in other units of measurement (e.g., concentration).

The daily discharge may be determined by the analytical results of a composite sample taken over the course of one day (a calendar day or other 24-hour period defined as a day) or by the arithmetic mean of analytical results from one or more grab samples taken over the course of the day.

For composite sampling, if 1 day is defined as a 24-hour period other than a calendar day, the analytical result for the 24-hour period will be considered as the result for the calendar day in which the 24-hour period ends.

Detected, but Not Quantified (DNQ) are those sample results less than the RL, but greater than or equal to the laboratory's MDL.

Effluent Concentration Allowance (ECA) is a value derived from the water quality criterion/objective, dilution credit, and ambient background concentration that is used, in conjunction with the coefficient of variation for the effluent monitoring data, to calculate a long-term average (LTA) discharge concentration. The ECA has the same meaning as waste load allocation (WLA) as used in USEPA guidance (Technical Support Document For Water Quality-based Toxics Control, March 1991, second printing, EPA/505/2-90-001).

Emergency Discharge Conditions: Are periods when the OCWD's Advanced Water Treatment Facility (AWTF) will provide flow relief when peak wastewater flows at Orange County Sanitation District approach the capacity of the ocean outfall and thereby threaten the integrity of the outfall and the wastewater treatment facility or when the Orange County Sanitation District ocean outfall is being repaired.

Estimated Chemical Concentration is the estimated chemical concentration that results from the confirmed detection of the substance by the analytical method below the ML value.

Existing Discharger means any discharger that is not a new discharger. An existing discharger includes an "increasing discharger" (i.e., an existing facility with treatment systems in place for its current discharge that is or will be expanding, upgrading, or modifying its existing permitted discharge after the effective date of this Policy).

Infeasible means not capable of being accomplished in a successful manner within a reasonable period of time, taking into account economic, environmental, legal, social, and technological factors.

Inland Surface Waters are all surface waters of the State that do not include the ocean, enclosed bays, or estuaries.

Instantaneous Maximum Effluent Limitation: the highest allowable value for any single grab sample or aliquot (i.e., each grab sample or aliquot is independently compared to the instantaneous maximum limitation).

Instantaneous Minimum Effluent Limitation: the lowest allowable value for any single grab sample or aliquot (i.e., each grab sample or aliquot is independently compared to the instantaneous minimum limitation).

Maximum Daily Effluent Limitation (MDEL) means the highest allowable daily discharge of a pollutant, over a calendar day (or 24-hour period). For pollutants with limitations expressed in units of mass, the daily discharge is calculated as the total mass of the pollutant discharged over the day. For pollutants with limitations expressed in other units of measurement, the daily discharge is calculated as the arithmetic mean measurement of the pollutant over the day.

Maximum Daily Flow is the maximum flow sample of all samples collected in a calendar day.

MEC: Maximum Effluent Concentration.

Median is the middle measurement in a set of data. The median of a set of data is found by first arranging the measurements in order of magnitude (either increasing or decreasing order). If the number of measurements (n) is odd, then the median = $X_{(n+1)/2}$. If n is even, then the median = $(X_{n/2} + X_{(n/2)+1})/2$ (i.e., the midpoint between the $n/2$ and $n/2+1$).

Method Detection Limit (MDL) is the minimum concentration of a substance that can be measured and reported with 99 percent confidence that the analyte concentration is greater than zero, as defined in title 40 of the Code of Federal Regulations, Part 136, Appendix B, revised as of July 3, 1999 or as defined in the latest official revision of 40 CFR, Part 136, Appendix B.

Minimum Level (ML) is the concentration at which the entire analytical system must give a recognizable signal and acceptable calibration point. The ML is the concentration in a sample that is equivalent to the concentration of the lowest calibration standard analyzed by a specific analytical procedure, assuming that all the method specified sample weights, volumes, and processing steps have been followed.

Mixing Zone is a limited volume of receiving water that is allocated for mixing with a wastewater discharge where water quality criteria can be exceeded without causing adverse effects to the overall water body.

New Discharger includes any building, structure, facility, or installation from which there is, or may be, a discharge of pollutants, the construction of which commenced after the effective date of this Policy.

Not Detected (ND) are those sample results less than the laboratory's MDL.

Ocean Waters are the territorial marine waters of the State as defined by California law to the extent these waters are outside of enclosed bays, estuaries, and coastal lagoons. Discharges to ocean waters are regulated in accordance with the State Water Board's California Ocean Plan.

Objectionable Bottom Deposits are an accumulation of materials or substances on or near the bottom of a water body, which creates conditions that adversely impact aquatic life, human health, beneficial uses, or aesthetics. These conditions include, but are not limited to, the accumulation of pollutants in the sediments and other conditions that result in harm to benthic organisms, production of food chain organisms, or fish egg development. The presence of such deposits shall be determined by RWQCB(s) on a case-by-case basis.

Persistent pollutants are substances for which degradation or decomposition in the environment is nonexistent or very slow.

Pollutant Minimization Program (PMP) means waste minimization and pollution prevention actions that include, but are not limited to, product substitution, waste stream recycling, alternative waste management methods, and education of the public and businesses. The goal of the PMP shall be to reduce all potential sources of a priority pollutant(s) through pollutant minimization (control) strategies, including pollution prevention measures as appropriate, to maintain the effluent concentration at or below the water quality-based effluent limitation. Pollution prevention measures may be particularly appropriate for persistent bioaccumulative priority pollutants where there is evidence that beneficial uses are being impacted. The Regional Water Board may consider cost effectiveness when establishing the requirements of a PMP. The completion and implementation of a Pollution Prevention Plan, if required pursuant to Water Code section 13263.3(d), shall be considered to fulfill the PMP requirements.

Pollution Prevention means any action that causes a net reduction in the use or generation of a hazardous substance or other pollutant that is discharged into water and includes, but is not limited to, input change, operational improvement, production process change, and product reformulation (as defined in Water Code section 13263.3). Pollution prevention does not include actions that merely shift a pollutant in wastewater from one environmental medium to another environmental medium, unless clear environmental benefits of such an approach are identified to the satisfaction of the State or Regional Water Board.

Reporting Level (RL) is the ML (and its associated analytical method) chosen by the Discharger for reporting and compliance determination from the MLs included in this Order. The MLs included in this Order correspond to approved analytical methods for reporting a sample result that are selected by the Regional Water Board either from Appendix 4 of the SIP in accordance with section 2.4.2 of the SIP or established in accordance with section 2.4.3 of the SIP. The ML is based on the proper application of method-based analytical procedures for sample preparation and the absence of any matrix interferences. Other factors may be applied to the ML depending on the specific sample preparation steps employed. For example, the treatment typically applied in cases where there are matrix-effects is to dilute the sample or

sample aliquot by a factor of ten. In such cases, this additional factor must be applied to the ML in the computation of the RL.

Satellite Collection System is the portion, if any, of a sanitary sewer system owned or operated by a different public agency than the agency that owns and operates the wastewater treatment facility that a sanitary sewer system is tributary to.

Use Attainability Analysis is a structured scientific assessment of the factors affecting the attainment of the use which may include physical, chemical, biological and economic factors as described in 40 CFR 131.10(g) (40 CFR 131.3, revised as of July 1, 1997).

Water Effect Ratio (WER) is an appropriate measure of the toxicity of a material obtained in a site water divided by the same measure of the toxicity of the same material obtained simultaneously in a laboratory dilution water.

12-Month Running Average Effluent Limitation (12-MRAEL): the highest allowable average of monthly discharges over the last twelve months, calculated as the sum of all monthly discharges measured during the last twelve months divided by the number of monthly discharges measured during that time period.

Attachment B – Location MAP

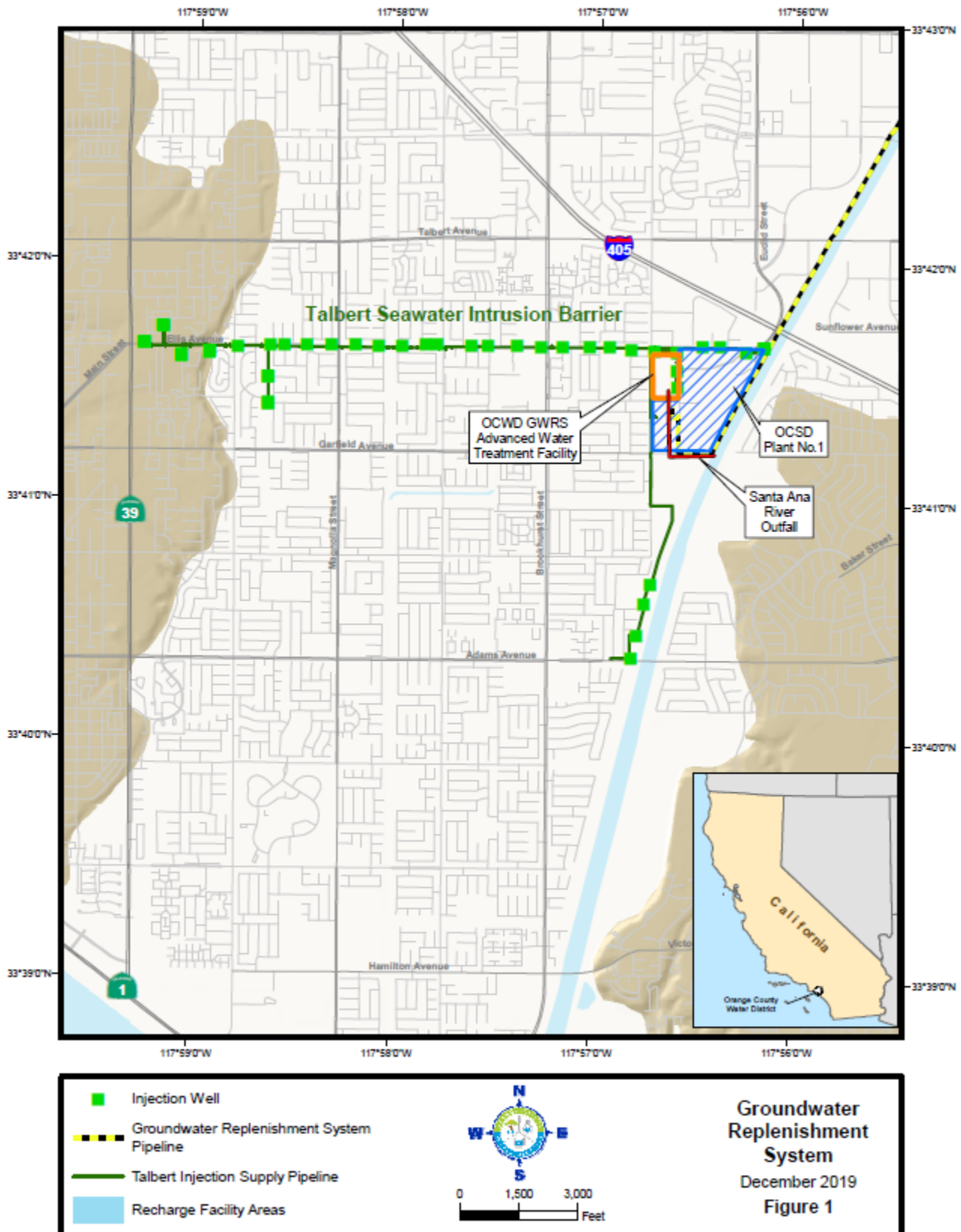

Attachment C – Flow Schematic

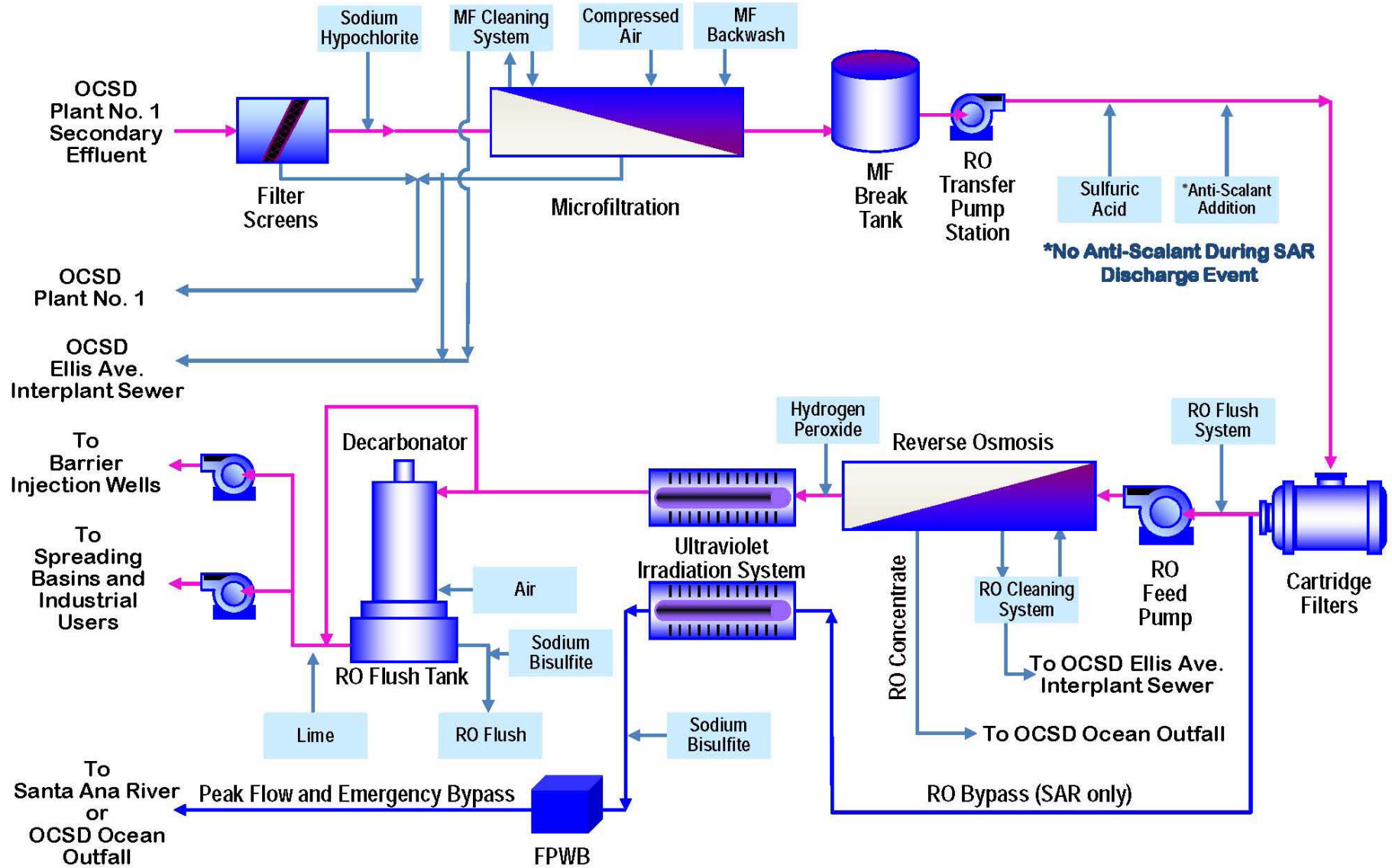

ATTACHMENT D – FEDERAL STANDARD PROVISIONS

I. Standard Provisions – Permit Compliance

A. Duty to Comply

1. The Discharger must comply with all of the conditions, terms, and requirements of this Order/permit. Any noncompliance constitutes a violation of the Clean Water Act (CWA) and the California Water Code (CWC) and is grounds for enforcement action: for Order/permit termination, revocation and reissuance, or modification; or denial of an Order/permit renewal application. (40 CFR § 122.41(a); CWC 13261, 13263, 13265, 13268, 13000, 13001, 13304, 13350, and 13385.)
2. The Discharger shall comply with effluent standards or prohibitions established under CWA § 307(a) for toxic pollutants within the time provided in the regulations that establish these standards or prohibitions even if this Order/permit has not yet been modified to incorporate the requirement. (40 CFR § 122.41(a)(1).)

B. Need to Halt or Reduce Activity Not a Defense

It shall not be a defense for a Discharger in an enforcement action that it would have been necessary to halt or reduce the permitted activity in order to maintain compliance with the conditions of this Order/Permit. (40 CFR § 122.41(c).)

C. Duty to Mitigate

The Discharger shall take all reasonable steps to minimize or prevent any discharge or sludge use or disposal in violation of this Order/permit that has a reasonable likelihood of adversely affecting human health or the environment. (40 CFR § 122.41(d).)

D. Proper Operation and Maintenance

The Discharger shall at all times properly operate and maintain all facilities and systems of treatment and control (and related appurtenances) which are installed or used by the Discharger to achieve compliance with the conditions of this Order/permit. Proper operation and maintenance also include adequate laboratory controls and appropriate quality assurance procedures. This provision requires the operation of backup or auxiliary facilities or similar systems that are installed by a Discharger only when necessary to achieve compliance with the conditions of this Order/permit. (40 CFR § 122.41(e).)

E. Property Rights

1. This Order/permit does not convey any property rights of any sort or any exclusive privileges. (40 CFR § 122.41(g).)

2. The issuance of this Order/permit does not authorize any injury to persons or property or invasion of other private rights, or any infringement of state or local law or regulations. (40 CFR § 122.5(c).)

F. Inspection and Entry

The Discharger shall allow the Santa Ana Water Board, State Water Board, United States Environmental Protection Agency (USEPA), and/or their authorized representatives (including an authorized contractor acting as their representative), upon the presentation of credentials and other documents as may be required by law, to (33 USC 1318(a)(4)(b); 40 CFR § 122.41(i); CWC § 13267, CWC § 13383.):

1. Enter upon the Discharger's premises where a regulated facility or activity is located or conducted, or where records are kept under the conditions of this Order/permit (33 USC 1318(a)(4)(b)(i); 40 CFR § 122.41(i)(1)); CWC § 13267, CWC § 13383.)
2. Have access to and copy, at reasonable times, any records that must be kept under the conditions of this Order/permit (33 USC 1318(a)(4)(b)(ii); 40 CFR § 122.41(i)(2)); CWC § 13267, CWC § 13383.)
3. Inspect and photograph, at reasonable times, any facilities, equipment (including monitoring and control equipment), practices, or operations regulated or required under this Order/permit (33 USC 1318(a)(4)(b)(ii); 40 CFR § 122.41(i)(3)); CWC § 13267, CWC § 13383.) and
4. Sample or monitor, at reasonable times, for the purposes of assuring Order/permit compliance or as otherwise authorized by the CWA or the CWC, any substances or parameters at any location. (33 USC 1318(a)(4)(b); 40 CFR § 122.41(i)(4); CWC § 13267, CWC § 13383.)

G. Bypass

1. Definitions
 - a. "Bypass" means the intentional diversion of waste streams from any portion of a treatment facility. (40 CFR § 122.41(m)(1)(i).)
 - b. "Severe property damage" means substantial physical damage to property, damage to the treatment facilities which causes them to become inoperable, or substantial and permanent loss of natural resources that can reasonably be expected to occur in the absence of a bypass. Severe property damage does not mean economic loss caused by delays in production. (40 CFR § 122.41(m)(1)(ii).)
2. Bypass not exceeding limitations. The Discharger may allow any bypass to occur which does not cause exceedances of effluent limitations, but only if it is for essential

maintenance to assure efficient operation. These bypasses are not subject to the provisions listed in Standard Provisions – Permit Compliance I.G.3, I.G.4, and I.G.5 below. (40 CFR § 122.41(m)(2).)

3. Prohibition of bypass. Bypass is prohibited, and the Santa Ana Water Board may take enforcement action against a Discharger for bypass, unless (40 CFR § 122.41(m)(4)(i)):
 - a. Bypass was unavoidable to prevent loss of life, personal injury, or severe property damage (40 CFR § 122.41(m)(4)(i)(A));
 - b. There were no feasible alternatives to the bypass, such as the use of auxiliary treatment facilities, retention of untreated wastes, or maintenance during normal periods of equipment downtime. This condition is not satisfied if adequate back-up equipment should have been installed in the exercise of reasonable engineering judgment to prevent a bypass that occurred during normal periods of equipment downtime or preventive maintenance (40 CFR § 122.41(m)(4)(i)(B)); and
 - c. The Discharger submitted notice to the Santa Ana Water Board as required under Standard Provisions – Permit Compliance I.G.5 below. (40 CFR § 122.41(m)(4)(i)(C).)
4. The Santa Ana Water Board may approve an anticipated bypass, after considering its adverse effects, if the Santa Ana Water Board determines that it will meet the three conditions listed in Standard Provisions – Permit Compliance I.G.3 above. (40 CFR § 122.41(m)(4)(ii).)
5. Notice
 - a. Anticipated bypass. If the Discharger knows in advance of the need for a bypass, it shall submit a notice, if possible, at least 10 days before the date of the bypass. The notice shall be sent to the Santa Ana Water Board. As of December 21, 2025, all notices submitted in compliance with this section must be submitted electronically to the Santa Ana Water Board, as defined in 40 CFR § 127.2(b), in compliance with this section and 40 CFR § 3 (including, in all cases, subpart D to part 3), 122.22 and part 127. Part 127 is not intended to undo existing requirements for electronic reporting. Prior to this date, and independent of part 127, the Discharger may be required to report electronically if specified by a particular Order/permit or if required to do so by State law. (40 CFR § 122.41(m)(3)(i).)
 - b. Unanticipated bypass. The Discharger shall submit notice of an unanticipated bypass as required in Attachment D. Standard Provisions - Reporting V.E below (24-hour notice). As of December 21, 2025 all notices submitted in compliance with this section must be submitted electronically by the Discharger to the Santa

Ana Water Board, as defined in 40 CFR § 127.2(b), in compliance with this section and 40 CFR § 3 (including, in all cases, subpart D to part 3), 122.22 and part 127. Part 127 is not intended to undo existing requirements for electronic reporting. Prior to this date, and independent of part 127, the Discharger may be required to report electronically if specified by a particular Order/permit or if required to do so by State law. (40 CFR § 122.41(m)(3)(ii).)

H. Upset

Upset means an exceptional incident in which there is unintentional and temporary noncompliance with technology-based permit effluent limitations because of factors beyond the reasonable control of the Discharger. An upset does not include noncompliance to the extent caused by operational error, improperly designed treatment facilities, inadequate treatment facilities, lack of preventive maintenance, or careless or improper operation. (40 CFR § 122.41(n)(1).)

1. Effect of an upset. An upset constitutes an affirmative defense to an action brought for noncompliance with such technology-based permit effluent limitations if the requirements of Standard Provisions – Permit Compliance I.H.2 below are met. No determination made during administrative review of claims that noncompliance was caused by upset, and before an action for noncompliance, is final administrative action subject to judicial review. (40 CFR § 122.41(n)(2).)
2. Conditions necessary for a demonstration of upset. A Discharger who wishes to establish the affirmative defense of upset shall demonstrate, through properly signed, contemporaneous operating logs or other relevant evidence that (40 CFR § 122.41(n)(3)):
 - a. An upset occurred and that the Discharger can identify the cause(s) of the upset (40 CFR § 122.41(n)(3)(i));
 - b. The permitted facility was, at the time, being properly operated (40 CFR § 122.41(n)(3)(ii));
 - c. The Discharger submitted notice of the upset as required in Standard Provisions – Reporting V.E.2.b below (24-hour notice) (40 CFR § 122.41(n)(3)(iii)); and
 - d. The Discharger complied with any remedial measures required under Standard Provisions – Permit Compliance I.C above. (40 CFR § 122.41(n)(3)(iv).)
3. Burden of proof. In any enforcement proceeding, the Discharger seeking to establish the occurrence of an upset has the burden of proof. (40 CFR § 122.41(n)(4).)

II. Standard Provisions – Permit Action

A. General

This Order/permit may be modified, revoked and reissued, or terminated for cause. The filing of a request by the Discharger for Order/permit modification, revocation and reissuance, or termination, or a notification of planned changes or anticipated noncompliance does not stay any Order/permit condition. (40 CFR § 122.41(f).)

B. Duty to Reapply

If the Discharger wishes to continue an activity regulated by this Order/permit after the expiration date of this Order/permit, the Discharger must apply for and obtain a new Order/permit. (40 CFR § 122.41(b).)

C. Transfers

This Order is not transferable to any person except after notice to the Santa Ana Water Board. The Santa Ana Water Board may require modification or revocation and reissuance of the Order/permit to change the name of the Discharger and incorporate such other requirements as may be necessary under the CWA and the CWC. (40 CFR § 122.41(l)(3); § 122.61.)

III. Standard Provisions – Monitoring

- A.** Samples and measurements taken for the purpose of monitoring shall be representative of the monitored activity. (40 CFR § 122.41(j)(1).)
- B.** Monitoring must be conducted according to test procedures under 40 CFR Part 136 for the analyses of pollutants unless another method is required under 40 CFR chapter I, subchapter N or O. (40 CFR § 122.41(j)(4).)
- C.** Monitoring for quantitative data shall be conducted in accordance with sufficiently sensitive analytical methods approved under 40 CFR Part 136 or required under 40 CFR chapter I, subchapter N or O. For the purposes of this requirement, a method approved under 40 CFR Part 136 or required under 40 CFR chapter I, subchapter N or O is “sufficiently sensitive” when:
 - 1. The method minimum level (ML) is at or below the level of the most stringent effluent limitation established in the Order/permit for the measured pollutant or pollutant parameter, and either the method ML is at or below the level of the most stringent applicable water quality criterion for the measured pollutant or pollutant parameter or the method ML is above the applicable water quality criterion but the amount of the pollutant or pollutant parameter in the facility’s discharge is high enough that the

method detects and quantifies the level of the pollutant or pollutant parameter in the discharge; or

2. The method has the lowest ML of the analytical methods approved under 40 CFR Part 136 or required under 40 CFR chapter I, subchapter N or O for the measured pollutant or pollutant parameter.

In the case of pollutants or pollutant parameters for which there are no approved methods under 40 CFR Part 136 or otherwise required under 40 CFR chapter I, subchapter N or O, monitoring must be conducted according to a test procedure specified in this Order/permit for such pollutants or pollutant parameters. (40 CFR §§ 122.21(e)(3), 122.41(j)(4), 122.44(i)(1)(iv).)

IV. Standard Provisions – Records

- A.** Except for records of monitoring information required by this Order/permit related to the Discharger's sewage sludge use and disposal activities, which shall be retained for a period of at least five years (or longer as required by 40 CFR Part 503), the Discharger shall retain records of all monitoring information, including all calibration and maintenance records and all original strip chart recordings for continuous monitoring instrumentation, copies of all reports required by this Order/permit, and records of all data used to complete the application for this Order/permit, for a period of at least three (3) years from the date of the sample, measurement, report or application. This period may be extended by request of the Santa Ana Water Board's Executive Officer at any time. (40 CFR § 122.41(j)(2).)

B. Records of monitoring information shall include:

1. The date, exact place, and time of sampling or measurements (40 CFR § 122.41(j)(3)(i));
2. The individual(s) who performed the sampling or measurements (40 CFR § 122.41(j)(3)(ii));
3. The date(s) analyses were performed (40 CFR § 122.41(j)(3)(iii));
4. The individual(s) who performed the analyses (40 CFR § 122.41(j)(3)(iv));
5. The analytical techniques or methods used (40 CFR § 122.41(j)(3)(v)); and
6. The results of such analyses. (40 CFR § 122.41(j)(3)(vi).)

C. Claims of confidentiality for the following information will be denied (40 CFR § 122.7(b)):

1. The name and address of any permit applicant or Discharger (40 CFR § 122.7(b)(1)); and
2. Permit applications and attachments, permits and effluent data. (40 CFR § 122.7(b)(2).)

V. Standard Provisions – Reporting

A. Duty to Provide Information

The Discharger shall furnish to the Santa Ana Water Board, State Water Board, or USEPA within a reasonable time, any information which the Santa Ana Water Board, State Water Board, and/or USEPA may request to determine whether cause exists for modifying, revoking and reissuing, or terminating this Order/permit or to determine compliance with this Order/permit. Upon request, the Discharger shall also furnish to the Santa Ana Water Board, State Water Board, and/or USEPA copies of records required to be kept by this Order/permit. (40 CFR § 122.41(h); CWC § 13267, CWC § 13383.)

B. Signatory and Certification Requirements

1. All applications, reports, or information submitted to the Santa Ana Water Board, State Water Board, and/or USEPA shall be signed and certified in accordance with Standard Provisions – Reporting V.B.2, V.B.3, V.B.4, V.B.5, and V.B.6 below. (40 CFR § 122.41(k).)
2. The CWA provides that any person who knowingly makes any false statement, representation, or certification in any record or other document submitted or required to be maintained under this Order/Permit, including monitoring reports or reports of compliance or non-compliance shall, upon conviction, be punished by a fine of not more than \$10,000 per violation, or by imprisonment for not more than 6 months per violation, or by both. (40 CFR § 122.41(k)(2).)
3. For a municipality, State, federal, or other public agency all permit applications shall be signed by either a principal executive officer or ranking elected official. For purposes of this provision, a principal executive officer of a federal agency includes: (i) the chief executive officer of the agency, or (ii) a senior executive officer having responsibility for the overall operations of a principal geographic unit of the agency (e.g., Regional Administrators of USEPA). (40 CFR § 122.22(a)(3).)
4. All reports required by this Order/permit and other information requested by the Santa Ana Water Board, State Water Board, and/or USEPA shall be signed by a person described in Standard Provisions – Reporting V.B.3 above, or by a duly authorized representative of that person. A person is a duly authorized representative only if:

- a. The authorization is made in writing by a person described in Standard Provisions – Reporting V.B.3 above (40 CFR § 122.22(b)(1));
 - b. The authorization specifies either an individual or a position having responsibility for the overall operation of the regulated facility or activity such as the position of plant manager, operator of a well or a well field, superintendent, position of equivalent responsibility, or an individual or position having overall responsibility for environmental matters for the company. (A duly authorized representative may thus be either a named individual or any individual occupying a named position.) (40 CFR § 122.22(b)(2)); and
 - c. The written authorization is submitted to the Santa Ana Water Board and State Water Board. (40 CFR § 122.22(b)(3).)
5. Changes to authorization. If an authorization under Standard Provisions – Reporting V.B.4 above is no longer accurate because a different individual or position has responsibility for the overall operation of the facility, a new authorization satisfying the requirements of Standard Provisions – Reporting V.B.4 above must be submitted to the Santa Ana Water Board, State Water Board, and USEPA prior to or together with any reports, information, or applications, to be signed by an authorized representative. (40 CFR § 122.22(c).)
6. Any person signing a document under Standard Provisions – Reporting V.B.3 or V.B.4 above shall make the following certification:

“I certify under penalty of law that this document and all attachments were prepared under my direction or supervision in accordance with a system designed to assure that qualified personnel properly gather and evaluate the information submitted. Based on my inquiry of the person or persons who manage the system or those persons directly responsible for gathering the information, the information submitted is, to the best of my knowledge and belief, true, accurate, and complete. I am aware that there are significant penalties for submitting false information, including the possibility of fine and imprisonment for knowing violations.” (40 CFR § 122.22(d).)

C. Monitoring Reports

1. Monitoring results shall be reported at the intervals specified in the Monitoring and Reporting Program (Attachment E) in this Order/permit. (40 CFR § 122.22(l)(4).)
2. Monitoring results must be reported on a Discharge Monitoring Report (DMR) form or forms provided or specified by the Santa Ana Water Board or State Water Board for reporting results of monitoring of sludge use or disposal practices. As of December 21, 2016 all reports and forms submitted in compliance with this section must be submitted electronically by the Discharger to the initial recipient defined in Standard Provisions – Reporting V.J and comply with this section and 40 CFR Part 3, 40 CFR § 122.22, and 40 CFR Part 127. (40 CFR § 122.41(l)(4)(i).)

3. If the Discharger monitors any pollutant more frequently than required by this Order/permit using test procedures approved under 40 CFR Part 136, or another method required for an industry-specific waste stream under 40 CFR chapter I, subchapter N or O, or as specified in this Order/permit, the results of this monitoring shall be included in the calculation and reporting of the data submitted in the DMR or sludge reporting form specified by the Santa Ana Water Board or State Water Board. (40 CFR § 122.41(l)(4)(ii).)
4. Calculations for all limitations, which require averaging of measurements, shall utilize an arithmetic mean unless otherwise specified in this Order. (40 CFR § 122.41(l)(4)(iii).)

D. Compliance Schedules

Reports of compliance or noncompliance with, or any progress reports on, interim and final requirements contained in any compliance schedule of this Order, shall be submitted no later than 14 days following each schedule date. (40 CFR § 122.41(l)(5).)

E. Twenty-Four Hour Reporting

1. The Discharger shall report any noncompliance that may endanger health or the environment. Any information shall be provided orally within 24 hours from the time the Discharger becomes aware of the circumstances. A written submission shall also be provided within five (5) days of the time the Discharger becomes aware of the circumstances. The written submission shall contain a description of the noncompliance and its cause; the period of noncompliance, including exact dates and times, and if the noncompliance has not been corrected, the anticipated time it is expected to continue; and steps taken or planned to reduce, eliminate, and prevent reoccurrence of the noncompliance.

For noncompliance events related to combined sewer overflows, sanitary sewer overflows or bypass events, these reports must include the data described above (with the exception of time of discovery) as well as the type of event (combined sewer overflows, sanitary sewer overflows or bypass events), type of overflow structure (e.g., manhole, combined sewer overflows), discharge volumes untreated by the treatment works treating domestic sewage, types of human health and environmental impacts of the sewer overflow event, and whether the noncompliance was related to wet weather.

As of December 21, 2025, all reports related to combined sewer overflows, sanitary sewer overflows or bypass events must be submitted to the Santa Ana Water Board and must be submitted electronically by the Discharger to the initial recipient defined in Standard Provisions – Reporting V.J. The reports shall comply with 40 CFR § 3, 40 CFR § 122.22, and 40 CFR § 127. The Santa Ana Water Board may also require the Discharger to electronically submit reports not related to combined sewer

overflows, sanitary sewer overflows or bypass events under this section. (40 CFR § 122.41(l)(6)(i).)

2. The following shall be included as information that must be reported within 24 hours under this paragraph (40 CFR § 122.41(l)(6)(ii)):
 - a. Any unanticipated bypass that exceeds any effluent limitation in this Order/permit. (40 CFR § 122.41(l)(6)(ii)(A).)
 - b. Any upset that exceeds any effluent limitation in this Order/permit. (40 CFR § 122.41(l)(6)(ii)(B).)
 - c. Violation of a maximum daily discharge limitation for any of the pollutants listed by the Santa Ana Water Board in the Order/permit to be reporting within 24 hours. (See 122.44(g).) (40 CFR § 122.41(l)(6)(ii)(C).)
3. The Santa Ana Water Board may waive the above-required written report under this provision on a case-by-case basis if an oral report has been received within 24 hours. (40 CFR § 122.41(l)(6)(iii).)

F. Planned Changes

The Discharger shall give notice to the Santa Ana Water Board as soon as possible of any planned physical alterations or additions to the permitted facility. Notice is required under this provision only when (40 CFR § 122.41(l)(1)):

1. The alteration or addition to a permitted facility may meet one of the criteria for determining whether a facility is a new source in 40 CFR § 122.29(b) (40 CFR § 122.41(l)(1)(i)); or
2. The alteration or addition could significantly change the nature or increase the quantity of pollutants discharged. This notification applies to pollutants that are subject neither to effluent limitations in this Order/permit, nor to notification requirements under 40 CFR § 122.42(a)(1) (see Additional Provisions—Notification Levels VII.A). (40 CFR § 122.41(l)(1)(ii).)
3. The alteration or addition results in a significant change in the Discharger's sludge use or disposal practices, and such alteration, addition, or change may justify the application of Order/permit conditions that are different from or absent in the existing Order/permit, including notification of additional use or disposal sites not reported during the Order/permit application process or not reported pursuant to an approved land application plan. (40 CFR § 122.41(l)(1)(iii).)

G. Anticipated Noncompliance

The Discharger shall give advance notice to the Santa Ana Water Board or State Water Board of any planned changes in the permitted facility or activity that may result in noncompliance with this Order/permit's requirements. (40 CFR § 122.41(l)(2).)

H. Other Noncompliance

The Discharger shall report all instances of noncompliance not reported under Standard Provisions – Reporting V.C, V.D, and V.E above at the time monitoring reports are submitted. The reports shall contain the information listed in Standard Provision – Reporting V.E above. For noncompliance events related to combined sewer overflows, sanitary sewer overflows or bypass events, these reports shall contain the information described in Standard Provision – Reporting V.E and the applicable required data in appendix A to 40 CFR § 127. As of December 21, 2025, all reports related to combined sewer overflows, sanitary sewer overflows or bypass events submitted in compliance with this section must be submitted electronically by the Discharger to the Santa Ana Water Board or initial recipient, as defined in 40 CFR § 127.2(b), in compliance with this section and 40 CFR § 3 (including, in all cases, subpart D to 3), 122.22, and 40 CFR § 127. (40 CFR § 122.41(l)(7).)

I. Other Information

When the Discharger becomes aware that it failed to submit any relevant facts in an order/permit application, or submitted incorrect information in an order/permit application or in any report to the Santa Ana Water Board, State Water Board, or USEPA, the Discharger shall promptly submit such facts or information. (40 CFR § 122.41(l)(8).)

J. Identification of the Initial Recipient for NPDES Electronic Reporting Data

The owner, operator, or the duly authorized representative of an NPDES-regulated entity is required to electronically submit the required NPDES information (as specified in appendix A of 40 CFR part 127) to the appropriate initial recipient defined in 40 CFR section 127.2(b). USEPA will identify and publish the list of initial recipients on its website and in the Federal Register, by state and by NPDES data group [see 40 CFR section 127.2(c)]. USEPA will update and maintain this listing. (40 CFR § 122.41(l)(9).)

VI. Standard Provisions – Enforcement

- A.** The Santa Ana Water Board is authorized to enforce the terms of this permit under several provisions of the CWC, including, but not limited to, §§ 13268, 13385, 13386, and 13387.

VII. Additional Provisions – Notification Levels

A. Publicly-Owned Treatment Works (POTWs)

All POTWs shall provide adequate notice to the Santa Ana Water Board of the following (40 CFR § 122.42(b)):

1. Any new introduction of pollutants into the POTW from an indirect discharger that would be subject to sections 301 or 306 of the CWA if it were directly discharging those pollutants (40 CFR § 122.42(b)(1));
2. Any substantial change in the volume or character of pollutants being introduced into that POTW by a source introducing pollutants into the POTW at the time of adoption of the Order/permit. (40 CFR § 122.42(b)(2).); and
3. For the purpose of this paragraph, adequate notice shall include information on the quality and quantity of effluent introduced into the POTW as well as any anticipated impact of the change on the quantity or quality of effluent to be discharged from the POTW. (40 CFR § 122.42(b)(3).)

ATTACHMENT E – MONITORING AND REPORTING PROGRAM

Table of Contents

I. General Monitoring Provisions.....2
II. Monitoring Locations.....6
III. Effluent Monitoring Requirements.....6
 A. Effluent Monitoring Locations for Discharge Point 0016
IV. Reporting Requirements7
 A. General Monitoring and Reporting Requirements7
 B. Self Monitoring Reports (SMRs).....8

List of Tables

Table 1 Monitoring Station Locations.....6
Table 2 Effluent Monitoring.....7

ATTACHMENT E – MONITORING AND REPORTING PROGRAM

California Water Code (CWC) §§ 13267 and 13383 authorize the Santa Ana Regional Water Quality Control Board (Santa Ana Water Board) to require technical and monitoring reports. 40 CFR 122.48 also requires that all NPDES permits specify monitoring and reporting requirements. This Monitoring and Reporting Program establishes monitoring and reporting requirements, which implement the state and federal regulations.

I. GENERAL MONITORING PROVISIONS

A. General Monitoring Provision

1. All sampling and sample preservation shall be in accordance with the current edition of "Standard Methods for the Examination of Water and Wastewater" (American Public Health Association) or 40 CFR 136 "Guidelines Establishing Test Procedures for the Analysis of Pollutants," promulgated by the United States Environmental Protection Agency (USEPA).
2. All laboratory analyses shall be performed in accordance with test procedures under 40 CFR 136 "Guidelines Establishing Test Procedures for the Analysis of Pollutants," promulgated by the USEPA, unless otherwise specified in this Monitoring and Reporting Program. In addition, the Santa Ana Water Board and/or USEPA, at their discretion, may specify test methods that are more sensitive than those specified in 40 CFR 136.
3. Chemical, bacteriological, and bioassay analyses shall be conducted at a laboratory certified for such analyses by the California State Water Resources Control Board, Division of Drinking Water in accordance with the provision of CWC § 13176, or conducted at a laboratory certified for such analyses by the USEPA or at laboratories approved by the Santa Ana Water Board's Executive Officer.
4. Whenever the Discharger monitors any pollutant more frequently than is required by this Order, the results of this monitoring shall be included in the calculation and reporting of the data submitted in the discharge monitoring report specified by the Executive Officer.
5. In conformance with federal regulations 40 CFR 122.45(c), analyses to determine compliance with the effluent limitations for metals shall be conducted using the total recoverable method. For Chromium (VI), the dissolved method in conformance with 40 CFR 136 may be used to measure compliance with the Chromium (VI) limitation.

6. For effluent wastewater monitoring:

- a. The Discharger shall require its testing laboratory to calibrate the analytical system down to the minimum level (ML)¹ specified in Attachment “H” for priority pollutants with effluent limitations in this Order, unless an alternative minimum level is approved by the Santa Ana Water Board’s Executive Officer. When there is more than one ML value for a given substance, the Discharger shall use the ML values, and their associated analytical methods, listed in Attachment “H” that are below the effluent limitation (also refer to section III.B. of Attachment D). For analysis of priority pollutants without effluent limitations, the Discharger shall use an ML that is below the level of the most stringent applicable water quality criterion for the measured pollutant, and their associated analytical methods, listed in Attachment “H.” If no ML value is below the effluent limitation, then the lowest ML value and its associated analytical method, listed in Attachment “H” shall be used. Any internal quality control data associated with the sample must be reported when requested by the Executive Officer. The Santa Ana Water Board will reject the quantified laboratory data if quality control data is unavailable or unacceptable.
- b. The Discharger shall report the results of analytical determinations for the presence of chemical constituents in a sample using the following reporting protocols:
 - (1) Sample results greater than or equal to the reported ML shall be reported as measured by the laboratory (i.e., the measured chemical concentration in the sample).
 - (2) Sample results less than the reported ML, but greater than or equal to the laboratory’s current Method Detection Limit (MDL)², shall be reported as “Detected, but Not Quantified,” or “DNQ.” The estimated chemical concentration of the sample shall also be reported.
 - (3) Sample results not detected above the laboratory’s MDL shall be reported as “not detected” or “ND.”
- c. The Discharger shall submit to the Santa Ana Water Board reports necessary to determine compliance with effluent limitations in this Order and shall follow the chemical nomenclature and sequential order of priority pollutant constituents shown in Attachment “G” – Priority Pollutant Lists. The Discharger shall report with each sample result:

¹ *Minimum level is the concentration at which the entire analytical system must give a recognizable signal and acceptable point. The ML is the concentration in a sample that is equivalent to the concentration of the lowest calibration standard analyzed by a specific analytical procedure, assuming that all the method specified sample weights, volumes, and processing steps have been followed.*

² *MDL as defined in Attachment A of this Order.*

- (1) The reporting level achieved by the testing laboratory; and
 - (2) The laboratory's current MDL, as determined by the procedure found in 40 CFR 136.
7. For those priority pollutants without effluent limitations, the Discharger shall require its testing laboratory to quantify constituent concentrations to the lowest achievable MDL as determined by the procedure found in 40 CFR 136. In situations where the most stringent applicable receiving water objective (freshwater or human health (consumption of organisms only), as specified for that pollutant in 40 CFR 131.38³ is below the minimum level value specified in Attachment "H" and the Discharger cannot achieve an MDL value for that pollutant below the ML value, the Discharger shall submit justification why a lower MDL value cannot be achieved. Justification shall be submitted together with monthly monitoring reports.
 8. For non-priority pollutants monitoring, all analytical data shall be reported with method detection limits, as determined by the procedure found in 40 CFR 136.
 9. The Discharger shall have and implement an acceptable written quality assurance (QA) plan for laboratory analyses. Duplicate chemical analyses must be conducted on a minimum of ten percent (10%) of the samples, or at least one sample per month, whichever is greater. A similar frequency shall be maintained for analyzing spiked samples. When requested by the Santa Ana Water Board or USEPA, the Discharger will participate in the NPDES discharge monitoring report QA performance study.
 10. For every item of monitoring data where the requirements are not met, the monitoring report shall include a statement discussing the reasons for noncompliance, the actions undertaken or proposed that will bring the discharge into full compliance with requirements at the earliest time, and an estimate of the date when the Discharger will be in compliance. The Discharger shall notify the Santa Ana Water Board by letter when compliance with the time schedule has been achieved.
 11. The Discharger shall assure that records of all monitoring information are maintained and accessible for a period of at least five years (this retention period supercedes the retention period specified in Section IV.A. of Attachment D) from the date of the sample, report, or application. This period of retention shall be extended during the course of any unresolved litigation regarding this discharge or by the request of the Santa Ana Water Board at any time. Records of monitoring information shall include:
 - a. The information listed in Attachment D – IV Standard Provisions – Records, subparagraph B. of this Order;
 - b. The laboratory which performed the analyses;
 - c. The date(s) analyses were performed;

- d. The individual(s) who performed the analyses;
 - e. The modification(s) to analytical techniques or methods used;
 - f. All sampling and analytical results, including Units of measurement used;
 - g. Minimum reporting level for the analysis (minimum level);
 - h. Results less than the reporting level but above the method detection limit (MDL);
 - i. Data qualifiers and a description of the qualifiers;
 - j. Quality control test results (and a written copy of the laboratory quality assurance plan);
 - k. Dilution factors, if used; and
 - l. Sample matrix type.
 - m. All monitoring equipment calibration and maintenance records;
 - n. All original strip charts from continuous monitoring devices;
 - o. All data used to complete the application for this Order; and,
 - p. Copies of all reports required by this Order.
 - q. Electronic data and information generated by the Supervisory Control and Data Acquisition (SCADA) System.
12. The flow measurement system shall be calibrated at least once per year or more frequently, to ensure continued accuracy.
13. Monitoring and reporting shall be in accordance with the following:
- a. Samples and measurements taken for the purpose of monitoring shall be representative of the monitored activity.
 - b. The monitoring and reporting of influent, effluent, and sludge shall be done more frequently as necessary to maintain compliance with this Order and or as specified in this order.
 - c. Whenever the Discharger monitors any pollutant more frequently than is required by this Order, the results of this monitoring shall be included in the calculation and reporting of the data submitted in the discharge monitoring report specified by the Executive Officer.
 - d. A "grab" sample is defined as any individual sample collected in less than 15 minutes.
 - e. A composite sample is defined as a combination of no fewer than eight individual grab samples obtained over the specified sampling period. The volume of each individual grab sample shall be proportional to the discharge flow rate at the time of sampling. The compositing period shall equal the specific sampling period, or 24 hours, if no period is specified.
 - f. Daily samples shall be collected on each day of the week.

II. MONITORING LOCATIONS

The Discharger shall establish the following monitoring locations to demonstrate compliance with the effluent limitations, discharge specifications, and other requirements in this Order:

Table 1 Monitoring Station Locations

Discharge Point Name	Monitoring Location Name	Monitoring Location Description	Latitude and Longitude
001	M-001A	MF Effluent (Filtrate) header from MF Break Tank for subsequent transfer to UV during peak wet weather events and/or emergency events. M-001A monitors flow. M-001A is either of the two flow meters located on the 84" MFE header to the ROF chemical injection vault. M-001A is either FE/FIT-255-0430B or FE/FIT-255-0430A.	33° 41' 30" N & 117° 56' 37" W
001	M-001B	Advance treated effluent (MF/UV) to Reach 1 of Santa Ana River during peak wet weather events and/or emergency events. M-001B monitors chlorine residual and pH using continuous recorder. M-001B is also where grab samples are taken for coliform, NH3-N and any other lab analyses. M-001B is located downstream of UV and NaHSO3 addition (NaHSO3 is used as needed for dechlorination). M-001B is analyzer panel 805-CPD-0002.	33° 41' 22" N & 117° 56' 39" W
001	M-001C	Advance treated effluent (MF and cartridge filtrate) to UV for Santa Ana River discharge. M-001C monitors EC and turbidity using continuous recorder. M-001C is located downstream of MF and cartridge filters, and upstream of UV. M-001C is analyzer panel 450-CPF-0001.	33° 41' 27" N & 117° 56' 39" W

III. EFFLUENT MONITORING REQUIREMENTS

A. Effluent Monitoring Locations for Discharge Point 001

1. The Discharger shall monitor the wastewater discharged from DP 001 at Monitoring Locations M-001A, M-001B and M-001C as follows: Flow data are to be collected at M-001A. Turbidity data are to be collected at M-001C. Data on the remaining parameters are to be collected at M-001B.

Table 2 Effluent Monitoring

Parameter	Units	Sample Type	Minimum Sampling Frequency	Required Analytical Test Method and Minimum Level, units, respectively
Flow	mgd	Recorder/ Totalizer	Continuous when discharging	See Section I.A.3., above
pH	pH units	Recorder	“	“
Turbidity ⁴	NTU	“	“	“
Total Coliform Organisms ⁵	MPN per 100 ml ⁶	Grab	Daily when discharging	“
BOD ₅	mg/L	“	“	“
Total Suspended Solids	“	“	“	“
Total Chlorine Residual	“	“	“	“
Total Ammonia Nitrogen	“	“	Once per year when discharging	“
USEPA Priority Pollutants (See Attachment “G”)	“	“	“	See sections I.A.2. and I.A.3, above

IV. REPORTING REQUIREMENTS

A. General Monitoring and Reporting Requirements

1. The Discharger shall comply with all Federal Standard Provisions (Attachment D) related to monitoring, reporting, and recordkeeping.

⁴ *Turbidity analysis shall be continuous, performed by a continuous recording turbidimeter at M-001C. Compliance with the daily average operating filter effluent turbidity shall be determined by averaging the levels of recorded turbidity taken at a minimum of four-hour intervals over a 24-hour period. The results of the daily average turbidity determinations shall be reported monthly. Turbidity measurements shall be taken immediately after filtration.*

⁵ *Samples for total coliform bacteria shall be collected daily. Samples shall be taken from the disinfected effluent.*

⁶ *MPN/100mL = Most Probable Number per 100 milliliters.*

2. All analytical data shall be reported with method detection limit⁷ (MDLs) and with identification of either reporting level or limits of quantitation (LOQs) and must include quality assurance/quality control data with their reports.
3. Any internal quality control data associated with the sample must be reported when requested by the Executive Officer. The Santa Ana Water Board will reject the quantified laboratory data if quality control data is unavailable or unacceptable.
4. Discharge monitoring data shall be submitted in a format acceptable by the Santa Ana Water Board. Specific reporting format may include preprinted forms and/or electronic media. The results of all monitoring required by this Order shall be reported to the Santa Ana Water Board and shall be submitted in such a format as to allow direct comparison with the limitations and requirements of this Order.
5. The Discharger shall submit to the Santa Ana Water Board reports necessary to determine compliance with effluent limitations in this Order and shall follow the chemical nomenclature and sequential order of priority pollutant constituents shown in Attachment “G” – Priority Pollutant Lists. The Discharger shall report with each sample result:
 - a. The reporting level achieved by the testing laboratory; and
 - b. The laboratory’s current MDL, as determined by the procedure found in 40 CFR 136.
6. For every item of monitoring data where the requirements are not met, the monitoring report shall include a statement discussing the reasons for noncompliance, and of the actions undertaken or proposed which will bring the discharge into full compliance with requirements at the earliest time, and an estimate of the date when the Discharger will be in compliance. The Discharger shall notify the Santa Ana Water Board by letter when compliance with the time schedule has been achieved.

B. Self Monitoring Reports (SMRs)

1. Self-Monitoring Reports (SMRs) shall be submitted by the last day of each month and shall include all monitoring data collected during the previous month. The Discharger shall submit an SMR every month even when no discharge occurs during the monitoring period and shall certify that no discharge has taken place.
2. SMRs shall be submitted using the State Water Board’s California Integrated Water Quality System (CIWQS) Program Web site (<http://www.waterboards.ca.gov/ciwqs/index.html>). The CIWQS Web site will provide additional directions for SMR submittal in the event there will be service interruption for electronic submittal.

⁷ *The standardized test procedure to be used to determine the method detection limit (MDL) is given at Appendix B, 'Definition and Procedure for the Determination of the Method Detection Limit' of 40 CFR 136.*

3. Reporting Protocols. The Discharger shall report with each sample result the applicable reported Minimum Level (ML) and the current Method Detection Limit (MDL), as determined by the procedure in Part 136.

The Discharger shall report the results of analytical determinations for the presence of chemical constituents in a sample using the following reporting protocols:

- a. Sample results greater than or equal to the reported ML shall be reported as measured by the laboratory (i.e., the measured chemical concentration in the sample).
- b. Sample results less than the RL, but greater than or equal to the laboratory's MDL, shall be reported as "Detected, but Not Quantified," or DNQ. The estimated chemical concentration of the sample shall also be reported.

For the purposes of data collection, the laboratory shall write the estimated chemical concentration next to DNQ as well as the words "Estimated Concentration" (may be shortened to "Est. Conc."). The laboratory may, if such information is available, include numerical estimates of the data quality for the reported result. Numerical estimates of data quality may be percent accuracy (+ a percentage of the reported value), numerical ranges (low to high), or any other means considered appropriate by the laboratory.

- c. Sample results less than the laboratory's MDL shall be reported as "Not Detected," or ND.
 - d. Dischargers are to instruct laboratories to establish calibration standards so that the ML value (or its equivalent if there is differential treatment of samples relative to calibration standards) is the lowest calibration standard. At no time is the Discharger to use analytical data derived from extrapolation beyond the lowest point of the calibration curve.
4. For months when a discharge occurs, the Discharger shall attach a cover letter to the SMR. The information contained in the cover letter shall clearly identify violations of the WDRs; discuss corrective actions taken or planned; and the proposed time schedule for corrective actions. Identified violations must include a description of the requirement that was violated and a description of the violation.

ATTACHMENT F – FACT SHEET

Table of Contents

I.	Permit Information	F-3
II.	Wastewater Discharge	F-5
	A. Facility Description.....	F-5
	B. Wastewater Description.....	F-6
	C. Discharge Points and Receiving Waters.....	F-6
	D. Summary of Effluent Data.....	F-7
	E. Compliance Summary—Not Applicable.....	F-8
	F. Planned Changes – Not Applicable	F-8
III.	Applicable Plans, Policies, and Regulations.....	F-8
	A. Legal Authorities	F-8
	B. California Environmental Quality Act (CEQA).....	F-8
	C. State and Federal Regulations, Policies, and Plans	F-8
	D. Impaired Water Bodies on CWA 303(d) List – Not Applicable.....	F-10
	E. Other Plans, Polices and Regulations-Not Applicable	F-10
IV.	Rationale For Effluent Limitations and Discharge Specifications.....	F-10
	A. Discharge Prohibitions.....	F-10
	B. Technology-Based Effluent Limitations.....	F-11
	1. Scope and Authority.....	F-11
	2. Applicable Technology-Based Effluent Limitations	F-11
	C. Water Quality-Based Effluent Limitations (WQBELs) for DP 001	F-12
	1. Scope and Authority.....	F-12
	2. Applicable Beneficial Uses and Water Quality Criteria and Objectives.....	F-12
	3. Determining the Need for WQBELs	F-14
	4. WQBEL Calculations	F-18
	D. Summary of Final Effluent Limitations for DP 001	F-20
	1. Satisfaction of Anti-Backsliding Requirements.....	F-20
	2. Satisfaction of Antidegradation Policy.....	F-20
	3. Stringency of Requirements for Individual Pollutants.....	F-20
	4. Summary of Final Effluent Limitations for DP 001:	F-21
	E. Interim Effluent Limitations for DP 001 - Not Applicable	F-22
	F. Land Discharge Specifications – Not Applicable.....	F-22
	G. Reclamation Specifications – Not Applicable.....	F-22
	H. Stormwater Discharge Requirements	F-22
V.	Rationale for Receiving Water Limitations	F-22
	A. Surface Water.....	F-23
	B. Groundwater – Not Applicable	F-23
VI.	Rationale for Monitoring and Reporting Requirements.....	F-23
	A. General Monitoring Provisions.....	F-23
	B. Effluent Monitoring.....	F-23
VII.	Rationale for Provisions.....	F-23
	A. Federal Standard Provisions.....	F-23
	B. Special Provisions.....	F-24
	1. Reopener Provisions.....	F-24

2. Special Studies and Additional Monitoring Requirements – Not Applicable.....	F-24
3. Best Management Practices and Pollution Prevention	F-24
4. Construction, Operation, and Maintenance Specifications – Not Applicable.....	F-24
5. Special Provisions for Municipal Facilities - POTWs Only – Not Applicable	F-24
6. Other Special Provisions – Not Applicable.....	F-24
7. Compliance Schedules – Not Applicable	F-24
VIII. Public Participation	F-24
A. Notification of Interested Parties	F-25
B. Written Comments	F-25
C. Public Hearing	F-25
D. Reconsideration of Waste Discharge Requirements.....	F-25
E. Information and Copying.....	F-26
F. Register of Interested Persons	F-26
G. Additional Information	F-26

List of Tables

Table 1. Permit Information	F-3
Table 2. Summary of Discharge Point and Receiving Waters	F-7
Table 3. Summary of May 11, 2020 restart event data.....	F-7
Table 4. Basin Plan Beneficial Uses.....	F-9
Table 5. Summary of Technology-Based Effluent Limits for Secondary Treatment	F-12
Table 6. Applicable Basin Plan Surface Water Quality Objectives	F-13
Table 7. RPA for DP 001	F-14
Table 8. Calculated Ammonia-Nitrogen Acute Criterion	F-19
Table 9. Ammonia-Nitrogen Effluent Limits Calculation, mg/L.....	F-19
Table 10. Summary of Water Quality-Based Effluent Limits at DP 001	F-21
Table 11. Summary of Total Ammonia-Nitrogen Effluent Limits at DP 001	F-21

ATTACHMENT F – FACT SHEET

As described in Section II of this Order, this Fact Sheet includes the legal requirements and technical rationale that serve as the basis for the requirements of this Order.

This Order has been prepared under a standardized format to accommodate a broad range of discharge requirements for Dischargers in California. Only those sections or subsections of this Order that are specifically identified as “not applicable” have been determined not to apply to this Discharger. Sections or subsections of this Order not specifically identified as “not applicable” are fully applicable to this Discharger.

I. PERMIT INFORMATION

The following table summarizes administrative information related to the Discharger.

Table 1. Permit Information

WDID	8 303545001
Discharger	Orange County Water District
Mailing Address	P.O. Box 8300, Fountain Valley, CA 92728-8300
Discharger Contact	Jason Dadakis, Executive Director of Water Quality and Technical Resources
Name of Facility	Groundwater Replenishment System (GWRS) – Advanced Water Purification Facility (AWPF)
Facility Address	18700 Ward Street, Fountain Valley, CA 92708
Billing Address	P.O. Box 8300, Fountain Valley, CA 92728-8300
Type of Facility	Water Recycling Facility (Tertiary Treatment only)
Major or Minor Facility	Minor
Facility Permitted Flow – Tertiary treated	100 million gallons per day (mgd)
Watershed	Santa Ana River Watershed
Receiving Water	Reach 1, Santa Ana River
Receiving Water Type	Inland Surface Water

Orange County Water District (hereinafter Discharger or OCWD) owns and operates the Advanced Water Purification Facility (hereinafter Facility or AWPF) that is part of the OCWD’s Groundwater Replenishment System (GWRS). The GWRS is a joint project by OCWD and the Orange County Sanitation District (OC San). The GWRS consists of five major components: AWPF, Talbert Gap Seawater Intrusion Barrier (Talbert Barrier), Mid-Basin Injection Project (MBI), Kraemer/Miller/Miraloma/La Palma Spreading Basins (Spreading Basins) and two non-potable water reuse sites, with additional reuse sites planned.

For the purposes of this Order, references to the “discharger” or “permittee” in applicable federal and State laws, regulations, plans, or policy are held to be equivalent to references to the Discharger herein.

The GWRS is a joint project by OCWD and Orange County Sanitation District (OC San) and is a water supply project that supplements existing water supplies by providing a new, reliable, high-quality source of water to recharge the Orange Groundwater Management Zone (OGMZ) and protect the OGMZ from further degradation due to seawater intrusion. In addition, OC San relies upon the AWPf to provide peak wet weather flow relief for OC San’s ocean outfall. The GWRS System is located in central Orange County and extends from Fountain Valley and Huntington Beach near the coast to Santa Ana, Orange, and Anaheim, generally near the Santa Ana River. Secondary treated effluent from OC San’s Reclamation Plant No. 1 (RP-1) is sent to the AWPf, where it is advance treated to produce full advanced treated (FAT) recycled water that meets the California Code of Regulations (CCR) Title 22 requirements for groundwater recharge (indirect potable reuse). Also, the water quality of the FAT recycled water produced at the AWPf meets and exceeds CCR Title 22 requirement for recycled water produced for non-potable reuse.

On December 12, 2014, the Santa Ana Regional Water Quality Control Board (Hereinafter the Santa Ana Water Board) issued Order No. R8-2014-0069 and National Pollutant Discharge Elimination System (NPDES) Permit No. CA8000408 to the OCWD to discharge tertiary treated and disinfected wastewater from its AWPf to Reach 1 of the Santa Ana River (SAR), under emergency conditions. Order No. R8-2014-0069 expired on December 31, 2019 and was not administratively extended, or not continued beyond its expiration date, because the Discharger did not submit a timely application, Report of Waste Discharge (ROWD), for a new permit 180 days before the expiration date of Order No. R8-2014-0069 as required pursuant to 40 CFR 122.6(a). Therefore, the Discharger has not been authorized to discharge since Order No. R8-2014-0069 expired. However, the Discharger has never discharged to Reach 1 of the SAR from this Facility. Although the Facility normally produces FAT recycled water for indirect potable and non-potable reuse, this Order re-authorizes and regulates the discharge of tertiary treated and disinfected wastewater to Reach 1 of the SAR from the Facility, under emergency conditions, to provide peak wet weather flow relief for OC San’s ocean outfall. The Santa Ana Water Board regulates the reuse of FAT recycled water for the Talbert Barrier, MBI, and the Spreading Basins under Order No. R8-2004-0002, as amended, and the two non-potable recycled water reuse sites under Order No. R8-2021-0003.

The Discharger filed a Report of Waste Discharge and submitted an application for re-issuance of its NPDES permit on December 23, 2019. A site visit was conducted on December 10, 2022, to observe operations and collect additional data to develop permit limitations and requirements for waste discharge. The application was deemed complete on January 10, 2022. Attachment B provides a map of the area around the Facility. Attachment C provides a flow schematic of the Facility.

Regulations at 40 CFR 122.46 limit the duration of NPDES permits to a fixed term not to exceed five years. Accordingly, Table 3 of this Order limits the duration of the discharge authorization. However, pursuant to CCR’s Title 23, section 2235.4, the terms and

conditions of an expired permit are automatically continued pending reissuance of the permit if the Discharger complies with all federal NPDES requirements for continuation of expired permits (See also 40 CFR § 122.6(d)).

II. WASTEWATER DISCHARGE

A. Facility Description

The AWPf is located at 18700 Ward Street, Fountain Valley in Orange County. It includes treatment processes and pumping stations. The AWPf treatment design capacity is currently 100 mgd for FAT recycled water production. The production of FAT recycled water started in January 2008. The Facility is undergoing expansion for a treatment design capacity of 130 mgd by early 2023. The facility expansion will include accepting a new influent source, secondary treated effluent from OC San's Treatment Plant No. 2 (TP-2).

The advanced treatment processes are as follows:

- a. Fine Screening: Secondary treated wastewater from OC San's RP-1 is strained, or passed through rotating band fine-mesh screens, and chlorinated (as needed) prior to microfiltration. Screenings are dewatered and returned to OC San for disposal.
- b. Microfiltration: Screened secondary effluent flows via gravity to 26 in-basin microfiltration (MF) cells containing submerged racks of hollow fiber membranes with a maximum pore size of 0.2 micron. Sodium hypochlorite is added as needed to the MF feed to form a low level (3-5 mg/L) of chloramine to reduce/prevent fouling of the MF membranes. The waste backwash is returned to OC San for treatment.
- c. Reverse Osmosis. The RO process will be bypassed when AWPf effluent is discharged to the Santa Ana River.
- d. Advanced Oxidation/UV Disinfection: The advanced oxidation/disinfection process (AOP) consists of two steps: hydrogen peroxide addition and ultraviolet (UV) light treatment. UV irradiation is used for disinfection and reduction of light-sensitive contaminants. Hydrogen peroxide exposed to UV irradiation produces hydroxyl radicals that result in advanced oxidation to destroy UV-resistant contaminants. For direct discharge to the SAR, only UV treatment will be used. The nominal reliable capacity of the UV system is 100 mgd.
- e. Decarbonation and Lime Stabilization Process: This treatment process will be bypassed when AWPf effluent is discharged to the SAR.
- f. Dechlorination and pH adjustment: After UV disinfection and prior to discharge to the SAR, the effluent stream may still contain some chloramines. Sodium bisulfate will be added for dechlorination, if needed.

Approximately, up to 33 mgd of membrane backwash, brine and start-up waste streams are returned to OC San's RP-1 and will not be discharged to the SAR, even under emergency conditions or during discharge system testing periods.

B. Wastewater Description

This Order regulates discharges from the AWPf into Reach 1 of the SAR under emergency conditions to provide flow relief when peak wastewater flows at OC San approach the capacity of the 120" diameter 5-mile long ocean outfall and, thereby, threaten the integrity of the outfall and the wastewater treatment facilities, or when the OC San ocean outfall is being repaired.

High wastewater flows approaching the maximum capacity of the OC San's outfall may occur, typically caused by peak wet weather storm events. It is anticipated that storm events creating peak wastewater flows may occur infrequently and may last approximately 12 hours each, and may occur about once every three years, based on flow projections for the year 2020. However, no such events have occurred during the past thirteen years. During such events, the SAR will likely convey storm water to the ocean and provide dilution of the AWPf discharge. The amount of flow in the SAR is likely to be highly variable depending on the location, duration and intensity of the storm and the performance of upstream flood control facilities.

Under emergency conditions, including peak wastewater flow events at OC San that approach the maximum capacity of OC San's ocean outfall, secondary treated wastewater flows from OC San's RP-1 will be diverted to the AWPf for further treatment and discharge to Reach 1 of the SAR. During these peak wastewater flow conditions, the AWPf will provide up to 100 mgd of flow relief for OC San. The AWPf will treat secondary effluent flows of up to 133 mgd from RP-1 using microfiltration (MF) and ultraviolet light (UV) disinfection (bypassing reverse osmosis (RO)), followed by post-treatment chemical addition as needed for pH adjustment. The microfiltered, disinfected tertiary effluent will be dechlorinated (as needed) prior to being discharged to Reach 1 of the SAR via a separate pipeline that will terminate at the SAR channel at Garfield Avenue in Fountain Valley (DP 001). Reach 1 of the SAR is tributary to the Pacific Ocean (about 4 miles from discharge point). Both the SAR and the Pacific Ocean are waters of the United States.

Since the AWPf began operating, there has never been a direct discharge from the Facility to the SAR.

C. Discharge Points and Receiving Waters

1. Discharge Point

Up to 100 mgd of tertiary treated wastewater will be discharged to the Santa Ana River via DP 001. The DP 001 is located about four miles upstream of the mouth of the SAR at the Pacific Ocean.

2. Receiving Water

Treated wastewater from the AWPf will be discharged to Reach 1 of the SAR and then to the Pacific Ocean, which are waters of the United States. The Pacific Ocean is approximately four miles away from the discharge point.

Table 2. Summary of Discharge Point and Receiving Waters

Discharge Point	Latitude	Longitude	Description and Receiving Waters	Flow & Frequency
001	33°41'13" N	117°56'22" W	Reach 1 of the Santa Ana River.	Up to 100 mgd

D. Summary of Effluent Data

On May 11, 2020 a special scheduled AWPf's restart event was conducted. The Facility was temporarily operated in SAR Discharge treatment mode and the discharge was directed to the OC San's Pacific Ocean outfall. Effluent monitoring data was collected during this event to determine the anticipated quality of the wastewater discharged from the AWPf during emergency conditions. A summary of that data is listed in the following table.

Table 3. Summary of May 11, 2020 restart event data

Parameter	Units	Result
pH	SU	7.2
Biochemical Oxygen Demand	mg/L	<2
Field Dissolved Oxygen	mg/L	4.65
Field Temperature	C	25.0
Temperature (Laboratory)	C	21.4
Ammonia Nitrogen	mg/L	1.4
Nitrate	mg/L	50
Nitrate + Nitrite Nitrogen	mg/L	11.65
Nitrate Nitrogen	mg/L	11.3
Nitrite	mg/L	1.14
Nitrite Nitrogen	mg/L	0.347
Total Dissolved Solids	mg/L	932
Total Hardness (as CaCO3)	mg/L	335
Selenium	µg/L	1.3
Copper	µg/L	5.5
Nickel	µg/L	3.4
Zinc	µg/L	9.1
Bromodichloromethane	µg/L	4.8
Chloride	mg/L	219
Chloroform	µg/L	9.1
n-Nitrosodimethylamine	ng/L	5.1

Table 3. Summary of May 11, 2020 restart event data

Parameter	Units	Result
Phosphate Phosphorus (orthophosphate)	mg/L	0.51

Since no emergency discharges have taken place from the AWPf, effluent monitoring data from the May 11, 2020 discharge simulation event, to the OC San’s ocean outfall system, was used in the reasonable potential analysis. (see Section IV.C.3., below)

E. Compliance Summary—Not Applicable

F. Planned Changes – Not Applicable

III. APPLICABLE PLANS, POLICIES, AND REGULATIONS

The requirements contained in the Order are based on the requirements and authorities described in this section.

A. Legal Authorities

This Order is issued pursuant to the federal Clean Water Act’s (CWA) § 402 and implements regulations adopted by the U.S. Environmental Protection Agency (USEPA) and the California Water Code’s (CWC), Chapter 5.5, Division 7 (commencing with § 13370). It shall serve as a NPDES permit for point source discharges from this Facility to surface waters.

B. California Environmental Quality Act (CEQA)

Under CWC § 13389, this action to adopt an NPDES permit is exempt from the provisions of CEQA, Public Resources Code section 21000 et seq. (*County of Los Angeles v. California State Water Resources Control Board* (2006) 143 Cal.App.4th 985, mod. (Nov. 6, 2006, B184034) 50 Cal.Rptr.3d 619, 632-636.)

C. State and Federal Regulations, Policies, and Plans

1. Water Quality Control Plans. The Santa Ana Water Board adopted an updated Water Quality Control Plan for the Santa Ana Basin (hereinafter Basin Plan) that became effective on January 24, 1995. The Basin Plan designates beneficial uses, establishes water quality objectives, and contains implementation programs and policies to achieve those objectives for all waters addressed through the plan. In addition, State Water Resources Control Board (State Water Board) Resolution No. 88-63 (Sources of Drinking Water Policy) requires that, with certain exceptions, the Santa Ana Water Board assign the municipal and domestic water supply use to water bodies. Based on the exception criteria specified in Resolution No. 88-63, the Santa Ana Water Board excepted Reach 5 (starting from Orange Avenue in the City of Redlands) of the Santa Ana River and downstream reaches, including Reach 1, from the municipal and domestic supply beneficial use.

The designated beneficial uses of receiving waters affected by the discharge from the Facility are as follows:

Table 4. Basin Plan Beneficial Uses

Discharge Point	Receiving Water Name	Beneficial Use(s)
001	Reach 1 of Santa Ana River	<u>Present or Potential:</u> Water contact recreation, non-contact water recreation, and intermittent beneficial uses in warm freshwater habitat and wildlife habitat. Excepted from Municipal and Domestic Supply.

Requirements of this Order implement the Basin Plan.

- 2. National Toxics Rule (NTR) and California Toxics Rule (CTR).** USEPA adopted the NTR on December 22, 1992, and later amended it on May 4, 1995 and November 9, 1999. About forty criteria in the NTR applied in California. On May 18, 2000, USEPA adopted the CTR. The CTR promulgated new toxics criteria for California and, in addition, incorporated the previously adopted NTR criteria that were applicable in the state. The CTR was amended on February 13, 2001. These rules contain water quality criteria for priority pollutants.
- 3. State Implementation Policy.** On March 2, 2000, the State Water Board adopted the *Policy for Implementation of Toxics Standards for Inland Surface Waters, Enclosed Bays, and Estuaries of California* (State Implementation Policy or SIP). The SIP became effective on April 28, 2000 with respect to the priority pollutant criteria promulgated for California by the USEPA through the NTR and to the priority pollutant objectives established by the Santa Ana Water Board in the Basin Plan. The SIP became effective on May 18, 2000 with respect to the priority pollutant criteria promulgated by the USEPA through the CTR. The State Water Board adopted amendments to the SIP on February 24, 2005 that became effective on July 13, 2005. The SIP establishes implementation provisions for priority pollutant criteria and objectives and provisions for chronic toxicity control. Requirements of this Order implement the SIP.
- 4. Alaska Rule.** On March 30, 2000, USEPA revised its regulation that specifies when new and revised state and tribal water quality standards (WQS) become effective for CWA purposes (40 C.F.R. § 131.21, 65 Fed. Reg. 24641 (April 27, 2000)). Under the revised regulation (also known as the Alaska rule), new and revised standards submitted to USEPA after May 30, 2000, must be approved by USEPA before being used for CWA purposes. The final rule also provides that standards already in effect and submitted to USEPA by May 30, 2000, may be used for CWA purposes, whether or not approved by USEPA.
- 5. Antidegradation Policy.** 40 CFR 131.12 requires that the state water quality standards include an antidegradation policy consistent with the federal policy. The

State Water Board established California's antidegradation policy in State Water Board Resolution No. 68-16. Resolution No. 68-16 incorporates the federal antidegradation policy where the federal policy applies under federal law. Resolution No. 68-16 requires that existing water quality be maintained unless degradation is justified based on specific findings. The Santa Ana Water Board's Basin Plan implements, and incorporates by reference, both the State and federal antidegradation policies. The permitted discharge must be consistent with the antidegradation provision of 40 CFR 131.12 and State Water Board Resolution No. 68-16. Because of the limited expected frequency and duration of the discharge, the discharge will not result in a significant lowering of water quality. Therefore, the discharge is in conformance with the antidegradation policy.

- 6. Anti-Backsliding Requirements.** §§ 402(o)(2) and 303(d)(4) of the CWA and 40 CFR 122.44(l) prohibit backsliding in NPDES permits. These anti-backsliding provisions require that effluent limitations in a reissued permit must be as stringent as those in the previous permit, with some exceptions in which limitations may be relaxed. All effluent limitations in this Order are at least as stringent as the effluent limitations in the previous Order.
- 7. Monitoring and Reporting Requirements.** Sections 13267 and 13383 of the CWC authorize the Santa Ana Water Board to require technical and monitoring reports. In addition, 40 CFR 122.48 requires that all NPDES permits specify requirements for recording and reporting monitoring results. The Monitoring and Reporting Program (Attachment E) establishes monitoring and reporting requirements to implement federal and State requirements.

D. Impaired Water Bodies on CWA 303(d) List – Not Applicable

E. Other Plans, Policies and Regulations-Not Applicable

IV. RATIONALE FOR EFFLUENT LIMITATIONS AND DISCHARGE SPECIFICATIONS

The CWA requires point source Dischargers to control the amount of conventional, non-conventional, and toxic pollutants that are discharged into the waters of the United States. The control of pollutants discharged is established through effluent limitations and other requirements in NPDES permits. There are two principal bases for effluent limitations in the 40 CFR 122.44(a) requires that permits include applicable technology-based limitations and standards; and 40 CFR 122.44(d) requires that permits include water quality-based effluent limitations to attain and maintain applicable numeric and narrative water quality criteria to protect the beneficial uses of the receiving water

A. Discharge Prohibitions

The discharge prohibitions are based on the Federal Clean Water Act, Basin Plan, State Water Board's plans and policies, U.S. Environmental Protection Agency guidance and regulations.

B. Technology-Based Effluent Limitations

1. Scope and Authority

§ 301(b) of the CWA and implementing USEPA permit regulations at 40 CFR 122.44 require that permits include conditions meeting applicable technology-based requirements at a minimum, and any more stringent effluent limitations necessary to meet applicable water quality standards. The discharge authorized by this Order meet minimum federal technology-based requirements based on Secondary Treatment Standards at 40 CFR 133 and/or Best Professional Judgment (BPJ) in accordance with 40 CFR 125.3.

Regulations promulgated in 40 CFR 125.3(a)(1) require technology-based effluent limitations for municipal dischargers to be placed in waste discharge requirements based on Secondary Treatment Standards or Equivalent to Secondary Treatment Standards.

The Federal Water Pollution Control Act Amendments of 1972 (PL 92-500) established the minimum performance requirements for POTWs [defined in § 304(d)(1)]. § 301(b)(1)(B) of that Act requires that such treatment works must, as a minimum, meet effluent limitations based on secondary treatment as defined by the USEPA Administrator.

Based on this statutory requirement, USEPA developed secondary treatment regulations, which are specified in 40 CFR Part 133. These technology-based regulations apply to all municipal wastewater treatment plants and identify the minimum level of effluent quality attainable by secondary treatment in terms of biochemical oxygen demand (BOD₅), total suspended solids (TSS), and pH.

2. Applicable Technology-Based Effluent Limitations

This Facility meets the technology-based regulations for the minimum level of effluent quality attainable by secondary treatment in terms of BOD₅, total suspended solids and removal rate as summarized in the Table 5 below. Secondary treated wastewater that meets the limitations specified in Table 5, below, will be diverted to the AWPf from OC San's RP-1 and subjected to additional treatment prior to re-use or, under emergency conditions, discharge to the SAR (pursuant to the requirements of this Order.)

Table 5. Summary of Technology-Based Effluent Limits for Secondary Treatment

Constituent	Average Weekly (mg/L)	Average Monthly (mg/L)	Average Monthly Removal Rate %
Biochemical Oxygen Demand, 5-day 20°C	45	30	85
Total Suspended Solids	45	30	85

C. Water Quality-Based Effluent Limitations (WQBELs) for DP 001

1. Scope and Authority

§ 301(b) of the CWA and 40 CFR 122.44(d) require that permits include limitations more stringent than applicable federal technology-based requirements where necessary to achieve applicable water quality standards.

40 CFR 122.44(d)(1)(i) mandates that permits include effluent limitations for all pollutants that are or may be discharged at levels that have the reasonable potential to cause or contribute to an exceedance of a water quality standard, including numeric and narrative objectives within a standard. Where reasonable potential has been established for a pollutant, but there is no numeric criterion or objective for the pollutant, water quality-based effluent limitations (WQBELs) must be established using: (1) USEPA criteria guidance under CWA § 304(a), supplemented where necessary by other relevant information; (2) an indicator parameter for the pollutant of concern; or (3) a calculated numeric water quality criterion, such as a proposed state criterion or policy interpreting the state’s narrative criterion, supplemented with other relevant information, as provided in 40 CFR 122.44(d)(1)(vi).

The process for determining reasonable potential and calculating WQBELs when necessary is intended to protect the designated uses of the receiving water as specified in the Basin Plan, and achieve applicable water quality objectives and criteria that are contained in other state plans and policies, or any applicable water quality criteria contained in the CTR and NTR, and in the California Ocean Plan.

2. Applicable Beneficial Uses and Water Quality Criteria and Objectives

- a. The Basin Plan** specifies narrative and numeric water quality objectives (WQOs) applicable to surface water as follows.

Table 6. Applicable Basin Plan Surface Water Quality Objectives

Constituents	Basis for Limitations
Chlorine Residual	Wastewater disinfection with chlorine usually produces a chlorine residual. Chlorine and its reaction products are toxic to aquatic life. To protect aquatic life, the chlorine residual in wastewater discharged to inland surface waters shall not exceed 0.1 mg/L.
pH	The pH of inland surface water shall not be raised above 8.5 or depressed below 6.5 as a result of controllable water quality factors.

b. NTR, CTR and SIP. The National Toxics Rule, California Toxics Rule (CTR) and State Implementation Policy specify numeric objectives for toxic substances and the procedures whereby these objectives are to be implemented. The procedures include those used to conduct reasonable potential analysis to determine the need for effluent limitations for priority and non-priority pollutants.

c. Requirement to meet 2.2 total coliform bacteria limit in the effluent

CCR’s Title 22, Chapter 3, Article 3, § 60305, "Use of Recycled water for impoundments" specifies that recycled water used as a source of supply in a nonrestricted recreational impoundment shall be at all times an adequately disinfected, oxidized, coagulated, clarified, filtered wastewater (tertiary treated). The degree of treatment specified represents an approximately 5-log reduction in the virus content of the water. The California State Water Resources Control Board’s Division of Drinking Water (DDW) has determined that this degree of virus removal is necessary to protect the health of people using these impoundments for water contact recreation. The DDW has developed wastewater disinfection guidelines ("Wastewater Disinfection for Health Protection", Department of Health Services, Sanitary Engineering Branch, February 1987) for discharges of wastewater to surface waters where water contact recreation (REC-1) is a beneficial use. The disinfection guidelines recommend the same treatment requirements for wastewater discharges to REC-1 waters as those stipulated in Title 22 for supply of recycled water to nonrestricted recreational impoundments, since the public health risks under both scenarios are analogous. The disinfection guidelines are based on sound science and are widely used as guidance to assure public health and beneficial use protection.

Reach 1 of the SAR is not a “nonrestricted recreational impoundment”, nor is “recycled water¹” proposed to be discharged to the River pursuant to the definitions in Title 22. However, to protect the water contact recreation beneficial

¹ As defined in the Reclamation Criteria, recycled water means water which, as a result of treatment of domestic wastewater, is suitable for a direct beneficial use or a controlled use that would not otherwise occur.

use and to prevent nuisance and health risk, it is necessary and appropriate to require the same degree of treatment for wastewater discharges to the River as would be required for the use of recycled water in a nonrestricted recreational impoundment. Thus, this Order specifies requirements based on tertiary or equivalent treatment.

3. Determining the Need for WQBELs

In accordance with Section 1.3 of the SIP, the Santa Ana Water Board conducted a reasonable potential analysis (RPA) for each priority pollutant with an applicable criterion or objective to determine if a WQBEL is required in the Order. The Santa Ana Water Board analyzed effluent data to determine if a pollutant in a discharge has the reasonable potential to cause or contribute to an excursion above a state water quality standard. For all parameters that have the reasonable potential to cause or contribute to an excursion above a water quality standard, numeric WQBELs are required. The RPA considers criteria from the CTR, and when applicable, water quality objectives specified in the Basin Plan.

Currently, AWPf is operating for groundwater recharge purposes only and since the start of its operations, in January 2008, there has been no discharge from the Facility to Reach 1 of the SAR. Therefore, no monitoring data is yet available from this Facility. However, the Discharger conducted on May 11, 2020 a special scheduled GWRS plant restart event. The Facility was temporarily operated in the SAR Discharge treatment mode and the discharge was directed to the OC San's outfall. Effluent data was collected during this event to simulate the anticipated quality of the tertiary treated wastewater that would be discharged from the AWPf during emergency conditions.

The RPA was performed for the pollutants for which effluent data were available. By reviewing the data provided by the Discharger, chlorine residual and ammonia-N were determined to have reasonable potential to cause an excursion above applicable pollutant criteria or objectives. Consequently, effluent limitations for chlorine residual and ammonia-N are again included in this Order. There's was no reasonable potential determined for selenium and free cyanide and effluent limits for these pollutants were not included in this Order pursuant to anti-backsliding considerations (see section IV.D.1. of this Fact Sheet, below).

Table 7. RPA for DP 001

Parameter	unit	Effluent MEC	Selected Criteria ¹	Source of Criteria	Is Effluent Limit Required?
Chlorine, Residual	mg/L	<0.1	0.1	BPJ ² /BP-WQO ³	Yes ⁴
Ammonia-N	mg/L	1.4	29.5 ⁵	BPJ/NTR ⁶	Yes ⁷
Antimony	µg/L	<1	4300	CTR-HH ⁸	No
Arsenic	µg/L	<1	150	CTR-CCC ⁹	No

Table 7. RPA for DP 001

Parameter	unit	Effluent MEC	Selected Criteria ¹	Source of Criteria	Is Effluent Limit Required?
Beryllium	µg/L	<1	NC ¹⁰	--	No
Cadmium	µg/L	<1	6.36	CTR-CCC	No
Chromium (III)	µg/L	¹¹	557	CTR-CCC	No
Chromium (VI)	µg/L	<0.2	11.43	CTR-CCC	No
Copper	µg/L	5.5	26.21	CTR-CCC	No
Lead	µg/L	<1	14.82	CTR-CCC	No
Mercury	µg/L	<1	0.051	CTR-HH	No
Nickel	µg/L	3.4	147	CTR-CCC	No
Selenium	µg/L	1.3	5.0	CTR-CCC	No
Silver	µg/L	<1	32.47	CTR-CMC ¹²	No
Thallium	µg/L	<1	6.3	CTR-HH	No
Zinc	µg/L	9.1	106	CTR-CMC	No
Cyanide	µg/L	<5	5.2	CTR-CCC	No
2,3,7,8-TCDD	µg/L	<4.8E-6	1.4E-08	CTR-HH	No
Acrolein	µg/L	<5	780	CTR-HH	No
Acrylonitrile	µg/L	<5	0.66	CTR-HH	No
Benzene	µg/L	<0.5	71	CTR-HH	No
Bromoform	µg/L	<0.5	360	CTR-HH	No
Carbon Tetrachloride	µg/L	<0.5	4.4	CTR-HH	No
Chlorobenzene	µg/L	<0.5	21000	CTR-HH	No
Chlorodibromomethane	µg/L	1.5	34	CTR-HH	No
Chloroethane	µg/L	<0.5	NC	--	No
2-Chloroethyl Vinyl Ether	µg/L	<1	NC	--	No
Chloroform	µg/L	9.1	NC	--	No
Dichlorobromomethane	µg/L	4.8	46	CTR-HH	No
1,1-Dichloroethane	µg/L	<0.5	NC	--	No
1,2-Dichloroethane	µg/L	<0.5	99	CTR-HH	No
1,1-Dichloroethylene	µg/L	<0.5	3.2	CTR-HH	No
1,2-Dichloropropane	µg/L	<0.5	39	CTR-HH	No
1,3-Dichloropropylene	µg/L	<0.5	1,700	CTR-HH	No
Ethylbenzene	µg/L	<0.5	29,000	CTR-HH	No
Methyl Bromide	µg/L	<0.5	4,000	CTR-HH	No
Methyl chloride	µg/L	<0.5	NC	--	No
Methylene Chloride	µg/L	<0.5	1,600	CTR-HH	No
1,1,2,2-Tetrachloroethane	µg/L	<0.5	11	CTR-HH	No
Tetrachloroethylene	µg/L	<0.5	8.85	CTR-HH	No
Toluene	µg/L	<0.5	200,000	CTR-HH	No

Table 7. RPA for DP 001

Parameter	unit	Effluent MEC	Selected Criteria ¹	Source of Criteria	Is Effluent Limit Required?
1,2-Trans-Dichloroethylene	µg/L	<0.5	140,000	CTR-HH	No
1,1,1-Trichloroethane	µg/L	<0.5	NC	--	No
1,1,2-Trichloroethane	µg/L	<0.5	42	CTR-HH	No
Trichloroethylene	µg/L	<0.5	81	CTR-HH	No
Vinyl Chloride	µg/L	<0.5	525	CTR-HH	No
2-Chlorophenol	µg/L	<1	400	CTR-HH	No
2,4-Dichlorophenol	µg/L	<1	790	CTR-HH	No
2,4-Dimethylphenol	µg/L	<1	2300	CTR-HH	No
2-Methyl-4,6-Dinitrophenol	µg/L	<5	765	CTR-HH	No
2,4-Dinitrophenol	µg/L	<10	14000	CTR-HH	No
2-Nitrophenol	µg/L	<1	NC	--	No
4-Nitrophenol	µg/L	<5	NC	--	No
3-Methyl-4-Chlorophenol	µg/L	<1	NC	--	No
Pentachlorophenol	µg/L	<1	8.2	CTR-HH	No
Phenol	µg/L	<1	4,600,000	CTR-HH	No
2, 4, 6 – Trichlorophenol	µg/L	<1	6.5	CTR-HH	No
Acenaphthene	µg/L	<0.1	2700	CTR-HH	No
Acenaphthylene	µg/L	<0.1	NC	--	No
Anthracene	µg/L	<0.1	110,000	CTR-HH	No
Benzidine	µg/L	<10	0.00054	CTR-HH	No
Benzo (a) Anthracene	µg/L	<0.1	0.049	CTR-HH	No
Benzo (a) Pyrene	µg/L	<0.1	0.049	CTR-HH	No
Benzo (b) Fluoranthene	µg/L	<0.1	0.049	CTR-HH	No
Benzo (g,h,i) Perylene	µg/L	<0.1	NC	--	No
Benzo (k) Fluoranthene	µg/L	<0.1	0.049	CTR-HH	No
Bis (2-Chloroethoxy) Methane	µg/L	<1	NC	--	No
Bis (2-Chloroethyl) Ether	µg/L	<1	1.4	CTR-HH	No
Bis (2-Chloroisopropyl) Ether	µg/L	<1	170,000	CTR-HH	No
Bis (2-Ethylhexyl) Phthalate	µg/L	<5	5.9	CTR-HH	No
4-Bromophenyl Phenyl Ether	µg/L	<1	NC	--	No
Butylbenzyl Phthalate	µg/L	<1	5,200	CTR-HH	No
2-Chloronaphthalene	µg/L	<1	4,300	CTR-HH	No

Table 7. RPA for DP 001

Parameter	unit	Effluent MEC	Selected Criteria ¹	Source of Criteria	Is Effluent Limit Required?
4-Chlorophenyl Phenyl Ether	µg/L	<1	NC	--	No
Chrysene	µg/L	<0.1	0.049	CTR-HH	No
Dibenzo (a,h) Anthracene	µg/L	<0.1	0.049	CTR-HH	No
1,2-Dichlorobenzene	µg/L	<0.5	17,000	CTR-HH	No
1,3-Dichlorobenzene	µg/L	<0.5	2,600	CTR-HH	No
1,4-Dichlorobenzene	µg/L	<0.5	2,600	CTR-HH	No
3,3'- Dichlorobenzidine	µg/L	<5	0.077	CTR-HH	No
Diethyl Phthalate	µg/L	<1	120,000	CTR-HH	No
Dimethyl Phthalate	µg/L	<1	2,900,000	CTR-HH	No
Di-n-Butyl Phthalate	µg/L	<1	12,000	CTR-HH	No
2,4-Dinitrotoluene	µg/L	<0.1	9.1	CTR-HH	No
2,6-Dinitrotoluene	µg/L	<0.1	NC	--	No
Di-n-Octyl Phthalate	µg/L	<1	NC	--	No
1,2-DiphenylHydrazine	µg/L	<25	0.54	CTR-HH	No
Fluoranthene	µg/L	<0.1	370	CTR-HH	No
Fluorene	µg/L	<0.1	14,000	CTR-HH	No
Hexachlorobenzene	µg/L	<0.05	0.00077	CTR-HH	No
Hexachlorobutadiene	µg/L	<0.5	50	CTR-HH	No
Hexachlorocyclopentadiene	µg/L	<0.05	17,000	CTR-HH	No
Hexachloroethane	µg/L	<1	8.9	CTR-HH	No
Indeno (1,2,3-cd) Pyrene	µg/L	<0.1	0.049	CTR-HH	No
Isophorone	µg/L	<0.1	600	CTR-HH	No
Naphthalene	µg/L	<0.1	NC	--	No
Nitrobenzene	µg/L	<1	1,900	CTR-HH	No
N-Nitrosodimethylamine	µg/L	0.0051	8.1	CTR-HH	No
N-Nitrosodi-N-Propylamine	µg/L	<0.002	1.4	CTR-HH	No
N-Nitrosodiphenylamine	µg/L	<1	16	CTR-HH	No
Phenanthrene	µg/L	<0.1	NC	--	No
Pyrene	µg/L	<0.1	11,000	CTR-HH	No
1,2,4-Trichlorobenzene	µg/L	<0.5	NC	--	No
Aldrin	µg/L	<0.01	0.00014	CTR-HH	No
Alpha BHC	µg/L	<0.01	0.013	CTR-HH	No
Beta BHC	µg/L	<0.01	0.046	CTR-HH	No
Delta BHC	µg/L	<0.01	NC	--	No
Gamma BHC	µg/L	<0.01	0.063	CTR-HH	No

Table 7. RPA for DP 001

Parameter	unit	Effluent MEC	Selected Criteria ¹	Source of Criteria	Is Effluent Limit Required?
Chlordane	µg/L	<0.1	0.00059	CTR-HH	No
4,4'-DDT	µg/L	<0.01	0.00059	CTR-HH	No
4,4'-DDE	µg/L	<0.01	0.00059	CTR-HH	No
4,4'-DDD	µg/L	<0.01	0.00084	CTR-HH	No
Dieldrin	µg/L	<0.01	0.00014	CTR-HH	No
Alpha Endosulfan	µg/L	<0.01	0.056	CTR-CCC	No
Beta Endosulfan	µg/L	<0.01	0.056	CTR-CCC	No
Endosulfan Sulfate	µg/L	<0.01	240	CTR-HH	No
Endrin	µg/L	<0.01	0.036	CTR-CCC	No
Endrin Aldehyde	µg/L	<0.01	0.81	CTR-HH	No
Heptachlor	µg/L	<0.01	0.00021	CTR-HH	No
Heptachlor Epoxide	µg/L	<0.01	0.00011	CTR-HH	No
PCBs	µg/L	<0.1	0.00017	CTR-HH	No
Toxaphene	µg/L	<1	0.0002	CTR-CCC	No

¹ The minimum wastewater hardness value of 335 mg/L at Monitoring Location M-001 (May 11, 2020 Data) was used to determine certain metals criteria.

² BPJ means Best Professional Judgement.

³ BP-WQO means Basin Plan WQO.

⁴ RP based on BPJ: Total chlorine residual concentration above 0.1 mg/L is present in the effluent before dechlorination treatment, which may be difficult to control.

⁵ Ammonia-N criteria calculated based on an effluent pH of 7.2 S.U. (see Table 8 and Table 9).

⁶ NTR means National Toxics Rule.

⁷ RP based on BPJ: The ammonia-N concentration in the secondary treated source wastewater received from OC San may vary significantly by 2023.

⁸ CTR-HH means CTR's Human Health for Consumption of Organisms Only.

⁹ CTR-CCC means CTR's Criterion Continuous Concentration for Freshwater.

¹⁰ NC means no criteria was available for the parameter.

¹¹ No data available.

¹² CTR-CMC means CTR's Criterion Maximum Concentration for Freshwater.

4. WQBEL Calculations

a. Calculation of Freshwater Total Ammonia–Nitrogen Criterion

Considering that the discharges to Reach 1 of Santa Ana River are expected to be of limited duration (12 hours) and to occur only infrequently (no more than once every three years), this Order uses the acute criterion for Total Ammonia–Nitrogen to establish total ammonia effluent limitations.

USEPA-NTR specifies that the one-hour average concentration of total ammonia

nitrogen, as N/L, does not exceed, more than once every three years on the average, the acute criterion. The acute criterion for Total Ammonia–Nitrogen is calculated using the following equation:

$$CMC = 0.411 / (1 + 10^{7.204 - pH}) + 58.4 / (1 + 10^{pH - 7.204})$$

Table 8. Calculated Ammonia-Nitrogen Acute Criterion

pH	mg/L
7.2	29.5
7.5	20
7.7	14

b. Effluent Calculations

Table 9. Ammonia-Nitrogen Effluent Limits Calculation, mg/L

		CV= 0.18, long-term average			Aquatic Life		Permit Limit	
Total Ammonia-Nitrogen	NTR	Acute M	Chronic M	LTA	Objective/limits		Concentration Limit	
		0.673			1.49	1.15		
pH	CMC	Acute LTA	Chronic LTA		MDEL	AMEL	MDEL	AMEL
6.5	48.83	32.9		32.9	49.0	37.8	49	38
6.6	46.84	31.5		31.5	47.0	36.3	47	36
6.7	44.57	30.0		30.0	44.7	34.5	45	34
6.8	42	28.3		28.3	42.1	32.5	42	33
6.9	39.16	26.4		26.4	39.3	30.3	39	30
7.0	36.09	24.29		24.29	36.2	27.9	36	28
7.1	32.54	21.9		21.9	32.6	25.2	33	25
7.2	29.54	19.88		19.88	29.6	22.9	30	23
7.3	26.21	17.6		17.6	26.3	20.3	26	20
7.4	22.97	15.46		15.46	23.0	17.8	23	18
7.5	19.86	13.4		13.4	19.9	15.4	20	15
7.6	17.03	11.46		11.46	17.1	13.2	17	13
7.7	14.44	9.7		9.7	14.5	11.2	14	11
7.8	12.14	8.17		8.17	12.2	9.4	12	9.4
7.9	10.13	6.8		6.8	10.2	7.8	10	7.8
8.0	8.41	5.66		5.66	8.4	6.5	8.4	6.5
8.1	6.95	4.7		4.7	7.0	5.4	7.0	5.4
8.2	5.73	3.86		3.86	5.7	4.4	5.7	4.4
8.3	4.71	3.2		3.2	4.7	3.6	4.7	3.6
8.4	3.88	2.61		2.61	3.9	3.0	3.9	3.0
8.5	3.2	2.2		2.2	3.2	2.5	3.2	2.5

D. Summary of Final Effluent Limitations for DP 001

1. Satisfaction of Anti-Backsliding Requirements

Sections 402(o) and 303(d)(4) of the CWA and federal regulations at 40 CFR 122.44(l) prohibit backsliding in NPDES permits. These anti-backsliding provisions require effluent limitations in a reissued permit to be as stringent as those in the previous permit, with some exceptions where limitations may be relaxed. The effluent limitations in this Order are at least as stringent as the effluent limitations in the previous Order, except for effluent limitations for selenium and free cyanide. Effluent limitations for selenium and free cyanide are discontinued in this Order based on the consideration of new information (i.e., current discharge monitoring data and reasonable potential analysis). This relaxation of effluent limitations is consistent with the anti-backsliding requirements included in section 402(o)(2)(B)(i) of the CWA and federal regulations.

2. Satisfaction of Antidegradation Policy

Discharges are expected to be limited in duration and frequency and, if conducted in conformance with the requirements of this Order, will not result in a lowering of water quality. The discharges therefore conform to antidegradation requirements specified in Resolution No. 68-16, which incorporates the federal antidegradation policy at 40 CFR 131.12.

3. Stringency of Requirements for Individual Pollutants

Water quality-based effluent limitations have been scientifically derived to implement water quality objectives that protect beneficial uses. Both the beneficial uses and the water quality objectives have been approved pursuant to federal law and are the applicable federal water quality standards. To the extent that toxic pollutant water quality-based effluent limitations were derived from the CTR, the CTR is the applicable standard pursuant to 40 CFR 131.38. The scientific procedures for calculating the individual water quality-based effluent limitations for priority pollutants are based on the CTR-SIP, which was approved by USEPA on May 18, 2000. Apart from certain surface water standards changes resulting from the N/TDS Basin Plan amendment that do not materially affect the quality requirements for the discharges regulated by this Order, all beneficial uses and water quality objectives contained in the Basin Plan were approved under state law and submitted to and approved by USEPA prior to May 30, 2000. Any water quality objectives and beneficial uses submitted to USEPA prior to May 30, 2000, but not approved by USEPA before that date, are nonetheless “applicable water quality standards for purposes of the CWA” pursuant to 40 CFR 131.21(c)(1). Collectively, this Order’s restrictions on individual pollutants are no more stringent than required to implement the requirements of the CWA.

4. Summary of Final Effluent Limitations for DP 001:

Table 10. Summary of Water Quality-Based Effluent Limits at DP 001

Parameter	Units	Effluent Limitations					Basis
		Average Monthly* or as noted herein	Average Weekly	Max Daily	Instantaneous Minimum	Instantaneous Maximum	
BOD ₅	mg/L	20	30	--	--	--	BPJ**
Total Suspended Solids	mg/L	20	30	--	--	--	BPJ
pH	Std. unit	--	--	--	6.5	8.5	Basin Plan
Total Residual Chlorine	mg/L			0.1			BPJ/Basin Plan
Total Coliform	MPN	--		2.2 MPN***	--	--	BPJ/Title 22

- * The AMEL applies only if discharges occur for more than one day in a calendar month period
- ** BPJ – Best Professional Judgement
- *** Daily Average

Table 11. Summary of Total Ammonia-Nitrogen Effluent Limits at DP 001

pH	Maximum Daily (mg/L)	Average Monthly* (mg/L)
6.5	49	38
6.6	47	36
6.7	45	34
6.8	42	33
6.9	39	30
7.0	36	28
7.1	33	25
7.2	30	23
7.3	26	20
7.4	23	18

Table 11. Summary of Total Ammonia-Nitrogen Effluent Limits at DP 001

pH	Maximum Daily (mg/L)	Average Monthly* (mg/L)
7.5	20	15
7.6	17	13
7.7	14	11
7.8	12	9.4
7.9	10	7.8
8.0	8.4	6.5
8.1	7.0	5.4
8.2	5.7	4.4
8.3	4.7	3.6
8.4	3.9	3.0
8.5	3.2	2.5

* The average monthly effluent limitation (AMEL) applies only if there is more than one-day discharge in a calendar month period.

E. Interim Effluent Limitations for DP 001 - Not Applicable

F. Land Discharge Specifications – Not Applicable

G. Reclamation Specifications – Not Applicable

Recycled water recharge into groundwater is regulated under Order No. R8-2004-002, as amended.

H. Stormwater Discharge Requirements

Pursuant to § 402(p) of the Clean Water Act and Title 40 of the Code of Federal Regulations (CFR) Part 122, 123, and 124, the State Water Resources Control Board adopted a general NPDES permit to regulate storm water discharges associated with industrial activities (State Water Board Industrial General Permit Order No. 2014-0057-DWQ, NPDES No. CAS000001) on April 1, 2014 and became effective on July 1, 2015. Storm water discharges from the Facility are regulated under the State Water Board Industrial General Permit Order No. 2014-0057-DWQ (as amended by Orders 2015-0122-DWQ and the 2018 Amendment documents).

V. RATIONALE FOR RECEIVING WATER LIMITATIONS

A. Surface Water

The surface water receiving water limitations in this Order are based upon the water quality objectives contained in the Basin Plan. As such, they are required part of the proposed Order.

B. Groundwater – Not Applicable

VI. RATIONALE FOR MONITORING AND REPORTING REQUIREMENTS

Section 13267 and 13383 authorize the Santa Ana Water Boards to require technical and monitoring reports. In addition, 40 CFR 122.48 requires all NPDES permits to specify recording and reporting of monitoring results. The Monitoring and Reporting Program (MRP), Attachment E of this Order, establishes monitoring and reporting requirements to implement federal and State requirements. The following provides the rationale for the monitoring and reporting requirements contained in the MRP for this Facility.

A. General Monitoring Provisions

In addition to containing definitions of terms, the MRP specifies general sampling/analytical protocols and the requirements of reporting of spills, violations, and routine monitoring data in accordance with the California Water Code, NPDES regulations, and Santa Ana Water Board's policies.

B. Effluent Monitoring

The Discharger is required to conduct monitoring of the discharge in order to evaluate compliance with permit conditions. The MRP also contains an effluent sampling program specific to this facility. It defines the sampling stations and frequency, pollutants to be monitored, and additional reporting requirements. Pollutants to be monitored include all pollutants for which effluent limitations are specified. Further, in accordance with Section 1.3 of the SIP, periodic monitoring is required for all priority pollutants defined by the CTR, for which criteria apply and for which no effluent limitations have been established, to evaluate reasonable potential to cause or contribute to an excursion above a water quality standard.

VII. RATIONALE FOR PROVISIONS

A. Federal Standard Provisions

Federal Standard Provisions, which apply to all NPDES permits in accordance with 40 CFR 122.41, and additional conditions applicable to specified categories of permits in accordance with 40 CFR 122.42, are provided in Attachment D. The Discharger must comply with all standard provisions and with those additional conditions that are applicable under 40 CFR 122.42.

40 CFR 122.41(a)(1) and (b) through (n) establish conditions that apply to all State-issued NPDES permits. These conditions must be incorporated into the permits either expressly or by reference. If incorporated by reference, a specific citation to the regulations must be included in the Order. 40 CFR 123.25(a)(12) allows the state to omit or modify conditions to impose more stringent requirements. In accordance with 40 CFR 123.25, this Order omits federal conditions that address enforcement authority specified in 40 CFR 122.41(j)(5) and (k)(2) because the enforcement authority under the CWC is more stringent. In lieu of these conditions, this Order incorporates by reference CWC's § 13387(e).

B. Special Provisions

1. Reopener Provisions

The provisions are based on 40 CFR Parts 122.44(c) and 123. The Santa Ana Water Board may reopen the permit to modify permit conditions and requirements. Causes for modifications include the promulgation of new regulations, modification in sludge use or disposal practices, or adoption of new regulations by the State Water Board or Santa Ana Water Board, including revisions to the Basin Plan.

2. Special Studies and Additional Monitoring Requirements – Not Applicable

3. Best Management Practices and Pollution Prevention – Not Applicable

4. Construction, Operation, and Maintenance Specifications – Not Applicable

Construction, Operation, and Maintenance Specifications are included in Order No. R8-2004-0002 which regulates use of recycled water from the GWRS for recharge.

5. Special Provisions for Municipal Facilities - POTWs Only – Not Applicable

6. Other Special Provisions – Not Applicable

7. Compliance Schedules – Not Applicable

VIII. PUBLIC PARTICIPATION

The Santa Ana Water Board has considered the issuance of waste discharge requirements (WDRs) that will serve as a National Pollutant Discharge Elimination System (NPDES) permit for the Orange County Water District's Advanced Water Purification Facility, emergency discharge to Reach 1 of Santa Ana River. As a step in the WDRs adoption process, the Santa Ana Water Board staff has developed tentative WDRs and has encourages public participation in the WDR adoption process.

A. Notification of Interested Parties

The Santa Ana Water Board has notified the Discharger and interested agencies and persons of its intent to prescribe WDRs for the discharge and has provided an opportunity to submit written comments and recommendations. Notification was provided through the posting of Notice of Public Hearing on the Santa Ana Water Board's website: <http://www.waterboards.ca.gov/santaana> on or before January 21, 2022.

B. Written Comments

Interested persons were invited to submit written comments concerning tentative WDRs as provided through the notification process. Comments were due either in person or by mail to the Executive Office at the Santa Ana Water Board at the address on the cover page of this Order, by fax to (951) 781-6288, or by email to Ryan Harris at Ryan.Harris@waterboards.ca.gov.

To be fully responded to by staff and considered by the Santa Ana Water Board, the written comments were due at the Santa Ana Water Board offices by 5:00 p.m. on February 28, 2022.

C. Public Hearing

The Santa Ana Water Board held a public hearing on the tentative WDRs during its regular Board meeting on the following date and time and at the following location:

Date: March 18, 2022
Time: 9:00 A.M.
Location: Meeting was remote, due to COVID-19 restrictions

Interested persons were invited to attend. At the public hearing, the Santa Ana Water Board heard testimony pertinent to the discharge, WDRs, and permit. For accuracy of the record, extensive testimony was requested in writing.

D. Reconsideration of Waste Discharge Requirements

Any person aggrieved by this action of the Santa Ana Water Board may petition the State Water Resources Control Board to review the action in accordance with Water Code section 13320 and California Code of Regulations, title 23, sections 2050 and following. The State Water Board must receive the petition by 5:00 p.m., within 30 calendar days of the date of adoption of this Order at the following address, except that if the thirtieth day following the date of this Order falls on a Saturday, Sunday, or state holiday, the petition must be received by the State Water Board by 5:00 p.m. on the next business day:

State Water Resources Control Board

Office of Chief Counsel
P.O. Box 100, 1001 I Street
Sacramento, CA 95812-0100

Or by email at waterqualitypetitions@waterboards.ca.gov

For instructions on how to file a petition for review, see:
<http://www.waterboards.ca.gov/public_notices/petitions/water_quality/wqpetition_instr.shtml>

E. Information and Copying

The Report of Waste Discharge, other supporting documents, and comments received are on file and may be inspected at the address above at any time between 8:30 a.m. and 4:45 p.m., Monday through Friday. Copying of documents may be arranged through the Santa Ana Water Board by calling (951) 782-4130.

F. Register of Interested Persons

Any person interested in being placed on the mailing list for information regarding the WDRs and NPDES permit should contact the Santa Ana Water Board, reference this facility, and provide a name, address, and phone number.

G. Additional Information

Requests for additional information or questions regarding this Order should be directed to Ryan Harris at (951) 320-2008 or Ryan.Harris@waterboards.ca.gov.

ATTACHMENT G - EPA PRIORITY POLLUTANT LIST

EPA PRIORITY POLLUTANT LIST		
Metals	Acid Extractibles	Base/Neutral Extractibles (continuation)
1. Antimony	45. 2-Chlorophenol	91. Hexachloroethane
2. Arsenic	46. 2,4-Dichlorophenol	92. Indeno (1,2,3-cd) Pyrene
3. Beryllium	47. 2,4-Dimethylphenol	93. Isophorone
4. Cadmium	48. 2-Methyl-4,6-Dinitrophenol	94. Naphthalene
5a. Chromium (III)	49. 2,4-Dinitrophenol	95. Nitrobenzene
5b. Chromium (VI)	50. 2-Nitrophenol	96. N-Nitrosodimethylamine
6. Copper	51. 4-Nitrophenol	97. N-Nitrosodi-N-Propylamine
7. Lead	52. 3-Methyl-4-Chlorophenol	98. N-Nitrosodiphenylamine
8. Mercury	53. Pentachlorophenol	99. Phenanthrene
9. Nickel	54. Phenol	100. Pyrene
10. Selenium	55. 2, 4, 6 – Trichlorophenol	101. 1,2,4-Trichlorobenzene
11. Silver	Base/Neutral Extractibles	Pesticides
12. Thallium	56. Acenaphthene	102. Aldrin
13. Zinc	57. Acenaphthylene	103. Alpha BHC
Miscellaneous	58. Anthracene	104. Beta BHC
14. Cyanide, Free	59. Benzidine	105. Delta BHC
15. Asbestos (not required unless requested)	60. Benzo (a) Anthracene	106. Gamma BHC
16. 2,3,7,8-Tetrachlorodibenzo-P-Dioxin (TCDD)	61. Benzo (a) Pyrene	107. Chlordane
Volatile Organics	62. Benzo (b) Fluoranthene	108. 4, 4' - DDT
17. Acrolein	63. Benzo (g,h,i) Perylene	109. 4, 4' - DDE
18. Acrylonitrile	64. Benzo (k) Fluoranthene	110. 4, 4' - DDD
19. Benzene	65. Bis (2-Chloroethoxy) Methane	111. Dieldrin
20. Bromoform	66. Bis (2-Chloroethyl) Ether	112. Alpha Endosulfan
21. Carbon Tetrachloride	67. Bis (2-Chloroisopropyl) Ether	113. Beta Endosulfan
22. Chlorobenzene	68. Bis (2-Ethylhexyl) Phthalate	114. Endosulfan Sulfate
23. Chlorodibromomethane	69. 4-Bromophenyl Phenyl Ether	115. Endrin
24. Chloroethane	70. Butylbenzyl Phthalate	116. Endrin Aldehyde
25. 2-Chloroethyl Vinyl Ether	71. 2-Chloronaphthalene	117. Heptachlor
26. Chloroform	72. 4-Chlorophenyl Phenyl Ether	118. Heptachlor Epoxide
27. Dichlorobromomethane	73. Chrysene	119. PCB 1016

28.	1,1-Dichloroethane	74.	Dibenzo (a,h) Anthracene	120.	PCB 1221
29.	1,2-Dichloroethane	75.	1,2-Dichlorobenzene	121.	PCB 1232
30.	1,1-Dichloroethylene	76.	1,3-Dichlorobenzene	122.	PCB 1242
31.	1,2-Dichloropropane	77.	1,4-Dichlorobenzene	123.	PCB 1248
32.	1,3-Dichloropropylene	78.	3,3'-Dichlorobenzidine	124.	PCB 1254
33.	Ethylbenzene	79.	Diethyl Phthalate	125.	PCB 1260
34.	Methyl Bromide	80.	Dimethyl Phthalate	126.	Toxaphene
35.	Methyl Chloride	81.	Di-n-Butyl Phthalate		
36.	Methylene Chloride	82.	2,4-Dinitrotoluene		
37.	1,1,2,2-Tetrachloroethane	83.	2,6-Dinitrotoluene		
38.	Tetrachloroethylene	84.	Di-n-Octyl Phthalate		
39.	Toluene	85.	1,2-Diphenylhydrazine		
40.	1,2-Trans-Dichloroethylene	86.	Fluoranthene		
41.	1,1,1-Trichloroethane	87.	Fluorene		
42.	1,1,2-Trichloroethane	88.	Hexachlorobenzene		
43.	Trichloroethylene	89.	Hexachlorobutadiene		
44.	Vinyl Chloride	90.	Hexachlorocyclopentadiene		

ATTACHMENT H – MINIMUM LEVELS

MINIMUM LEVELS IN PPB (µg/l)

Table 1- VOLATILE SUBSTANCES¹	GC	GCMS
Acrolein	2.0	5
Acrylonitrile	2.0	2
Benzene	0.5	2
Bromoform	0.5	2
Carbon Tetrachloride	0.5	2
Chlorobenzene	0.5	2
Chlorodibromomethane	0.5	2
Chloroethane	0.5	2
Chloroform	0.5	2
Dichlorobromomethane	0.5	2
1,1 Dichloroethane	0.5	1
1,2 Dichloroethane	0.5	2
1,1 Dichloroethylene	0.5	2
1,2 Dichloropropane	0.5	1
1,3 Dichloropropylene (volatile)	0.5	2
Ethylbenzene	0.5	2
Methyl Bromide (<i>Bromomethane</i>)	1.0	2
Methyl Chloride (<i>Chloromethane</i>)	0.5	2
Methylene Chloride (<i>Dichloromethane</i>)	0.5	2
1,1,2,2 Tetrachloroethane	0.5	1
Tetrachloroethylene	0.5	2
Toluene	0.5	2
trans-1,2 Dichloroethylene	0.5	1
1,1,1 Trichloroethane	0.5	2
1,1,2 Trichloroethane	0.5	2
Trichloroethylene	0.5	2
Vinyl Chloride	0.5	2
1,2 Dichlorobenzene (volatile)	0.5	2
1,3 Dichlorobenzene (volatile)	0.5	2
1,4 Dichlorobenzene (volatile)	0.5	2

SELECTION AND USE OF APPROPRIATE ML VALUE:

ML Selection: When there is more than one ML value for a given substance, the discharger may select any one of those ML values, and their associated analytical methods, listed in this Attachment that are below the calculated effluent limitation for compliance determination. If no ML value is below the effluent limitation, then the

¹ *The normal method-specific factor for these substances is 1, therefore, the lowest standard concentration in the calibration curve is equal to the above ML value for each substance.*

discharger shall select the lowest ML value, and its associated analytical method, listed in the PQL Table.

ML Usage: The ML value in this Attachment represents the lowest quantifiable concentration in a sample based on the proper application of all method-based analytical procedures and the absence of any matrix interferences. Assuming that all method-specific analytical steps are followed, the ML value will also represent, after the appropriate application of method-specific factors, the lowest standard in the calibration curve for that specific analytical technique. Common analytical practices sometimes require different treatment of the sample relative to calibration standards.

Note: chemical names in parenthesis and italicized is another name for the constituent.

MINIMUM LEVELS IN PPB (µg/l)

Table 2 – Semi-Volatile Substances²	GC	GCMS	LC
2-Chloroethyl vinyl ether	1	1	
2 Chlorophenol	2	5	
2,4 Dichlorophenol	1	5	
2,4 Dimethylphenol	1	2	
4,6 Dinitro-2-methylphenol	10	5	
2,4 Dinitrophenol	5	5	
2- Nitrophenol		10	
4- Nitrophenol	5	10	
4 Chloro-3-methylphenol	5	1	
2,4,6 Trichlorophenol	10	10	
Acenaphthene	1	1	0.5
Acenaphthylene		10	0.2
Anthracene		10	2
Benzidine		5	
Benzo (a) Anthracene (1,2 <i>Benzanthracene</i>)	10	5	
Benzo(a) pyrene (3,4 <i>Benzopyrene</i>)		10	2
Benzo (b) Flouranthene (3,4 <i>Benzofluoranthene</i>)		10	10
Benzo(g,h,i)perylene		5	0.1
Benzo(k)fluoranthene		10	2
bis 2-(1-Chloroethoxyl) methane		5	
bis(2-chloroethyl) ether	10	1	
bis(2-Chloroisopropyl) ether	10	2	
bis(2-Ethylhexyl) phthalate	10	5	
4-Bromophenyl phenyl ether	10	5	
Butyl benzyl phthalate	10	10	
2-Chloronaphthalene		10	
4-Chlorophenyl phenyl ether		5	

Chrysene		10	5
Dibenzo(a,h)-anthracene		10	0.1
1,2 Dichlorobenzene (semivolatile)	2	2	
1,3 Dichlorobenzene (semivolatile)	2	1	
1,4 Dichlorobenzene (semivolatile)	2	1	
3,3' Dichlorobenzidine		5	
Diethyl phthalate	10	2	
Dimethyl phthalate	10	2	
di-n-Butyl phthalate		10	
2,4 Dinitrotoluene	10	5	
2,6 Dinitrotoluene		5	
di-n-Octyl phthalate		10	
1,2 Diphenylhydrazine		1	
Fluoranthene	10	1	0.05
Fluorene		10	0.1
Hexachloro-cyclopentadiene	5	5	
1,2,4 Trichlorobenzene	1	5	

MINIMUM LEVELS IN PPB (µg/l)

Table 2 - SEMI-VOLATILE SUBSTANCES²	GC	GCMS	LC	COLOR
Pentachlorophenol	1	5		
Phenol ³	1	1		50
Hexachlorobenzene	5	1		
Hexachlorobutadiene	5	1		
Hexachloroethane	5	1		
Indeno(1,2,3,cd)-pyrene		10	0.05	
Isophorone	10	1		
Naphthalene	10	1	0.2	
Nitrobenzene	10	1		
N-Nitroso-dimethyl amine	10	5		
N-Nitroso -di n-propyl amine	10	5		
N-Nitroso diphenyl amine	10	1		
Phenanthrene		5	0.05	
Pyrene		10	0.05	

² With the exception of phenol by colorimetric technique, the normal method-specific factor for these substances is 1000, therefore, the lowest standards concentration in the calibration curve is equal to the above ML value for each substance multiplied by 1000.

³ Phenol by colorimetric technique has a factor of 1.

Table 3– INORGANICS⁴	FA A	GFA A	IC P	ICPM S	SPGF AA	HYDRI DE	CVA A	COL OR	DCP
Antimony	10	5	50	0.5	5	0.5			1000
Arsenic		2	10	2	2	1		20	1000
Beryllium	20	0.5	2	0.5	1				1000
Cadmium	10	0.5	10	0.25	0.5				1000
Chromium (total)	50	2	10	0.5	1				1000
Chromium VI	5							10	
Copper	25	5	10	0.5	2				1000
Lead	20	5	5	0.5	2				1000 0
Mercury				0.5			0.2		
Nickel	50	5	20	1	5				1000
Selenium		5	10	2	5	1			1000
Silver	10	1	10	0.25	2				1000
Thallium	10	2	10	1	5				1000
Zinc	20		20	1	10				1000
Cyanide								5	

MINIMUM LEVELS IN PPB (µg/l)

Table 4- PESTICIDES – PCBs⁵	GC
Aldrin	0.005
alpha-BHC (<i>a</i> -Hexachloro-cyclohexane)	0.01
beta-BHC (<i>b</i> -Hexachloro-cyclohexane)	0.005
Gamma-BHC (<i>Lindane</i> ; <i>g</i> -Hexachloro-cyclohexane)	0.02
Delta-BHC (<i>d</i> -Hexachloro-cyclohexane)	0.005
Chlordane	0.1
4,4'-DDT	0.01
4,4'-DDE	0.05
4,4'-DDD	0.05
Dieldrin	0.01
Alpha-Endosulfan	0.02
Beta-Endosulfan	0.01
Endosulfan Sulfate	0.05

⁴ The normal method-specific factor for these substances is 1, therefore, the lowest standard concentration in the calibration curve is equal to the above ML value for each substance.

⁵ The normal method-specific factor for these substances is 100, therefore, the lowest standard concentration in the calibration curve is equal to the above ML value for each substance multiplied by 100.

Endrin	0.01
Endrin Aldehyde	0.01
Heptachlor	0.01
Heptachlor Epoxide	0.01
PCB 1016	0.5
PCB 1221	0.5
PCB 1232	0.5
PCB 1242	0.5
PCB 1248	0.5
PCB 1254	0.5
PCB 1260	0.5
Toxaphene	0.5

Techniques:

GC - Gas Chromatography

GCMS - Gas Chromatography/Mass Spectrometry

HRGCMS - High Resolution Gas Chromatography/Mass Spectrometry (i.e., EPA 1613, 1624, or 1625)

LC - High Pressure Liquid Chromatography

FAA - Flame Atomic Absorption

GFAA - Graphite Furnace Atomic Absorption

HYDRIDE - Gaseous Hydride Atomic Absorption

CVAA - Cold Vapor Atomic Absorption

ICP - Inductively Coupled Plasma

ICPMS - Inductively Coupled Plasma/Mass Spectrometry

SPGFAA - Stabilized Platform Graphite Furnace Atomic Absorption (i.e., EPA 200.9)

DCP - Direct Current Plasma

COLOR - Colorimetric