



California Regional Water Quality Control Board

San Francisco Bay Region



Linda S. Adams
Secretary for
Environmental Protection

1515 Clay Street, Suite 1400, Oakland, California 94612
(510) 622-2300 • Fax (510) 622-2460
<http://www.waterboards.ca.gov/sanfranciscobay>

Arnold Schwarzenegger
Governor

ORDER NO. R2-2008-0056
NPDES NO. CA0030058

WASTE DISCHARGE REQUIREMENTS FOR BOTTLING GROUP, LLC HAYWARD, ALAMEDA COUNTY

The following Discharger is authorized to discharge in accordance with the conditions set forth in this Order:

Table 1. Discharger Information

Discharger	Bottling Group, LLC
Name of Facility	Bottling Group Hayward Plant
Facility Address	29000 Hesperian Boulevard
	Hayward, CA 94545
	Alameda County

The discharge by the Bottling Group, LLC from the discharge point identified below is subject to waste discharge requirements as set forth in this Order:

Table 2. Discharge Location

Discharge Point	Effluent Description	Discharge Point Latitude	Discharge Point Longitude	Receiving Water
001	Reverse Osmosis Concentrate	37° 36' 54" N	122° 5' 4" W	Alameda County Flood Control and Water Conservation District (ACFCWCD) Flood Channel

Table 3. Administrative Information

This Order was adopted by the Regional Water Board on:	July 9, 2008
This Order shall become effective on:	September 1, 2008
This Order shall expire on:	August 31, 2013
The U.S. Environmental Protection Agency (USEPA) and the Regional Water Quality Control Board (Regional Water Board) have classified this discharge as a minor discharge.	
The Discharger shall file a Report of Waste Discharge in accordance with Title 23, California Code of Regulations, not later than 180 days in advance of the Order expiration date as application for issuance of new waste discharge.	

I, Bruce H. Wolfe, Executive Officer, do hereby certify the following is a full, true, and correct copy of an Order adopted by the California Regional Water Quality Control Board, San Francisco Bay Region, on July 9, 2008.

Bruce H. Wolfe, Executive Officer

Table of Contents

I.	Facility Information	5
II.	Findings.....	6
III.	Discharge Prohibitions.....	11
IV.	Effluent Limitations and Discharge Specifications	11
	A. Effluent Limitations – Discharge Point 001	11
	B. Interim Effluent Limitations.....	12
	C. Land Discharge Specifications.....	12
	D. Reclamation Specifications	12
V.	Receiving Water Limitations	12
	A. Surface Water Limitations.....	12
	B. Groundwater Limitations	13
VI.	Provisions.....	13
	A. Standard Provisions.....	13
	B. Monitoring and Reporting Program (MRP) Requirements.....	14
	C. Special Provisions	14
	1. Reopener Provisions.....	14
	2. Special Studies, Technical Reports and Additional Monitoring Requirements.....	14
	3. Construction, Operation and Maintenance Specifications	15
	4. Other Special Provisions	16
VII.	Compliance Determination	18

Tables

Table 1.	Discharger Information.....	1
Table 2.	Discharge Location.....	1
Table 3.	Administrative Information	1
Table 4.	Facility Information	5
Table 5.	Basin Plan Beneficial Uses of Alameda Creek and its Tributaries.....	8
Table 6.	Conventional Pollutant Effluent Limitations for Discharge Point 001.....	11

Attachments

Attachment A – Definitions	A-1
Attachment B – Facility Map.....	B-1
Attachment C – Process Flow Diagram.....	C-1
Attachment D – Federal Standard Provisions.....	D-1
Attachment E – Monitoring and Reporting Program (MRP).....	E-1
Attachment F – Fact Sheet.....	F-1
Attachment G – The following documents are part of this Permit, but are not physically attached due to volume. They are available on the internet at www.waterboards.ca.gov/sanfranciscobay/	
- Self-Monitoring Program, Part A, adopted August 1993	
- Standard Provisions and Reporting Requirements, August 1993	
- Regional Water Board Resolution 74-10	

- August 6, 2001 Staff Letter: *Requirement for Priority Pollutant Monitoring in Receiving Water and Wastewater Discharges*

I. FACILITY INFORMATION

The following Discharger is authorized to discharge in accordance with the conditions set forth in this Order:

Table 4. Facility Information

Discharger	Bottling Group, LLC
Name of Facility	Bottling Group Hayward Plant
Facility Address	29000 Hesperian Boulevard
	Hayward, CA 94545
	Alameda County
Facility Contact, Title, and Phone	Wendy Smith, Plant Manager, (510) 781-3627
Mailing Address	Same as above
Type of Facility	Bottled water and soft drink manufacturing, bottling and distribution facility
Facility Design Flow	143,000 gallons per day (projected average monthly discharge rate)
	110,000 gallons per day (current average monthly discharge rate)
	180,000 gallons per day (current maximum daily discharge rate)

II. FINDINGS

The California Regional Water Quality Control Board, San Francisco Bay Region (hereinafter the Regional Water Board), finds:

A. Background. The Bottling Group, LLC (hereinafter the Discharger) is currently discharging under National Pollutant Discharge Elimination System (NPDES) Permit No. CA0030058 (Order No. R2-2003-0051). The Discharger submitted a Report of Waste Discharge, dated November 30, 2007, and applied for an NPDES permit reissuance to discharge up to 0.143 million gallons per day (mgd) of reverse osmosis concentrate from the Hayward Plant.

For the purposes of this Order, references to the “discharger” or “permittee” in applicable federal and state laws, regulations, plans, or policy are held to be equivalent to references to the Discharger herein.

B. Facility Description. The Discharger owns and operates the Bottling Group Hayward Plant, which is a bottled water and soft drink manufacturing, bottling and distribution facility. Attachment B provides a map of the area and the facility.

The Hayward Plant uses potable water supplied by the City of Hayward. This water must undergo additional treatment for the manufacture of soft drinks and bottled water. Filtration is accomplished with anthracite and manganese greensand filters for removal of iron and manganese, followed by 5 micrometer (μm) cartridge filters. Chemical scale and fouling inhibitors are added to the filtered water to prevent fouling of the reverse osmosis (RO) membranes, which achieve 99 percent reduction of dissolved solids at an approximately 80 percent recovery rate. This means 80 percent of the filtered water is recovered as permeate and 20 percent, which contains 99 percent of the original dissolved solids, is discharged in the RO reject or concentrate stream. RO product is filtered by granular activated carbon and a final polishing filter before being disinfected with ultraviolet light. The Discharger’s RO system is rated to process a maximum influent stream of 900,000 gallons per day. The treatment facility flow schematic is shown as Attachment C.

The RO concentrate stream is discharged to an onsite storm drain from Discharge Point 001. The storm drain flows to an offsite storm sewer that drains to the wet well of the Alameda County Besco Pump Station. The pump station discharges to the Alameda County Flood Control and Water Conservation District Flood Channel (Flood Channel), which drains to Old Alameda Creek. Old Alameda Creek is the downstream section of Alameda Creek and is tributary to Lower San Francisco Bay. The Discharger discharges an average monthly flow of 110,000 gallons per day and a maximum daily flow of 180,000 gallons per day of the RO concentrate.

In its Report of Waste Discharge, dated November 30, 2007, the Discharger states that it anticipates a 30 percent increase in production at its Hayward Plant. This would increase the effluent volume discharged to the Flood Channel. Order No. R2-2003-0051 limited the average monthly discharge to 110,000 gallons per day. The Discharger thus requested an increase in the permitted average monthly discharge to 143,000 gallons per day, which this Order provides.

C. Legal Authorities. This Order is issued pursuant to section 402 of the federal Clean Water Act (CWA) and implementing regulations adopted by the USEPA and Chapters 5.5, Division 7 of the California Water Code (CWC) (commencing with section 13370). It shall serve as an NPDES permit for point source discharges from this facility to surface waters. This Order also serves as

Waste Discharge Requirements (WDRs) pursuant to Article 4, Chapter 4, Division 7 of the Water Code (commencing with section 13260).

- D. Background and Rationale for Requirements.** The Regional Water Board developed the requirements in this Order based on information submitted as part of the application, through monitoring and reporting programs, and other available information. Attachments A through G, which contain background information and rationale for Order requirements, are hereby incorporated into this Order and thus constitute part of the Findings for this Order.
- E. California Environmental Quality Act (CEQA).** Under Water Code section 13389, this action to adopt an NPDES permit is exempt from the provisions of CEQA.
- F. Technology-Based Effluent Limitations.** CWA Section 301(b) and NPDES regulations at 40 CFR §122.44 require that permits include conditions meeting applicable technology-based requirements at a minimum and any more stringent effluent limitations necessary to meet applicable water quality standards. The discharge authorized by this Order must meet minimum federal technology-based requirements based on Best Professional Judgment (BPJ) pursuant to 40 CFR §125.3. A detailed discussion of development of the technology-based effluent limitations is included in the Fact Sheet.
- G. Water Quality-Based Effluent Limitations.** CWA section 301(b) and NPDES regulations at 40 CFR §122.44(d) require that permits include limitations more stringent than applicable federal technology-based requirements where necessary to achieve applicable water quality standards.

NPDES regulations at 40 CFR §122.44(d)(1)(i) mandate that permits include effluent limitations for all pollutants that are or may be discharged at levels that have the reasonable potential to cause or contribute to an exceedance of a water quality standard, including numeric and narrative objectives within a standard. Where reasonable potential has been established for a pollutant, but there is no numeric criterion or objective for the pollutant, water quality-based effluent limitations (WQBELs) must be established using: (1) USEPA criteria guidance under CWA section 304(a), supplemented where necessary by other relevant information; (2) an indicator parameter for the pollutant of concern; or (3) a calculated numeric water quality criterion, such as a proposed state criterion or policy interpreting the state's narrative criterion, supplemented with other relevant information, as provided in 40 CFR §122.44(d)(1)(vi).

- G. Water Quality Control Plans.** *The Water Quality Control Plan for the San Francisco Bay Basin* (the Basin Plan) is the Regional Water Board's master water quality control planning document. It designates beneficial uses and water quality objectives for waters of the State, including surface waters and groundwater. It also includes programs of implementation to achieve water quality objectives. The Basin Plan was duly adopted by the Regional Water Board and approved by the State Water Resources Control Board (State Water Board), USEPA, and the Office of Administrative Law, as required.

The Basin Plan does not designate beneficial uses specifically for the Flood Channel, but does identify beneficial uses for Alameda Creek, to which the Flood Channel is tributary. Beneficial uses applicable to Alameda Creek and its tributaries are listed in Table 5. The Basin Plan implements State Water Board Resolution No. 88-63, which establishes State policy that all waters, with certain exceptions, should be considered suitable or potentially suitable for municipal or domestic supply (MUN). Because the Flood Channel is a system designed to collect storm water runoff and is

monitored pursuant to the Alameda Countywide NPDES Municipal Storm Water Permit (Order No. R2-2003-0021) to assure compliance with water quality objectives, this receiving water meets an exception to State Water Board Resolution No. 88-63. Therefore, the MUN designation is not applicable to the Flood Channel.

Table 5. Basin Plan Beneficial Uses of Alameda Creek and its Tributaries

Discharge Point	Receiving Water Name	Beneficial Uses
001	Alameda Creek	Agricultural Supply (AGR) Groundwater Recharge (GWR) Cold Freshwater Habitat (COLD) Warm Freshwater Habitat (WARM) Water Contact Recreation (REC1) Non-Contact Water Recreation (REC2) Wildlife Habitat (WILD) Fish Migration (MIGR) Fish Spawning (SPWN)

Requirements of this Order specifically implement the Basin Plan.

- I. National Toxics Rule (NTR) and California Toxics Rule (CTR).** USEPA adopted the NTR on December 22, 1992, and later amended it on May 4, 1995 and November 9, 1999. About forty criteria in the NTR applied in California. On May 18, 2000, USEPA adopted the CTR. The CTR promulgated new toxics criteria for California and, in addition, incorporated the previously adopted NTR criteria that were applicable in the State. The CTR was amended on February 13, 2001. These rules contain water quality criteria for priority pollutants.
- J. State Implementation Policy.** On March 2, 2000, the State Water Board adopted the *Policy for Implementation of Toxics Standards for Inland Surface Waters, Enclosed Bays, and Estuaries of California* (State Implementation Policy or SIP). The SIP became effective on April 28, 2000 with respect to the priority pollutant criteria promulgated for California by the USEPA through the NTR and to the priority pollutant objectives established by the Regional Water Board in the Basin Plan. The SIP became effective on May 18, 2000 with respect to the priority pollutant criteria promulgated by the USEPA through the CTR. The State Water Board adopted amendments to the SIP on February 24, 2005 that became effective on July 13, 2005. The SIP establishes implementation provisions for priority pollutant criteria and objectives and provisions for chronic toxicity control. Requirements of this Order implement the SIP.
- K. Compliance Schedules and Interim Requirements.** Section 2.1 of the SIP provides that, based on a discharger’s request and demonstration that it is infeasible for an existing discharger to achieve immediate compliance with an effluent limitation derived from a CTR criterion, compliance schedules may be allowed in an NPDES permit. Unless an exception has been granted under section 5.3 of the SIP, a compliance schedule may not exceed five years from the date that the permit is issued or reissued, nor may it extend beyond ten years from the effective date of the SIP (or May 18, 2010) to establish and comply with CTR criterion-based effluent limitations. Where a compliance schedule for a final effluent limitation exceeds one year, the Order must include interim numeric limitations for that constituent or parameter. Where allowed by the Basin Plan, compliance schedules and interim effluent limitations or discharge specifications may also be granted to allow time to implement a new or revised water quality objective. This Order does not include compliance schedules or interim effluent limitations.

L. Alaska Rule. On March 30, 2000, USEPA revised its regulation that specifies when new and revised state and tribal water quality standards become effective for CWA purposes. [65 Fed. Reg. 24641 (April 27, 2000) (codified at 40 CFR §131.21)]. Under the revised regulation (also known as the Alaska Rule), new and revised standards submitted to USEPA after May 30, 2000, must be approved by USEPA before being used for CWA purposes. The final rule also provides that standards already in effect and submitted to USEPA by May 30, 2000 may be used for CWA purposes, whether or not approved by USEPA.

M. Stringency of Requirements for Individual Pollutants. This Order contains both technology-based and WQBELs for individual pollutants. The technology-based effluent limitations consist of restrictions on flow, total chlorine residual, and pH. Derivation of these technology-based limitations is discussed in the Fact Sheet (Attachment F). This Order's technology-based pollutant restrictions implement the minimum applicable federal technology-based requirements. In addition, this Order contains effluent limitations more stringent than the federal technology-based requirements that are necessary to meet water quality standards. These limitations are not more stringent than required by the CWA.

WQBELs have been derived to implement water quality objectives that protect beneficial uses. Both the beneficial uses and the water quality objectives have been approved pursuant to federal law and are the applicable federal water quality standards. To the extent that toxic pollutant WQBELs were derived from the CTR, the CTR is the applicable standard pursuant to 40 CFR §131.38. The procedures for calculating the individual WQBELs for priority pollutants are based on the SIP, which was approved by USEPA on May 18, 2000. All beneficial uses and water quality objectives contained in the Basin Plan were approved under State law and submitted to and approved by USEPA prior to May 30, 2000. Any water quality objectives and beneficial uses submitted to USEPA prior to May 30, 2000, but not approved by USEPA before that date, are nonetheless "applicable water quality standards for purposes of the CWA" pursuant to 40 CFR §131.21(c)(1). Collectively, this Order's restrictions on individual pollutants are no more stringent than required to implement the requirements of the CWA.

N. Antidegradation Policy. NPDES regulations at 40 CFR §131.12 require that the State water quality standards include an antidegradation policy consistent with the federal policy. The State Water Board established California's antidegradation policy in State Water Board Resolution No. 68-16. Resolution No. 68-16 incorporates the federal antidegradation policy where the federal policy applies under federal law. Resolution No. 68-16 requires that existing quality of waters be maintained unless degradation is justified based on specific findings. The Basin Plan implements, and incorporates by reference, both the State and federal antidegradation policies. As discussed in detail in the Fact Sheet, the permitted discharge is consistent with the antidegradation provisions of 40 CFR §131.12 and State Water Board Resolution No. 68-16.

O. Endangered Species Act. This Order does not authorize any act that results in the taking of a threatened or endangered species or any act that is now prohibited, or becomes prohibited in the future, under either the California Endangered Species Act (Fish and Game Code sections 2050 to 2097) or the federal Endangered Species Act (16 U.S.C.A. sections 1531 to 1544). This Order requires compliance with effluent limits, receiving water limits, and other requirements to protect the beneficial uses of waters of the State. The Discharger is responsible for meeting all requirements of the applicable Endangered Species Act.

- P. Monitoring and Reporting.** NPDES regulations at 40 CFR §122.48 require that all NPDES permits specify requirements for recording and reporting monitoring results. Water Code sections 13267 and 13383 authorize the Regional Water Board to require technical and monitoring reports. The Monitoring and Reporting Program establishes monitoring and reporting requirements to implement federal and State requirements. This Monitoring and Reporting Program is provided in Attachment E.
- Q. Standard and Special Provisions.** Standard Provisions, which apply to all NPDES permits in accordance with 40 CFR §122.41, and additional conditions applicable to specified categories of permits in accordance with 40 CFR §122.42, are provided in Attachment D. The Discharger must comply with all standard provisions and with those additional conditions that are applicable under 40 CFR §122.42. The Regional Water Board has also included in this Order special provisions applicable to the Discharger. A rationale for the special provisions contained in this Order is provided in the attached Fact Sheet (Attachment F).
- R. Provisions and Requirements Implementing State Law.** The provisions/requirements in subsections IV.C., IV.D., and V.B. of this Order are included to implement State law only. These provisions/requirements are not required or authorized under the federal CWA; and consequently, violations of these provisions/requirements are not subject to the enforcement remedies that are available for NPDES violations.
- S. Notification of Interested Parties.** The Regional Water Board has notified the Discharger and interested agencies and persons of its intent to prescribe WDRs for the discharge and has provided them with an opportunity to submit their written comments and recommendations. Details of notification are provided in the Fact Sheet (Attachment F) of this Order.
- T. Consideration of Public Comment.** The Regional Water Board, in a public meeting, heard and considered all comments pertaining to the discharge. Details of the Public Hearing are provided in the Fact Sheet of this Order.

IT IS HEREBY ORDERED, Order No. R2-2003-0051 is rescinded upon the effective date of this Order except for enforcement purposes, and, in order to meet the provisions contained in Division 7 of the California Water Code and regulations adopted thereunder, and the provisions of the federal Clean Water Act and regulations and guidelines adopted thereunder, the Discharger shall comply with the requirements in this Order.

III. DISCHARGE PROHIBITIONS

- A. Discharge of treated, untreated, or partially treated wastewater at a location or in a manner different from that described in this Order is prohibited.
- B. Discharge greater than a monthly average flow of 143,000 gallons per day is prohibited.

IV. EFFLUENT LIMITATIONS AND DISCHARGE SPECIFICATIONS

A. Effluent Limitations – Discharge Point 001

1. Effluent Limitations for Conventional Pollutants

- a. The discharge of reverse osmosis concentrate to the Flood Channel shall maintain compliance with the following effluent limitations at Discharge Point 001, with compliance measured at Monitoring Location E-001, as described in the Monitoring and Reporting Program (Attachment E). The discharge from Discharge Point 001 shall not exceed the following limitations.

Table 6. Conventional Pollutant Effluent Limitations for Discharge Point 001

Parameter	Units	Effluent Limitations	
		Instantaneous Minimum	Instantaneous Maximum
pH ⁽¹⁾	standard units	6.5	8.5
Total Chlorine Residual ⁽²⁾	mg/L	---	0.0

Footnotes for Table 6:

- (1) If the Discharger monitors pH continuously, pursuant to 40 CFR §401.17, the Discharger shall be out of compliance with the pH limitation specified herein if either of the following conditions occur: (i) the total time during which the pH values are outside the required range of pH values exceeds 7 hours and 26 minutes in any calendar month; or (ii) an individual excursion from the range of pH values exceeds 60 minutes.
- (2) This requirement is defined as below the limit of detection of standard test methods (0.05 mg/L), as defined in the latest edition of *Standard Methods for the Examination of Water and Wastewater*. The Discharger may elect to use a continuous on-line monitoring system(s) for measuring flows, sodium hypochlorite, and sodium metabisulfite dosage (including a safety factor) and concentration to prove that chlorine residual exceedances are false positives. If convincing evidence is provided, Regional Water Board staff will conclude that such false positive chlorine residual exceedances are not violations of the effluent limitations established by Order.

2. Effluent Limitations for Toxics Substances

Not Applicable

3. Acute Toxicity

- a. Representative samples of the effluent at Monitoring Location E-001 shall meet the following limits for acute toxicity. Bioassays shall be conducted in compliance with Section V.A of the Monitoring and Reporting Program (MRP, Attachment E).

The survival of organisms in 96-hour static renewal bioassays of undiluted effluent shall be a three (3) sample median value of not less than 90 percent survival, and a single (1) sample value of not less than 70 percent survival.

- b. These acute toxicity limitations are further defined as follows:

3 sample median: A bioassay test showing survival of less than 90 percent represents a violation of this effluent limit, if one of the past two or less bioassay tests also shows less than 90 percent survival.

Single sample limit: A bioassay test showing survival of less than 70 percent represents a violation of this effluent limit.

- c. Bioassays shall be performed using the most up-to-date USEPA protocol and the most sensitive species as specified in writing by the Executive Officer based on the most recent screening test results. Bioassays shall be conducted in compliance with *Methods for Measuring the Acute Toxicity of Effluents and Receiving Water to Freshwater and Marine Organisms*, currently 5th Edition (EPA-821-R-02-012), with exceptions granted to the Discharger by the Executive Officer and the Environmental Laboratory Accreditation Program (ELAP) upon the Discharger's request with justification.
- d. If the Discharger can demonstrate to the satisfaction of the Executive Officer that toxicity exceeding the levels cited above is caused by ammonia and that the ammonia in the discharge is not adversely exceeding effluent limitations, then such toxicity does not constitute a violation of this effluent limitation.

B. Interim Effluent Limitations

Not Applicable

C. Land Discharge Specifications

Not Applicable

D. Reclamation Specifications

Not Applicable

V. RECEIVING WATER LIMITATIONS

A. Surface Water Limitations

1. Receiving water limitations are based on water quality objectives contained in the Basin Plan and are a required part of this Order. The discharges shall not cause the following in the Flood Channel:
- a. Floating, suspended, or deposited macroscopic particulate matter or foams;
 - b. Suspended sediment, dissolved solids, settleable material that results in bottom deposition or aquatic growths to the extent that such deposits or growths cause nuisance or adversely affect beneficial uses;
 - c. Alteration of temperature, turbidity, or apparent color beyond present natural background levels;

- d. Concentrations of taste- or odor-producing substances that impart undesirable tastes or odors to fish flesh or other edible products of aquatic organisms, or otherwise adversely affect beneficial use;
 - e. Visible, floating, suspended, or deposited oil and other products of petroleum origin; and
 - f. Toxic or other deleterious substances to be present in concentrations or quantities which will cause deleterious effects on wildlife, waterfowl, or other aquatic biota, or which render any of these unfit for human consumption, either at levels created in the receiving waters or as a result of biological concentration.
2. The discharge of waste shall not cause the following limits to be exceeded in waters of the State within one foot of the water surface:
- a. Dissolved Oxygen 7.0 mg/L, minimum
The median dissolved oxygen concentration for any three consecutive months shall not be less than 80% of the dissolved oxygen content at saturation. When natural factors cause concentrations less than that specified above, the discharge shall not cause further reduction in ambient dissolved oxygen concentrations.
 - b. Dissolved Sulfide Natural background levels
 - c. pH Within 6.5 and 8.5
 - d. Nutrients Waters shall not contain biostimulatory substances in concentrations that promote aquatic growths to the extent that such growths cause nuisance or adversely affect beneficial uses.

B. Groundwater Limitations

Not Applicable

VI. PROVISIONS

A. Standard Provisions

- 1. **Federal Standard Provisions.** The Discharger shall comply with Federal Standard Provisions included in Attachment D of this Order.
- 2. **Regional Water Board Standard Provisions.** The Discharger shall comply with all applicable items of the *Standard Provisions and Reporting Requirements for NPDES Surface Water Discharge Permits, August 1993* (Attachment G), including any amendments thereto. Where provisions or reporting requirements specified in this Order are different from equivalent or related provisions or reporting requirements given in the Standard Provisions in Attachment D, the specifications of this Order and/or Attachment G shall apply in areas where those provisions are more stringent. Duplicative requirements in the federal Standard Provisions in VI.A.1, above (Attachment D), and the regional Standard Provisions

(Attachment G) are not separate requirements. A violation of a duplicative requirement does not constitute two separate violations.

B. Monitoring and Reporting Program (MRP) Requirements

The Discharger shall comply with the MRP, and future revisions thereto, in Attachment E of this Order. The Discharger shall also comply with the requirements contained in *Self Monitoring Programs, Part A*, August 1993 (Attachment G).

C. Special Provisions

1. Reopener Provisions

The Regional Water Board may modify or reopen this Order prior to its expiration date in any of the following circumstances as allowed by law:

- a. If present or future investigations demonstrate that the discharge(s) governed by this Order will have, or will cease to have, a reasonable potential to cause or contribute to adverse impacts on water quality and/or beneficial uses of the receiving waters.
- b. If new or revised WQOs or TMDLs come into effect for the San Francisco Bay Estuary and contiguous water bodies (whether statewide, regional, or site-specific). In such cases, effluent limitations in this Order will be modified as necessary to reflect updated WQOs and waste load allocations in TMDLs. Adoption of effluent limitations contained in this Order is not intended to restrict in any way future modifications based on legally adopted WQOs, TMDLs, or as otherwise permitted under federal regulations governing NPDES permit modifications.
- c. If translator or other water quality studies provide a basis for determining that a permit condition(s) should be modified.
- d. If an administrative or judicial decision on a separate NPDES permit or WDR that addresses requirements similar to this discharge provides a basis for permit modification.
- e. Or as otherwise authorized by law.

The Discharger may request permit modification based on the above. The Discharger shall include in any such request an antidegradation and antibacksliding analysis.

2. Special Studies, Technical Reports and Additional Monitoring Requirements

a. Effluent Characterization for Selected Constituents

The Discharger shall continue to monitor and evaluate the discharge at Monitoring Location 001 (E-001) for the constituents listed in Enclosure A of the Regional Water Board's August 6, 2001 Letter according to the sampling frequency specified in the attached MRP (Attachment E). Compliance with this requirement shall be achieved in accordance with the specifications stated in the August 6, 2001 Letter under "Effluent Monitoring for Minor Dischargers."

The Discharger shall, on an annual basis, evaluate if concentrations of any constituent increase over past performance. The Discharger shall investigate the cause of the increase. The investigation may include, but need not be limited to, an increase in the effluent monitoring frequency, monitoring of internal process streams, and monitoring of influent sources. This may be satisfied through identification of these constituents as “Pollutants of Concern” in the Discharger’s Pollutant Minimization Program described in Provision C.3.b, below.

The Discharger shall summarize the analytical results of the data collected to date and describe future monitoring to take place, based upon these results, in the annual report required by Part A of the Self-Monitoring Program (Attachment G). The first annual report under this Order is due with the annual Self-Monitoring Report, due February 1 of each year.

A final report that presents all the data shall be submitted to the Regional Water Board no later than 180 days prior to the expiration date of this Order. This final report shall be submitted with the application for permit reissuance. Reporting requirements under this section may be satisfied by (a) monthly reporting using the electronic reporting system (ERS) or an equivalent electronic system required by the Regional Water Board or State Water Board, and (b) submittal of a complete application for permit reissuance no later than 180 days prior to the permit expiration date.

b. Ambient Background Receiving Water Study

The Discharger shall collect background ambient receiving water monitoring data for priority pollutants, as required by section VIII of the MRP (Attachment E), which is required to perform reasonable potential analyses and to calculate effluent limitations. Data collected on the conventional water quality parameters (pH, salinity, and hardness) shall also be sufficient to characterize these parameters in the receiving water at a point after the discharge has mixed with the receiving waters. This Order may be reopened, as appropriate, to incorporate effluent limits or other requirements based on Regional Water Board review of these data.

The Discharger shall submit a final report that presents all the data to the Regional Water Board 180 days prior to Order expiration. This final report shall be submitted with the application for permit reissuance.

The Discharger shall submit a final report that presents all the data to the Regional Water Board 180 days prior to Order expiration. This final report shall be submitted with the application for permit reissuance.

3. Construction, Operation and Maintenance Specifications

a. Wastewater Facilities, Review and Evaluation, and Status Reports

- (1) The Discharger shall operate and maintain its wastewater collection, treatment, and disposal facilities in a manner ensuring that all facilities are adequately staffed, supervised, financed, operated, maintained, repaired, and upgraded as necessary to provide adequate and reliable transport, treatment, and disposal of all wastewater

from both existing and planned future wastewater sources under the Discharger's service responsibilities.

- (2) The Discharger shall regularly review and evaluate its wastewater facilities and operation practices in accordance with section a.(1) above. Reviews and evaluations shall be conducted as an ongoing component of the Discharger's administration of its wastewater facilities.

b. Operations and Maintenance Manual (O&M)

- (1) The Discharger shall maintain an O&M Manual for the Discharger's wastewater facilities. The O&M Manual shall be maintained in usable condition and be available for reference and use by all applicable personnel.
- (2) The Discharger shall regularly review, revise, or update, as necessary, the O&M Manual(s) to ensure that the document(s) may remain useful and relevant to current equipment and operation practices. Reviews shall be conducted annually, and revisions or updates shall be completed as necessary. For any significant changes in treatment facility equipment or operation practices, applicable revisions shall be completed within 90 days of completion of such changes.
- (3) The Discharger shall provide the Executive Officer, upon request, a report describing the current status of its O&M manual, including any recommended or planned actions and an estimated time schedule for these actions. The Discharger shall also include, in each annual self-monitoring report, a description or summary of review and evaluation procedures and applicable changes to its operations and maintenance manual.

c. Contingency Plan

Not Applicable

4. Other Special Provisions

a. Change in Control or Ownership

- (1) In the event of any change in control or ownership of land or waste discharge facilities presently owned or controlled by the Discharger, the Discharger shall notify the succeeding owner or operator of the existence of this Order by letter, a copy of which shall be immediately forwarded to the Regional Water Board.
- (2) To assume responsibility of the facility and operations under this Order, the succeeding owner or operator must apply in writing to the Executive Officer requesting transfer of the Order. Failure to submit the request shall be considered a discharge without requirements, a violation of the California Water Code.

b. Storm Water Requirements

If applicable, the Discharger shall seek coverage under the Statewide Industrial Storm Water Permit (NPDES General Permit No. CAS000001) for Discharges of Storm Water Associated with Industrial Facilities.

VII. COMPLIANCE DETERMINATION

Compliance with the effluent limitations contained in section IV of this Order will be determined as specified below:

A. General.

Compliance with effluent limitations for priority pollutants shall be determined using sample reporting protocols defined in the MRP, Attachment A, and Section VI of the Fact Sheet of this Order. For purposes of reporting and administrative enforcement by the Regional and State Water Boards, the Discharger shall be deemed out of compliance with effluent limitations if the concentration of the priority pollutant in the monitoring sample is greater than the effluent limitation and greater than or equal to the reporting level (RL).

B. Multiple Sample Data.

When determining compliance with an AMEL or MDEL for priority pollutants and more than one sample result is available, the Discharger shall compute the arithmetic mean unless the data set contains one or more reported determinations of “Detected, but Not Quantified” (DNQ) or “Not Detected” (ND). In those cases, the Discharger shall compute the median in place of the arithmetic mean in accordance with the following procedure:

1. The data set shall be ranked from low to high, ranking the reported ND determinations lowest, DNQ determinations next, followed by quantified values (if any). The order of the individual ND or DNQ determinations is unimportant.
2. The median value of the data set shall be determined. If the data set has an odd number of data points, then the median is the middle value. If the data set has an even number of data points, then the median is the average of the two values around the middle unless one or both of the points are ND or DNQ, in which case the median value shall be the lower of the two data points where DNQ is lower than a value and ND is lower than DNQ.

ATTACHMENT A – DEFINITIONS

Arithmetic Mean (μ), also called the average, is the sum of measured values divided by the number of samples. For ambient water concentrations, the arithmetic mean is calculated as follows:

$$\text{Arithmetic mean} = \mu = \Sigma x / n$$

where:

Σx is the sum of the measured ambient water concentrations; and
 n is the number of samples.

Average Monthly Effluent Limitation (AMEL) is the highest allowable average of daily discharges over a calendar month, calculated as the sum of all daily discharges measured during a calendar month divided by the number of daily discharges measured during that month.

Average Weekly Effluent Limitation (AWEL) is the highest allowable average of daily discharges over a calendar week (Sunday through Saturday), calculated as the sum of all daily discharges measured during a calendar week divided by the number of daily discharges measured during that week.

Bioaccumulative pollutants are those substances taken up by an organism from its surrounding medium through gill membranes, epithelial tissue, or from food and subsequently concentrated and retained in the body of the organism.

Carcinogenic pollutants are substances that are known to cause cancer in living organisms.

Coefficient of Variation (CV) is a measure of the data variability and is calculated as the estimated standard deviation divided by the arithmetic mean of the observed values.

Daily Discharge is defined as either: (1) the total mass of the constituent discharged over the calendar day (12:00 am through 11:59 pm) or any 24-hour period that reasonably represents a calendar day for purposes of sampling (as specified in the Order), for a constituent with limitations expressed in units of mass or; (2) the unweighted arithmetic mean measurement of the constituent over the day for a constituent with limitations expressed in other units of measurement (e.g., concentration).

The daily discharge may be determined by the analytical results of a composite sample taken over the course of one day (a calendar day or other 24-hour period defined as a day) or by the arithmetic mean of analytical results from one or more grab samples taken over the course of the day.

For composite sampling, if 1 day is defined as a 24-hour period other than a calendar day, the analytical result for the 24-hour period will be considered as the result for the calendar day in which the 24-hour period ends.

Detected, but Not Quantified (DNQ) are those sample results less than the RL, but greater than or equal to the laboratory's MDL.

Dilution Credit is the amount of dilution granted to a discharge in the calculation of a water quality-based effluent limitation, based on the allowance of a specified mixing zone. It is calculated from the dilution ratio or determined through conducting a mixing zone study or modeling of the discharge and receiving water.

Effluent Concentration Allowance (ECA) is a value derived from the water quality criterion/objective, dilution credit, and ambient background concentration that is used, in conjunction with the coefficient of variation for the effluent monitoring data, to calculate a long-term average (LTA) discharge concentration. The ECA has the same meaning as waste load allocation (WLA) as used in USEPA guidance (Technical Support Document For Water Quality-based Toxics Control, March 1991, second printing, EPA/505/2-90-001).

Enclosed Bays are indentations along the coast that enclose an area of oceanic water within distinct headlands or harbor works. Enclosed bays include all bays where the narrowest distance between the headlands or outermost harbor works is less than 75 percent of the greatest dimension of the enclosed portion of the bay. Enclosed bays include, but are not limited to, Humboldt Bay, Bodega Harbor, Tomales Bay, Drake's Estero, San Francisco Bay, Morro Bay, Los Angeles-Long Beach Harbor, Upper and Lower Newport Bay, Mission Bay, and San Diego Bay. Enclosed bays do not include inland surface waters or ocean waters.

Estimated Chemical Concentration is the estimated chemical concentration that results from the confirmed detection of the substance by the analytical method below the ML value.

Estuaries means waters, including coastal lagoons, located at the mouths of streams that serve as areas of mixing for fresh and ocean waters. Coastal lagoons and mouths of streams that are temporarily separated from the ocean by sandbars shall be considered estuaries. Estuarine waters shall be considered to extend from a bay or the open ocean to a point upstream where there is no significant mixing of fresh water and seawater. Estuarine waters include, but are not limited to, the Sacramento-San Joaquin Delta, as defined in Water Code section 12220, Suisun Bay, Carquinez Strait downstream to the Carquinez Bridge, and appropriate areas of the Smith, Mad, Eel, Noyo, Russian, Klamath, San Diego, and Otay rivers. Estuaries do not include inland surface waters or ocean waters.

Inland Surface Waters are all surface waters of the State that do not include the ocean, enclosed bays, or estuaries.

Instantaneous Maximum Effluent Limitation is the highest allowable value for any single grab sample or aliquot (i.e., each grab sample or aliquot is independently compared to the instantaneous maximum limitation).

Instantaneous Minimum Effluent Limitation is the lowest allowable value for any single grab sample or aliquot (i.e., each grab sample or aliquot is independently compared to the instantaneous minimum limitation).

Maximum Daily Effluent Limitation (MDEL) is the highest allowable daily discharge of a pollutant, over a calendar day (or 24-hour period). For pollutants with limitations expressed in units of mass, the daily discharge is calculated as the total mass of the pollutant discharged over the day. For pollutants with limitations expressed in other units of measurement, the daily discharge is calculated as the arithmetic mean measurement of the pollutant over the day.

Median is the middle measurement in a set of data. The median of a set of data is found by first arranging the measurements in order of magnitude (either increasing or decreasing order). If the number of measurements (n) is odd, then the median = $X_{(n+1)/2}$. If n is even, then the median = $(X_{n/2} + X_{(n/2)+1})/2$ (i.e., the midpoint between the $n/2$ and $n/2+1$).

Method Detection Limit (MDL) is the minimum concentration of a substance that can be measured and reported with 99 percent confidence that the analyte concentration is greater than zero, as defined in title 40 of the Code of Federal Regulations, Part 136, Attachment B, revised as of July 3, 1999.

Minimum Level (ML) is the concentration at which the entire analytical system must give a recognizable signal and acceptable calibration point. The ML is the concentration in a sample that is equivalent to the concentration of the lowest calibration standard analyzed by a specific analytical procedure, assuming that all the method specified sample weights, volumes, and processing steps have been followed.

Mixing Zone is a limited volume of receiving water that is allocated for mixing with a wastewater discharge where water quality criteria can be exceeded without causing adverse effects to the overall water body.

Not Detected (ND) are those sample results less than the laboratory's MDL.

Ocean Waters are the territorial marine waters of the State as defined by California law to the extent these waters are outside of enclosed bays, estuaries, and coastal lagoons. Discharges to ocean waters are regulated in accordance with the State Water Board's California Ocean Plan.

Persistent pollutants are substances for which degradation or decomposition in the environment is nonexistent or very slow.

Pollutant Minimization Program (PMP) is a waste minimization and pollution prevention action that includes, but is not limited to, product substitution, waste stream recycling, alternative waste management methods, and education of the public and businesses. The goal of the PMP shall be to reduce all potential sources of a priority pollutant(s) through pollutant minimization (control) strategies, including pollution prevention measures as appropriate, to maintain the effluent concentration at or below the water quality-based effluent limitation. Pollution prevention measures may be particularly appropriate for persistent bioaccumulative priority pollutants where there is evidence that beneficial uses are being impacted. The Regional Water Board may consider cost effectiveness when establishing the requirements of a PMP. The completion and implementation of a Pollution Prevention Plan, if required pursuant to Water Code section 13263.3(d), shall be considered to fulfill the PMP requirements.

Pollution Prevention is any action that causes a net reduction in the use or generation of a hazardous substance or other pollutant that is discharged into water and includes, but is not limited to, input change, operational improvement, production process change, and product reformulation (as defined in Water Code section 13263.3). Pollution prevention does not include actions that merely shift a pollutant in wastewater from one environmental medium to another environmental medium, unless clear environmental benefits of such an approach are identified to the satisfaction of the State or Regional Water Board.

Reporting Level (RL) is the ML (and its associated analytical method) chosen by the Discharger for reporting and compliance determination from the MLs included in this Order. The MLs included in this Order correspond to approved analytical methods for reporting a sample result that are selected by the Regional Water Board either from Appendix 4 of the SIP in accordance with section 2.4.2 of the SIP or established in accordance with section 2.4.3 of the SIP. The ML is based on the proper application of method-based analytical procedures for sample preparation and the absence of any matrix interferences. Other factors may be applied to the ML depending on the specific sample preparation steps employed.

For example, the treatment typically applied in cases where there are matrix-effects is to dilute the sample or sample aliquot by a factor of ten. In such cases, this additional factor must be applied to the ML in the computation of the RL.

Satellite Collection System is the portion, if any, of a sanitary sewer system owned or operated by a different public agency than the agency that owns and operates the wastewater treatment facility that a sanitary sewer system is tributary to.

Source of Drinking Water is any water designated as municipal or domestic supply (MUN) in a Regional Water Board Basin Plan.

Standard Deviation (σ) is a measure of variability that is calculated as follows:

$$\sigma = (\sum[(x - \mu)^2]/(n - 1))^{0.5}$$

where:

x is the observed value;

μ is the arithmetic mean of the observed values; and

n is the number of samples.

Toxicity Reduction Evaluation (TRE) is a study conducted in a step-wise process designed to identify the causative agents of effluent or ambient toxicity, isolate the sources of toxicity, evaluate the effectiveness of toxicity control options, and then confirm the reduction in toxicity. The first steps of the TRE consist of the collection of data relevant to the toxicity, including additional toxicity testing, and an evaluation of facility operations and maintenance practices, and best management practices. A Toxicity Identification Evaluation (TIE) may be required as part of the TRE, if appropriate. (A TIE is a set of procedures to identify the specific chemical(s) responsible for toxicity. These procedures are performed in three phases (characterization, identification, and confirmation) using aquatic organism toxicity tests.)

ATTACHMENT B – FACILITY MAP

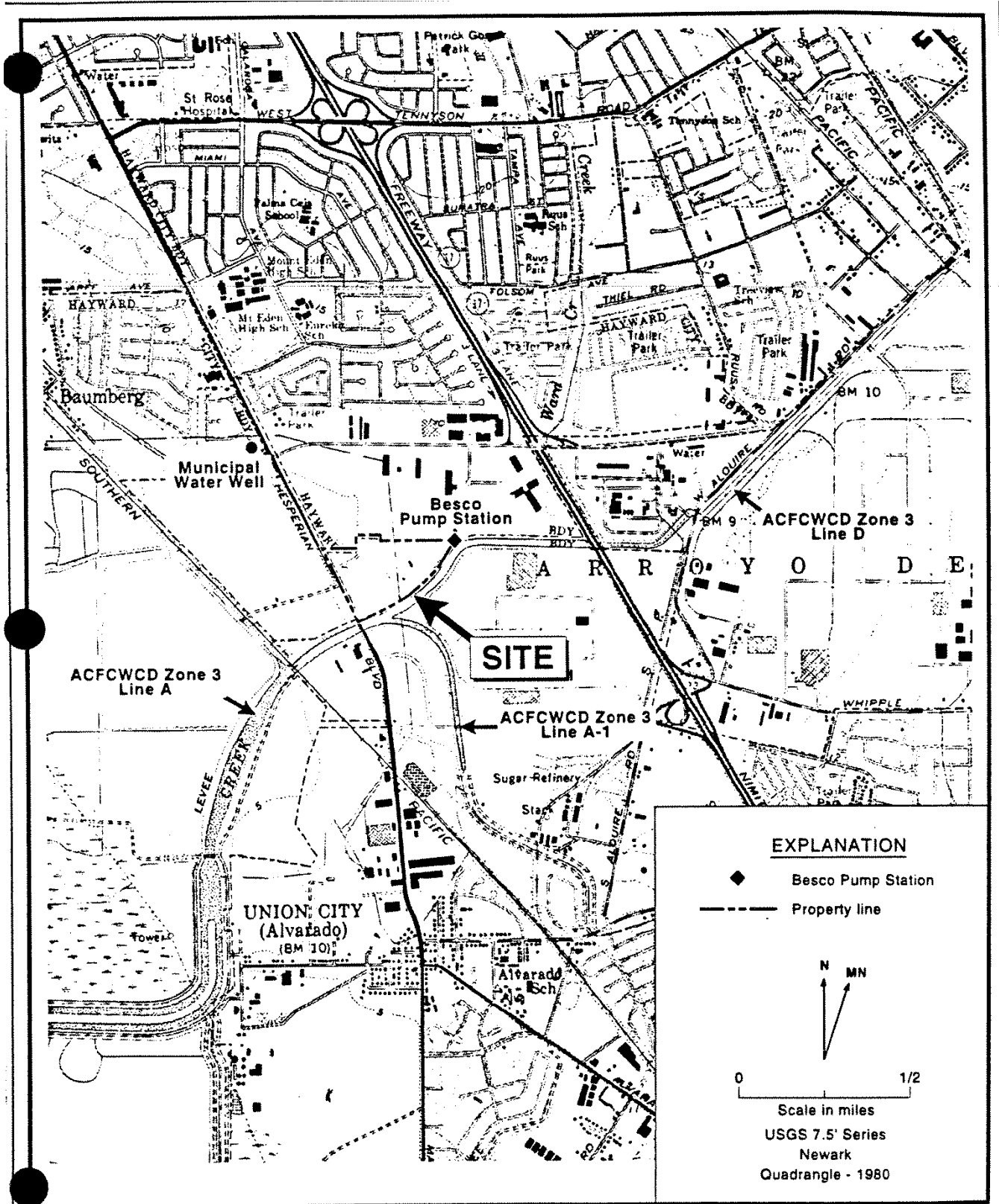

ATTACHMENT C – PROCESS FLOW DIAGRAM

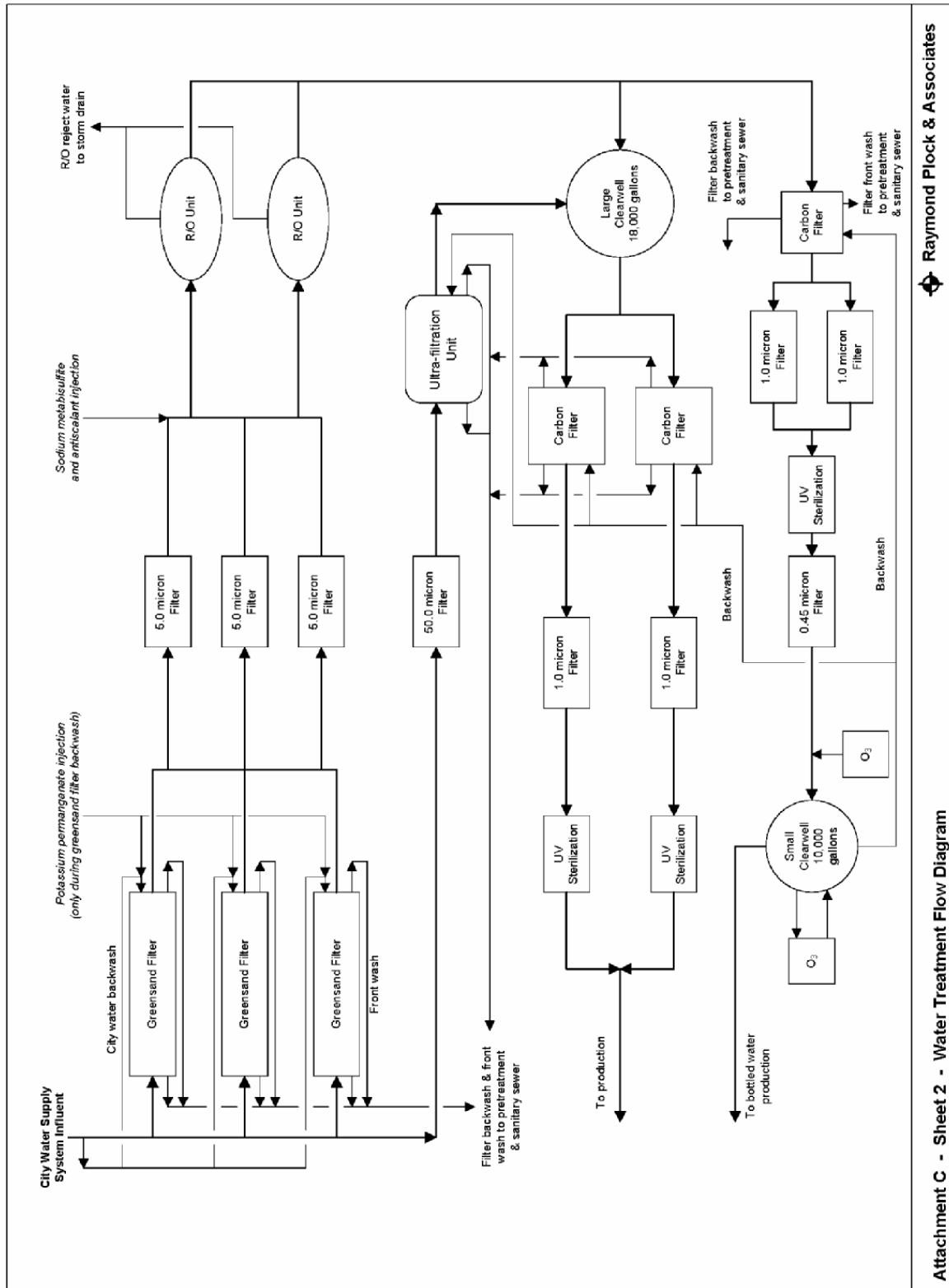

Raymond Plock & Associates

Attachment C - Sheet 2 - Water Treatment Flow Diagram

1208804

Permit No. 96-1524-03-2FP

Hay11275d

ATTACHMENT D –STANDARD PROVISIONS

I. STANDARD PROVISIONS – PERMIT COMPLIANCE

A. Duty to Comply

1. The Discharger must comply with all of the conditions of this Order. Any noncompliance constitutes a violation of the Clean Water Act (CWA) and the California Water Code and is grounds for enforcement action, for permit termination, revocation and reissuance, or modification; or denial of a permit renewal application. (40 CFR §122.41(a).)
2. The Discharger shall comply with effluent standards or prohibitions established under Section 307(a) of the CWA for toxic pollutants and with standards for sewage sludge use or disposal established under Section 405(d) of the CWA within the time provided in the regulations that establish these standards or prohibitions, even if this Order has not yet been modified to incorporate the requirement. (40 CFR §122.41(a)(1).)

B. Need to Halt or Reduce Activity Not a Defense

It shall not be a defense for a Discharger in an enforcement action that it would have been necessary to halt or reduce the permitted activity in order to maintain compliance with the conditions of this Order. (40 CFR §122.41(c).)

C. Duty to Mitigate

The Discharger shall take all reasonable steps to minimize or prevent any discharge or sludge use or disposal in violation of this Order that has a reasonable likelihood of adversely affecting human health or the environment. (40 CFR §122.41(d).)

D. Proper Operation and Maintenance

The Discharger shall at all times properly operate and maintain all facilities and systems of treatment and control (and related appurtenances) which are installed or used by the Discharger to achieve compliance with the conditions of this Order. Proper operation and maintenance also includes adequate laboratory controls and appropriate quality assurance procedures. This provision requires the operation of backup or auxiliary facilities or similar systems that are installed by a Discharger only when necessary to achieve compliance with the conditions of this Order (40 CFR §122.41(e)).

E. Property Rights

1. This Order does not convey any property rights of any sort or any exclusive privileges. (40 CFR §122.41(g).)
2. The issuance of this Order does not authorize any injury to persons or property or invasion of other private rights, or any infringement of state or local law or regulations. (40 CFR §122.5(c).)

F. Inspection and Entry

The Discharger shall allow the Regional Water Board, State Water Board, United States Environmental Protection Agency (USEPA), and/or their authorized representatives (including an authorized contractor acting as their representative), upon the presentation of credentials and other documents, as may be required by law, to (40 CFR §122.41(i); Water Code, §13383):

1. Enter upon the Discharger's premises where a regulated facility or activity is located or conducted, or where records are kept under the conditions of this Order (40 CFR §122.41(i)(1));
2. Have access to and copy, at reasonable times, any records that must be kept under the conditions of this Order (40 CFR §122.41(i)(2));
3. Inspect and photograph, at reasonable times, any facilities, equipment (including monitoring and control equipment), practices, or operations regulated or required under this Order (40 CFR §122.41(i)(3)); and
4. Sample or monitor, at reasonable times, for the purposes of assuring Order compliance or as otherwise authorized by the CWA or the Water Code, any substances or parameters at any location. (40 CFR §122.41(i)(4).)

G. Bypass

1. Definitions
 - a. "Bypass" means the intentional diversion of waste streams from any portion of a treatment facility. (40 CFR §122.41(m)(1)(i).)
 - b. "Severe property damage" means substantial physical damage to property, damage to the treatment facilities, which causes them to become inoperable, or substantial and permanent loss of natural resources that can reasonably be expected to occur in the absence of a bypass. Severe property damage does not mean economic loss caused by delays in production. (40 CFR §122.41(m)(1)(ii).)
2. Bypass not exceeding limitations. The Discharger may allow any bypass to occur which does not cause exceedances of effluent limitations, but only if it is for essential maintenance to assure efficient operation. These bypasses are not subject to the provisions listed in Standard Provisions – Permit Compliance I.G.3, I.G.4, and I.G.5 below. (40 CFR §122.41(m)(2).)
3. Prohibition of bypass. Bypass is prohibited, and the Regional Water Board may take enforcement action against a Discharger for bypass, unless (40 CFR §122.41(m)(4)(i)):
 - a. Bypass was unavoidable to prevent loss of life, personal injury, or severe property damage (40 CFR §122.41(m)(4)(i)(A));
 - b. There were no feasible alternatives to the bypass, such as the use of auxiliary treatment facilities, retention of untreated wastes, or maintenance during normal periods of equipment downtime. This condition is not satisfied if adequate back-up equipment

should have been installed in the exercise of reasonable engineering judgment to prevent a bypass that occurred during normal periods of equipment downtime or preventive maintenance (40 CFR §122.41(m)(4)(i)(B)); and

- c. The Discharger submitted notice to the Regional Water Board as required under Standard Provisions – Permit Compliance I.G.5 below. (40 CFR §122.41(m)(4)(i)(C).)
4. The Regional Water Board may approve an anticipated bypass, after considering its adverse effects, if the Regional Water Board determines that it will meet the three conditions listed in Standard Provisions – Permit Compliance I.G.3 above. (40 CFR §122.41(m)(4)(ii).)
5. Notice
 - a. Anticipated bypass. If the Discharger knows in advance of the need for a bypass, it shall submit a notice, if possible at least 10 days before the date of the bypass. (40 CFR §122.41(m)(3)(i).)
 - b. Unanticipated bypass. The Discharger shall submit notice of an unanticipated bypass as required in Standard Provisions - Reporting V.E below (24-hour notice). (40 CFR §122.41(m)(3)(ii).)

H. Upset

Upset means an exceptional incident in which there is unintentional and temporary noncompliance with technology based permit effluent limitations because of factors beyond the reasonable control of the Discharger. An upset does not include noncompliance to the extent caused by operational error, improperly designed treatment facilities, inadequate treatment facilities, lack of preventive maintenance, or careless or improper operation. (40 CFR §122.41(n)(1).)

1. Effect of an upset. An upset constitutes an affirmative defense to an action brought for noncompliance with such technology based permit effluent limitations if the requirements of Standard Provisions – Permit Compliance I.H.2 below are met. No determination made during administrative review of claims that noncompliance was caused by upset, and before an action for noncompliance, is final administrative action subject to judicial review. (40 CFR §122.41(n)(2).)
2. Conditions necessary for a demonstration of upset. A Discharger who wishes to establish the affirmative defense of upset shall demonstrate, through properly signed, contemporaneous operating logs or other relevant evidence that (40 CFR §122.41(n)(3)):
 - a. An upset occurred and that the Discharger can identify the cause(s) of the upset (40 CFR §122.41(n)(3)(i));
 - b. The permitted facility was, at the time, being properly operated (40 CFR §122.41(n)(3)(ii));
 - c. The Discharger submitted notice of the upset as required in Standard Provisions – Reporting V.E.2.b below (24-hour notice) (40 CFR §122.41(n)(3)(iii)); and

- d. The Discharger complied with any remedial measures required under Standard Provisions – Permit Compliance I.C above. (40 CFR §122.41(n)(3)(iv).)
3. Burden of proof. In any enforcement proceeding, the Discharger seeking to establish the occurrence of an upset has the burden of proof. (40 CFR §122.41(n)(4).)

II. STANDARD PROVISIONS – PERMIT ACTION

A. General

This Order may be modified, revoked and reissued, or terminated for cause. The filing of a request by the Discharger for modification, revocation and reissuance, or termination, or a notification of planned changes or anticipated noncompliance does not stay any Order condition. (40 CFR §122.41(f).)

B. Duty to Reapply

If the Discharger wishes to continue an activity regulated by this Order after the expiration date of this Order, the Discharger must apply for and obtain a new permit. (40 CFR §122.41(b).)

C. Transfers

This Order is not transferable to any person except after notice to the Regional Water Board. The Regional Water Board may require modification or revocation and reissuance of this Order to change the name of the Discharger and incorporate such other requirements as may be necessary under the CWA and the Water Code. (40 CFR §122.41(l)(3); §122.61.)

III. STANDARD PROVISIONS – MONITORING

- A. Samples and measurements taken for the purpose of monitoring shall be representative of the monitored activity. (40 CFR §122.41(j)(1).)
- B. Monitoring results must be conducted according to test procedures under Part 136 or, in the case of sludge use or disposal, approved under Part 136 unless otherwise specified in Part 503 unless other test procedures have been specified in this Order. (40 CFR §122.41(j)(4); §122.44(i)(1)(iv).)

IV. STANDARD PROVISIONS – RECORDS

- A. Except for records of monitoring information required by this Order related to the Discharger's sewage sludge use and disposal activities, which shall be retained for a period of at least five years (or longer as required by Part 503), the Discharger shall retain records of all monitoring information, including all calibration and maintenance records and all original strip chart recordings for continuous monitoring instrumentation, copies of all reports required by this Order, and records of all data used to complete the application for this Order, for a period of at least three (3) years from the date of the sample, measurement, report or application. This period may be extended by request of the Regional Water Board Executive Officer at any time. (40 CFR §122.41(j)(2).)
- B. Records of monitoring information shall include:
 1. The date, exact place, and time of sampling or measurements (40 CFR §122.41(j)(3)(i));

2. The individual(s) who performed the sampling or measurements (40 CFR §122.41(j)(3)(ii));
3. The date(s) analyses were performed (40 CFR §122.41(j)(3)(iii));
4. The individual(s) who performed the analyses (40 CFR §122.41(j)(3)(iv));
5. The analytical techniques or methods used (40 CFR §122.41(j)(3)(v)); and
6. The results of such analyses. (40 CFR §122.41(j)(3)(vi).)

C. Claims of confidentiality for the following information will be denied (40 CFR §122.7(b)):

1. The name and address of any permit applicant or Discharger (40 CFR §122.7(b)(1)); and
2. Permit applications and attachments, permits and effluent data. (40 CFR §122.7(b)(2).)

V. STANDARD PROVISIONS – REPORTING

A. Duty to Provide Information

The Discharger shall furnish to the Regional Water Board, State Water Board, or USEPA within a reasonable time, any information which the Regional Water Board, State Water Board, or USEPA may request to determine whether cause exists for modifying, revoking and reissuing, or terminating this Order or to determine compliance with this Order. Upon request, the Discharger shall also furnish to the Regional Water Board, State Water Board, or USEPA copies of records required to be kept by this Order. (40 CFR §122.41(h); Water Code, §13267.)

B. Signatory and Certification Requirements

1. All applications, reports, or information submitted to the Regional Water Board, State Water Board, and/or USEPA shall be signed and certified in accordance with Standard Provisions – Reporting V.B.2, V.B.3, V.B.4, and V.B.5 below. (40 CFR §122.41(k).)
2. All permit applications shall be signed by a responsible corporate officer. For purposes of this section, a responsible corporate officer means: (i) A president, secretary, treasurer, or vice-president of the corporation in charge of a principal business function, or any other person who performs similar policy- or decision- making functions for the corporation, or (ii) the manager of one or more manufacturing, production, or operating facilities, provided, the manager is authorized to make management decisions which govern the operation of the regulated facility including having the explicit or implicit duty of making major capital investment recommendations, and initiating and directing other comprehensive measures to assure long term environmental compliance with environmental laws and regulations; the manager can ensure that the necessary systems are established or actions taken to gather complete and accurate information for permit application requirements; and where authority to sign documents has been assigned or delegated to the manager in accordance with corporate procedures. (40 CFR §122.22(a)(1).)
3. All reports required by this Order and other information requested by the Regional Water Board, State Water Board, or USEPA shall be signed by a person described in Standard

Provisions – Reporting V.B.2 above, or by a duly authorized representative of that person. A person is a duly authorized representative only if:

- a. The authorization is made in writing by a person described in Standard Provisions – Reporting V.B.2 above (40 CFR §122.22(b)(1));
 - b. The authorization specifies either an individual or a position having responsibility for the overall operation of the regulated facility or activity such as the position of plant manager, operator of a well or a well field, superintendent, position of equivalent responsibility, or an individual or position having overall responsibility for environmental matters for the company. (A duly authorized representative may thus be either a named individual or any individual occupying a named position.) (40 CFR §122.22(b)(2)); and
 - c. The written authorization is submitted to the Regional Water Board and State Water Board. (40 CFR §122.22(b)(3).)
4. If an authorization under Standard Provisions – Reporting V.B.3 above is no longer accurate because a different individual or position has responsibility for the overall operation of the facility, a new authorization satisfying the requirements of Standard Provisions – Reporting V.B.3 above must be submitted to the Regional Water Board and State Water Board prior to or together with any reports, information, or applications, to be signed by an authorized representative. (40 CFR §122.22(c).)
5. Any person signing a document under Standard Provisions – Reporting V.B.2 or V.B.3 above shall make the following certification:

“I certify under penalty of law that this document and all attachments were prepared under my direction or supervision in accordance with a system designed to assure that qualified personnel properly gather and evaluate the information submitted. Based on my inquiry of the person or persons who manage the system or those persons directly responsible for gathering the information, the information submitted is, to the best of my knowledge and belief, true, accurate, and complete. I am aware that there are significant penalties for submitting false information, including the possibility of fine and imprisonment for knowing violations.” (40 CFR §122.22(d).)

C. Monitoring Reports

1. Monitoring results shall be reported at the intervals specified in the Monitoring and Reporting Program (Attachment E) in this Order. (40 CFR §122.22(l)(4).)
2. Monitoring results must be reported on a Discharge Monitoring Report (DMR) form or forms provided or specified by the Regional Water Board or State Water Board for reporting results of monitoring of sludge use or disposal practices. (40 CFR §122.41(l)(4)(i).)
3. If the Discharger monitors any pollutant more frequently than required by this Order using test procedures approved under Part 136 or, in the case of sludge use or disposal, approved under Part 136 unless otherwise specified in Part 503, or as specified in this Order, the results of this monitoring shall be included in the calculation and reporting of the data submitted in

the DMR or sludge reporting form specified by the Regional Water Board. (40 CFR §122.41(l)(4)(ii).)

4. Calculations for all limitations, which require averaging of measurements, shall utilize an arithmetic mean unless otherwise specified in this Order. (40 CFR §122.41(l)(4)(iii).)

D. Compliance Schedules

Reports of compliance or noncompliance with, or any progress reports on, interim and final requirements contained in any compliance schedule of this Order, shall be submitted no later than 14 days following each schedule date. (40 CFR §122.41(l)(5).)

E. Twenty-Four Hour Reporting

1. The Discharger shall report any noncompliance that may endanger health or the environment. Any information shall be provided orally within 24 hours from the time the Discharger becomes aware of the circumstances. A written submission shall also be provided within five (5) days of the time the Discharger becomes aware of the circumstances. The written submission shall contain a description of the noncompliance and its cause; the period of noncompliance, including exact dates and times, and if the noncompliance has not been corrected, the anticipated time it is expected to continue; and steps taken or planned to reduce, eliminate, and prevent reoccurrence of the noncompliance. (40 CFR §122.41(l)(6)(i).)
2. The following shall be included as information that must be reported within 24 hours under this paragraph (40 CFR §122.41(l)(6)(ii)):
 - a. Any unanticipated bypass that exceeds any effluent limitation in this Order. (40 CFR §122.41(l)(6)(ii)(A).)
 - b. Any upset that exceeds any effluent limitation in this Order. (40 CFR §122.41(l)(6)(ii)(B).)
3. The Regional Water Board may waive the above-required written report under this provision on a case-by-case basis if an oral report has been received within 24 hours. (40 CFR §122.41(l)(6)(iii).)

F. Planned Changes

The Discharger shall give notice to the Regional Water Board as soon as possible of any planned physical alterations or additions to the permitted facility. Notice is required under this provision only when (40 CFR §122.41(l)(1)):

1. The alteration or addition to a permitted facility may meet one of the criteria for determining whether a facility is a new source in section 122.29(b) (40 CFR §122.41(l)(1)(i)); or
2. The alteration or addition could significantly change the nature or increase the quantity of pollutants discharged. This notification applies to pollutants that are not subject neither to effluent limitations in this Order not to notification requirements under section 122.42(a)(1) (see Additional Provisions – Notification Levels VII.A.1). (40 CFR §122.41(l)(1)(ii).)

3. The alteration or addition results in a significant change in the Discharger's sludge use or disposal practices, and such alteration, addition, or change may justify the application of permit conditions that are different from or absent in the existing permit, including notification of additional use or disposal sites not reported during the permit application process or not reported pursuant to an approved land application plan. (40 C.F.R. §122.41(l)(1)(iii).)

G. Anticipated Noncompliance

The Discharger shall give advance notice to the Regional Water Board or State Water Board of any planned changes in the permitted facility or activity that may result in noncompliance with General Order requirements. (40 CFR §122.41(l)(2).)

H. Other Noncompliance

The Discharger shall report all instances of noncompliance not reported under Standard Provisions – Reporting V.C, V.D, and V.E above at the time monitoring reports are submitted. The reports shall contain the information listed in Standard Provision – Reporting V.E above. (40 CFR §122.41(l)(7).)

I. Other Information

When the Discharger becomes aware that it failed to submit any relevant facts in a permit application, or submitted incorrect information in a permit application or in any report to the Regional Water Board, State Water Board, or USEPA, the Discharger shall promptly submit such facts or information. (40 CFR §122.41(l)(8).)

VI. STANDARD PROVISIONS – ENFORCEMENT

- A. The Regional Water Board is authorized to enforce the terms of this Order under several provisions of the Water Code, including, but not limited to, sections 13385, 13386, and 13387.

VII. ADDITIONAL PROVISIONS – NOTIFICATION LEVELS

A. Non-Municipal Facilities

Existing manufacturing, commercial, mining, and silvicultural Dischargers shall notify the Regional Water Board as soon as they know or have reason to believe (40 CFR §122.42(a)):

1. That any activity has occurred or will occur that would result in the discharge, on a routine or frequent basis, of any toxic pollutant that is not limited in this Order, if that discharge will exceed the highest of the following "notification levels" (40 CFR §122.42(a)(1)):
 - a. 100 micrograms per liter ($\mu\text{g/L}$) (40 CFR §122.42(a)(1)(i));
 - b. 200 $\mu\text{g/L}$ for acrolein and acrylonitrile; 500 $\mu\text{g/L}$ for 2,4-dinitrophenol and 2-methyl-4,6-dinitrophenol; and 1 milligram per liter (mg/L) for antimony (40 CFR §122.42(a)(1)(ii));

- c.** Five (5) times the maximum concentration value reported for that pollutant in the Report of Waste Discharge (40 CFR §122.42(a)(1)(iii)); or
 - d.** The level established by the Regional Water Board in accordance with section 122.44(f). (40 CFR §122.42(a)(1)(iv).)
- 2.** That any activity has occurred or will occur that would result in the discharge, on a non-routine or infrequent basis, of any toxic pollutant that is not limited in this Order, if that discharge will exceed the highest of the following “notification levels” (40 CFR §122.42(a)(2)):
 - a.** 500 micrograms per liter ($\mu\text{g/L}$) (40 CFR §122.42(a)(2)(i));
 - b.** 1 milligram per liter (mg/L) for antimony (40 CFR §122.42(a)(2)(ii));
 - c.** Ten (10) times the maximum concentration value reported for that pollutant in the Report of Waste Discharge (40 CFR §122.42(a)(2)(iii)); or
 - d.** The level established by the Regional Water Board in accordance with section 122.44(f). (40 CFR §122.42(a)(2)(iv).)

ATTACHMENT E – MONITORING AND REPORTING PROGRAM

Table of Contents

I.	General Monitoring Provisions.....	E-2
II.	Monitoring Locations.....	E-2
III.	Influent Monitoring Requirements	E-3
	A. Monitoring Location I-001	E-3
IV.	Effluent Monitoring Requirements.....	E-3
	A. Monitoring Location – E-001	E-3
	B. Monitoring Location – E-001a	E-4
V.	Whole Effluent Toxicity Testing Requirements.....	E-5
VI.	Land Discharge Monitoring Requirements.....	E-5
VII.	Reclamation Monitoring Requirements.....	E-5
VIII.	Receiving Water Monitoring Requirements – Surface water and Groundwater	E-6
	A. Monitoring Locations – R-001, R-002	E-6
IX.	Legend for MRP Tables.....	E-7
X.	Modifications to Part A of Self-Monitoring Program (Attachment G)	E-7
	A. Self-Monitoring Program Part A	E-7
XI.	Reporting Requirements	E-11
	A. General Monitoring and Reporting Requirements	E-11
	B. Self Monitoring Reports (SMRs)	E-11
	C. Discharge Monitoring Reports (DMRs).....	E-13
	D. Other Reports	E-13

Tables

Table E-1.	Monitoring Station Locations	E-3
Table E-2.	Influent Monitoring Requirements – I-001	E-3
Table E-3.	Effluent Monitoring – E-001.....	E-4
Table E-4.	Effluent Monitoring – E-001a.....	E-5
Table E-5.	Receiving Water Monitoring – R-001	E-6
Table E-6.	Receiving Water Monitoring – R-002	E-6
Table E-7.	Monitoring Periods and Reporting Schedule.....	E-11

ATTACHMENT E – MONITORING AND REPORTING PROGRAM (MRP)

NPDES regulations at 40 CFR §122.48 require that all NPDES permits specify monitoring and reporting requirements. Water Code sections 13267 and 13383 also authorize the Regional Water Quality Control Board (Regional Water Board) to require technical and monitoring reports. This MRP establishes monitoring and reporting requirements that implement the federal and California regulations.

I. GENERAL MONITORING PROVISIONS

- A.** The Discharger shall comply with the MRP for this Order as adopted by the Regional Water Board, and with all of Self-Monitoring Program, Part A, adopted August 1993 (SMP). The MRP and SMP may be amended by the Executive Officer pursuant to USEPA regulations 40 CFR §122.62, §122.63, and §124.5. If any discrepancies exist between the MRP and SMP, the MRP prevails.
- B.** Sampling is required during the entire year when discharging. All analyses shall be conducted using current USEPA methods, or methods that have been approved by the USEPA Regional Administrator pursuant to 40 CFR §136.4 and 40 CFR §136.5, or equivalent methods that are commercially and reasonably available and that provide quantification of sampling parameters and constituents sufficient to evaluate compliance with applicable effluent limits and to perform reasonable potential analyses. Equivalent methods must be more sensitive than those specified in 40 CFR §136, must be specified in the permit, and must be approved for use by the Executive Officer following consultation with the State Water Quality Control Board's Quality Assurance Program.
- C.** Sampling and analysis of additional constituents is required pursuant to Table 1 of the Regional Water Board's August 6, 2001 Letter entitled, *Requirement for Monitoring of Pollutants in Effluent and Receiving Water to Implement New Statewide Regulations and Policy* (Attachment G).
- D. Minimum Levels.** For compliance and reasonable potential monitoring, analyses shall be conducted using the commercially available and reasonably achievable detection levels that are lower than applicable water quality objectives or criteria, or the effluent limitations, whichever are lower. The objective is to provide quantification of constituents sufficient to allow evaluation of observed concentrations with respect to the Minimum Levels (MLs). All MLs are expressed in µg/L, approximately equal to parts per billion (ppb).

II. MONITORING LOCATIONS

The Discharger shall establish the following monitoring locations to demonstrate compliance with the effluent limitations, discharge specifications, and other requirements in this Order:

Table E-1. Monitoring Station Locations

Waste Stream	Monitoring Location Name	Monitoring Location Description
Influent	I-001	At any point in the pipe which delivers potable water to the reverse osmosis plant, prior to any point of use. If more than one pipe delivers raw water, the influent sample shall consist of a flow-proportioned composite from each source.
Effluent	E-001	At any point in the outfall between the point of discharge and the point at which all wastes tributary to the discharge are present.
Effluent	E-001a	At any point in the 12,000 gallon storm-water interceptor or the downstream adjacent outlet box.
Receiving Water	R-001	At any point in the receiving water immediately upstream of the point of discharge.
Receiving Water	R-002	At any point in the receiving water within 100 feet downstream of the point of discharge.

III. INFLUENT MONITORING REQUIREMENTS

A. Monitoring Location I-001

The Discharger shall monitor potable water intake to the facility at I-001 as follows:

Table E-2. Influent Monitoring Requirements – I-001

Parameter	Units	Sample Type	Minimum Sampling Frequency
Flow Rate ⁽¹⁾	mgd	Continuous	Daily
Sodium Metabisulfite ⁽²⁾	NA	Observations	Daily

Footnotes for Table E-2:

- (1) For influent flows, flow monitoring shall be measured continuously and recorded daily, except on weekends and holidays, when the Discharger’s facility has limited staff to take measurements. During these periods, the average daily flow volume may be calculated by dividing the total flow volume for the period by the number of days of the period. The Discharger shall note when reporting these values that they are averages taken over multiple days. The following parameters shall be reported quarterly:
Average Daily Flow (mgd)
Maximum Daily Flow (mgd)
Minimum Daily Flow (mgd)
- (2) The sodium metabisulfite pumps and tanks shall be inspected daily for proper operation. The Discharger shall notify the Regional Water Board within 24 hours via telephone if the pumps and tanks are not operating as intended while discharging.

IV. EFFLUENT MONITORING REQUIREMENTS

A. Monitoring Location – E-001

The Discharger shall monitor treated effluent from the facility at E-001 as follows:

Table E-3. Effluent Monitoring – E-001

Parameter	Units	Sample Type	Minimum Sampling Frequency
Flow Rate ⁽¹⁾	mgd	Continuous	Cont/D
Chlorine Residual ⁽²⁾	mg/L	Grab	M
Total Dissolved Solids	mg/L	Grab	M
Acute Toxicity ⁽³⁾	% Survival	Grab	A
Priority Pollutants ⁽⁴⁾	µg/L	C-24	1/5Y
pH	Standard Units	Grab	W
Temperature	°C	Grab	W
Standard Observations	N.A.	Observations	W

Footnotes for Table E-3:

- (1) For effluent flows, flow monitoring shall be measured continuously and recorded daily, except on weekends and holidays, when the Discharger’s facility has limited staff to take measurements. During these periods, the average daily flow volume may be calculated by dividing the total flow volume for the period by the number of days of the period. The Discharger shall note when reporting these values that they are averages taken over multiple days. The following parameters shall be reported quarterly:
 - Average Daily Flow (mgd)
 - Maximum Daily Flow (mgd)
 - Minimum Daily Flow (mgd)
- (2) Analysis of chlorine residual shall use a method with a detection limit no greater than 0.05 mg/L. The residual chlorine level is considered in violation if it is at or above 0.05 mg/L. If residual chlorine measurements at E-001 are found to be above the effluent limitation, an alternative sample may be immediately collected at E-001a and measured to account for possible attenuation of residual chlorine in the storm drain system. The measurement at E-001a may be reported for compliance purposes if the Regional Water Board is notified within 24 hours and the event and E-001 measurement are described in the transmittal letter of the self-monitoring report. The Discharger may elect to use a continuous on-line monitoring system(s) for measuring flows, sodium hypochlorite and sodium metabisulfite dosage and concentration.
- (3) Acute bioassay tests shall be performed in accordance with Section V.A of this MRP. The following parameters shall be monitored on the sample stream used for the acute toxicity bioassays, at the start of the test and daily for the duration of the bioassay test, and the results reported:
 - Water Hardness (determined using the latest version of USEPA Method 130.2.)
 - Alkalinity
 - pH
 - Temperature
 - Dissolved Oxygen
 - Ammonia Nitrogen
- (4) Sampling for all priority pollutants in the SIP is addressed in the August 6, 2001 Letter: “*Requirements for Monitoring of Pollutants in Effluent and Receiving Water to Implement New Statewide Regulations and Policy*” (not attached but available for review or download on the Regional Water Board’s website at <http://www.waterboards.ca.gov/sanfranciscobay/>).

B. Monitoring Location – E-001a

The Discharger shall monitor treated effluent from the facility at E-001a as follows:

Table E-4. Effluent Monitoring – E-001a

Parameter	Units	Sample Type	Minimum Sampling Frequency
Chlorine Residual ⁽¹⁾	mg/L	Grab	---

Footnotes for Table E-4:

(1) If residual chlorine measurements at E-001 are found to be above the effluent limitation, an alternative sample may be immediately collected at E-001a and measured to account for possible attenuation of residual chlorine in the storm drain system. The measurement at E-001a may be reported for compliance purposes if the Regional Water Board is notified within 24 hours and the event and E-001 measurement are described in the transmittal letter of the self-monitoring report. Analysis of chlorine residual shall use a method with a detection limit no greater than 0.05 mg/L. The residual chlorine level is considered in violation if it is at or above 0.05 mg/L.

V. WHOLE EFFLUENT TOXICITY TESTING REQUIREMENTS

The Discharger shall monitor acute toxicity at E-001 as follows:

1. Compliance with the acute toxicity effluent limitations of this Order shall be evaluated by measuring survival of test organisms exposed to 96-hour static-renewal bioassays using grab samples representative of the discharged effluent.
2. Test organisms shall be fathead minnow or rainbow trout unless specified otherwise in writing by the Executive Officer.
3. All bioassays shall be performed according to the most up-to-date protocols in 40 CFR Part 136, currently in *Methods for Measuring the Acute Toxicity of Effluents and Receiving Water to Freshwater and Marine Organisms*, 5th Edition.
4. If specific identifiable substances in the discharge can be demonstrated by the Discharger as being rapidly rendered harmless upon discharge to the receiving water, compliance with the acute toxicity limit may be determined after the test samples are adjusted to remove the influence of those substances. Written approval from the Executive Officer must be obtained to authorize such an adjustment.
5. Effluent used for fish bioassays must be undiluted and dechlorinated prior to testing. Monitoring of the bioassay water shall include, on a daily basis, the following parameters: pH, dissolved oxygen, ammonia, temperature, hardness, and alkalinity. These results shall be reported. If a violation of acute toxicity requirements occurs or if the control fish survival rate is less than 90 percent, the bioassay test shall be restarted with new batches of fish and shall continue back to back until compliance is demonstrated.

VI. LAND DISCHARGE MONITORING REQUIREMENTS

Not Applicable

VII. RECLAMATION MONITORING REQUIREMENTS

Not Applicable

VIII. RECEIVING WATER MONITORING REQUIREMENTS – SURFACE WATER AND GROUNDWATER

A. Monitoring Locations – R-001, R-002

The Discharger shall continue to collect or participate in collecting background ambient receiving water monitoring as follows:

Table E-5. Receiving Water Monitoring – R-001

Parameter	Units	Sample Type	Minimum Sampling Frequency
Priority Pollutants ⁽¹⁾	µg/L	C-24	1/5Y
Dissolved Oxygen ⁽²⁾	mg/L	Grab	Q
Sulfide ⁽²⁾	mg/L	Grab	---
Hardness	mg/L CaCO ₃	Grab	Q
Salinity ⁽³⁾	Parts per thousand	Grab	Q
pH	Standard Units	Grab	Q
Temperature	°C	Grab	Q

Footnotes for Table E-5:

- (1) Sampling for all priority pollutants in the SIP is addressed in the August 6, 2001 Letter: “Requirements for Monitoring of Pollutants in Effluent and Receiving Water to Implement New Statewide Regulations and Policy” (not attached but available for review or download on the Regional Water Board’s website at <http://www.waterboards.ca.gov/sanfranciscobay/>).
- (2) Receiving water analysis for sulfides shall be run when dissolved oxygen is less than 2.0 mg/L.
- (3) Salinity can be analyzed through laboratory analysis or through extrapolation using a conductivity probe if the probe is calibrated and the calibration charts are submitted to Regional Water Board staff for approval.

Table E-6. Receiving Water Monitoring – R-002

Parameter	Units	Sample Type	Minimum Sampling Frequency
Dissolved Oxygen ⁽¹⁾	mg/L	Grab	Q
Sulfide ⁽¹⁾	mg/L	Grab	Q
Hardness	mg/L CaCO ₃	Grab	Q
Salinity ⁽²⁾	Parts per thousand	Grab	Q
pH	Standard Units	Grab	Q
Temperature	°C	Grab	Q

Footnotes for Table E-5:

- (1) Receiving water analysis for sulfides shall be run when dissolved oxygen is less than 2.0 mg/L.
- (2) Salinity can be analyzed through laboratory analysis or through extrapolation using a conductivity probe if the probe is calibrated and the calibration charts are submitted to Regional Water Board staff for approval.

IX. LEGEND FOR MRP TABLES

Types of Samples

- C-24 = composite sample, 24 hours
(includes continuous sampling, such as for flows)
C-X = composite sample, X hours
G = grab sample

Frequency of Sampling

- Cont. = Continuous
Cont/D = Continuous monitoring & daily reporting
H = once each hour (at about hourly intervals)
W = once each week
2/W = Twice each week
4/W = four times each week
M = once each month
Q = once each calendar quarter (at about three month intervals)
1/2h = once every 2 hours
1/Y = once each calendar year
2/Y = twice each calendar year (at about 6 months intervals, once during dry season, once during wet season)

Parameter and Unit Abbreviations

- CBOD = Carbonaceous Biochemical Oxygen Demand
D.O. = Dissolved Oxygen
Est V = Estimated Volume (gallons)
Metals = multiple metals; See SMP Section VI.G.
PAHs = Polycyclic Aromatic Hydrocarbons; See SMP Section VI.H.
TSS = Total Suspended Solids
mgd = million gallons per day
mg/L = milligrams per liter
ml/L-hr = milliliters per liter, per hour
µg/L = micrograms per liter
kg/d = kilograms per day
kg/mo = kilograms per month
MPN/100 ml = Most Probable Number per 100 milliliters

X. MODIFICATIONS TO PART A OF SELF-MONITORING PROGRAM (ATTACHMENT G)

Self-Monitoring Program Part A is hereby modified as follows:

1. Exemptions from Self-Monitoring Report Part A:

This monitoring program does not include the following sections of Part A: C.2.f, C.4, C.5, D.4, and E.3.

2. Modify section F.1 as follows:

- a. The second sentence of section F.1 shall be modified as follows: “Spills shall be reported immediately after the occurrence to the Regional Water Board at 510-622-2300 on weekdays during the hours of 8 a.m. to 5 p.m., and to the Office of Emergency Services at 1-800-852-7550 on weekends or when the spill occurred outside these hours.”
 - b. Section F.1.b is revised to read: “Best estimate of volume involved,”
 - c. Section F.1.d is revised to read: “Cause of spill or overflow,”
 - d. Section F.1.i is revised to read: “Agencies or persons notified,”
3. Replace section F.4 as follows:

Quarterly self-monitoring report: The purpose of this report is to document treatment performance, effluent quality, and compliance with waste discharge requirements prescribed by this Order, as demonstrated by the monitoring program data and the Discharger’s operation practices. The self-monitoring report (SMR) shall be submitted in accordance with the following:

- a. The report shall be submitted to the Regional Water Board on a quarterly basis, by the 30th day following the end of each quarter, on January 30, April 30, July 30, and October 30.
- b. *Letter of Transmittal:* Each report shall be submitted with a letter of transmittal. This letter shall include the following:
 - (1) Identification of all violations of effluent limits or other discharge requirements found during the monitoring period;
 - (2) Details of violations: parameters, magnitude, test results, frequency, and dates;
 - (3) Cause of violations;
 - (4) Discussion of corrective actions taken or planned to resolve violations and prevent recurrence, and dates or time schedule of action implementation. If previous reports have been submitted that address corrective actions, reference to such reports is satisfactory;
 - (5) *Signature:* The letter of transmittal shall be signed by the Discharger’s principal executive officer or ranking elected official, or duly authorized representative, and shall include the following certification statement:

“I certify under penalty of law that this document and all attachments have been prepared under my direction or supervision in accordance with a system designed to assure that qualified personnel properly gathered and evaluated the information submitted. The information submitted is, to the best of my knowledge and belief, true, accurate and complete. I am aware that there are significant penalties for submitting false information, including the possibility of fine and imprisonment.”

- c. *Compliance Evaluation Summary*: Each report shall include a compliance evaluation summary. This summary shall include, for each parameter for which effluent limits are specified in the Order, the number of samples taken during the monitoring period, and the number of samples in violation of applicable effluent limits.
- d. *Results of Analysis and Observations*:
 - (1) Tabulations of all required analyses and observations, including parameter, sample date and time, sample station, and test result;
 - (2) If any parameter specified in Table 1 of Part B is monitored more frequently than required by this Permit and SMP, the results of this additional monitoring shall be included in the monitoring report, and the data shall be included in data calculations and compliance evaluations for the monitoring period;
 - (3) Calculations for all effluent limits that require averaging of measurements shall utilize an arithmetic mean, unless specified otherwise in the Order or SMP.
- e. *Effluent Data Summary – USEPA NPDES Discharge Monitoring Reports*: Summary tabulations of monitoring data including maximum, minimum, and average values for subject monitoring period shall be reported in accordance with the format given by the USEPA NPDES Discharge Monitoring Report(s) (DMRs; USEPA Form 3320-1 or successor). Copies of these DMRs shall be provided to USEPA as required by USEPA.
- f. *Data Reporting for Results Not Yet Available*: The Discharger shall make all reasonable efforts to obtain analytical data for required parameter sampling in a timely manner. The Regional Water Board recognizes that certain analyses require additional time in order to complete analytical processes and result reporting. For cases where required monitoring parameters require additional time to complete analytical processes and reporting, and results are not available in time to be included in the SMR for the subject monitoring period, such cases shall be described in the SMR. Data for these parameters shall be included in the next following SMR after the data becomes available.
- g. *Report Submittal*: The Discharger shall submit SMRs to:

Executive Officer
Attn: NPDES Wastewater Division
California Regional Water Quality Control Board
San Francisco Bay Region
1515 Clay Street, Suite 1400
Oakland, CA 94612

- 4. Modify end of section F.4 as follows:
 - g. If the Discharger wishes to invalidate any measurement, the letter of transmittal shall include identification of the measurement suspected to be invalid and notification of intent to submit, within 60 days, a formal request to invalidate the measurement. This request must include the original measurement in question, the reason for invalidating the measurement, all relevant documentation that supports the invalidation (e.g., laboratory

sheet, log entry, test results, etc.), and discussion of the corrective actions taken or planned (with a time schedule for completion), to prevent the recurrence of the sampling or measurement problem.

- h. *Reporting Data in Electronic Format:* Discharger has the option to submit all monitoring results in an electronic reporting format approved by the Executive Officer. If the Discharger chooses to submit SMRs electronically, the following shall apply:
- (1) *Reporting Method:* The Discharger shall submit SMRs electronically via the process approved by the Executive Officer in a letter dated December 17, 1999, Official Implementation of Electronic Reporting System (ERS) and in the Progress Report letter dated December 17, 2000, or in a subsequently approved format that the Permit has been modified to include.
 - (2) *Monthly or Quarterly Reporting Requirements:* For each reporting period (monthly or quarterly as specified in SMP Part B), an electronic SMR shall be submitted to the Regional Water Board in accordance with section F.3.a.-g. above. However, until USEPA approves the electronic signature or other signature technologies, Dischargers that are using the ERS must submit a hard copy of the original transmittal letter, an ERS printout of the data sheet, a violation report, and a receipt of the electronic submittal.
 - (3) *Annual Reporting Requirements:* Dischargers who have submitted data using the ERS for at least one calendar year are exempt from submitting an annual report electronically, but a hard copy of the annual report shall be submitted according to Section F.5 below.

5. Modify section F.5 as follows:

An Annual Report shall be submitted for each calendar year. The report shall be submitted to the Regional Water Board by February 1 of the following year. This report shall include the following:

- a. Both tabular and graphical summaries of monitoring data collected during the calendar year that characterize treatment plant performance and compliance with waste discharge requirements.
- b. A comprehensive discussion of treatment plant performance and compliance with waste discharge requirements. This discussion should include any corrective actions taken or planned, such as changes to facility equipment or operation practices that may be needed to achieve compliance, and any other actions taken or planned that are intended to improve performance and reliability of the Discharger's wastewater collection, treatment or disposal practices.

XI. REPORTING REQUIREMENTS

A. General Monitoring and Reporting Requirements

The Discharger shall comply with all Standard Provisions (Attachment D) related to monitoring, reporting, and recordkeeping.

B. Self Monitoring Reports (SMRs)

1. At any time during the term of this Order, the State or Regional Water Board may notify the Discharger to electronically submit Self-Monitoring Reports (SMRs). Until such notification is given, the Discharger shall submit hard copy SMRs, except as described in Section X.
2. The Discharger shall report in the SMR the results for all monitoring specified in this MRP under sections III through XI. The Discharger shall submit quarterly and annual SMRs including the results of all required monitoring using USEPA-approved test methods or other test methods specified in this Order. If the Discharger monitors any pollutant more frequently than required by this Order, the results of this monitoring shall be included in the calculations and reporting of the data submitted in the SMR. Annual SMRs are due February 1, covering information from the previous calendar year.
3. Monitoring periods and reporting for all required monitoring shall be completed according to the following schedule:

Table E-7. Monitoring Periods and Reporting Schedule

Sampling Frequency	Monitoring Period Begins On...	Monitoring Period
Continuous	Day after permit effective date	All
Hourly	Day after permit effective date	Hourly
Daily	Day after permit effective date	Midnight through 11:59 PM or any 24-hour period that reasonably represents a calendar day for purposes of sampling.
Weekly	Sunday following permit effective date or on permit effective date if on a Sunday	Sunday through Saturday
Monthly	First day of calendar month following permit effective date or on permit effective date if that date is first day of the month	1 st day of calendar month through last day of calendar month
Quarterly	Closest of January 1, April 1, July 1, or October 1 following (or on) permit effective date	January 1 through March 31 April 1 through June 30 July 1 through September 30 October 1 through December 31
Semiannually	Closest of January 1 or July 1 following (or on) permit effective date	January 1 through June 30 July 1 through December 31
Annually	January 1 following (or on) permit effective date	January 1 through December 31
Per Discharge Event	Anytime during the discharge event or as soon as possible after aware of the event	At a time when sampling can characterize the discharge event

4. The Discharger shall report with each sample result the applicable Reporting Level (RL) and the current Method Detection Limit (MDL), as determined by the procedure in 40 CFR §136.

The Discharger shall report the results of analytical determinations for the presence of chemical constituents in a sample using the following reporting protocols:

- a. Sample results greater than or equal to the RL shall be reported as measured by the laboratory (i.e., the measured chemical concentration in the sample).
- b. Sample results less than the RL, but greater than or equal to the laboratory's MDL, shall be reported as "Detected, but Not Quantified," or DNQ. The estimated chemical concentration of the sample shall also be reported.

For the purposes of data collection, the laboratory shall write the estimated chemical concentration next to DNQ as well as the words "Estimated Concentration" (may be shortened to "Est. Conc."). The laboratory may, if such information is available, include numerical estimates of the data quality for the reported result. Numerical estimates of data quality may be percent accuracy (\pm a percentage of the reported value), numerical ranges (low to high), or any other means considered appropriate by the laboratory.

- c. Sample results less than the laboratory's MDL shall be reported as "Not Detected," or ND.
 - d. Dischargers are to instruct laboratories to establish calibration standards so that the ML value (or its equivalent if there is differential treatment of samples relative to calibration standards) is the lowest calibration standard. At no time is the Discharger to use analytical data derived from *extrapolation* beyond the lowest point of the calibration curve.
5. The Discharger shall submit SMRs in accordance with the following requirements:
 - a. The Discharger shall arrange all reported data in a tabular format. The data shall be summarized to clearly illustrate whether the facility is operating in compliance with effluent limitations. The Discharger is not required to duplicate the submittal of data that is entered in a tabular format within CIWQS. When electronic submittal of data is required and CIWQS does not provide for entry into a tabular format within the system, the Discharger shall electronically submit the data in a tabular format as an attachment.
 - b. The Discharger shall attach a cover letter to the SMR. The information contained in the cover letter shall clearly identify violations of the WDRs, discuss corrective actions taken or planned, and provide the proposed time schedule for corrective actions. Identified violations must include a description of the requirement that was violated and a description of the violation.
 - c. SMRs must be submitted to the Regional Water Board, signed and certified as required by the Standard Provisions (Attachment D), to the address listed below:

Executive Officer
ATTN: NPDES Wastewater Division
California Regional Water Quality Control Board
San Francisco Bay Region
1515 Clay Street, Suite 1400
Oakland, CA 94612

C. Discharge Monitoring Reports (DMRs)

1. As described in Section XII.B.1 above, at any time during the term of this Order, the State or Regional Water Board may notify the Discharger to electronically submit SMRs that will satisfy federal requirements for submittal of Discharge Monitoring Reports (DMRs). Until such notification is given, the Discharger shall submit DMRs in accordance with the requirements described below.
2. DMRs must be signed and certified as required by the standard provisions (Attachment D). The Discharger shall submit the original DMR and one copy of the DMR to one of the addresses listed below:

Standard Mail	FedEx/UPS/Other Private Carriers
State Water Resources Control Board Division of Water Quality c/o DMR Processing Center PO Box 100 Sacramento, CA 95812-1000	State Water Resources Control Board Division of Water Quality c/o DMR Processing Center 1001 I Street, 15 th Floor Sacramento, CA 95814

3. All discharge monitoring results must be reported on the official USEPA pre-printed DMR forms (EPA Form 3320-1). Forms that are self-generated will not be accepted unless they follow the exact same format of EPA Form 3320-1.

D. Other Reports

Annually, with the first monthly SMR following the respective due dates, the Discharger shall report the results of any special studies, monitoring, and reporting required by section VI. C. 2 (Special Studies, Technical Reports, and Additional Monitoring Requirements) of this Order.

ATTACHMENT F – FACT SHEET

Table of Contents

I.	Permit Information.....	F-3
II.	Facility Description.....	F-4
	A. Description of Wastewater Treatment or Controls.....	F-4
	B. Discharge Points and Receiving Waters	F-5
	C. Summary of Existing Requirements and Self-Monitoring Report (SMR) Data	F-5
	D. Compliance Summary	F-5
	E. Planned Changes	F-7
III.	Applicable Plans, Policies, and Regulations.....	F-7
	A. Legal Authorities.....	F-7
	B. California Environmental Quality Act (CEQA).....	F-7
	C. State and Federal Regulations, Policies, and Plans	F-7
	D. Impaired Water Bodies on CWA 303(d) List	F-10
	E. Other Plans, Policies and Regulations.....	F-10
IV.	Rationale For Effluent Limitations and Discharge Specifications	F-11
	A. Discharge Prohibitions	F-11
	B. Technology-Based Effluent Limitations	F-11
	1. Scope and Authority	F-11
	2. Technology-Based Effluent Limitations	F-12
	C. Water Quality-Based Effluent Limitations (WQBELs).....	F-13
	1. Scope and Authority	F-13
	2. Applicable Beneficial Uses and Water Quality Criteria and Objectives.....	F-13
	3. Determining the Need for WQBELs	F-15
	4. WQBEL Calculations.....	F-21
	5. Whole Effluent Acute Toxicity	F-21
	D. Effluent Limitations	F-21
	E. Land Discharge Specifications.....	F-23
	F. Reclamation Specifications	F-23
V.	Rationale for Receiving Water Limitations.....	F-23
	A. Receiving Water Limitations V.A. (Surface Water Limitations).....	F-23
	B. Receiving Water Limitations V.B (Groundwater Limitations).....	F-23
VI.	Rationale for Monitoring and Reporting Requirements	F-23
	A. Influent Monitoring	F-24
	B. Effluent Monitoring.....	F-24
	C. Receiving Water Monitoring.....	F-24
	D. Other Monitoring Requirements	F-24
VII.	Rationale for Provisions.....	F-24
	A. Standard Provisions (Provision VI.A).....	F-24
	B. Monitoring and Reporting Requirements (Provision VI.B).....	F-25
	C. Special Provisions (Provision VI.C)	F-25
	1. Reopener Provisions.....	F-25
	2. Special Studies and Additional Monitoring Requirements	F-25
	3. Construction, Operation, and Maintenance Specifications	F-25
VIII.	Public Participation.....	F-26
	A. Notification of Interested Parties.....	F-26

B. Written Comments	F-26
C. Public Hearing	F-26
D. Waste Discharge Requirements Petitions.....	F-27
E. Information and Copying	F-27
F. Register of Interested Persons	F-27
G. Additional Information.....	F-27

List of Tables

Table F-1. Facility Information.....	F-3
Table F-2. Discharge Point	F-5
Table F-3. Previous Effluent Limitations (Order No. R2-2003-0051) and Monitoring Data.....	F-5
Table F-4. Numeric Effluent Limitation Compliance.....	F-6
Table F-5. Permit Provision Compliance.....	F-6
Table F-6. Factors Considered Pursuant to 40 CFR 125.3(d).....	F-12
Table F-7. Summary of Technology-Based Effluent Limitations	F-13
Table F-8. Basin Plan Beneficial Uses	F-13
Table F-9. Summary of RPA Results	F-18
Table F-10. Summary of Final Effluent Limitations	F-21

ATTACHMENT F – FACT SHEET

As described in Section II of this Order, this Fact Sheet includes the legal requirements and technical rationale that serve as the basis for the requirements of this Order.

This Order has been prepared under a standardized format to accommodate a broad range of discharge requirements for dischargers in California. Only those sections or subsections of this Order that are specifically identified as “not applicable” have been determined not to apply to this Discharger. Sections or subsections of this Order not specifically identified as “not applicable” fully apply to this Discharger.

I. PERMIT INFORMATION

The following table summarizes administrative information related to the facility.

Table F-1. Facility Information

WDID	2 011932001
Discharger	Bottling Group, LLC
Name of Facility	Bottling Group, Hayward Plant
Facility Address	29000 Hesperian Blvd.
	Hayward, CA 94545
	Alameda County
Facility Contact, Title, Phone	Pranav Desai (510) 781-3688
Authorized Person to Sign and Submit Reports	Wendy Smith, Plant Manager, (510) 781-3627
Mailing Address	Same as Facility Address
Billing Address	Same as Facility Address
Type of Facility	Bottled water and soft drink manufacturing, bottling, and distribution facility
Major or Minor Facility	Minor
Threat to Water Quality	2
Complexity	B
Pretreatment Program	No
Reclamation Requirements	No
Facility Permitted Flow	143,000 gallons per day (mgd) (projected average monthly discharge rate)
Facility Design Flow	900,000 gallons per day (current maximum design treatment capacity)
Watershed	Alameda Creek
Receiving Water	Alameda County Flood Control and Water Conservation District Zone 3 Line A Flood Channel
Receiving Water Type	Freshwater

- A. The Bottling Group, LLC (hereinafter the Discharger) owns and operates the Hayward Plant, which discharges to the Alameda County Flood Control and Water Conservation District Flood Channel (Flood Channel).

For the purposes of this Order, references to the “discharger” or “permittee” in applicable federal and state laws, regulations, plans, or policy are held to be equivalent to references to the Discharger herein.

- B. The facility discharges reverse osmosis concentrate into the Flood Channel, a water of the United States, and is currently regulated by NPDES Permit No. CA0030058 (Order No. R2-2003-0051), which was adopted on May 18, 2003 and expires on July 31, 2008.
- C. The Discharger filed a Report of Waste Discharge and submitted an application for renewal of its Waste Discharge Requirements (WDRs) and NPDES permit on November 30, 2007.

II. FACILITY DESCRIPTION

A. Description of Wastewater Treatment or Controls

The Discharger owns and operates the Hayward Plant, which is a bottled water and soft drink manufacturing, bottling and distribution facility. The Hayward Plant uses potable water supplied by the City of Hayward. The water must be purified at the facility to remove minerals, metals, and residual chlorine prior to the manufacture of soft drinks and bottled water. The concentration of residual chlorine in the city potable water varies.

The Discharger's treatment system includes particulate filtration, reverse osmosis (RO), and chemical addition. Filtration through three greensand filters, which are composed of anthracite and manganese greensand, removes solids, soluble iron, and manganese. The filtrate is then treated with an anti-scalent and sodium metabisulfite prior to RO treatment to prevent membrane fouling and remove chlorine. Pre-filtration through three 304-grade stainless steel cartridge filters fitted with twelve 5 µm filters removes suspended solids. RO removes 99% of dissolved minerals and is followed by granular activated carbon treatment to remove trihalomethanes and other taste, color, and odor producing organics. A final polishing filtration of the RO filtrate removes granular activated carbon fines, and ultraviolet sterilization of the RO permeate disinfects the final product water.

The RO treatment step removes dissolved minerals by forcing the influent stream with pressure through a sheet of semi-permeable membranes against osmotic pressure. The stream that contains the dissolved minerals is the RO reject or concentrate. The Discharger's RO system is rated to process a maximum influent stream of 900,000 gallons per day. Approximately 20 percent of the influent is discharged as RO concentrate.

The RO concentrate stream is discharged from Discharge Point 001 to an onsite storm drain that connects with an offsite storm sewer, which drains to the wet well of the Alameda County Besco Pump Station. The pump station lifts the effluent and discharges to the Flood Channel, which drains to Old Alameda Creek. Old Alameda Creek is the downstream section of Alameda Creek and is tributary to San Francisco Bay. The Discharger discharges an average monthly flow of 110,000 gallons per day, and a maximum daily flow of 180,000 gallons per day of the RO concentrate.

In its Report of Waste Discharge, dated November 30, 2007, the Discharger states that it anticipates a 30 percent increase in production at its Hayward Plant. This would increase the effluent volume discharged to the Flood Channel. Order No. R2-2003-0051 limited the average monthly discharge to 110,000 gallons per day. The Discharger thus requested an increase in the permitted average monthly discharge to 143,000 gallons per day, which this Order provides.

B. Discharge Points and Receiving Waters

The discharge point for this Discharger is shown in Table F-2 below.

Table F-2. Discharge Point

Discharge Point	Effluent Description	Discharge Point Latitude	Discharge Point Longitude	Receiving Water
001	RO concentrate	37° 36' 54" N	122° 5' 4" W	Alameda County Flood Control and Water Conservation District Flood Channel

C. Summary of Existing Requirements and Self-Monitoring Report (SMR) Data

Effluent limitations contained in the previous Order (Order No. R2-2003-0051) for discharges to the Flood Channel and representative monitoring data from the term of the previous Order are as follows:

Table F-3. Previous Effluent Limitations (Order No. R2-2003-0051) and Monitoring Data

Parameter	Units	Effluent Limitations			Monitoring Data (November 2004 To October 2007)
		Monthly Average	Daily Maximum	Instantaneous Maximum	Highest Discharge
Flow	gallons/day	110,000	---	---	---
Total Chlorine Residual ⁽¹⁾	mg/L	---	---	0.0	0.05
pH	standard units	---	---	6.5 – 8.5	8.7
Acute Toxicity ⁽²⁾⁽³⁾	% survival	---	---	---	---
Copper	mg/L	2.4	4.8	---	7.1
Lead	mg/L	0.45	0.9	---	0.3 ⁽⁴⁾

Footnotes for Table E-3:

- (1) Defined as below the limit of detection of standard test methods (0.05 mg/L), as described in the latest edition of *Standard Methods for the Examination of Water and Wastewater*.
- (2) Acute Toxicity Effluent Limits:
The survival of bioassay test organisms in 96-hour bioassays of undiluted effluent shall be:
 - (i) A 3-sample median value of not less than 90 percent survival; and
 - (ii) A 1-sample 90th value of not less than 70 percent survival.
- (3) No exceedances of the acute toxicity limit were observed during the term of the previous permit.
- (4) Estimated value.

D. Compliance Summary

1. Compliance with Numeric Effluent Limits.

There were three exceedances of effluent limitations during the term of Order No. R2-2003-0051, which are summarized in Table F-4 below. Mandatory Minimum Penalty

Complaint No. R2-2002-0052 covered two residual chlorine violations that occurred between January 1, 2000 and September 30, 2001.

Table F-4. Numeric Effluent Limitation Compliance

Parameter	Units	Effluent Limitation	Reported Value	Violation
pH	standard units	6.5 – 8.5	6.29	Exceedance of lower limitation for pH on April 16, 2004
pH	standard units	6.5-8.5	8.7	Exceedance of upper limitation for pH on June 29, 2005
pH	standard units	6.5 – 8.5	8.7	Exceedance of upper limitation for pH on November 19, 2007

2. Compliance with Permit Provisions.

A list of special activities required by the provisions of Order No. R2-2003-0051 and the status of completion are shown in Table F-5 below.

Table F-5. Permit Provision Compliance.

Provision Number	Requirement	Status of Completion
D.1	Permit Compliance and Rescission of Previous Waste Discharge Requirements	Ongoing
D.2	Receiving Water Monitoring: Participate in collecting background ambient receiving water monitoring for priority pollutants. The Discharger shall submit a final report that presents all data to the Board 180 days prior to permit expiration.	Receiving water priority pollutant data submitted 11/28/07
D.3	Whole Effluent Acute Toxicity: 96 hour flow through or static renewal bioassays using rainbow trout or fathead minnow	Ongoing
D.4	Copper Compliance Schedule: 1. Submit a report that identifies source of copper and that proposes a work plan. 2. Submit an annual report describing status of the work accomplished towards compliance with the WQBELs for copper. 3. Full compliance with final WQBELs for copper.	1. Source report and work plan submitted 2. Annual status reports were submitted 3. Ongoing
D.5	Lead Compliance Schedule: 1. Submit a report that identifies sources of lead and that proposes a work plan. 2. Submit an annual report describing status of the work accomplished towards compliance with the WQBELs for lead. 3. Full compliance with final WQBELs for lead.	1. Source report and work plan submitted 2. Annual status reports submitted 3. Ongoing
D.6	Operation and Maintenance Manual	Letter describing annual review of the Operation and Maintenance manual submitted in 2004 and 2007
D.7	Self Monitoring Program: Comply with the Self-Monitoring Program (SMP) for this Order.	Annuals SMRs were submitted
D.8	Standard Provisions and Reporting Requirements	Ongoing
D.9	Change in Control or Ownership	Notification of the Regional Water Board and request to

		transfer the Order was submitted
D.10	Permit Reopener	Ongoing
D.11	NPDES Permit	Ongoing
D.12	Order Expiration and Reapplication	Ongoing

E. Planned Changes

In its Report of Waste Discharge, dated November 30, 2007, the Discharger states that it anticipates a 30 percent increase in production at its Hayward Plant. This would increase the effluent volume discharged. Order No. R2-2003-0051 limited the average monthly discharge to 110,000 gallons per day. The Discharger thus requested an increase in the permitted average monthly discharge to 143,000 gallons per day, which this Order provides.

III. APPLICABLE PLANS, POLICIES, AND REGULATIONS

The requirements contained in the proposed Order are based on the requirements and authorities described in this section.

A. Legal Authorities

This Order is issued pursuant to section 402 of the federal Clean Water Act (CWA) and implementing regulations adopted by the USEPA and Chapter 5.5, Division 7 of the California Water Code (CWC) (commencing with section 13370). It shall serve as an NPDES permit for point source discharges from this facility to surface waters. This Order also serves as WDRs pursuant to CWC Article 4, Chapter 4, Division 7 (commencing with section 13260).

B. California Environmental Quality Act (CEQA)

Under CWC section 13389, this action to adopt an NPDES permit is exempt from the provisions of CEQA.

C. State and Federal Regulations, Policies, and Plans

1. Water Quality Control Plans. *The Water Quality Control Plan for the San Francisco Bay Basin* (the Basin Plan) is the Regional Water Board’s master water quality control planning document. It designates beneficial uses and water quality objectives for waters of the State, including surface waters and groundwater. It also includes programs of implementation to achieve water quality objectives. The Basin Plan was adopted by the Regional Water Board and approved by the State Water Resources Control Board, USEPA, and the Office of Administrative Law, as required. The latest version of the Basin Plan became effective on December 22, 2006.

The Basin Plan implements State Water Resources Control Board (State Water Board) Resolution No. 88-63, which establishes state policy that all waters, with certain exceptions, should be considered suitable or potentially suitable for municipal or domestic supply (MUN). As described in Finding H. of the Order, the receiving water for this Discharger meets an exception to Resolution No. 88-63 and therefore is not designated as a municipal or domestic supply.

Table 4-1 of the Basin Plan contains a prohibition against the discharge of any wastewater “which has particular characteristics of concern to beneficial uses at any point at which the wastewater does not receive a minimal initial dilution of at least 10:1.” By Order No. 97-007, the Regional Water Board established an exception to this prohibition based on determination that the discharge did not contain pollutants of concern to beneficial uses, provided that discharge limitations contained in the Order were met. The exception was continued in Order No. R2-2003-0051 and is continued by this Order. For this current Order, the Regional Water Board has determined through reasonable potential analysis (Fact Sheet IV.C.3.) that priority pollutants will not be present in the discharge at levels of concern to beneficial uses.

Requirements of this Order implement the Basin Plan.

- 2. National Toxics Rule (NTR) and California Toxics Rule (CTR).** USEPA adopted the NTR on December 22, 1992, and amended it on May 4, 1995, and November 9, 1999. About forty criteria in the NTR applied in California. On May 18, 2000, USEPA adopted the CTR. The CTR promulgated new toxics criteria for California and, in addition, incorporated the previously adopted NTR criteria that were applicable in the state. The CTR was amended on February 13, 2001. These rules contain water quality criteria for priority toxic pollutants, which are applicable to the receiving water for this Discharger.
- 3. State Implementation Policy.** On March 2, 2000, the State Water Board adopted the *Policy for Implementation of Toxics Standards for Inland Surface Waters, Enclosed Bays, and Estuaries of California* (State Implementation Policy or SIP). The SIP became effective on April 28, 2000, with respect to the priority pollutant criteria promulgated for California by the USEPA through the NTR and to the priority pollutant objectives established by the Regional Water Board in the Basin Plan. The SIP became effective on May 18, 2000 with respect to the priority pollutant criteria promulgated by the USEPA through the CTR. The State Water Board adopted amendments to the SIP on February 24, 2005 that became effective on July 13, 2005. The SIP establishes implementation provisions for priority pollutant criteria and objectives and provisions for chronic toxicity control. Requirements of this Order implement the SIP.
- 4. Alaska Rule.** On March 30, 2000, USEPA revised its regulation that specifies when new and revised state and tribal water quality standards (WQS) become effective for CWA purposes [65 Fed. Reg. 24641 (April 27, 2000)(codified at 40 CFR §131.21)]. Under the revised regulation (also known as the Alaska Rule), new and revised standards submitted to USEPA after May 30, 2000, must be approved by USEPA before being used for CWA purposes. The final rule also provides that standards already in effect and submitted to USEPA by May 30, 2000, may be used for CWA purposes, whether or not approved by USEPA.
- 5. Stringency of Requirements for Individual Pollutants.** This Order contains restrictions on individual pollutants that are no more stringent than required by the federal CWA. Individual pollutant restrictions consist of technology-based restrictions and water quality-based effluent limitations. The technology-based effluent limitations consist of restriction on BOD₅, TSS, oil and grease, pH and chlorine residual. Restrictions on these pollutants are specified in federal regulations and in the Basin Plan. The permit’s technology-based pollutant restrictions are no more stringent than required by the CWA.

WQBELs have been derived to implement water quality objectives that protect beneficial uses. Both the beneficial uses and the water quality objectives have been approved pursuant to federal law and are the applicable federal water quality standards. To the extent that WQBELs for toxic pollutants were derived from the CTR, the CTR is the applicable standard pursuant to 40 CFR §131.38. The procedures for calculating the individual WQBELs are based on the SIP, which was approved by USEPA on May 18, 2000. Most beneficial uses and water quality objectives contained in the Basin Plan were approved under State law and submitted to and approved by USEPA prior to May 30, 2000. Any water quality objectives and beneficial uses submitted to USEPA prior to May 30, 2000, but not approved by USEPA before that date are, nonetheless, “applicable water quality standards for purposes of the CWA” pursuant to 40 CFR §131.21(c)(1). The remaining water quality objectives and beneficial uses implemented by this Order were approved by USEPA on January 5, 2005, and are applicable water quality standards pursuant to 40 CFR §131.21(c)(2). Collectively, this Order’s restrictions on individual pollutants are no more stringent than required to implement the technology-based requirements of the CWA and are the applicable water quality standards for purposes of the CWA.

- 6. Antidegradation Policy.** NPDES regulations at 40 CFR §131.12 require that State water quality standards include an antidegradation policy consistent with the federal policy. The State Water Board established California’s antidegradation policy in State Board Resolution No. 68-16, which incorporates the requirements of the federal antidegradation policy. Resolution No. 68-16 requires:

Whenever the existing quality of water is better than the quality established in policies as of the date on which such policies become effective, such existing high quality will be maintained until it has been demonstrated to the State that any change will be consistent with the maximum benefit to the people of the State, will not unreasonably affect present and anticipated beneficial use of such water and will not result in water quality less than that prescribed in the policies; and

Any activity which produces or may produce a waste or increased volume or concentration of waste and which discharges or proposes to discharge to existing high quality waters will be required to meet waste discharge requirements which will result in the best practicable treatment or control of the discharge necessary to assure that (a) pollution or a nuisance will not occur and (b) the highest water quality consistent with the maximum benefit to the people of the State will be maintained.

The Tentative Order authorizes an increased rate of discharge from the Bottling Group Hayward Plant. The Regional Water Board has determined that the Order is consistent with applicable State and federal antidegradation policy. Compliance with antidegradation policies is discussed in Section IV.D.2. below.

- 7. Anti-Backsliding Requirements.** CWA Sections 402(o)(2) and 303(d)(4) and NPDES regulations at 40 CFR §122.44(l) prohibit backsliding in NPDES permits. These anti-backsliding provisions require that effluent limitations in a reissued permit must be as stringent as those in the previous permit, with some exceptions in which limitations may be relaxed.

Except for limitations for copper and lead, all limitations established by the Tentative Order are at least as stringent as limitations established by Order No. R2-2003-0051.

Effluent limitations for copper and lead are not retained by this Order. Elimination of WQBELs for these pollutants is consistent with State Water Resources Control Board Order WQ 2001-16.

- 8. Monitoring and Reporting Requirements.** 40 CFR §122.48 requires that all NPDES permits specify requirements for recording and reporting monitoring results. CWC Sections §13267 and §13383 authorize the Regional Water Boards to require technical and monitoring reports. The MRP may be amended by the Executive Officer pursuant to USEPA regulations at 40 CFR §122.62, §122.63, and §124.5.

D. Impaired Water Bodies on CWA 303(d) List

In November 2006, the USEPA approved a revised list of impaired water bodies prepared by the State (hereinafter referred to as the 303(d) list), prepared pursuant to provisions of CWA section 303(d), which requires identification of specific water bodies where it is expected that water quality standards will not be met after implementation of technology-based effluent limitations on point sources. The Flood Channel is not 303(d) listed as an impaired waterbody.

E. Other Plans, Policies and Regulations

This Order is also based on the following plans, policies, and regulations:

1. The Federal *Water Pollution Control Act*, CWA Sections 301 through 305, and 307, and amendments thereto, as applicable;
2. The State Water Board's March 2, 2000 *Policy for Implementation of Toxics Standards for Inland Surface Water Enclosed Bays, and Estuaries of California*; the USEPA's May 18, 2000 *Water Quality Standards; Establishment of Numeric Criteria for Priority Toxic Pollutants for the State of California* or CTR, 40 CFR §131.38(b) and amendments;
3. The USEPA's *Quality Criteria for Water* [EPA 440/5-86-001, 1986] and subsequent amendments (the USEPA Gold Book);
4. Applicable Federal Regulations [40 CFR §122 and §131];
5. 40 CFR §131.36(b) and amendments [Federal Register Volume 60, Number 86, 4 May 1995, pages 22229-22237];
6. USEPA's December 10, 1998 National Recommended Water Quality Criteria compilation [Federal Register Vol. 63, No. 237, pp. 68354-68364];
7. USEPA's December 27, 2002 Revision of National Recommended Water Quality Criteria compilation [Federal Register Vol. 67, No. 249, pp. 79091-79095]; and
8. Guidance provided with State Water Board Orders remanding permits to the Regional Water Board for further consideration.

IV. RATIONALE FOR EFFLUENT LIMITATIONS AND DISCHARGE SPECIFICATIONS

The CWA requires point source dischargers to control the amount of conventional, non-conventional, and toxic pollutants that are discharged into the waters of the United States. The control of pollutants discharged is established through effluent limitations and other requirements in NPDES permits. There are two principal bases for effluent limitations in the NPDES regulations: 40 CFR §122.44(a) requires that permits include applicable technology-based limitations and standards; and 40 CFR §122.44(d) requires that permits include water quality-based effluent limitations (WQBELs) to attain and maintain applicable numeric and narrative water quality criteria to protect the beneficial uses of the receiving water. Where reasonable potential has been established for a pollutant, but there is no numeric criterion or objective for the pollutant, WQBELs may be established: (1) using USEPA criteria guidance under CWA section 304(a), supplemented where necessary by other relevant information; (2) on an indicator parameter for the pollutant of concern; or (3) using a calculated numeric water quality criterion, such as a proposed state criterion or policy interpreting the state's narrative criterion, supplemented with other relevant information, as provided in 40 CFR §122.44(d)(1)(vi).

Several specific factors affecting the development of limitations and requirements in this Order are discussed as follows.

A. Discharge Prohibitions

1. Discharge Prohibitions III.A (No discharge other than that described in this Order):

This prohibition is retained from the previous permit and is based on California Water Code section 13260, which requires filing a Report of Waste Discharge before discharges can occur. Discharges not described in the Report of Waste Discharge, and subsequently in the Order, are prohibited.

2. Discharge Prohibitions III.B (No discharge greater than a monthly average of 143,000 gallons per day):

This prohibition is based on the Discharger's Report of Waste Discharge in which the Discharger requested an increase in its permitted average monthly discharge to 143,000 gallons per day due to a 30 percent increase in the projected facility production rate. This increased flow is within the design treatment capacity of the RO system of 900,000 gallons per day. Therefore, it continues to reflect the reliable treatment capacity of the RO system. The requirements of this Order are based on this increased flow.

B. Technology-Based Effluent Limitations

1. Scope and Authority

The CWA requires technology-based effluent limitations to be established based on several levels of control:

- a. Best practical treatment control technology (BPT) represents the average of the best performance by plants within an industrial category or subcategory. BPT standards apply to toxic, conventional, and non-conventional pollutants.
- b. Best available technology economically achievable (BAT) represents the best existing performance of treatment technologies that are economically achievable within an

industrial point source category. BAT standards apply to toxic and non-conventional pollutants.

- c. Best conventional pollutant control technology (BCT) represents the control from existing industrial point source of conventional pollutants including BOD, TSS, total coliform, pH, and oil and grease. The BCT standard is established after considering the relationship between the cost of attaining a reduction in effluent discharge and the benefits that would result, and the cost effectiveness of additional industrial treatment beyond BPT.
- d. New source performance standards (NSPS) represent the best available demonstrated control technology standards. The intent of the NSPS guidelines is to set limitations that represent state-of-the-art treatment technology for new sources.

The CWA requires USEPA to develop effluent limitations, guidelines and standards (ELGs) representing application of BPT, BAT, BCT, and NSPS. Sections 402(a)(1) of the CWA and section 125.3 of the Code of Federal Regulations authorize the use of best professional judgment (BPJ) to derive technology-based effluent limitations on a case-by-case basis where ELGs are not available for certain industrial categories and/or pollutants of concern. USEPA has not issued ELGs for the discharge of reverse osmosis brine reject water.

2. Technology-Based Effluent Limitations

The technology-based effluent limitations for this permit are based on the Basin Plan and BPJ. In setting these limits, the factors specified in section 125.3(d), as shown in the table below were considered.

Table F-6. Factors Considered Pursuant to 40 CFR 125.3(d)

Factors	Considerations
Cost relative to benefits	The cost of imposing these limits is reasonable given that the Discharger can comply without modifying the existing process.
Comparison of cost and pollutant reductions from publicly owned treatment works to cost and pollutant reductions from reverse osmosis units	The wastewater is a byproduct of a treatment process to obtain high-quality water for the Discharger's commercial products. No additional wastewater treatment to remove pollutants occurs. Therefore, the cost is less than if it were treated at a publicly owned treatment works.
Age of equipment and facilities	The limits can be met with existing equipment and facilities.
Process employed	The limits can be met with the existing process.
Engineering aspects of various controls	The existing controls are practicable and capable of meeting the limits.
Process changes	No process changes are necessary to meet the limits.
Non-water quality environmental impacts	Because no process changes are necessary, no non-water quality impacts are foreseeable.

The Order retains the following technology based effluent limitations, applicable to Discharge Point 001, from the previous permit. The limitations for pH and total residual chlorine are based on Table 4-2 of the Basin Plan.

Table F-7. Summary of Technology-Based Effluent Limitations

Parameter	Units	Effluent Limitations		
		Average Monthly	Instantaneous Minimum	Instantaneous Maximum
pH	standard units	---	6.5	8.5
Total Residual Chlorine ⁽¹⁾	mg/L	---	---	0.0

Footnote for Table F-7:

(1) This requirement is defined as below the limit of detection of standard test methods (0.05 mg/L), as described in the latest edition of *Standard Methods for the Examination of Water and Wastewater*.

C. Water Quality-Based Effluent Limitations (WQBELs)

1. Scope and Authority

NPDES regulations at 40 CFR §122.44(d)(1)(i), require permits to include WQBELs for pollutants (including toxicity) that are or may be discharged at levels that cause, have reasonable potential to cause, or contribute to an excursion above any state water quality standard (Reasonable Potential). The process for determining Reasonable Potential and, when necessary, calculating WQBELs is intended to (1) protect the designated beneficial uses of the receiving water specified in the Basin Plan, and (2) achieve applicable WQOs and WQC that are contained in the California Toxics Rule (CTR), National Toxics Rule (NTR), Basin Plan, and other State plans and policies.

2. Applicable Beneficial Uses and Water Quality Criteria and Objectives

The WQC and WQOs applicable to the receiving waters for this discharge are from the Basin Plan; the California Toxics Rule (CTR), established by USEPA at 40 CFR §131.38; and the National Toxics Rule (NTR), established by USEPA at 40 CFR §131.36. Some pollutants have WQC/WQOs established by more than one of these three sources.

a. Applicable Beneficial Uses. The Basin Plan does not designate beneficial uses specifically for the Flood Channel; therefore applicable beneficial uses for Alameda Creek and its tributaries (e.g., Flood Channel) are as follows:

Table F-8. Basin Plan Beneficial Uses

Discharge Point	Receiving Water Name	Beneficial Use(s)
001	Alameda Creek	Agricultural Supply (AGR) Groundwater Recharge (GWR) Cold Freshwater Habitat (COLD) Warm Freshwater Habitat (WARM) Water Contact Recreation (REC1) Non-Contact Water Recreation (REC2) Wildlife Habitat (WILD) Fish Migration (MIGR) Fish Spawning (SPWN)

The Basin Plan implements State Water Resources Control Board (State Water Board) Resolution No. 88-63, which establishes State policy that all waters, with certain exceptions, should be considered suitable or potentially suitable for municipal or domestic supply (MUN). The Flood Channel is a system designed to collect storm water run-off, monitored through the Alameda Countrywide Clean Water Program, and thereby meets an exception to State Water Board Resolution No. 88-63. Therefore, the MUN designation is not applicable to the Flood Channel.

- b. Basin Plan.** The Basin Plan specifies numeric WQOs for 10 priority toxic pollutants, as well as narrative WQOs for toxicity and bioaccumulation in order to protect beneficial uses. The pollutants for which the Basin Plan specifies numeric objectives are arsenic, cadmium, chromium (VI), copper in freshwater, lead, mercury, nickel, silver, zinc, and cyanide. The narrative toxicity objective states in part that “[a]ll waters shall be maintained free of toxic substances in concentrations that are lethal to or that produce other detrimental responses in aquatic organisms.” The bioaccumulation objective states in part that “[c]ontrollable water quality factors shall not cause a detrimental increase in concentrations of toxic substances found in bottom sediments or aquatic life. Effects on aquatic organisms, wildlife, and human health will be considered.” Effluent limitations and provisions contained in this Order are designed implement these objectives, based on available information.
- c. CTR.** The CTR specifies numeric aquatic life criteria for 23 priority toxic pollutants and numeric human health criteria for 57 priority toxic pollutants. These criteria apply to all inland surface waters and enclosed bays and estuaries of the San Francisco Bay Region, although Tables 3-3 and 3-4 of the Basin Plan include numeric objectives for certain of these priority toxic pollutants, which supersede criteria of the CTR (except in the South Bay south of the Dumbarton Bridge).
- d. NTR.** The NTR establishes numeric aquatic life criteria for selenium, numeric aquatic life and human health criteria for cyanide, and numeric human health criteria for 34 toxic organic pollutants for inland surface waters and waters of San Francisco Bay upstream to, and including Suisun Bay and the Delta. These criteria of the NTR are applicable to the ACFCWCD Flood Channel, the receiving water for this Discharger.
- e. Technical Support Document for Water Quality-Based Toxics Controls.** Where numeric objectives have not been established or updated in the Basin Plan, NPDES regulations at 40 CFR §122.44 (d) require that WQBELs be established based on USEPA criteria, supplemented where necessary by other relevant information, to attain and maintain narrative WQOs to fully protect designated beneficial uses.

To determine the need for and establish WQBELs, when necessary, the Regional Water Board staff has followed the requirements of applicable NPDES regulations, including 40 CFR §122 and §131, as well as guidance and requirements established by the Basin Plan; USEPA’s *Technical Support Document for Water Quality-Based Toxics Control* (the TSD, EPA/505/2-90-001, 1991); and the State Water Resources Control Board’s *Policy for Implementation of Toxics Standards for Inland Surface Waters, Enclosed Bays, and Estuaries of California* (the SIP, 2005).

- f. Basin Plan Receiving Water Salinity Policy.** The Basin Plan (like the CTR and the NTR) states that the salinity characteristics (i.e., freshwater vs. saltwater) of the receiving water shall be considered in determining the applicable WQC. Freshwater criteria apply to discharges to waters with salinities equal to or less than one ppt at least 95 percent of the time. Saltwater criteria apply to discharges to waters with salinities equal to or greater than 10 ppt at least 95 percent of the time in a normal water year. For discharges to water with salinities in between these two categories, or tidally influenced freshwaters that support estuarine beneficial uses, the criteria shall be the lower of the salt or freshwater criteria (the latter calculated based on ambient hardness) for each substance.

The receiving water for this Discharger, the Flood Channel is a fresh water environment based on salinity data generated by the Discharger between August 2005 and October 2007. In that period, the salinity was measured below 0.1 ppt 100 percent of the time; therefore, the fresh water criteria from the Basin Plan, NTR, and CTR apply to this discharge.

- g. Site-Specific Metals Translators.** Because NPDES regulations at 40 CFR §122.45 (c) require that effluent limitations for metals be expressed as total recoverable metal, and applicable WQC for metals are typically expressed as dissolved metal, factors or translators must be used to convert metals concentrations from dissolved to total recoverable and vice versa. In the CTR, USEPA establishes default translators that are used in NPDES permitting activities; however, site-specific conditions such as water temperature, pH, suspended solids, and organic carbon greatly impact the form of metal (dissolved, filterable, or otherwise) that is present in the water and therefore available to cause toxicity. In general, the dissolved form of the metals is more available and more toxic to aquatic life than filterable forms. Site-specific translators can be developed to account for site-specific conditions, thereby preventing exceedingly stringent or under protective WQOs.

Because site-specific translators have not been established for the receiving waters for this discharge, in determining the need for and calculating WQBELs for all metals, Regional Water Board staff used default translators established by the USEPA in the CTR at 40 CFR 131.38(b)(2), Table 2.

3. Determining the Need for WQBELs

NPDES regulations at 40 CFR §122.44(d)(1)(i) require permits to include WQBELs for all pollutants (non-priority and priority) “which the Director determines are or may be discharged at a level which will cause, have the reasonable potential to cause, or contribute to an excursion above any narrative or numeric criteria within a State water quality standard.” Thus, assessing whether a pollutant has “Reasonable Potential” is the fundamental step in determining whether or not a WQBEL is required. For non-priority pollutants, Regional Water Board staff used available monitoring data, the receiving water’s designated beneficial uses, and/or previous permit pollutant limitations to determine Reasonable Potential. For priority pollutants, Regional Water Board staff used the methods prescribed in Section 1.3 of the SIP to determine if the discharge demonstrates Reasonable Potential as described below in sections 3.a. – 3.e.

a. Reasonable Potential Analysis

Using the methods prescribed in Section 1.3 of the SIP, Regional Water Board staff analyzed the effluent data to determine if the discharge demonstrates Reasonable Potential. The Reasonable Potential Analysis (RPA) compares the effluent data with numeric and narrative WQOs in the Basin Plan and numeric WQC established by the USEPA in the NTR and CTR. The Basin Plan objectives and CTR criteria are shown in Appendix A of this Fact Sheet.

Note that applicable water quality objectives and criteria for certain metals are hardness dependent. This RPA was conducted using a receiving water hardness of 300 mg/L CaCO₃, which represents the adjusted geometric mean of downstream receiving water hardness measurements taken from August 2005 to October 2007.

b. Reasonable Potential Methodology

Using the methods and procedures prescribed in Section 1.3 of the SIP, Regional Water Board staff analyzed the effluent and background data and the nature of facility operations to determine if the discharge shows a reasonable potential to cause or contribute to exceedances of applicable WQOs or WQC.

The RPA projects a maximum effluent concentration (MEC) for each pollutant based on existing data, while accounting for a limited data set and effluent variability. There are three triggers in determining Reasonable Potential.

- (1) The first trigger is activated if the MEC is greater than or equal to the lowest applicable WQO ($MEC \geq WQO$), which has been adjusted, if appropriate, for pH, hardness, and translator data. If the MEC is greater than or equal to the adjusted WQO, then that pollutant has Reasonable Potential, and a WQBEL is required.
- (2) The second trigger is activated if the observed maximum ambient background concentration (B) is greater than the adjusted WQO ($B > WQO$), and the pollutant is detected in any of the effluent samples ($MEC > ND$).
- (3) The third trigger is activated if a review of other information determines that a WQBEL is required to protect beneficial uses, even though both MEC and B are less than the WQO. A limitation may be required under certain circumstances to protect beneficial uses.

c. Effluent Data

The Regional Water Board's August 6, 2001 letter titled *Requirement for Monitoring of Pollutants in Effluent and Receiving Water to Implement New Statewide Regulations and Policy* (hereinafter referred to as the August 6, 2001 Letter – available online; see Standard Language and Other References Available Online, below) to all permittees, formally required the Discharger (pursuant to Water Code Section 13267) to initiate or continue monitoring for the priority pollutants using analytical methods that provide the best detection limits reasonably feasible. Regional Water Board staff analyzed this effluent data and the nature of the effluent to determine if the discharge has Reasonable

Potential. The RPA was based on effluent monitoring data collected by the Discharger from November 2004 through October 2007 for most inorganic pollutants, and in October 2007 for most organic pollutants.

d. Ambient Background Data

Ambient background values are used in the RPA and in the calculation of effluent limitations. For the RPA, ambient background concentrations are the observed maximum detected water column concentrations. The SIP states that for calculating WQBELs, ambient background concentrations are either the observed maximum ambient water column concentrations or, for criteria/objectives intended to protect human health from carcinogenic effects, the arithmetic mean of observed ambient water concentrations. The Discharger monitored ambient background conditions in the Flood Channel in October 2007 for most of the inorganic (CTR constituent numbers 1-15) and organic (CTR constituent numbers 16-126) toxic pollutants, and these data were used as background data in performing the RPA for this Discharger.

e. Reasonable Potential Determination

The MECs, most stringent applicable WQOs/WQC, and background concentrations used in the RPA are presented in the following table, along with the RPA results (yes or no) for each pollutant analyzed. Reasonable Potential was not determined for all pollutants, as there are not applicable WQOs/WQCs for all pollutants, and monitoring data are not available for others. The RPA results, shown below and in Appendix A of this Fact Sheet, show that there are no pollutants that exhibit Reasonable Potential.

Table F-9. Summary of RPA Results

CTR #	Priority Pollutants	MEC or Minimum DL ⁽¹⁾⁽²⁾ (µg/L)	Governing WQO/WQC (µg/L)	Maximum Background or Minimum DL ⁽¹⁾⁽²⁾ (µg/L)	RPA Results ⁽³⁾
1	Antimony	<0.5	4300	0.61	No
2	Arsenic	1.7	150	2.2	No
3	Beryllium	<0.5	500	<0.5	No
4	Cadmium	<0.25	2.7	<0.25	No
5a	Chromium (III)	<0.5	509	1.8	No
5b	Chromium (VI)	0.31	11	<0.2	No
6	Copper	7.1	24	3.9	No
7	Lead	0.3	13	5.5	No
8	Mercury	0.00171	0.025	0.013	No
9	Nickel	<0.5	132	3.7	No
10	Selenium	<0.5	5	3.4	No
11	Silver	0.18	27	<0.19	No
12	Thallium	<0.5	6.3	<0.5	No
13	Zinc	8.8	304	17	No
14	Cyanide	<2	5.2	<2	No
15	Asbestos	Not Available	No Criteria	Not Available	Ud
16	2,3,7,8-TCDD	<1.0E-6	1.4E-08	<2.3E-6	No
	Dioxin TEQ	<1.0E-6	1.4E-08	4.6E-7	No
17	Acrolein	<1	780	<1	No
18	Acrylonitrile	<1	0.66	<1	No
19	Benzene	<0.5	71	<0.5	No
20	Bromoform	<0.5	360	<0.5	No
21	Carbon Tetrachloride	<0.5	4.4	<0.5	No
22	Chlorobenzene	<0.5	21000	<0.5	No
23	Chlorodibromomethane	<0.5	34	<0.5	No
24	Chloroethane	<1	No Criteria	<1	Ud
25	2-Chloroethylvinyl ether	<2	No Criteria	<2	Ud
26	Chloroform	37.5	No Criteria	0.63	Ud
27	Dichlorobromomethane	1.34	46	<0.5	No
28	1,1-Dichloroethane	<0.5	No Criteria	<0.5	Ud
29	1,2-Dichloroethane	<0.5	99	<0.5	No
30	1,1-Dichloroethylene	<0.5	3.2	<0.5	No
31	1,2-Dichloropropane	<0.5	39	<0.5	No
32	1,3-Dichloropropylene	<0.5	1700	<0.5	No
33	Ethylbenzene	<0.5	29000	<0.5	No
34	Methyl Bromide	<1	4000	<1	No
35	Methyl Chloride	<1	No Criteria	<1	Ud
36	Methylene Chloride	<1	1600	<1	No
37	1,1,2,2-Tetrachloroethane	<0.5	11	<0.5	No
38	Tetrachloroethylene	<0.5	8.9	<0.5	No
39	Toluene	<0.5	200000	<0.5	Ud
40	1,2-Trans-Dichloroethylene	<0.5	140000	<0.5	Ud
41	1,1,1-Trichloroethane	<0.5	No Criteria	<0.5	Ud
42	1,1,2-Trichloroethane	<0.5	42	<0.5	No
43	Trichloroethylene	<0.5	81	<0.5	No
44	Vinyl Chloride	<0.5	525	<0.5	No
45	2-Chlorophenol	<2	400	<2	No
46	2,4-Dichlorophenol	<2	790	<2	No
47	2,4-Dimethylphenol	<4	2300	<4	No
48	2-Methyl- 4,6-Dinitrophenol	<20	765	<20	No
49	2,4-Dinitrophenol	<20	14000	<20	No
50	2-Nitrophenol	<4	No Criteria	<4	Ud

CTR #	Priority Pollutants	MEC or Minimum DL ⁽¹⁾⁽²⁾ (µg/L)	Governing WQO/WQC (µg/L)	Maximum Background or Minimum DL ⁽¹⁾⁽²⁾ (µg/L)	RPA Results ⁽³⁾
51	4-Nitrophenol	<10	No Criteria	<10	Ud
52	3-Methyl 4-Chlorophenol	<2	No Criteria	<2	Ud
53	Pentachlorophenol	<4	8.2	<4	No
54	Phenol	<2	4600000	<2	No
55	2,4,6-Trichlorophenol	<2	6.5	<2	No
56	Acenaphthene	<0.05	2700	<0.05	No
57	Acenaphthylene	<0.05	No Criteria	<0.05	Ud
58	Anthracene	<0.05	110000	<0.05	No
59	Benzidine	<10	0.00054	<10	No
60	Benzo(a)Anthracene	<0.05	0.049	<0.05	No
61	Benzo(a)Pyrene	<0.05	0.049	<0.05	No
62	Benzo(b)Fluoranthene	<0.05	0.049	<0.05	No
63	Benzo(ghi)Perylene	<0.05	No Criteria	<0.05	Ud
64	Benzo(k)Fluoranthene	<2	0.049	<2	No
65	Bis(2-Chloroethoxy)Methane	<2	No Criteria	<2	Ud
66	Bis(2-Chloroethyl)Ether	<2	1.4	<2	No
67	Bis(2-Chloroisopropyl)Ether	<2	170000	<2	No
68	Bis(2-Ethylhexyl)Phthalate	<2	5.9	<2	No
69	4-Bromophenyl Phenyl Ether	<2	No Criteria	<2	Ud
70	Butylbenzyl Phthalate	<2	5200	<2	No
71	2-Chloronaphthalene	<2	4300	<2	No
72	4-Chlorophenyl Phenyl Ether	<5	No Criteria	<5	Ud
73	Chrysene	<2	0.049	<2	No
74	Dibenzo(a,h)Anthracene	<0.05	0.049	<0.05	No
75	1,2-Dichlorobenzene	<0.5	17000	<0.5	No
76	1,3-Dichlorobenzene	<0.5	2600	<0.5	No
77	1,4-Dichlorobenzene	<0.5	2600	<0.5	No
78	3,3 Dichlorobenzidine	<2	0.077	<2	No
79	Diethyl Phthalate	<2	120000	<2	No
80	Dimethyl Phthalate	<2	2900000	<2	No
81	Di-n-Butyl Phthalate	<2	12000	<2	No
82	2,4-Dinitrotoluene	<2	9.1	<2	No
83	2,6-Dinitrotoluene	<2	No Criteria	<2	Ud
84	Di-n-Octyl Phthalate	<2	No Criteria	<2	Ud
85	1,2-Diphenylhydrazine	<2	0.54	<2	No
86	Fluoranthene	<0.05	370	<0.05	No
87	Fluorene	<0.05	14000	<0.05	No
88	Hexachlorobenzene	<2	0.00077	<2	No
89	Hexachlorobutadiene	<2	50	<2	No
90	Hexachlorocyclopentadiene	<2	17000	<2	No
91	Hexachloroethane	<2	8.9	<2	No
92	Indeno(1,2,3-cd)Pyrene	<0.05	0.049	<0.05	No
93	Isophorone	<2	600	<2	No
94	Naphthalene	<0.05	No Criteria	<0.05	Ud
95	Nitrobenzene	<2	1900	<2	No
96	N-Nitrosodimethylamine	<2	8.1	<2	No
97	N-Nitrosodi-n-Propylamine	<2	1.4	<2	No
98	N-Nitrosodiphenylamine	<5	16	<5	No
99	Phenanthrene	<0.05	No Criteria	<0.05	Ud
100	Pyrene	<2	11000	<2	No
101	1,2,4-Trichlorobenzene	<0.5	No Criteria	<0.5	Ud
102	Aldrin	<0.05	0.00014	<0.05	No
103	Alpha-BHC	<0.05	0.013	<0.05	No

CTR #	Priority Pollutants	MEC or Minimum DL ⁽¹⁾⁽²⁾ (µg/L)	Governing WQO/WQC (µg/L)	Maximum Background or Minimum DL ⁽¹⁾⁽²⁾ (µg/L)	RPA Results ⁽³⁾
104	beta-BHC	<0.05	0.046	<0.05	No
105	gamma-BHC	<0.05	0.063	<0.05	No
106	delta-BHC	<0.05	No Criteria	<0.05	Ud
107	Chlordane	<0.5	0.00059	<0.5	No
108	4,4'-DDT	<0.05	0.00059	<0.05	No
109	4,4'-DDE	<0.05	0.00059	<0.05	No
110	4,4'-DDD	<0.05	0.00084	<0.05	No
111	Dieldrin	<0.05	0.00014	<0.05	No
112	Alpha-Endosulfan	<0.05	0.056	<0.05	No
113	beta-Endosulfan	<0.05	0.056	<0.05	No
114	Endosulfan Sulfate	<0.05	240	<0.05	No
115	Endrin	<0.05	0.036	<0.05	No
116	Endrin Aldehyde	<0.05	0.81	<0.05	No
117	Heptachlor	<0.05	0.00021	<0.05	No
118	Heptachlor Epoxide	<0.05	0.00011	<0.05	No
119-125	PCBs sum	<0.2	0.00017	<0.2	No
126	Toxaphene	<1	0.0002	<1	No
	Tributyltin	Not Available	0.0074	Not Available	Ud
	Total PAHs	<0.05	No Criteria	<0.05	Ud
	Ammonia	1200	No Criteria	Not Available	Ud

Footnotes for Table F-9:

- (1) The Maximum Effluent Concentration (MEC) and maximum background concentration are the actual detected concentrations unless preceded by a “<” sign, in which case the value shown is the minimum detection level (DL).
- (2) The MEC or maximum background concentration is “Not Available” when there are no monitoring data for the constituent.
- (3) RPA Results = Yes, if MEC > WQO/WQC, B > WQO/WQC and MEC is detected, or Trigger 3;
= No, if MEC and B are < WQO/WQC or all effluent data are undetected;
= Undetermined (Ud), if no criteria have been promulgated or there are insufficient data.

(1) Constituents with limited data. The Discharger has performed sampling and analysis for the constituents listed in the CTR. This data set was used to perform the RPA. In some cases, Reasonable Potential cannot be determined because effluent data are limited, or ambient background concentrations are not available. The Dischargers will continue to monitor for these constituents in the effluent using analytical methods that provide the best feasible detection limits. When additional data become available, further RPA will be conducted to determine whether to add numeric effluent limitations to this Order or to continue monitoring (VI. Provisions C.2.a.).

(2) Pollutants with no Reasonable Potential. WQBELs are not included in this Order for constituents that do not demonstrate Reasonable Potential; however, monitoring for those pollutants is still required.

Order R2-2003-0051 included final WQBELs for copper and lead; however, because the RPA showed that the discharge no longer demonstrates Reasonable Potential for these pollutants, the effluent limitations for these pollutants are not retained by this Order, and new effluent limitations are not established. Elimination of WQBELs for copper and lead in this Order is consistent with State Water Resources Control Board Order WQ 2001-16.

4. WQBEL Calculations.

WQBELs are developed for the toxic and priority pollutants that were determined to have reasonable potential to cause or contribute to exceedances of the WQOs or WQC. WQBELs are calculated based on appropriate WQOs/WQC and the appropriate procedures specified in Section 1.4 of the SIP. Because the RPA indicated that no pollutant exhibits reasonable potential, WQBELs for toxic pollutants are not calculated and not included in the Order.

5. Whole Effluent Acute Toxicity

a. Permit Requirements

This Order includes effluent limits for whole-effluent acute toxicity. All bioassays shall be performed according to the USEPA approved method in 40 CFR §46, currently “Methods for Measuring the Acute Toxicity of Effluents and Receiving Water to Freshwater and Marine Organisms,” currently 5th Edition. The Discharger is required to use the 5th Edition method for compliance determination upon the effective date of this Order.

b. Ammonia Toxicity

If acute toxicity is observed in the future and the Discharger believes that it is due to ammonia toxicity, this has to be shown through a Toxicity Identification Evaluation (TIE) acceptable to the Executive Officer. If the Discharger demonstrates to the satisfaction of the Executive Officer that exceedance of the acute toxicity limits is caused by ammonia and that the discharge is in compliance with the effluent limit for ammonia, then such toxicity does not constitute a violation of this effluent limit. This is based on the Basin Plan, at Chapter 3 under “Un-Ionized Ammonia.” If ammonia toxicity is verified in the TIE, the Discharger may use an adjustment protocol approved by the Executive Officer for routine bioassay testing.

D. Effluent Limitations

1. Following is a summary of the technology-based and water quality-based effluent limitations established by this Order for Discharge Point 001.

Table F-10. Summary of Final Effluent Limitations

Parameter	Units	Effluent Limitations		
		Average Monthly	Instantaneous Minimum	Instantaneous Maximum
Flow ⁽¹⁾	gallons/day	143,000	---	---
pH ⁽²⁾	standard units	---	6.5	8.5
Total Chlorine Residual ⁽²⁾	mg/L	---	---	0.0

Footnotes for Table F-10:

- (1) Based on a projected increase in the facility production rate of 30 percent
- (2) Based on the Basin Plan

2. Anti-Backsliding Requirements

CWA Sections 402(o)(2) and 303(d)(4) and 40 CFR §122.44(l) prohibit backsliding in NPDES permits. These anti-backsliding provisions require that effluent limitations in a reissued permit must be as stringent as those in the previous permit, with some exceptions in which limitations may be relaxed.

In this Order, limitations for pH, total residual chlorine, and acute toxicity are retained and are unchanged from Order No. R2-2003-0051. By retaining these effluent limitations, they are at least as stringent as those in Order No. R2-2003-0051, thereby meeting anti-backsliding requirements.

Previous limitations for copper and lead are not retained by this Order. Eliminating effluent limits for pollutants that do not show any reasonable potential to cause or contribute to exceedances of water quality standards is consistent with State Water Resources Control Board Order WQ 2001-16.

3. Antidegradation Policy

40 CFR §131.12 sets forth a federal antidegradation policy that aims to (1) maintain and protect existing instream water uses and the level of water quality necessary to protect those existing uses; (2) maintain and protect water quality that exceeds levels necessary to support the propagation of aquatic life, wildlife, and recreation, unless the State finds that allowing lower water quality is necessary to accommodate important economic and social development; (3) maintain and protect the water quality of outstanding National resources, such as waters of National and State parks; and (4) maintain consistency with CWA section 316 where there is potential water quality impairment associated with a thermal discharge.

40 CFR §131.12 also requires that State water quality standards include an antidegradation policy consistent with the federal policy. The State Water Board established California's antidegradation policy in State Water Board Resolution No. 68-16, which incorporates the requirements of the federal antidegradation policy. Resolution 68-16 requires that existing water quality be maintained unless degradation is justified based on specific findings.

This permit includes an increased flow rate, but the increase will not affect the quality of the effluent. The Discharger's treatment infrastructure is sized appropriately to handle the proposed flow rate increase. The existing maximum design treatment capacity of the RO system is 900,000 gallons per day. Therefore, an increase to an average monthly flow rate of 143,000 gallons per day continues to be within the reliable treatment capacity of the RO system.

The effluent limits in this Order are no higher than those authorized in the previous Order. The effluent limits relate to pH and residual chlorine. With respect to chlorine, an increase in flow would not affect receiving water quality because the residual chlorine limit is 0 mg/L.

With respect to pH, the increase in flow would increase the volume of effluent that mixes with Flood Channel water. However, the pH in the Flood Channel upstream of the discharge point is nearly the same as the pH of the effluent (7.95 vs 7.85) and both are within the suitable pH range expressed in the Basin Plan's pH objective (6.5 to 8.5). Therefore, this

additional flow is unlikely to result in any material change in water quality with respect to pH. Thus the increased flow is consistent with antidegradation requirements.

E. Land Discharge Specifications

Not Applicable

F. Reclamation Specifications

Not Applicable

V. RATIONALE FOR RECEIVING WATER LIMITATIONS

A. Receiving Water Limitations V.A. (Surface Water Limitations)

These limitations are in the existing permit and are based on water quality objectives for physical, chemical, and biological characteristics of receiving waters from Chapter 3 of the Basin Plan.

B. Receiving Water Limitations V.B (Groundwater Limitations)

Not Applicable

VI. RATIONALE FOR MONITORING AND REPORTING REQUIREMENTS

The principal purposes of a monitoring program are to:

- (a) Document compliance with waste discharge requirements and prohibitions established by the Regional Water Board;
- (b) Facilitate self-policing by the discharger in the prevention and abatement of pollution arising from waste discharge;
- (c) Develop or assist in the development of limitations, discharge prohibitions, national standards of performance, pretreatment and toxicity standards, and other standards; and
- (d) Prepare water and wastewater quality inventories.

The MRP (Attachment E) is a standard requirement in almost all NPDES permits issued by the Regional Water Board, including this Order. It contains definitions of terms, specifies general sampling and analytical protocols, and sets out requirements for reporting of spills, violations, and routine monitoring data in accordance with NPDES regulations, the California Water Code, and Regional Water Board policies. The MRP also defines the sampling stations and frequency, the pollutants to be monitored, and additional reporting requirements. Pollutants to be monitored include all parameters for which effluent limitations are specified. Monitoring for additional constituents, for which no effluent limitations are established, is also required to provide data for future completion of RPAs for them.

A. Influent Monitoring

Influent monitoring requirements for flow rate and observations of the sodium metabisulfite pumps and tanks are retained from the previous Order. Monitoring requirements for the sodium metabisulfite system provide assurance to the Regional Water Board that the dechlorination system is properly maintained and operated.

B. Effluent Monitoring

The MRP retains most effluent monitoring requirements from the previous permit. Changes in effluent monitoring are summarized as follows.

- (1) Monthly monitoring of copper and lead is no longer required because the effluent limitation for these parameters are not retained by this Order.
- (2) Quarterly monitoring of silver and zinc and annual monitoring of mercury are no longer required because these pollutants did not show reasonable potential and, as priority pollutants, they will be monitored as part of the priority pollutant monitoring required by the MRP.
- (3) A requirement to monitor as described in the August 6, 2001 Letter for the full suite of priority pollutants once during the term of the permit has been established by this Order.

C. Receiving Water Monitoring

The requirement to conduct receiving water monitoring is based on the Basin Plan and the SIP. Receiving water monitoring is necessary because water quality objectives for a number of pollutants depend on the ambient hardness of the receiving water. Receiving water monitoring requirements for priority pollutants are also based in the August 6, 2001 Letter.

D. Other Monitoring Requirements

Not Applicable

VII. RATIONALE FOR PROVISIONS

A. Standard Provisions (Provision VI.A)

Standard Provisions, which in accordance with 40 CFR §122.41 and §122.42 apply to all NPDES discharges and must be included in every NPDES permit, are provided in Attachments D of this Order.

NPDES regulations at 40 CFR §122.41(a)(1) and (b) through (n) establish conditions that apply to all State-issued NPDES permits. These conditions must be incorporated into the permits either expressly or by reference. If incorporated by reference, a specific citation to the regulations must be included in this Order. 40 CFR §123.25(a)(12) allows the State to omit or modify conditions to impose more stringent requirements. In accordance with 40 CFR §123.25, this Order omits federal conditions that address enforcement authority specified at 40 CFR §122.41(j)(5) and (k)(2) because the enforcement authority under the Water Code is more stringent. In lieu of these conditions, this Order incorporates by reference Water Code 13387(e). Other standard provisions imposed by the Regional Water Board are in Attachment G.

B. Monitoring and Reporting Requirements (Provision VI.B)

The Discharger is required to conduct monitoring of the permitted discharges in order to evaluate compliance with permit conditions. Monitoring requirements are contained in the MRP (Attachment E), Standard Provisions, and SMP, Part A (Attachment G). This provision requires compliance with these documents and is based on 40 CFR §122.63. The Standard Provisions and SMP, Part A are standard requirements in almost all NPDES permits issued by the Regional Water Board, including this Order. They contain definitions of terms, specify general sampling and analytical protocols, and set out requirements for reporting of spills, violations, and routine monitoring data in accordance with NPDES regulations, the California Water Code, and Regional Water Board policies.

C. Special Provisions (Provision VI.C)

1. Reopener Provisions

These provisions are based on 40 CFR §123 and allow future modification of this Order and its effluent limitations as necessary.

2. Special Studies and Additional Monitoring Requirements

- a. Effluent Characterization Study.** This Order does not include effluent limitations for selected constituents addressed in the August 6, 2001 Letter; however, this provision requires the Discharger to continue monitoring for those pollutants. The requirements of this Effluent Characterization Study are repeated in this Order as monitoring requirements established in section IV.A. of the MRP. This provision is based on the Basin Plan and the SIP. These data are needed to undertake further reasonable potential analyses.
- b. Ambient Background Receiving Water Study.** This provision is based on the Basin Plan, the SIP, and the August 6, 2001 Letter regarding priority pollutant monitoring. The requirements of this Ambient Background Receiving Water Study are repeated in section VIII.A. of the MRP.

3. Construction, Operation, and Maintenance Specifications

- a. Wastewater Facilities, Review and Evaluation, and Status Reports.** This provision is established by this Order, and is based in the Basin Plan.
- b. Operations and Maintenance Manual, Review and Status Reports.** This provision is based on the Basin Plan, the requirements of 40 CFR §122, and the previous Order. See Section VI.C.4 of this Order for specific requirements.
- c. Contingency Plan:** The Discharger is not required to maintain a Contingency Plan. The Executive Officer granted a request by the Discharger prior to the adoption of the previous permit to remove this requirement. The Executive Officer granted the request because the most likely failure is a power outage, which would result in a cessation of discharge and would not pose a threat to water quality. Therefore, a Contingency Plan is unnecessary.

4. Other Special Provisions

- a. Changes in Control or Ownership.** This provision for notification of the succeeding owner of the existence of this Order, and the Executive Officer of the transfer, is retained from the previous permit.
- b. Storm Water Requirements.** This provision requires the Discharger to seek coverage for storm water discharges under the general permit, if applicable.

VIII. PUBLIC PARTICIPATION

The California Regional Water Quality Control Board, the San Francisco Bay Regional Water Board, is considering the issuance of WDRs that will serve as a NPDES permit for this discharge. As a step in the WDR adoption process, the Regional Water Board staff developed tentative WDRs. The Regional Water Board encourages public participation in the WDR adoption process.

A. Notification of Interested Parties

The Regional Water Board notified the Dischargers and interested agencies and persons of its intent to prescribe waste discharge requirements for the discharge and provided them with an opportunity to submit their written comments and recommendations. Notification was provided through the following public notice in the The Daily Review on, or around, May 9, 2008.

B. Written Comments

Staff determinations are tentative. Interested persons are invited to submit written comments concerning the tentative WDRs. Comments must be submitted either in person or by mail to the Regional Water Board at the address above on the cover page of this Order, Attention: Adrienne Miller.

To be fully responded to by staff and considered by the Regional Water Board, written comments should be received at the Regional Water Board offices by 5:00 p.m. on May 30, 2008.

C. Public Hearing

The Regional Water Board will hold a public hearing on the tentative WDRs during its regular Board meeting on the following dates and time and at the following location:

Dates: July 8 and 9, 2008
Time: 9:00 am
Location: Elihu Harris State Office Building
1515 Clay Street, 1st Floor Auditorium
Oakland, CA 94612

Interested persons are invited to attend. At the public hearing, the Regional Water Board will hear testimony, if any, pertinent to the discharge, WDRs, and permit. Oral testimony will be heard; however, for accuracy of the record, important testimony should be in writing.

Please be aware that dates and venues may change. The Regional Water Board's Webpage, <http://www.waterboards.ca.gov/sanfranciscobay>, contains the current agenda and any changes in dates and locations.

D. Waste Discharge Requirements Petitions

Any aggrieved person may petition the State Water Resources Control Board to review the decision of the Regional Water Board regarding the final WDRs. The petition must be submitted within 30 days of the Regional Water Board's action to the following address:

State Water Resources Control Board
Office of Chief Counsel
P.O. Box 100, 1001 I Street
Sacramento, CA 95812-0100

E. Information and Copying

The Report of Waste Discharge, related documents, tentative effluent limitations and special provisions, comments received, and other information are on file and may be inspected at the address above at any time between 8:30 a.m. and 4:45 p.m., except from noon to 1:00 p.m., Monday through Friday. Copying of documents may be arranged through the Regional Water Board by calling 510-622-2300.

F. Register of Interested Persons

Any person interested in being placed on the mailing list for information regarding the WDRs and NPDES permits should contact the Regional Water Board, reference this facility, and provide a name, address, and phone number or sign up for email notifications at http://www.waterboards.ca.gov/lyrisforms/reg2_subscribe

G. Additional Information

Requests for additional information or questions regarding this order should be directed to Adrienne Miller at 510-622-2415 or admiller@waterboards.ca.gov.