



Linda S. Adams  
Secretary for  
Environmental Protection

# California Regional Water Quality Control Board

## San Francisco Bay Region

1515 Clay Street, Suite 1400, Oakland CA 94612  
(510) 622-2300 • Fax (510) 622-2460  
<http://www.waterboards.ca.gov/sanfranciscobay>



Arnold Schwarzenegger  
Governor

### ORDER NO. R2-2009-xxxx NPDES NO. CA0005550

The following Discharger is subject to waste discharge requirements as set forth in this Order.

**Table 1. Discharger Information**

<b>Discharger</b>	<b>Valero Refining Company - California</b>
<b>Name of Facility</b>	Valero Benicia Refinery
<b>Facility Address</b>	3400 East Second Street
	Benicia, CA 94510
	Solano County
The United States Environmental Protection Agency (USEPA) and the Regional Water Quality Control Board have classified this discharge as a major discharge.	

Discharges by the Valero Benicia Refinery from the discharge points identified below are subject to waste discharge requirements as set forth in this Order.

**Table 2. Discharge Location**

Discharge Point	Effluent Description	Discharge Point Latitude	Discharge Point Longitude	Receiving Water
001	Treated refinery wastewater	38°, 03', 18" N	122°, 07', 07" W	Suisun Bay
002	Storm water from 1.8 acres, discharged at NW corner of WWTP area	38°, 03', 53" N	122°, 07', 37" W	Suisun Bay
003	Storm water from refinery property and Lower Level Tank Farm, 85.6 acres total, discharged at north end of Avenue A to Sulfur Springs Creek	38°, 04', 49" N	122°, 08', 12" W	Suisun Bay
004	Storm water from 0.5 acre gravel area between 1st Street and railway on south side of 1st Street, discharged west of Gate 4 into eastern end of Beaver Creek	38°, 03', 59" N	122°, 07', 58" W	Suisun Bay
005	Storm water from 68.9 acres west of processing area, discharged west of Gate 4 into western end of Beaver Creek	38°, 03', 58" N	122°, 08', 05" W	Suisun Bay
006	Storm water from 35.5 acres beneath the refinery crude pipeline, including the Crude Oil Storage Area (COSA) tank farm, discharged on the south side of Park Road to Sulfur Springs Creek	38°, 03', 50" N	122°, 07', 57" W	Suisun Bay
007	Storm water from 0.7 acre gravel and paved area near Gate 4, discharged east of Gate 4 to Buffalo Wallow	38°, 04', 02" N	122°, 07', 54" W	Suisun Bay

Discharge Point	Effluent Description	Discharge Point Latitude	Discharge Point Longitude	Receiving Water
008	Storm water from 0.9 acre gravel area along the railway and the refinery fence line, discharged east of Gate 4 to Buffalo Wallow	38°, 04', 02" N	122°, 07', 53" W	Suisun Bay
009	Storm water from 0.3 acre gravel and paved area between the railway and Avenue A and adjacent to the Upper Level Tank Farm (ULTF), discharged on the SE side of the processing area to Sulfur Springs Creek	38°, 04', 12" N	122°, 07', 53" W	Suisun Bay
010	Storm water from 63.8 acre gravel and paved area between the railway and Avenue A and adjacent to the ULTF, discharged on the SE side of the processing area to Sulfur Springs Creek	38°, 04', 12" N	122°, 07', 53" W	Suisun Bay
011	Storm water from 0.4 acres beneath the refinery crude pipeline on the north side of Park Road, discharged on the north side of Park Road to Sulfur Springs Creek	38°, 03', 52" N	122°, 07', 57" W	Suisun Bay
016	Storm water from 0.1 acres beneath the refinery crude pipeline south of Outfall 15 near the refinery dock, discharged via culvert to Carquinez Strait	38°, 02', 44" N	122°, 07', 45" W	Carquinez Strait
017	Storm water from approximately 12 acres at the Asphalt Plant, collected in a holding tank before discharge to Buffalo Wallow	38°, 03', 58" N	122°, 08', 05" W	Suisun Bay

**Table 3. Administrative Information**

This Order was adopted by the Regional Water Board on:	<b>November 18, 2009</b>
This Order shall become effective on:	<b>January 1, 2010</b>
This Order shall expire on:	<b>December 31, 2015</b>
The Discharger shall file a Report of Waste Discharge in accordance with Title 23, California Code of Regulations, as application for issuance of new waste discharge requirements no later than:	<b><u>180 days prior to the Order expiration date</u></b>

I, Bruce H. Wolfe, Executive Officer, do hereby certify that this Order with all attachments is a full, true, and correct copy of an Order adopted by the California Regional Water Quality Control Board, San Francisco Bay Region, on November 18, 2009.

\_\_\_\_\_  
Bruce H. Wolfe, Executive Officer

## Table of Contents

I.	Facility Information .....	5
II.	Findings.....	5
III.	Discharge Prohibitions.....	10
IV.	Effluent Limitations and Discharge Specifications .....	12
	A. Effluent Limitations – Discharge Point 001 .....	12
	B. Storm Water Effluent Limitations - Discharge Points 002 – 011 and 016 - 017 .....	16
	C. Land Discharge Specifications.....	16
	D. Reclamation Specifications .....	16
V.	Receiving Water Limitations .....	17
VI.	Provisions.....	17
	A. Standard Provisions.....	17
	B. Monitoring and Reporting Program (MRP) Requirements .....	18
	C. Special Provisions .....	18
	1. Reopener Provisions.....	18
	2. Special Studies and Additional Monitoring .....	18
	3. Best Management Practices and Pollution Minimization .....	21
	4. Other Special Provisions .....	23

## Tables

Table 1.	Discharger Information .....	1
Table 2.	Discharge Location.....	1
Table 3.	Administrative Information .....	2
Table 4.	Facility Information.....	5
Table 5.	Beneficial Uses of Receiving Waters.....	8
Table 6a.	Effluent Limitations at Production Rate of 135,000 bbls/d.....	12
Table 6b.	Effluent Limitations at Production Rate of 165,000 bbls/d.....	12
Table 7.	Effluent Limitations for Toxic Substances.....	13
Table 8.	Minimum Levels for Pollutants with Effluent Limitations .....	13
Table 9.	Interim Effluent Limitations.....	14
Table 10.	Selenium Mass Emission Limitation.....	14
Table 11.	Effluent Limitations for Storm Water Outfalls .....	16
Table 12.	Supplemental Effluent Limitations for Storm Water Outfalls .....	16
Table 13.	Receiving Waters and Effluent Selenium Characterization Study Tasks and Schedule .....	20
Table 14.	Cyanide Action Plan.....	23
Table 15.	Copper Action Plan .....	24
Table 16.	Dioxin-TEQ Compliance Schedule.....	25

**Attachments**

Attachment A – Definitions ..... A-1  
Attachment B – Facility Map..... B-1  
Attachment C – Process Flow Diagram..... C-1  
Attachment D – Federal Standard Provisions..... D-1  
Attachment E – Monitoring and Reporting Program (MRP)..... E-1  
Attachment F – Fact Sheet..... F-1  
Attachment G – Regional Standard Provisions, and Monitoring and Reporting Requirements  
(Supplement To Attachment D)..... G-1

## I. FACILITY INFORMATION

The following Discharger is subject to the waste discharge requirements as set forth in this Order:

**Table 4. Facility Information**

<b>Discharger</b>	Valero Refining Company – California
<b>Name of Facility</b>	Valero Benicia Refinery
<b>Facility Address</b>	3400 East Second Street
	Benicia, CA 94510
	Solano County
<b>Facility Contact, Title, Phone No.</b>	Marcus Cole, Environmental Engineer, (707) 745-7807
<b>Mailing Address</b>	3400 East Second Street, Benicia, CA 94510
<b>Type of Facility</b>	Petroleum Refinery
<b>Average Facility Flow (2008)</b>	1.93 million gallons per day (MGD)

## II. FINDINGS

The California Regional Water Quality Control Board, San Francisco Bay Region (hereinafter Regional Water Board), finds:

**A. Background.** The Valero Refining Company - California (hereinafter Discharger) currently discharges under Order No. 2002-0112 (hereinafter previous permit) and National Pollutant Discharge Elimination System (NPDES) Permit No. CA0005550. The Discharger submitted a Report of Waste Discharge dated May 31, 2007, and applied for reissuance of its NPDES permit to discharge treated wastewater from the Valero Benicia Refinery. The Discharger's discharge is also currently under Order No. 2008-0077 (NPDES Permit CA0038849) that superseded all requirements on mercury from wastewater discharges in the region. The mercury permit is unaffected by this Order.

For purposes of this Order, references to the “discharger” or “permittee” in applicable federal and State laws, regulations, plans, or policies are held to be equivalent to references to the Discharger herein.

**B. Facility Description.** The Discharger owns and operates a petroleum refinery that processes an average crude oil volume of approximately 135,000 barrels per day (bbls/d), producing hydrocarbon products, byproducts, and intermediates. The average volume of crude oil processed is expected to increase to 165,000 bbls/d during the term of this Order, which would result in increased discharges of process wastewater.

Wastewaters treated by the refinery's wastewater treatment plant include stripped sour water, cooling tower and boiler blowdown water, crude water draw from on-site and off-site storage facilities, raw water treatment backwash, ballast water, storm water runoff from process areas, extracted groundwater from on-site remediation processes, and monitoring well purge water from off-site service stations owned by the Discharger. All process wastewater and storm water from the refinery asphalt plant is discharged to the City of Benicia sanitary sewer system and is therefore not regulated by this Order.

Wastewater is first treated by corrugated plate separators (CPS) and induced static flotation (ISF) units to remove oils and solids. Most of the non-oily waste stream from the sour water stripper is pretreated in two activated sludge (pre-Biox) units. The remaining stripped sour water is combined with oily waste streams and the pre-Biox effluent. The combined wastewater is then treated by an activated sludge (Biox) system consisting of three aeration basins and three clarifiers operated in parallel, with an addition of powdered activated carbon. The wastewater stream then flows to an induced air flotation (IAF) unit for additional solids removal. From the IAF unit, wastewater flows to a reactor clarifier, where ferric chloride is added to co-precipitate selenite and polymer is added to enhance flocculation. Sodium hydroxide is added to adjust the pH of the reactor clarifier effluent, which is sent to the final sump/pond (final pond). The final pond is unlined and has a capacity of approximately 2.4 million gallons (MG). It provides some flow equalization for the discharge pumps. Treated effluent is pumped from the final pond to Discharge Point 001 and discharged through a submerged diffuser to Suisun Bay, a water of the State and United States.

When analysis of treated wastewater at the final pond indicates that it may violate effluent limitations, discharge to Suisun Bay is halted and the effluent is pumped to the crude field retention pond, which has a capacity of 23 MG. Effluent stored in the crude field retention pond is returned to the wastewater treatment plant for full or partial treatment or, if monitoring indicates that effluent limits are met, is returned to the final pond for discharge.

The refinery also has several storm water discharge points to Suisun Bay and Carquinez Strait (Discharge Points 002 – 017). Discharges from certain areas near the Discharger's crude tank field and under the Discharger's crude pipeline (designated Discharge Points 012 through 015) that discharge to the City of Benicia sanitary sewer system are not regulated by this Order, and are instead regulated by the City.

During the term of the previous permit, accumulated storm water from 162 acres in the Refinery Tank Farm and Crude Oil Storage Area was routed to the refinery wastewater treatment plant for treatment and discharge via Discharge Point 001. During the term of this Order, the Discharger will modify the refinery's drainage system to route storm water from the Refinery Tank Farm and Crude Oil Storage Area to Discharge Points 003, 006, 009, and 010. This will reduce hydraulic loading to the wastewater treatment plant and thus enhance pollutant removal. Internal monitoring prior to discharge from these areas is required by section VI.C.2.e of this Order. The refinery will retain the ability to route these storm water flows to the wastewater treatment plant. This is discussed further in Fact Sheet section II.A.

When influent flow rates to the treatment plant are greater than 2,600 gallons per minute (gpm) because of a storm event, and the surge and equalization tanks are full, influent can be diverted to storm water retention ponds. These storm water retention ponds are unlined with a capacity of 18 MG, enough for storm water from a 20-year storm. This storm water is later run through the wastewater treatment plant, entering just upstream of the activated sludge unit.

Attachment B to this Order is a Location Map showing the location of the Benicia Refinery within the Region; and Attachment C is a flow schematic of the plant.

- C. Legal Authorities.** This Order is issued pursuant to Clean Water Act (CWA) section 402 and implementing regulations adopted by the USEPA, and California Water Code (CWC) Chapter 5.5, Division 7, commencing with section 13370. It shall serve as an NPDES permit for the point source

discharges identified in Table 2. This Order also serves as Waste Discharge Requirements (WDRs) pursuant to CWC Article 4, Chapter 4, Division 7, commencing with section 13260.

- D. Background and Rationale for Requirements.** The Regional Water Board developed the requirements in this Order based on information submitted as part of the application, through monitoring and reporting programs, and other available information. The Fact Sheet (Attachment F), which contains background information and rationale for Order requirements, is hereby incorporated into this Order and constitutes part of the Findings for this Order. Attachments A through E and G are also incorporated into this Order.
- E. California Environmental Quality Act (CEQA).** Pursuant to CWC section 13389, this action to adopt an NPDES permit is exempt from the provisions of CEQA.
- F. Technology-Based Effluent Limitations.** CWA section 301(b) and 40 CFR 122.44 require permits, at a minimum, to include conditions meeting applicable technology-based requirements and any more stringent effluent limitations necessary to meet applicable water quality standards. Discharges authorized by this Order must meet technology-based requirements USEPA established at 40 CFR 419, *Effluent Limitations Guidelines for the Petroleum Refining Point Source Category*, as well as technology-based requirements established using Best Professional Judgment (BPJ) pursuant to 40 CFR 125.3. A detailed discussion of the development of the technology-based effluent limitations in this Order is included in the Fact Sheet.
- G. Water Quality-Based Effluent Limitations.** CWA section 301(b) and 40 CFR 122.44(d) require that permits include limitations more stringent than applicable federal technology-based requirements when necessary to achieve applicable water quality standards.

40 CFR 122.44(d)(1)(i) mandate that permits include effluent limitations for all pollutants that are or may be discharged at levels that have a reasonable potential to cause or contribute to an exceedance of a water quality standard, including numeric and narrative objectives within a standard. Where reasonable potential has been established for a pollutant, but there is no numeric objective for the pollutant, water quality-based effluent limitations (WQBELs) must be established using (1) USEPA criteria guidance under CWA section 304(a), supplemented where necessary by other relevant information; (2) an indicator parameter for the pollutant of concern; or (3) a calculated numeric water quality criterion, such as a proposed State criterion or policy interpreting the State's narrative criterion, supplemented with other relevant information, as provided in 40 CFR 122.44(d)(1)(vi).

- H. Water Quality Control Plans.** *The Water Quality Control Plan for the San Francisco Bay Basin* (Basin Plan) is the Regional Water Board's master water quality control planning document. It designates beneficial uses and water quality objectives for waters of the State, including surface waters and groundwater. It also includes programs of implementation to achieve water quality objectives. The Basin Plan was adopted by the Regional Water Board and approved by the State Water Resources Control Board (State Water Board), USEPA, and the Office of Administrative Law, as required. Beneficial uses described by the Basin Plan and applicable to Suisun Bay and Carquinez Strait are listed in Table 5. Requirements of this Order implement the Basin Plan.

**Table 5. Beneficial Uses of Receiving Waters**

Discharge Point	Receiving Water Name	Beneficial Uses
001, 002, 003, 004, 005, 006, 007, 008, 009, 010, 011, 017 <sup>[1]</sup>	Suisun Bay	Ocean, Commercial and Sport Fishing (COMM) Industrial Process Supply (PRO) Estuarine Habitat (EST) Industrial Service Supply (IND) Fish Migration (MIGR) Navigation (NAV) Preservation of Rare and Endangered Species (RARE) Water Contact Recreation (REC1) Non-Contact Water Recreation (REC2) Wildlife Habitat (WILD) Fish Spawning (SPWN)
016	Carquinez Strait	Ocean, Commercial and Sport Fishing (COMM) Estuarine Habitat (EST) Industrial Service Supply (IND) Fish Migration (MIGR) Navigation (NAV) Preservation of Rare and Endangered Species (RARE) Water Contact Recreation (REC1) Non-Contact Water Recreation (REC2) Wildlife Habitat (WILD) Fish Spawning (SPWN)

<sup>[1]</sup> Outfalls 002 through 011, and 017 flow to specific creeks, which flow to Suisun Bay. Beneficial uses of Suisun Bay apply to these creeks due to the Tributary Rule.

- I. National Toxics Rule (NTR) and California Toxics Rule (CTR).** USEPA adopted the NTR on December 22, 1992, and later amended it on May 4, 1995, and November 9, 1999. About forty criteria in the NTR applied in California. On May 18, 2000, USEPA adopted the CTR. The CTR promulgated new toxics criteria for California and, in addition, incorporated the previously adopted NTR criteria that applied in the State. The CTR was amended on February 13, 2001. These rules contain water quality criteria for priority pollutants.
- J. State Implementation Policy.** On March 2, 2000, the State Water Board adopted the *Policy for Implementation of Toxics Standards for Inland Surface Waters, Enclosed Bays, and Estuaries of California* (State Implementation Policy or SIP). The SIP became effective on April 28, 2000, with respect to the priority pollutant criteria USEPA promulgated for California through the NTR and to the priority pollutant objectives the Regional Water Board established in the Basin Plan. The SIP became effective on May 18, 2000, with respect to the priority pollutant criteria the USEPA promulgated through the CTR. On February 24, 2005, the State Water Board adopted amendments to the SIP that became effective on July 13, 2005. The SIP establishes implementation provisions for priority pollutant objectives and provisions for chronic toxicity control. Requirements of this Order implement the SIP.
- K. Compliance Schedules and Interim Requirements.** SIP section 2.1 provides that, based on an existing discharger's request and demonstration that it is infeasible for it to achieve immediate compliance with an effluent limitation derived from a CTR criterion, compliance schedules may be allowed in an NPDES permit. The State Water Board adopted Resolution No. 2008-0025 on April



15, 2008, titled *Policy for Compliance Schedules in National Pollutant Discharge Elimination System Permits*, which includes compliance schedule policies for pollutants that are not addressed by the SIP. This policy has been approved by OAL and USEPA, and became effective on August 27, 2008. Where a compliance schedule for a final effluent limitation exceeds 1 year, permits must include an interim numeric limitation for that pollutant. Where allowed by the Basin Plan, compliance schedules and interim effluent limitations or discharge specifications may also be granted to allow time to implement a new or newly interpreted narrative water quality objective. This Order includes a compliance schedule and interim effluent limitation. A detailed discussion of the basis for the compliance schedule is included in the Fact Sheet.

**L. Alaska Rule.** On March 30, 2000, USEPA revised its regulation that specifies when new and revised State and tribal water quality standards become effective for CWA purposes [65 Fed. Reg. 24641 (April 27, 2000) (codified at 40 CFR 131.21)]. Under the revised regulation (also known as the Alaska Rule), USEPA must approve new and revised standards submitted to USEPA after May 30, 2000, before they can be used for CWA purposes. The final rule also provides that standards already in effect and submitted to USEPA by May 30, 2000, may be used for CWA purposes, whether or not approved by USEPA.

**M. Stringency of Requirements for Individual Pollutants.** This Order contains both technology-based effluent limitations and water quality-based effluent limitations (WQBELs) for individual pollutants. The technology-based effluent limitations consist of restrictions on biochemical oxygen demand (BOD<sub>5</sub>), oil and grease, pH, total suspended solids (TSS), chemical oxygen demand (COD), ammonia, sulfide, 4-aminoantipyrine (4AAP) phenolics, and total and hexavalent chromium. Derivation of these technology-based limitations is discussed in the Fact Sheet (Attachment F). This Order's technology-based pollutant restrictions implement the minimum applicable federal technology-based requirements. In addition, this Order contains effluent limitations more stringent than the minimum federal technology-based requirements as necessary to meet water quality standards. These limitations are not more stringent than required by the CWA.

WQBELs have been derived to implement water quality objectives that protect beneficial uses. Both the beneficial uses and the water quality objectives have been approved pursuant to federal law and are the applicable federal water quality standards. To the extent that toxic pollutant WQBELs were derived from the CTR, the CTR is the applicable standard pursuant to 40 CFR 131.38. The procedures for calculating the individual WQBELs for priority pollutants are based on the SIP, which was approved by USEPA on May 18, 2000. All beneficial uses and water quality objectives in the Basin Plan were approved under State law and submitted to and approved by USEPA prior to May 30, 2000. Any water quality objectives and beneficial uses submitted to and approved by USEPA prior to May 30, 2000, but not approved by USEPA before that date, are nonetheless applicable water quality standards for purposes of the CWA pursuant to 40 CFR 131.21(c)(1). Collectively, this Order's restrictions on individual pollutants are no more stringent than required to implement CWA requirements.

**N. Antidegradation Policy.** 40 CFR 131.12 requires that state water quality standards include an antidegradation policy consistent with the federal policy. The State Water Board established California's antidegradation policy through State Water Board Resolution No. 68-16, which incorporates the federal antidegradation policy where the federal policy applies under federal law and requires that the existing quality of receiving waters be maintained unless degradation is justified based on specific findings. The Basin Plan incorporates by reference and implements both

the State and federal antidegradation policies. As discussed in the Fact Sheet, the permitted discharges are consistent with the antidegradation provisions of 40 CFR 131.12 and State Water Board Resolution No. 68-16.

- O. Anti-Backsliding Requirements.** CWA sections 402(o)(2) and 303(d)(4) and 40 CFR 122.44(l) prohibit backsliding in NPDES permits. These anti-backsliding provisions require effluent limitations in a reissued permit to be at least as stringent as those in the previous permit, with some exceptions where limitations may be relaxed. Some effluent limitations in this Order are less stringent than those in the previous permit. As discussed in the Fact Sheet, this relaxation of effluent limitations is consistent with the CWA anti-backsliding requirements and federal regulations.
- P. Monitoring and Reporting.** 40 CFR 122.48 require that all NPDES permits specify requirements for recording and reporting monitoring results. CWC sections 13267 and 13383 authorize the Regional Water Board to require technical and monitoring reports. The Monitoring and Reporting Program, which is provided in Attachment E, establishes monitoring and reporting requirements to implement federal and State requirements.
- Q. Standard and Special Provisions.** Standard Provisions, which apply to all NPDES permits in accordance with 40 CFR 122.41, and additional conditions applicable to specified categories of permits in accordance with 40 CFR 122.42, are provided in Attachment D. The Discharger must comply with all standard provisions and with those additional conditions that apply pursuant to 40 CFR 122.42. The Regional Water Board has also included in this Order special provisions applicable to the Discharger. Rationales for the special provisions in this Order are provided in the attached Fact Sheet.
- R. Provisions and Requirements Implementing State Law.** No provisions of this Order implement State law only. All are required or authorized under the federal CWA and CWC. The Regional Standard Provisions are included as Attachment G.
- S. Notification of Interested Parties.** The Regional Water Board has notified the Discharger and interested agencies and persons of its intent to prescribe Waste Discharge Requirements for the discharge and has provided them with an opportunity to submit written comments and recommendations. Details of the notification are provided in the Fact Sheet.
- T. Consideration of Public Comment.** The Regional Water Board, in a public meeting, heard and considered all comments pertaining to the discharges authorized by this Order. Details of the Public Hearing are provided in the Fact Sheet.

IT IS HEREBY ORDERED, that this Order supersedes Order No. 2002-0112, except for enforcement purposes, and in order to meet the provisions in CWC Division 7 (commencing with section 13000) and regulations adopted thereunder, and the provisions of the federal Clean Water Act (CWA) and regulations and guidelines adopted thereunder, the Discharger shall comply with the requirements in this Order.

### III. DISCHARGE PROHIBITIONS

- A.** Discharge of wastewater at a location or in a manner different from that described in this Order is prohibited.

- B** Discharge of process wastewater at any point at which it does not receive an initial dilution of at least 15:1 is prohibited.
  
- C** The bypass of untreated or partially treated process wastewater to waters of the United States is prohibited, except as provided for in the conditions stated in I.G.2 of Attachment D to this Order.

**IV. EFFLUENT LIMITATIONS AND DISCHARGE SPECIFICATIONS****A. Effluent Limitations – Discharge Point 001****1. Technology-Based Effluent Limitations**

- a. The Discharger shall maintain compliance with the following effluent limitations at Discharge Point 001, with compliance measured at Monitoring Location EFF-001 as described in the attached MRP (Attachment E), until it has received written notice from the Executive Officer of its satisfactory compliance with the requirements under VI.C.5.c of this Order justifying the alternate limitations specified in A.1.b, below.

**Table 6a. Effluent Limitations at Production Rate of 135,000 bbls/d**

Parameter	Units	Effluent Limitations	
		Average Monthly	Maximum Daily
BOD <sub>5</sub>	lbs/day	1800	3300
	kg/day	830	1500
COD	lbs/day	13000	25000
	kg/day	5800	11000
TSS	lbs/day	1500	2300
	kg/day	660	1040
Oil & Grease	lbs/day	530	995
	kg/day	240	450
Phenolic Compounds	lbs/day	12	25
	kg/day	5.4	11
Ammonia (N)	lbs/day	995	2200
	kg/day	450	1000
Sulfide	lbs/day	9.6	22
	kg/day	4.4	9.8
Settleable Solids	mL/L/hr	0.1	0.2
Total Chromium	lbs/day	18	50
	kg/day	8.2	23
Hexavalent Chromium	lbs/day	1.5	3.3
	kg/day	0.67	1.5
pH	s.u.	6.0- 9.0 at all times	

- b. When the refinery production rate is 165,000 bbls/d, the Discharger shall maintain compliance with the following effluent limitations at Discharge Point 001, with compliance measured at Monitoring Location EFF-001 as described in the attached MRP (Attachment E). These effluent limitations shall become effective following satisfaction of the requirements of section VI.C.5.c of this Order.

**Table 6b. Effluent Limitations at Production Rate of 165,000 bbls/d**

Parameter	Units	Effluent Limitations	
		Average Monthly	Maximum Daily
BOD <sub>5</sub>	lbs/day	2000	3500
	kg/day	890	1600
COD	lbs/day	14000	26000

Parameter	Units	Effluent Limitations	
		Average Monthly	Maximum Daily
TSS	kg/day	6200	12000
	lbs/day	1600	2500
	kg/day	710	1100
Oil & Grease	lbs/day	570	1100
	kg/day	260	490
Phenolic Compounds	lbs/day	13	26
	kg/day	5.8	12
Ammonia (N)	lbs/day	1100	2400
	kg/day	490	1100
Sulfide	lbs/day	10	23
	kg/day	4.7	11
Settleable Solids	mL/L-hr	0.1	0.2
Total Chromium	lbs/day	18	53
	kg/day	8.3	24
Hexavalent Chromium	lbs/day	1.5	3.4
	kg/day	0.68	1.5
pH	s.u.	6.0 – 9.0 at all times	

## 2. Effluent Limitations for Toxics Substances

- a. The Discharger shall maintain compliance with the following effluent limitations at Discharge Point 001, with compliance measured at Monitoring Location EFF-001 as described in the attached MRP (Attachment E):

**Table 7. Effluent Limitations for Toxic Substances** <sup>[1]</sup>

Parameter	Units	Final Effluent Limitations	
		Average Monthly	Maximum Daily
Copper	µg/L	70	120
Selenium	µg/L	43	60
Zinc	µg/L	240	560
Cyanide	µg/L	21	42
Dioxin-TEQ <sup>[2]</sup>	µg/L	1.4 x 10 <sup>-8</sup>	2.8 x 10 <sup>-8</sup>
Ammonia (N)	mg/L	5.7	20

<sup>[1]</sup> a. Limitations apply to the average concentration of all samples collected during the averaging period (daily = 24-hour period; monthly = calendar month).

b. All metals limitations are expressed as total recoverable metal.

<sup>[2]</sup> Final effluent limitations for dioxin-TEQ shall become effective in accordance with the compliance schedule established by section VI.C.4.f of this Order.

**Table 8. Minimum Levels for Pollutants with Effluent Limitations**

Parameter	Minimum Level	Units
Copper	0.5	µg/L
Chromium (Total)	0.5	µg/L
Chromium(VI)	5	µg/L
Selenium	1	µg/L

Parameter	Minimum Level	Units
Zinc	1	µg/L
Cyanide	5	µg/L
Dioxin-TEQ	½ the USEPA specified MLs for Method 1613	µg/L
Ammonia	0.2	mg/L

### 3. Interim Effluent Limitation for Dioxin-TEQ

Until final effluent limitations for dioxin-TEQ become effective in accordance with the compliance schedule established by provision VI.C.4.f of this Order, the Discharger shall maintain compliance with the following interim limitation at Discharge Point 001, with compliance measured at Monitoring Location EFF-001 as described in the attached MRP.

**Table 9. Interim Effluent Limitations**

Parameter	Units	Effluent Limitations <sup>[1]</sup>	
		Average Monthly	Maximum Daily
Dioxin-TEQ	µg/L	1.4 x 10 <sup>-7</sup>	---

<sup>[1]</sup> The interim limit for dioxin-TEQ shall remain in effect until January 1, 2013.

### 4. Mass Emission Limitation for Selenium

Until implementation of a TMDL is in effect for selenium, the Discharger shall not increase mass loading of selenium to Suisun Bay through Discharge Point 001 by complying with the following mass emission limitation.

**Table 10. Selenium Mass Emission Limitation**

Pollutant	Units	Effluent Limitation
Selenium	kg/month	9.6

### 5. Acute Toxicity:

- a. Representative samples of the effluent at Monitoring Location EFF-001 shall meet the following limits for acute toxicity: Bioassays shall be conducted in compliance with section V.A of the Monitoring and Reporting Program (MRP, Attachment E).

The survival of organisms in undiluted effluent shall be

- (1) an eleven (11) sample median value of not less than 90 percent survival, and
- (2) an eleven (11) sample 90 percentile value of not less than 70 percent survival.

- b. These acute toxicity limitations are further defined as follows:

**11 sample median:** A bioassay test showing survival of less than 90 percent represents a violation of this effluent limit, if five or more of the past ten or less bioassay tests show less than 90 percent survival.

**90th percentile:** A bioassay test showing survival of less than 70 percent represents a violation of this effluent limit, if one or more of the past ten or less bioassay tests show less than 70 percent survival.

- c. Bioassays shall be performed using the most up-to-date USEPA protocol and the most sensitive species as specified in writing by the Executive Officer based on the most recent screening test results. Bioassays shall be conducted in compliance with “Methods for Measuring the Acute Toxicity of Effluents and Receiving Water to Freshwater and Marine Organisms,” currently 5th Edition (EPA-821-R-02-012), with exceptions granted to the Discharger by the Executive Officer and the Environmental Laboratory Accreditation Program (ELAP) upon the Discharger’s request with justification.
- d. If the Discharger can demonstrate to the satisfaction of the Executive Officer that toxicity exceeding the levels cited above is caused by ammonia and that the ammonia in the discharge complies with the ammonia effluent limitations, then such toxicity does not constitute a violation of this effluent limitation.

## 6. Chronic Toxicity

- a. Representative samples of the effluent at Monitoring Location EFF-001 shall meet the following limits for chronic toxicity. Bioassays shall be conducted in compliance with MRP section V.B (Attachment E).

The survival of bioassay test organisms in the discharge at Discharge Point 001 shall be:

- (1) An eleven sample median value equal to or less than 10 TUc, and
- (2) An eleven sample 90-percentile value equal to or less than 20 TUc.

- b. These chronic toxicity limits are defined as follows:

- (1) A test sample showing chronic toxicity greater than 10 TUc represents consistent toxicity and a violation of this limitation if five or more of the past ten or fewer tests show toxicity greater than 10 TUc.
- (2) A TUc equals 100/NOEL. The NOEL is the no observable effect level, determined from IC<sub>25</sub>, EC<sub>25</sub>, or NOEC values. These terms and their usage in determining compliance with the limitations are defined in Attachment B of this Order. The NOEL shall be based on a critical life stage test using the most sensitive test species as specified by the Executive Officer. The Executive Officer may specify two compliance species if test data indicate that there is alternating sensitivity between two species. If two compliance test species are specified, compliance shall be based in the maximum TUc value for the discharge sample based on a comparison of TUc values obtained through concurrent testing of the two species.
- (3) A test sample showing chronic toxicity greater than 20 TUc represents a violation of this limitation if one or more of the past ten or less samples shows toxicity greater than 20 TUc.

## c. Test Species and Methods

The Discharger shall conduct routine monitoring with the test species and protocols specified in MRP section V.B (Attachment E). The Discharger shall also perform Chronic Toxicity Screening Phase monitoring as described in Appendix E-1 of the MRP. Chronic Toxicity Monitoring Screening Phase Requirements, Critical Life Stage Toxicity Tests and definitions of terms used in the chronic toxicity monitoring are identified in Appendices E-1 and E-2 of the MRP.

**B. Storm Water Effluent Limitations - Discharge Points 002 – 011 and 016 - 017**

- Storm water discharged at Discharge Points 002 – 011 and 016 – 017 shall not exceed the effluent limitations in Table 11, below.

**Table 11. Effluent Limitations for Storm Water Outfalls**

Parameter	Units	Effluent Limitations	
		Average Monthly	Maximum Daily
TOC	mg/L	----	110
Oil & Grease	mg/L	----	15
pH	s.u.	6.5 – 8.5 at all times	
Visible Oil	---	None observed	
Visible Color	---	None observed	

- If there is an exceedance of either limitation for TOC or Oil and Grease expressed in Table 11, above, the effluent limitations in Table 12, below, shall become effective for the discharge point where the exceedance occurred and remain in effect as long as this Order remains in effect.

**Table 12. Supplemental Effluent Limitations for Storm Water Outfalls**

Pollutant	Units	Daily Maximum	30 Day Average
BOD <sub>5</sub>	mg/L	48	26
TSS	mg/L	33	21
COD	mg/L	360	180
Oil and Grease	mg/L	15	8.0
Phenolic Compounds	mg/L	0.35	0.17
Total Chromium	mg/L	0.60	0.21
Hexavalent Chromium	mg/L	0.062	0.028

**C. Land Discharge Specifications**

Not Applicable.

**D. Reclamation Specifications**

Not Applicable.





2. **Regional Standard Provisions.** The Discharger shall comply with all applicable items of the Regional Standard Provisions and Monitoring and Reporting Requirements included in Attachment G of this Order.

## **B. Monitoring and Reporting Program (MRP) Requirements**

The Discharger shall comply with the MRP, and future revisions thereto, in Attachment E. The Discharger shall also comply with applicable sampling and reporting requirements in the standard provisions listed in VI.A, above.

## **C. Special Provisions**

### **1. Reopener Provisions**

The Regional Water Board may modify or reopen this Order prior to its expiration date in any of the following circumstances as allowed by law:

- a. If present or future investigations demonstrate that the discharge governed by this Order will have, or will cease to have, a reasonable potential to cause or contribute to adverse impacts on water quality or beneficial uses of the receiving waters.
- b. If new or revised WQOs or TMDLs come into effect for the San Francisco Bay estuary and contiguous water bodies (whether statewide, regional, or site-specific). In such cases, effluent limitations in this Order will be modified as necessary to be consistent with updated WQOs and wasteload allocations in TMDLs. Adoption of effluent limitations in this Order is not intended to restrict in any way future modifications based on legally adopted WQOs or TMDLs, or as otherwise permitted under federal regulations governing NPDES permit modifications.
- c. If translator or other water quality studies provide a basis for determining that a permit condition should be modified.
- d. If an administrative or judicial decision on a separate NPDES permit or WDR that addresses requirements similar to this discharge provides a basis for permit modification.
- e. Or as otherwise authorized by law.

The Discharger may request a permit modification based on the above. The Discharger shall include in any such request an antidegradation and anti-backsliding analysis.

### **2. Special Studies and Additional Monitoring**

#### **a. Effluent Characterization Study**

The Discharger shall continue to monitor and evaluate the discharge from Discharge Point 001 (measured at EFF-001) according to the sampling frequency specified in the attached MRP (Attachment E). Compliance with this requirement shall be achieved in accordance with the specifications stated in the Regional Standard Provisions (Attachment G).

The Discharger shall evaluate on an annual basis if concentrations of any constituent increase over past performance. The Discharger shall investigate the cause of any increase. The investigation may include, but need not be limited to, an increase in the effluent monitoring frequency, monitoring of internal process streams, and monitoring of influent sources. This may be satisfied through identification of these constituents as “Pollutants of Concern” in the Discharger’s Pollutant Minimization Program described in Provision VI.C.3.b, below. The Discharger shall provide a summary of the annual evaluation of data and source investigation activities in the annual self-monitoring report.

The Discharger shall submit a final report that presents all the data to the Regional Water Board no later than 180 days prior to this Order expiration date. This final report shall be submitted with the application for permit reissuance.

**b. Ambient Background Receiving Water Study**

The Discharger shall collect, or participate in collecting, ambient background receiving water priority pollutant monitoring data necessary to perform reasonable potential analyses and to calculate effluent limitations. The data on the conventional water quality parameters (pH, salinity, and hardness) shall also be sufficient to characterize these parameters in the receiving waters at a point after the discharge has mixed with the receiving waters. This provision may be met through monitoring through the Collaborative Bay Area Clean Water Agencies (BACWA) Study or a similar ambient monitoring program for San Francisco Bay. This Order may be reopened, as appropriate, to incorporate effluent limits or other requirements based on these data.

The Discharger shall submit a final report that presents all the data to the Regional Water Board 180 days prior to this Order’s expiration date. This final report shall be submitted with the application for permit reissuance.

**c. Optional Mass Offset**

If the Discharger can demonstrate that further net reductions of the total mass loadings of 303(d)-listed pollutants to the receiving water cannot be achieved through economically feasible measures such as aggressive source control, wastewater reuse, and treatment plant optimization, but only through a mass offset program, the Discharger may submit to the Regional Water Board for approval a mass offset plan to reduce 303(d)-listed pollutants to the same watershed or drainage basin. The Regional Water Board may modify this Order to allow an approved mass offset program.

**d. Effluent and Receiving Water Selenium Characterization Study**

The Discharger shall comply with the following tasks and schedule to characterize (1) the concentrations and speciation of selenium in effluent and receiving water, (2) the variability of selenium in the discharge, (3) the potential for uptake and conversion of selenium to more bioavailable forms, (4) mixing and dilution in the receiving waters, and (5) the ability to comply with any more-stringent selenium criteria that may become effective in the foreseeable future. At its option, the Discharger may complete, or cause to be completed, all or some of the required tasks collaboratively with other dischargers.

**Table 13. Receiving Waters and Effluent Selenium Characterization Study  
Tasks and Schedule**

Tasks	Compliance Date
<p>(1) Submit a study plan for a minimum two-year study that includes the following elements:</p> <ul style="list-style-type: none"> <li>(a) effluent and receiving water sampling locations. Effluent sampling location may be E-001. Receiving water sampling locations shall be within a maximum 100-foot radius from of the outfall location to characterize near-field concentrations and speciation.</li> <li>(b) receiving water sampling along transects from the Pacific Ocean (Golden Gate) to the Sacramento (Rio Vista) and San Joaquin (USGS Station 757) Rivers, including sampling in the freshwater portions of the rivers at Vernalis ( San Joaquin River) and Freepport (Sacramento River),</li> <li>(c) sampling and analysis protocols (including means to evaluate seasonal conditions under low and high flows from the Sacramento / San Joaquin River Delta, selenium concentrations in the water column and suspended particles, detailed speciation and particulate selenium content in the effluent),</li> <li>(d) comparison of the proposed protocols and analytical methods to the previous sampling efforts,</li> <li>(e) sampling parameters (including, at a minimum, salinity, carbon, nitrogen and chlorophyll-a in receiving water, and dissolved and particulate concentrations of selenate, selenite, organic selenides and elemental selenium in both effluent and receiving water),</li> <li>(f) data interpretation models and other methods to be used (representing conservative, reasonable worst case conditions), and</li> <li>(g) implementation schedule.</li> </ul>	April 1, 2010
<p>(2) Begin implementation of the study plan developed for Task (1).</p>	July 15, 2010
<p>(3) Submit a status report for all the tasks required by this Provision that contain, at a minimum, monitoring data collected from the beginning of the study, summary of the results to date, and necessary updates to the study plan specified in this provision.</p>	Annually on February 1 <sup>st</sup> of 2011 and 2012, with the annual self-monitoring reports required by MPR (Attachment E).
<p>(4) Submit a final study report that includes the following elements:</p> <ul style="list-style-type: none"> <li>(a) sampling results, data interpretation, and conclusions, such as receiving water and mixing zone characterization, seasonal variability, etc.,</li> <li>(b) effluent characterization,</li> <li>(c) determination if there is reasonable potential for selenium in the discharge to violate the Basin Plan's narrative bioaccumulation objective through the use of pertinent models,</li> <li>(d) comparison of near-field selenium water column concentrations to applicable numeric objectives,</li> <li>(e) demonstration of spatial and temporal extent to which the objectives and other relevant guidelines, are being exceeded,</li> <li>(f) determination whether selenium levels impact foodweb and wildlife and/or contribute to bioaccumulation.</li> </ul>	August 15, 2012

**e. Additional Storm Water Monitoring**

Prior to release of storm water from the Upper Level Tank Farm, Intermediate Level Tank Farm, Lower Level Tank Farm, and Crude Oil Storage Area Tank Farm secondary containment areas through storm water outfalls 003, 006, 009 and 010, the storm water will be visually inspected for oil and color, and sampled and analyzed for TOC, TSS, and pH at minimum. Storm water not compliant with the limitations in Table 11, and Table 12 if applicable, or exceeding 100 mg/L TSS shall not be discharged to a storm water outfall. Instead, it shall be directed to the wastewater treatment plant, treated, and discharged through outfall 001 as treated wastewater.

**3. Best Management Practices and Pollution Minimization**

- a.** The Discharger shall continue to improve, in a manner acceptable to the Executive Officer, its Pollution Minimization Program (PMP) to promote minimization of pollutant loadings to the treatment plant and therefore to the receiving waters.
- b.** The Discharger shall submit an annual report, acceptable to the Executive Officer, no later than February 28 of each year. Annual reports shall cover January through December of the preceding year. Should the Discharger choose to submit earlier in the year, the report shall cover the preceding 12 months two months prior to the submittal date. As an example, a report submitted on June 30, would cover the preceding 12 month ending in April. Annual reports shall contain the following information:
  - i. A brief description of the treatment plant and treatment facilities.*
  - ii. A discussion of the current pollutants of concern.* Periodically, the Discharger shall determine which pollutants are currently a problem and which pollutants may be potential future problems. This discussion shall include the reasons why the pollutants were chosen.
  - iii. Identification of sources of pollutants of concern.* This discussion shall address how the Discharger identifies pollutant sources. The Discharger shall also identify sources or potential sources not directly within its ability or authority to control, such as pollutants in the potable water supply and air deposition.
  - iv. Identification and implementation of measures to reduce the sources of pollutants of concern.* This discussion shall identify and prioritize tasks to address the Discharger's pollutants of concern. The Discharger may implement tasks themselves or participate in group, regional, or national tasks that will address its pollutants of concern whenever it is efficient and appropriate to do so. A time line shall be included for the implementation of each task.
  - v. Outreach to employees.* The Discharger shall inform its employees regarding pollutants of concern, potential sources, and how they might be able to help reduce discharge of these pollutants. The Discharger may provide a forum for employees to provide input.

- vi. *Discussion of criteria used to measure the PMP's and tasks' effectiveness.* The Discharger shall establish criteria to evaluate the effectiveness of its PMP. This discussion shall address specific criteria used to measure the effectiveness of each of the tasks in sections VI.C.3.b.iv and v.
  - vii. *Documentation of efforts and progress.* This discussion shall detail all of the Discharger's activities in the PMP during the reporting year.
  - viii. *Evaluation of the PMP's and tasks' effectiveness.* The Discharger shall use the criteria established in section VI.C.3.b.vi above to evaluate the PMP's and tasks' effectiveness.
  - ix. *Identification of specific tasks and time schedules for future efforts.* Based on the evaluation, the Discharger shall describe how it will continue or change its PMP tasks to more effectively reduce the loading of pollutants to the treatment plant and therefore in its effluent.
- c.** The Discharger shall develop and conduct a PMP as further described below when there is evidence that a priority pollutant is present in the effluent above an effluent limitation and either:
- i. A sample result is reported as DNQ and the effluent limitation is less than the reporting limit (RL); or
  - ii. A sample result is reported as not detected (ND) and the effluent limitation is less than the MDL, using SIP definitions.
- d.** If triggered by the reasons in c., above, the Discharger's PMP shall include, but not be limited to, the following actions and submittals acceptable to the Regional Water Board:
- i. An annual review and semi-annual monitoring of potential sources of the reportable priority pollutants, which may include fish tissue monitoring and other bio-uptake sampling, or alternative measures approved by the Executive Officer when it is demonstrated that source monitoring is unlikely to produce useful analytical data;
  - ii. Quarterly monitoring for the reportable priority pollutants in the influent to the wastewater treatment system, or an alternative measure approved by the Executive Officer when it is demonstrated that influent monitoring is unlikely to produce useful analytical data;
  - iii. Submittal of a control strategy designed to proceed toward the goal of maintaining concentrations of the reportable priority pollutants in the effluent at or below the effluent limitation;
  - iv. Implementation of appropriate cost-effective control measures for the reportable priority pollutants, consistent with the control strategy; and
  - v. The annual report required by section VI.C.3.b above shall specifically address the following items:

- (a) All PMP monitoring results for the previous year;
- (b) A list of potential sources of the reportable priority pollutants;
- (c) A summary of all actions undertaken pursuant to the control strategy; and
- (d) A description of actions to be taken in the following year.

#### 4. Other Special Provisions

##### a. Cyanide Action Plan

The Discharger shall implement monitoring and surveillance, pretreatment, source control, and pollution prevention for cyanide in accordance with the following tasks and time schedule.

**Table 14. Cyanide Action Plan**

<b>Task</b>	<b>Compliance Date</b>
<b>1. Review Potential Cyanide Contributors</b> The Discharger shall submit an inventory of potential sources of cyanide to Discharge 001.	April 1, 2010
<b>2. Implement Cyanide Control Program</b> The Discharger shall submit a plan for and begin implementation of a program to minimize cyanide discharges. The plan shall include the following elements at minimum: <ul style="list-style-type: none"> <li>a. Inspect each potential contributor to assess the need to include that contributing source in the control program.</li> <li>b. Prepare an emergency monitoring and response plan to be implemented if a significant cyanide discharge occurs.</li> <li>c. If ambient monitoring shows cyanide concentrations of 1.0 µg/L or higher in the main body of San Francisco Bay, undertake actions to identify and abate cyanide sources responsible for the elevated ambient concentrations.</li> </ul>	July 1, 2010
<b>3. Report Status of Cyanide Control Program</b> Submit a report to the Regional Water Board documenting implementation of the cyanide control program.	Annually with annual PMP reports due February 28.

##### b. Copper Action Plan

The Discharger shall implement pretreatment, source control, and pollution prevention for copper in accordance with the following tasks and time schedule.

**Table 15. Copper Action Plan**

<b>Task</b>	<b>Compliance Date</b>
<b>1. Review Potential Copper Sources</b> The Discharger shall submit an inventory of potential copper sources to the discharge from Discharge Point 001.	April 1, 2010
<b>2. Implement Copper Control Program</b> The Discharger shall submit a plan for and begin implementation of a program to reduce copper discharges identified in Task 1.	July 1, 2010
<b>3. Implement Additional Measures</b> If the three-year rolling mean dissolved copper concentration of the receiving water exceeds 2.8 µg/L, the Discharger shall evaluate the effluent copper concentration trend, and if it is increasing, develop and implement additional measures to control copper discharges.	Within 90 days of exceedance
<b>4. Report Status of Copper Control Program</b> The Discharger shall submit a report to the Regional Water Board documenting implementation of the copper control program.	Annually with annual PMP reports due February 28

**c. Production Increase and Antidegradation Report**

The effluent limits in Table 6b shall replace those in Table 6a only after the Discharger submits an Antidegradation Report that demonstrates to the satisfaction of the Executive Officer that the increased throughput, and corresponding increased discharge rate and higher effluent limits, will not degrade receiving water quality, and is consistent with antidegradation policies, and with State Water Board Resolution No. 68-16 (*Statement of Policy with Respect to Maintaining High Quality of Waters in California*).

The Antidegradation Report shall include the following at minimum:

- A description of the proposed discharge;
- An analysis of the increased pollutant loads (in terms of mass and concentration) from the proposed discharge;
- An analysis of the existing quality of the receiving waters (Suisun Bay and Carquinez Strait) and a comparison to existing water quality standards;
- An analysis of the proposed increase in pollutant loading, and a comparison to other sources of pollutant loading to Suisun Bay and Carquinez Strait;
- Water quality modeling to assess the impact of pollutant loading resulting from the proposed increased discharge and from any other sources identified;
- An assessment of the impact of projected water quality changes with respect to existing water quality; and
- Proposed mitigation measures, such as increased treatment or expanded treatment facilities, needed to protect existing receiving water quality and beneficial uses

The Discharger shall also provide documentation to the Executive Officer when throughput increases to 165,000 bbls/d. Only following written notice from the Executive Officer shall the effluent limitations in Table 6b based on a throughput of 165,000 bbls/d become effective. The Executive Officer shall provide such notice if the documentation submitted demonstrates that no water quality degradation would occur.



**d. Storm Water Pollution Prevention Plan and Annual Report**

The Discharger shall update and submit an updated Storm Water Pollution Prevention Plan (SWPPP) acceptable to the Executive Officer by October 1 of each year. If the Discharger determines that it does not need to update its SWPPP, it shall submit a letter to the Executive Officer indicating that no revisions are necessary and stating the last year it updated its SWPPP. The Discharger shall implement the SWPPP. The SWPPP shall comply with the requirements in the Federal Standard Provisions (Attachment D).

The Discharger shall submit an annual storm water report by July 1 of each year covering data for the previous wet weather season for the identified storm water discharge points. The annual storm water report shall, at a minimum, include:

- (a) a tabulated summary of all sampling results and a summary of visual observations taken during inspections;
- (b) a comprehensive discussion of the compliance record and any corrective actions taken or planned to ensure compliance with WDRs; and
- (c) a comprehensive discussion of source identification and control programs for constituents that do not have effluent limitations (e.g., total suspended solids).

**e. Storm Water TSS Report and Best Management Practices**

The discharger shall document the potential causes of its historically elevated TSS values in its storm water discharges (above the benchmark value of 100 mg/L contained in USEPA's NPDES Stormwater Multi-Sector General Permit for Industrial Activities, Federal Register Volume 65, Number 210, October 30, 2000), and propose revised Best Management Practices and an implementation schedule in a separate report submitted to the Executive Officer by March 1, 2010. The Best Management Practices shall include measures to reduce erosion and control sediments, such as placement of riprap, gravel, rice wattle, or other physical controls. The Discharger shall report on its progress in implementing the revised Best Management Practices and in reducing storm water TSS levels below the benchmark value, or below the limits in Table 12 if they apply, in each Storm Water Annual Report.

**f. Dioxin-TEQ Compliance Schedule**

The following table outlines required actions and deadlines leading to compliance with the final effluent limitations for dioxin-TEQ.

**Table 16. Dioxin-TEQ Compliance Schedule**

Task	Deadline
a. Investigate sample collection, sample handling, and analytical laboratory quality assurance and quality control practices to ensure that analytical results for dioxin-TEQ are accurately determined and reported. Submit a report by the deadline describing the results of the investigation and any changes in quality assurance and quality control practices implemented.	April 1, 2010
b. If discharge data from the previous two years show discharge is	August 1, 2010

<b>Task</b>	<b>Deadline</b>
out of compliance (as defined in SIP section 2.4.5) with the permit effluent limits, submit a plan to identify all dioxin-TEQ sources to the discharge, and complete tasks c, d, and e.	
c. Implement the plan developed in action “b” within 30 days of the deadline for action “b,” and submit by the deadline for this action a report that contains an inventory of the pollutant sources.	December 1, 2010
d. Submit a report documenting development and initial implementation of a program to reduce and prevent the pollutants of concern in the discharge. The program shall consist, at a minimum, of the following elements: <ul style="list-style-type: none"> <li>i. Maintain a list of sources of pollutants of concern.</li> <li>ii. Investigate each source to assess the need to include it in the program.</li> <li>iii. Identify and implement targeted actions to reduce or eliminate</li> <li>iv. Develop and distribute, as appropriate, educational materials regarding the need to prevent sources to the sewer system.</li> </ul>	February 1, 2011
e. Continue to implement the program described in action “d” and submit annual status reports that evaluate its effectiveness and summarize planned changes. Report whether the program has successfully brought the discharge into compliance with the effluent limits in this Order. If not, identify and implement additional measures to further reduce discharges.	Annually each February 28 in PMP report required by Provision VI.C.3
f. Comply with the final limits in Table 7 as applicable:	January 1, 2013
g. Implement the measures required in action “e” within 45 days of the deadline for action “e” and submit annual status reports.	Annually each February 1 in Annual Self-Monitoring Report required by MRP (Attachment E)
i. Submit documentation confirming complete plan implementation and comply with final limits for dioxin-TEQ in Table 7.	January 1, 2013

## ATTACHMENT A – DEFINITIONS

**Arithmetic Mean ( $\mu$ )**, also called the average, is the sum of measured values divided by the number of samples. For ambient water concentrations, the arithmetic mean is calculated as follows:

Arithmetic mean =  $\mu = \Sigma x / n$  where:  $\Sigma x$  is the sum of the measured ambient water concentrations, and  $n$  is the number of samples.

**Average Monthly Effluent Limitation (AMEL)**: the highest allowable average of daily discharges over a calendar month, calculated as the sum of all daily discharges measured during a calendar month divided by the number of daily discharges measured during that month.

**Average Weekly Effluent Limitation (AWEL)**: the highest allowable average of daily discharges over a calendar week (Sunday through Saturday), calculated as the sum of all daily discharges measured during a calendar week divided by the number of daily discharges measured during that week.

**Bioaccumulative** pollutants are those substances taken up by an organism from its surrounding medium through gill membranes, epithelial tissue, or from food and subsequently concentrated and retained in the body of the organism.

**Carcinogenic** pollutants are substances that are known to cause cancer in living organisms.

**Coefficient of Variation (CV)** is a measure of the data variability and is calculated as the estimated standard deviation divided by the arithmetic mean of the observed values.

**Daily Discharge**: Daily Discharge is defined as either: (1) the total mass of the constituent discharged over the calendar day (12:00 am through 11:59 pm) or any 24-hour period that reasonably represents a calendar day for purposes of sampling (as specified in this Order), for a constituent with limitations expressed in units of mass or; (2) the unweighted arithmetic mean measurement of the constituent over the day for a constituent with limitations expressed in other units of measurement (e.g., concentration).

The daily discharge may be determined by the analytical results of a composite sample taken over the course of one day (a calendar day or other 24-hour period defined as a day) or by the arithmetic mean of analytical results from one or more grab samples taken over the course of the day.

For composite sampling, if 1 day is defined as a 24-hour period other than a calendar day, the analytical result for the 24-hour period will be considered as the result for the calendar day in which the 24-hour period ends.

**Detected, but Not Quantified (DNQ)** are those sample results less than the RL, but greater than or equal to the laboratory's MDL.

**Dilution Credit** is the amount of dilution granted to a discharge in the calculation of a water quality-based effluent limitation, based on the allowance of a specified mixing zone. It is calculated from the dilution ratio or determined through conducting a mixing zone study or modeling of the discharge and receiving water.

**Effluent Concentration Allowance (ECA)** is a value derived from the water quality criterion/objective, dilution credit, and ambient background concentration that is used, in conjunction with the coefficient of

variation for the effluent monitoring data, to calculate a long-term average (LTA) discharge concentration. The ECA has the same meaning as wasteload allocation (WLA) as used in USEPA guidance (Technical Support Document For Water Quality-based Toxics Control, March 1991, second printing, EPA/505/2-90-001).

**Enclosed Bays** means indentations along the coast that enclose an area of oceanic water within distinct headlands or harbor works. Enclosed bays include all bays where the narrowest distance between the headlands or outermost harbor works is less than 75 percent of the greatest dimension of the enclosed portion of the bay. Enclosed bays include, but are not limited to, Humboldt Bay, Bodega Harbor, Tomales Bay, Drake's Estero, San Francisco Bay, Morro Bay, Los Angeles-Long Beach Harbor, Upper and Lower Newport Bay, Mission Bay, and San Diego Bay. Enclosed bays do not include inland surface waters or ocean waters.

**Estimated Chemical Concentration** is the estimated chemical concentration that results from the confirmed detection of the substance by the analytical method below the ML value.

**Estuaries** means waters, including coastal lagoons, located at the mouths of streams that serve as areas of mixing for fresh and ocean waters. Coastal lagoons and mouths of streams that are temporarily separated from the ocean by sandbars shall be considered estuaries. Estuarine waters shall be considered to extend from a bay or the open ocean to a point upstream where there is no significant mixing of fresh water and seawater. Estuarine waters include, but are not limited to, the Sacramento-San Joaquin Delta, as defined in California Water Code section 12220, Suisun Bay, Carquinez Strait downstream to the Carquinez Bridge, and appropriate areas of the Smith, Mad, Eel, Noyo, Russian, Klamath, San Diego, and Otay rivers. Estuaries do not include inland surface waters or ocean waters.

**Inland Surface Waters** are all surface waters of the State that do not include the ocean, enclosed bays, or estuaries.

**Instantaneous Maximum Effluent Limitation:** the highest allowable value for any single grab sample or aliquot (i.e., each grab sample or aliquot is independently compared to the instantaneous maximum limitation).

**Instantaneous Minimum Effluent Limitation:** the lowest allowable value for any single grab sample or aliquot (i.e., each grab sample or aliquot is independently compared to the instantaneous minimum limitation).

**Maximum Daily Effluent Limitation (MDEL)** means the highest allowable daily discharge of a pollutant, over a calendar day (or 24-hour period). For pollutants with limitations expressed in units of mass, the daily discharge is calculated as the total mass of the pollutant discharged over the day. For pollutants with limitations expressed in other units of measurement, the daily discharge is calculated as the arithmetic mean measurement of the pollutant over the day.

**Median** is the middle measurement in a set of data. The median of a set of data is found by first arranging the measurements in order of magnitude (either increasing or decreasing order). If the number of measurements ( $n$ ) is odd, then the median =  $X_{(n+1)/2}$ . If  $n$  is even, then the median =  $(X_{n/2} + X_{(n/2)+1})/2$  (i.e., the midpoint between the  $n/2$  and  $n/2+1$ ).

**Method Detection Limit (MDL)** is the minimum concentration of a substance that can be measured and reported with 99 percent confidence that the analyte concentration is greater than zero, as defined in title 40 of the Code of Federal Regulations, Part 136, Attachment B, revised as of July 3, 1999.

**Minimum Level (ML)** is the concentration at which the entire analytical system must give a recognizable signal and acceptable calibration point. The ML is the concentration in a sample that is equivalent to the concentration of the lowest calibration standard analyzed by a specific analytical procedure, assuming that all the method specified sample weights, volumes, and processing steps have been followed.

**Mixing Zone** is a limited volume of receiving water that is allocated for mixing with a wastewater discharge where water quality criteria can be exceeded without causing adverse effects to the overall water body.

**Not Detected (ND)** are those sample results less than the laboratory's MDL.

**Ocean Waters** are the territorial marine waters of the State as defined by California law to the extent these waters are outside of enclosed bays, estuaries, and coastal lagoons. Discharges to ocean waters are regulated in accordance with the State Water Board's California Ocean Plan.

**Persistent** pollutants are substances for which degradation or decomposition in the environment is nonexistent or very slow.

**Pollutant Minimization Program (PMP)** means waste minimization and pollution prevention actions that include, but are not limited to, product substitution, waste stream recycling, alternative waste management methods, and education of the public and businesses. The goal of the PMP shall be to reduce all potential sources of a priority pollutant(s) through pollutant minimization (control) strategies, including pollution prevention measures as appropriate, to maintain the effluent concentration at or below the water quality-based effluent limitation. Pollution prevention measures may be particularly appropriate for persistent bioaccumulative priority pollutants where there is evidence that beneficial uses are being impacted. The Regional Water Board may consider cost effectiveness when establishing the requirements of a PMP. The completion and implementation of a Pollution Prevention Plan, if required pursuant to California Water Code section 13263.3(d), shall be considered to fulfill the PMP requirements.

**Pollution Prevention** means any action that causes a net reduction in the use or generation of a hazardous substance or other pollutant that is discharged into water and includes, but is not limited to, input change, operational improvement, production process change, and product reformulation (as defined in California Water Code section 13263.3). Pollution prevention does not include actions that merely shift a pollutant in wastewater from one environmental medium to another environmental medium, unless clear environmental benefits of such an approach are identified to the satisfaction of the State or Regional Water Board.

**Reporting Level (RL)** is the ML (and its associated analytical method) chosen by the Discharger for reporting and compliance determination from the MLs included in this Order. The MLs included in this Order correspond to approved analytical methods for reporting a sample result that are selected by the Regional Water Board either from SIP Appendix 4 in accordance with SIP section 2.4.2 or established in accordance with SIP section 2.4.3. The ML is based on the proper application of method-based analytical procedures for sample preparation and the absence of any matrix interferences. Other factors

may be applied to the ML depending on the specific sample preparation steps employed. For example, the treatment typically applied in cases where there are matrix-effects is to dilute the sample or sample aliquot by a factor of ten. In such cases, this additional factor must be applied to the ML in the computation of the RL.

**Satellite Collection System** is the portion, if any, of a sanitary sewer system owned or operated by a different public agency than the agency that owns and operates the wastewater treatment facility that a sanitary sewer system is tributary to.

**Source of Drinking Water** is any water designated as municipal or domestic supply (MUN) in a Regional Water Board Basin Plan.

**Standard Deviation ( $\sigma$ )** is a measure of variability that is calculated as follows:

$$\sigma = (\sum[(x - \mu)^2]/(n - 1))^{0.5}$$

where:

x is the observed value;

$\mu$  is the arithmetic mean of the observed values; and

n is the number of samples.

**Toxicity Reduction Evaluation (TRE)** is a study conducted in a step-wise process designed to identify the causative agents of effluent or ambient toxicity, isolate the sources of toxicity, evaluate the effectiveness of toxicity control options, and then confirm the reduction in toxicity. The first steps of the TRE consist of the collection of data relevant to the toxicity, including additional toxicity testing, and an evaluation of facility operations and maintenance practices, and best management practices. A Toxicity Identification Evaluation (TIE) may be required as part of the TRE, if appropriate. (A TIE is a set of procedures to identify the specific chemical(s) responsible for toxicity. These procedures are performed in three phases (characterization, identification, and confirmation) using aquatic organism toxicity tests.)

**ATTACHMENT B – FACILITY MAP**

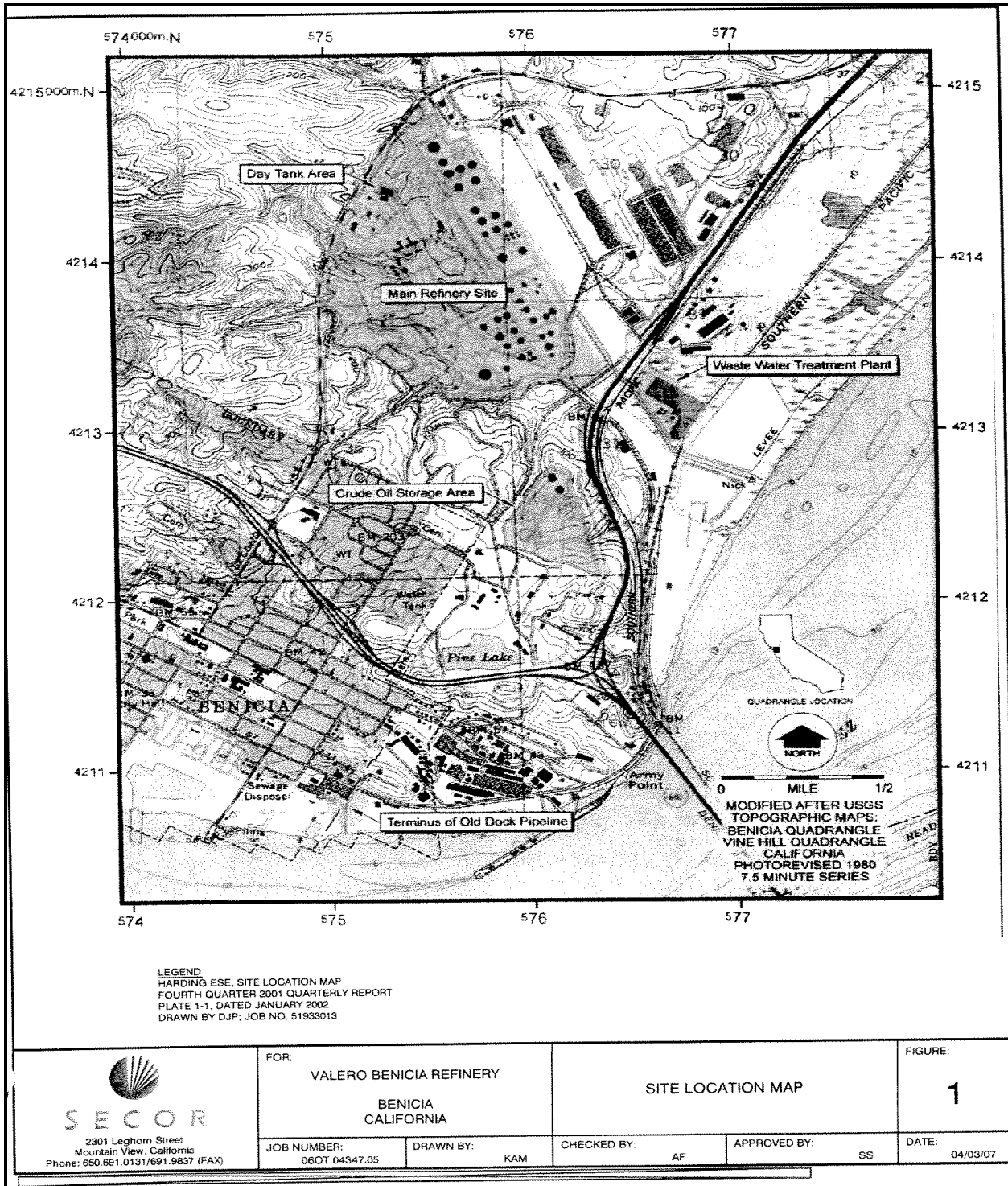

**ATTACHMENT C – PROCESS FLOW DIAGRAM**

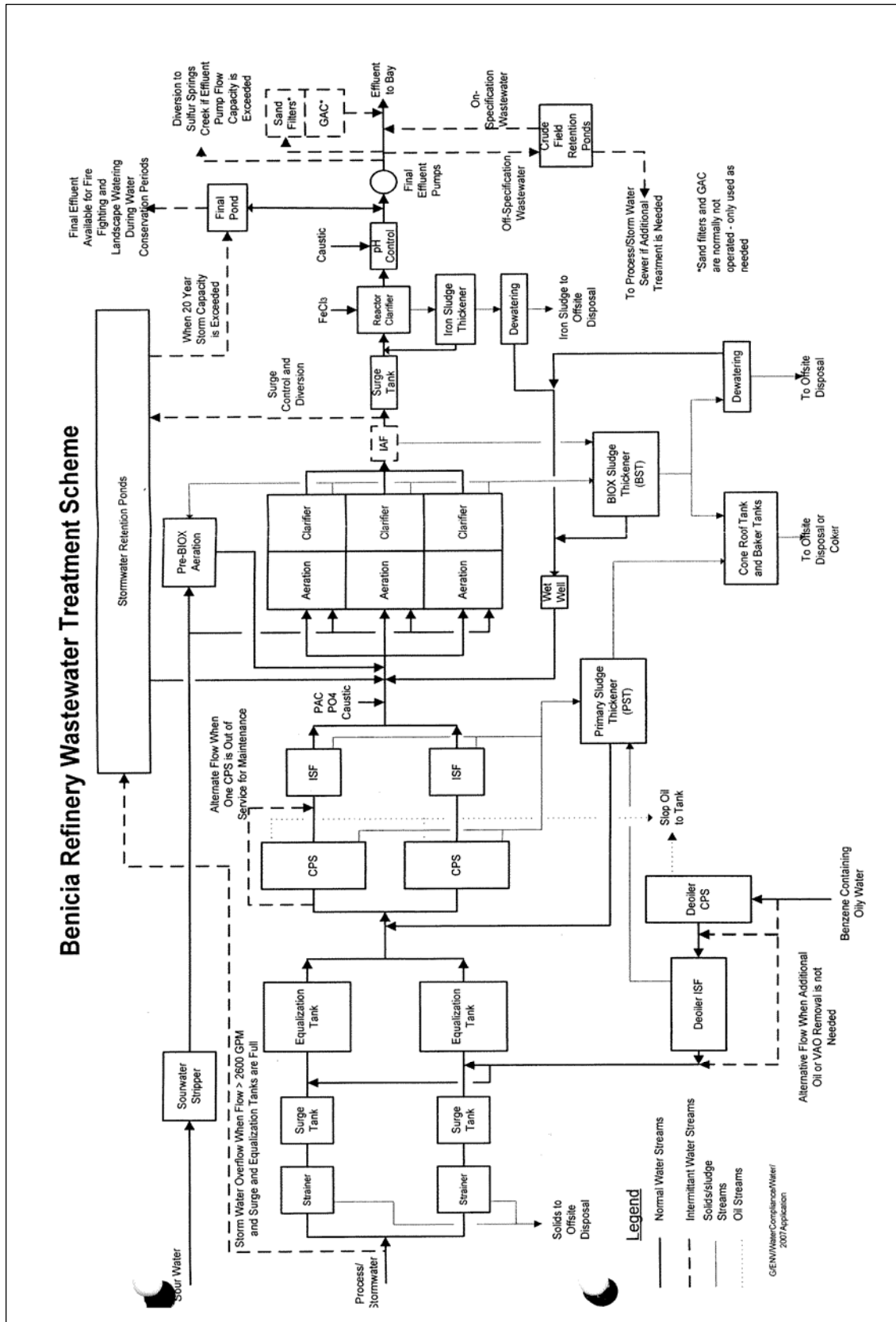



## **ATTACHMENT D –STANDARD PROVISIONS**

### **I. STANDARD PROVISIONS – PERMIT COMPLIANCE**

#### **A. Duty to Comply**

1. The Discharger must comply with all of the conditions of this Order. Any noncompliance constitutes a violation of the Clean Water Act (CWA) and the California Water Code and is grounds for enforcement action, for permit termination, revocation and reissuance, or modification; or denial of a permit renewal application. (40 C.F.R. § 122.41(a).)
2. The Discharger shall comply with effluent standards or prohibitions established under section 307(a) of the CWA for toxic pollutants and with standards for sewage sludge use or disposal established under section 405(d) of the CWA within the time provided in the regulations that establish these standards or prohibitions, even if this Order has not yet been modified to incorporate the requirement. (40 C.F.R. § 122.41(a)(1).)

#### **B. Need to Halt or Reduce Activity Not a Defense**

It shall not be a defense for a Discharger in an enforcement action that it would have been necessary to halt or reduce the permitted activity in order to maintain compliance with the conditions of this Order. (40 C.F.R. § 122.41(c).)

#### **C. Duty to Mitigate**

The Discharger shall take all reasonable steps to minimize or prevent any discharge or sludge use or disposal in violation of this Order that has a reasonable likelihood of adversely affecting human health or the environment. (40 C.F.R. § 122.41(d).)

#### **D. Proper Operation and Maintenance**

The Discharger shall at all times properly operate and maintain all facilities and systems of treatment and control (and related appurtenances) which are installed or used by the Discharger to achieve compliance with the conditions of this Order. Proper operation and maintenance also includes adequate laboratory controls and appropriate quality assurance procedures. This provision requires the operation of backup or auxiliary facilities or similar systems that are installed by a Discharger only when necessary to achieve compliance with the conditions of this Order (40 C.F.R. § 122.41(e)).

#### **E. Property Rights**

1. This Order does not convey any property rights of any sort or any exclusive privileges. (40 C.F.R. § 122.41(g).)
2. The issuance of this Order does not authorize any injury to persons or property or invasion of other private rights, or any infringement of State or local law or regulations. (40 C.F.R. § 122.5(c).)

## F. Inspection and Entry

The Discharger shall allow the Regional Water Board, State Water Board, United States Environmental Protection Agency (USEPA), or their authorized representatives (including an authorized contractor acting as their representative), upon the presentation of credentials and other documents, as may be required by law, to (40 C.F.R. § 122.41(i); Wat. Code, § 13383):

1. Enter upon the Discharger's premises where a regulated facility or activity is located or conducted, or where records are kept under the conditions of this Order (40 C.F.R. § 122.41(i)(1));
2. Have access to and copy, at reasonable times, any records that must be kept under the conditions of this Order (40 C.F.R. § 122.41(i)(2));
3. Inspect and photograph, at reasonable times, any facilities, equipment (including monitoring and control equipment), practices, or operations regulated or required under this Order (40 C.F.R. § 122.41(i)(3)); and
4. Sample or monitor, at reasonable times, for the purposes of assuring Order compliance or as otherwise authorized by the CWA or the Water Code, any substances or parameters at any location. (40 C.F.R. § 122.41(i)(4).)

## G. Bypass

1. Definitions
  - a. "Bypass" means the intentional diversion of waste streams from any portion of a treatment facility. (40 C.F.R. § 122.41(m)(1)(i).)
  - b. "Severe property damage" means substantial physical damage to property, damage to the treatment facilities, which causes them to become inoperable, or substantial and permanent loss of natural resources that can reasonably be expected to occur in the absence of a bypass. Severe property damage does not mean economic loss caused by delays in production. (40 C.F.R. § 122.41(m)(1)(ii).)
2. Bypass not exceeding limitations. The Discharger may allow any bypass to occur which does not cause exceedances of effluent limitations, but only if it is for essential maintenance to assure efficient operation. These bypasses are not subject to the provisions listed in Standard Provisions – Permit Compliance I.G.3, I.G.4, and I.G.5 below. (40 C.F.R. § 122.41(m)(2).)
3. Prohibition of bypass. Bypass is prohibited, and the Regional Water Board may take enforcement action against a Discharger for bypass, unless (40 C.F.R. § 122.41(m)(4)(i)):
  - a. Bypass was unavoidable to prevent loss of life, personal injury, or severe property damage (40 C.F.R. § 122.41(m)(4)(i)(A));
  - b. There were no feasible alternatives to the bypass, such as the use of auxiliary treatment facilities, retention of untreated wastes, or maintenance during normal periods of equipment downtime. This condition is not satisfied if adequate back-up equipment

- should have been installed in the exercise of reasonable engineering judgment to prevent a bypass that occurred during normal periods of equipment downtime or preventive maintenance (40 C.F.R. § 122.41(m)(4)(i)(B)); and
- c. The Discharger submitted notice to the Regional Water Board as required under Standard Provisions – Permit Compliance I.G.5 below. (40 C.F.R. § 122.41(m)(4)(i)(C).)
  4. The Regional Water Board may approve an anticipated bypass, after considering its adverse effects, if the Regional Water Board determines that it will meet the three conditions listed in Standard Provisions – Permit Compliance I.G.3 above. (40 C.F.R. § 122.41(m)(4)(ii).)
  5. Notice
    - a. Anticipated bypass. If the Discharger knows in advance of the need for a bypass, it shall submit a notice, if possible at least 10 days before the date of the bypass. (40 C.F.R. § 122.41(m)(3)(i).)
    - b. Unanticipated bypass. The Discharger shall submit notice of an unanticipated bypass as required in Standard Provisions - Reporting V.E below (24-hour notice). (40 C.F.R. § 122.41(m)(3)(ii).)

## H. Upset

Upset means an exceptional incident in which there is unintentional and temporary noncompliance with technology based permit effluent limitations because of factors beyond the reasonable control of the Discharger. An upset does not include noncompliance to the extent caused by operational error, improperly designed treatment facilities, inadequate treatment facilities, lack of preventive maintenance, or careless or improper operation. (40 C.F.R. § 122.41(n)(1).)

1. Effect of an upset. An upset constitutes an affirmative defense to an action brought for noncompliance with such technology based permit effluent limitations if the requirements of Standard Provisions – Permit Compliance I.H.2 below are met. No determination made during administrative review of claims that noncompliance was caused by upset, and before an action for noncompliance, is final administrative action subject to judicial review. (40 C.F.R. § 122.41(n)(2).)
2. Conditions necessary for a demonstration of upset. A Discharger who wishes to establish the affirmative defense of upset shall demonstrate, through properly signed, contemporaneous operating logs or other relevant evidence that (40 C.F.R. § 122.41(n)(3)):
  - a. An upset occurred and that the Discharger can identify the cause(s) of the upset (40 C.F.R. § 122.41(n)(3)(i));
  - b. The permitted facility was, at the time, being properly operated (40 C.F.R. § 122.41(n)(3)(ii));
  - c. The Discharger submitted notice of the upset as required in Standard Provisions – Reporting V.E.2.b below (24-hour notice) (40 C.F.R. § 122.41(n)(3)(iii)); and

- d. The Discharger complied with any remedial measures required under Standard Provisions – Permit Compliance I.C above. (40 C.F.R. § 122.41(n)(3)(iv).)
3. Burden of proof. In any enforcement proceeding, the Discharger seeking to establish the occurrence of an upset has the burden of proof. (40 C.F.R. § 122.41(n)(4).)

## **II. STANDARD PROVISIONS – PERMIT ACTION**

### **A. General**

This Order may be modified, revoked and reissued, or terminated for cause. The filing of a request by the Discharger for modification, revocation and reissuance, or termination, or a notification of planned changes or anticipated noncompliance does not stay any Order condition. (40 C.F.R. § 122.41(f).)

### **B. Duty to Reapply**

If the Discharger wishes to continue an activity regulated by this Order after the expiration date of this Order, the Discharger must apply for and obtain a new permit. (40 C.F.R. § 122.41(b).)

### **C. Transfers**

This Order is not transferable to any person except after notice to the Regional Water Board. The Regional Water Board may require modification or revocation and reissuance of this Order to change the name of the Discharger and incorporate such other requirements as may be necessary under the CWA and the Water Code. (40 C.F.R. § 122.41(l)(3); § 122.61.)

## **III. STANDARD PROVISIONS – MONITORING**

- A. Samples and measurements taken for the purpose of monitoring shall be representative of the monitored activity. (40 C.F.R. § 122.41(j)(1).)
- B. Monitoring results must be conducted according to test procedures under Part 136 or, in the case of sludge use or disposal, approved under Part 136 unless otherwise specified in Part 503 unless other test procedures have been specified in this Order. (40 C.F.R. § 122.41(j)(4); § 122.44(i)(1)(iv).)

## **IV. STANDARD PROVISIONS – RECORDS**

- A. Except for records of monitoring information required by this Order related to the Discharger's sewage sludge use and disposal activities, which shall be retained for a period of at least five years (or longer as required by Part 503), the Discharger shall retain records of all monitoring information, including all calibration and maintenance records and all original strip chart recordings for continuous monitoring instrumentation, copies of all reports required by this Order, and records of all data used to complete the application for this Order, for a period of at least three (3) years from the date of the sample, measurement, report or application. This period may be extended by request of the Regional Water Board Executive Officer at any time. (40 C.F.R. § 122.41(j)(2).)
- B. Records of monitoring information shall include:
  1. The date, exact place, and time of sampling or measurements (40 C.F.R. § 122.41(j)(3)(i));

2. The individual(s) who performed the sampling or measurements (40 C.F.R. § 122.41(j)(3)(ii));
  3. The date(s) analyses were performed (40 C.F.R. § 122.41(j)(3)(iii));
  4. The individual(s) who performed the analyses (40 C.F.R. § 122.41(j)(3)(iv));
  5. The analytical techniques or methods used (40 C.F.R. § 122.41(j)(3)(v)); and
  6. The results of such analyses. (40 C.F.R. § 122.41(j)(3)(vi).)
- C. Claims of confidentiality for the following information will be denied (40 C.F.R. § 122.7(b)):
1. The name and address of any permit applicant or Discharger (40 C.F.R. § 122.7(b)(1)); and
  2. Permit applications and attachments, permits and effluent data. (40 C.F.R. § 122.7(b)(2).)

## **V. STANDARD PROVISIONS – REPORTING**

### **A. Duty to Provide Information**

The Discharger shall furnish to the Regional Water Board, State Water Board, or USEPA within a reasonable time, any information which the Regional Water Board, State Water Board, or USEPA may request to determine whether cause exists for modifying, revoking and reissuing, or terminating this Order or to determine compliance with this Order. Upon request, the Discharger shall also furnish to the Regional Water Board, State Water Board, or USEPA copies of records required to be kept by this Order. (40 C.F.R. § 122.41(h); Wat. Code, § 13267.)

### **B. Signatory and Certification Requirements**

1. All applications, reports, or information submitted to the Regional Water Board, State Water Board, or USEPA shall be signed and certified in accordance with Standard Provisions – Reporting V.B.2, V.B.3, V.B.4, and V.B.5 below. (40 C.F.R. § 122.41(k))
2. All permit applications shall be signed by a responsible corporate officer. For purposes of this provision, a responsible corporate officer means: (i) A president, secretary, treasurer, or vice-president of the corporation in charge of a principal business function, or any other person who performs similar policy- or decision-making functions for the corporation, or (ii) the manager of one or more manufacturing, production, or operating facilities, provided, the manager is authorized to make management decisions which govern the operation of the regulated facility including having the explicit or implicit duty of making major capital investment recommendations, and initiating and directing other comprehensive measures to assure long term environmental compliance with environmental laws and regulations; the manager can ensure that the necessary systems are established or actions taken to gather complete and accurate information for permit application requirements; and where authority to sign documents has been assigned or delegated to the manager in accordance with corporate procedures. (40 C.F.R. § 122.22(a)(1))
3. All reports required by this Order and other information requested by the Regional Water Board, State Water Board, or USEPA shall be signed by a person described in Standard

Provisions – Reporting V.B.2 above, or by a duly authorized representative of that person. A person is a duly authorized representative only if:

- a. The authorization is made in writing by a person described in Standard Provisions – Reporting V.B.2 above (40 C.F.R. § 122.22(b)(1));
  - b. The authorization specifies either an individual or a position having responsibility for the overall operation of the regulated facility or activity such as the position of plant manager, operator of a well or a well field, superintendent, position of equivalent responsibility, or an individual or position having overall responsibility for environmental matters for the company. (A duly authorized representative may thus be either a named individual or any individual occupying a named position.) (40 C.F.R. § 122.22(b)(2)); and
  - c. The written authorization is submitted to the Regional Water Board and State Water Board. (40 C.F.R. § 122.22(b)(3).)
4. If an authorization under Standard Provisions – Reporting V.B.3 above is no longer accurate because a different individual or position has responsibility for the overall operation of the facility, a new authorization satisfying the requirements of Standard Provisions – Reporting V.B.3 above must be submitted to the Regional Water Board and State Water Board prior to or together with any reports, information, or applications, to be signed by an authorized representative. (40 C.F.R. § 122.22(c).)
5. Any person signing a document under Standard Provisions – Reporting V.B.2 or V.B.3 above shall make the following certification:

“I certify under penalty of law that this document and all attachments were prepared under my direction or supervision in accordance with a system designed to assure that qualified personnel properly gather and evaluate the information submitted. Based on my inquiry of the person or persons who manage the system or those persons directly responsible for gathering the information, the information submitted is, to the best of my knowledge and belief, true, accurate, and complete. I am aware that there are significant penalties for submitting false information, including the possibility of fine and imprisonment for knowing violations.” (40 C.F.R. § 122.22(d).)

### **C. Monitoring Reports**

1. Monitoring results shall be reported at the intervals specified in the Monitoring and Reporting Program (Attachment E) in this Order. (40 C.F.R. § 122.22(l)(4).)
2. Monitoring results must be reported on a Discharge Monitoring Report (DMR) form or forms provided or specified by the Regional Water Board or State Water Board for reporting results of monitoring of sludge use or disposal practices. (40 C.F.R. § 122.41(l)(4)(i).)
3. If the Discharger monitors any pollutant more frequently than required by this Order using test procedures approved under Part 136 or, in the case of sludge use or disposal, approved under Part 136 unless otherwise specified in Part 503, or as specified in this Order, the results of this monitoring shall be included in the calculation and reporting of the data submitted in

the DMR or sludge reporting form specified by the Regional Water Board. (40 C.F.R. § 122.41(l)(4)(ii).)

4. Calculations for all limitations, which require averaging of measurements, shall utilize an arithmetic mean unless otherwise specified in this Order. (40 C.F.R. § 122.41(l)(4)(iii).)

#### **D. Compliance Schedules**

Reports of compliance or noncompliance with, or any progress reports on, interim and final requirements in any compliance schedule of this Order, shall be submitted no later than 14 days following each schedule date. (40 C.F.R. § 122.41(l)(5).)

#### **E. Twenty-Four Hour Reporting**

1. The Discharger shall report any noncompliance that may endanger health or the environment. Any information shall be provided orally within 24 hours from the time the Discharger becomes aware of the circumstances. A written submission shall also be provided within five (5) days of the time the Discharger becomes aware of the circumstances. The written submission shall contain a description of the noncompliance and its cause; the period of noncompliance, including exact dates and times, and if the noncompliance has not been corrected, the anticipated time it is expected to continue; and steps taken or planned to reduce, eliminate, and prevent reoccurrence of the noncompliance. (40 C.F.R. § 122.41(l)(6)(i).)
2. The following shall be included as information that must be reported within 24 hours under this paragraph (40 C.F.R. § 122.41(l)(6)(ii)):
  - a. Any unanticipated bypass that exceeds any effluent limitation in this Order. (40 C.F.R. § 122.41(l)(6)(ii)(A).)
  - b. Any upset that exceeds any effluent limitation in this Order. (40 C.F.R. § 122.41(l)(6)(ii)(B).)
3. The Regional Water Board may waive the above-required written report under this provision on a case-by-case basis if an oral report has been received within 24 hours. (40 C.F.R. § 122.41(l)(6)(iii).)

#### **F. Planned Changes**

The Discharger shall give notice to the Regional Water Board as soon as possible of any planned physical alterations or additions to the permitted facility. Notice is required under this provision only when (40 C.F.R. § 122.41(l)(1)):

1. The alteration or addition to a permitted facility may meet one of the criteria for determining whether a facility is a new source in section 122.29(b) (40 C.F.R. § 122.41(l)(1)(i)); or
2. The alteration or addition could significantly change the nature or increase the quantity of pollutants discharged. This notification applies to pollutants that are not subject to effluent limitations in this Order. (40 C.F.R. § 122.41(l)(1)(ii).)

3. The alteration or addition results in a significant change in the Discharger's sludge use or disposal practices, and such alteration, addition, or change may justify the application of permit conditions that are different from or absent in the existing permit, including notification of additional use or disposal sites not reported during the permit application process or not reported pursuant to an approved land application plan. (40 C.F.R. § 122.41(l)(1)(iii).)

#### **G. Anticipated Noncompliance**

The Discharger shall give advance notice to the Regional Water Board or State Water Board of any planned changes in the permitted facility or activity that may result in noncompliance with General Order requirements. (40 C.F.R. § 122.41(l)(2).)

#### **H. Other Noncompliance**

The Discharger shall report all instances of noncompliance not reported under Standard Provisions – Reporting V.C, V.D, and V.E above at the time monitoring reports are submitted. The reports shall contain the information listed in Standard Provision – Reporting V.E above. (40 C.F.R. § 122.41(l)(7).)

#### **I. Other Information**

When the Discharger becomes aware that it failed to submit any relevant facts in a permit application, or submitted incorrect information in a permit application or in any report to the Regional Water Board, State Water Board, or USEPA, the Discharger shall promptly submit such facts or information. (40 C.F.R. § 122.41(l)(8).)

### **VI. STANDARD PROVISIONS – ENFORCEMENT**

- A. The Regional Water Board is authorized to enforce the terms of this Order under several provisions of the Water Code, including, but not limited to, sections 13385, 13386, and 13387.

### **VII. ADDITIONAL PROVISIONS – NOTIFICATION LEVELS**

#### **A. Non-Municipal Facilities**

Existing manufacturing, commercial, mining, and silvicultural Dischargers shall notify the Regional Water Board as soon as they know or have reason to believe (40 C.F.R. § 122.42(a)):

1. That any activity has occurred or will occur that would result in the discharge, on a routine or frequent basis, of any toxic pollutant that is not limited in this Order, if that discharge will exceed the highest of the following "notification levels" (40 C.F.R. § 122.42(a)(1)):
  - a. 100 micrograms per liter ( $\mu\text{g/L}$ ) (40 C.F.R. § 122.42(a)(1)(i));
  - b. 200  $\mu\text{g/L}$  for acrolein and acrylonitrile; 500  $\mu\text{g/L}$  for 2,4-dinitrophenol and 2-methyl-4,6-dinitrophenol; and 1 milligram per liter (mg/L) for antimony (40 C.F.R. § 122.42(a)(1)(ii));



- c.** Five (5) times the maximum concentration value reported for that pollutant in the Report of Waste Discharge (40 C.F.R. § 122.42(a)(1)(iii)); or
  - d.** The level established by the Regional Water Board in accordance with section 122.44(f). (40 C.F.R. § 122.42(a)(1)(iv).)
- 2.** That any activity has occurred or will occur that would result in the discharge, on a non-routine or infrequent basis, of any toxic pollutant that is not limited in this Order, if that discharge will exceed the highest of the following “notification levels” (40 C.F.R. § 122.42(a)(2)):
  - a.** 500 micrograms per liter ( $\mu\text{g/L}$ ) (40 C.F.R. § 122.42(a)(2)(i));
  - b.** 1 milligram per liter ( $\text{mg/L}$ ) for antimony (40 C.F.R. § 122.42(a)(2)(ii));
  - c.** Ten (10) times the maximum concentration value reported for that pollutant in the Report of Waste Discharge (40 C.F.R. § 122.42(a)(2)(iii)); or
  - d.** The level established by the Regional Water Board in accordance with section 122.44(f). (40 C.F.R. § 122.42(a)(2)(iv).)

**ATTACHMENT E – MONITORING AND REPORTING PROGRAM****Table of Contents**

I.	General Monitoring Provisions.....	E-2
II.	Monitoring Locations.....	E-3
III.	Influent Monitoring Requirements .....	E-4
IV.	Effluent Monitoring Requirements .....	E-4
	A. Treated Process Wastewater Monitoring .....	E-4
	B. Storm Water Monitoring .....	E-5
V.	Whole Effluent Toxicity Testing .....	E-6
VI.	Receiving water Monitoring Requirements .....	E-9
VII.	Legend for MRP Tables.....	E-9
VIII.	Reporting Requirments .....	E-10
	A. General Monitoring and Reporting Requirements .....	E-10
	B. Self Monitoring Reports (SMRs) .....	E-10
	C. Discharge Monitoring Reports (DMRs).....	E-12
	D. Other Reports .....	E-13

**Tables**

Table E-1.	Test Methods and Minimum Levels for Pollutants with Effluent Limits .....	E-2
Table E-2.	Monitoring Station Locations .....	E-3
Table E-3.	Treated Process Wastewater Monitoring .....	E-4
Table E-4.	Storm Water Monitoring.....	E-5
Table E-5.	Monitoring Periods and Reporting Schedule.....	E-10

**ATTACHMENT E – MONITORING AND REPORTING PROGRAM (MRP)**

40 CFR 122.48 requires that all NPDES permits specify monitoring and reporting requirements. California Water Code (CWC) sections 13267 and 13383 also authorize the Regional Water Board to require technical and monitoring reports. This MRP establishes monitoring and reporting requirements that implement the federal and California regulations.

**I. GENERAL MONITORING PROVISIONS**

- A.** The Discharger shall comply with this MRP as adopted by the Regional Water Board, and with all of the Regional Standard Provisions (Attachment G). The Executive Officer may amend the MRP and Regional Standard Provisions pursuant to 40 CFR 122.62, 122.63, and 124.5. If any discrepancies exist between the MRP and the Regional Standard Provisions, the MRP prevails.
- B.** Sampling is required during the entire year when discharging. All analyses shall be conducted using current USEPA methods, or methods that have been approved by the USEPA Regional Administrator pursuant to 40 CFR 136.4 and 40 CFR 136.5, or equivalent methods that are commercially and reasonably available and that provide quantification of sampling parameters and constituents sufficient to evaluate compliance with applicable effluent limits and to perform reasonable potential analyses. Equivalent methods must be more sensitive than those specified in 40 CFR 136, must be specified in the permit, and must be approved for use by the Executive Officer following consultation with the State Water Board's Quality Assurance Program.
- C.** Sampling and analysis of additional constituents is required pursuant to Table C of the Regional Standard Provisions (Attachment G).
- D.** For compliance and reasonable potential monitoring, analyses shall be conducted using the commercially available and reasonably achievable detection levels that are lower than applicable water quality objectives or criteria, or the effluent limitations, whichever is lower. The objective is to provide quantification of constituents sufficient to allow evaluation of observed concentrations with respect to the Minimum Levels (MLs) given below.

MLs are the concentrations at which the entire analytical system must give a recognizable signal and acceptable calibration point. The ML is the concentration in a sample that is equivalent to the concentration of the lowest calibration standard analyzed by a specific analytical procedure, assuming that all the method specified sample weights, volumes, and processing steps have been followed. All MLs are expressed as micrograms per liter ( $\mu\text{g/L}$ ).

Table E-1 lists the test methods the Discharger may use for compliance and reasonable potential monitoring for the pollutants with effluent limits.

**Table E-1. Test Methods and Minimum Levels for Pollutants with Effluent Limits**

CTR #	Constituent	Types of Analytical Methods <sup>[a]</sup>											
		Minimum Levels ( $\mu\text{g/L}$ )											
		GC	GCMS	LC	Color	FAA	GFAA	ICP	ICPMS	SPGFAA	HYDRIDE	CVAF	DCP
6	Copper						5		0.5	2			
	Chromium (Total)						2		0.5	1			
5b	Hexavalent chromium				10	5							
10	Selenium						5		2	5	1		

CTR #	Constituent	Types of Analytical Methods <sup>[a]</sup>												
		Minimum Levels (µg/L)												
		GC	GCMS	LC	Color	FAA	GFAA	ICP	ICPMS	SPGFAA	HYDRIDE	CVAF	DCP	
13	Zinc					20			1	10				
14	Cyanide				5									
	Dioxin-TEQ <sup>[B]</sup>	Use USEPA Method 1613												
	Ammonia (N)	0.2 mg/L (as N) using titration method												

<sup>[a]</sup> Analytical Methods / Laboratory techniques are defined as follows:

- Color = Colorimetric
- CVAF = Cold Vapor Atomic Fluorescence
- DCP = Direct Current Plasma
- FAA = Furnace Atomic Absorption
- GC = Gas Chromatography
- GCMS = Gas Chromatography Mass Spectroscopy
- GFAA = Graphite Furnace Atomic Absorption
- HYDRIDE= Hydride Generation Atomic Absorption
- ICP = Inductively Coupled Plasma
- ICPMS = Inductively Coupled Plasma/Mass Spectrometry
- LC = Liquid Chromatography
- SPGFAA = Stabilized Platform Graphite Furnace Atomic Absorption (i.e. EPA 200.9)

<sup>[b]</sup> ½ the USEPA specified MLs for Method 1613.

## II. MONITORING LOCATIONS

The Discharger shall monitor at the following locations to demonstrate compliance with the effluent limitations, discharge specifications, and other requirements in this Order.

**Table E-2. Monitoring Station Locations**

Type of Sampling Location	Monitoring Location Name	Monitoring Location Description
Treated Process Wastewater	EFF-001	At any point after full treatment and before contact with Suisun Bay
Storm Water	EFF-002	At any point where storm water representative of that discharged at Discharge Point 002, including all storm water flow tributary to that outfall, is present.
Storm Water	EFF-003	At any point where storm water representative of that discharged at Discharge Point 003, including all storm water flow tributary to that outfall, is present
Storm Water	EFF-004	At any point where storm water representative of that discharged at Discharge Point 004, including all storm water flow tributary to that outfall, is present
Storm Water	EFF-005	At any point where storm water representative of that discharged at Discharge Point 005, including all storm water flow tributary to that outfall, is present
Storm Water	EFF-006	At any point where storm water representative of that discharged at Discharge Point 006, including all storm water flow tributary to that outfall, is present
Storm Water	EFF-007	At any point where storm water representative of that discharged at Discharge Point 007, including all storm water flow tributary to that outfall, is present
Storm Water	EFF-008	At any point where storm water representative of that discharged at Discharge Point 008, including all storm water flow tributary to that outfall, is present
Storm Water	EFF-009	At any point where storm water representative of that discharged at Discharge Point 009, including all storm water flow tributary to that outfall, is present
Storm Water	EFF-010	At any point where storm water representative of that discharged at Discharge Point 010, including all storm water flow tributary to that outfall, is present

Type of Sampling Location	Monitoring Location Name	Monitoring Location Description
Storm Water	EFF-011	At any point where storm water representative of that discharged at Discharge Point 011, including all storm water flow tributary to that outfall, is present
Storm Water	EFF-016	At any point where storm water representative of that discharged at Discharge Point 016, including all storm water flow tributary to that outfall, is present
Storm Water	EFF-017	At any point where storm water representative of that discharged at Discharge Point 017, including all storm water flow tributary to that outfall, is present

### III. INFLUENT MONITORING REQUIREMENTS

Not Applicable.

### IV. EFFLUENT MONITORING REQUIREMENTS

#### A. Treated Process Wastewater Monitoring

The Discharger shall monitor treated effluent at EFF-001 as follows:

**Table E-3. Treated Process Wastewater Monitoring**

Parameter	Units	Sample Type	Minimum Sampling Frequency
Flow Rate <sup>[1]</sup>	MGD	Continuous	1/Day
Oil and Grease <sup>[2]</sup>	mg/L	Grab, C-24	1/Week
pH <sup>[3]</sup>	s.u.	Continuous	Continuous
Temperature	°C	Continuous	Continuous
BOD <sub>5</sub>	mg/L, lbs/day	C-24	1/Month
TSS	mg/L, lbs/day	C-24	1/Week
COD	mg/L, lbs/day	C-24	1/Month
Settleable Matter	mL/L-hr	Grab	1/Month
Sulfide	mg/L, lbs/day	Grab	1/Month
Ammonia N	mg/L, lbs/day	Grab	1/Month
Total Chromium	lbs/day	C-24	1/Month
Hexavalent Chromium	lbs/day	Grab	1/Month
Phenolics Compounds (4AAP)	lbs/day	C-24	1/Month
Copper	µg/L	C-24	1/Month
Cyanide	µg/L	C-24	1/Month
Dioxin-TEQ	µg/L	C-24	2/Year
Selenium	µg/L	C-24	1/Week
Zinc	µg/L	C-24	1/Month
Acute Toxicity <sup>[4]</sup>	% survival	C-24	1/Week
Chronic Toxicity <sup>[5]</sup>	TUc	C-24	1/Quarter
Aluminum <sup>[6]</sup>	µg/L	C-24	1/Month
Remaining Priority Pollutants <sup>[7]</sup>	µg/L	C-24	2/Year
Standard Observations	---	---	Daily

[1] Flows shall be monitored continuously and the following shall be reported in monthly SMRs:

- a. Daily average flow rate (MGD),

- b. Daily total flow volume (MG),
  - c. Monthly average flow rate (MGD),
  - d. Monthly total flow volume (MG), and
  - e. Average daily maximum and average daily minimum flow rates (MGD) in a month.
- [2] Each oil and grease sample shall consist of a composite sample comprised of three grab samples taken at equal intervals during the sampling date, with each grab sample being collected in a glass container. The grab samples shall be mixed in proportion to the instantaneous flow rates occurring at the time of each grab sample, within the accuracy of plus or minus 5%. Each glass container used for sample collection or mixing shall be thoroughly rinsed with solvent rinsings as soon as possible after use, and the solvent rinsings shall be added to the composite sample for extraction or analysis.
- [3] If pH is monitored continuously, the minimum and maximum pH values for each day shall be reported in monthly self-monitoring reports.
- [4] Acute bioassay tests shall be performed in accordance with MRP section V.A.
- [5] Critical Life Stage Toxicity Tests shall be performed and reported in accordance with the Chronic Toxicity Requirements specified in MRP section V.B.
- [6] The Discharger shall monitor for both total and acid soluble aluminum.
- [7] Sampling for all priority pollutants is addressed in the Regional Standard Provisions (Attachment G).

## B. Storm Water Monitoring

The Discharger shall monitor storm water discharges at EFF-002 through -011, and EFF-016 through -017 as summarized in the following table. This Order does not address storm water discharged through Discharge Points 012 through 015 to the City of Benicia sanitary sewer system; however, the refinery must meet applicable pretreatment requirements imposed by local agencies. Compliance monitoring for Outfall 010 may be used to represent Outfall 009 as well because the flow from Outfall 009 is relatively small and the nature of the storm water from this area is expected to be similar to that at Outfall 010. However, Outfall 009 shall be monitored directly at least once in the wet season and once in the dry season over a 5-year period (see Table E-4, footnote 4).

**Table E-4. Storm Water Monitoring**

Parameter	Units	Sample Type	Minimum Sampling Frequency	Outfalls
Flow	MGD	Continuous	1/Month <sup>[1]</sup>	All
TOC	mg/L	Grab <sup>[2]</sup>	1/Quarter	All
Oil and Grease	mg/L	Grab <sup>[2]</sup>	1/Quarter	All
pH	s.u.	Grab <sup>[2]</sup>	1/Quarter	All
Specific Conductance	µmhos/cm	Grab <sup>[2]</sup>	1/Quarter	All
BOD <sub>5</sub>	mg/L	Grab <sup>[2]</sup>	1/Quarter	<sup>[3]</sup>
TSS	mg/L	Grab <sup>[2]</sup>	1/Quarter	<sup>[3]</sup>
COD	mg/L	Grab <sup>[2]</sup>	1/Quarter	<sup>[3]</sup>
Phenolic Compounds	mg/L	Grab <sup>[2]</sup>	1/Quarter	<sup>[3]</sup>
Total Chromium	µg/L	Grab <sup>[2]</sup>	1/Quarter	<sup>[3]</sup>
Hexavalent Chromium	µg/L	Grab <sup>[2]</sup>	1/Quarter	<sup>[3]</sup>
Priority Pollutants <sup>[4,5]</sup>	µg/L	Grab <sup>[2]</sup>	2/Year	Any two outfalls <sup>[4]</sup>

<sup>[1]</sup> The monthly cumulative rainfall shall be measured, and the total volume of storm water discharged for each month shall be calculated based on the drainage area served by each discharge point. The monthly rainfall amount and the monthly discharge volume for each discharge point shall be reported on a monthly basis.

- [2] Grab samples shall be collected within the first 30 minutes of a storm event.
- [3] If and when effluent limitations for this pollutant become effective in accordance with section IV.B.2 of this Order, monitoring shall begin at the outfalls where the limitations are in effect.
- [4] The priority pollutants in storm water shall be monitored two times per year, one time in the dry season and one time in the wet season. Outfalls are to be selected from among Outfalls E-003, E-006, E-009, and E-010 only. Each monitoring event shall occur at a different storm water discharge point so that in a five year period storm water outfalls E-003, E-006, E-009 and E-010 shall each be monitored at least once in the wet season and once in the dry season.
- [5] Priority pollutants are those toxic pollutants identified as compound nos. 1 – 126 by the California Toxics Rule (CTR) at 40 CFR 131.38.

## V. WHOLE EFFLUENT TOXICITY TESTING

The Discharger shall monitor acute and chronic toxicity at EFF-001 as described below.

### A. Whole Effluent Acute Toxicity

1. Compliance with the acute toxicity effluent limitations of this Order shall be evaluated by measuring survival of test organisms exposed to 96-hour continuous flow-through bioassays.
2. Test organisms shall be rainbow trout or fathead minnow unless the Executive Officer specifies otherwise in writing.
3. All bioassays shall be performed according to the most up-to-date protocols in 40 CFR 136, currently in *Methods for Measuring the Acute Toxicity of Effluents and Receiving Water to Freshwater and Marine Organisms*, 5<sup>th</sup> Edition.
4. If the Discharger demonstrates that specific identifiable substances in the discharge are rapidly rendered harmless upon discharge to the receiving water, compliance with the acute toxicity limit may be determined after the test samples are adjusted to remove the influence of those substances. Written approval from the Executive Officer must be obtained to authorize such an adjustment.
5. Effluent used for fish bioassays must be dechlorinated prior to testing. Monitoring of the bioassay water shall include, on a daily basis, the following parameters: pH, dissolved oxygen, ammonia (if toxicity is observed), temperature, hardness, and alkalinity. These results shall be reported. If a violation of acute toxicity requirements occurs, the bioassay test shall be repeated with new fish as soon as practical and shall be repeated until a test fish survival rate of 90 percent or greater is observed. If the control fish survival rate is less than 90 percent, the bioassay test shall be restarted with new fish and shall continue as soon as practical until an acceptable test is completed (i.e., control fish survival rate is 90 percent or greater).

### B. Whole Effluent Chronic Toxicity

1. Monitoring Requirements
  - a. *Sampling*. The Discharger shall collect 24-hour composite samples of the effluent at EFF-001 for critical life stage toxicity testing as indicated below. For toxicity tests

- requiring renewals, 24-hour composite samples collected on consecutive days are required.
- b. *Test Species.* Chronic toxicity shall be monitored using critical life stage tests(s) and the most sensitive test species identified by screening phase testing. At the time of this permit adoption, the approved species is *Mysidopsis bahia*. The Executive Officer may change to another test species if data suggest that another test species is more sensitive to the discharge.
  - c. *Methodology.* Sample collection, handling and preservation shall be in accordance with USEPA protocols. In addition, bioassays shall be conducted in compliance with the most recently promulgated test methods, as shown in Appendix E-1. These are *Short-Term Methods for Estimating the Chronic Toxicity of Effluents and Receiving Waters to Marine and Estuarine Organisms*, currently third edition (EPA-821-R-02-014), and *Short-term Methods for Estimating the Chronic Toxicity of Effluents and Receiving Waters to Freshwater Organisms*, currently fourth Edition (EPA-821-R-02-013), with exceptions granted the Discharger by the Executive Officer and the Environmental Laboratory Accreditation Program (ELAP).
  - d. *Dilution Series.* The Discharger shall conduct tests at 50%, 25%, 10%, 5%, and 2.5%. The "%" represents percent effluent as discharged.
  - e. *Accelerated Monitoring.* The Discharger shall accelerate monitoring to occur monthly when either of the following conditions is exceeded:
    - (1) Three sample median value of 10 chronic toxicity units (TUc), or
    - (2) Single sample maximum value of 20 TUc.
2. Reporting Requirements
- a. *Routine Reporting.* Toxicity test results for the current reporting period shall include, at a minimum, for each test:
    - (1) Sample dates
    - (2) Test initiation date
    - (3) Test species
    - (4) End point values for each dilution (e.g., number of young, growth rate, percent survival)
    - (5) NOEC values in percent effluent
    - (6) IC<sub>15</sub>, IC<sub>25</sub>, IC<sub>40</sub>, and IC<sub>50</sub> values (or EC<sub>15</sub>, EC<sub>25</sub> ... etc.) as percent effluent
    - (7) TUc values (100/NOEC, 100/IC<sub>25</sub>, or 100/EC<sub>25</sub>)
    - (8) Mean percent mortality ( $\pm$ s.d.) after 96 hours in 100% effluent (if applicable)



- (9) NOEC and LOEC values for reference toxicant tests
  - (10) IC50 or EC50 values for reference toxicant tests
  - (11) Available water quality measurements for each test (pH, dissolved oxygen, temperature, conductivity, hardness, salinity, ammonia)
- b. *Compliance Summary.* The results of the chronic toxicity testing shall be provided in the self-monitoring report and shall include a summary table of chronic toxicity data from at least eleven of the most recent samples. The information in the table shall include items listed above under 2.a, specifically item numbers (1), (3), (5), (6)[IC<sub>25</sub> or EC<sub>25</sub>], (7), and (8).
3. Toxicity Reduction Evaluation (TRE)
- a. To be ready to respond to toxicity events, the Discharger shall prepare a generic TRE work plan within 90 days of the effective date of this Order. The Discharger shall review and update the work plan as necessary to remain current and applicable to the discharge and discharge facilities.
  - b. Within 30 days of exceeding either trigger for accelerated monitoring, the Discharge shall submit to the Regional Water Board a specific TRE work plan, which should be the generic work plan revised as appropriate for this toxicity event after consideration of available discharge data.
  - c. Within 30 days of the date of completion of the accelerated monitoring tests observed to exceed either trigger, the Discharger shall initiate a TRE in accordance with a TRE work plan that incorporates any and all comments from the Executive Officer.
  - d. The TRE shall be specific to the discharge and be prepared in accordance with current technical guidance and reference materials, including USEPA guidance materials. The TRE shall be conducted as a tiered evaluation process, as summarized below:
    - (1) Tier 1 consists of basic data collection (routine and accelerated monitoring).
    - (2) Tier 2 consists of evaluation of optimization of the treatment process, including operation practices and in-plant process chemicals.
    - (3) Tier 3 consists of a toxicity identification evaluation (TIE).
    - (4) Tier 4 consists of evaluation of options for additional effluent treatment processes.
    - (5) Tier 5 consists of evaluation of options for modifications of in-plant treatment processes.
    - (6) Tier 6 consists of implementation of selected toxicity control measures, and follow-up monitoring and confirmation of implementation success.
  - e. The TRE may be ended at any stage if monitoring finds there is no longer consistent toxicity (complying with requirements of section IV.A.4 of this Order).

- f. The objective of the TIE shall be to identify the substance or combination of substances causing the observed toxicity. All reasonable efforts using currently available TIE methods shall be employed.
- g. As toxic substances are identified or characterized, the Discharger shall continue the TRE by determining the sources and evaluating alternative strategies for reducing or eliminating the substances from the discharge. All reasonable steps shall be taken to reduce toxicity to levels consistent with chronic toxicity evaluation parameters.
- h. Many recommended TRE elements parallel required or recommended efforts of source control, pollution prevention, and storm water control programs. TRE efforts should be coordinated with such efforts. To prevent duplication of efforts, evidence of complying with requirements or recommended efforts of such programs may be acceptable to comply with TRE requirements.
- i. The Regional Water Board recognizes that chronic toxicity may be episodic and identification of causes of, and reduction of, sources of chronic toxicity may not be successful in all cases. Consideration of enforcement action by the Regional Water Board will be based in part on the Discharger's actions and efforts to identify and control or reduce sources of consistent toxicity.

## VI. RECEIVING WATER MONITORING REQUIREMENTS

The Discharger shall continue to participate in the Regional Monitoring Program (RMP), which involves collection of data on pollutants and toxicity in water, sediment and biota of the Estuary. The Discharger's participation and support of the RMP is used in consideration of the level of receiving water monitoring required by this Order.

The Discharger shall also monitor Sulfur Springs Creek, Beaver Creek, and Buffalo Wallow for the standard observations listed in the Regional Standard Provisions (Attachment G) at least once per month, and once during each storm event.

## VII. LEGEND FOR MRP TABLES

### Types of Samples

C-24 = composite sample, 24 hours (includes continuous sampling, such as for flows)

### Frequency of Sampling

1/Week = once each week

1/Month = once each month

1/Quarter = once each calendar quarter (at about three month intervals)

2/Year = twice each calendar year (at about 6 months intervals, once during dry season, once during wet season)

### Parameter and Unit Abbreviations

BOD<sub>5</sub> = 5-day biochemical oxygen demand

COD = chemical oxygen demand

TUc = chronic toxicity units

°C = degrees Celsius

DO	=	dissolved oxygen
µg/L	=	micrograms per liter
µmhos/cm	=	micromhos/centimeter
MG	=	million gallons
MGD	=	million gallons per day
mg/L	=	milligrams per liter
ml/L-hr	=	milliliters per liter, per hour
MPN/100 ml	=	most probable number per 100 milliliters
% survival	=	percent survival
PAHs	=	polycyclic aromatic hydrocarbons
lbs/day	=	pounds per day
TSS	=	total suspended solids
s.u.	=	standard pH units

## VIII. REPORTING REQUIREMENTS

### A. General Monitoring and Reporting Requirements

The Discharger shall comply with all Federal Standard Provisions (Attachment D) and Regional Standard Provisions (Attachment G) related to monitoring, reporting, and recordkeeping.

### B. Self Monitoring Reports (SMRs)

- At any time during the term of this Order, the State or Regional Water Board may notify the Discharger to electronically submit SMRs using the State Water Board's California Integrated Water Quality System (CIWQS) Program Web site (<http://www.waterboards.ca.gov/ciwqs/index.html>). Until such notification is given, the Discharger shall submit hard copy SMRs. The CIWQS Web site will provide additional directions for SMR submittal in the event there will be service interruption for electronic submittal.
- The Discharger shall report in each SMR the results for all monitoring specified in this MRP under sections III through X. The Discharger shall submit monthly and annual SMRs including the results of all required monitoring using USEPA-approved test methods or other test methods specified in this Order. If the Discharger monitors any pollutant more frequently than required by this Order, the results of this monitoring shall be included in the calculations and reporting of the data submitted in the SMR. Monthly SMRs shall be due on the 30th day following the end of each calendar month, covering samples collected during that calendar month; Annual Reports shall be due on February 1 following each calendar year.
- Monitoring periods and reporting for all required monitoring shall be completed according to the following schedule:

**Table E-5. Monitoring Periods and Reporting Schedule**

Sampling Frequency	Monitoring Period Begins On...	Monitoring Period
Continuous	Day after permit effective date	All
Hourly	Day after permit effective date	Hourly

<b>Sampling Frequency</b>	<b>Monitoring Period Begins On...</b>	<b>Monitoring Period</b>
Daily	Day after permit effective date	Midnight through 11:59 PM or any 24-hour period that reasonably represents a calendar day for purposes of sampling.
Weekly	Sunday following permit effective date or on permit effective date if on a Sunday	Sunday through Saturday
Monthly	First day of calendar month following permit effective date or on permit effective date if that date is first day of the month	1 <sup>st</sup> day of calendar month through last day of calendar month
Quarterly	Closest of January 1, April 1, July 1, or October 1 following (or on) permit effective date	January 1 through March 31 April 1 through June 30 July 1 through September 30 October 1 through December 31
Semiannually	Closest of January 1 or July 1 following (or on) permit effective date	January 1 through June 30 July 1 through December 31
Annually	January 1 following (or on) permit effective date	January 1 through December 31
Per Discharge Event	Anytime during the discharge event or as soon as possible after aware of the event	At a time when sampling can characterize the discharge event

4. The Discharger shall report with each sample result the applicable Reporting Level (RL) and the current Method Detection Limit (MDL), as determined by the procedure in 40 CFR 136.

The Discharger shall report the results of analytical determinations for the presence of chemical constituents in a sample using the following reporting protocols:

- a. Sample results greater than or equal to the RL shall be reported as measured by the laboratory (i.e., the measured chemical concentration in the sample).
- b. Sample results less than the RL, but greater than or equal to the laboratory's MDL, shall be reported as "Detected, but Not Quantified" or DNQ. The estimated chemical concentration of the sample shall also be reported.

For the purposes of data collection, the laboratory shall write the estimated chemical concentration next to DNQ as well as the words "Estimated Concentration" (may be shortened to "Est. Conc."). The laboratory may, if such information is available, include numerical estimates of the data quality for the reported result. Numerical estimates of data quality may be percent accuracy ( $\pm$  a percentage of the reported value), numerical ranges (low to high), or any other means considered appropriate by the laboratory.

- c. Sample results less than the laboratory's MDL shall be reported as "Not Detected" or ND.
- d. Dischargers are to instruct laboratories to establish calibration standards so that the ML (or its equivalent if there is differential treatment of samples relative to calibration standards) is the lowest calibration standard. At no time is the Discharger to use

analytical data derived from *extrapolation* beyond the lowest point of the calibration curve.

5. The Discharger shall submit SMRs in accordance with the following requirements:
  - a. The Discharger shall arrange all reported data in a tabular format. The data shall be summarized to clearly illustrate whether the facility is operating in compliance with effluent limitations. The Discharger is not required to duplicate the submittal of data entered in a tabular format within CIWQS. When electronic submittal of data is required and CIWQS does not provide for entry into a tabular format within the system, the Discharger shall electronically submit the data in a tabular format as an attachment.
  - b. The Discharger shall attach a cover letter to the SMR. The information in the cover letter shall clearly identify violations of the Waste Discharge Requirements (WDRs), discuss corrective actions taken or planned, and specify the proposed time schedule for corrective actions. Identified violations shall include a description of the requirement that was violated and a description of the violation.
  - c. SMRs shall be submitted to the Regional Water Board, signed and certified as required by the Federal Standard Provisions (Attachment D), to the address listed below:

California Regional Water Quality Control Board  
 San Francisco Bay Region  
 1515 Clay Street, Suite 1400  
 Oakland, CA 94612  
 ATTN: NPDES Wastewater Division

**C. Discharge Monitoring Reports (DMRs)**

1. As described in section XII.B.1 above, at any time during the term of this Order, the State or Regional Water Board may notify the Discharger to electronically submit SMRs that will satisfy federal requirements for submittal of DMRs. Until such notification is given, the Discharger shall submit DMRs in accordance with the requirements described below.
2. DMRs shall be signed and certified as required by the Federal Standard Provisions (Attachment D). The Discharger shall submit the original DMR and one copy of the DMR to one of the addresses listed below:

Standard Mail	FedEx/UPS/Other Private Carriers
State Water Resources Control Board Division of Water Quality c/o DMR Processing Center PO Box 100 Sacramento, CA 95812-1000	State Water Resources Control Board Division of Water Quality c/o DMR Processing Center 1001 I Street, 15 <sup>th</sup> Floor Sacramento, CA 95814

3. All discharge monitoring results shall be reported on the official USEPA pre-printed DMR forms (EPA Form 3320-1). Forms that are self-generated will not be accepted unless they follow the exact same format as EPA Form 3320-1.

**D. Other Reports**

Annually, with the first monthly SMR following the respective due dates, the Discharger shall report the results of any special studies, monitoring, and reporting required by section VI.C.2 (Special Studies, Technical Reports, and Additional Monitoring Requirements) of this Order. The Discharger shall include a report of progress toward meeting compliance schedules set forth in section VI.C.2 of this Order.

**APPENDIX E-1**  
**CHRONIC TOXICITY**  
**DEFINITION OF TERMS AND SCREENING PHASE REQUIREMENTS**

**I. Definition of Terms**

- A. No observed effect level (NOEL) for compliance determination is equal to IC<sub>25</sub> or EC<sub>25</sub>. If the IC<sub>25</sub> or EC<sub>25</sub> cannot be statistically determined, the NOEL shall be equal to the NOEC derived using hypothesis testing.
- B. Effective concentration (EC) is a point estimate of the toxicant concentration that would cause an adverse effect on a quantal, "all or nothing," response (such as death, immobilization, or serious incapacitation) in a given percent of the test organisms. If the effect is death or immobility, the term lethal concentration (LC) may be used. EC values may be calculated using point estimation techniques such as probit, logit, and Spearman-Kärber. EC<sub>25</sub> is the concentration of toxicant (in percent effluent) that causes a response in 25 percent of the test organisms.
- C. Inhibition concentration (IC) is a point estimate of the toxicant concentration that would cause a given percent reduction in a nonlethal, nonquantal biological measurement, such as growth. For example, an IC<sub>25</sub> is the estimated concentration of toxicant that would cause a 25 percent reduction in average young per female or growth. IC values may be calculated using a linear interpolation method such as USEPA's Bootstrap Procedure.
- D. No observed effect concentration (NOEC) is the highest tested concentration of an effluent or a toxicant at which no adverse effects are observed on the aquatic test organisms at a specific time of observation. It is determined using hypothesis testing.

**II. Chronic Toxicity Screening Phase Requirements**

- A. The Discharger shall perform screening phase monitoring:
  - 1. Subsequent to any significant change in the nature of the effluent discharged through changes in sources or treatment, except those changes resulting from reductions in pollutant concentrations attributable to source control efforts, or
  - 2. Prior to permit reissuance. Screening phase monitoring data shall be included in the NPDES permit application for reissuance. The information shall be as recent as possible, but may be based on screening phase monitoring conducted within 5 years before the permit expiration date.
- B. Design of the screening phase shall, at a minimum, consist of the following elements:
  - 1. Use of test species specified in **Appendix E-2**, attached, and use of the protocols referenced in those tables, or as approved by the Executive Officer.
  - 2. Two stages:

- a. Stage 1 shall consist of a minimum of one battery of tests conducted concurrently. Selection of the type of test species and minimum number of tests shall be based on **Appendix E-2** (attached).
  - b. Stage 2 shall consist of a minimum of two test batteries conducted at a monthly frequency using the three most sensitive species based on the Stage 1 test results and as approved by the Executive Officer.
3. Appropriate controls.
  4. Concurrent reference toxicant tests.
  5. Dilution series 100%, 50%, 25%, 10%, 5%, 0 %, where “%” is percent effluent as discharged, or as otherwise approved the Executive Officer.
- C. The Discharger shall submit a screening phase proposal acceptable to the Executive Officer. The proposal shall address each of the elements listed above. If within 30 days, the Executive Officer does not comment, the Discharge shall commence with screening phase monitoring.



## APPENDIX E-2 SUMMARY OF TOXICITY TEST SPECIES REQUIREMENTS

### Critical Life Stage Toxicity Tests for Estuarine Waters

Species	(Scientific Name)	Effect	Test Duration	Reference
Alga	<i>(Skeletonema costatum)</i> <i>(Thalassiosira pseudonana)</i>	Growth rate	4 days	1
Red alga	<i>(Champia parvula)</i>	Number of cystocarps	7–9 days	3
Giant kelp	<i>(Macrocystis pyrifera)</i>	Percent germination; germ tube length	48 hours	2
Abalone	<i>(Haliotis rufescens)</i>	Abnormal shell development	48 hours	2
Oyster Mussel	<i>(Crassostrea gigas)</i> <i>(Mytilus edulis)</i>	Abnormal shell development; percent survival	48 hours	2
Echinoderms - Urchins Sand dollar	<i>(Strongylocentrotus purpuratus,</i> <i>S. franciscanus)</i> <i>(Dendraster excentricus)</i>	Percent fertilization	1 hour	2
Shrimp	<i>(Mysidopsis bahia)</i>	Percent survival; growth	7 days	3
Shrimp	<i>(Holmesimysis costata)</i>	Percent survival; growth	7 days	2
Topsmelt	<i>(Atherinops affinis)</i>	Percent survival; growth	7 days	2
Silversides	<i>(Menidia beryllina)</i>	Larval growth rate; percent survival	7 days	3

#### Toxicity Test References:

- American Society for Testing Materials (ASTM). 1990. Standard Guide for Conducting Static 96-Hour Toxicity Tests with Microalgae. Procedure E 1218-90. ASTM, Philadelphia, PA.
- Short-term Methods for Estimating the Chronic Toxicity of Effluent and Receiving Waters to West Coast Marine and Estuarine Organisms. EPA/600/R-95/136. August 1995.
- Short-term Methods for Estimating the Chronic Toxicity of Effluent and Receiving Waters to Marine and Estuarine Organisms. EPA/600/4-90/003. July 1994.

### Critical Life Stage Toxicity Tests for Fresh Waters

Species	(Scientific Name)	Effect	Test Duration	Reference
Fathead minnow	<i>(Pimephales promelas)</i>	Survival; growth rate	7 days	4
Water flea	<i>(Ceriodaphnia dubia)</i>	Survival; number of young	7 days	4
Alga	<i>(Selenastrum capricornutum)</i>	Cell division rate	4 days	4

#### Toxicity Test Reference:

- Short-term Methods for Estimating the Chronic Toxicity of Effluents and Receiving Waters to Freshwater Organisms, third edition. EPA/600/4-91/002. July 1994.

### Toxicity Test Requirements for Stage One Screening Phase

Requirements	Receiving Water Characteristics	
	Discharges to Coast	Discharges to San Francisco Bay <sup>[2]</sup>

	<b>Ocean</b>	<b>Marine/Estuarine</b>	<b>Freshwater</b>
Taxonomic diversity	1 plant 1 invertebrate 1 fish	1 plant 1 invertebrate 1 fish	1 plant 1 invertebrate 1 fish
Number of tests of each salinity type: Freshwater <sup>[1]</sup> Marine/Estuarine	0 4	1 or 2 3 or 4	3 0
Total number of tests	4	5	3

[1] The freshwater species may be substituted with marine species if:

- (a) The salinity of the effluent is above 1 part per thousand (ppt) greater than 95 percent of the time, or
- (b) The ionic strength (TDS or conductivity) of the effluent at the test concentration used to determine compliance is documented to be toxic to the test species.

- [2] (a) Marine/Estuarine refers to receiving water salinities greater than 1 ppt at least 95 percent of the time during a normal water year.  
(b) Fresh refers to receiving water with salinities less than 1 ppt at least 95 percent of the time during a normal water year.

**ATTACHMENT F – FACT SHEET****Table of Contents**

I.	Permit Information.....	F-3
II.	Facility Description.....	F-4
	A. Description of Wastewater Treatment or Controls.....	F-4
	B. Discharge Points and Receiving Waters .....	F-7
	C. Summary of Existing Requirements and Self-Monitoring Report (SMR) Data .....	F-9
	D. Compliance Summary .....	F-12
	E. Planned Changes .....	F-13
III.	Applicable Plans, Policies, and Regulations.....	F-13
	A. Legal Authorities.....	F-13
	B. California Environmental Quality Act (CEQA).....	F-13
	C. State and Federal Regulations, Policies, and Plans .....	F-13
	D. Impaired Water Bodies on CWA 303(d) List .....	F-14
IV.	Rationale For Effluent Limitations and Discharge Specifications .....	F-15
	A. Discharge Prohibitions .....	F-15
	B. Technology-Based Effluent Limitations .....	F-16
	1. Scope and Authority.....	F-16
	2. Applicable Technology-Based Effluent Limitations.....	F-16
	C. Water Quality-Based Effluent Limitations (WQBELs) for Toxic Substances .....	F-17
	1. Scope and Authority.....	F-17
	2. Applicable Beneficial Uses and Water Quality Objectives.....	F-17
	3. Determining the Need for WQBELs .....	F-20
	4. WQBEL Calculations.....	F-25
	5. Selenium Mass Emission Limitation.....	F-35
	6. Whole Effluent Acute Toxicity .....	F-36
	7. Whole Effluent Chronic Toxicity.....	F-36
	D. Interim Effluent Limitation for Dioxin-TEQ .....	F-39
	E. Land Discharge Specifications.....	F-40
	F. Reclamation Specifications .....	F-40
V.	Rationale for Receiving Water Limitations .....	F-40
VI.	RationaleE for Monitoring and Reporting Requirements.....	F-40
	A. Influent Monitoring .....	F-40
	B. Effluent Monitoring.....	F-40
	C. Whole Effluent Toxicity Testing Requirements .....	F-41
	D. Receiving Water Monitoring.....	F-41
VII.	Rationale for Provisions.....	F-42
	A. Standard Provisions (Provision VI.A).....	F-42
	B. Monitoring and Reporting Requirements (Provision VI.B).....	F-42
	C. Special Provisions (Provision VI.C) .....	F-42
	1. Reopener Provisions.....	F-42
	2. Special Studies and Additional Monitoring .....	F-42
	3. Best Management Practices and Pollution Minimization Program.....	F-43
	4. Other Special Provisions .....	F-43
VIII.	Public Participation.....	F-45
	A. Notification of Interested Parties.....	F-45

B. Written Comments .....	F-45
C. Public Hearing .....	F-46
D. Waste Discharge Requirements Petitions.....	F-46
E. Information and Copying .....	F-46
F. Register of Interested Persons .....	F-46
G. Additional Information.....	F-46

### List of Tables

Table F-1. Facility Information .....	F-3
Table F-2. Outfall Location .....	F-7
Table F-3a. Summary of Previous Effluent Limitations and Monitoring Data, Discharge Point 001 .....	F-10
Table F-3b. Summary of Previous Effluent Limitations and Monitoring Data for Toxic Pollutants, Discharge Point 001 .....	F-10
Table F-4. Previous Storm Water Effluent Limitations .....	F-11
Table F-5. Storm Water Quality .....	F-11
Table F-6. Numeric Effluent Exceedances.....	F-12
Table F-7. Beneficial Uses .....	F-18
Table F-8. Translators for Copper and Nickel for Deepwater Discharges North of Dumbarton Bridge .....	F-20
Table F-9. Summary of RPA Results .....	F-22
Table F-10. Effluent Limit Calculations.....	F-35

**ATTACHMENT F – FACT SHEET**

As described in section II of this Order, this Fact Sheet includes the legal requirements and technical rationale that serve as the basis for the requirements of this Order.

This Order has been prepared under a standardized format to accommodate a broad range of discharge requirements for dischargers in California. Only those sections or subsections of this Order that are specifically identified as “not applicable” have been determined not to apply to this Discharger. All other sections or subsections of this Order apply fully to this Discharger.

**I. PERMIT INFORMATION**

The following table summarizes administrative information related to the Valero Benicia Refinery.

**Table F-1. Facility Information**

<b>WDID</b>	2 482004001
<b>Discharger</b>	Valero Refining Company–California
<b>Name of Facility</b>	Valero Benicia Refinery
<b>Facility Address</b>	3400 East Second Street
	Benicia, CA 94510
	Solano County
<b>Facility Contact, Title, Phone</b>	Marcus Cole, Environmental Engineer, (707) 745-7807
<b>Authorized Person to Sign and Submit Reports</b>	Douglas Comeau, Vice President and General Manager
<b>Mailing Address</b>	3400 East Second Street, Benicia, CA, 94510
<b>Billing Address</b>	Same as Mailing Address
<b>Type of Facility</b>	Petroleum Refinery
<b>Major or Minor Facility</b>	Major
<b>Threat to Water Quality</b>	1
<b>Complexity</b>	A
<b>Pretreatment Program</b>	NA
<b>Reclamation Requirements</b>	N
<b>Mercury Discharge Requirements</b>	Yes, under Order No. R2-2007-0077
<b>Facility Hydraulic Capacity</b>	3.7 million gallons per day (MGD)
<b>Average Facility Flow (2008)</b>	1.93 MGD
<b>Watershed</b>	Suisun Basin
<b>Receiving Water</b>	Suisun Bay, Carquinez Strait
<b>Receiving Water Type</b>	Estuarine

- A. The Valero Refining Company-California (hereinafter Discharger) is the owner and operator of the Valero Benicia Refinery.

For the purposes of this Order, references to the “discharger” or “permittee” in applicable federal and State laws, regulations, plans, or policy are held to be equivalent to references to the Discharger herein.

- B.** The Discharger discharges treated wastewater and storm water runoff into Suisun Bay and Carquinez Strait, waters of the State and United States, and is currently regulated by National Pollutant Discharge Elimination System (NPDES) Permit No. CA000550 through Order No. 2002-0112 (hereinafter previous permit), which was adopted on January 1, 2003. The Discharger's discharge is also currently regulated by Order No. 2008-0077 (NPDES Permit CA0038849) that superseded all requirements on mercury from wastewater discharges in the region. The mercury permit is unaffected by this Order.
- C.** The Discharger filed a Report of Waste Discharge and submitted an application for reissuance of its Waste Discharge Requirements (WDRs) and NPDES permit on May 31, 2007. Because the Discharger submitted a complete and timely application for permit reissuance, the previous permit was administratively extended past its expiration date of November 30, 2007.

## **II. FACILITY DESCRIPTION**

### **A. Description of Wastewater Treatment or Controls**

The Discharger owns and operates a petroleum refinery that processes an average crude oil volume of approximately 135,000 bbls/d, producing hydrocarbon products, byproducts, and intermediates. The average crude oil volume processed is expected to increase to 165,000 bbls/d during the term of this Order. The average discharge flow rate as of 2008 was 1.93 MGD; the hydraulic capacity of the treatment plant is approximately 3.7 MGD.

Wastewaters treated by the refinery's wastewater treatment plant include stripped sour water, cooling tower and boiler blowdown water, crude water draw from on-site and off-site storage facilities, raw water treatment backwash, storm water runoff from process areas, extracted groundwater from on-site remediation processes, and monitoring well purge water from off-site service stations owned by the Discharger. Three separate wastewater streams enter the plant; sour water, combined process water and storm water, and benzene-containing oily water. After initial treatment, process water, storm water, and benzene-containing oily water are combined into an oily wastewater stream. Although an Asphalt Plant is on refinery grounds and is part of refinery processes, process wastewater and storm water from this area is discharged to the City of Benicia municipal sewer system and is therefore not authorized or regulated by this Order.

Process water and storm water first flow through strainers into surge and equalization tanks, before treatment by corrugated plate separators (CPS) and induced static flotation (ISF) units to remove oils and solids. Benzene-containing oily water is initially treated in a separate set of CPS and ISFs before also flowing to the equalization tanks. Sour water is initially treated by the sour water stripper. Most of the sour water stripper effluent is pretreated in two activated sludge (pre-Biox) units before being combined with the oily wastewater stream. The remaining stripped sour water is combined directly with the oily wastewater stream. This final combined wastewater is then treated in an activated sludge (Biox) system consisting of three aeration basins and three clarifiers operated in parallel with an addition of powdered activated carbon. The wastewater then flows to an induced air flotation (IAF) unit for additional solids removal. From the IAF unit, the wastewater flows to a reactor clarifier, where ferric chloride is added to co-precipitate selenite and polymer is added to enhance flocculation. Sodium hydroxide is added to adjust the pH of the reactor clarifier effluent, which is sent to a final discharge sump/pond (final pond). The final pond is unlined and has a capacity of approximately 2.4 million gallons (MG). It provides some flow equalization for the

discharge pumps. Treated wastewater is pumped from the final pond to Discharge Point 001 and discharged to Suisun Bay, a water of the State and United States.

When analysis of treated wastewater in the final pond indicates that it may violate effluent limitations, discharge to Suisun Bay is halted and the effluent is pumped to the crude field retention pond, which has a capacity of 23 MG. Effluent stored in the crude field retention pond is returned to the wastewater treatment plant for full or partial treatment or, if further analysis indicates that effluent limits are met, is returned to the final pond for discharge.

Components of the refinery's wastewater treatment plant are described in greater detail below.

Sour water stripper: Ammonia and hydrogen sulfide are stripped from the sour water. Effluent from the sour water stripper flows through the stripped sour water sewer to the pre-Biox unit.

Deoiler: The deoiler, which consists of a CPS and an ISF system, treats benzene-containing oily water before it flows to the equalization tanks. Removed oil is sent to the slop tanks. The deoiler is not operated continuously.

Strainers: The process water and storm water flow through strainers upstream of the surge tanks for grit removal. Grit is transported off-site for disposal.

Surge and equalization tanks: The surge and equalization tanks, which are typically operated at about 60 percent of their capacity, provide surge capacity for process water and storm water influent. The tanks store approximately 500,000 gallons of first flush storm water before flow is diverted to the storm water retention ponds. Vapors are routed to an abatement device.

Storm water retention ponds: The storm water retention ponds have an 18 MG capacity, enough for a 20-year storm. When the influent flow rate to the wastewater treatment plant exceeds 2,600 gallons per minute, and the surge and equalization tanks are full, influent flow is diverted to the storm water retention ponds. This water is ultimately returned to the wastewater treatment plant upstream of the Biox system. The storm water ponds are unlined.

Corrugated plate separators: The CPS remove oil and suspended solids from the oily wastewater stream by gravity separation, using corrugated plates to increase efficiency and reduce residence time. Oil removed by these units is stored in an oil collection drum and removed to the slop tanks. Solids removed by these units are routed to the on-site fluid coker, along with the ISF float and wasted activated sludge, via the primary sludge thickener and the cone and baker tanks. Vapors are routed to an abatement device. The CPS units can be bypassed for maintenance.

Induced static flotation: The ISF units remove remaining oil and suspended solids from the oily wastewater stream through coagulation, flocculation, and flotation processes. The float is routed to the primary sludge thickener. Vapors from the ISF units are routed to an abatement device.

Pre-Biox: The two pre-Biox units are used to pre-treat a portion of the stripped sour water in a manner similar to the Biox system. The effluent is sent to the Biox system.

Biox system: The Biox system is an activated sludge system consisting of three aeration cells and three clarifiers operated in parallel. All flow to the wastewater treatment plant goes through the Biox system. Powdered activated carbon is added to each aeration cell to absorb toxicants and otherwise improve effluent quality. The clarifiers separate treated wastewater from the biological solids. Biological solids are returned to the Biox unit to maintain biomass health and density, with a portion being periodically wasted to the activated sludge thickener.

Induced air flotation: The IAF system provides additional solids removal by introducing air to float residual solids, which are skimmed off the top. The solids are pumped to the waste activated sludge thickener.

Surge tank and reactor clarifier: The surge tank provides surge capacity for the IAF effluent. The reactor clarifier uses ferric chloride to co-precipitate selenite, a process which requires pH adjustment and polymer addition to enhance flocculation. Removed solids are pumped to the iron sludge thickener. Effluent from the reactor clarifier goes to Tank TK-2078 for pH control.

Tank TK-2078: Sodium hydroxide is added to the reactor clarifier effluent to increase pH as necessary.

Final pond: Treated wastewater flows to the final pond, which provides flow equalization. Treated wastewater is then discharged into Suisun Bay through a submerged diffuser approximately 1,100 feet offshore. If treated wastewater in the final pond does not meet effluent limitations, it can be pumped to the crude field retention pond for storage until it can be routed back to the wastewater treatment plant. During periods of water conservation, treated wastewater from the final pond can be used for fire-fighting purposes.

Wet well: The wet well provides a collection area for the wastewater treatment area drains and activated sludge thickener water. Water is pumped out of the wet well to the CPS inlet.

Primary sludge thickener: The primary sludge thickener provides solids thickening for CPS and ISF sludge. Water from the primary sludge thickener is routed upstream of the CPS or sent directly to the Biox system. Vapors are routed to an abatement device.

Oil collection drum: The oil collection drum holds oil removed by the CPS before it is returned to the slop oil system. Vapors are routed to carbon canisters for abatement.

Cone tank and baker tanks: The cone and baker tanks are used as holding tanks for sludges from the primary sludge thickener and the waste activated sludge thickener. These sludges are transported in vacuum trucks to the on-site fluid coker for reuse or are sent off-site for disposal. Vapors from the cone and baker tanks are routed to carbon canisters for abatement.

Waste activated sludge thickener: The waste activated sludge and skimmed solids from the aeration cells are accumulated in a thickener tank to separate water from the solids. The settled sludge is pumped back to the cone tank or baker tanks. Decanted water flows to the wet well and is pumped to the CPS inlet.

Iron sludge thickener: Sludge from the bottom of the reactor clarifier is pumped to the thickener for gravity dewatering. Decanted water from the thickener is returned to the reactor clarifier.



The refinery also has several storm water discharge points (Discharge Points 002 – 017), as described in Table F-2. Discharges from the certain areas near the Discharger’s crude tank field and under the Discharger’s crude pipeline (designated Discharge Points 012 through 015) that discharge to the City of Benicia sanitary sewer system are not regulated by this Order, and are instead regulated by the City.

Historically, storm water from drainage areas in the Refinery Tank Farm and Crude Oil Storage Area has been routed to the refinery’s wastewater treatment plant for treatment and discharge via Discharge Point 001. These areas are bermed to contain the contents of the largest tank within each area in the event of a tank or pipeline leak or other failure. Discharge piping from these areas is controlled by valves that are normally closed. Storm water from these areas can only be released manually, by an operator, and any discharge from them must be monitored at all times to comply with the Discharger’s Spill Prevention, Control, and Countermeasures Plan.

During the term of this Order, drainage modifications will be made to route storm water from the Refinery Tank Farm and Crude Oil Storage Area for possible discharge via Discharge Points 003, 006, 009, and 010. These drainage modifications will route drainage from 67 acres within the Lower Tank Farm to Discharge Point 003. Storm water from 63 acres within the Intermediate Tank Farm will be routed to Discharge Points 009 and 010; and 32 acres within the Crude Oil Storage Area will drain to Discharge Point 006. These discharge points and the drainage area served by each are described in greater detail below (Table F-2). The refinery expects that removing this relatively clean and dilute storm water from the wastewater treatment plant influent will result in improved and more efficient treatment. The refinery will retain the ability to route these storm water flows to the wastewater treatment plant if necessary to prevent a violation of storm water effluent limits. To ensure that of storm water effluent limits will not be violated as a result of storm water flows from the areas described above, storm water will be visually monitored for oil and color, and sampled and analyzed for TOC, TSS, and pH, at minimum, prior to discharge from these areas. Storm water not compliant with the effluent limits in Table 11 of this Order, in Table 12 if it applies, or exceeding 100 mg/L TSS will be sent to the wastewater treatment plant, treated, and discharged as treated wastewater through outfall 001.

## B. Discharge Points and Receiving Waters

The locations of the Valero Benicia Refinery Discharge Points 001 – 011 and 016 - 017, and the corresponding receiving waters, are shown in Table F-2 below.

**Table F-2. Outfall Location**

Discharge Point	Effluent Description	Discharge Point Latitude	Discharge Point Longitude	Receiving Water
001	Treated refinery wastewater	38°, 03', 18" N	122°, 07', 07" W	Suisun Bay
002	Storm water from unpaved area of 1.8 acres used for equipment storage along western boundary of wastewater treatment plant, discharged at NW corner of wastewater treatment area via ditch and several pipes into Sulfur Springs Creek and ultimately Suisun Bay. Drainage area is separated from wastewater treatment area and storm water retention pond by a dike.	38°, 03', 53" N	122°, 07', 37" W	Suisun Bay via Sulfur Springs Creek
003	Storm water from unpaved 19 acre area of the refinery and Lower Level Tank Farm (67 acres), discharged near the Raw Water Break Tank at north end of Avenue A via culvert to Sulfur Springs Creek and ultimately Suisun Bay. Discharge	38°, 04', 49" N	122°, 08', 12" W	Suisun Bay via Sulfur Springs Creek

Discharge Point	Effluent Description	Discharge Point Latitude	Discharge Point Longitude	Receiving Water
	from the Lower Level Tank Farm is controlled by a containment valve that is normally closed and must be opened manually by an operator. Tank Farm contributions are visually monitored and sampled prior to discharge. Storm water from the Tank Farm that does not meet storm water effluent limits is sent to the refinery's wastewater treatment plant. Drainage area is separated from the refinery processing area by peripheral roads around processing area.			
004	Storm water from 0.5 acre gravel area between 1st Street and railway on south side of 1st Street, discharged west of Gate 4 into eastern end of Beaver Creek, which flows to culvert, then Buffalo Wallow, then 72 inch culvert into Sulfur Springs Creek, and ultimately Suisun Bay. Drainage area is separated from processing area by peripheral road.	38°, 03', 59" N	122°, 07', 58" W	Suisun Bay via Beaver Creek, Buffalo Wallow, and Sulfur Springs Creek
005	Storm water from 68.9 acres west of processing area, discharged west of Gate 4 on south side of processing area via spillway into western end of Beaver Creek. Beaver Creek flows to culvert, which joins Buffalo Wallow, and then 72 inch culvert that drains to Sulfur Springs Creek, and ultimately Suisun Bay. Drainage area, of which less than 1 acre is impervious, is separated from the processing area by railroad tracks and peripheral road, and is bordered on south side by Gate 5 Road and on west side by refinery fence.	38°, 03', 58" N	122°, 08', 05" W	Suisun Bay via Beaver Creek, Buffalo Wallow, and Sulfur Springs Creek
006	Condensate from steam traps, groundwater seepage and storm water from 3.5 acre area beneath refinery crude pipeline (starting at southwest corner of crude tank field and running northeast along perimeter of tank farm and Park Road) and storm water from Crude Oil Storage Area (COSA) Tank Farm (32 acres). Condensate, ground water seepage, and storm water from beneath crude pipeline is collected in concrete sump equipped with containment valve and hydrocarbon detector that automatically closes containment valve and alarms the central control house in event of hydrocarbon detection. When contamination is observed or detected, water in sump is collected with vacuum trucks and treated in refinery's wastewater treatment plant. Discharge from the Crude Oil Storage Area is controlled by a containment valve that is normally closed and must be opened manually by an operator. Crude Oil Storage Area contributions are visually monitored and sampled prior to discharge. Storm water not meeting storm water effluent limits is sent to the wastewater treatment plant. Point of discharge is on south side of Park Road to Sulfur Springs Creek and ultimately to Suisun Bay.	38°, 03', 50" N	122°, 07', 57" W	Suisun Bay via Sulfur Springs Creek
007	Storm water from 0.7 acres of gravel and paved area near Gate 4, discharged east of Gate 4 to Buffalo Wallow, which flows into 72 inch culvert, to Sulfur Springs Creek, and ultimately Suisun Bay. The drainage area, of which 0.4 acres are impervious, is separated from processing area by peripheral road.	38°, 04', 02" N	122°, 07', 54" W	Suisun Bay via Buffalo Wallow and Sulfur Springs Creek
008	Storm water from 0.9 acre gravel area along railway and refinery fence line, discharged east of Gate 4 to culvert, which flows to Buffalo Wallow, then to 72 inch culvert, then to Sulfur Springs Creek and ultimately Suisun Bay. Drainage area is separated from processing area by railway.	38°, 04', 02" N	122°, 07', 53" W	Suisun Bay via Buffalo Wallow and Sulfur Springs Creek
009	Storm water from 0.3 acre gravel and paved area between railway and Avenue A and adjacent to Upper Level Tank	38°, 04', 12" N	122°, 07', 53" W	Suisun Bay via Sulfur

Discharge Point	Effluent Description	Discharge Point Latitude	Discharge Point Longitude	Receiving Water
	Farm (ULTF), discharged to culvert along Avenue A on southeast side of processing area to Sulfur Springs Creek and ultimately Suisun Bay. Approximately 0.1 acres of drainage area is impervious.			Springs Creek
010	Storm water from 0.8 acres of gravel and paved area between railway and Avenue A and adjacent to ULTF, as well as storm water from area of ULTF (63 acres). Discharge from the ULTF is controlled by a containment valve that is normally closed and must be opened manually by an operator. ULTF contributions are visually monitored and sampled prior to discharge. Storm water not meeting storm water effluent limits is sent to the wastewater treatment plant. Discharge occurs on SE side of processing area via culvert along Avenue A, which flows to Sulfur Springs Creek and ultimately to Suisun Bay. Drainage area, of which 0.25 acres is impervious, is separated from processing area by railway and peripheral road.	38°, 04', 12" N	122°, 07', 53" W	Suisun Bay via Sulfur Springs Creek
011	Storm water from 0.4 acres beneath refinery crude pipeline on north side of Park Road, discharged on north side of Park Road via culvert into Sulfur Springs Creek and ultimately Suisun Bay. Drainage area is contained with asphalt berms to channel storm water to concrete sump equipped with hydrocarbon detector, which alarms at the central control house in event of hydrocarbon release, and containment valve, which is closed until manually opened. If contamination is observed or detected, storm water from sump is collected with vacuum trucks and treated in refinery wastewater treatment system.	38°, 03', 52" N	122°, 07', 57" W	Suisun Bay via Sulfur Springs Creek
016	Storm water from 0.1 acres from beneath refinery crude pipeline south of Outfall 15 near refinery dock, discharged via culvert to Carquinez Strait. Drainage area is contained on both sides by asphalt berms, which direct storm water to concrete sump equipped with hydrocarbon detector that alarms the central control house if hydrocarbons are detected, and containment valve kept normally in the closed position. If contamination is observed or detected, storm water from sump is collected with vacuum trucks and treated in refinery wastewater treatment system.	38°, 02', 44" N	122°, 07', 45" W	Carquinez Strait
017	Storm water from approximately 12.1 acres (of which 4.25 acres are impervious) at Asphalt Plant, collected in 0.425 million gallon holding tank before discharge to Buffalo Wallow. Storm water is released from holding tank in batches via underground culvert to Buffalo Wallow, which flows to 72 inch culvert, then to Sulfur Springs Creek, and ultimately Suisun Bay.	38°, 03', 58" N	122°, 08', 05" W	Suisun Bay via Buffalo Wallow and Sulfur Springs Creek

### C. Summary of Existing Requirements and Self-Monitoring Report (SMR) Data

1. Effluent limitations in the previous permit and representative monitoring data for Discharge Point 001 are summarized below.

**Table F-3a. Summary of Previous Effluent Limitations and Monitoring Data, Discharge Point 001**

Parameter	(units)	Effluent Limitations		Monitoring Data (From 1/02 To 3/09)	
		Monthly Average	Daily Maximum	Highest Monthly Average	Highest Daily Discharge
BOD <sub>5</sub>	lb/day	1400	2500	180	303
	kg/day	640	1200	82	138
COD	lb/day	9900	19000	3370	4990
	kg/day	4500	8600	1530	2270
TSS	lb/day	1100	1800	698	1370
	kg/day	510	800	317	620
Oil and Grease	lb/day	410	770	<179	502
	kg/day	190	350	81	228
Phenolic Compounds	lb/day	9.3	19	2.1	9.2
	kg/day	4.2	8.6	0.94	4.2
Ammonia as N	lb/day	770	1700	61	395
	kg/day	350	770	28	179
Sulfide	lb/day	7.5	17	5.5	5.8
	kg/day	3.4	7.6	2.5	2.6
Settleable Solids	mL/L/hr	0.1	0.2	<0.1	1
Total Chromium	lb/day	14	39	<0.21	<0.18
	kg/day	6.3	18	<0.095	<0.082
Hexavalent Chromium	lb/day	1.1	2.6	<0.40	<0.14
	kg/day	0.51	1.2	<0.18	<0.064

## Notes :

BOD<sub>5</sub> = 5-day Biochemical Oxygen Demand  
 COD = Chemical Oxygen Demand  
 kg/day = kilograms per day  
 mL/L/hr = milliliters per liter per hour  
 lb/day = pounds per day  
 TSS = Total Suspended Solids

**Table F-3b. Summary of Previous Effluent Limitations and Monitoring Data for Toxic Pollutants, Discharge Point 001**

Parameter	Units	Final Limits		Interim Limits		Monitoring Data (From 11/02 To 3/09)
		Daily Maximum	Monthly Average	Daily Maximum	Monthly Average	Highest Daily Concentration
Copper	µg/L	---	---	36	---	22
Mercury	µg/L	---	---	---	0.075	0.17
Nickel	µg/L	---	---	65	---	26
Selenium	µg/L	---	---	50	---	268.5
Zinc	µg/L	565	245	---	---	230
Cyanide	µg/L	---	---	25	---	42
Hexavalent chromium	µg/L	116	58	---	---	8.4
4,4-DDE	µg/L	0.0012	0.00059	---	---	ND (0.002) <sup>(1)</sup>
Dieldrin	µg/L	0.00028	0.00014	---	---	ND (0.0019) <sup>(1)</sup>
PAHs	µg/L	0.098	0.049	---	---	ND (0.019) <sup>(1)</sup>

Parameter	Units	Final Limits		Interim Limits		Monitoring Data (From 11/02 To 3/09)
		Daily Maximum	Monthly Average	Daily Maximum	Monthly Average	Highest Daily Concentration
PCBs Sum	µg/L	0.00034	0.00017	---	---	ND (0.028) <sup>(1)</sup>
Dioxin-TEQ	µg/L	---	---	---	1.4 x 10 <sup>-7</sup>	9.4 x 10 <sup>-7</sup>
Ammonia (N)	mg/L	---	---	---	---	19

<sup>(1)</sup> Analyte not detected in effluent. Number in parenthesis is the MDL as reported by the analytical laboratory.

Notes:

µg/L = micrograms per liter

PCB = Polychlorinated biphenyl

PAH = polynuclear aromatic hydrocarbon

TEQ = Toxic Equivalents relative to 2,3,7,8-tetrachlorodibenzo-p-dioxin

- The previous permit (section B.9) established the following effluent limitations, based on the requirements of *Effluent Limitations Guidelines for the Petroleum Refining Point Source Category*, for discharges of storm water through Discharge Points 002 – 011 and 016 – 017.

**Table F-4. Previous Storm Water Effluent Limitations**

Pollutant	Daily Maximum Effluent Limitation
Oil & Grease	15 mg/L
TOC	110 mg/L

Notes:

mg/L = milligrams per liter

In its Report of Waste Discharge, the Discharger provided the following characterization of its storm water discharges through Discharge Points 002 – 011 and 016 – 017.

**Table F-5. Storm Water Quality**

Discharge Point	Oil & Grease (mg/L)		TOC (mg/L)		TSS (mg/L)	
	Average	Daily Maximum	Average	Daily Maximum	Average	Daily Maximum
002	< 5	< 5	13	38	54	174
003	< 5	< 5	< 23	109	214	4,010
004	< 5	< 5	< 23	109	214	4,010
005	< 5	9.2	< 20	95	123	1,754
006	< 5	14	< 15	63	147	1,053
007	< 7	21	< 20	43	647	1,968
008	< 9	30	< 14	43	761	4,633
009	< 5	< 5	< 10	19	174	524
010	< 5	< 5	< 10	19	174	524
011	< 5	10	< 8	20	207	818
016	< 5	6.2	14	32	2,337	27,400
017	< 5	7.0	< 8	34	60	200

Notes

TOC = Total Organic Carbon

TSS = Total Suspended Solids

Violations of the storm water effluent limits are discussed in subsection D below. Although the previous permit had no TSS effluent limit for storm water, the TSS levels in storm water

exceeded the benchmark value of 100 mg/L contained in USEPA's NPDES Stormwater Multi-Sector General Permit for Industrial Activities (Federal Register Volume 65, Number 210, October 30, 2000) at least once at each storm water outfall. The average storm water TSS level exceeded the benchmark value at all but two storm water outfalls. This Order requires that the Discharger document the potential cause(s) of these elevated values, and propose Best Management Practices, including sediment and erosion controls, as appropriate, to reduce TSS in storm water below the benchmark value. This is discussed further in Fact Sheet section VII.C.4.e.

#### D. Compliance Summary

Exceedances of numeric effluent limits that occurred during the previous permit term are summarized in the following table.

**Table F-6. Numeric Effluent Exceedances**

Date of Violation	Discharge Point	Exceeded Parameter	Units	Effluent Limitation	Reported Concentration
April 21, 2003	006	pH	s.u.	Max 8.5	8.6
July 12, 2004	001	Acute Toxicity	% Survival	Min 70	25
July 22, 2004	001	Acute Toxicity	% Survival	Min 70	45
August 11, 2004	001	Acute Toxicity	% Survival	Min 70	25
October 19, 2004	007	Oil and Grease	mg/L	15	21
November 27, 2004	005	pH	s.u.	Min 6.5	6.2
January 5, 2005	001	Total Settleable Solids	mL/l-hr	0.2	1
May 8, 2005	001	Acute Toxicity	% Survival	Min 70	60
June 1, 2005	001	Acute Toxicity	% Survival	Min 70	40
June 9, 2005	001	Cyanide	µg/L	25	26
December 18, 2005	008	Oil and Grease	mg/L	15	29
January 1, 2006	001	Cyanide	µg/L	25	33
January 31, 2006	001	Dioxin-TEQ	µg/L	$1.4 \times 10^{-7}$	$5.4 \times 10^{-7}$
February 16, 2006	001	Cyanide	µg/L	25	30
February 20, 2006	001	Selenium	µg/L	50	268
March 14, 2007	001	Cyanide	µg/L	25	42
December 28, 2007	009	Oil & Grease	mg/L	15	224
September 30, 2008	001	Oil & Grease	mg/L	8	9.2

The Discharger's acute toxicity monitoring data from 2002-2009 show that there were several exceedances of the 11-sample 90<sup>th</sup> percentile effluent limitation of not below 70% during the permit term. The Discharger's chronic toxicity monitoring data from 2002-2007 show that there were no exceedances of the chronic toxicity limits.

The Regional Water Board took enforcement action through Order No. R2-2007-0013 and an expedited mandatory minimum penalty (MMP) settlement letter dated June 30, 2009; the State Water Board also took enforcement action through Order SWB-2008-2-0033. Order No. R2-2007-0013 fined Valero \$18,000 in MMPs for violations from January 1, 2004, to November 1, 2006, \$16,500 of which were spent to expand an existing Supplemental Environmental Project to educate middle and high school students in pollution prevention, particularly regarding plastics. The June 30, 2009, letter fined Valero a \$3,000 MMP for the cyanided effluent limit violation that occurred on March 14, 2007. Order No. SWB-2008-2-0033

consisted of a \$3,000 MMP for the December 28, 2007, Oil & Grease violation. No enforcement action been taken yet for the September 30, 2008, Oil & Grease violation.

### **E. Planned Changes**

Over the next five years, the Discharger plans to increase its crude oil throughput from 135,000 bbls/d to 165,000 bbls/d. Also in this period, storm water from the Lower Tank Farm, Intermediate Tank Farm, and Crude Oil Storage Area, which has historically been routed to the wastewater treatment plant and discharged through Discharge Point 001, will be routed to storm water Discharge Points 003, 006, 009, and 010. The storm water modifications will reduce the hydraulic load to the wastewater and enhance pollutant removal.

## **III. APPLICABLE PLANS, POLICIES, AND REGULATIONS**

The requirements in this Order are based on the requirements and authorities described in this section.

### **A. Legal Authorities**

This Order is issued pursuant to federal Clean Water Act (CWA) section 402 and implements regulations adopted by the United States Environmental Protection Agency (USEPA), and pursuant to California Water Code (CWC) Chapter 5.5, Division 7 (commencing with section 13370). It shall serve as an NPDES permit for point source discharges from this facility to surface waters. This Order also serves as WDRs pursuant to CWC Article 4, Chapter 4, Division 7 (commencing with section 13260).

### **B. California Environmental Quality Act (CEQA)**

Under CWC section 13389, this action to adopt an NPDES permit is exempt from the provisions of CEQA.

### **C. State and Federal Regulations, Policies, and Plans**

- 1. Water Quality Control Plans.** *The Water Quality Control Plan for the San Francisco Bay Basin* (Basin Plan) is the Regional Water Board's master water quality control planning document. It designates beneficial uses and water quality objectives for waters of the State, including surface waters and groundwater. It also includes programs of implementation to achieve the water quality objectives. The Basin Plan was duly adopted by the Regional Water Board and approved by the State Water Resources Control Board, USEPA, and the Office of Administrative Law (OAL), as required. Requirements of this Order implement the Basin Plan.
- 2. Thermal Plan.** The State Water Board adopted a *Water Quality Control Plan for Control of Temperature in the Coastal and Interstate Water and Enclosed Bays and Estuaries of California* (Thermal Plan) on May 18, 1972, and amended this plan on September 18, 1975. This plan contains water quality objectives (WQOs) for coastal and interstate surface waters as well as enclosed bays and estuaries. The Valero Benicia Refinery discharges to Suisun Bay and Carquinez Strait, both of which are defined as enclosed bays by the Thermal Plan. Requirements of this Order implement the Thermal Plan.

3. **National Toxics Rule (NTR) and California Toxics Rule (CTR).** USEPA adopted the NTR on December 22, 1992, which was amended on May 4, 1995, and November 9, 1999. About forty criteria in the NTR applied in California. On May 18, 2000, USEPA adopted the CTR. The CTR promulgated new toxics criteria for California and, in addition, incorporated the previously adopted NTR criteria that applied in the State. The CTR was amended on February 13, 2001. These rules contain water quality criteria for priority toxic pollutants that apply to Suisun Bay and Carquinez Strait.
4. **State Implementation Policy.** On March 2, 2000, the State Water Board adopted the *Policy for Implementation of Toxics Standards for Inland Surface Waters, Enclosed Bays, and Estuaries of California* (State Implementation Policy or SIP). The SIP became effective on April 28, 2000, with respect to the priority pollutant criteria USEPA promulgated for California through the NTR and to the priority pollutant objectives the Regional Water Board established in the Basin Plan. The SIP became effective on May 18, 2000, with respect to the priority pollutant criteria USEPA promulgated through the CTR. On February 24, 2005, the State Water Board adopted amendments to the SIP that became effective on July 13, 2005. The SIP establishes implementation provisions for priority pollutant objectives and provisions for chronic toxicity control. Requirements of this Order implement the SIP.
5. **Alaska Rule.** On March 30, 2000, USEPA revised its regulation that specifies when new and revised State and tribal water quality standards (WQS) become effective for CWA purposes [65 Fed. Reg. 24641 (April 27, 2000) (codified at 40 CFR 131.21)]. Under the revised regulation (also known as the Alaska Rule), USEPA must approve any new and revised standards submitted to USEPA after May 30, 2000, before they can be used for CWA purposes. The final rule also provides that standards already in effect and submitted to USEPA by May 30, 2000, may be used for CWA purposes, whether or not approved by USEPA.
6. **Antidegradation Policy.** 40 CFR 131.12 requires that State water quality standards include an antidegradation policy consistent with the federal policy. The State Water Board established California's antidegradation policy through State Water Board Resolution 68-16, which incorporates the federal antidegradation policy where the federal policy applies under federal law. It also requires that existing water quality be maintained unless degradation is justified based on specific findings. The Regional Water Board's Basin Plan implements, and incorporates by reference, both the State and federal antidegradation policies. The permitted discharge must be consistent with the antidegradation provisions of 40 CFR 131.12 and State Water Board Resolution No. 68-16. Antidegradation is discussed in more detail in section IV.C.8 of this Fact Sheet.
7. **Anti-Backsliding Requirements.** CWA sections 402(o)(2) and 303(d)(4) and 40 CFR 122.44(l) prohibit backsliding in NPDES permits. These anti-backsliding provisions require that effluent limitations in a reissued permit be as stringent as those in the previous permits, with some exceptions where limitations may be relaxed. Anti-backsliding is discussed in more detail in section IV.C.8 of this Fact Sheet.

#### **D. Impaired Water Bodies on CWA 303(d) List**

In November 2006, the USEPA approved a revised list of impaired water bodies prepared by the State [hereinafter referred to as the 303(d) list] pursuant to CWA section 303(d), which requires



identification of specific water bodies where it is expected that water quality standards will not be met after implementation of technology-based effluent limitations on point sources. Suisun Bay is listed as an impaired waterbody for chlordane, DDT, dieldrin, dioxin compounds, exotic species, furan compounds, mercury, nickel, PCBs, dioxin-like PCBs, and selenium. Carquinez Strait is listed as an impaired waterbody for chlordane, DDT, dieldrin, dioxins, furans, exotic species, mercury, PCBs, dioxin-like PCBs, and selenium. The SIP requires final effluent limitations for all 303(d)-listed pollutants to be consistent with total maximum daily loads (TMDLs) and associated wasteload allocations.

The Regional Water Board plans to adopt TMDLs for pollutants on the 303(d) list. TMDLs will establish wasteload allocations for point sources and load allocations for non-point sources, and will be intended to result in achieving the water quality standards for the impaired waterbodies. USEPA adopted a mercury TMDL for San Francisco Bay on February 12, 2008. Regional Water Board Order No. R2-2007-0077 regulates mercury discharge and implements the adopted mercury TMDL.

#### **IV. RATIONALE FOR EFFLUENT LIMITATIONS AND DISCHARGE SPECIFICATIONS**

The CWA requires point source dischargers to control the amount of conventional, non-conventional, and toxic pollutants discharged into waters of the United States. The control of pollutants discharged is established through effluent limitations and other requirements in NPDES permits. There are two principal bases for effluent limitations in the NPDES regulations: 40 CFR 122.44(a) requires that permits include applicable technology-based limitations and standards; and 40 CFR 122.44(d) requires that permits include water quality-based effluent limitations to attain and maintain applicable numeric and narrative water quality criteria to protect the beneficial uses of the receiving water. Where reasonable potential has been established for a pollutant, but there is no numeric objective for the pollutant, water quality-based effluent limitations may be established: (1) using USEPA criteria guidance under CWA section 304(a), supplemented where necessary by other relevant information; (2) on an indicator parameter for the pollutant of concern; or (3) using a calculated numeric water quality criterion, such as a proposed State criterion or policy interpreting the State's narrative criterion, supplemented with other relevant information, as provided in 40 CFR 122.44(d)(1)(vi).

##### **A. Discharge Prohibitions**

- 1. Discharge Prohibitions III.A (No discharge different from that described in this Order):** This prohibition is the same as in the previous permit and is based on CWC section 13260, which requires filing a Report of Waste Discharge before discharges can occur. Discharges not described in the Report of Waste Discharge, and subsequently in this Order, are prohibited.
- 2. Discharge Prohibitions III.B (No discharge that does not receive an initial dilution of at least 15:1):** This Order allows a conservative estimate of the actual initial dilution of 15:1 to calculate WQBELs for ammonia. This is discussed further in sections IV.C.4.b and b.(3) of this Order. These WQBELs would not be protective of water quality if the discharge did not actually achieve at least a 15:1 minimum initial dilution, thus this prohibition is necessary and warranted.

This Order permits discharge of storm water from 16 outfalls that do not provide an initial dilution of at least 10:1. Though, Discharge Prohibition No. 1 of the Basin Plan prohibits discharges having characteristics of particular concern that do not receive a minimum 10:1 initial dilution, the Basin Plan further indicates that the prohibition is to address discharges of treated sewage and other discharges where the treatment process is subject to upset. Since these storm water discharges do not contain treated sewage or wastewater from a treatment process subject to upset, the prohibition does not apply to these storm water discharges.

- 3 **Discharge Prohibition III.C (No bypass or overflow of untreated or partially treated wastewaters):** This prohibition is retained from the previous permit and based on 40 CFR 122.41(m) (see federal Standard Provisions, Attachment D).

## B. Technology-Based Effluent Limitations

### 1. Scope and Authority

CWA section 301(b) and 40 CFR 122.44(a) require that permits include applicable technology-based limitations and standards. Where USEPA has not yet developed technology based standards for a particular industry or a particular pollutant, CWA section 402(a)(1) and 40 CFR 125.3 authorize the use of best professional judgment (BPJ) to derive technology-based effluent limitations on a case-by-case basis. When BPJ is used, the permit must reflect specific factors outlined at 40 CFR 125.3.

USEPA has established standards of performance (technology-based limitations and standards) for the petroleum refining industry at 40 CFR 419, *Effluent Limitations Guidelines for the Petroleum Refining Point Source Category*. Subpart B of these regulations for the Cracking Subcategory apply to discharges from the Valero Benicia Refinery and have been used to develop limitations and requirements of this Order.

### 2. Applicable Technology-Based Effluent Limitations

#### a. Technology-Based Effluent Limitations - Discharge Point 001

40 CFR 419 requires that technology-based effluent limitations for Discharge point 001 be derived based on refinery production (the total crude oil throughput of the facility) and the treatment processes used. Because the refinery currently operates with a maximum crude oil throughput of 135,000 bbls/d but plans to increase production to 165,000 bbls/d during the term of this Order, this Order establishes two sets of production-based effluent limitations.

Derivation of the production-based effluent limitations based on 40 CFR 419 Subpart B is presented in detail in Attachment F-1 to this Order. In addition to these limits, limitations for settleable solids are retained from the previous permit and are based on the requirements of Basin Plan Table 4-2.

Limitations for production rates of 165,000 bbls/d will become effective only following notice of Executive Officer approval in accordance with section VI.C.5.c of this Order.

**b. Storm Water Effluent Limitations - Discharge Points 002 - 011 and 016 - 017**

Based on the requirements of 40 CFR 419 Subpart B for storm water discharges, this Order establishes technology-based limitations for Discharge Points 002 – 011 and 016 – 017. This Order also retains the narrative storm water limits of no visible oil or color.

If the limitation for total organic carbon (TOC) or oil and grease is exceeded, the additional limitations become immediately effective for the discharge point where that exceedance occurred. Derivation of the storm water effluent limitations based on 40 CFR 419 Subpart B is presented in detail in Attachment F-1 to this Order. The additional effluent limit on pH of 6.0 to 9.0 from 40 CFR 419 Subpart B is not established by this Order. The Basin Plan pH effluent limit for shallow water discharges of 6.5 to 8.5 is retained instead to satisfy anti-backsliding requirements.

**C. Water Quality-Based Effluent Limitations (WQBELs) for Toxic Substances****1. Scope and Authority**

- a. 40 CFR 122.44(d)(1)(i) requires permits to include WQBELs for pollutants (including toxicity) that are or may be discharged at levels that cause, have reasonable potential to cause, or contribute to an excursion above any State water quality standard (Reasonable Potential). The process for determining Reasonable Potential and, when necessary, calculating WQBELs is intended to (1) protect the designated beneficial uses of the receiving water, and (2) achieve applicable WQOs in the CTR, NTR, and the Basin Plan.
- b. NPDES regulations and the SIP provide the basis to establish Maximum Daily Effluent Limitations (MDELs).

**(1) NPDES Regulations.** 40 CFR 122.45(d) states “For continuous discharges all permit effluent limitations, standards, and prohibitions, including those necessary to achieve water quality standards, shall *unless impracticable* be stated as maximum daily and average monthly discharge limitations for all discharges other than publicly owned treatment works.”

**(2) SIP.** SIP section 1.4 requires that WQBELs be expressed as MDELs and average monthly effluent limitations (AMELs).

MDELs are used in this Order to protect against acute water quality effects. The MDELs are necessary for preventing fish kills or mortality to aquatic organisms.

**2. Applicable Beneficial Uses and Water Quality Objectives**

- a. Beneficial uses applicable to the receiving waters are from Basin Plan Table 2-1 and are as follows:

**Table F-7. Beneficial Uses**

Discharge Point	Receiving Water Name	Beneficial Use(s)
001, 002, 003, 004, 005, 006, 007, 008, 009, 010, 011, 017 <sup>[1]</sup>	Suisun Bay	Ocean, Commercial and Sport Fishing (COMM) Industrial Process Supply (PRO) Estuarine Habitat (EST) Industrial Service Supply (IND) Fish Migration (MIGR) Navigation (NAV) Preservation of Rare and Endangered Species (RARE) Water Contact Recreation (REC1) Non-Contact Water Recreation (REC2) Wildlife Habitat (WILD) Fish Spawning (SPWN)
016	Carquinez Strait	Ocean, Commercial and Sport Fishing (COMM) Estuarine Habitat (EST) Industrial Service Supply (IND) Fish Migration (MIGR) Navigation (NAV) Preservation of Rare and Endangered Species (RARE) Water Contact Recreation (REC1) Non-Contact Water Recreation (REC2) Wildlife Habitat (WILD) Fish Spawning (SPWN)

<sup>[1]</sup> Outfalls 002 through 011, and 017 flow to specific creeks, which flow to Suisun Bay. Beneficial uses of Suisun Bay apply to these creeks due to the Tributary Rule.

**b.** The WQOs applicable to the receiving waters for this discharge are from the Basin Plan; the CTR, established by USEPA at 40 CFR 131.38; and the NTR, established by USEPA at 40 CFR 131.36. Some pollutants have WQOs established by more than one of these three sources.

**(1) Basin Plan.** The Basin Plan specifies numeric WQOs for 10 priority toxic pollutants, as well as narrative WQOs for toxicity and bioaccumulation in order to protect beneficial uses. The pollutants for which the Basin Plan specifies numeric objectives are arsenic, cadmium, hexavalent chromium, copper in freshwater, lead, mercury, nickel, silver, zinc, and cyanide. The Basin Plan's narrative toxicity objective (section 3.3.18) states in part, "[a]ll waters shall be maintained free of toxic substances in concentrations that are lethal to or that produce other detrimental responses in aquatic organisms." The bioaccumulation objective states in part, "[c]ontrollable water quality factors shall not cause a detrimental increase in concentrations of toxic substances found in bottom sediments or aquatic life. Effects on aquatic organisms, wildlife, and human health will be considered."

**(2) CTR.** The CTR specifies numeric aquatic life criteria for 23 priority toxic pollutants and numeric human health criteria for 57 priority toxic pollutants. These criteria apply to all inland surface waters and enclosed bays and estuaries of the San Francisco Bay Region.

- (3) **NTR.** The NTR establishes numeric aquatic life criteria for selenium, numeric aquatic life and human health criteria for cyanide, and numeric human health criteria for 34 other toxic organic pollutants for waters of San Francisco Bay upstream to, and including, Suisun Bay and the Delta. These NTR criteria apply to Suisun Bay, the receiving water for this Discharger.
- (4) **Technical Support Document for Water Quality-Based Toxics Controls.** Where numeric objectives have not been established or updated in the Basin Plan, 40 CFR 122.44(d) requires that WQBELs be established based on USEPA criteria, supplemented where necessary by other relevant information, to attain and maintain narrative WQOs to fully protect designated beneficial uses. To determine the need for WQBELs and establish them when necessary, the Regional Water Board has followed the requirements of applicable NPDES regulations, including 40 CFR 122 and 131, as well as guidance and requirements established by the Basin Plan; USEPA's *Technical Support Document for Water Quality-Based Toxics Control* (the TSD, EPA/505/2-90-001, 1991); and the State Water Board's *Policy for Implementation of Toxics Standards for Inland Surface Waters, Enclosed Bays, and Estuaries of California, 2005* (SIP).
- (5) **Basin Plan Receiving Water Salinity Policy and Hardness.** The Basin Plan (like the CTR and the NTR) states that the salinity characteristics (i.e., freshwater vs. saltwater) of the receiving water shall be considered in determining the applicable WQO. Freshwater objectives shall apply to discharges to waters with salinities equal to or less than one parts per thousand (ppt) at least 95 percent of the time. Saltwater objectives shall apply to discharges to waters with salinities equal to or greater than 10 ppt at least 95 percent of the time in a normal water year. For discharges to water with salinities in between these two categories, or tidally influenced freshwaters that support estuarine beneficial uses, the objectives shall be the lower of the salt or freshwater objectives (the latter calculated based on ambient hardness) for each substance.

The receiving water for Discharge Point 001 for this Discharger, Suisun Bay, is an estuarine environment based on salinity data generated through the San Francisco Estuary Institute's Regional Monitoring Program (RMP) at the Pacheco Creek (BF10) sampling stations between 1993 and 2001. In that period, the receiving water's minimum salinity was 0.0 ppt, its maximum salinity was 12.8 ppt, and its average salinity was 4.4 ppt. Because the salinity was between 1 and 10 ppt in 33 percent of receiving water samples, the freshwater and the saltwater objectives from the Basin Plan, NTR, and CTR apply to this discharge.

Some freshwater metal objectives are hardness dependent. Hardness data is collected through the RMP for water bodies in the San Francisco Bay region. In determining the objectives for this Order, Regional Water Board staff used a hardness value of 96 mg/L, the adjusted geometric mean of the hardness values observed below 400 mg/L at the Pacheco Creek Station between 1993 and 2001. This represents the best available information for the hardness of the receiving water after it has mixed with the discharge.

**(6) Site-Specific Metal Translators.** Because 40 CFR 122.45(c) requires effluent limitations for metals to be expressed as total recoverable metal, and applicable water quality criteria for the metals are typically expressed as dissolved metal, factors or translators must be used to convert metals concentrations from dissolved to total recoverable and vice versa. In the CTR, USEPA establishes default translators that are used in NPDES permitting activities; however, site-specific conditions, such as water temperature, pH, suspended solids, and organic carbon, greatly impact the form of metal (dissolved, filterable, or otherwise) present and therefore available in the water to cause toxicity. In general, the dissolved form is more available and more toxic to aquatic life than filterable forms. Site-specific translators can be developed to account for site-specific conditions, thereby preventing exceedingly stringent or under protective water quality objectives.

For deep-water discharges to Suisun Bay, Regional Water Board staff used translators for copper and nickel based on recommendations of the Clean Estuary Partnership's *North of Dumbarton Bridge Copper and Nickel Development and Selection of Final Translators* (2005). In determining the need for and calculating WQBELs for all other metals, Regional Water Board staff used default translators from 40 CFR 131.38(b)(2), Table 2.

**Table F-8. Translators for Copper and Nickel for Deepwater Discharges North of Dumbarton Bridge**

	Copper	Nickel
AMEL Translator	0.38	0.27
MDEL Translator	0.67	0.57

### 3. Determining the Need for WQBELs

40 CFR 122.44(d)(1)(i) requires permits to include WQBELs for all pollutants (non-priority or priority) “which the Director determines are or may be discharged at a level which will cause, have the reasonable potential to cause, or contribute to an excursion above any narrative or numeric criteria within a State water quality standard” (i.e., have “Reasonable Potential”). Assessing whether a pollutant has Reasonable Potential is the fundamental step in determining whether or not a WQBEL is required. Using the methods prescribed in section 1.3 of the SIP, Regional Water Board staff analyzed the effluent data to determine if the discharge demonstrates Reasonable Potential.

#### a. Reasonable Potential Analysis

Using the methods prescribed in SIP section 1.3, Regional Water Board staff analyzed the effluent data to determine if the discharge demonstrates Reasonable Potential. The Reasonable Potential Analysis (RPA) compares the effluent data with numeric and narrative WQOs in the Basin Plan, NTR, and CTR.

#### b. Reasonable Potential Methodology

Using the methods and procedures prescribed in SIP section 1.3, Regional Water Board staff analyzed the effluent and background data and the nature of facility operations to determine if the discharge has Reasonable Potential. The RPA projects a maximum

effluent concentration (MEC) for each pollutant based on existing data, while accounting for a limited data set and effluent variability. There are three triggers in determining Reasonable Potential.

- (1) The first trigger is activated if the MEC is greater than the lowest applicable WQO ( $MEC \geq WQO$ ), which has been adjusted, if appropriate, for pH, hardness, and translator data. If the MEC is greater than the adjusted WQO, then that pollutant has Reasonable Potential, and a WQBEL is required.
- (2) The second trigger is activated if the observed maximum ambient background concentration (B) is greater than the adjusted WQO ( $B > WQO$ ) and the pollutant is detected in any of the effluent samples.
- (3) The third trigger is activated if a review of other information determines that a WQBEL is required to protect beneficial uses, even though both MEC and B are less than the WQO. A limitation may be required under certain circumstances to protect beneficial uses.

#### **c. Effluent Data**

The RPA was based on the effluent monitoring data collected by the Discharger from April 2006 through March 2009 for most inorganic pollutants, and from April 2004 through March 2009 for most organic pollutants. Regional Water Board staff analyzed these data and the nature of the discharge to determine if the discharge has Reasonable Potential.

#### **d. Ambient Background Data**

Ambient background values are used in the RPA and in the calculation of effluent limitations. For the RPA, ambient background concentrations are the observed maximum detected water column concentrations. The SIP states that for calculating WQBELs, ambient background concentrations are either the observed maximum ambient water column concentrations or, for objectives intended to protect human health from carcinogenic effects, the arithmetic mean of observed ambient water concentrations. The RMP station at Yerba Buena Island, located in the Central Bay, has been monitored for most of the inorganic (CTR constituent numbers 1–15) and some of the organic (CTR constituent numbers 16–126) toxic pollutants, and these data were used as background data in performing this RPA.

The RMP has not analyzed all the constituents listed in the CTR. On May 15, 2003, a group of several San Francisco Bay Region dischargers (known as the Bay Area Clean Water Agencies, or BACWA) submitted a collaborative receiving water study, entitled the *San Francisco Bay Ambient Water Monitoring Interim Report*. This study includes monitoring results from sampling events in 2002 and 2003 for the remaining priority pollutants not monitored by the RMP. The RPA was conducted and the WQBELs were calculated using RMP data from 1993 through 2003 for inorganics and organics at the Yerba Buena Island RMP station, and additional data from the BACWA *Ambient Water Monitoring: Final CTR Sampling Update Report* for the Yerba Buena Island RMP station.

**e. RPA Determination**

The MECs, most stringent applicable WQOs, and background concentrations used in the RPA are presented in the following table, along with the RPA results (yes or no) for each pollutant analyzed. Reasonable Potential was not determined for all pollutants because there are not applicable water quality objectives for all pollutants, and monitoring data were not available for others. The pollutants that exhibit Reasonable Potential are copper, selenium, zinc, cyanide, dioxin toxic equivalents (dioxin-TEQ), and ammonia.

**Table F-9. Summary of RPA Results**

CTR #	Priority Pollutants	MEC or Minimum DL <sup>[a][b]</sup> (µg/L)	Governing WQO/WQC (µg/L)	Maximum Background or Minimum DL <sup>[a][b]</sup> (µg/L)	RPA Results <sup>[c]</sup>
1	Antimony	0.4	4300	1.8	No
2	Arsenic	3.6	36	2.81	No
3	Beryllium	< 0.06	No Criteria	0.215	Ud
4	Cadmium	0.51	1.1	0.16	No
5a	Chromium (III)	8.1	200	Not Available	Ud
5b	Hexavalent chromium	8.4	11	4.4	No
6	Copper	14	7.2	2.55	Yes
7	Lead	0.66	3.0	0.80	No
8	Mercury (303d listed)	[d]	[d]	[d]	[d]
9	Nickel (303d listed)	23	30	3.7	No
10	Selenium (303d listed)	268.5	5	0.39	Yes
11	Silver	0.2	2.2	0.052	No
12	Thallium	0.2	6.3	0.21	No
13	Zinc	230	86	5.1	Yes
14	Cyanide	42	1	< 0.4	Yes
15	Asbestos	Not Available	No Criteria	Not Available	Ud
16	2,3,7,8-TCDD (303d listed)	< 5.98E-07	1.4E-08	8.00E-9	No
	Dioxin TEQ (303d listed)	0.000000937	1.4E-08	7.10E-08	Yes
17	Acrolein	< 0.56	780	< 0.5	No
18	Acrylonitrile	< 0.33	0.66	0.03	No
19	Benzene	20	71	< 0.05	No
20	Bromoform	< 0.07	360	< 0.5	No
21	Carbon Tetrachloride	< 0.06	4.4	0.06	No
22	Chlorobenzene	< 0.06	21000	< 0.5	No
23	Chlorodibromomethane	< 0.07	34	< 0.05	No
24	Chloroethane	< 0.07	No Criteria	< 0.5	Ud
25	2-Chloroethylvinyl ether	< 0.1	No Criteria	< 0.5	Ud
26	Chloroform	3.2	No Criteria	< 0.5	Ud
27	Dichlorobromomethane	< 0.06	46	< 0.05	No
28	1,1-Dichloroethane	< 0.05	No Criteria	< 0.05	Ud
29	1,2-Dichloroethane	< 0.06	99	0.04	No
30	1,1-Dichloroethylene	< 0.07	3.2	< 0.5	No
31	1,2-Dichloropropane	< 0.05	39	< 0.05	No
32	1,3-Dichloropropylene	< 0.05	1700	Not Available	Ud
33	Ethylbenzene	< 0.06	29000	< 0.5	No
34	Methyl Bromide	< 0.05	4000	< 0.5	No
35	Methyl Chloride	< 0.04	No Criteria	< 0.5	Ud
36	Methylene Chloride	< 0.07	1600	22	No
37	1,1,2,2-Tetrachloroethane	< 0.06	11	< 0.05	No
38	Tetrachloroethylene	< 0.06	8.9	< 0.5	No



CTR #	Priority Pollutants	MEC or Minimum DL <sup>[a][b]</sup> (µg/L)	Governing WQO/WQC (µg/L)	Maximum Background or Minimum DL <sup>[a][b]</sup> (µg/L)	RPA Results <sup>[c]</sup>
39	Toluene	2.9	200000	< 0.3	No
40	1,2-Trans-Dichloroethylene	< 0.05	140000	< 0.5	No
41	1,1,1-Trichloroethane	< 0.06	No Criteria	< 0.5	Ud
42	1,1,2-Trichloroethane	< 0.07	42	< 0.05	No
43	Trichloroethylene	< 0.06	81	< 0.5	No
44	Vinyl Chloride	< 0.05	525	< 0.5	No
45	2-Chlorophenol	< 0.6	400	< 1.2	No
46	2,4-Dichlorophenol	< 0.7	790	< 1.3	No
47	2,4-Dimethylphenol	8	2300	< 1.3	No
48	2-Methyl- 4,6-Dinitrophenol	< 0.9	765	< 1.2	No
49	2,4-Dinitrophenol	< 0.6	14000	< 0.7	No
50	2-Nitrophenol	< 0.7	No Criteria	< 1.3	Ud
51	4-Nitrophenol	< 0.6	No Criteria	< 1.6	Ud
52	3-Methyl 4-Chlorophenol	< 0.5	No Criteria	< 1.1	Ud
53	Pentachlorophenol	< 0.9	0.0059	< 1.0	No
54	Phenol	< 1	4600000	< 1.3	No
55	2,4,6-Trichlorophenol	< 0.6	6.5	< 1.3	No
56	Acenaphthene	< 0.3	2700	0.0019	No
57	Acenaphthylene	< 0.2	No Criteria	0.00053	Ud
58	Anthracene	< 0.3	110000	0.0005	No
59	Benzidine	< 0.96	0.00054	< 0.0015	No
60	Benzo(a)Anthracene	< 0.019	0.049	0.0053	No
61	Benzo(a)Pyrene	< 0.019	0.049	0.00147	No
62	Benzo(b)Fluoranthene	< 0.02	0.049	0.0046	No
63	Benzo(ghi)Perylene	< 0.1	No Criteria	0.0027	Ud
64	Benzo(k)Fluoranthene	< 0.02	0.049	0.0015	No
65	Bis(2-Chloroethoxy)Methane	< 0.77	No Criteria	< 0.3	Ud
66	Bis(2-Chloroethyl)Ether	< 0.67	1.4	< 0.3	No
67	Bis(2-Chloroisopropyl)Ether	< 0.6	170000	Not Available	Ud
68	Bis(2-Ethylhexyl)Phthalate	2	5.9	0.091	No
69	4-Bromophenyl Phenyl Ether	< 0.4	No Criteria	< 0.23	Ud
70	Butylbenzyl Phthalate	7	5200	0.0056	No
71	2-Chloronaphthalene	< 0.5	4300	< 0.3	No
72	4-Chlorophenyl Phenyl Ether	< 0.5	No Criteria	< 0.3	Ud
73	Chrysene	< 0.02	0.049	0.0024	No
74	Dibenzo(a,h)Anthracene	< 0.02	0.049	0.00064	No
75	1,2-Dichlorobenzene	< 0.2	17000	< 0.8	No
76	1,3-Dichlorobenzene	< 0.3	2600	< 0.8	No
77	1,4-Dichlorobenzene	< 0.3	2600	< 0.8	No
78	3,3 Dichlorobenzidine	< 0.3	0.077	< 0.001	No
79	Diethyl Phthalate	< 0.7	120000	< 0.24	No
80	Dimethyl Phthalate	4	2900000	< 0.24	No
81	Di-n-Butyl Phthalate	< 0.58	12000	0.016	No
82	2,4-Dinitrotoluene	< 0.6	9.1	< 0.27	No
83	2,6-Dinitrotoluene	< 0.48	No Criteria	< 0.29	Ud
84	Di-n-Octyl Phthalate	< 0.67	No Criteria	< 0.38	Ud
85	1,2-Diphenylhydrazine	< 0.6	0.54	0.0037	No
86	Fluoranthene	< 0.05	370	0.011	No
87	Fluorene	< 0.1	14000	0.0036	No
88	Hexachlorobenzene	< 0.4	0.00077	0.000022	No
89	Hexachlorobutadiene	< 0.7	50	< 0.3	No
90	Hexachlorocyclopentadiene	< 0.4	17000	< 0.31	No
91	Hexachloroethane	< 0.6	8.9	< 0.2	No

CTR #	Priority Pollutants	MEC or Minimum DL <sup>[a][b]</sup> (µg/L)	Governing WQO/WQC (µg/L)	Maximum Background or Minimum DL <sup>[a][b]</sup> (µg/L)	RPA Results <sup>[c]</sup>
92	Indeno(1,2,3-cd)Pyrene	< 0.02	0.049	0.004	No
93	Isophorone	< 0.48	600	< 0.3	No
94	Naphthalene	< 0.2	No Criteria	0.00255	Ud
95	Nitrobenzene	< 0.67	1900	< 0.25	No
96	N-Nitrosodimethylamine	< 0.58	8.1	< 0.3	No
97	N-Nitrosodi-n-Propylamine	< 0.77	1.4	< 0.001	No
98	N-Nitrosodiphenylamine	< 0.58	16	< 0.001	No
99	Phenanthrene	< 0.05	No Criteria	0.0061	Ud
100	Pyrene	< 0.05	11000	0.0194	No
101	1,2,4-Trichlorobenzene	< 0.6	No Criteria	< 0.3	Ud
102	Aldrin	< 0.002	0.00014	1.4E-07	No
103	Alpha-BHC	< 0.0028	0.013	0.000496	No
104	beta-BHC	< 0.0028	0.046	0.000413	No
105	gamma-BHC	< 0.002	0.063	0.0007034	No
106	delta-BHC	< 0.002	No Criteria	0.000053	Ud
107	Chlordane (303d listed)	< 0.005	0.00059	0.00018	No
108	4,4'-DDT (303d listed)	< 0.002	0.00059	0.000167	No
109	4,4'-DDE (linked to DDT)	< 0.002	0.00059	0.000693	No
110	4,4'-DDD	< 0.0019	0.00084	0.000313	No
111	Dieldrin (303d listed)	< 0.0019	0.00014	0.000264	No
112	Alpha-Endosulfan	< 0.0019	0.0087	0.000031	No
113	beta-Endosulfan	< 0.0019	0.0087	0.000069	No
114	Endosulfan Sulfate	< 0.002	240	0.0000819	No
115	Endrin	< 0.0019	0.0023	0.00004	No
116	Endrin Aldehyde	< 0.002	0.81	Not Available	Ud
117	Heptachlor	< 0.0028	0.00021	0.000019	No
118	Heptachlor Epoxide	< 0.0019	0.00011	0.000094	No
119-125	PCBs sum (303d listed)	< 0.028	0.00017	0.00146	No
126	Toxaphene	< 0.14	0.0002	Not Available	Ud
	Tributyltin	Not Available	0.0074	0.002	Ud
	Total PAHs	<0.019	15	0.05145	No
	Total Ammonia	<b>19,000</b>	1,201	200	<b>Yes</b>

- (a) The MEC or maximum background concentration is the actual detected concentration unless there is a "<" sign before it, in which case the value shown is the minimum detection level.
- (b) The MEC or maximum background concentration is "Not Available" when there are no monitoring data for the constituent.
- (c) RPA Results = Yes, if MEC > WQO/WQC, or B > WQO/WQC and MEC is detected;  
= No, if MEC and B are < WQO/WQC or all effluent data are undetected;  
= Undetermined (Ud), if no criteria have been promulgated;  
= Cannot Determine, if there are insufficient data.
- (d) Mercury from wastewater discharges is regulated by NPDES Permit No. CA0038849 (currently Regional Water Board Order No. R2-2007-0077) that implements the San Francisco Bay Mercury TMDL.

**(1) Constituents with limited data.** The Discharger has performed sampling and analysis for the constituents listed in the CTR. This data set was used to perform the RPA. In some cases, Reasonable Potential cannot be determined because effluent data are limited or ambient background concentrations are not available. The Discharger will continue to monitor for these constituents in the effluent using analytical methods that provide the best feasible detection limits. When additional data become available, further RPA will be conducted to determine whether to add numeric effluent limitations to this Order or to continue monitoring.

**(2) Pollutants with no Reasonable Potential.** WQBELs are not included in this Order for constituents that do not demonstrate Reasonable Potential; however, monitoring for such pollutants is still required. If concentrations of these constituents are found to have increased significantly, section VI.C.2.a of this Order requires the Discharger to investigate the source of the increase. Remedial measures are required if the increase poses a threat to water quality.

#### **4. WQBEL Calculations**

##### **a. Pollutants with Reasonable Potential**

WQBELs were developed for the toxic and priority pollutants that were determined to have Reasonable Potential. The WQBELs were calculated based on appropriate WQOs and the appropriate procedures specified in SIP section 1.4. The WQOs used for each pollutant with Reasonable Potential are discussed below.

##### **b. Dilution Credit**

The SIP provides the basis for any dilution credit. The outfall at Discharge Point 001 is designed to achieve a minimum initial dilution of 10:1. The actual dilution has been estimated using the 1985 update of the EPA-supported plume-modeling program UOUTPLM. Model results were reported in a technical report prepared by Camp, Dresser, & McKee, titled *Draft Field Dye Tracer Studies and Initial Dilution Modeling of the Benicia Refinery Wastewater Diffuser* (October 21, 1988). The worst-case initial dilution factor calculated was 15:1 at a flow rate of 1,400 gpm (2 MGD). This dilution factor was calculated at slack tide conditions with a salinity stratification of 0.55 ppt per meter. The flow rate of 2 MGD is approximately equal to the average flow rate reported by the Discharger of 1.95 MGD. Under the modeled conditions, the dilution factor increases with increasing flow rate, so the dilution factor of 15:1 calculated at approximately average flow is likely conservative.

Based on RMP monitoring data for San Francisco Bay, there is variability in the receiving water, and the hydrology of the receiving water is very complex. Therefore, it is uncertain how representative the ambient background data used to determine the effluent limitations is. Pursuant to SIP section 1.4.2.1, “dilution credit may be limited or denied on a pollutant-by-pollutant basis...” The detailed basis for each pollutant is explained below.

(1) Bioaccumulative Pollutants: For certain bioaccumulative pollutants, dilution credit is significantly restricted or denied. This determination is based on available data on concentrations of these pollutants in aquatic organisms, sediment, and the water column. Selenium, PCBs dioxin and furan compounds, dioxin-like PCBs, nickel, chlordane, dieldrin, and 4,4'-DDT appear on the CWA section 303(d) list for Suisun Bay because they impair Suisun Bay’s beneficial uses. The following factors suggest insufficient assimilative capacity in San Francisco Bay for these pollutants.

(a) Bioaccumulative Pollutants Excluding Selenium

Tissue samples taken from fish in Suisun Bay show the presence of these pollutants at concentrations greater than screening levels (*Contaminant Concentrations in Fish from San Francisco Bay*, May 1997). The results of the 1994 San Francisco Bay pilot study, presented in *Contaminated Levels in Fish Tissue from San Francisco Bay* (Regional Water Board, 1994) also showed elevated levels of chemical contaminants in fish tissues. The Office of Environmental Health and Hazard Assessment completed a preliminary review of the data in the 1994 report and subsequently issued an interim consumption advisory covering certain fish species in San Francisco Bay in December 1994. This advisory is still in effect for exposure to sport fish contaminated with mercury, dioxins, and pesticides (e.g., DDT).

Dilution credits are denied for all bioaccumulative pollutants on the 303(d) list except selenium, discussed below. Denial of dilution credits is appropriate given the lack of data and significant uncertainty about how different sources of these pollutants contribute to bioaccumulation.

(b) Selenium

For selenium, San Francisco Bay waterfowl tissue data presented in the California Department of Fish and Game's Selenium Verification Study (1986-1990) showed elevated selenium levels in the livers of waterfowl that feed on bottom-dwelling organisms, such as clams. In addition, the Office of Environmental Health and Hazard Assessment issued an advisory in 1987 for consumption of two species of diving ducks in the North Bay found to have high tissue levels of selenium. This advisory is still in effect. Elevated selenium levels have also been found in the tissue of white sturgeon, which also feed on clams.

This information, together with high uncertainty regarding how different sources of selenium contribute to bioaccumulation, have previously led the Regional Water Board to deny dilution credit for selenium. However, data collected during TMDL development have clarified the role of petroleum refinery discharges in selenium bioaccumulation, providing evidence that their role is relatively small. In addition, refineries have significantly reduced their discharges of selenium, and altered the chemical species of the selenium still discharged to a less bioavailable form. Both of these factors are discussed in more detail below. Based on this information, Regional Water Board staff concludes that limited dilution credit for selenium may be granted such that existing refinery performance is maintained, pending the completion of a selenium TMDL. Therefore, this order uses a dilution credit of  $D = 9$  (10:1 dilution) to calculate selenium WQBELs.

Selenium enters the food web primarily in particulate form, either associated with phytoplankton or organic matter, or adsorbed to particles. Bivalves, particularly the Asian clam (*Corbula Amurensis*), consume the particles and phytoplankton, causing selenium to bioaccumulate in their tissue. Selenium then bioaccumulates in higher predators that consume bivalves, such as diving ducks and white sturgeon. However, refinery-discharged selenium is all in dissolved forms, not particulate.

Also, refinery-discharged selenium to San Francisco Bay averaged 600 kilograms per year (kg/yr) from 1999 to 2006, a significantly smaller mass than the approximately 4,000 kg/yr that entered due to Sacramento and San Joaquin River flows.

Though particulate selenium is the main concern, dissolved selenium can still enter the food web when it adsorbs to particles or is taken up by phytoplankton. Dissolved selenium exists in the chemical species selenate, selenite, and selenide. Of these species, selenite is most adsorbent and is preferentially taken up by phytoplankton; selenate is least adsorbent and least readily taken up. Refinery-discharged selenium is approximately 20 percent each selenite and selenide, and 60 percent selenate (the least adsorbent form). Prior to 1998, when refineries began improving their selenium treatment, a much higher percentage (60 percent) of refinery-discharged selenium was in the selenite form or the most adsorbent form. Data also provide evidence that selenium uptake by phytoplankton in San Francisco Bay may already be at or near peak uptake regardless of refineries' contributions.

The rate at which selenate reduces to selenite is believed to be very low in San Francisco Bay because the reaction is sulfate-limited; however, there is some uncertainty about this rate and about how bioavailable selenate is to phytoplankton. Furthermore, phytoplankton reaches its maximum ability to take up dissolved selenium at relatively low water column concentrations (this is based on laboratory rather than field data; there is uncertainty about how different species and varying populations of phytoplankton might affect this process).

While these uncertainties exist, work on the TMDL has increased our understanding, and has provided evidence that the current contribution of refineries in general, and this Discharger in particular, to selenium bioaccumulation is small. This Order therefore would restrict, but does not deny, dilution credit in the calculation of WQBELs for selenium pending TMDL completion.

- (2) Non-bioaccumulative Pollutants: For non-bioaccumulative constituents (except for ammonia), a conservative dilution allowance of 10:1 ( $D = 9$ ) has been assigned. The 10:1 dilution allowance is consistent with the previous permit and is also based on Basin Plan Prohibition 1 (Table 4-1), which prohibits discharges with less than 10:1 dilution. SIP section 1.4.2 allows for limiting the dilution credit:
  - (a) A far-field background station is appropriate because the receiving water body (Suisun Bay) is a very complex estuarine system with highly variable and seasonal upstream freshwater inflows and diurnal tidal saltwater inputs. SIP section 1.4.3 allows background conditions to be determined on a discharge-by-discharge or water body-by-water body basis. Regional Water Board staff has chosen to use a water body-by-water body basis due to inherent uncertainties in characterizing ambient background conditions in a complex estuarine system on a discharge-by-discharge basis.

The Yerba Buena Island RMP monitoring station, relative to other RMP stations, fits SIP guidance criteria for establishing background conditions. The SIP requires that background water quality data be representative of the ambient receiving water that will mix with the discharge. Regional Water Board staff believe that water quality data from the Yerba Buena Island monitoring station is representative of the water that will mix with discharges from Discharge Point 001.

- (b) Because of the complex hydrology of Suisun Bay, a mixing zone has not been established. There are uncertainties in accurately determining the mixing zones for each discharge. The models that have been used to predict dilution have not considered the three dimensional nature of Suisun Bay currents resulting from the interaction of tidal flushes and seasonal fresh water outflows. Being heavier and colder than fresh water, ocean salt water enters San Francisco Bay on twice-daily tidal cycles, generally beneath the warmer fresh water that flows seaward. When these waters mix and interact, complex circulation patterns occur due to the varying densities of the fresh and ocean waters. The complex patterns occur throughout San Francisco Bay, but are most prevalent in the San Pablo, Carquinez Strait, and Suisun Bay areas. The locations of this mixing and interaction change, depending on the strength of each tide. Additionally, sediment loads from the Central Valley change on a long-term basis, affecting the depth of different parts of Suisun Bay, resulting in alteration of flow patterns, mixing, and dilution at the outfall.
- (3) Ammonia: For ammonia, a non-persistent pollutant that quickly disperses and degrades, a dilution ratio of 15:1 was used to calculate WQBELs. This is justified because ammonia is quickly dispersed and degraded to a non-toxic state, and cumulative toxicity effects are unlikely. The ratio of 15:1 represents the actual dilution estimated at Discharge Point 001.

### c. Calculation of Pollutant-Specific WQBELs

#### (1) Copper

- (a) *Copper WQOs.* The most stringent applicable WQOs for copper are the Basin Plan's site-specific chronic and acute marine WQOs, 6.0 and 9.4 micrograms per liter ( $\mu\text{g/L}$ ), respectively, expressed as dissolved metal. Regional Water Board staff converted these WQOs to total recoverable metal using site-specific translators of 0.38 (chronic) and 0.66 (acute), as recommended by the Clean Estuary Partnership's *North of Dumbarton Bridge Copper and Nickel Development and Selection of Final Translators* (2005). The resulting chronic WQOs of 16  $\mu\text{g/L}$  and acute water quality criterion of 14  $\mu\text{g/L}$  were used to perform the RPA and calculate WQBELs.
- (b) *RPA Results.* This Order establishes effluent limitations for copper because the MEC of 22  $\mu\text{g/L}$  exceeds the most stringent applicable WQO for this pollutant, demonstrating Reasonable Potential by Trigger 1.

- (c) *Copper WQBELs*. WQBELs for copper calculated according to SIP procedures using a coefficient of variation (CV) of 0.41 and a dilution credit of  $D = 9$  are an AMEL of 70  $\mu\text{g/L}$  and an MDEL of 120  $\mu\text{g/L}$ .
- (d) *Immediate Compliance Feasible*. Statistical analysis of effluent data for copper, collected over the period of April 2004 – March 2009, shows that the 95<sup>th</sup> percentile (9.7  $\mu\text{g/L}$ ) is less than the AMEL (70  $\mu\text{g/L}$ ); the 99<sup>th</sup> percentile (12  $\mu\text{g/L}$ ) is less than the MDEL (120  $\mu\text{g/L}$ ); and the mean (5.7  $\mu\text{g/L}$ ) is less than the long term average of the projected lognormal distribution of the effluent data set after accounting for effluent variability (52  $\mu\text{g/L}$ ). The Regional Water Board therefore concludes that immediate compliance with these effluent limitations is feasible.
- (e) *Anti-backsliding*. Anti-backsliding requirements are satisfied because the previous permit did not include final effluent limitations for copper.

## (2) Selenium

- (a) *Selenium WQC*. The most stringent applicable WQC for selenium are from the NTR for protection of aquatic life. The NTR establishes a saltwater and freshwater acute criterion of 20.0  $\mu\text{g/L}$  and chronic criterion of 5.0  $\mu\text{g/L}$ .
- (b) *RPA Results*. This Order establishes effluent limitations for selenium because the MEC of 44  $\mu\text{g/L}$  exceeds the most stringent applicable WQC for this pollutant, demonstrating Reasonable Potential by Trigger 1.
- (c) *Selenium WQBELs*. Based on a dilution credit of 10:1 ( $D=9$ ), WQBELs for selenium calculated according to SIP procedure using a CV of 0.25 are an AMEL of 43  $\mu\text{g/L}$  and an MDEL of 60  $\mu\text{g/L}$ . The previous permit contained no AMEL, but did require an interim MDEL of 50  $\mu\text{g/L}$ . Therefore, consistent with maintaining current performance, the WQBELs in this Order are an AMEL of 43  $\mu\text{g/L}$  and an MDEL of 50  $\mu\text{g/L}$ .
- (d) *Immediate Compliance Feasible*. Statistical analysis of effluent data for selenium collected over the period of April 2004 through March 2009 shows that the 95<sup>th</sup> percentile (38  $\mu\text{g/L}$ ) is less than the AMEL (43  $\mu\text{g/L}$ ); the 99<sup>th</sup> percentile (45  $\mu\text{g/L}$ ) is less than the MDEL (50  $\mu\text{g/L}$ ); and the mean (26  $\mu\text{g/L}$ ) is less than the long term average of the projected lognormal distribution of the effluent data set after accounting for effluent variability (35  $\mu\text{g/L}$ ). The Regional Water Board therefore concludes that immediate compliance with these effluent limitations is feasible.
- (e) *Anti-backsliding*. Anti-backsliding requirements are satisfied because the limits in this Order are not less stringent than previous permit limitations for selenium.

### (3) Zinc

- (a) *Zinc WQOs.* The most stringent applicable WQOs for zinc are the Basin Plan saltwater acute and chronic objectives for protection of aquatic life of 95 µg/L and 86 µg/L, respectively.
- (b) *RPA Results.* This Order establishes effluent limitations for zinc because the MEC (96 µg/L) exceeds the most stringent applicable WQO for this pollutant, demonstrating Reasonable Potential by Trigger 1.
- (c) *Zinc WQBELs.* WQBELs for zinc calculated according to SIP procedure using a CV of 0.66 and a dilution credit of  $D = 9$  are an AMEL of 430 µg/L and an MDEL of 900 µg/L. The previous permit contained more stringent limits of an AMEL of 240 µg/L and an MDEL of 560 µg/L.
- (d) *Immediate Compliance Feasible.* Statistical analysis of effluent data for zinc, collected over the period of April 2006 through March 2009 shows that the 95<sup>th</sup> percentile (34 µg/L) is less the AMEL in the previous permit (240 µg/L), and the 99<sup>th</sup> percentile (66 µg/L) is less than the MDEL in the previous permit (560 µg/L). The Regional Water Board therefore concludes that immediate compliance with the zinc effluent limitations in the previous permit is feasible.
- (e) *Anti-backsliding.* This Order retains the more stringent WQBELs from the previous permit, thereby satisfying anti-backsliding requirements.

### (4) Cyanide

- (a) *Cyanide WQOs.* The most stringent applicable WQOs for cyanide are the Basin Plan's site-specific chronic and acute marine WQOs, 9.4 and 2.9 µg/L, respectively, for protection of marine aquatic life in San Francisco Bay.
- (b) *RPA Results.* This Order establishes effluent limitations for cyanide because the MEC of 42 µg/L exceeds the most stringent applicable WQO of 2.9 µg/L, demonstrating Reasonable Potential by Trigger 1.
- (c) *Cyanide WQBELs.* WQBELs for cyanide calculated according to SIP procedures using the default CV of 0.6 and a dilution credit of 10:1 are an MDEL of 42 µg/L and an AMEL of 21 µg/L.
- (d) *Immediate Compliance Feasible.* With insufficient effluent data to determine the distribution of the effluent data set or to calculate a mean and standard deviation, feasibility to comply with final effluent limitations is determined by comparing the MEC (42 µg/L) to the AMEL (21 µg/L) and the MDEL (42 µg/L). Based on this comparison, and on the fact that cyanide was not detected in over 80 percent of the Discharger's effluent samples analyzed for cyanide, the Regional Water Board concludes that immediate compliance is feasible.
- (f) *Anti-backsliding.* Anti-backsliding requirements are satisfied because the previous permit did not include final effluent limitations for cyanide.



## (5) Dioxin-TEQ

- (a) *Dioxin-TEQ WQO*. The Basin Plan narrative WQO for bioaccumulative substances states:

*Many pollutants can accumulate on particulates, in sediments, or bioaccumulate in fish and other aquatic organisms. Controllable water quality factors shall not cause a detrimental increase in concentrations of toxic substances found in bottom sediments or aquatic life. Effects on aquatic organisms, wildlife, and human health will be considered.*

Because it is the consensus of the scientific community that dioxins and furans associate with particulates, accumulate in sediments, and bioaccumulate in the fatty tissue of fish and other organisms, the Basin Plan's narrative bioaccumulation WQO applies to these pollutants. Elevated levels of dioxins and furans in fish tissue in San Francisco Bay demonstrate that the narrative bioaccumulation WQO is not being met. USEPA has therefore included Suisun Bay as impaired by dioxin and furan compounds in the current 303(d) listing of receiving waters where water quality objectives are not being met after imposition of applicable technology-based requirements.

The CTR establishes a numeric WQO for 2,3,7,8-tetrachlorinated dibenzo-p-dioxin (2,3,7,8-TCDD) of  $1.4 \times 10^{-8}$  µg/L for the protection of human health when aquatic organisms are consumed. When the CTR was promulgated, USEPA stated its support of the regulation of other dioxin and dioxin-like compounds through the use of toxic equivalents (TEQs) in NPDES permits. For California waters, USEPA stated specifically, "if the discharge of dioxin or dioxin-like compounds has reasonable potential to cause or contribute to a violation of a narrative criterion, numeric WQBELs for dioxin or dioxin-like compounds should be included in NPDES permits and should be expressed using a TEQ scheme." [65 Fed. Reg. 31682, 31695 (2000)]. This procedure, developed by the World Health Organization (WHO) in 1998, uses a set of toxicity equivalency factors (TEFs) to convert the concentration of any congener of dioxin or furan into an equivalent concentration of 2,3,7,8-TCDD. This Order uses the 1998 TEF scheme and the CTR WQO for 2,3,7,8-TCDD to translate the Basin Plan's narrative bioaccumulation objective into a numeric criterion to use in the RPA and from which to derive effluent limits.

Although the 1998 WHO scheme includes TEFs for dioxin-like PCBs, they are not included in this Order's version of the TEF procedure. The CTR has established a specific water quality standard for dioxin-like PCBs, and they are included in the analysis of total PCBs.

- (b) *RPA Results*. To determine if Reasonable Potential exists for dioxin or dioxin-like compounds in this discharge, Regional Water Board staff used TEFs to express the measured concentrations of 16 dioxin congeners in effluent and background samples as 2,3,7,8-TCDD. These "equivalent" concentrations were then compared to the CTR numeric criterion for 2,3,7,8-TCDD ( $1.4 \times 10^{-8}$  µg/L).

This Order establishes effluent limitations for dioxin-TEQ because the MEC ( $9.4 \times 10^{-7}$   $\mu\text{g/L}$ ) exceeds the WQO for dioxin-TEQ translated from the bioaccumulation objective ( $1.4 \times 10^{-8}$   $\mu\text{g/L}$ ), demonstrating Reasonable Potential by Trigger 1.

- (c) *WQBELs*. WQBELs for dioxin-TEQ calculated using SIP procedures using the default CV of 0.6 and no dilution credit are an AMEL of  $1.4 \times 10^{-8}$  and an MDEL of  $2.8 \times 10^{-8}$   $\mu\text{g/L}$ .
- (d) *Immediate Compliance Infeasible*. The Discharger's Feasibility Study asserts that it cannot immediately comply with the dioxin-TEQ WQBELs. With insufficient effluent data to determine the distribution of the effluent data set or to calculate a mean and standard deviation, feasibility to comply with final effluent limitations is determined by comparing the MEC ( $9.4 \times 10^{-7}$   $\mu\text{g/L}$ ) to the AMEL ( $1.4 \times 10^{-8}$   $\mu\text{g/L}$ ) and the MDEL ( $2.8 \times 10^{-8}$   $\mu\text{g/L}$ ). In addition to the MEC exceeding the WQBELs, the variability of dioxin-TEQ measured in the effluent results in significant uncertainty regarding whether compliance is attainable. Based on this analysis, the Regional Water Board concurs with the Discharger's assertion of infeasibility to comply. This Order provides a compliance schedule for dioxin-TEQ.
- (e) *Interim Effluent Limitation*. The interim effluent limitation ( $1.4 \times 10^{-7}$   $\mu\text{g/L}$ ) from the previous permit is retained. Because the previous permit contained a ten-year compliance schedule for dioxin-TEQ, the term for this compliance schedule is continued by this Order and shall be in effect until January 1, 2013.
- (f) *Anti-backsliding*. Anti-backsliding requirements are satisfied because the previous permit did not include dioxin-TEQ effluent limitations.
- (6) Ammonia
- (a) *Ammonia WQO*. The Basin Plan contains WQOs for un-ionized ammonia of 0.025 mg/L as an annual median and 0.16 mg/L as a maximum upstream of the San Francisco Bay Bridge. Regional Water Board staff translated these WQOs from un-ionized ammonia concentrations to equivalent total ammonia concentrations (as nitrogen) since (1) sampling and laboratory methods are not available to analyze for un-ionized ammonia; and (2) the fraction of total ammonia that exists in the toxic un-ionized form depends on the pH, salinity, and temperature of the receiving water. To translate the Basin Plan un-ionized ammonia objective, Regional Water Board staff used pH, salinity, and temperature data from March 1993 to August 2003 from the nearest RMP station to the outfall (in this case, the Pacheco Creek RMP station [BF10]). Regional Water Board staff used the following equations to determine the fraction of total ammonia that would exist in the toxic un-ionized form in the estuarine receiving water where the various measurements were taken from 1993-2003 (USEPA, 1989, *Ambient Water Quality Criteria for Ammonia (Saltwater)*–1989, EPA Publication 440/5-88-004):

$$\text{For salinity} > 10 \text{ ppt: fraction of NH}_3 = \frac{1}{1 + 10^{(pK - pH)}}$$

Where:

$$pK = 9.245 + 0.116(I) + 0.0324(298 - T) + \frac{0.0415(P)}{(T)}$$

$$I = \text{Molal ionic strength of saltwater} = \frac{19.9273(S)}{(1,000 - 1.005109[S])}$$

S = Salinity (parts per thousand)

T = Temperature in degrees Kelvin

P = Pressure (one atmosphere)

Regional Water Board staff then used the 90<sup>th</sup> percentile and median un-ionized ammonia fractions from 1993 to 2003 to express the acute and chronic un-ionized ammonia WQOs as total ammonia concentrations. This approach is consistent with USEPA guidance on translating dissolved metal WQOs to total recoverable metal WQOs (USEPA, 1996, *The Metals Translator: Guidance for Calculating a Total Recoverable Limit from a Dissolved Criterion*, EPA Publication Number 823-B-96-007). The equivalent total ammonia acute and chronic WQOs calculated for this discharge are 4.6 mg/L and 1.2 mg/L, respectively.

- (b) *RPA Results*. Basin Plan section 4.5.5.2 indicates that WQBELs shall be calculated according to the SIP. Basin Plan section 3.3.20 refers to ammonia as a toxic pollutant. Therefore, The SIP methodology was used to perform the RPA and to calculate effluent limitations for ammonia. This Order establishes effluent limitations for total ammonia because the MEC of 19 mg/L exceeds the most stringent applicable translated WQO for this pollutant, demonstrating Reasonable Potential by Trigger 1.
- (c) *WQBELs*. The total ammonia WQBELs calculated according to SIP procedures using a CV of 5.27 and a dilution credit of D = 14 are an MDEL of 20 mg/L and an AMEL of 5.7 mg/L. Regional Water Board staff made statistical adjustments to the WQBEL calculations because:
- the Basin Plan's chronic WQO for un-ionized ammonia is based on an annual median instead of the typical 4-day average;
  - the SIP assumes a 4-day average concentration and monthly sampling frequency of 4 days per month to calculate effluent limitations based on chronic criteria, whereas a 365-day average and a monitoring frequency of 30 days per month, reflecting the actual basis of the WQO and actual sampling frequency, were used here.

These statistical adjustments are supported by USEPA's *Water Quality Criteria; Notice of Availability; 1999 Update of Ambient Water Quality Criteria for Ammonia*, published on December 22, 1999, in the Federal Register.

Following SIP methodology, Regional Water Board staff used the maximum ambient background total ammonia concentration to calculate effluent limitations based on the acute criterion; and the median background total ammonia concentration to calculate

effluent limitations based on the chronic criterion. Because the Basin Plan's chronic un-ionized ammonia objective is an annual median, the median background concentration is more representative of ambient conditions than a daily maximum.

- (d) *Immediate Compliance Feasible.* Statistical analysis of effluent data for total ammonia collected over the period of January 2002 through November 2007 shows that the 95<sup>th</sup> percentile (0.64 mg/L) is less than the AMEL (5.7 mg/L); the 99<sup>th</sup> percentile (18 mg/L) is less than the MDEL (20 mg/L); and the mean (0.52 mg/L) is less than the long-term average of the projected normal distribution of the effluent data set after accounting for effluent variability (1.5 mg/L). The Regional Water Board therefore conclude that immediate compliance with effluent limitations is feasible.
- (e) *Anti-backsliding.* Anti-backsliding requirements are satisfied because the previous permit did not include ammonia WQBELs.

#### **d. Effluent Limit Calculations**

Table F-10 below summarizes the effluent limit calculations.

**Table F-10. Effluent Limit Calculations**

PRIORITY POLLUTANTS	Copper	Selenium	Zinc	Cyanide	Dioxin TEQ	Ammonia	
Units	ug/L	ug/L	ug/L	ug/L	ug/L	mg/L	mg/L
Basis and Criteria type	Basin Plan SSOs	NTR Criterion for the Bay	Basin Plan & CTR SW Aquatic Life	Basin Plan SSOs	Basin Plan Narrative	Basin Plan Aquatic Life	Basin Plan Aquatic Life
CTR Criteria -Acute	-----	-----	-----	9.4	-----		
CTR Criteria -Chronic	-----	-----	-----	2.9	-----		
SSO Criteria -Acute (December 2004) (Diss.)	3.9						
SSO Criteria -Chronic (December 2004) (Diss.)	2.5						
Water Effects ratio (WER)	2.4	1	1	1	1		
Lowest WQO					1.4E-08	1.201	4.575
Site Specific Translator - MDEL	0.66	-----	-----	-----	-----		
Site Specific Translator - AMEL	0.38	-----	-----	-----	-----		
Dilution Factor (D) (if applicable)	9	9	9	9	0	14	14
No. of samples per month	4	4	4	4	4	4	4
Aquatic life criteria analysis required? (Y/N)	Y	Y	Y	Y	N	Y	Y
HH criteria analysis required? (Y/N)	N	N	N	Y	Y	N	N
Applicable Acute WQO	14.18	20	95.1	9.4			4.575
Applicable Chronic WQO	15.79	5	85.6	2.9		1.201	
HH criteria	-----	-----	-----	220000	1.4E-08		
Background (Maximum Conc for Aquatic Life calc)	2.6	0.39	5.1	0.4	7.1E-08	0.2	0.2
Background (Average Conc for Human Health calc)	-----	-----	-----	0.4	5.0E-08		
Is the pollutant Bioaccumulative(Y/N)? (e.g., Hg)	N	Y	N	N	Y	N	N
ECA acute	119	196.5	905.5	90.4		No Acute WQO	65.8
ECA chronic	135	46.490	810.3	25.4		15.2	No Chronic WQO
ECA HH				2199996	1.4E-08		
No. of data points <10 or at least 80% of data reported non detect? (Y/N)	N	N	N	Y	Y	N	N
Avg of effluent data points	5.7	25.9	15.1			5.21E-01	5.21E-01
Std Dev of effluent data points	2.3	6.5	9.9			2.75E+00	2.75E+00
CV calculated	0.41	0.25	0.66	N/A	N/A	5.27	5.27
CV (Selected) - Final	0.41	0.25	0.66	0.6	0.60	5.27	5.27
ECA acute mult99	0.43	0.58	0.30	0.32		0.08	0.08
ECA chronic mult99	0.64	0.75	0.50	0.53		0.10	0.10
LTA acute	51.6	114.1	268.4	29.0			5.0
LTA chronic	86	35.1	404.5	13.4		1.5	
minimum of LTAs	51.6	35.1	268.4	13.4		1.5	5.0
AMEL mult95	1.4	1.2	1.6	1.6	1.6	3.8	3.8
MDEL mult99	2.3	1.7	3.4	3.1	3.1	13.2	13.2
AMEL (aq life)	70	42.7	432.1	20.8		5.7	18.8
MDEL(aq life)	119	60.3	905.5	41.7		20.0	65.8
MDEL/AMEL Multiplier	1.69	1.41	2.10	2.01	2.01	3.50	3.50
AMEL (human hlth)				2199996	1.4E-08		
MDEL (human hlth)				4413609	2.8E-08		
minimum of AMEL for Aq. life vs HH	70.4	42.7	432	20.8	1.4E-08	5.7	18.8
minimum of MDEL for Aq. Life vs HH	118.9	60.3	905	41.7	2.8E-08	20.0	65.8
Current limit in permit (30-day average)	-----	-----	240	-----	1.4E-07	-----	-----
Current limit in permit (daily)	36 (Interim)	50 (interim)	560	25 (interim)	-----	-----	-----
Final limit - AMEL	70	43	240	21	1.4E-08	5.7E+00	1.9E+01
Final limit - MDEL	120	50	560	42	2.8E-08	2.0E+01	6.6E+01
Max Effl Conc (MEC)	22	45.25	96	42	9.4E-07	1.9E+01	1.9E+01

## 5. Selenium Mass Emission Limitation

SIP section 2.1.1 states that for bioaccumulative compounds on the 303(d) list, the Regional Water Board should consider whether mass-loading limits should be limited to current levels. The Regional Water Board finds that mass-loading limits are warranted for selenium. The purpose of this mass-loading limit is to further ensure that this Discharger maintains its

existing selenium treatment performance, and does not further contribute to impairment of the narrative objective for bioaccumulation in Suisun Bay, pending a TMDL.

This Order establishes a mass emission limitation for selenium of 9.6 kg/mo as a running annual average. This mass emission limitation was calculated based on the AMEL and the average daily effluent flow from January 1, 2003 to June 30, 2009 (1.94 MGD). Compliance is feasible, as the Discharger's mean effluent selenium concentration (26 ug/L) and average flow rate result in an estimated average annual selenium mass load of 5.8 kg/mo.

The previous permit's selenium mass-loading limit was 0.96 pounds per day, or 13.3 kg/mo, as a running annual average. This limit was established by Regional Water Board Order 91-026, and was based on an interim daily maximum concentration limit of 50 ug/L and the Discharger's average flow rate. The running annual average basis of the limit is retained by this Order to be consistent with the previously established limit. The limit in this Order is calculated using the AMEL instead of the MDEL because the AMEL better represents the long-term performance required of the Discharger. Anti-backsliding requirements are satisfied because the mass-loading limit in this Order is not less stringent than the previous mass-loading limit.

## 6. Whole Effluent Acute Toxicity

- a. This Order includes effluent limitations for whole-effluent acute toxicity that are unchanged from the previous permit and based on the Basin Plan. All bioassays are to be performed using the most up-to-date USEPA protocol and the most sensitive species as specified in writing by the Executive Officer based on the most recent screening test results. Bioassays shall be conducted in compliance with *Methods for Measuring the Acute Toxicity of Effluents and Receiving Water to Freshwater and Marine Organisms*, currently 5th Edition (EPA-821-R-02-012), with exceptions granted to the Discharger by the Executive Officer and the Environmental Laboratory Accreditation Program (ELAP) upon the Discharger's request with justification.
- b. If specific identifiable substances in the discharge can be demonstrated by the Discharger as being rapidly rendered harmless upon discharge to the receiving water, compliance with the acute toxicity limit may be determined after the test samples are adjusted to remove the influence of those substances. Written approval from the Executive Officer must be obtained to authorize such an adjustment.

## 7. Whole Effluent Chronic Toxicity

- a. *Permit Requirements.* This Order includes effluent limitations for chronic toxicity that are unchanged from the previous permit and based on the Basin Plan. The permit requirements for chronic toxicity are also consistent with the CTR and SIP requirements.
- b. *Screening Phase Study.* The Discharger implemented a chronic toxicity screening phase monitoring program for chronic toxicity and the results of this study have been incorporated (see Attachment E, section V.B.)

## 8. Anti-backsliding and Antidegradation

### a. Anti-backsliding

CWA sections 402(o)(2) and 303(d)(4) and 40 CFR 122.44(l) prohibit backsliding in NPDES permits. These anti-backsliding provisions require that effluent limitations in a reissued permit be as stringent as those in the previous permit, with some exceptions in which limitations may be relaxed. WQBEL calculations and compliance with anti-backsliding requirements are discussed for each pollutant with a WQBEL in Fact Sheet section IV.C.4.c.

Because the RPA showed no Reasonable Potential for hexavalent chromium, 4,4-DDE, dieldrin, PAHs (benzo[a]anthracene, benzo[a]pyrene, benzo[b]fluoranthene, chrysene, dibenzo[a,h]anthracene, and indeno[1,2,3-cd]pyrene), and total PCBs, the limitations in the previous permit are not retained in this Order. State Board Order WQ 2001-16 found, “Anti-backsliding does not necessarily dictate that a pollutant that was limited in a prior permit must have a limit in a later permit, even though the pollutant has never been detected and its discharge does not have the Reasonable Potential to cause or contribute to a water quality standards violation.” The logic of the Napa Remand Order also applies to situations where a pollutant is detected, but no longer triggers reasonable potential. The removal of limits for these pollutants is therefore consistent with State Water Board Order WQ 2001-16 and anti-backsliding requirements.

Technology-based limitations in this Order for Discharge Point 001, for both production rates (135,000 and 165,000 bbls/d), are higher (appear less stringent) than corresponding limitations in the previous permit. The method for deriving these limits is presented in the *Effluent Limitations Guidelines for the Petroleum Refining Point Source Category* (40 CFR 419) and is explained in Attachment F-1. The derivation of limits depends on the process configuration of the refinery, which, in turn, depends on the feedstock rate of each process. Based on information provided by the Discharger in its application for permit renewal, during the term of the previous permit, feedstock rates for certain refinery processes increased, resulting in different “process configuration values” used in the derivation of effluent limitations and higher effluent limitations. Such a change in effluent limitations is consistent with CWA section 402(o)(2)(A), which allows a reissued permit to include less stringent limitations when a material and substantial alteration to the permitted facility has occurred after the previous limitations became effective. In these circumstances, technology-based effluent limitations are still consistent with applicable requirements of 40 CFR 419; however, material changes in refinery processes have resulted in different factors to be considered when effluent limitations are derived.

### b. Antidegradation

Antidegradation policies require that existing water quality be maintained unless degradation is justified based on specific findings. The permitted discharge is consistent with antidegradation policies. This Order continues the level of discharge authorized in the previous permit and thus there will be no degradation of water quality. This is because this Order does not provide for an increase in the permitted design flow or allow for a reduction in the level of treatment. Also, the increased effluent limitations for copper, cyanide, and pollutants subject to limitations based on the *Effluent Limitations*

*Guidelines for the Petroleum Refining Point Source Category (40 CFR 419) (ELGs)* are consistent with antidegradation requirements as explained below.

### **Copper and Cyanide**

This Order establishes WQBELs that are higher than those in Order 2002-0112 for copper and cyanide based on recently adopted and approved site-specific objectives. The standards-setting processes for copper and cyanide addressed antidegradation. To ensure no degradation of the receiving waters, the Basin Plan requires that permits containing copper and cyanide limits based on the site-specific objectives also require copper and cyanide action plans. This Order includes such plans (see sections VI.C.5.a and b).

### **Production-Based Limits**

This Order establishes increased technology-based mass loading limits for BOD, COD, TSS, oil & grease, phenolic compounds, ammonia, sulfide, total chromium, and hexavalent chromium consistent with the ELGs. This is the result of increased feedstock rates to certain refinery processes that result in the derivation of increased effluent limitations consistent with the ELGs.

In 1990, the State Water Board adopted an administrative procedures update (APU 90-004) that specified guidance to the Regional Water Boards for implementing the State and federal antidegradation policies. The guidance states "... if the Regional Water Board has no reason to believe that existing water quality will be reduced due to the proposed action, no antidegradation analysis is required." The new mass loading limits for BOD, COD, TSS, oil & grease, phenolic compounds, ammonia (as N), sulfide, total chromium, and hexavalent chromium will not result in a significant reduction of water quality.

The total effluent flow rate is a function of production. No increase in production, and therefore in flow, is authorized unless the Discharger prepares a full antidegradation analysis as required by section VI.C.5.c of this Order.

The Discharger is also subject to a technology-based mass loading limitation on settleable solids that is the same as in Order 2002-0112, a new WQBEL for ammonia that is equivalent to a lower mass loading limit than either than in Order 2002-0112 or that in this Order, and a more stringent mass loading limit for selenium than in Order 2002-0112.

These requirements mean that the mass of BOD, COD, TSS, oil & grease, phenolic compounds, ammonia, sulfide, total chromium, and hexavalent chromium discharged is unlikely to increase despite the increased mass loading limitations. The Discharger proposes no changes to its treatment process, and no decrease in treatment is authorized. Furthermore, it is impossible for the Discharger to manipulate its treatment processes to adjust effluent levels of these pollutants independently of others. To maintain compliance with other effluent limits, the Discharger will have to at least maintain its existing performance.

The technology-based mass limitations are consistent with applicable statutes and regulations. They are derived from the ELGs for cracking refineries based on *Effluent*



*Limitations Guidelines for the Petroleum Refining Point Source Category (40 CFR 419)* and represent Best Practicable Control Technology (BPT) and Best Conventional Pollutant Control Technology (BCT). They therefore represent the best practicable treatment or control available. Suisun Bay meets water quality standards for all pollutants subject to the technology-based mass limits in this Order, and no increase in pollutant loading is likely. The new limits are therefore consistent with federal and State antidegradation policies.

Because antidegradation requirements are met, there will be no lowering of water quality; therefore, further analysis is unnecessary. Findings authorizing degradation are also unnecessary.

#### **Increased Production**

This Order includes technology-based mass loading limitations based on cracking refinery ELGs and an increased production rate of 165,000 bbls/day. Prior to granting approval for an increased discharge rate at Discharge point 001 that would correspond to a production increase, the Discharger must submit an Antidegradation Analysis in accordance with section VI.C.5.c of this Order that demonstrates consistency with the requirements of Resolution No. 68-16 and applicable federal antidegradation rules, policy, and guidance. Such an analysis shall demonstrate that the increased discharge rate would not degrade water quality.

### **D. Interim Effluent Limitation for Dioxin-TEQ**

As discussed in section IV.C.4.c.(5), the Discharger has shown the infeasibility of immediately complying with final limitations for dioxin-TEQ. The Discharger has demonstrated that a compliance schedule is justified based on source control and pollutant minimization efforts in the past and continued efforts in the present and future. This Order retains the interim effluent limitation from the previous permit for dioxin-TEQ.

#### **4. Compliance Schedule**

- a. As previously described, the Discharger submitted a Feasibility Study, and Regional Water Board staff confirmed its assertions.
- b. Maximum compliance schedules are reasonable for dioxin-TEQ because of the considerable uncertainty in determining effective measures (e.g., pollution prevention, treatment upgrades) that should be implemented to ensure compliance with final limits. In the Regional Water Board's view, it is appropriate to allow the Discharger sufficient time to first explore source control measures before requiring it to propose further actions, such as treatment plant upgrades, that are likely to be much more costly. This approach is supported by the Basin Plan (section 4.13), which states, "In general, it is often more economical to reduce overall pollutant loading into treatment systems than to install complex and expensive technology at the plant."

The previous permit contained an interim effluent limitation and a ten year compliance schedule for dioxin-TEQ that began on January 1, 2003. The term of the interim effluent limitation is continued by this Order and therefore remains in effect until January 1, 2013.

**E. Land Discharge Specifications**

Not Applicable.

**F. Reclamation Specifications**

This Order does not regulate the reclamation and use of treated wastewater, which is subject to the Department of Public Health regulations at Title 22 of the California Code of Regulations, Division 4, Chapter 3 (Water Recycling Criteria).

**V. RATIONALE FOR RECEIVING WATER LIMITATIONS**

Receiving water limitations are retained from the previous permit and reflect applicable water quality standards from Basin Plan Chapter 3.

**VI. RATIONALE FOR MONITORING AND REPORTING REQUIREMENTS**

The principal purposes of a monitoring program by a discharger are to:

- Document compliance with waste discharge requirements and prohibitions established by the Regional Water Board,
- Facilitate self-policing in the prevention and abatement of pollution arising from waste discharge,
- Develop or assist in the development of limitations, discharge prohibitions, national standards of performance, pretreatment and toxicity standards, and other standards, and prepare water and wastewater quality inventories.

The MRP is a standard requirement in almost all NPDES permits issued by the Regional Water Board, including this Order. It contains definitions of terms, specifies general sampling and analytical protocols, and sets out requirements for reporting spills, violations, and routine monitoring data in accordance with NPDES regulations, the CWC, and Regional Water Board policies. The MRP also defines the sampling stations and frequency, the pollutants to be monitored, and additional reporting requirements. Pollutants to be monitored include all parameters for which effluent limitations are specified. Monitoring for additional constituents, for which no effluent limitations are established, is also required to provide data for future completion of RPAs.

**A. Influent Monitoring**

Monitoring of influent to the wastewater treatment plant is not required.

**B. Effluent Monitoring**

The MRP retains most effluent monitoring requirements from the previous permit. Important changes in effluent monitoring requirements are summarized below.

*Discharge Point 001*

- Routine effluent monitoring for specific priority toxic pollutants is required only for those pollutants with effluent limitations. Priority toxic pollutants must be monitored two times per year and in accordance with the Regional Standard Provisions (Attachment G).

#### *Storm Water Discharge Points*

- Storm water monitoring frequency has been made more uniform for all storm water discharge points. Monitoring frequency at some storm water outfalls (Discharge Points 002 through 011, 016, and 017) has been increased to quarterly to provide better characterization of storm water discharges; monitoring frequency at other storm water outfalls (Discharge Points 003, 005, 006, and 017) has been decreased to quarterly from one time per storm event because monitoring during the term of the previous permit did not show exceedances of effluent limitations at these discharge points.
- The MRP does not require monitoring of storm water discharges at Discharge Points 012 through 015, which are outfalls to the City of Benicia sanitary sewer system. These discharges are not regulated by this Order, and are instead regulated by the City
- This Order requires better characterization of storm water that will no longer be treated by the refinery's wastewater treatment plant, but will be discharged at Discharge Points 003, 006, 009, and 010. The MRP requires monitoring of the priority toxic pollutants at two of these storm water outfalls per year. Monitoring locations must be rotated so that each of these outfalls will be monitored at least twice, once in the dry season and once in the wet season, in the expected five-year term of this Order.
- If effluent limitations for BOD, TSS, COD, chromium, and phenolic compounds become effective for discharges of storm water in accordance with section IV.C.2 of this Order, the MRP establishes a monitoring schedule for these pollutants.

### **C. Whole Effluent Toxicity Testing Requirements**

- 1. Acute Toxicity.** Weekly 96-hour bioassay testing is required to demonstrate compliance with the effluent limitation for acute toxicity.
- 2. Chronic Toxicity.** Chronic whole effluent toxicity testing is required quarterly in order to demonstrate compliance with effluent limitations for chronic toxicity.

### **D. Receiving Water Monitoring**

On April 15, 1992, the Regional Water Board adopted Resolution No. 92-043 directing the Executive Officer to implement the San Francisco Bay Regional Monitoring Program for Trace Substances (RMP). Subsequent to a public hearing and various meetings, Regional Water Board staff requested major permit holders in this Region, under authority of CWC section 13267, to report on the water quality of the estuary. These permit holders responded to this request by participating in a collaborative effort, through the San Francisco Estuary Institute. This effort has come to be known as the RMP. This Order specifies that the Discharger shall continue to participate in the RMP, which involves collection of data on pollutants and toxicity in water, sediment and biota of the estuary. In addition, the Order requires the Discharger to make

standard observations of Sulfur Springs Creek, Buffalo Wallow, and Beaver Creek once a month and once per rain event, as called for by the Regional Standard Provisions (Attachment G).

## **VII. RATIONALE FOR PROVISIONS**

### **A. Standard Provisions (Provision VI.A)**

Federal standard provisions, which apply to all NPDES discharges and must be included in every NPDES permit in accordance with 40 CFR 122.41 and 122.42, are provided in Attachment D of this Order. Regional standard provisions are also included as Attachment G.

### **B. Monitoring and Reporting Requirements (Provision VI.B)**

The Discharger is required to conduct monitoring to evaluate compliance with permit conditions. Monitoring requirements are in the MRP (Attachment E) and Regional Standard Provisions (Attachment G). This provision requires compliance with these documents and is based on 40 CFR 122.63 and CWC section 13267. The Regional Standard Provisions are standard requirements in almost all NPDES permits issued by the Regional Water Board, including this Order. They contain definitions of terms, specify general sampling and analytical protocols, and set out requirements for reporting of spills, violations, and routine monitoring data in accordance with NPDES regulations, the CWC, and Regional Water Board policies. The MRP contains a sampling program specific for the facility. It defines the sampling stations and frequency, the pollutants to be monitored, and additional reporting requirements. Pollutants to be monitored include all parameters for which effluent limitations are specified. Monitoring for additional constituents, for which no effluent limitations are established, is also required to provide data for future RPAs.

### **C. Special Provisions (Provision VI.C)**

#### **1. Reopener Provisions**

These provisions are based on 40 CFR 123 and allow future modification of this Order and its effluent limitations as necessary.

#### **2. Special Studies and Additional Monitoring**

- a. Effluent Characterization Study. This Order does not include effluent limitations for the selected constituents addressed in the Regional Standard Provisions (Attachment G) that do not demonstrate Reasonable Potential, but this provision requires the Discharger to continue monitoring for these pollutants as described in the Regional Standard Provisions and as specified in the MRP. If concentrations of these constituents increase significantly, the Discharger is required to investigate the sources of the increases and establish remedial measures, if the increases result in reasonable potential to cause or contribute to an excursion above water quality standards. This provision is based on the Basin Plan, the SIP, and CWC 13267.
- b. Ambient Background Receiving Water Study. This provision is based on the Basin Plan, the SIP, CWC 13267 and the Regional Standard Provisions (Attachment G). As indicated in this Order, this requirement may be met by participating in the collaborative BACWA study.

- c. Optional Mass Offset. This option is provided to encourage the Discharger to further implement aggressive reduction of mass loads of 303(d)-listed pollutants to Suisun Bay. If the Discharger wishes to pursue a mass offset program, it needs to submit a mass offset plan for reducing 303(d)-listed pollutants to Suisun Bay for Regional Water Board approval. The Regional Water Board may consider any proposed mass offset plan and amend this Order accordingly.
- d. Receiving Waters and Effluent Selenium Characterization Study. This Order requires a study to characterize current refinery discharges of selenium, to ensure that receiving water objectives are met, and to confirm that dilution credits for selenium are appropriate. Accordingly, Regional Water Board staff may use the data to evaluate dilution credits, characterize bioaccumulation potential and ecological risk, and to evaluate the quality of the receiving water with respect to selenium. The data also may be used to determine if exceedance frequency is correlated with seasonal or other environmental variations. If monitoring data show that selenium WQOs are exceeded in the receiving water, the permit may be reopened to include revised numeric effluent limits for selenium. As indicated in this Order, this requirement may be met by participating in a collaborative study. This requirements of this provision are thus reasonable and warranted, and are authorized by CWC 13267.
- e. Additional Storm Water Monitoring. This provision is included to prevent discharge of pollutants exceeding effluent limits in storm water discharges from the Tank Farm and Crude Oil Storage Area containment areas that are planned to be re-routed to stormwater outfalls 003, 006, 009, and 010. This provision is based on 40 CFR 122.44(i)

### **3. Best Management Practices and Pollution Minimization Program**

This provision is based on Basin Plan section 4.12.2 and SIP section 2.4.5.

### **4. Other Special Provisions**

#### **a. Cyanide Action Plan**

This provision is based on Basin Plan Table 3-3A, which contains site-specific objectives for cyanide for San Francisco Bay. The Basin Plan requires a cyanide action plan to ensure compliance with State and federal antidegradation policies when cyanide limits are based on the site-specific objectives.

#### **b. Copper Action Plan**

This Order requires the Discharger to implement monitoring and surveillance, pretreatment, source control, and pollution prevention for copper in accordance with the Basin Plan. Basin Plan Table 3-3A contains site-specific objectives for copper in all segments of San Francisco Bay. The Basin Plan also requires implementation of an action plan to ensure no degradation of water quality.

**c. Production Increase and Antidegradation Report**

The Discharger proposes to increase its crude throughput from 135,000 bbls/d to 165,000 bbls/d during the term of this Order. This increase of approximately 22 percent would result in approximately an 11 percent increase in the wastewater discharge rate.

The technology-based effluent limits established by this Order are based on the Effluent Limits Guidelines (ELGs) for cracking refineries. These effluent limits are production-based and therefore increase with increased crude throughput. The Discharger proposes to increase its crude throughput during the term of this Order. This provision ensures that the effluent limits corresponding to increased crude throughput will not become effective until adequate documentation is submitted demonstrating to the satisfaction of the Executive Officer that water quality will not be degraded, and production rates have increased to 165,000 bbls/d.

**d. Storm Water Pollution Prevention Plan and Annual Report**

This provision is based on Basin Plan section 4.8, statewide storm water requirements for industrial facilities, and applicable USEPA regulations. It is retained from the previous permit.

**e. Storm Water TSS Report and Best Management Practices**

The requirement for a separate report on elevated TSS levels and revised Best Management Practices to reduce and control TSS levels, and for implementation of the revised Best Management Practices, is included to address the historic exceedances of the TSS benchmark value of 100 mg/L contained in USEPA's NPDES Stormwater Multi-Sector General Permit for Industrial Activities (Federal Register Volume 65, Number 210, October 30, 2000). These exceedances are discussed in Fact Sheet section II.C.2.

**f. Dioxin-TEQ Compliance Schedule**

The State Water Board compliance schedule policy requires the following documentation to be submitted to the Regional Water Board to support a finding of infeasibility:

- Descriptions of diligent efforts the Discharger have made to quantify pollutant levels in the discharge, sources of the pollutant in the waste stream, and the results of those efforts.
- Descriptions of source control or pollutant minimization efforts currently under way or completed.
- A proposed schedule for additional or future source control measures, pollutant minimization, or waste treatment.
- A demonstration that the proposed schedule is as short as practicable.

The compliance schedule policy provides for a 10-year compliance schedule to implement measures to comply with new standards as of the effective date of those

standards. Additionally, the provision authorizes compliance schedules for new interpretations of other existing standards if the new interpretation results in more stringent limitations.

As previously described, the Discharger submitted an Infeasibility Report, and Regional Water Board staff confirmed its assertions. Based on this, a compliance schedule is appropriate for dioxin-TEQ because the Discharger has made good faith and reasonable efforts toward characterizing the sources. However, time to allow additional efforts is necessary to achieve compliance. The maximum allowable compliance schedule was granted to the Discharger for dioxin-TEQ in the previous permit because of the considerable uncertainty in determining effective measures (e.g., pollution prevention, treatment upgrades) that should be implemented to ensure compliance with final limits. It is appropriate to allow the Discharger sufficient time to first explore source control measures before requiring it to propose further actions, such as treatment plant upgrades, that are likely to be much more costly. This approach is supported by Basin Plan section 4.13, which states, "In general, it is often more economical to reduce overall pollutant loadings into the treatment systems than to install complex and expensive technology at the plant." Because of the ubiquitous nature of the sources of dioxin-TEQ, this provision allows the Discharger to address compliance with calculated WQBELs through other strategies such as mass offsets.

## **VIII. PUBLIC PARTICIPATION**

The Regional Water Board is considering the issuance of WDRs that will serve as a NPDES permit for the Valero Benicia Refinery. As a step in the WDRs adoption process, the Regional Water Board has developed tentative WDRs. The Regional Water Board encourages public participation in the WDR adoption process.

### **A. Notification of Interested Parties**

The Regional Water Board has notified the Dischargers and interested agencies and persons of its intent to prescribe WDRs for the discharge and has provided them with an opportunity to submit their written comments and recommendations. Notification was provided by publication in the Benicia Herald on September 14, 2009.

### **B. Written Comments**

Staff determinations are tentative. Interested persons are invited to submit written comments concerning these tentative WDRs. Comments must be submitted either in person or by mail to the Executive Office at the Regional Water Board at the address on the cover page of this Order, to the attention John Madigan.

To receive a full response from Regional Water Board staff and to be considered by the Regional Water Board, written comments should be received at the Regional Water Board offices by **5:00 p.m. on October 5, 2009.**

### **C. Public Hearing**

The Regional Water Board will hold a public hearing on the tentative WDRs during its regular Board meeting on the following date and time and at the following location:

Date: **November 18, 2009**  
Time: 9:00 am  
Location: Elihu Harris State Office Building  
1515 Clay Street, 1<sup>st</sup> Floor Auditorium  
Oakland, CA 94612

Contact: John Madigan, (510) 622-2405, email [JMadigan@waterboards.ca.gov](mailto:JMadigan@waterboards.ca.gov)

Interested persons are invited to attend. At the public hearing, the Regional Water Board will hear testimony, if any, pertinent to the discharge, WDRs, and permit. Oral testimony will be heard; however, for accuracy of the record, important testimony should be in writing.

Please be aware that dates and venues may change. The Regional Water Board's Web address is <http://www.waterboards.ca.gov/sanfranciscobay> where one can access the current agenda for changes in dates and locations.

### **D. Waste Discharge Requirements Petitions**

Any aggrieved person may petition the State Water Board to review the decision of the Regional Water Board regarding the WDRs. The petition must be submitted within 30 days of the Regional Water Board's action to the following address:

State Water Resources Control Board  
Office of Chief Counsel  
P.O. Box 100, 1001 I Street  
Sacramento, CA 95812-0100

### **E. Information and Copying**

The Report Of Waste Discharge, related documents, tentative effluent limitations and special provisions, comments received, and other information are on file and may be inspected at the address above at any time between 8:45 a.m. and 5:00 p.m., Monday through Friday. Copying of documents may be arranged by calling 510-622-2300.

### **F. Register of Interested Persons**

Any person interested in being placed on the mailing list for information regarding the WDRs and NPDES permit should contact the Regional Water Board, reference this facility, and provide a name, address, and phone number.

### **G. Additional Information**

Requests for additional information or questions regarding this order should be directed to John Madigan at 510-622-2405 (e-mail at [JMadigan@waterboards.ca.gov](mailto:JMadigan@waterboards.ca.gov)).



**ATTACHMENT F-1****Derivation of Technology-Based Effluent Limitations  
Valero Benicia Refinery*****References***

1. 40 CFR 419 Subpart B – Cracking Subcategory, *Effluent Limitation Guidelines and New Source Performance Standards for the Petroleum Refining Point Source Category* (2006)
2. *Development Document for Effluent Limitations Guidelines and New Source Performance Standards for the Petroleum Refining Point Source Category*, EPA/4401-82/014 (1982)
3. *Guide for the Application of Effluent Limitations Guidelines for the Petroleum Refining Industry*, USEPA Office of Water Regulations and Standards (1985)
4. Valero Energy Corporation, NPDES Application for Permit Renewal, NPDES Permit No. CA0005550 (May 31, 2007)
5. Refinery Production Data 2003 – 2007, from NPDES Application for Permit Renewal, Attachment 2C-IIIC – Basis for Reporting Production Rates

***Applicable Definitions***

*Process Waste Water* means any water, which, during manufacturing or processing, comes into direct contact with or results from the production or use of any raw material, intermediate product, finished product, byproduct, or waste product. [40 CFR 401.11(q)]

*Runoff* means the flow of storm water resulting from precipitation coming into contact with petroleum refinery property. [40 CFR 419.11(b)]

*Contaminated Runoff* means runoff that comes into contact with any raw material, intermediate product, finished product, by-product or waste product located on petroleum refinery property. [40 CFR 419.11(g)]

***Background***

Effluent Limitations Guidelines (ELGs) for the Cracking Subcategory of the Petroleum Refining Point Source Category at 40 CFR 419 Subpart B are based, in part, on a discharger's production rate. The Discharger's current maximum production rate is 135,000 barrels per day (bbls/d); however, during the term of this Order, production will increase to 165,000 bbls/d. Effluent limitations are calculated for both production figures.

*Process Wastewaters.* The ELGs include limitations for process wastewaters based on best practicable control technology currently available (BPT), best available technology economically achievable (BAT), and best conventional pollutant control technology (BCT). Specific BPT, BAT, and BCT effluent limitations that apply to the Discharger must be derived using methods described by the ELGs and take into account such factors as production rate, as well as refinery processes and configuration. The most stringent of BPT, BAT, and BCT limitations apply.

For derivation of BPT, BAT, and BCT limitations for process wastewaters, size factors and process factors are determined as follows.

Size Factor. At the crude processing rates of 135,000 and 165,000 bbls/d, the appropriate size factors, pursuant to the ELGs at 40 CFR 419.22(b)(1) for BPT, at 40 CFR 419.23(b)(1) for BAT, and at 40 CFR 419.24(b)(1) for BCT, for derivation of technology-based effluent limitations are as follows.

**Table F-1A. Size Factors**

Production Rate	Size Factor
135,000 bbls/d	1.35
165,000 bbls/d	1.41

Process Factor. The process configuration for each process is determined by summing the process feedstock rates for each crude, cracking and coking, lube, and asphalt process at the refinery. Each individual feedstock rate is multiplied by the capacity relative to the throughput, and a weight factor specific for each process, to derive a “process configuration,” which in turn is used to determine a “process factor” in accordance with the ELGs at 40 CFR 419.22(b)(2) for BPT, at 40 CFR 419.23(b)(2) for BAT, and at 40 CFR 419.24(b)(2) for BCT.

Processes considered in deriving the process factors are those processes within the crude and cracking and coking categories as reported by the Discharger, which correspond to the process groups listed within the *Guide for the Application of Effluent Limitations Guidelines for the Petroleum Refining Industry* (page 19). The Discharger does not include lube processes, and wastewaters from the facility’s asphalt plant are discharged to the City of Benicia sanitary sewer system, so these process groups are not considered in determining process factors.

Derivation of process configurations for production rates of 135,000 and 165,000 bbls/d are shown in the following table.

**Table F-1B. Process Configurations**

Production at 135,000 bbls/day				
Process	Process Feedstock Rate <sup>A</sup>	Process/ Feedstock Ratio	Weight Factor	Process Configuration
<b>Crude</b>				
Atm. Dist.	135	1		
Vac. Dist.	72.1	0.53		
Desalt.	135	1		
Total	342.1	2.5	1	2.53
<b>Cracking</b>				
FCC	77.0	0.57		
Fluid Coking	39.6	0.29		
Hydrocr.	40	0.30		
Total	156.6	1.2	6	6.96
<b>Lube</b>	---	---	13	---
<b>Asphalt</b>	---	---	12	---
<b>Total Refinery Configuration at 135,000 bbls/day</b>				<b>9.49</b>

<b>Production at 135,000 bbls/day</b>				
<b>Process</b>	<b>Process Feedstock Rate <sup>A</sup></b>	<b>Process/ Feedstock Ratio</b>	<b>Weight Factor</b>	<b>Process Configuration</b>
<b>Production at 165,000 bbls/day</b>				
<b>Crude</b>				
Atm. Dist.	165	1		
Vac. Dist.	72.1	0.44		
Desalt.	165	1		
Total	402.1	2.44	1	2.44
<b>Cracking</b>				
FCC	77	0.47		
Fluid Coking	39.6	0.24		
Hydrocr.	40	0.24		
Total	156.6	0.95	6	5.69
<b>Lube</b>	---	---	13	---
<b>Asphalt</b>	---	---	12	---
<b>Total Refinery Configuration at 165,000 bbls/day</b>				<b>8.13</b>

<sup>A</sup> 1,000 bbls/d

The following process factors are determined in accordance with 40 CFR 419.22(b)(2) for BPT, 40 CFR 419.232(b)(2) for BAT, 40 CFR 419.22(b)(2) for BCT.

**Table F-1C. Process Factors**

<b>Production Rate</b>	<b>Process Configuration</b>	<b>Process Factor</b>
135,000 bbls/d	9.49	1.82
165,000 bbls/d	8.13	1.53

To determine BAT limitations for total and hexavalent chromium and phenolic compounds in process wastewaters, the ELGs require consideration of effluent factors and refinery processes. BAT effluent factors are presented at 40 CFR 419.23(c)(1); the refinery processes considered are the crude, cracking and coking, and reforming and alkylation processes, which correspond to those identified within the *Guide for the Application of Effluent Limitations Guidelines for the Petroleum Refining Industry* (page 20).

Contaminated Runoff. The ELGs establish BPT, BAT, and BCT limitations for contaminated runoff, which apply to all storm water discharges, except storm water treated and discharged with process wastewaters through Discharge Point 001. ELGs establish effluent limitations for oil and grease and total organic carbon (TOC), and then, if limitations for oil and grease or TOC are exceeded, additional limitations for BOD, COD, TSS, phenolic compounds, pH, and hexavalent and total chromium, found at 40 CFR 419.22(e)(2) and 419.23(f)(2), become effective.

In general, BPT limitations are the most comprehensive and stringent of all applicable technology-based limitations for contaminated runoff and, therefore, are incorporated into this Order as additional effluent limitations for discharges of contaminated runoff where oil and grease or TOC limits are exceeded. The

following table summarizes the applicable technology-based effluent limitations, established by the ELGs, for contaminated runoff.

**Table F-1D. Contaminated Runoff Technology-Based Limitations**

Pollutant	Effluent Limitation <sup>A</sup>		
	Instantaneous Max (mg/L)	Max Daily (mg/L)	Avg Monthly (mg/L)
Oil and Grease	15 mg/L	---	---
TOC	110 mg/L	---	---
If either limitation for oil and grease or TOC, above, is exceeded, then the following limitations shall become effective			
BOD <sub>5</sub>	---	48	26
TSS	---	33	21
COD	---	360	180
Oil and Grease	---	15	8.0
Phenolic Compounds (4AAP)	---	0.35	0.17
Total Chromium	---	0.60	0.21
Hexavalent Chromium	---	0.062	0.028
pH	---	6.0 – 9.0	

<sup>A</sup> All effluent limitations reflect BPT requirements from 40 CFR 419 Subpart B, except limitations for total chromium, which reflect BAT requirements.

The Order establishes effluent limitations for oil and grease and TOC for all discharge points where contaminated runoff is discharged. Effluent limitations for BOD, TSS, COD, phenolics, and chromium will become effective immediately upon an exceedance of oil and grease or TOC for the outfall where the exceedance occurred. The effluent limit for pH listed in the table above is not imposed by this permit. The previous permit established a pH limit of 6.5 to 8.5, consistent with Basin Plan Table 4-2 for shallow-water discharges. This limit is retained by this Order to satisfy anti-backsliding requirements.

#### ***Determination of Process Wastewater Effluent Limitations***

BPT. The following table shows the derivation of process wastewater BPT limitations at production rates of 135,000 and 165,000 bbls/day.

**Table F-1E. BPT Limitations for Process Wastewaters**

	Preliminary Effluent Limitation Factor <sup>A</sup>		Size Factor	Process Factor	Feed Stock Rate	Effluent Limitation <sup>B</sup>	
	Max Daily	Avg Monthly				Max Daily	Avg Monthly
<b>Production at 135,000 bbls/d</b>							
BOD <sub>5</sub>	9.9	5.5	1.35	1.82	135	3300	1800
TSS	6.9	4.4	1.35	1.82	135	2300	1500
COD	74.0	38.4	1.35	1.82	135	25000	13000
Oil & Grease	3.0	1.6	1.35	1.82	135	995	530
Phenolics (4AAP)	0.074	0.036	1.35	1.82	135	25	12
Ammonia (as N)	6.6	3.0	1.35	1.82	135	2200	995
Sulfide	0.065	0.029	1.35	1.82	135	22	9.6
Total Chromium	0.15	0.088	1.35	1.82	135	50	29

	Preliminary Effluent Limitation Factor <sup>A</sup>		Size Factor	Process Factor	Feed Stock Rate	Effluent Limitation <sup>B</sup>	
	Max Daily	Avg Monthly				Max Daily	Avg Monthly
Hexavalent Chromium	0.012	0.0056	1.35	1.82	135	4.0	1.9
pH	---	---	---	---	---	6.0 – 9.0	
<b>Production at 165,000 bbls/d</b>							
BOD <sub>5</sub>	9.9	5.5	1.41	1.53	165	3500	2000
TSS	6.9	4.4	1.41	1.53	165	2500	1600
COD	74.0	38.4	1.41	1.53	165	26000	14000
Oil & Grease	3.0	1.6	1.41	1.53	165	1100	570
Phenolics (4AAP)	0.074	0.036	1.41	1.53	165	26	13
Ammonia (as N)	6.6	3.0	1.41	1.53	165	2300	1100
Sulfide	0.065	0.029	1.41	1.53	165	23	10
Total Chromium	0.15	0.088	1.41	1.53	165	53	31
Hexavalent Chromium	0.012	0.0056	1.41	1.53	165	4.3	2.0
pH	---	---	---	---	---	6.0 – 9.0	

<sup>A</sup> From 40 CFR 419.22(a) (pounds per 1000 bbls of feedstock)

<sup>B</sup> Pounds per day (lbs/d)

BAT. The following table shows the derivation of BAT limitations for process wastewaters at production rates of 135,000 and 165,000 bbls/d.

**Table F-1F. Process Wastewater BAT Limitations**

	Preliminary Effluent Limitation Factor <sup>A</sup>		Size Factor	Process Factor	Feed Stock Rate	Effluent Limitation <sup>B</sup>	
	Max Daily	Avg Monthly				Max Daily	Avg Monthly
<b>Production at 135,000 bbls/d</b>							
COD	74.0	38.4	1.35	1.82	135	25000	13000
Ammonia (as N)	6.6	3.0	1.35	1.82	135	2200	995
Sulfide	0.065	0.029	1.35	1.82	135	22	9.6
<b>Production at 165,000 bbls/d</b>							
COD	74.0	38.4	1.41	1.53	165	26000	14000
Ammonia (as N)	6.6	3.0	1.41	1.53	165	2300	1100
Sulfide	0.065	0.029	1.41	1.53	165	23	10

<sup>A</sup> From 40 CFR 419.23(a) (pounds per 1,000 bbls feedstock)

<sup>B</sup> Pounds per day (lbs/d)

BAT limitations for total and hexavalent chromium and phenolic compounds are based on feedstock rates. Figures used in calculations for this Order are shown in the following table.

**Table F-1G. Feedstock Rates for Determining BAT Limitations**

Refinery Throughput	Process Feedstock Rate (1,000 bbls/d)	
	135,000 bbls/d	165,000 bbls/d
<b>Crude</b>		
Atmospheric Pipestill	135	165
Vacuum Pipestill	72.1	72.1
Desalter	135	165
<b>Total</b>	<b>342.1</b>	<b>402.1</b>
<b>Cracking and Coking</b>		
Fluid Cat Cracking	77	77
Fluid Coking	39.6	39.6
Hydrocracking	40	40
Cat Feed Hydrofiner	36.8	36.8
Virgin Naptha Hydrofiner	30.4	30.4
Jet Hydrofiner	14.1	14.1
Diesel Hydrfiner	11.6	11.6
Heavy Cat Naptha Hydrofiner	18.6	18.6
Diene Hydrofiner	22.8	22.8
Light Cat Naptha Hydrofiner	22.6	22.6
Hardecut Saturation Unit	10.5	10.5
Ultra Low Sulfur Diesel	25	25
<b>Total</b>	<b>349</b>	<b>349</b>
<b>Lube</b>		
<b>Total</b>	<b>---</b>	<b>---</b>
<b>Reforming and Alkylation <sup>A</sup></b>		
Reforming	39.8	39.8
Alkylation	22.8	22.8
<b>Total</b>	<b>62.6</b>	<b>62.6</b>

<sup>A</sup> Although reported as a "Reforming and Alkylation" process by the Discharger, dimersol was not considered such a process for purposes of these calculations.

Based on the total feedstock rates shown above, derivation of BAT limitations for total and hexavalent chromium and phenolic compounds is shown in the following table.

**Table F-1H. Process Wastewater BAT Limitations (Chromium and Phenolics)**

Pollutant	Preliminary Effluent Limitations Factor <sup>A</sup>		Feedstock Rate	Effluent Limitations <sup>B</sup>	
	Max Daily	Avg Monthly		Max Daily	Avg Monthly
<b>Production at 135,000 bbls/d</b>					
<i>Phenolic Compounds</i>					
Crude	0.013	0.0030	342.1	3.7631	1.3684
Cracking and Coking	0.147	0.036	348.9	41.5191	14.3049
Asphalt	0.079	0.019	---	---	---
Lube	0.369	0.090	---	---	---
Reforming and Alkylation	0.132	0.032	62.6	8.2632	2.0032
<b>Limit (Sum)</b>	<b>---</b>	<b>---</b>	<b>---</b>	<b>64.0</b>	<b>15.6</b>

Pollutant	Preliminary Effluent Limitations Factor <sup>A</sup>		Feedstock Rate	Effluent Limitations <sup>B</sup>		
	Max Daily	Avg Monthly		Max Daily	Avg Monthly	
<b>Production at 135,000 bbls/d</b>						
<b>Total Chromium</b>						
Crude	0.011	0.004	342.1	3.7631	1.3684	
Cracking and Coking	0.119	0.041	348.9	41.531	14.309	
Asphalt	0.064	0.022	---	---	---	
Lube	0.299	0.104	---	---	---	
Reforming and Alkylation	0.107	0.037	62.6	6.6982	2.3162	
<b>Limit (Sum)</b>	---	---	---	<b>52.0</b>	<b>18.0</b>	
<b>Hexavalent Chromium</b>						
Crude	0.0007	0.0003	342.1	0.23947	0.10263	
Cracking and Coking	0.0076	0.0034	348.9	2.6516	1.18626	
Asphalt	0.0041	0.0019	---	---	---	
Lube	0.0192	0.0087	---	---	---	
Reforming and Alkylation	0.0069	0.0031	62.6	0.43194	0.19406	
<b>Limit (Sum)</b>	---	---	---	<b>3.32</b>	<b>1.48</b>	
<b>Production at 165,000 bbls/day</b>						
<b>Phenolic Compounds</b>						
Crude	0.013	0.003	402.1	5.2273	1.2063	
Cracking and Coking	0.147	0.036	348.9	51.2883	12.5604	
Asphalt	0.079	0.019	---	---	---	
Lube	0.369	0.090	---	---	---	
Reforming and Alkylation	0.132	0.032	62.6	8.2632	2.0032	
<b>Limit</b>	---	---	---	<b>65</b>	<b>16</b>	
<b>Total Chromium</b>						
Crude	0.011	0.004	402.1	4.4231	1.6084	
Cracking and Coking	0.119	0.041	348.9	41.519	14.309	
Asphalt	0.064	0.022	---	---	---	
Lube	0.299	0.104	---	---	---	
Reforming and Alkylation	0.107	0.037	62.6	6.6982	2.3162	
<b>Limit</b>	---	---	---	<b>53</b>	<b>18</b>	
<b>Hexavalent Chromium</b>						
Crude	0.0007	0.0003	402.1	0.28147	0.12063	
Cracking and Coking	0.0076	0.0034	348.9	2.6524	1.1866	
Asphalt	0.0041	0.0019	---	---	---	
Lube	0.0192	0.0087	---	---	---	
Reforming and Alkylation	0.0069	0.0031	62.6	0.43194	0.19406	
<b>Limit</b>	---	---	---	<b>3.4</b>	<b>1.5</b>	

<sup>A</sup> From 40 CFR 419.23(c), lbs per 1,000 barrels feedstock

<sup>B</sup> Pounds per day (lbs/d)

BCT. The following table shows the derivation of BCT limitations for process wastewaters at production rates of 135,000 and 165,000 bbls/d.

**Table F-1I. Process Wastewater BCT Limitations**

Pollutant	Preliminary Effluent Limitations Factor <sup>A</sup>		Size Factor	Process Factor	Feed Stock Rate	Final Effluent Limitations <sup>B</sup>	
	Max Daily	Avg Monthly				Max Daily	Avg Monthly
<b>Production at 135,000 bbls/d</b>							
BOD <sub>5</sub>	9.9	5.5	1.35	1.82	135	3300	1800
TSS	6.9	4.4	1.35	1.82	135	2300	1500
Oil & Grease	3.0	1.6	1.35	1.82	135	995	531
pH	---	---	---	---	---	6.0 – 9.0	
<b>Production at 165,000 bbls/day</b>							
BOD <sub>5</sub>	9.9	5.5	1.41	1.53	165	3500	2000
TSS	6.9	4.4	1.41	1.53	165	2500	1600
Oil & Grease	3.0	1.6	1.41	1.53	165	1100	570
pH	---	---	---	---	---	6.0 – 9.0	

<sup>A</sup> From 40 CFR 419.24(a), pounds per 1,000 barrels feedstock

<sup>B</sup> Pounds per day (lbs/d)

### ***Most Stringent Technology-Based Process Wastewater Effluent Limitations***

The following table presents the technology-based process wastewater effluent limitations that apply to the Discharger. The limitations are the most stringent of the BPT, BAT, and BCT limitations required by the ELGs and are expressed in units of lbs/day based on production rates of 135,000 and 165,000 bbls/d.

**Table F-1J. Summary of Technology-Based Process Wastewater Effluent Limitations**

Pollutant	Effluent Limitations <sup>A, B</sup>	
	Max Daily	Avg Monthly
<b>Production at 135,000 bbls/d</b>		
BOD <sub>5</sub>	3,300	1,800
TSS	2,300	1,500
COD	25,000	13,000
Oil & Grease	995	530
Phenolics (4AAP)	25	12
Ammonia (as N)	2200	995
Sulfide	22	9.6
Total Cr	50	18 <sup>C</sup>
Hex Cr	3.3 <sup>C</sup>	1.5 <sup>C</sup>
pH	6.0 – 9.0 pH units	
<b>Production at 165,000 bbls/d</b>		
BOD <sub>5</sub>	3500	2000
TSS	2500	1,600
COD	26,000	14,000
Oil & Grease	1,100	570



Pollutant	Effluent Limitations <sup>A, B</sup>	
	Max Daily	Avg Monthly
Phenolics (4AAP)	26	13
Ammonia (as N)	2,300	1,100
Sulfide	23	10
Total Chromium	53	18 <sup>C</sup>
Hexavalent Chromium	3.4 <sup>C</sup>	1.5 <sup>C</sup>
pH	6.0 – 9.0 pH units	

<sup>A</sup> Units are lbs/day

<sup>B</sup> All technology based limitations for process wastewaters are based on BPT unless otherwise noted.

<sup>C</sup> Based on BAT

### ***Determination of Effluent Limitations for Contaminated Runoff***

If contaminated storm water discharges exceed the oil and grease limit (15 mg/L) or the total organic carbon limit (110 mg/L), additional concentration-based limitations for BOD<sub>5</sub>, TSS, COD, phenolics, total chromium, hexavalent chromium, and pH become immediately effective. The effluent limitations for these pollutants are derived from the most stringent of the BCT, BAT, and BPT effluent concentration-based limitations provided in the ELGs. A table summarizing these additional effluent limitations is below.

**Table F-1L. Additional Storm Water Effluent Limitations**

Pollutant	Daily Maximum (mg/L)	30 Day Average (mg/L)
BOD <sub>5</sub>	48	26
TSS	33	21
COD	360	180
Oil and Grease	15	8.0
Phenolic Compounds	0.35	0.17
Total Chromium	0.60	0.21
Hexavalent Chromium	0.062	0.028
pH	6.0 – 9.0 at all times	

**CALIFORNIA REGIONAL WATER QUALITY CONTROL BOARD  
SAN FRANCISCO BAY REGION**

**ATTACHMENT G  
REGIONAL STANDARD PROVISIONS, AND MONITORING  
AND REPORTING REQUIREMENTS  
(SUPPLEMENT TO ATTACHMENT D)**

For

**NPDES WASTEWATER DISCHARGE PERMITS**

## Table of Contents

I.	STANDARD PROVISIONS - PERMIT COMPLIANCE .....	1
	A. Duty to Comply .....	1
	B. Need to Halt or Reduce Activity Not a Defense .....	1
	C. Duty to Mitigate .....	1
	1. Contingency Plan .....	1
	2. Spill Prevention Plan .....	2
	D. Proper Operation & Maintenance .....	2
	1. Operation and Maintenance (O&M) Manual .....	2
	2. Wastewater Facilities Status Report .....	3
	3. Proper Supervision and Operation of Publicly Owned Treatment Works (POTWs) .....	3
	E. Property Rights .....	3
	F. Inspection and Entry .....	3
	G. Bypass .....	3
	H. Upset .....	3
	I. Other .....	3
	J. Storm Water .....	3
	1. Storm Water Pollution Prevention Plan (SWPP Plan) .....	3
	2. Source Identification .....	4
	3. Storm Water Management Controls .....	5
	4. Annual Verification of SWPP Plan .....	6
	K. Biosolids Management .....	6
II.	STANDARD PROVISIONS – PERMIT ACTION .....	7
III.	STANDARD PROVISIONS – MONITORING .....	7
	A. Sampling and Analyses .....	7
	1. Use of Certified Laboratories .....	7
	2. Use of Appropriate Minimum Levels .....	8
	3. Frequency of Monitoring .....	9
	B. Biosolids Monitoring .....	9
	1. Biosolids Monitoring Frequency .....	9
	2. Biosolids Pollutants to Monitor .....	9
	C. Standard Observations .....	10
	1. Receiving Water Observations .....	11
	2. Wastewater Effluent Observations .....	11
	3. Beach and Shoreline Observations .....	12
	4. Land Retention or Disposal Area Observations .....	12
	5. Periphery of Waste Treatment and/or Disposal Facilities Observations .....	12
IV.	STANDARD PROVISIONS – RECORDS .....	13
	A. Records to be Maintained .....	13
	B. Records of monitoring information shall include .....	13
	1. Analytical Information .....	11
	2. Flow Monitoring Data .....	13
	3. Wastewater Treatment Process Solids .....	13

4. Disinfection Process .....	14
5. Treatment Process Bypasses .....	14
6. Treatment Facility Overflows .....	14
V. STANDARD PROVISIONS – REPORTING .....	15
A. Duty to Provide Information .....	15
B. Signatory and Certification Requirements .....	15
C. Monitoring Reports .....	15
1. Self-Monitoring Reports.....	15
D. Compliance Schedules .....	19
E. Twenty-Four Hour Reporting.....	19
1. Spill or Oil or Other Hazardous Material Reports .....	19
2. Unauthorized Discharges from Municipal Wastewater Treatment Plants .....	20
F. Planned Changes .....	22
G. Anticipated Noncompliance .....	22
H. Other Noncompliance.....	22
I. Other Information.....	22
VI. STANDARD PROVISIONS – ENFORCEMENT.....	22
VII. ADDITIONAL PROVISIONS – NOTIFICATION LEVELS.....	22
VIII. DEFINITIONS – This section is an addition to Standard Provisions (Attachment D) .....	24

**CALIFORNIA REGIONAL WATER QUALITY CONTROL BOARD  
SAN FRANCISCO BAY REGION**

**REGIONAL STANDARD PROVISIONS, AND MONITORING AND  
REPORTING REQUIREMENTS  
(SUPPLEMENT TO ATTACHMENT D)**

FOR

**NPDES WASTEWATER DISCHARGE PERMITS**

**APPLICABILITY**

This document applies to dischargers covered by a National Pollutant Discharge Elimination System (NPDES) permit. This document does not apply to Municipal Separate Storm Sewer System (MS4) NPDES permits.

The purpose of this document is to supplement the requirements of Attachment D, Standard Provisions. The requirements in this supplemental document are designed to ensure permit compliance through preventative planning, monitoring, recordkeeping, and reporting. In addition, this document requires proper characterization of issues as they arise, and timely and full responses to problems encountered. To provide clarity on which sections of Attachment D this document supplements, this document is arranged in the same format as Attachment D.

**I. STANDARD PROVISIONS - PERMIT COMPLIANCE**

**A. Duty to Comply – Not Supplemented**

**B. Need to Halt or Reduce Activity Not a Defense – Not Supplemented**

**C. Duty to Mitigate – This supplements I.C. of Standard Provisions (Attachment D)**

- 1. Contingency Plan** - The Discharger shall maintain a Contingency Plan as originally required by Regional Water Board Resolution 74-10 and as prudent in accordance with current municipal facility emergency planning. The Contingency Plan shall describe procedures to ensure that existing facilities remain in, or are rapidly returned to, operation in the event of a process failure or emergency incident, such as employee strike, strike by suppliers of chemicals or maintenance services, power outage, vandalism, earthquake, or fire. The Discharger may combine the Contingency Plan and Spill Prevention Plan into one document. Discharge in violation of the permit where the Discharger has failed to develop and implement a Contingency Plan as described below will be the basis for considering the discharge a willful and negligent violation of the permit pursuant to California Water Code section 13387. The Contingency Plan shall, at a minimum, contain the provisions of a. through g. below.

- a. Provision of personnel for continued operation and maintenance of sewerage facilities during employee strikes or strikes against contractors providing services.
  - b. Maintenance of adequate chemicals or other supplies and spare parts necessary for continued operations of sewerage facilities.
  - c. Provisions of emergency standby power.
  - d. Protection against vandalism.
  - e. Expeditious action to repair failures of, or damage to, equipment and sewer lines.
  - f. Report of spills and discharges of untreated or inadequately treated wastes, including measures taken to clean up the effects of such discharges.
  - g. Programs for maintenance, replacement, and surveillance of physical condition of equipment, facilities, and sewer lines.
- 2. Spill Prevention Plan** - The Discharger shall maintain a Spill Prevention Plan to prevent accidental discharges and minimize the effects of such events. The Spill Prevention Plan shall:
- a. Identify the possible sources of accidental discharge, untreated or partially treated waste bypass, and polluted drainage;
  - b. Evaluate the effectiveness of present facilities and procedures, and state when they became operational; and
  - c. Predict the effectiveness of the proposed facilities and procedures, and provide an implementation schedule containing interim and final dates when they will be constructed, implemented, or operational.

This Regional Water Board, after review of the Contingency and Spill Prevention Plans or their updated revisions, may establish conditions it deems necessary to control accidental discharges and to minimize the effects of such events. Such conditions may be incorporated as part of the permit upon notice to the Discharger.

**D. Proper Operation & Maintenance – This supplements I.D of Standard Provisions (Attachment D)**

- 1. Operation and Maintenance (O&M) Manual** - The Discharger shall maintain an O&M Manual to provide the plant and regulatory personnel with a source of information describing all equipment, recommended operational strategies, process control monitoring, and maintenance activities. To remain a useful and relevant document, the O&M Manual shall be kept updated to reflect significant changes in treatment facility equipment and operational practices. The O&M Manual shall be maintained in usable condition and be available for reference and use by all relevant personnel and Regional Water Board staff.

2. **Wastewater Facilities Status Report** - The Discharger shall regularly review, revise, or update, as necessary, its Wastewater Facilities Status Report. This report shall document how the Discharger operates and maintains its wastewater collection, treatment, and disposal facilities to ensure that all facilities are adequately staffed, supervised, financed, operated, maintained, repaired, and upgraded as necessary to provide adequate and reliable transport, treatment, and disposal of all wastewater from both existing and planned future wastewater sources under the Discharger's service responsibilities.
3. **Proper Supervision and Operation of Publicly Owned Treatment Works (POTWs)** - POTWs shall be supervised and operated by persons possessing certificates of appropriate grade pursuant to Division 4, Chapter 14, Title 23 of the California Code of Regulations.

**E. Property Rights – Not Supplemented**

**F. Inspection and Entry – Not Supplemented**

**G. Bypass – Not Supplemented**

**H. Upset – Not Supplemented**

**I. Other – This section is an addition to Standard Provisions (Attachment D)**

1. Neither the treatment nor the discharge of pollutants shall create pollution, contamination, or nuisance as defined by California Water Code section 13050.
2. Collection, treatment, storage, and disposal systems shall be operated in a manner that precludes public contact with wastewater, except in cases where excluding the public is infeasible, such as private property. If public contact with wastewater could reasonably occur on public property, warning signs shall be posted.
3. If the Discharger submits a timely and complete Report of Waste Discharge for permit reissuance, this permit continues in force and effect until a new permit is issued or the Regional Water Board rescinds the permit.

**J. Storm Water – This section is an addition to Standard Provisions (Attachment D)**

These provisions apply to facilities that do not direct all storm water flows from the facility to the wastewater treatment plant headworks.

**1. Storm Water Pollution Prevention Plan (SWPP Plan)**

The SWPP Plan shall be designed in accordance with good engineering practices and shall address the following objectives:

- a. To identify pollutant sources that may affect the quality of storm water discharges; and
- b. To identify, assign, and implement control measures and management practices to reduce pollutants in storm water discharges.

The SWPP Plan may be combined with the existing Spill Prevention Plan as required in accordance with section C.2. The SWPP Plan shall be retained on-site and made available upon request of a representative of the Regional Water Board.

## **2. Source Identification**

The SWPP Plan shall provide a description of potential sources that may be expected to add significant quantities of pollutants to storm water discharges, or may result in non-storm water discharges from the facility. The SWPP Plan shall include, at a minimum, the following items:

- a. A topographical map (or other acceptable map if a topographical map is unavailable), extending one-quarter mile beyond the property boundaries of the facility, showing the wastewater treatment facility process areas, surface water bodies (including springs and wells), and discharge point(s) where the facility's storm water discharges to a municipal storm drain system or other points of discharge to waters of the State. The requirements of this paragraph may be included in the site map required under the following paragraph if appropriate.
- b. A site map showing the following:
  - 1) Storm water conveyance, drainage, and discharge structures;
  - 2) An outline of the storm water drainage areas for each storm water discharge point;
  - 3) Paved areas and buildings;
  - 4) Areas of actual or potential pollutant contact with storm water or release to storm water, including but not limited to outdoor storage and process areas; material loading, unloading, and access areas; and waste treatment, storage, and disposal areas;
  - 5) Location of existing storm water structural control measures (i.e., berms, coverings, etc.);
  - 6) Surface water locations, including springs and wetlands; and
  - 7) Vehicle service areas.
- c. A narrative description of the following:
  - 1) Wastewater treatment process activity areas;
  - 2) Materials, equipment, and vehicle management practices employed to minimize contact of significant materials of concern with storm water discharges;
  - 3) Material storage, loading, unloading, and access areas;



- 4) Existing structural and non-structural control measures (if any) to reduce pollutants in storm water discharges; and
  - 5) Methods of on-site storage and disposal of significant materials.
- d. A list of pollutants that have a reasonable potential to be present in storm water discharges in significant quantities.

### **3. Storm Water Management Controls**

The SWPP Plan shall describe the storm water management controls appropriate for the facility and a time schedule for fully implementing such controls. The appropriateness and priorities of controls in the SWPP Plan shall reflect identified potential sources of pollutants. The description of storm water management controls to be implemented shall include, as appropriate:

- a. Storm water pollution prevention personnel

Identify specific individuals (and job titles) that are responsible for developing, implementing, and reviewing the SWPP Plan.

- b. Good housekeeping

Good housekeeping requires the maintenance of clean, orderly facility areas that discharge storm water. Material handling areas shall be inspected and cleaned to reduce the potential for pollutants to enter the storm drain conveyance system.

- c. Spill prevention and response

Identify areas where significant materials can spill into or otherwise enter storm water conveyance systems and their accompanying drainage points. Specific material handling procedures, storage requirements, and cleanup equipment and procedures shall be identified, as appropriate. The necessary equipment to implement a cleanup shall be available, and personnel shall be trained in proper response, containment, and cleanup of spills. Internal reporting procedures for spills of significant materials shall be established.

- d. Source control

Source controls include, for example, elimination or reduction of the use of toxic pollutants, covering of pollutant source areas, sweeping of paved areas, containment of potential pollutants, labeling of all storm drain inlets with “No Dumping” signs, isolation or separation of industrial and non-industrial pollutant sources so that runoff from these areas does not mix, etc.

- e. Storm water management practices

Storm water management practices are practices other than those that control the sources of pollutants. Such practices include treatment or conveyance structures, such as drop inlets, channels, retention and detention basins, treatment vaults, infiltration galleries, filters, oil/water separators, etc. Based on assessment of the

potential of various sources to contribute pollutants to storm water discharges in significant quantities, additional storm water management practices to remove pollutants from storm water discharges shall be implemented and design criteria shall be described.

f. Sediment and erosion control

Measures to minimize erosion around the storm water drainage and discharge points, such as riprap, revegetation, slope stabilization, etc., shall be described.

g. Employee training

Employee training programs shall inform all personnel responsible for implementing the SWPP Plan. Training shall address spill response, good housekeeping, and material management practices. New employee and refresher training schedules shall be identified.

h. Inspections

All inspections shall be done by trained personnel. Material handling areas shall be inspected for evidence of, or the potential for, pollutants entering storm water discharges. A tracking or follow up procedure shall be used to ensure appropriate response has been taken in response to an inspection. Inspections and maintenance activities shall be documented and recorded. Inspection records shall be retained for five years.

i. Records

A tracking and follow-up procedure shall be described to ensure that adequate response and corrective actions have been taken in response to inspections.

**4. Annual Verification of SWPP Plan**

An annual facility inspection shall be conducted to verify that all elements of the SWPP Plan are accurate and up-to-date. The results of this review shall be reported in the Annual Report to the Regional Water Board described in section V.C.f.

**K. Biosolids Management – This section is an addition to Standard Provisions (Attachment D)**

Biosolids must meet the following requirements prior to land application. The Discharger must either demonstrate compliance or, if it sends the biosolids to another party for further treatment or distribution, must give the recipient the information necessary to ensure compliance.

1. Exceptional quality biosolids meet the pollutant concentration limits in Table III of 40 CFR Part 503.13, Class A pathogen limits, and one of the vector attraction reduction requirements in 503.33(b)(1)-(b)(8). Such biosolids do not have to be tracked further for compliance with general requirements (503.12) and management practices (503.14).

2. Biosolids used for agricultural land, forest, or reclamation shall meet the pollutant limits in Table I (ceiling concentrations) and Table II or Table III (cumulative loadings or pollutant concentration limits) of 503.13. They shall also meet the general requirements (503.12) and management practices (503.14) (if not exceptional quality biosolids) for Class A or Class B pathogen levels with associated access restrictions (503.32) and one of the 10 vector attraction reduction requirements in 503.33(b)(1)-(b)(10).
3. Biosolids used for lawn or home gardens must meet exceptional quality biosolids limits.
4. Biosolids sold or given away in a bag or other container must meet the pollutant limits in either Table III or Table IV (pollutant concentration limits or annual pollutant loading rate limits) of 503.13. If Table IV is used, a label or information sheet must be attached to the biosolids packing that explains Table IV (see 503.14). The biosolids must also meet the Class A pathogen limits and one of the vector attraction reduction requirements in 503.33(b)(1)-(b)(8).

## **II. STANDARD PROVISIONS – PERMIT ACTION – Not Supplemented**

### **III. STANDARD PROVISIONS – MONITORING**

#### **A. Sampling and Analyses – This section is a supplement to III.A and III.B of Standard Provisions (Attachment D)**

##### **1. Use of Certified Laboratories**

Water and waste analyses shall be performed by a laboratory certified for these analyses in accordance with California Water Code section 13176.

##### **2. Use of Appropriate Minimum Levels**

Table C lists the suggested analytical methods for the 126 priority pollutants and other toxic pollutants that should be used, unless a particular method or minimum level (ML) is required in the MRP.

For priority pollutant monitoring, when there is more than one ML value for a given substance, the Discharger may select any one of those cited analytical methods for compliance determination provided the ML is below the effluent limitation and the water quality objective. If no ML value is below the effluent limitation and water quality objective, then the Regional Water Board will assign the lowest ML value indicated in Table C, and its associated analytical method for inclusion in the MRP. For effluent monitoring, this alternate method shall also be USEPA-approved (such as the 1600 series) or one of those listed in Table C. All monitoring instruments and equipment shall be properly calibrated and maintained to ensure accuracy of measurements.

##### **3 Frequency of Monitoring**

The minimum schedule of sampling analysis is specified in the MRP portion of the permit.

**a. Timing of Sample Collection**

- i. The Discharger shall collect samples of influent on varying days selected at random and shall not include any plant recirculation or other sidestream wastes, unless otherwise stipulated by the MRP.
- ii. The Discharger shall collect samples of effluent on days coincident with influent sampling unless otherwise stipulated by the MRP or the Executive Officer. The Executive Officer may approve an alternative sampling plan if it is demonstrated to be representative of plant discharge flow and in compliance with all other permit requirements.
- iii. The Discharger shall collect grab samples of effluent during periods of day-time maximum peak effluent flows (or peak flows through secondary treatment units for facilities that recycle effluent flows).
- iv. Effluent sampling for conventional pollutants shall occur on at least one day of any multiple-day bioassay test the MRP requires. During the course of the test, on at least one day, the Discharger shall collect and retain samples of the discharge. In the event a bioassay test does not comply with permits limits, the Discharger shall analyze these retained samples for pollutants that could be toxic to aquatic life and for which it has effluent limits.
  - 1) The Discharger shall perform bioassay tests on final effluent samples; when chlorine is used for disinfection, bioassay tests shall be performed on effluent after chlorination-dechlorination; and
  - 2) The Discharger shall analyze for total ammonia nitrogen and calculate the amount of un-ionized ammonia whenever test results fail to meet the percent survival specified in the permit.

**b. Conditions Triggering Accelerated Monitoring**

- i. If the results from two consecutive samples of a constituent monitored in a 30-day period exceed the monthly average limit for any parameter (or if the required sampling frequency is once per month and the monthly sample exceeds the monthly average limit), the Discharger shall, within 24 hours after the results are received, increase its sampling frequency to daily until the results from the additional sampling shows that the parameter is in compliance with the monthly average limit.
- ii. If any maximum daily limit is exceeded, the Discharger shall increase its sampling frequency to daily within 24 hours after the results are received that indicate the exceedance of the maximum daily limit until two samples collected on consecutive days show compliance with the maximum daily limit.
- iii. If final or intermediate results of an acute bioassay test indicate a violation or threatened violation (e.g., the percentage of surviving test organisms of

any single acute bioassay test is less than 70 percent), the Discharger shall initiate a new test as soon as practical, and the Discharger shall investigate the cause of the mortalities and report its findings in the next self-monitoring report (SMR).

- iv. The Discharger shall calibrate chlorine residual analyzers against grab samples as frequently as necessary to maintain accurate control and reliable operation. If an effluent violation is detected, the Discharger shall collect grab samples at least every 30 minutes until compliance with the limit is achieved, unless the Discharger monitors chlorine residual continuously. In such cases, the Discharger shall continue to conduct continuous monitoring as required by its permit.
- v. When any type of bypass occurs, the Discharger shall collect samples on a daily basis for all constituents at affected discharge points that have effluent limits for the duration of the bypass, unless otherwise stipulated by the MRP.

**c. Storm Water Monitoring**

The requirements of this section only apply to facilities that are not covered by an NPDES permit for storm water discharges and where not all site storm drainage from process areas (i.e., areas of the treatment facility where chemicals or wastewater could come in contact with storm water) is directed to the headworks. For storm water not directed to the headworks during the wet season (October 1 to April 30), the Discharger shall:

- i. Conduct visual observations of the storm water discharge locations during daylight hours at least once per month during a storm event that produces significant storm water discharge to observe the presence of floating and suspended materials, oil and grease, discoloration, turbidity, and odor, etc.
- ii. Measure (or estimate) the total volume of storm water discharge, collect grab samples of storm water discharge from at least two storm events that produce significant storm water discharge, and analyze the samples for oil and grease, pH, TSS, and specific conductance.

The grab samples shall be taken during the first 30 minutes of the discharge. If collection of the grab samples during the first 30 minutes is impracticable, grab samples may be taken during the first hour of the discharge, and the Discharger shall explain in the Annual Report why the grab sample(s) could not be taken in the first 30 minutes.

- iii. Testing for the presence of non-storm water discharges shall be conducted no less than twice during the dry season (May 1 to September 30) at all storm water discharge locations. Tests may include visual observations of flows, stains, sludges, odors, and other abnormal conditions; dye tests; TV line surveys; or analysis and validation of accurate piping schematics. Records shall be maintained describing the method used, date of testing, locations observed, and test results.

- iv. Samples shall be collected from all locations where storm water is discharged. Samples shall represent the quality and quantity of storm water discharged from the facility. If a facility discharges storm water at multiple locations, the Discharger may sample a reduced number of locations if it establishes and documents through the monitoring program that storm water discharges from different locations are substantially identical.
- v. Records of all storm water monitoring information and copies of all reports required by the permit shall be retained for a period of at least three years from the date of sample, observation, or report.

**d. Receiving Water Monitoring**

The requirements of this section only apply when the MRP requires receiving water sampling.

- i. Receiving water samples shall be collected on days coincident with effluent sampling for conventional pollutants.
- ii. Receiving water samples shall be collected at each station on each sampling day during the period within one hour following low slack water. Where sampling during lower slack water is impractical, sampling shall be performed during higher slack water. Samples shall be collected within the discharge plume and down current of the discharge point so as to be representative, unless otherwise stipulated in the MRP.
- iii. Samples shall be collected within one foot of the surface of the receiving water, unless otherwise stipulated in the MRP.

**B. Biosolids Monitoring – This section supplements III.B of Standard Provisions (Attachment D)**

When biosolids are sent to a landfill, sent to a surface disposal site, or applied to land as a soil amendment, they must be monitored as follows:

**1. Biosolids Monitoring Frequency**

Biosolids disposal must be monitored at the following frequency:

<b>Metric tons biosolids/365 days</b>	<b>Frequency</b>
0-290	Once per year
290-1500	Quarterly
1500-15,000	Six times per year
Over 15,000	Once per month
(Metric tons are on a dry weight basis)	

## 2. Biosolids Pollutants to Monitor

Biosolids shall be monitored for the following constituents:

Land Application: arsenic, cadmium, chromium, copper, mercury, molybdenum, nickel, lead, selenium, and zinc

Municipal Landfill: Paint filter test (pursuant to 40 CFR 258)

Biosolids-only Landfill or Surface Disposal Site (if no liner and leachate system): arsenic, chromium, and nickel

## C. Standard Observations – This section is an addition to III of Standard Provisions (Attachment D)

### 1. Receiving Water Observations

The requirements of this section only apply when the MRP requires standard observations of the receiving water. Standard observations shall include the following:

- a. *Floating and suspended materials* (e.g., oil, grease, algae, and other macroscopic particulate matter): presence or absence, source, and size of affected area.
- b. *Discoloration and turbidity*: description of color, source, and size of affected area.
- c. *Odor*: presence or absence, characterization, source, distance of travel, and wind direction.
- d. *Beneficial water use*: presence of water-associated waterfowl or wildlife, fisherpeople, and other recreational activities in the vicinity of each sampling station.
- e. *Hydrographic condition*: time and height of corrected high and low tides (corrected to nearest National Oceanic and Atmospheric Administration location for the sampling date and time of sample collection).
- f. *Weather conditions*:
  - 1) Air temperature; and
  - 2) Total precipitation during the five days prior to observation.

### 2. Wastewater Effluent Observations

The requirements of this section only apply when the MRP requires wastewater effluent standard observations. Standard observations shall include the following:

- a. *Floating and suspended material of wastewater origin* (e.g., oil, grease, algae, and other macroscopic particulate matter): presence or absence.
- b. *Odor*: presence or absence, characterization, source, distance of travel, and wind direction.

### **3. Beach and Shoreline Observations**

The requirements of this section only apply when the MRP requires beach and shoreline standard observations. Standard observations shall include the following:

- a. *Material of wastewater origin*: presence or absence, description of material, estimated size of affected area, and source.
- b. *Beneficial use*: estimate number of people participating in recreational water contact, non-water contact, or fishing activities.

### **4. Land Retention or Disposal Area Observations**

The requirements of this section only apply to facilities with on-site surface impoundments or disposal areas that are in use. This section applies to both liquid and solid wastes, whether confined or unconfined. The Discharger shall conduct the following for each impoundment:

- a. Determine the amount of freeboard at the lowest point of dikes confining liquid wastes.
- b. Report evidence of leaching liquid from area of confinement and estimated size of affected area. Show affected area on a sketch and volume of flow (e.g., gallons per minute [gpm]).
- c. Regarding odor, describe presence or absence, characterization, source, distance of travel, and wind direction.
- d. Estimate number of waterfowl and other water-associated birds in the disposal area and vicinity.

### **5. Periphery of Waste Treatment or Disposal Facilities Observations**

The requirements of this section only apply when the MRP specifies periphery standard observations. Standard observations shall include the following:

- a. *Odor*: presence or absence, characterization, source, and distance of travel.
- b. *Weather conditions*: wind direction and estimated velocity.



## **IV. STANDARD PROVISIONS – RECORDS**

### **A. Records to be Maintained – This supplements IV.A of Standard Provisions (Attachment D)**

The Discharger shall maintain records in a manner and at a location (e.g., wastewater treatment plant or Discharger offices) such that the records are accessible to Regional Water Board staff. The minimum period of retention specified in section IV, Records, of the Federal Standard Provisions shall be extended during the course of any unresolved litigation regarding the subject discharge, or when requested by the Regional Water Board or Regional Administrator of USEPA, Region IX.

A copy of the permit shall be maintained at the discharge facility and be available at all times to operating personnel.

### **B. Records of monitoring information shall include – This supplements IV.B of Standard Provision (Attachment D)**

#### **1. Analytical Information**

Records shall include analytical method detection limits, minimum levels, reporting levels, and related quantification parameters.

#### **2. Flow Monitoring Data**

For all required flow monitoring (e.g., influent and effluent flows), the additional records shall include the following, unless otherwise stipulated by the MRP:

- a. Total volume for each day; and
- b. Maximum, minimum, and average daily flows for each calendar month.

#### **3. Wastewater Treatment Process Solids**

- a. For each treatment unit process that involves solids removal from the wastewater stream, records shall include the following:
  - 1) Total volume or mass of solids removed from each unit (e.g., grit, skimmings, undigested biosolids) for each calendar month or other time period as appropriate, but not to exceed annually; and
  - 2) Final disposition of such solids (e.g., landfill, other subsequent treatment unit).
- b. For final dewatered biosolids from the treatment plant as a whole, records shall include the following:
  - 1) Total volume or mass of dewatered biosolids for each calendar month;
  - 2) Solids content of the dewatered biosolids; and

- 3) Final disposition of dewatered biosolids (disposal location and disposal method).

#### **4. Disinfection Process**

For the disinfection process, these additional records shall be maintained documenting process operation and performance:

- a. For bacteriological analyses:
  - 1) Wastewater flow rate at the time of sample collection; and
  - 2) Required statistical parameters for cumulative bacterial values (e.g., moving median or geometric mean for the number of samples or sampling period identified in this Order).
- b. For the chlorination process, when chlorine is used for disinfection, at least daily average values for the following:
  - 1) Chlorine residual of treated wastewater as it enters the contact basin (mg/L);
  - 2) Chlorine dosage (kg/day); and
  - 3) Dechlorination chemical dosage (kg/day).

#### **5. Treatment Process Bypasses**

A chronological log of all treatment process bypasses, including wet weather blending, shall include the following:

- a. Identification of the treatment process bypassed;
- b. Dates and times of bypass beginning and end;
- c. Total bypass duration;
- d. Estimated total bypass volume; and
- e. Description of, or reference to other reports describing, the bypass event, the cause, the corrective actions taken (except for wet weather blending that is in compliance with permit conditions), and any additional monitoring conducted.

#### **6. Treatment Facility Overflows**

This section applies to records for overflows at the treatment facility. This includes the headworks and all units and appurtenances downstream. The Discharger shall retain a chronological log of overflows at the treatment facility and records supporting the information provided in section V.E.2.

**C. Claims of Confidentiality – Not Supplemented**

**V. STANDARD PROVISIONS – REPORTING**

**A. Duty to Provide Information – Not Supplemented**

**B. Signatory and Certification Requirements – Not Supplemented**

**C. Monitoring Reports – This section supplements V.C of Standard Provisions (Attachment D)**

**1. Self-Monitoring Reports**

For each reporting period established in the MRP, the Discharger shall submit an SMR to the Regional Water Board in accordance with the requirements listed in this document and at the frequency the MRP specifies. The purpose of the SMR is to document treatment performance, effluent quality, and compliance with the waste discharge requirements of this Order.

a. Transmittal letter

Each SMR shall be submitted with a transmittal letter. This letter shall include the following:

- 1) Identification of all violations of effluent limits or other waste discharge requirements found during the reporting period;
- 2) Details regarding violations: parameters, magnitude, test results, frequency, and dates;
- 3) Causes of violations;
- 4) Discussion of corrective actions taken or planned to resolve violations and prevent recurrences, and dates or time schedule of action implementation (if previous reports have been submitted that address corrective actions, reference to the earlier reports is satisfactory);
- 5) Data invalidation (Data should not be submitted in an SMR if it does not meet quality assurance/quality control standards. However, if the Discharger wishes to invalidate any measurement after it was submitted in an SMR, a letter shall identify the measurement suspected to be invalid and state the Discharger's intent to submit, within 60 days, a formal request to invalidate the measurement. This request shall include the original measurement in question, the reason for invalidating the measurement, all relevant documentation that supports invalidation [e.g., laboratory sheet, log entry, test results, etc.], and discussion of the corrective actions taken or planned [with a time schedule for completion] to prevent recurrence of the sampling or measurement problem.);

- 6) If the Discharger blends, the letter shall describe the duration of blending events and certify whether blended effluent was in compliance with the conditions for blending; and
- 7) Signature (The transmittal letter shall be signed according to section V.B of this Order, Attachment D – Standard Provisions.).

b. Compliance evaluation summary

Each report shall include a compliance evaluation summary. This summary shall include each parameter for which the permit specifies effluent limits, the number of samples taken during the monitoring period, and the number of samples that exceed applicable effluent limits.

c. Results of analyses and observations

- 1) Tabulations of all required analyses and observations, including parameter, date, time, sample station, type of sample, test result, method detection limit, method minimum level, and method reporting level, if applicable, signed by the laboratory director or other responsible official.
- 2) When determining compliance with an average monthly effluent limitation and more than one sample result is available in a month, the Discharger shall compute the arithmetic mean unless the data set contains one or more reported determinations of detected but not quantified (DNQ) or nondetect (ND). In those cases, the Discharger shall compute the median in place of the arithmetic mean in accordance with the following procedure:
  - i. The data set shall be ranked from low to high, reported ND determinations lowest, DNQ determinations next, followed by quantified values (if any). The order of the individual ND or DNQ determinations is unimportant.
  - ii. The median value of the data set shall be determined. If the data set has an odd number of data points, then the median is the middle value. If the data set has an even number of data points, then the median is the average of the two values around the middle unless one or both of the points are ND or DNQ, in which case the median value shall be the lower of the two data points where DNQ is lower than a value and ND is lower than DNQ.

If a sample result, or the arithmetic mean or median of multiple sample results, is below the reporting limit, and there is evidence that the priority pollutant is present in the effluent above an effluent limitation and the Discharger conducts a Pollutant Minimization Program, the Discharger shall not be deemed out of compliance.

- 3) Dioxin-TEQ Reporting: The Discharger shall report for each dioxin and furan congener the analytical results of effluent monitoring, including the

quantifiable limit (reporting level), and the method detection limit, and the measured concentration. Estimated concentrations shall be reported for individual congeners, but shall be set equal to zero in determining the dioxin-TEQ value. The Discharger shall multiply each measured or estimated congener concentration by its respective toxicity equivalency factor (TEF) shown in Table A and report the sum of these values.

**Table A: Toxic Equivalency Factors for 2,3,7,8-TCDD Equivalents**

<b>Congener</b>	<b>TEF</b>
2,3,7,8-TetraCDD	1
1,2,3,7,8-PentaCDD	1.0
1,2,3,4,7,8-HexaCDD	0.1
1,2,3,6,7,8-HexaCDD	0.1
1,2,3,7,8,9-HexaCDD	0.1
1,2,3,4,6,7,8-HeptaCDD	0.01
OctaCDD	0.0001
2,3,7,8-TetraCDF	0.1
1,2,3,7,8-PentaCDF	0.05
2,3,4,7,8-PentaCDF	0.5
1,2,3,4,7,8-HexaCDF	0.1
1,2,3,6,7,8-HexaCDF	0.1
1,2,3,7,8,9-HexaCDF	0.1
2,3,4,6,7,8-HexaCDF	0.1
1,2,3,4,6,7,8-HeptaCDF	0.01
1,2,3,4,7,8,9-HeptaCDF	0.01
OctaCDF	0.0001

d. Data reporting for results not yet available

The Discharger shall make all reasonable efforts to obtain analytical data for required parameter sampling in a timely manner. Certain analyses require additional time to complete analytical processes and report results. For cases where required monitoring parameters require additional time to complete analytical processes and reports, and results are not available in time to be included in the SMR for the subject monitoring period, the Discharger shall describe such circumstances in the SMR and include the data for these parameters and relevant discussions of any observed exceedances in the next SMR due after the results are available.

e. Flow data

The Discharger shall provide flow data tabulation pursuant to section IV.B.2.

f. Annual self-monitoring report requirements

By the date specified in the MRP, the Discharger shall submit an annual report to the Regional Water Board covering the previous calendar year. The report shall contain the following:

- 1) Annual compliance summary table of treatment plant performance, including documentation of any blending events;
- 2) Comprehensive discussion of treatment plant performance and compliance with the permit (This discussion shall include any corrective actions taken or planned, such as changes to facility equipment or operation practices that may be needed to achieve compliance, and any other actions taken or planned that are intended to improve performance and reliability of the Discharger's wastewater collection, treatment, or disposal practices.);
- 3) Both tabular and graphical summaries of the monitoring data for the previous year if parameters are monitored at a frequency of monthly or greater;
- 4) List of approved analyses, including the following:
  - (i) List of analyses for which the Discharger is certified;
  - (ii) List of analyses performed for the Discharger by a separate certified laboratory and copies of reports signed by the laboratory director of that laboratory shall not be submitted but retained on-site;
  - (iii) List of "waived" analyses, as approved;
- 5) Plan view drawing or map showing the Discharger's facility, flow routing, and sampling and observation station locations;
- 6) Results of annual facility inspection to verify that all elements of the SWPP Plan are accurate and up to date (only required if the Discharger does not route all storm water to the headworks of its wastewater treatment plant); and
- 7) Results of facility report reviews (The Discharger shall regularly review, revise, and update, as necessary, the O&M Manual, the Contingency Plan, the Spill Prevention Plan, and Wastewater Facilities Status Report so that these documents remain useful and relevant to current practices. At a minimum, reviews shall be conducted annually. The Discharger shall include, in each Annual Report, a description or summary of review and evaluation procedures, recommended or planned actions, and an estimated time schedule for implementing these actions. The Discharger shall complete changes to these documents to ensure they are up-to-date.).

g. Report submittal

The Discharger shall submit SMRs to:

California Regional Water Quality Control Board  
San Francisco Bay Region

1515 Clay Street, Suite 1400  
Oakland, CA 94612  
Attn: NPDES Wastewater Division

h. Reporting data in electronic format

The Discharger has the option to submit all monitoring results in an electronic reporting format approved by the Executive Officer. If the Discharger chooses to submit SMRs electronically, the following shall apply:

- 1) *Reporting Method*: The Discharger shall submit SMRs electronically via a process approved by the Executive Officer (see, for example, the letter dated December 17, 1999, "Official Implementation of Electronic Reporting System [ERS]" and the progress report letter dated December 17, 2000).
- 2) *Monthly or Quarterly Reporting Requirements*: For each reporting period (monthly or quarterly as specified in the MRP), the Discharger shall submit an electronic SMR to the Regional Water Board in accordance with the provisions of section V.C.1.a-e, except for requirements under section V.C.1.c(1) where ERS does not have fields for dischargers to input certain information (e.g., sample time). However, until USEPA approves the electronic signature or other signature technologies, Dischargers that use ERS shall submit a hard copy of the original transmittal letter, an ERS printout of the data sheet, and a violation report (a receipt of the electronic transmittal shall be retained by the Discharger). This electronic SMR submittal suffices for the signed tabulations specified under section V.C.1.c(1).
- 3) *Annual Reporting Requirements*: Dischargers who have submitted data using the ERS for at least one calendar year are exempt from submitting the portion of the annual report required under section V.C.1.f(1) and (3).

**D. Compliance Schedules – Not supplemented**

**E. Twenty-Four Hour Reporting – This section supplements V.E of Standard Provision (Attachment D)**

**1. Spill of Oil or Other Hazardous Material Reports**

- a. Within 24 hours of becoming aware of a spill of oil or other hazardous material that is not contained on-site and completely cleaned up, the Discharger shall report by telephone to the Regional Water Board at (510) 622-2369.
- b. The Discharger shall also report such spills to the State Office of Emergency Services [telephone (800) 852-7550] only when the spills are in accordance with applicable reporting quantities for hazardous materials.
- c. The Discharger shall submit a written report to the Regional Water Board within five working days following telephone notification unless

directed otherwise by Regional Water Board staff. A report submitted electronically is acceptable. The written report shall include the following:

- 1) Date and time of spill, and duration if known;
- 2) Location of spill (street address or description of location);
- 3) Nature of material spilled;
- 4) Quantity of material involved;
- 5) Receiving water body affected, if any;
- 6) Cause of spill;
- 7) Estimated size of affected area;
- 8) Observed impacts to receiving waters (e.g., oil sheen, fish kill, water discoloration);
- 9) Corrective actions taken to contain, minimize, or clean up the spill;
- 10) Future corrective actions planned to be taken to prevent recurrence, and schedule of implementation; and
- 11) Persons or agencies notified.

## **2. Unauthorized Discharges from Municipal Wastewater Treatment Plants<sup>1</sup>**

The following requirements apply to municipal wastewater treatment plants that experience an unauthorized discharge at their treatment facilities and are consistent with and supercede requirements imposed on the Discharger by the Executive Officer by letter of May 1, 2008, issued pursuant to California Water Code section 13383.

### **a. Two (2)-Hour Notification**

For any unauthorized discharges that result in a discharge to a drainage channel or a surface water, the Discharger shall, as soon as possible, but not later than two (2) hours after becoming aware of the discharge, notify the State Office of Emergency Services (telephone 800-852-7550), the local health officers or directors of environmental health with jurisdiction over the affected water bodies, and the Regional Water Board. The notification to the Regional Water Board shall be via the Regional Water Board's online reporting system at [www.wbers.net](http://www.wbers.net), and shall include the following:

---

<sup>1</sup> California Code of Regulations, Title 23, section 2250(b), defines an unauthorized discharge to be a discharge, not regulated by waste discharge requirements, of treated, partially treated, or untreated wastewater resulting from the intentional or unintentional diversion of wastewater from a collection, treatment or disposal system.



- 1) Incident description and cause;
- 2) Location of threatened or involved waterway(s) or storm drains;
- 3) Date and time the unauthorized discharge started;
- 4) Estimated quantity and duration of the unauthorized discharge (to the extent known), and the estimated amount recovered;
- 5) Level of treatment prior to discharge (e.g., raw wastewater, primary treated, undisinfected secondary treated, and so on); and
- 6) Identity of the person reporting the unauthorized discharge.

b. 24-hour Certification

Within 24 hours, the Discharger shall certify to the Regional Water Board, at [www.wbers.net](http://www.wbers.net), that the State Office of Emergency Services and the local health officers or directors of environmental health with jurisdiction over the affected water bodies have been notified of the unauthorized discharge.

c. 5-Day Written Report

Within five business days, the Discharger shall submit a written report, via the Regional Water Board's online reporting system at [www.wbers.net](http://www.wbers.net), that includes, in addition to the information required above, the following:

- 1) Methods used to delineate the geographical extent of the unauthorized discharge within receiving waters;
- 2) Efforts implemented to minimize public exposure to the unauthorized discharge;
- 3) Visual observations of the impacts (if any) noted in the receiving waters (e.g., fish kill, discoloration of water) and the extent of sampling if conducted;
- 4) Corrective measures taken to minimize the impact of the unauthorized discharge;
- 5) Measures to be taken to minimize the chances of a similar unauthorized discharge occurring in the future;
- 6) Summary of Spill Prevention Plan or O&M Manual modifications to be made, if necessary, to minimize the chances of future unauthorized discharges; and

7) Quantity and duration of the unauthorized discharge, and the amount recovered.

d. Communication Protocol

To clarify the multiple levels of notification, certification, and reporting, the current communication requirements for unauthorized discharges from municipal wastewater treatment plants are summarized in Table B, which follows.

**F. Planned Changes – Not supplemented**

**G. Anticipated Noncompliance – Not supplemented**

**H. Other Noncompliance – Not supplemented**

**I. Other Information – Not supplemented**

**VI. STANDARD PROVISIONS – ENFORCEMENT – Not Supplemented**

**VII. ADDITIONAL PROVISIONS – NOTIFICATION LEVELS – Not Supplemented**

**Table B**

Summary of Communication Requirements for Unauthorized Discharges<sup>1</sup> from  
Municipal Wastewater Treatment Plants

<b>Discharger is required to:</b>	<b>Agency Receiving Information</b>	<b>Time frame</b>	<b>Method for Contact</b>
1. Notify	State Office of Emergency Services (OES)	As soon as possible, but not later than <b>2 hours</b> after becoming aware of the unauthorized discharge.	Telephone – (800) 852-7550 (obtain a control number from OES)
	Local health department	As soon as possible, but not later than <b>2 hours</b> after becoming aware of the unauthorized discharge.	Depends on local health department
	Regional Water Board	As soon as possible, but not later than <b>2 hours</b> after becoming aware of the unauthorized discharge.	Electronic <sup>2</sup> <a href="http://www.wbers.net">www.wbers.net</a>
2. Certify	Regional Water Board	As soon as possible, but not later than <b>24 hours</b> after becoming aware of the unauthorized discharge.	Electronic <sup>3</sup> <a href="http://www.wbers.net">www.wbers.net</a>
3. Report	Regional Water Board	Within <b>5 business days</b> of becoming aware of the unauthorized discharge.	Electronic <sup>4</sup> <a href="http://www.wbers.net">www.wbers.net</a>

<sup>1</sup> California Code of Regulations, Title 23, section 2250(b), defines an unauthorized discharge to be a discharge, not regulated by waste discharge requirements, of treated, partially treated, or untreated wastewater resulting from the intentional or unintentional diversion of wastewater from a collection, treatment or disposal system.

<sup>2</sup> In the event that the Discharger is unable to provide online notification within 2 hours of becoming aware of an unauthorized discharge, it shall phone the Regional Water Board’s spill hotline at (510) 622-2369 and convey the same information in the notification form. In addition, within 3 business days of becoming aware of the unauthorized discharge, the Discharger shall enter the notification information into the Regional Water Board’s online system in electronic format.

<sup>3</sup> In most instances, the 2-hour notification will also satisfy 24-hour certification requirements. This is because the notification form includes fields for documenting that OES and the local health department have been contacted. In other words, if the Discharger is able to complete all the fields in the notification form within 2 hours, certification requirements are also satisfied. In the event that the Discharger is unable to provide online certification within 24 hours of becoming aware of an unauthorized discharge, it shall phone the Regional Water Board’s spill hotline at (510) 622-2369 and convey the same information in the certification form. In addition, within 3 business days of becoming aware of the unauthorized discharge, the Discharger shall enter the certification information into the Regional Water Board’s online system in electronic format.

<sup>4</sup> If the Discharger cannot satisfy the 5-day reporting requirements via the Regional Water Board’s online reporting system, it shall submit a written report (preferably electronically in pdf) to the appropriate Regional Water Board case manager. In cases where the Discharger cannot satisfy the 5-day reporting requirements via the online reporting system, it must still complete the Regional Water Board’s online reporting requirements within 15 calendar days of becoming aware of the unauthorized discharge.

**VIII. DEFINITIONS – THIS SECTION IS AN ADDITION TO STANDARD PROVISIONS (ATTACHMENT D)**

More definitions can be found in Attachment A of this NPDES Permit.

1. Arithmetic Calculations

- a. Geometric mean is the antilog of the log mean or the back-transformed mean of the logarithmically transformed variables, which is equivalent to the multiplication of the antilogarithms. The geometric mean can be calculated with either of the following equations:

$$\text{Geometric Mean} = \text{Anti log} \left( \frac{1}{N} \sum_{i=1}^N \text{Log}(C_i) \right)$$

or

$$\text{Geometric Mean} = (C_1 * C_2 * \dots * C_N)^{1/N}$$

Where “N” is the number of data points for the period analyzed and “C” is the concentration for each of the “N” data points.

- b. Mass emission rate is obtained from the following calculation for any calendar day:

$$\text{Mass emission rate (lb/day)} = \frac{8.345}{N} \sum_{i=1}^N Q_i C_i$$

$$\text{Mass emission rate (kg/day)} = \frac{3.785}{N} \sum_{i=1}^N Q_i C_i$$

In which “N” is the number of samples analyzed in any calendar day and “Q<sub>i</sub>” and “C<sub>i</sub>” are the flow rate (MGD) and the constituent concentration (mg/L) associated with each of the “N” grab samples that may be taken in any calendar day. If a composite sample is taken, “C<sub>i</sub>” is the concentration measured in the composite sample and “Q<sub>i</sub>” is the average flow rate occurring during the period over which the samples are composited. The daily concentration of a constituent measured over any calendar day shall be determined from the flow-weighted average of the same constituent in the combined waste streams as follows:

$$C_d = \text{Average daily concentration} = \frac{1}{Q_t} \sum_{i=1}^N Q_i C_i$$

In which “N” is the number of component waste streams and “Q” and “C” are the flow rate (MGD) and the constituent concentration (mg/L) associated with each of the “N” waste streams. “Q<sub>t</sub>” is the total flow rate of the combined waste streams.

- c. Maximum allowable mass emission rate, whether for a 24-hour, weekly 7-day, monthly 30-day, or 6-month period, is a limitation expressed as a daily rate determined with the formulas in the paragraph above, using the effluent concentration limit specified in the permit for the period and the specified allowable flow.
- d. POTW removal efficiency is the ratio of pollutants removed by the treatment facilities to pollutants entering the treatment facilities (expressed as a percentage). The Discharger shall determine removal efficiencies using monthly averages (by calendar month unless otherwise specified) of pollutant concentration of influent and effluent samples collected at about the same time and using the following equation (or its equivalent):

$$\text{Removal Efficiency (\%)} = 100 \times [1 - (\text{Effluent Concentration} / \text{Influent Concentration})]$$

2. Biosolids means the solids, semi-liquid suspensions of solids, residues, screenings, grit, scum, and precipitates separated from or created in wastewater by the unit processes of a treatment system. It also includes, but is not limited to, all supernatant, filtrate, centrate, decantate, and thickener overflow and underflow in the solids handling parts of the wastewater treatment system.
3. Blending is the practice of recombining wastewater that has been biologically treated with wastewater that has bypassed around biological treatment units.
4. Bottom sediment sample is (1) a separate grab sample taken at each sampling station for the determination of selected physical-chemical parameters, or (2) four grab samples collected from different locations in the immediate vicinity of a sampling station while the boat is anchored and analyzed separately for macroinvertebrates.
5. Composite sample is a sample composed of individual grab samples collected manually or by an automatic sampling device on the basis of time or flow as specified in the MRP. For flow-based composites, the proportion of each grab sample included in the composite sample shall be within plus or minus five percent (+/-5%) of the representative flow rate of the waste stream being measured at the time of grab sample collection. Alternatively, equal volume grab samples may be individually analyzed with the flow-weighted average calculated by averaging flow-weighted ratios of each grab sample analytical result. Grab samples comprising time-based composite samples shall be collected at intervals not greater than those specified in the MRP. The quantity of each grab sample comprising a time-based composite sample shall be a set of flow proportional volumes as specified in the MRP. If a particular time-based or flow-based composite sampling protocol is not specified in the MRP, the Discharger shall determine and implement the most representative sampling protocol for the given parameter subject to Executive Officer approval.
6. Depth-integrated sample is defined as a water or waste sample collected by allowing a sampling device to fill during a vertical traverse in the waste or receiving water body

- being sampled. The Discharger shall collect depth-integrated samples in such a manner that the collected sample will be representative of the waste or water body at that sampling point.
7. Flow sample is an accurate measurement of the average daily flow volume using a properly calibrated and maintained flow measuring device.
  8. Grab sample is an individual sample collected in a short period of time not exceeding 15 minutes. Grab samples represent only the condition that exists at the time the wastewater is collected.
  9. Initial dilution is the process that results in the rapid and irreversible turbulent mixing of wastewater with receiving water around the point of discharge.
  10. Overflow is the intentional or unintentional spilling or forcing out of untreated or partially treated wastes from a transport system (e.g., through manholes, at pump stations, and at collection points) upstream from the treatment plant headworks or from any part of a treatment plant facility.
  11. Priority pollutants are those constituents referred to in 40 CFR Part 122 as promulgated in the Federal Register, Vol. 65, No. 97, Thursday, May 18, 2000, also known as the California Toxics Rule, the presence or discharge of which could reasonably be expected to interfere with maintaining designated uses.
  12. Storm water means storm water runoff, snow melt runoff, and surface runoff and drainage. It excludes infiltration and runoff from agricultural land.
  13. Toxic pollutant means any pollutant listed as toxic under federal Clean Water Act section 307(a)(1) or under 40 CFR 401.15.
  14. Untreated waste is raw wastewater.
  15. Waste, waste discharge, discharge of waste, and discharge are used interchangeably in the permit. The requirements of the permit apply to the entire volume of water, and the material therein, that is disposed of to surface and ground waters of the State of California.

**Table C**  
List of Monitoring Parameters and Analytical Methods

CTR No.	Pollutant/Parameter	Analytical Method <sup>1</sup>	Minimum Levels <sup>2</sup> (µg/l)											
			GC	GCMS	LC	Color	FAA	GFAA	ICP	ICP MS	SPGFAA	HYD RIDE	CVAA	DCP
1.	Antimony	204.2					10	5	50	0.5	5	0.5		1000
2.	Arsenic	206.3				20		2	10	2	2	1		1000
3.	Beryllium						20	0.5	2	0.5	1			1000
4.	Cadmium	200 or 213				10	0.5	10	0.25	0.5				1000
5a.	Chromium (III)	SM 3500												
5b.	Chromium (VI)	SM 3500				10	5							1000
6.	Copper	200.9					25	5	10	0.5	2			1000
7.	Lead	200.9					20	5	5	0.5	2			10,000
8.	Mercury	1631 (note) <sup>3</sup>												
9.	Nickel	249.2					50	5	20	1	5			1000
10.	Selenium	200.8 or SM 3114B or C						5	10	2	5	1		1000
11.	Silver	272.2					10	1	10	0.25	2			1000
12.	Thallium	279.2					10	2	10	1	5			1000
13.	Zinc	200 or 289					20		20	1	10			
14.	Cyanide	SM 4500 CN <sup>-</sup> C or I				5								
15.	Asbestos (only required for dischargers to MUN waters) <sup>4</sup>	0100.2 <sup>5</sup>												
16.	2,3,7,8-TCDD and 17 congeners (Dioxin)	1613												
17.	Acrolein	603	2.0	5										
18.	Acrylonitrile	603	2.0	2										
19.	Benzene	602	0.5	2										
33.	Ethylbenzene	602	0.5	2										
39.	Toluene	602	0.5	2										
20.	Bromoform	601	0.5	2										
21.	Carbon Tetrachloride	601	0.5	2										
22.	Chlorobenzene	601	0.5	2										

<sup>1</sup> The suggested method is the USEPA Method unless otherwise specified (SM = Standard Methods). The discharger may use another USEPA-approved or recognized method if that method has a level of quantification below the applicable water quality objective. Where no method is suggested, the Discharger has the discretion to use any standard method.

<sup>2</sup> Minimum levels are from the *State Implementation Policy*. They are the concentration of the lowest calibration standard for that technique based on a survey of contract laboratories. Laboratory techniques are defined as follows: GC = Gas Chromatography; GCMS = Gas Chromatography/Mass Spectrometry; LC = High Pressure Liquid Chromatography; Color = Colorimetric; FAA = Flame Atomic Absorption; GFAA = Graphite Furnace Atomic Absorption; ICP = Inductively Coupled Plasma; ICPMS = Inductively Coupled Plasma/Mass Spectrometry; SPGFAA = Stabilized Platform Graphite Furnace Atomic Absorption (i.e., USEPA 200.9); Hydride = Gaseous Hydride Atomic Absorption; CVAA = Cold Vapor Atomic Absorption; DCP = Direct Current Plasma.

<sup>3</sup> The Discharger shall use ultra-clean sampling (USEPA Method 1669) and ultra-clean analytical methods (USEPA Method 1631) for mercury monitoring. The minimum level for mercury is 2 ng/l (or 0.002 µg/l).

<sup>4</sup> MUN = Municipal and Domestic Supply. This designation, if applicable, is in the Findings of the permit.

<sup>5</sup> Determination of Asbestos Structures over 10 [micrometers] in Length in Drinking Water Using MCE Filters, USEPA 600/R-94-134, June 1994.

CTR No.	Pollutant/Parameter	Analytical Method <sup>1</sup>	Minimum Levels <sup>2</sup> (µg/l)											
			GC	GCMS	LC	Color	FAA	GFAA	ICP	ICP MS	SPGFAA	HYD RIDE	CVAA	DCP
23.	Chlorodibromomethane	601	0.5	2										
24.	Chloroethane	601	0.5	2										
25.	2-Chloroethylvinyl Ether	601	1	1										
26.	Chloroform	601	0.5	2										
75.	1,2-Dichlorobenzene	601	0.5	2										
76.	1,3-Dichlorobenzene	601	0.5	2										
77.	1,4-Dichlorobenzene	601	0.5	2										
27.	Dichlorobromomethane	601	0.5	2										
28.	1,1-Dichloroethane	601	0.5	1										
29.	1,2-Dichloroethane	601	0.5	2										
30.	1,1-Dichloroethylene or 1,1-Dichloroethene	601	0.5	2										
31.	1,2-Dichloropropane	601	0.5	1										
32.	1,3-Dichloropropylene or 1,3-Dichloropropene	601	0.5	2										
34.	Methyl Bromide or Bromomethane	601	1.0	2										
35.	Methyl Chloride or Chloromethane	601	0.5	2										
36.	Methylene Chloride or Dichlorormethane	601	0.5	2										
37.	1,1,2,2-Tetrachloroethane	601	0.5	1										
38.	Tetrachloroethylene	601	0.5	2										
40.	1,2-Trans-Dichloroethylene	601	0.5	1										
41.	1,1,1-Trichloroethane	601	0.5	2										
42.	1,1,2-Trichloroethane	601	0.5	2										
43.	Trichloroethene	601	0.5	2										
44.	Vinyl Chloride	601	0.5	2										
45.	2-Chlorophenol	604	2	5										
46.	2,4-Dichlorophenol	604	1	5										
47.	2,4-Dimethylphenol	604	1	2										
48.	2-Methyl-4,6-Dinitrophenol or Dinitro-2-methylphenol	604	10	5										
49.	2,4-Dinitrophenol	604	5	5										
50.	2-Nitrophenol	604		10										
51.	4-Nitrophenol	604	5	10										
52.	3-Methyl-4-Chlorophenol	604	5	1										
53.	Pentachlorophenol	604	1	5										
54.	Phenol	604	1	1		50								
55.	2,4,6-Trichlorophenol	604	10	10										
56.	Acenaphthene	610 HPLC	1	1	0.5									
57.	Acenaphthylene	610 HPLC		10	0.2									
58.	Anthracene	610 HPLC		10	2									
60.	Benzo(a)Anthracene or 1,2 Benzanthracene	610 HPLC	10	5										
61.	Benzo(a)Pyrene	610 HPLC		10	2									
62.	Benzo(b)Fluoranthene or 3,4 Benzo(b)fluoranthene	610 HPLC		10	10									
63.	Benzo(ghi)Perylene	610 HPLC		5	0.1									
64.	Benzo(k)Fluoranthene	610 HPLC		10	2									
74.	Dibenzo(a,h)Anthracene	610 HPLC		10	0.1									
86.	Fluoranthene	610 HPLC	10	1	0.05									



CTR No.	Pollutant/Parameter	Analytical Method <sup>1</sup>	Minimum Levels <sup>2</sup> (µg/l)											
			GC	GCMS	LC	Color	FAA	GFAA	ICP	ICP MS	SPGFAA	HYD RIDE	CVAA	DCP
87.	Fluorene	610 HPLC		10	0.1									
92.	Indeno(1,2,3-cd) Pyrene	610 HPLC		10	0.05									
100.	Pyrene	610 HPLC		10	0.05									
68.	Bis(2-Ethylhexyl)Phthalate	606 or 625	10	5										
70.	Butylbenzyl Phthalate	606 or 625	10	10										
79.	Diethyl Phthalate	606 or 625	10	2										
80.	Dimethyl Phthalate	606 or 625	10	2										
81.	Di-n-Butyl Phthalate	606 or 625		10										
84.	Di-n-Octyl Phthalate	606 or 625		10										
59.	Benidine	625		5										
65.	Bis(2-Chloroethoxy)Methane	625		5										
66.	Bis(2-Chloroethyl)Ether	625	10	1										
67.	Bis(2-Chloroisopropyl)Ether	625	10	2										
69.	4-Bromophenyl Phenyl Ether	625	10	5										
71.	2-Chloronaphthalene	625		10										
72.	4-Chlorophenyl Phenyl Ether	625		5										
73.	Chrysene	625		10	5									
78.	3,3'-Dichlorobenzidine	625		5										
82.	2,4-Dinitrotoluene	625	10	5										
83.	2,6-Dinitrotoluene	625		5										
85.	1,2-Diphenylhydrazine (note) <sup>6</sup>	625		1										
88.	Hexachlorobenzene	625	5	1										
89.	Hexachlorobutadiene	625	5	1										
90.	Hexachlorocyclopentadiene	625	5	5										
91.	Hexachloroethane	625	5	1										
93.	Isophorone	625	10	1										
94.	Naphthalene	625	10	1	0.2									
95.	Nitrobenzene	625	10	1										
96.	N-Nitrosodimethylamine	625	10	5										
97.	N-Nitrosodi-n-Propylamine	625	10	5										
98.	N-Nitrosodiphenylamine	625	10	1										
99.	Phenanthrene	625		5	0.05									
101.	1,2,4-Trichlorobenzene	625	1	5										
102.	Aldrin	608	0.005											
103.	α-BHC	608	0.01											
104.	β-BHC	608	0.005											
105.	γ-BHC (Lindane)	608	0.02											
106.	δ-BHC	608	0.005											
107.	Chlordane	608	0.1											
108.	4,4'-DDT	608	0.01											
109.	4,4'-DDE	608	0.05											
110.	4,4'-DDD	608	0.05											
111.	Dieldrin	608	0.01											
112.	Endosulfan (alpha)	608	0.02											
113.	Endosulfan (beta)	608	0.01											

<sup>6</sup> Measurement for 1,2-Diphenylhydrazine may use azobenzene as a screen: if azobenzene is measured at >1 ug/l, then the Discharger shall analyze for 1,2-Diphenylhydrazine.

CTR No.	Pollutant/Parameter	Analytical Method <sup>1</sup>	Minimum Levels <sup>2</sup> (µg/l)											
			GC	GCMS	LC	Color	FAA	GFAA	ICP	ICP MS	SPGFAA	HYD RIDE	CVAA	DCP
114.	Endosulfan Sulfate	608	0.05											
115.	Endrin	608	0.01											
116.	Endrin Aldehyde	608	0.01											
117.	Heptachlor	608	0.01											
118.	Heptachlor Epoxide	608	0.01											
119-125	PCBs: Aroclors 1016, 1221, 1232, 1242, 1248, 1254, 1260	608	0.5											
126.	Toxaphene	608	0.5											