

Appendix A

Revised Tentative Order

San Francisco Bay Regional Water Quality Control Board

REVISED TENTATIVE ORDER No. R2-2013-XXXX
NPDES No. CA0037753

The following discharger and discharge points are subject to waste discharge requirements set forth in this Order.

Table 1. Discharger Information

Discharger	Sanitary District No. 5 of Marin County
Name of Facility	Sanitary District No. 5 Wastewater Treatment Plant and wastewater collection system
CIWQS Place Number	239497
Facility Address	2001 Paradise Drive, Tiburon, CA 94920, Marin County
The U.S. Environmental Protection Agency (USEPA) and the San Francisco Bay Regional Water Quality Control Board have classified this discharge as a major discharge.	

Table 2. Discharge Location

Discharge Point	Effluent Description	Discharge Point Latitude	Discharge Point Longitude	Receiving Water
001	Secondary-Treated Wastewater	37° 52' 12" N	122° 27' 05" W	Raccoon Strait in Central San Francisco Bay

Table 3. Administrative Information

This Order was adopted by the Regional Water Quality Control Board on:	DATE
This Order shall become effective on:	October 1, 2013
This Order shall expire on:	September 30, 2018
The Discharger shall file a Report of Waste Discharge in accordance with Title 23, California Code of Regulations, as application for re-issuance of waste discharge requirements no later than:	April 3, 2018

I, Bruce H. Wolfe, Executive Officer, do hereby certify that this Order with all attachments is a full, true, and correct copy of an Order adopted by the California Regional Water Quality Control Board, San Francisco Bay Region, on the date indicated above.

Bruce H. Wolfe, Executive Officer

Contents

I. Facility Information..... 3
 II. Findings..... 3
 III. Discharge Prohibitions 7
 IV. Effluent Limitations and Discharge Specifications..... 8
 A. Effluent Limitations for Conventional and Non-Conventional Pollutants..... 8
 B. Toxic Substances Effluent Limitations 9
 C. Whole Effluent Toxicity..... 9
 V. Receiving Water Limitations..... 10
 VI. Provisions..... 11
 A. Standard Provisions..... 11
 B. MRP Requirements 11
 C. Special Provisions 12
 1. Reopener Provisions..... 12
 2. Effluent Characterization Study and Report 12
 3. Best Management Practices and Pollutant Minimization Program..... 13
 4. Special Provisions for POTWs..... 16
 5. Other Special Provisions 17
 VII. Compliance Determination..... 20

Tables

Table 1. Discharger Information..... 1
 Table 2. Discharge Location..... 1
 Table 3. Administrative Information 1
 Table 4. Facility Information 3
 Table 5. Basin Plan Beneficial Uses..... 5
 Table 6. Conventional and Non-Conventional Pollutant Effluent Limitations 8
 Table 7. Toxic Pollutant Effluent Limitations 9
 Table 8. Specific Tasks to Improve Wet Weather Management and Reduce Blending..... 17
 Table 9. Copper Action Plan..... 19
 Table 10. Cyanide Action Plan 20

Attachments

Attachment A – Definitions..... A-1
 Attachment B – Facility Map..... B-1
 Attachment C – Process Flow Diagram..... C-1
 Attachment D – Federal Standard Provisions..... D-1
 Attachment E – Monitoring and Reporting Program (MRP)..... E-1
 Attachment F – Fact Sheet..... F-1
 Attachment G – Regional Standard Provisions and Monitoring and Reporting Requirements G-1

I. FACILITY INFORMATION

The following facility is subject to the waste discharge requirements set forth in this Order:

Table 4. Facility Information

Discharger	Sanitary District No. 5 of Marin County
Name of Facility	Sanitary District No. 5 Wastewater Treatment Plant and wastewater collection system
Facility Address	2001 Paradise Drive, Tiburon, Marin County, CA 94920
CIWQS Place Number	239497
Facility Contact, Title, Phone	Tony Rubio Wastewater Facilities Manager (415) 435-1501 ext. 106 trubio@sani5.org
Mailing Address	P.O. Box 227, Tiburon, CA 94920
Type of Facility	Publicly Owned Treatment Works
Facility Design Flow	0.98 million gallons per day (MGD) (average dry weather flow) 2.3 MGD (peak wet weather flow)
Service Area	Town of Tiburon, City of Belvedere, and surrounding unincorporated area.
Service Population	Approximately 8,400

II. FINDINGS

The California Regional Water Quality Control Board, San Francisco Bay Region (hereinafter Regional Water Board), finds:

A. Background. The Sanitary District No. 5 of Marin County (hereinafter Discharger) is currently discharging under Regional Water Board Order No. R2-2008-0057, National Pollutant Discharge Elimination System (NPDES) Permit No. CA0037753. The Discharger submitted a Report of Waste Discharge dated March 1, 2013, and applied for an NPDES permit reissuance to discharge treated wastewater from its wastewater treatment plant located at 2001 Paradise Drive, Tiburon, to waters of the State and the United States.

The discharge is also regulated under Order No. R2-2012-0096 (NPDES Permit CA0038849), which establishes requirements on mercury and polychlorinated biphenyls (PCBs) from wastewater discharges in the region. This Order does not affect the mercury and PCBs permit.

For the purposes of this Order, references to the “discharger” or “permittee” in applicable federal and State laws, regulations, plans, or policy are held to be equivalent to references to the Discharger herein.

B. Facility Description and Discharge Location

The Discharger owns and operates the Sanitary District No. 5 Wastewater Treatment Plant (hereinafter the Plant) and its associated wastewater collection system, consisting of 33 miles of gravity sewer line, 5 miles of forcemain, and 22 pump stations (hereinafter, collectively, the Facility). The Plant provides secondary treatment of domestic and commercial wastewater for the Town of Tiburon, the City of Belvedere, and a small unincorporated area of the Tiburon Peninsula around the treatment plant. The service area population is approximately 8,400. The Plant has a dry

weather design capacity of 0.98 MGD and can treat up to 2.3 MGD during wet weather. From January 2010 through December 2012, the average annual flow was 0.63 MGD, with a maximum daily flow of 2.56 MGD. Attachment B provides a map of the area around the Facility.

The treatment process consists of grinding, primary sedimentation, activated sludge biological treatment, secondary sedimentation, disinfection (sodium hypochlorite), and dechlorination (sodium bisulfite). Treated effluent from the Plant is combined with final effluent from the Sewerage Agency of Southern Marin before discharge into Raccoon Strait in Central San Francisco Bay via a submerged outfall 850 feet offshore at a depth of 84 feet below mean sea level (Discharge Point No. 001). Solids collected from wastewater treatment processes are thickened, anaerobically digested, dewatered, and disposed of at the Redwood Sanitary Landfill in Novato. Attachment C provides a treatment process schematic diagram.

During wet weather, when influent flow exceeds 2.3 MGD, a portion of the primary-treated effluent may be diverted around the secondary treatment units and blended with secondary-treated effluent prior to disinfection and discharge. Such bypass, or blending, prevents a washout of microbial populations in the secondary treatment units, which are crucial to achieving compliance with secondary treatment standards.

- C. Legal Authorities.** This Order is issued pursuant to Clean Water Act (CWA) section 402 and implements regulations adopted by USEPA and California Water Code (CWC) chapter 5.5, division 7, commencing with section 13370. It serves as an NPDES permit for point source discharges from the Facility to surface waters. This Order also serves as Waste Discharge Requirements (WDRs) pursuant to CWC article 4, chapter 4, division 7, commencing with section 13260.
- D. Background and Rationale for Requirements.** The requirements in this Order are based on information submitted as part of the application, through monitoring and reporting programs, and other available information. The Fact Sheet, which contains background information and rationale for requirements of the Order, is hereby incorporated into this Order and constitutes part of the findings for this Order. Attachments A through E and G are also incorporated into this Order.
- E. California Environmental Quality Act (CEQA).** Under CWC section 13389, this action to adopt an NPDES permit is exempt from Chapter 3 of CEQA.
- F. Technology-Based Effluent Limitations.** CWA section 301(b) and NPDES regulations at Title 40 of the Code of Federal Regulations section 122.44 (40 CFR 122.44) require that permits include conditions meeting applicable technology-based requirements at minimum and any more stringent effluent limitations necessary to meet applicable water quality standards. The discharge authorized by this Order must meet minimum federal technology-based requirements based on Secondary Treatment Standards at 40 CFR 133. Further discussion of the technology-based effluent limitations is included in the Fact Sheet.
- G. Water Quality-Based Effluent Limitations.** CWA section 301(b) and 40 CFR 122.44(d) require that permits include limitations more stringent than applicable federal technology-based requirements where necessary to achieve applicable water quality standards. NPDES regulations at 40 CFR 122.44(d)(1)(i) mandate that permits include effluent limitations for all pollutants that are or may be discharged at levels that have the reasonable potential to cause or contribute to an exceedance of a water quality standard, including numeric and narrative objectives within a

standard. Where reasonable potential has been established for a pollutant, but there is no numeric criterion or objective for the pollutant, water quality-based effluent limitations (WQBELs) must be established using (1) USEPA criteria guidance under CWA section 304(a), supplemented where necessary by other relevant information; (2) an indicator parameter for the pollutant of concern; or (3) a calculated numeric water quality criterion (WQC), such as a proposed state criterion or policy interpreting the state’s narrative criterion, supplemented with other relevant information, as provided in 40 CFR 122.44(d)(1)(vi).

H. Water Quality Control Plan. *The Water Quality Control Plan for the San Francisco Bay Basin* (hereinafter Basin Plan) is the Regional Water Board’s master water quality control planning document. It designates beneficial uses and water quality objectives for waters of the State, including surface and groundwater. It also includes implementation programs to achieve water quality objectives. The Basin Plan was duly adopted by the Regional Water Board and approved by the State Water Resources Control Board (State Water Board), the Office of Administrative Law, and USEPA. Requirements of this Order implement the Basin Plan. Basin Plan beneficial uses for Central San Francisco Bay are listed in the table below:

Table 5. Basin Plan Beneficial Uses

Receiving Water Name	Beneficial Uses
Central San Francisco Bay	Industrial Service Supply (IND) Industrial Process Supply (PROC) Commercial and Sport Fishing (COMM) Shellfish Harvesting (SHELL) Estuarine Habitat (EST) Fish Migration (MIGR) Preservation of Rare and Endangered Species (RARE) Fish Spawning (SPWN) Wildlife Habitat (WILD) Water Contact Recreation (REC1) Non-Contact Water Recreation (REC2) Navigation (NAV)

The State Water Board’s *Water Quality Control Plan for Enclosed Bays and Estuaries—Part 1, Sediment Quality* became effective on August 25, 2009. This plan supersedes other narrative sediment quality objectives and establishes new sediment quality objectives and related implementation provisions for specifically defined sediments in most bays and estuaries.

- I. National Toxics Rule (NTR) and California Toxics Rule (CTR).** USEPA adopted the NTR on December 22, 1992, and later amended it on May 4, 1995, and November 9, 1999. About 40 criteria in the NTR apply in California. On May 18, 2000, USEPA adopted the CTR, which promulgated new toxics criteria for California and, in addition, incorporated the previously adopted NTR criteria that applied in the State. The CTR was amended on February 13, 2001. These rules contain WQC for priority pollutants.
- J. State Implementation Policy.** On March 2, 2000, the State Water Board adopted the *Policy for Implementation of Toxics Standards for Inland Surface Waters, Enclosed Bays, and Estuaries of California* (hereinafter State Implementation Policy [SIP]). The SIP became effective on April 28, 2000, with respect to the priority pollutant criteria promulgated through the NTR and to the priority pollutant objectives established in the Basin Plan. The SIP became effective on May 18, 2000, with

respect to the priority pollutant criteria USEPA promulgated through the CTR. The State Water Board adopted amendments to the SIP on February 24, 2005, that became effective on July 13, 2005. The SIP establishes implementation provisions for priority pollutant criteria and objectives and provisions for chronic toxicity control. Requirements of this Order implement the SIP.

- K. Alaska Rule.** On March 30, 2000, USEPA revised its regulation that specifies when new and revised state and tribal water quality standards become effective for CWA purposes (65 Fed. Reg. 24641 [April 27, 2000], codified at 40 CFR 131.21). Under the revised regulation (also known as the Alaska Rule), new and revised standards submitted to USEPA after May 30, 2000, must be approved by USEPA before being used for CWA purposes. The final rule also provides that standards already in effect and submitted to USEPA by May 30, 2000, may be used for CWA purposes, whether or not approved by USEPA.
- L. Stringency of Requirements for Individual Pollutants.** This Order contains both technology-based and WQBELs for individual pollutants. Derivation of these technology-based limitations is discussed in the Fact Sheet. This Order’s technology-based pollutant restrictions implement the minimum applicable federal technology-based requirements. In addition, this Order contains effluent limitations more stringent than the minimum federal technology-based requirements as necessary to meet water quality standards.

WQBELs have been derived to implement water quality objectives that protect beneficial uses. Both the beneficial uses and the water quality objectives have been approved pursuant to federal law and are the applicable federal water quality standards. To the extent that toxic pollutant WQBELs were derived from the CTR, the CTR is the applicable standard pursuant to 40 CFR 131.38. On May 18, 2000, USEPA approved the procedures for calculating individual WQBELs for priority pollutants based on the SIP. Most beneficial uses and water quality objectives contained in the Basin Plan were approved under State law and submitted to USEPA. Any water quality objectives and beneficial uses submitted to USEPA prior to May 30, 2000, but not approved by USEPA before that date, are nonetheless “applicable water quality standards for the purposes of the CWA” pursuant to 40 CFR 131.21(c)(1). Collectively, this Order’s restrictions on individual pollutants are no more stringent than those required by CWA water quality standards.

- M. Antidegradation Policy.** NPDES regulations at 40 CFR 131.12 require that state water quality standards include an antidegradation policy consistent with the federal policy. The State Water Board established California’s antidegradation policy in State Water Board Resolution No. 68-16, which incorporates the federal antidegradation policy where the federal policy applies under federal law and requires that existing quality of waters be maintained unless degradation is justified based on specific findings. The Basin Plan implements, and incorporates by reference, both the State and federal antidegradation policies.
- N. Anti-Backsliding Requirements.** CWA sections 402(o)(2) and 303(d)(4) and 40 CFR 122.44(l) prohibit backsliding in NPDES permits. These anti-backsliding provisions require effluent limitations in a reissued permit to be as stringent as those in the previous order, with some exceptions where limitations may be relaxed.
- O. Endangered Species Act.** This Order does not authorize any act that results in the taking of a threatened or endangered species or any act that is now prohibited, or becomes prohibited in the future, under either the California Endangered Species Act (Fish and Game Code sections 2050 to

2097) or the federal Endangered Species Act (16 U.S.C.A. sections 1531 to 1544). This Order requires compliance with effluent limits, receiving water limits, and other requirements to protect the beneficial uses of waters of the State. The Discharger is responsible for meeting all requirements of applicable State and federal law pertaining to threatened and endangered species.

- P. Monitoring and Reporting.** NPDES regulations at 40 CFR 122.48 require that all NPDES permits specify requirements for recording and reporting monitoring results. CWC sections 13267 and 13383 authorize the Regional Water Board to require technical and monitoring reports. The Monitoring and Reporting Program (MRP, Attachment E) establishes monitoring and reporting requirements to implement federal and State requirements.
- Q. Standard and Special Provisions.** Attachment D contains Federal Standard Provisions that apply to all NPDES permits in accordance with 40 CFR 122.41, and additional conditions applicable to specified categories of permits in accordance with 40 CFR 122.42. The Discharger must comply with all standard provisions and with those additional conditions that apply under 40 CFR 122.42. The Discharger must also comply with the Regional Standard Provisions provided in Attachment G. The Regional Water Board has also included in this Order special provisions applicable to the Discharger. The Fact Sheet provides rationales for the special provisions.
- R. Provisions and Requirements Implementing State Law.** None of the requirements in this Order are included to implement State law only.
- S. Notification of Interested Parties.** The Regional Water Board notified the Discharger and interested agencies and persons of its intent to prescribe WDRs for the discharge and provided them with an opportunity to submit written comments and recommendations. The Fact Sheet provides details of the notification.
- T. Consideration of Public Comment.** The Regional Water Board, in a public meeting, heard and considered all comments pertaining to the discharge. The Fact Sheet provides details of the public hearing.

IT IS HEREBY ORDERED, that this Order supersedes Order No. R2-2008-0057, as amended by Order No. R2-2010-0054, except for enforcement purposes, and, in order to meet the provisions contained in CWC Division 7 (commencing with section 13000) and regulations adopted thereunder, and the provisions of the CWA and regulations and guidelines adopted thereunder, the Discharger shall comply with the requirements in this Order.

III. DISCHARGE PROHIBITIONS

- A.** Discharge of treated wastewater at a location or in a manner different from that described in this Order is prohibited.
- B.** Discharge at any point at which the treated wastewater does not receive an initial dilution of at least 88:1 (nominal) is prohibited. Compliance shall be achieved by proper operation and maintenance of the discharge outfall to ensure that it (or its replacement, in whole or in part) is in good working order and is consistent with or can achieve better mixing than that described in the Fact Sheet. The Discharger shall address measures taken to ensure this in its application for permit reissuance.

- C. The bypass of untreated or partially-treated wastewater to waters of the United States is prohibited, except as provided for in the conditions stated in Attachment D section I.G of this Order.

Blended wastewater is biologically-treated wastewater blended with wastewater diverted around biological treatment units or advanced treatment units. Such discharges are approved under the bypass conditions stated in 40 CFR 122.41(m)(4) when (1) the Discharger’s peak wet weather influent flow exceeds the Plant’s maximum treatment capacity of 2.3 MGD, (2) the discharge complies with the effluent and receiving water limitations contained in this Order, and (3) the Discharger is in compliance with Provision VI.C.5.a. Furthermore, the Discharger shall operate the Facility as designed and in accordance with the Operation and Maintenance Manual for the Facility. This means it shall optimize storage and use of equalization units and shall fully use its biological treatment units and advanced treatment units, if applicable. This also means that it must maximize treatment and minimize sanitary sewer overflows from its collection system. The Discharger shall report incidents of blended effluent discharges in routine monitoring reports and shall monitor this discharge as specified in the MRP.

- D. The average dry weather effluent flow, measured at Monitoring Location EFF-001 as described in the MRP, shall not exceed 0.98 MGD. Actual average dry weather flow shall be determined for compliance with this prohibition over three consecutive dry weather months each year.
- E. Any sanitary sewer overflow that results in a discharge of untreated or partially-treated wastewater to waters of the United States is prohibited.

IV. EFFLUENT LIMITATIONS AND DISCHARGE SPECIFICATIONS

A. Effluent Limitations for Conventional and Non-Conventional Pollutants

- 1. Discharges at Discharge Point No. 001 shall comply with the following effluent limitations with compliance measured at Monitoring Locations EFF-001, EFF-001D, or EFF-001B as described in the MRP.

Table 6. Conventional and Non-Conventional Pollutant Effluent Limitations

Parameter	Units	Effluent Limitations				
		Average Monthly	Average Weekly	Maximum Daily	Instantaneous Minimum	Instantaneous Maximum
Biochemical Oxygen Demand 5-day @ 20°C (BOD ₅)	mg/L	30	45	---	---	---
Total Suspended Solids (TSS)	mg/L	30	45	---	---	---
BOD ₅ and TSS percent removal ^[1]	%	85 minimum	---	---	---	---
Oil and Grease	mg/L	10	---	20	---	---
pH ^[2]	s.u.	---	---	---	6.0	9.0
Total Chlorine Residual ^[3]	mg/L	---	---	---	---	0.0

Footnotes:

mg/L = milligrams per liter
 s.u. = standard units

^[1] The arithmetic mean of BOD₅ at 20°C and TSS, by concentration, for effluent samples collected in each calendar month shall not exceed 15 percent of the arithmetic mean of the respective values, by concentration, for influent samples collected at INF-001 as described in the MRP at approximately the same times during the same period.

- [2] If the Discharger monitors pH continuously, pursuant to 40 CFR 401.17, the Discharger shall be in compliance with the pH limitation specified herein provided that both of the following conditions are satisfied: (i) the total time during which the pH values are outside the required range of pH values shall not exceed 7 hours and 26 minutes in any calendar month; and (ii) no individual excursion from the range of pH values shall exceed 60 minutes.
- [3] The Discharger may elect to use continuous on-line monitoring systems to measure flows, chlorine residual and sodium bisulfate (or other dechlorinating chemical) dosage (including a safety factor) and concentration to prove that chlorine residual exceedances are false positives. If convincing evidence is provided, Regional Water Board staff may conclude that these false positive chlorine residual exceedances are not violations of this limitation.

2. The Discharger shall meet the following limits of bacteriological quality, with compliance measured at Monitoring Locations EFF-001 or EFF-001B as described in the MRP:

- a. **Total Coliform Bacteria:** The median value for the Most Probable Number (MPN) of total coliform bacteria in all samples collected within each calendar month shall not exceed 240 MPN/100 mL, and the daily maximum value shall not exceed 10,000 MPN/100 mL.
- b. **Enterococcus Bacteria:** The geometric mean enterococci bacteria concentration of all samples collected within each calendar month shall not exceed 35 MPN/100 mL.

B. Toxic Substances Effluent Limitations

Discharges at Discharge Point No. 001 shall comply with the following effluent limitations with compliance measured at Monitoring Locations EFF-001, EFF-001D, or EFF-001B as described in the MRP:

Table 7. Toxic Pollutant Effluent Limitations

Constituent	Units	Effluent Limitations ^[1,2]	
		Average Monthly	Maximum Daily
Copper	µg/L	54	73
Cyanide	µg/L	19	45
Dioxin-TEQ	µg/L	1.4 x 10 ⁻⁸	2.8 x 10 ⁻⁸
Total Ammonia, as N	mg/L	100	190

Footnotes:

µg/L = micrograms per liter
 mg/L = milligrams per liter

[1] Limitations apply to the average concentration of all samples collected during the averaging period (daily = 24-hour period; monthly = calendar month).

[2] All limitations for metals are expressed as total recoverable metals.

C. Whole Effluent Toxicity

1. Whole Effluent Acute Toxicity

- a. Discharges at Discharge Point No. 001 shall meet the following limits for acute toxicity. Bioassays shall be conducted in compliance with MRP section V.A with compliance measured at EFF-001 as described in the MRP:
- (1) An eleven (11) – sample median value of not less than 90 percent survival; and
- (2) An eleven (11) – sample 90th percentile value of not less than 70 percent survival.

- b. These acute toxicity limitations are further defined as follows:
 - (1) **11-sample median.** A bioassay test showing survival of less than 90 percent represents a violation of this effluent limit, if five or more of the past ten or less bioassay tests show less than 90 percent survival.
 - (2) **11-sample 90th percentile.** A bioassay test showing survival of less than 70 percent represents a violation of this effluent limit, if one or more of the past ten or less bioassay tests show less than 70 percent survival.
- c. Bioassays shall be performed using the most up-to-date USEPA protocols and species as specified in MRP section V.A. Bioassays shall be conducted in compliance with *Methods for Measuring the Acute Toxicity of Effluents and Receiving Water to Freshwater and Marine Organisms*, currently 5th Edition (EPA-821-R-02-012). If these protocols prove unworkable, the Executive Officer and the Environmental Laboratory Accreditation Program may grant exceptions in writing upon the Discharger's request with justification.
- d. If the Discharger can demonstrate that toxicity exceeding the levels cited above is caused by ammonia and that the ammonia in the discharge complies with ammonia effluent limits, then such toxicity does not constitute a violation of this effluent limitation.

2. Whole Effluent Chronic Toxicity

The discharge shall not contain chronic toxicity at a level that would cause or contribute to toxicity in the receiving water. Chronic toxicity is a detrimental biological effect of growth rate, reproduction, fertilization success, larval development, or any other relevant measure of the health of an organism population or community. Compliance with this limit shall be determined by analysis of indicator organisms and toxicity tests measured at Monitoring Location EFF-001 as described in the MRP.

V. RECEIVING WATER LIMITATIONS

- A. The discharge of waste shall not cause the following conditions to exist in waters of the State:
 - 1. Floating, suspended, or deposited macroscopic particulate matter or foams;
 - 2. Bottom deposits or aquatic growths to the extent that such deposits or growths cause nuisance or adversely affect beneficial uses;
 - 3. Alteration of temperature, turbidity, or apparent color beyond present natural background levels;
 - 4. Visible, floating, suspended, or deposited oil or other products of petroleum origin; and
 - 5. Toxic or other deleterious substances to be present in concentrations or quantities that cause deleterious effects on wildlife, waterfowl, or other aquatic biota, or render any of these unfit for human consumption, either at levels created in the receiving waters or as a result of biological concentration.

B. The discharge of waste shall not cause the following limits to be exceeded in waters of the State within 1 foot of the water surface:

1. Dissolved Oxygen 5.0 mg/L, minimum

Furthermore, the median dissolved oxygen concentration for any three consecutive months shall not be less than 80% of the dissolved oxygen content at saturation. When natural factors cause concentrations less than that specified above, the discharge shall not cause further reduction in ambient dissolved oxygen concentrations.

2. Dissolved Sulfide Natural background levels

3. pH The pH shall not be depressed below 6.5 or raised above 8.5. The discharge shall not cause changes greater than 0.5 pH units in normal ambient pH levels.

4. Nutrients Waters shall not contain biostimulatory substances in concentrations that promote aquatic growths to the extent that such growths cause nuisance or adversely affect beneficial uses.

C. The discharge shall not cause a violation of any particular water quality standard for receiving waters adopted by the Regional Water Board or the State Water Board as required by the CWA and regulations adopted thereunder. If more stringent applicable water quality standards are promulgated or approved pursuant to CWA section 303, or amendments thereto, the Regional Water Board may revise and modify this Order in accordance with such more stringent standards.

VI. PROVISIONS

A. Standard Provisions

- 1. Federal Standard Provisions.** The Discharger shall comply with the Federal Standard Provisions in Attachment D of this Order.
- 2. Regional Standard Provisions.** The Discharger shall comply with all applicable items of the Regional Standard Provisions and the Monitoring and Reporting Requirements (Supplement to Attachment D) for NPDES Wastewater Discharge Permits (Attachment G), including amendments thereto.

B. MRP Requirements

The Discharger shall comply with the MRP and future revisions thereto, including applicable sampling and reporting requirements in the standard provisions listed in Provision VI.A above.

C. Special Provisions

1. Reopener Provisions

The Regional Water Board may modify or reopen this Order prior to its expiration date in any of the following circumstances as allowed by law:

- a. If present or future investigations demonstrate that the discharges governed by this Order have or will have a reasonable potential to cause or contribute to, or will cease to have, adverse impacts on water quality or beneficial uses of the receiving waters.
- b. If new or revised water quality objectives or total maximum daily loads (TMDLs) come into effect for the San Francisco Bay Estuary and contiguous water bodies (whether statewide, regional, or site-specific). In such cases, effluent limitations in this Order will be modified as necessary to reflect updated water quality objectives and waste load allocations in TMDLs. Adoption of effluent limitations contained in this Order is not intended to restrict in any way future modifications based on legally-adopted water quality objectives or TMDLs, or as otherwise permitted under federal regulations governing NPDES permit modifications.
- c. If translator, dilution, or other water quality studies provide a basis for determining that a permit condition should be modified.
- d. If State Water Board precedential decisions, new policies, new laws, or new regulations on chronic toxicity or total chlorine residual become available.
- e. If an administrative or judicial decision on a separate NPDES permit or WDRs addresses requirements similar to this discharge.
- f. If the Discharger requests adjustments in effluent limits due to the implementation of stormwater diversion for redirecting dry weather and first flush discharges from the storm drain system to the sanitary sewer system as a stormwater pollutant control strategy.
- g. Or as otherwise authorized by law.

The Discharger may request permit modification based on any of the circumstances described above. With any such request, the Discharger shall include antidegradation and anti-backsliding analyses.

With the consent of the Discharger, the Executive Officer may make minor modifications to this Order for the purposes set forth in 40 CFR 122.63.

2. Effluent Characterization Study and Report

a. Study Elements

The Discharger shall continue to characterize and evaluate the discharge to verify that the “no” or “cannot determine” reasonable potential analysis conclusions of this Order remain valid and to inform the next permit reissuance. The Discharger shall collect

representative samples of the discharge at EFF-001 as described in the MRP at a minimum of once per calendar year.

The samples shall be analyzed for the priority pollutants listed in Attachment G, Table C, except for those priority pollutants with effluent limitations where the MRP already requires monitoring. Compliance with this requirement shall be achieved in accordance with the specifications of Attachment G, sections III.A.1 and III.A.2.

The Discharger shall evaluate on an annual basis if concentrations of any of these priority pollutants significantly increase over past performance. The Discharger shall investigate the cause of such increase. The investigation may include, but need not be limited to, an increase in monitoring frequency, monitoring of internal process streams, and monitoring of influent sources. The Discharger shall establish remedial measures addressing any increase resulting in reasonable potential to cause or contribute to an excursion above applicable water quality objectives. This requirement may be satisfied through identification of the constituent as a “pollutant of concern” in the Discharger’s Pollutant Minimization Program, described in Provision VI.C.3.

b. Reporting Requirements

(1) Routine Reporting

The Discharger shall, within 30 days of receipt of analytical results, report in the transmittal letter for the appropriate monthly self-monitoring report the following:

- (a) Indication that a sample for this characterization study was collected; and
- (b) Identity of priority pollutants detected at or above applicable water quality criteria (see Fact Sheet Table F-8 for the criteria), together with the detected concentrations of those pollutants.

(2) Annual Reporting

The Discharger shall provide a summary of the annual data evaluation and source investigation in the annual self-monitoring report.

(3) Final Report

The Discharger shall submit a final report that presents all these data to the Regional Water Board with the application for permit reissuance due April 3, 2018.

3. Best Management Practices and Pollutant Minimization Program

- a. The Discharger shall continue to improve its existing Pollutant Minimization Program to promote minimization of pollutant loadings to the Plant and therefore to the receiving waters.
- b. The Discharger shall submit an annual report no later than February 28 of each calendar year. Each annual report shall include at least the following information:

- (1) *A brief description of the Plant, its processes, and its service area.*
- (2) *A discussion of the current pollutants of concern.* Periodically, the Discharger shall analyze its own situation to determine which pollutants are currently a problem and which pollutants may be potential future problems. This discussion shall include the reasons for choosing the pollutants.
- (3) *Identification of sources for the pollutants of concern.* This discussion shall include how the Discharger intends to estimate and identify sources of the pollutants. The Discharger shall also identify sources or potential sources not directly within the ability or authority of the Discharger to control, such as pollutants in the potable water supply and air deposition.
- (4) *Identification of tasks to reduce the sources of the pollutants of concern.* This discussion shall identify and prioritize tasks to address the Discharger's pollutants of concern. The Discharger may implement the tasks by itself or participate in group, regional, or national tasks that will address its pollutants of concern. The Discharger is strongly encouraged to participate in group, regional, or national tasks that will address its pollutants of concern whenever it is efficient and appropriate to do so. A time line shall be included for the implementation of each task.
- (5) *Outreach to employees.* The Discharger shall inform employees about the pollutants of concern, potential sources, and how they might be able to help reduce the discharge of these pollutants of concern into the Facility. The Discharger may provide a forum for employees to provide input.
- (6) *Continuation of Public Outreach Program.* The Discharger shall prepare a public outreach program to communicate pollution prevention to its service area. Outreach may include participation in existing community events such as county fairs, initiating new community events such as displays and contests during Pollution Prevention Week, conducting school outreach programs, conducting Plant tours, and providing public information in newspaper articles or advertisements, radio or television stories or spots, newsletters, utility bill inserts, and web site. Information shall be specific to the target audiences. The Discharger shall coordinate with other agencies as appropriate.
- (7) *Discussion of criteria used to measure Pollutant Minimization Program and task effectiveness.* The Discharger shall establish criteria to evaluate the effectiveness of its Pollutant Minimization Program. This section shall discuss the specific criteria used to measure the effectiveness of each of the tasks in sections VI.C.3.b(3), (4), (5), and (6).
- (8) *Documentation of efforts and progress.* This discussion shall detail all of the Discharger's Pollutant Minimization Program activities during the reporting year.

- (9) *Evaluation of Pollutant Minimization Program and task effectiveness.* This Discharger shall use the criteria established in section VI.C.3.b.(7) to evaluate the Program's and tasks' effectiveness.
- (10) *Identification of specific tasks and time schedules for future efforts.* Based on the evaluation, the Discharger shall detail how it intends to continue or change its tasks in order to more effectively reduce the amount of pollutants to the Plant, and subsequently in its effluent.

c. Pollutant Minimization Program for Pollutants with Effluent Limitations

The Discharger shall develop and conduct a Pollutant Minimization Program as further described below when there is evidence that a priority pollutant is present in the effluent above an effluent limitation (e.g., sample results reported as DNQ when the effluent limitation is less than the MDL, sample results from analytical methods more sensitive than those methods required by this Order, presence of whole effluent toxicity, health advisories for fish consumption, results of benthic or aquatic organism tissue sampling) and either:

- (1) A sample result is reported as DNQ and the effluent limitation is less than the RL; or
- (2) A sample result is reported as ND and the effluent limitation is less than the MDL, using SIP definitions in Attachment A and reporting protocols described in the MRP.

d. Pollutant Minimization Program Submittals for Pollutants with Effluent Limitations

If triggered by the reasons in section VI.C.3.c, above, the Discharger's Pollutant Minimization Program shall include, but not be limited to, the following actions and submittals:

- (1) Annual review and semi-annual monitoring of potential sources of the reportable priority pollutants. The Executive Officer may approve alternate measures, such as fish tissue monitoring or other bio-uptake sampling, when it is demonstrated that source monitoring is unlikely to produce useful analytical data;
- (2) Quarterly monitoring for the reportable priority pollutants in the influent to the Facility. The Executive Officer may approve alternative measures when it is demonstrated that influent monitoring is unlikely to produce useful analytical data;
- (3) Submittal of a control strategy designed to proceed toward the goal of maintaining concentrations of the reportable priority pollutants in the effluent at or below the effluent limitation;
- (4) Implementation of appropriate cost-effective control measures for the reportable priority pollutants, consistent with the control strategy; and

- (5) Annual report required by section VI.C.3.b, above, shall specifically address the following items:
 - (a) All Pollutant Minimization Program monitoring results for the previous year;
 - (b) List of potential sources of the reportable priority pollutants;
 - (c) Summary of all actions undertaken pursuant to the control strategy; and
 - (d) Description of actions to be taken in the following year.

4. Special Provisions for POTWs

a. Biosolids Management Practices

- (1) All biosolids shall be disposed of, managed or reused in a municipal solid waste landfill, through land application, as a Class A compost, through a waste to energy facility, or other recognized and approved technology, disposed of in a sludge-only landfill or fired in a sewage sludge incinerator in accordance with 40 CFR Part 503.
- (2) Biosolids treatment, storage and disposal or reuse shall not create a nuisance, such as objectionable odors or flies, or result in groundwater contamination.
- (3) The biosolids treatment and storage site shall have facilities adequate to divert surface runoff from adjacent areas, to protect boundaries of the site from erosion and rising sea levels, and to prevent any conditions that would cause drainage from the materials in the temporary storage site. Adequate protection is defined as protection from at least a 100-year storm and protection from the highest possible tidal stage that may occur.
- (4) Biosolids disposed of in a municipal solid waste landfill shall meet the requirements of 40 CFR Part 258. In the annual self-monitoring report, the Discharger shall include the amount of biosolids disposed and the landfill to which it was sent.
- (5) This Order does not authorize permanent onsite biosolids storage or disposal. A Report of Waste Discharge shall be filed and the site brought into compliance with all applicable regulations prior to commencement of any such activity.

b. Sanitary Sewer Overflows and Sewer System Management Plan

The Discharger's wastewater collection system is part of the facility subject to this Order. As such, the Discharger shall properly operate and maintain its collection system (Attachment D, section I.D). The Discharger shall report any noncompliance (Attachment D, sections V.E.1 and V.E.2) and mitigate any discharge from its collection system in violation of this Order (Attachment D, section I.C).

The General Waste Discharge Requirements for Collection System Agencies (General Collection System WDRs), Order No. 2006-0003 DWQ, has requirements for operation and maintenance of collection systems and for reporting and mitigating sanitary sewer

overflows. While the Discharger must comply with both the General Collection System WDRs and this Order, the General Collection System WDRs more clearly and specifically stipulate requirements for operation and maintenance and for reporting and mitigating sanitary sewer overflows.

Implementation of the General Collection System WDRs requirements for proper operation and maintenance and mitigation of sanitary sewer overflows will satisfy the corresponding federal NPDES requirements specified in Attachment D (as supplemented by Attachment G) of this Order. Following notification and reporting requirements in the General Collection System WDRs will satisfy NPDES reporting requirements specified in Attachment D (as supplemented by Attachment G) of the Order for sanitary sewer overflows from the collection system upstream of the Plant boundaries. Attachments D and G of this Order specify reporting requirements for unauthorized discharges from anywhere within the Facility downstream of the Plant boundaries.

5. Other Special Provisions

a. Specific Tasks to Improve Wet Weather Management and Reduce Blending

The Discharger shall implement the following tasks to improve wet weather management and reduce blending:

Table 8. Specific Tasks to Improve Wet Weather Management and Reduce Blending

Task	Compliance Date
<p>1. Develop and Implement Wet Weather Improvement Plan. The Discharger shall develop a comprehensive Wet Weather Improvement Plan that establishes measurable goals to minimize and eventually eliminate blending due to wet weather events. The plan shall include all feasible alternatives to reduce blending caused by inflow and infiltration during peak flows. The plan shall specify measures to be implemented at the Plant as well as the wastewater collection system, and identify their costs, implementation schedules, and proposed funding mechanisms. At a minimum, the plan shall detail the following activities:</p> <ul style="list-style-type: none"> • Addition of onsite storage and other Plant improvements that are part of the 18-month (June 2012-November 2013), \$12-million Plant Rehabilitation Project; • Completion of projects that are part of the 10-year (2005-2015), \$2-million Sewer Rehabilitation Plan, which encompasses both the Tiburon and Belvedere collection systems; and • Initiation of projects that are part of the 10-year Capital Improvement Plan (2013-2023), including, but not limited to, corrective actions at the 23 problematic sites identified through targeted smoke tests in October 2011. <p>The Discharger shall clearly identify the measures to be undertaken during this Order’s term. The Discharger shall describe the extent to which implementing these measures (at the Plant and in the collection systems) will improve wet weather management. The Discharger shall incorporate feedback, if any, from the Regional Water Board staff and begin implementation of the plan by the date specified.</p>	<p>April 1, 2014</p>
<p>2. Report Progress on Implementing Wet Weather Improvement Plan. The Discharger shall evaluate and report on the implementation and effectiveness of its Wet Weather Improvement Plan annually.</p>	<p>With Annual Self-Monitoring Report due February 1 each year</p>

Task	Compliance Date
<p>3. Consider Expanding Sewer Lateral Requirements. The Discharger shall consider revising its sewer use ordinance (Ordinance 2010-01) to include additional triggers for inspection and repair of sewer laterals of all residential and commercial properties, such as upon change of ownership or other appropriate triggers. The Discharger shall report the status of proposed sewer lateral requirements in its Wet Weather Improvement Plan Progress Report.</p>	<p>With Annual Self-Monitoring Report due February 1 each year</p>
<p>4. Prepare No Feasible Alternatives Analysis (Utility Analysis). If the Discharger seeks to continue to bypass peak wet weather flows around the secondary treatment units based on 40 CFR 122.41(m)(4)(i)(A)-(C), it shall conduct a Utility Analysis that contains all elements described in USEPA’s proposed guidance <i>NPDES Permit Requirements for Peak Wet Weather Discharges from Publicly Owned Treatment Works Treatment Plants Serving Separate Sanitary Sewer Collection Systems</i> (December 2005 or most recent version). The analysis shall account for efforts to reduce infiltration and inflow to the extent that information is available. In addressing these elements, the Utility Analysis shall specifically contain an alternatives analysis for blending reduction to evaluate strategies to further reduce blending through capital improvements or other means. The analysis shall identify all feasible alternatives and explain why infeasible alternatives are infeasible. The Discharger shall select feasible actions based on factors including, but not limited to, the need to blend (considering the effectiveness of the collection system and treatment plant improvement projects), the foreseeable impact on the need to blend, and estimated costs relative to the Discharger’s ability to finance the costs. (One means to assess a community’s ability to fund wet weather improvements is to consult USEPA’s CSO Guidance for Financial Capability Assessment and Schedule Development, EPA Publication Number 832-B-97-004.) The Utility Analysis shall include a timeline for implementation of the feasible actions. The primary purposes of the Utility Analysis are to demonstrate that there are currently no feasible alternatives to blending (i.e., all feasible actions that could have been implemented have been implemented) and to identify all feasible actions that can be implemented within the next permit reissuance cycle.</p>	<p>With Report of Waste Discharge due April 3, 2018</p>
<p>5. Develop and Implement Public Notification Protocol. The Discharger shall develop and implement a public notification protocol to alert the public of any bypass, including blending. The protocol shall provide a mechanism to notify the public within 24 hours of the start of any bypass, and provide an approximate duration and volume for the incident within 48 hours of it ending. The mechanism could involve, for example, website posting or emailing a list of interested parties. The Discharger shall submit the protocol to the Regional Water Board.</p>	<p>December 1, 2013</p>

b. Copper Action Plan

The Discharger shall implement pretreatment, source control, and pollution prevention for copper in accordance with the following tasks and time schedule:

Table 9. Copper Action Plan

Task	Compliance Date
<p>1. Review Potential Copper Sources The Discharger shall submit an inventory of potential copper sources to the Plant.</p>	<p>Completed (submitted with November 2008 Self-Monitoring Report)</p>
<p>2. Implement Copper Control Program The Discharger shall submit a plan for and begin implementation of a program to reduce copper sources identified in Task 1. For publicly owned treatment works, the plan shall consist, at a minimum, of the following elements:</p> <ul style="list-style-type: none"> a. Provide education and outreach to the public (e.g., focus on proper pool and spa maintenance and plumbers’ roles in reducing corrosion). b. If corrosion is determined to be a significant copper source, work cooperatively with local water purveyors to reduce and control water corrosivity, as appropriate, and ensure that local plumbing contractors implement best management practices to reduce corrosion in pipes. c. Educate plumbers, designers, and maintenance contractors for pools and spas to encourage best management practices that minimize copper discharges. 	<p>Completed (submitted with 2008 Annual Pollution Prevention Report)</p>
<p>3. Implement Additional Measures If the Regional Water Board notifies the Discharger that the three-year rolling mean dissolved copper concentration of the receiving water exceeds 2.2 µg/L, then within 90 days of the notification, the Discharger shall evaluate its effluent copper concentration trend, and if it is increasing, develop and begin implementation of additional measures to control copper discharges. The Discharger shall report on the progress and effectiveness of actions taken, together with a schedule for actions to be taken in the next 12 months.</p>	<p>90 days following notification</p>
<p>4. Undertake Studies to Reduce Copper Pollutant Impact Uncertainties The Discharger shall submit an updated study plan and schedule to conduct, or cause to be conducted, technical studies to investigate possible copper sediment toxicity and technical studies to investigate sublethal effects on salmonids. Specifically, the Discharger shall include the manner in which the above will be accomplished and describe the studies to be performed with an implementation schedule. To satisfy this requirement, dischargers may collaborate and conduct these studies as a group.</p>	<p>Completed (submitted as part of Bay Area Clean Water Agencies’ annual report of NPDES permit compliance activities)</p>
<p>5. Report Status of Copper Control Program The Discharger shall submit an annual report documenting copper control program implementation and addressing the effectiveness of the actions taken, including any additional copper controls required by Task 3, above, together with a schedule for actions to be taken in the next 12 months. Additionally, the Discharger shall report the findings and results of the studies completed, planned, or in progress under Task 4. Regarding the Task 4 studies, dischargers may collaborate and provide this information in a single report to satisfy this requirement for an entire group.</p>	<p>With annual pollution prevention report due February 28 each year</p>

c. Cyanide Action Plan

The Discharger shall implement monitoring and surveillance, pretreatment, source control and pollution prevention for cyanide in accordance with the following tasks and time schedule:

Table 10. Cyanide Action Plan

Task	Compliance Date
<p>1. Review Potential Cyanide Sources The Discharger shall submit an inventory of potential cyanide sources to the Plant. If no cyanide sources are identified, Tasks 2 and 3 are not required, unless the Discharger receives a request to discharge detectable levels of cyanide to the sewer. If so, the Discharger shall notify the Executive Officer and implement Tasks 2 and 3.</p>	<p>Completed (submitted September 10, 2008; no sources identified)</p>
<p>2. Implement Cyanide Control Program The Discharger shall submit a plan and begin implementation of a program to minimize cyanide discharges to its treatment plant consisting, at a minimum, of the following elements:</p> <ul style="list-style-type: none"> a. Inspect each potential source to assess the need to include that contributing source in the control program. b. Inspect contributing sources included in the control program annually. Inspection elements may be based on USEPA guidance, such as Industrial User Inspection and Sampling Manual for POTWs (EPA 831-B-94-01). c. Develop and distribute educational materials to contributing sources and potential contributing sources regarding the need to prevent cyanide discharges. d. Prepare an emergency monitoring and response plan to be implemented if a significant cyanide discharge occurs. <p>For purposes of this Order, a “significant cyanide discharge” is occurring if the Plant’s influent cyanide concentration exceeds 30 µg/L.</p>	<p>Completed (submitted with 2008 Annual Pollution Prevention Report)</p>
<p>3. Implement Additional Cyanide Control Measures If the Regional Water Board notifies the Discharger that ambient monitoring shows cyanide concentrations are 1.0 µg/L or higher in the main body of San Francisco Bay, then within 90 days of the notification, the Discharger shall commence actions to identify and abate cyanide sources responsible for the elevated ambient concentrations, and shall report on the progress and effectiveness of actions taken, together with a schedule for actions to be taken in the next 12 months.</p>	<p>90 days following notification</p>
<p>4. Report Status of Cyanide Control Program The Discharger shall submit an annual report documenting cyanide control program implementation and addressing the effectiveness of actions taken, including any additional cyanide controls required by Task 3, above, together with a schedule for actions to be taken in the next 12 months.</p>	<p>With annual pollution prevention report due February 28 each year</p>

VII.COMPLIANCE DETERMINATION

Compliance with effluent limitations for priority pollutants shall be determined using sample reporting protocols defined in Attachment A -- Definitions, the MRP, Fact Sheet section VI, and the Regional Standard Provisions (Attachment G). For purposes of reporting and administrative enforcement by the Regional and State Water Boards, the Discharger shall be deemed out of compliance with effluent limitations if the concentration of the priority pollutant in the monitoring sample is greater than the effluent limitation and greater than or equal to the reporting level (RL).

ATTACHMENT A – DEFINITIONS

Arithmetic Mean (μ)

Also called the average, is the sum of measured values divided by the number of samples. For ambient water concentrations, the arithmetic mean is calculated as follows:

$$\text{Arithmetic mean} = \mu = \Sigma x / n \quad \text{where: } \Sigma x \text{ is the sum of the measured ambient water concentrations, and } n \text{ is the number of samples.}$$

Average Monthly Effluent Limitation (AMEL)

The highest allowable average of daily discharges over a calendar month, calculated as the sum of all daily discharges measured during a calendar month divided by the number of daily discharges measured during that month.

Average Weekly Effluent Limitation (AWEL)

The highest allowable average of daily discharges over a calendar week (Sunday through Saturday), calculated as the sum of all daily discharges measured during a calendar week divided by the number of daily discharges measured during that week.

Bioaccumulative

Those substances taken up by an organism from its surrounding medium through gill membranes, epithelial tissue, or from food and subsequently concentrated and retained in the body of the organism.

Coefficient of Variation (CV)

CV is a measure of the data variability and is calculated as the estimated standard deviation divided by the arithmetic mean of the observed values.

Daily Discharge

Daily Discharge is defined as either: (1) the total mass of the constituent discharged over the calendar day (12:00 am through 11:59 pm) or any 24-hour period that reasonably represents a calendar day for purposes of sampling (as specified in this Order), for a constituent with limitations expressed in units of mass or; (2) the unweighted arithmetic mean measurement of the constituent over the day for a constituent with limitations expressed in other units of measurement (e.g., concentration).

The daily discharge may be determined by the analytical results of a composite sample taken over the course of one day (a calendar day or other 24-hour period defined as a day) or by the arithmetic mean of analytical results from one or more grab samples taken over the course of the day.

For composite sampling, if 1 day is defined as a 24-hour period other than a calendar day, the analytical result for the 24-hour period will be considered as the result for the calendar day in which the 24-hour period ends.

Detected, but Not Quantified (DNQ)

DNQ are those sample results less than the RL, but greater than or equal to the laboratory's MDL.

Dilution Credit

Dilution Credit is the amount of dilution granted to a discharge in the calculation of a water quality-based effluent limitation, based on the allowance of a specified mixing zone. It is calculated from the dilution ratio or determined through conducting a mixing zone study or modeling of the discharge and receiving water.

Effluent Concentration Allowance (ECA)

ECA is a value derived from the water quality criterion/objective, dilution credit, and ambient background concentration that is used, in conjunction with the coefficient of variation for the effluent monitoring data, to calculate a long-term average (LTA) discharge concentration. The ECA has the same meaning as waste load allocation (WLA) as used in USEPA guidance (Technical Support Document For Water Quality-based Toxics Control, March 1991, second printing, EPA/505/2-90-001).

Enclosed Bays

Enclosed Bays means indentations along the coast that enclose an area of oceanic water within distinct headlands or harbor works. Enclosed bays include all bays where the narrowest distance between the headlands or outermost harbor works is less than 75 percent of the greatest dimension of the enclosed portion of San Francisco Bay. Enclosed bays include, but are not limited to, Humboldt Bay, Bodega Harbor, Tomales Bay, Drake’s Estero, San Francisco Bay, Morro Bay, Los Angeles-Long Beach Harbor, Upper and Lower Newport Bay, Mission Bay, and San Diego Bay. Enclosed bays do not include inland surface waters or ocean waters.

Estimated Chemical Concentration

The estimated chemical concentration that results from the confirmed detection of the substance by the analytical method below the ML value.

Estuaries

Estuaries means waters, including coastal lagoons, located at the mouths of streams that serve as areas of mixing for fresh and ocean waters. Coastal lagoons and mouths of streams that are temporarily separated from the ocean by sandbars shall be considered estuaries. Estuarine waters shall be considered to extend from a bay or the open ocean to a point upstream where there is no significant mixing of fresh water and seawater. Estuarine waters include, but are not limited to, the Sacramento-San Joaquin Delta, as defined in California Water Code section 12220, Suisun Bay, Carquinez Strait downstream to the Carquinez Bridge, and appropriate areas of the Smith, Mad, Eel, Noyo, Russian, Klamath, San Diego, and Otay rivers. Estuaries do not include inland surface waters or ocean waters.

Inland Surface Waters

All surface waters of the State that do not include the ocean, enclosed bays, or estuaries.

Instantaneous Maximum Effluent Limitation

The highest allowable value for any single grab sample or aliquot (i.e., each grab sample or aliquot is independently compared to the instantaneous maximum limitation).

Instantaneous Minimum Effluent Limitation

The lowest allowable value for any single grab sample or aliquot (i.e., each grab sample or aliquot is independently compared to the instantaneous minimum limitation).

Maximum Daily Effluent Limitation (MDEL)

The highest allowable daily discharge of a pollutant, over a calendar day (or 24-hour period). For pollutants with limitations expressed in units of mass, the daily discharge is calculated as the total mass of the pollutant discharged over the day. For pollutants with limitations expressed in other units of measurement, the daily discharge is calculated as the arithmetic mean measurement of the pollutant over the day.

Median

The middle measurement in a set of data. The median of a set of data is found by first arranging the measurements in order of magnitude (either increasing or decreasing order). If the number of measurements (n) is odd, then the median = $X_{(n+1)/2}$. If n is even, then the median = $(X_{n/2} + X_{(n/2)+1})/2$ (i.e., the midpoint between the $n/2$ and $n/2+1$).

Method Detection Limit (MDL)

MDL is the minimum concentration of a substance that can be measured and reported with 99 percent confidence that the analyte concentration is greater than zero, as defined in title 40 of the Code of Federal Regulations (40 CFR), Part 136, Attachment B, revised as of July 3, 1999.

Minimum Level (ML)

ML is the concentration at which the entire analytical system must give a recognizable signal and acceptable calibration point. The ML is the concentration in a sample that is equivalent to the concentration of the lowest calibration standard analyzed by a specific analytical procedure, assuming that all the method specified sample weights, volumes, and processing steps have been followed.

Mixing Zone

Mixing Zone is a limited volume of receiving water that is allocated for mixing with a wastewater discharge where water quality criteria can be exceeded without causing adverse effects to the overall water body.

Not Detected (ND)

Sample results less than the laboratory's MDL.

Ocean Waters

The territorial marine waters of the State as defined by California law to the extent these waters are outside of enclosed bays, estuaries, and coastal lagoons. Discharges to ocean waters are regulated in accordance with the State Water Board's California Ocean Plan.

Persistent Pollutants

Persistent pollutants are substances for which degradation or decomposition in the environment is nonexistent or very slow.

Pollutant Minimization Program (PMP)

PMP means waste minimization and pollution prevention actions that include, but are not limited to, product substitution, waste stream recycling, alternative waste management methods, and education of the public and businesses. The goal of the PMP shall be to reduce all potential sources of a priority pollutant(s) through pollutant minimization (control) strategies, including pollution prevention measures as appropriate, to maintain the effluent concentration at or below the water quality-based effluent limitation. Pollution prevention measures may be particularly appropriate for persistent bioaccumulative priority pollutants where there is evidence that beneficial uses are being impacted. The Regional Water Board may consider cost effectiveness when establishing the requirements of a PMP. The completion and implementation of a Pollution Prevention Plan, if required pursuant to California Water Code section 13263.3(d), shall be considered to fulfill the PMP requirements.

Pollution Prevention

Pollution Prevention means any action that causes a net reduction in the use or generation of a hazardous substance or other pollutant that is discharged into water and includes, but is not limited to, input

change, operational improvement, production process change, and product reformulation (as defined in California Water Code section 13263.3). Pollution prevention does not include actions that merely shift a pollutant in wastewater from one environmental medium to another environmental medium, unless clear environmental benefits of such an approach are identified to the satisfaction of the State or Regional Water Board.

Reporting Level (RL)

RL is the ML (and its associated analytical method) chosen by the Discharger for reporting and compliance determination from the MLs included in this Order. The MLs included in this Order correspond to approved analytical methods for reporting a sample result that are selected by the Regional Water Board either from Appendix 4 of the SIP in accordance with section 2.4.2 of the SIP or established in accordance with section 2.4.3 of the SIP. The ML is based on the proper application of method-based analytical procedures for sample preparation and the absence of any matrix interferences. Other factors may be applied to the ML depending on the specific sample preparation steps employed. For example, the treatment typically applied in cases where there are matrix-effects is to dilute the sample or sample aliquot by a factor of ten. In such cases, this additional factor must be applied to the ML in the computation of the RL.

Satellite Collection System

The portion, if any, of a sanitary sewer system owned or operated by a different public agency than the agency that owns and operates the wastewater treatment facility that the sewer system is tributary to.

Source of Drinking Water

Any water designated as municipal or domestic supply (MUN) in a Regional Water Board Basin Plan.

Standard Deviation (σ)

Standard Deviation is a measure of variability that is calculated as follows:

$$\sigma = (\sum[(x - \mu)^2]/(n - 1))^{0.5}$$

where:

x is the observed value;

μ is the arithmetic mean of the observed values; and

n is the number of samples.

Toxicity Reduction Evaluation (TRE)

TRE is a study conducted in a step-wise process designed to identify the causative agents of effluent or ambient toxicity, isolate the sources of toxicity, evaluate the effectiveness of toxicity control options, and then confirm the reduction in toxicity. The first steps of the TRE consist of the collection of data relevant to the toxicity, including additional toxicity testing, and an evaluation of facility operations and maintenance practices, and best management practices. A Toxicity Identification Evaluation (TIE) may be required as part of the TRE, if appropriate. (A TIE is a set of procedures to identify the specific chemical(s) responsible for toxicity. These procedures are performed in three phases (characterization, identification, and confirmation) using aquatic organism toxicity tests.)

ATTACHMENT B – FACILITY MAP

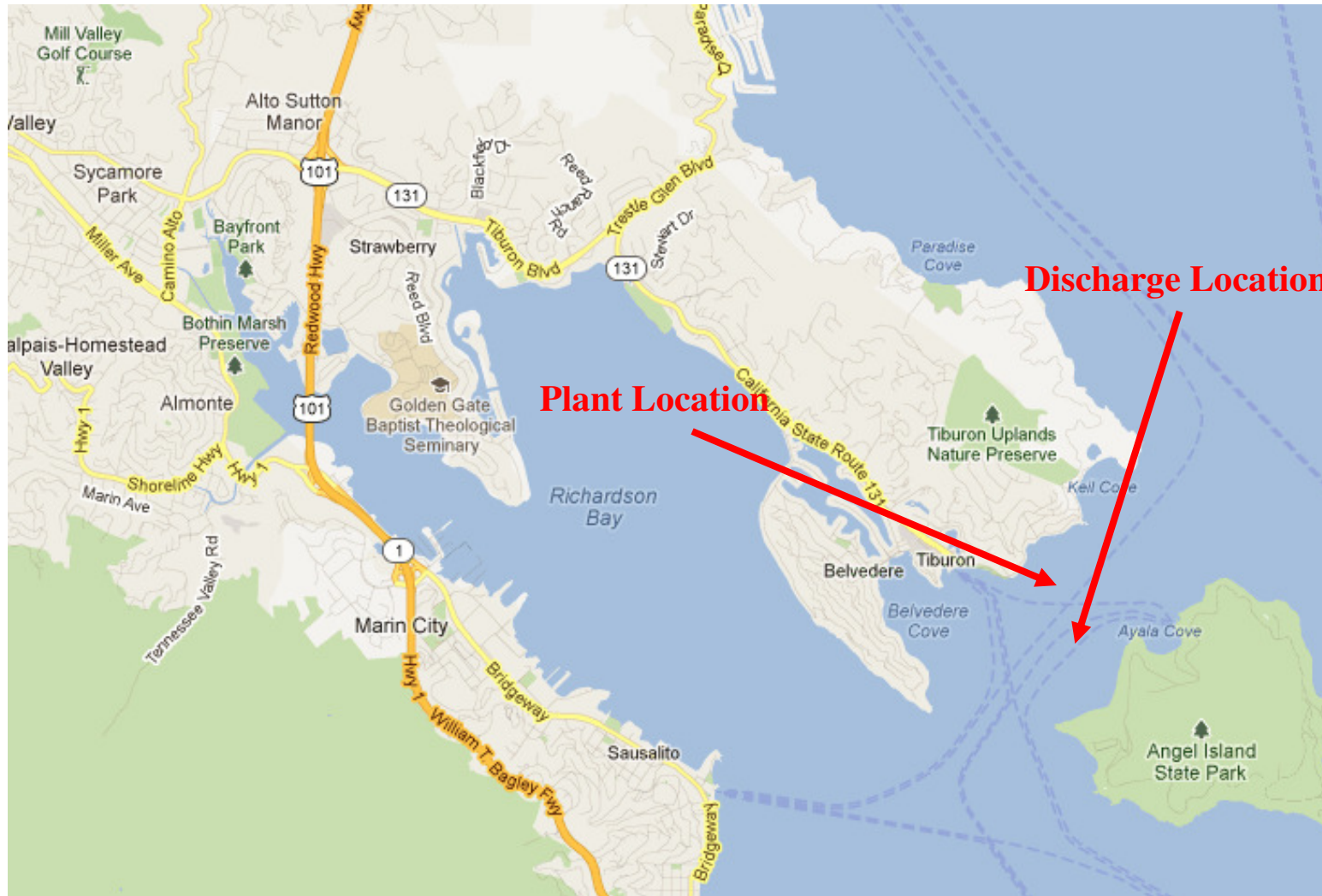

ATTACHMENT C – PROCESS FLOW DIAGRAM

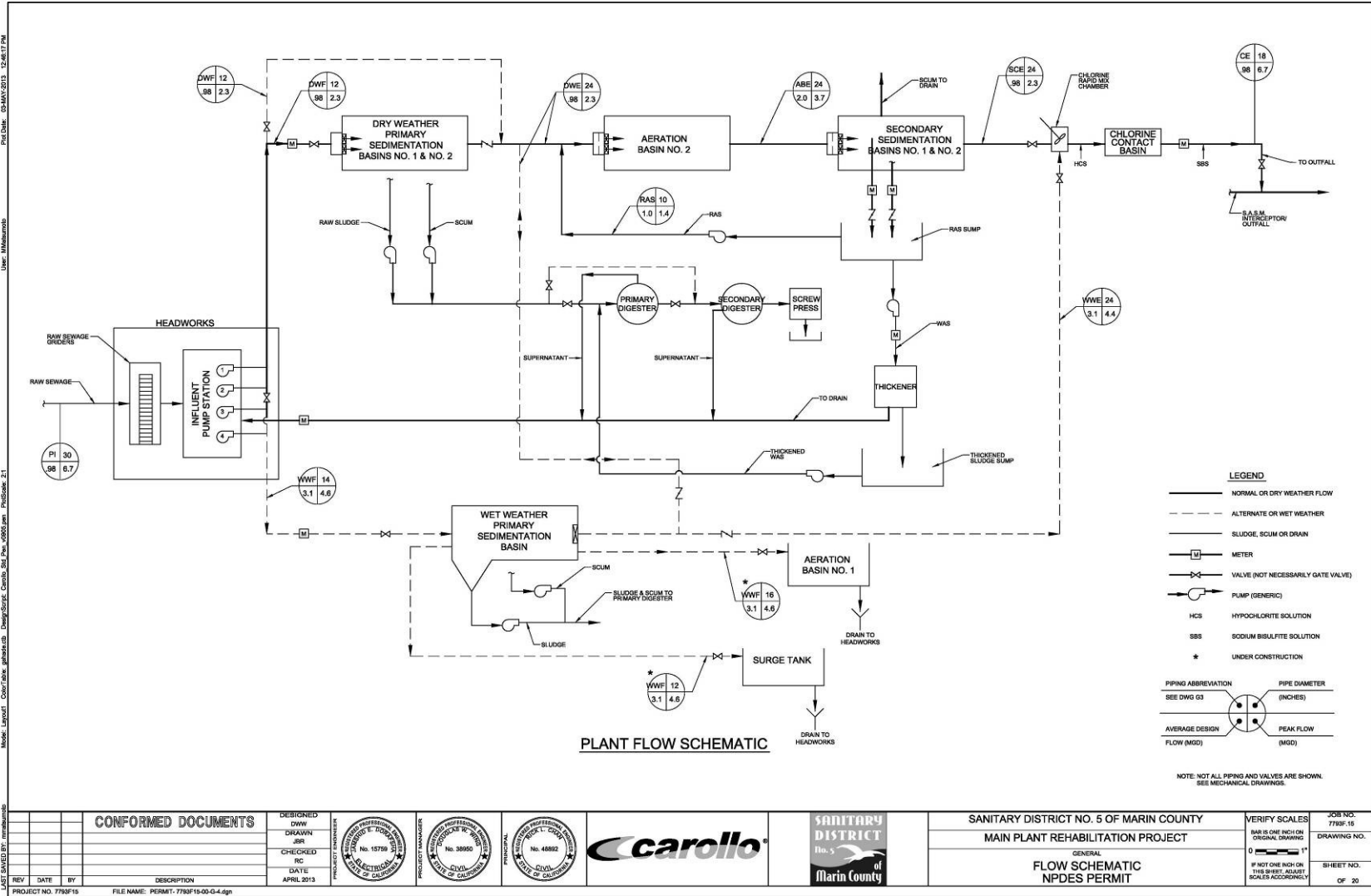

ATTACHMENT D – STANDARD PROVISIONS

I. STANDARD PROVISIONS – PERMIT COMPLIANCE

A. Duty to Comply

1. The Discharger must comply with all of the conditions of this Order. Any noncompliance constitutes a violation of the Clean Water Act (CWA) and the California Water Code and is grounds for enforcement action, for permit termination, revocation and reissuance, or modification; or denial of a permit renewal application. (40 CFR 122.41(a)).
2. The Discharger shall comply with effluent standards or prohibitions established under section 307(a) of the CWA for toxic pollutants and with standards for sewage sludge use or disposal established under section 405(d) of the CWA within the time provided in the regulations that establish these standards or prohibitions, even if this Order has not yet been modified to incorporate the requirement. (40 CFR 122.41(a)(1)).

B. Need to Halt or Reduce Activity Not a Defense

It shall not be a defense for a Discharger in an enforcement action that it would have been necessary to halt or reduce the permitted activity in order to maintain compliance with the conditions of this Order. (40 CFR 122.41(c).)

C. Duty to Mitigate

The Discharger shall take all reasonable steps to minimize or prevent any discharge or sludge use or disposal in violation of this Order that has a reasonable likelihood of adversely affecting human health or the environment. (40 CFR 122.41(d).)

D. Proper Operation and Maintenance

The Discharger shall at all times properly operate and maintain all facilities and systems of treatment and control (and related appurtenances) which are installed or used by the Discharger to achieve compliance with the conditions of this Order. Proper operation and maintenance also includes adequate laboratory controls and appropriate quality assurance procedures. This provision requires the operation of backup or auxiliary facilities or similar systems that are installed by a Discharger only when necessary to achieve compliance with the conditions of this Order (40 CFR 122.41(e)).

E. Property Rights

1. This Order does not convey any property rights of any sort or any exclusive privileges. (40 CFR 122.41(g).)
2. The issuance of this Order does not authorize any injury to persons or property or invasion of other private rights, or any infringement of state or local law or regulations. (40 CFR 122.5(c).)

F. Inspection and Entry

The Discharger shall allow the Regional Water Board, State Water Board, USEPA, and/or their authorized representatives (including an authorized contractor acting as their representative), upon the presentation of credentials and other documents, as may be required by law, to (40 CFR 122.41(i); Water Code, § 13383):

1. Enter upon the Discharger's premises where a regulated facility or activity is located or conducted, or where records are kept under the conditions of this Order (40 CFR 122.41(i)(1));
2. Have access to and copy, at reasonable times, any records that must be kept under the conditions of this Order (40 CFR 122.41(i)(2));
3. Inspect and photograph, at reasonable times, any facilities, equipment (including monitoring and control equipment), practices, or operations regulated or required under this Order (40 CFR 122.41(i)(3)); and
4. Sample or monitor, at reasonable times, for the purposes of assuring Order compliance or as otherwise authorized by the CWA or the Water Code, any substances or parameters at any location. (40 CFR 122.41(i)(4).)

G. Bypass

1. Definitions
 - a. “Bypass” means the intentional diversion of waste streams from any portion of a treatment facility. (40 CFR 122.41(m)(1)(i).)
 - b. “Severe property damage” means substantial physical damage to property, damage to the treatment facilities, which causes them to become inoperable, or substantial and permanent loss of natural resources that can reasonably be expected to occur in the absence of a bypass. Severe property damage does not mean economic loss caused by delays in production. (40 CFR 122.41(m)(1)(ii).)
2. Bypass not exceeding limitations. The Discharger may allow any bypass to occur which does not cause exceedances of effluent limitations, but only if it is for essential maintenance to assure efficient operation. These bypasses are not subject to the provisions listed in Standard Provisions – Permit Compliance I.G.3, I.G.4, and I.G.5 below. (40 CFR 122.41(m)(2).)
3. Prohibition of bypass. Bypass is prohibited, and the Regional Water Board may take enforcement action against a Discharger for bypass, unless (40 CFR 122.41(m)(4)(i)):
 - a. Bypass was unavoidable to prevent loss of life, personal injury, or severe property damage (40 CFR 122.41(m)(4)(i)(A));
 - b. There were no feasible alternatives to the bypass, such as the use of auxiliary treatment facilities, retention of untreated wastes, or maintenance during normal periods of equipment downtime. This condition is not satisfied if adequate back-up equipment should have been installed in the exercise of reasonable engineering judgment to prevent

- a bypass that occurred during normal periods of equipment downtime or preventive maintenance (40 CFR 122.41(m)(4)(i)(B)); and
- c. The Discharger submitted notice to the Regional Water Board as required under Standard Provisions – Permit Compliance I.G.5 below. (40 CFR 122.41(m)(4)(i)(C).)
4. The Regional Water Board may approve an anticipated bypass, after considering its adverse effects, if the Regional Water Board determines that it will meet the three conditions listed in Standard Provisions – Permit Compliance I.G.3 above. (40 CFR 122.41(m)(4)(ii).)
 5. Notice
 - a. Anticipated bypass. If the Discharger knows in advance of the need for a bypass, it shall submit a notice, if possible at least 10 days before the date of the bypass. (40 CFR 122.41(m)(3)(i).)
 - b. Unanticipated bypass. The Discharger shall submit notice of an unanticipated bypass as required in Standard Provisions - Reporting V.E below (24-hour notice). (40 CFR 122.41(m)(3)(ii).)

H. Upset

Upset means an exceptional incident in which there is unintentional and temporary noncompliance with technology-based permit effluent limitations because of factors beyond the reasonable control of the Discharger. An upset does not include noncompliance to the extent caused by operational error, improperly designed treatment facilities, inadequate treatment facilities, lack of preventive maintenance, or careless or improper operation. (40 CFR 122.41(n)(1).)

1. Effect of an upset. An upset constitutes an affirmative defense to an action brought for noncompliance with such technology-based permit effluent limitations if the requirements of Standard Provisions – Permit Compliance I.H.2 below are met. No determination made during administrative review of claims that noncompliance was caused by upset, and before an action for noncompliance, is final administrative action subject to judicial review. (40 CFR 122.41(n)(2).)
2. Conditions necessary for a demonstration of upset. A Discharger who wishes to establish the affirmative defense of upset shall demonstrate, through properly signed, contemporaneous operating logs or other relevant evidence that (40 CFR 122.41(n)(3)):
 - a. An upset occurred and that the Discharger can identify the cause(s) of the upset (40 CFR 122.41(n)(3)(i));
 - b. The permitted facility was, at the time, being properly operated (40 CFR 122.41(n)(3)(ii));
 - c. The Discharger submitted notice of the upset as required in Standard Provisions – Reporting V.E.2.b below (24-hour notice) (40 CFR 122.41(n)(3)(iii)); and
 - d. The Discharger complied with any remedial measures required under Standard Provisions – Permit Compliance I.C above. (40 CFR 122.41(n)(3)(iv).)

3. Burden of proof. In any enforcement proceeding, the Discharger seeking to establish the occurrence of an upset has the burden of proof. (40 CFR 122.41(n)(4).)

II. STANDARD PROVISIONS – PERMIT ACTION

A. General

This Order may be modified, revoked and reissued, or terminated for cause. The filing of a request by the Discharger for modification, revocation and reissuance, or termination, or a notification of planned changes or anticipated noncompliance does not stay any Order condition. (40 CFR 122.41(f).)

B. Duty to Reapply

If the Discharger wishes to continue an activity regulated by this Order after the expiration date of this Order, the Discharger must apply for and obtain a new permit. (40 CFR 122.41(b).)

C. Transfers

This Order is not transferable to any person except after notice to the Regional Water Board. The Regional Water Board may require modification or revocation and reissuance of this Order to change the name of the Discharger and incorporate such other requirements as may be necessary under the CWA and the Water Code. (40 CFR 122.41(l)(3); 122.61.)

III. STANDARD PROVISIONS – MONITORING

- A. Samples and measurements taken for the purpose of monitoring shall be representative of the monitored activity. (40 CFR 122.41(j)(1).)
- B. Monitoring results must be conducted according to test procedures under Part 136 or, in the case of sludge use or disposal, approved under Part 136 unless otherwise specified in Part 503 unless other test procedures have been specified in this Order. (40 CFR 122.41(j)(4); 122.44(i)(1)(iv).)

IV. STANDARD PROVISIONS – RECORDS

- A. Except for records of monitoring information required by this Order related to the Discharger's sewage sludge use and disposal activities, which shall be retained for a period of at least five years (or longer as required by Part 503), the Discharger shall retain records of all monitoring information, including all calibration and maintenance records and all original strip chart recordings for continuous monitoring instrumentation, copies of all reports required by this Order, and records of all data used to complete the application for this Order, for a period of at least three (3) years from the date of the sample, measurement, report or application. This period may be extended by request of the Regional Water Board Executive Officer at any time. (40 CFR 122.41(j)(2).)
- B. Records of monitoring information shall include:
 1. The date, exact place, and time of sampling or measurements (40 CFR 122.41(j)(3)(i));
 2. The individual(s) who performed the sampling or measurements (40 CFR 122.41(j)(3)(ii));
 3. The date(s) analyses were performed (40 CFR 122.41(j)(3)(iii));

4. The individual(s) who performed the analyses (40 CFR 122.41(j)(3)(iv));
5. The analytical techniques or methods used (40 CFR 122.41(j)(3)(v)); and
6. The results of such analyses. (40 CFR 122.41(j)(3)(vi).)

C. Claims of confidentiality for the following information will be denied (40 CFR 122.7(b)):

1. The name and address of any permit applicant or Discharger (40 CFR 122.7(b)(1)); and
2. Permit applications and attachments, permits and effluent data. (40 CFR 122.7(b)(2).)

V. STANDARD PROVISIONS – REPORTING

A. Duty to Provide Information

The Discharger shall furnish to the Regional Water Board, State Water Board, or USEPA within a reasonable time, any information which the Regional Water Board, State Water Board, or USEPA may request to determine whether cause exists for modifying, revoking and reissuing, or terminating this Order or to determine compliance with this Order. Upon request, the Discharger shall also furnish to the Regional Water Board, State Water Board, or USEPA copies of records required to be kept by this Order. (40 CFR 122.41(h); Wat. Code, § 13267.)

B. Signatory and Certification Requirements

1. All applications, reports, or information submitted to the Regional Water Board, State Water Board, and/or USEPA shall be signed and certified in accordance with Standard Provisions – Reporting V.B.2, V.B.3, V.B.4, and V.B.5 below. (40 CFR 122.41(k).)
2. All permit applications shall be signed by either a principal executive officer or ranking elected official. For purposes of this provision, a principal executive officer of a federal agency includes: (i) the chief executive officer of the agency, or (ii) a senior executive officer having responsibility for the overall operations of a principal geographic unit of the agency (e.g., Regional Administrators of USEPA). (40 CFR 122.22(a)(3).)
3. All reports required by this Order and other information requested by the Regional Water Board, State Water Board, or USEPA shall be signed by a person described in Standard Provisions – Reporting V.B.2 above, or by a duly authorized representative of that person. A person is a duly authorized representative only if:
 - a. The authorization is made in writing by a person described in Standard Provisions – Reporting V.B.2 above (40 CFR 122.22(b)(1));
 - b. The authorization specifies either an individual or a position having responsibility for the overall operation of the regulated facility or activity such as the position of plant manager, operator of a well or a well field, superintendent, position of equivalent responsibility, or an individual or position having overall responsibility for environmental matters for the company. (A duly authorized representative may thus be either a named individual or any individual occupying a named position.) (40 CFR 122.22(b)(2)); and

- c. The written authorization is submitted to the Regional Water Board and State Water Board. (40 CFR 122.22(b)(3).)
4. If an authorization under Standard Provisions – Reporting V.B.3 above is no longer accurate because a different individual or position has responsibility for the overall operation of the facility, a new authorization satisfying the requirements of Standard Provisions – Reporting V.B.3 above must be submitted to the Regional Water Board and State Water Board prior to or together with any reports, information, or applications, to be signed by an authorized representative. (40 CFR 122.22(c).)
5. Any person signing a document under Standard Provisions – Reporting V.B.2 or V.B.3 above shall make the following certification:

“I certify under penalty of law that this document and all attachments were prepared under my direction or supervision in accordance with a system designed to assure that qualified personnel properly gather and evaluate the information submitted. Based on my inquiry of the person or persons who manage the system or those persons directly responsible for gathering the information, the information submitted is, to the best of my knowledge and belief, true, accurate, and complete. I am aware that there are significant penalties for submitting false information, including the possibility of fine and imprisonment for knowing violations.” (40 CFR 122.22(d).)

C. Monitoring Reports

1. Monitoring results shall be reported at the intervals specified in the Monitoring and Reporting Program (Attachment E) in this Order. (40 CFR 122.22(l)(4).)
2. Monitoring results must be reported on a Discharge Monitoring Report (DMR) form or forms provided or specified by the Regional Water Board or State Water Board for reporting results of monitoring of sludge use or disposal practices. (40 CFR 122.41(l)(4)(i).)
3. If the Discharger monitors any pollutant more frequently than required by this Order using test procedures approved under Part 136 or, in the case of sludge use or disposal, approved under Part 136 unless otherwise specified in Part 503, or as specified in this Order, the results of this monitoring shall be included in the calculation and reporting of the data submitted in the DMR or sludge reporting form specified by the Regional Water Board. (40 CFR 122.41(l)(4)(ii).)
4. Calculations for all limitations, which require averaging of measurements, shall utilize an arithmetic mean unless otherwise specified in this Order. (40 CFR 122.41(l)(4)(iii).)

D. Compliance Schedules

Reports of compliance or noncompliance with, or any progress reports on, interim and final requirements contained in any compliance schedule of this Order, shall be submitted no later than 14 days following each schedule date. (40 CFR 122.41(l)(5).)

E. Twenty-Four Hour Reporting

1. The Discharger shall report any noncompliance that may endanger health or the environment. Any information shall be provided orally within 24 hours from the time the Discharger becomes aware of the circumstances. A written submission shall also be provided within five (5) days of the time the Discharger becomes aware of the circumstances. The written submission shall contain a description of the noncompliance and its cause; the period of noncompliance, including exact dates and times, and if the noncompliance has not been corrected, the anticipated time it is expected to continue; and steps taken or planned to reduce, eliminate, and prevent reoccurrence of the noncompliance. (40 CFR 122.41(l)(6)(i).)
2. The following shall be included as information that must be reported within 24 hours under this paragraph (40 CFR 122.41(l)(6)(ii)):
 - a. Any unanticipated bypass that exceeds any effluent limitation in this Order. (40 CFR 122.41(l)(6)(ii)(A).)
 - b. Any upset that exceeds any effluent limitation in this Order. (40 CFR 122.41(l)(6)(ii)(B).)
3. The Regional Water Board may waive the above-required written report under this provision on a case-by-case basis if an oral report has been received within 24 hours. (40 CFR 122.41(l)(6)(iii).)

F. Planned Changes

The Discharger shall give notice to the Regional Water Board as soon as possible of any planned physical alterations or additions to the permitted facility. Notice is required under this provision only when (40 CFR 122.41(l)(1)):

1. The alteration or addition to a permitted facility may meet one of the criteria for determining whether a facility is a new source in section 122.29(b) (40 CFR 122.41(l)(1)(i)); or
2. The alteration or addition could significantly change the nature or increase the quantity of pollutants discharged. This notification applies to pollutants that are not subject to effluent limitations in this Order. (40 CFR 122.41(l)(1)(ii).)
3. The alteration or addition results in a significant change in the Discharger's sludge use or disposal practices, and such alteration, addition, or change may justify the application of permit conditions that are different from or absent in the existing permit, including notification of additional use or disposal sites not reported during the permit application process or not reported pursuant to an approved land application plan. (40 CFR 122.41(l)(1)(iii).)

G. Anticipated Noncompliance

The Discharger shall give advance notice to the Regional Water Board or State Water Board of any planned changes in the permitted facility or activity that may result in noncompliance with General Order requirements. (40 CFR 122.41(l)(2).)

H. Other Noncompliance

The Discharger shall report all instances of noncompliance not reported under Standard Provisions Reporting V.C, V.D, and V.E above at the time monitoring reports are submitted. The reports shall contain the information listed in Standard Provision – Reporting V.E above. (40 CFR 122.41(l)(7).)

I. Other Information

When the Discharger becomes aware that it failed to submit any relevant facts in a permit application, or submitted incorrect information in a permit application or in any report to the Regional Water Board, State Water Board, or USEPA, the Discharger shall promptly submit such facts or information. (40 CFR 122.41(l)(8).)

VI. STANDARD PROVISIONS – ENFORCEMENT

- A. The Regional Water Board is authorized to enforce the terms of this Order under several provisions of the Water Code, including, but not limited to, sections 13385, 13386, and 13387.

VII. ADDITIONAL PROVISIONS – NOTIFICATION LEVELS

A. Publicly-Owned Treatment Works (POTWs)

All POTWs shall provide adequate notice to the Regional Water Board of the following (40 CFR 122.42(b)):

1. Any new introduction of pollutants into the POTW from an indirect discharger that would be subject to sections 301 or 306 of the CWA if it were directly discharging those pollutants (40 CFR 122.42(b)(1)); and
2. Any substantial change in the volume or character of pollutants being introduced into that POTW by a source introducing pollutants into the POTW at the time of adoption of this Order. (40 CFR 122.42(b)(2).)
3. Adequate notice shall include information on the quality and quantity of effluent introduced into the POTW as well as any anticipated impact of the change on the quantity or quality of effluent to be discharged from the POTW. (40 CFR 122.42(b)(3).)

ATTACHMENT E – MONITORING AND REPORTING PROGRAM

Contents

I. General Monitoring ProvisionsE-2
 II. Monitoring LocationsE-2
 III. Influent Monitoring RequirementsE-2
 IV. Effluent Monitoring RequirementsE-3
 V. Whole Effluent Toxicity Testing RequirementsE-5
 A. Whole Effluent Acute ToxicityE-5
 B. Whole Effluent Chronic ToxicityE-6
 VI. Receiving Water Monitoring Requirements.....E-9
 VII. Other Monitoring RequirementsE-9
 VIII. Reporting RequirementsE-9
 A. General Monitoring and Reporting RequirementsE-9
 B. Self Monitoring Reports (SMRs)E-9
 C. Discharge Monitoring ReportsE-12
 D. Modifications to Attachment G.....E-12

Tables

Table E-1. Monitoring Station LocationsE-2
 Table E-2. Influent Monitoring at INF-001E-2
 Table E-3. Effluent Monitoring at EFF-001 or EFF-001D.....E-3
 Table E-4. Effluent Monitoring at EFF-001B.....E-4
 Table E-5. SMR Reporting for CIWQS.....E-10
 Table E-6. Monitoring Periods and Reporting ScheduleE-11

ATTACHMENT E – MONITORING AND REPORTING PROGRAM (MRP)

NPDES regulations at 40 CFR 122.48 require that all NPDES permits specify monitoring and reporting requirements. CWC sections 13267 and 13383 also authorize the Regional Water Board to require technical and monitoring reports. This MRP establishes monitoring and reporting requirements that implement the federal and State regulations.

I. GENERAL MONITORING PROVISIONS

- A. The Discharger shall comply with this MRP. The Executive Officer may amend this MRP pursuant to 40 CFR 122.62, 122.63, and 124.5. If any discrepancies exist between this MRP and the Regional Standard Provisions (Attachment G), this MRP prevails.
- B. The Discharger shall conduct all monitoring in accordance with Attachment D, section III, as supplemented by Attachment G of this Order. Equivalent test methods must be more sensitive than those specified in 40 CFR 136 and must be specified in the permit.

II. MONITORING LOCATIONS

The Discharger shall establish the following monitoring locations to demonstrate compliance with the effluent limitations, discharge specifications, and other requirements in this Order:

Table E-1. Monitoring Station Locations

Discharge Point Name	Monitoring Location Name	Monitoring Location Description
Influent	INF-001	At any point upstream of the primary sedimentation basins at which all waste tributary to the treatment system is present and preceding any phase of treatment.
Effluent	EFF-001 (formerly EFF-001-S)	At a point following full treatment where all effluent from the Plant is present but prior to combining with discharges from the Sewerage Agency of Southern Marin (e.g., at the end of the chlorine contact tank after dechlorination).
	EFF-001D	At a point after disinfection is complete and prior to dechlorination (e.g., in the chlorine contact tank after full contact time).
	EFF-001B	At a point at which all blended fully-treated and primary-treated effluent is present (may be the same as Monitoring Location EFF-001 or EFF-001D).
Biosolids	BIO-001	Facility biosolids.

III. INFLUENT MONITORING REQUIREMENTS

The Discharger shall monitor Plant influent as follows:

Table E-2. Influent Monitoring at INF-001

Parameter	Units ^[1]	Sample Type ^[2]	Minimum Sampling Frequency ^[3]
Flow ^[4]	MGD	Continuous/D	Continuous/D
Biochemical Oxygen Demand 5-day @ 20°C (BOD ₅)	mg/L	C-24	1/Week
Total Suspended Solids (TSS)	mg/L	C-24	1/Week

Parameter	Units ^[1]	Sample Type ^[2]	Minimum Sampling Frequency ^[3]
Cyanide, Total ^[5]	µg/L	Grab	2/Year

Footnotes:

^[1] Unit Abbreviations:

- MGD = million gallons per day
- mg/L = milligrams per liter
- µg/L = micrograms per liter

^[2] Sampling Type Abbreviations:

- Continuous/D = measured continuously, and recorded and reported daily
- C-24 = 24-hour composite

^[3] Sampling Frequency:

- Continuous/D = measured continuously, and recorded and reported daily
- 1/Week = Once per week
- 2/Year = Twice per year

^[4] Flows shall be monitored continuously and the following shall be reported in monthly self-monitoring reports:

- a. Daily average flow rate (MGD)
- b. Monthly average flow rate (MGD)
- c. Maximum daily flow (MGD)
- d. Minimum daily flow (MGD)

^[5] May be measured as weak acid dissociable cyanide.

IV. EFFLUENT MONITORING REQUIREMENTS

A. Except when blending, the Discharger shall monitor effluent at Monitoring Locations EFF-001 or EFF-001D as follows:

Table E-3. Effluent Monitoring at EFF-001 or EFF-001D

Parameter	Units ^[1]	Sample Type ^[2]	Minimum Sampling Frequency ^[3]
Flow ^[4]	MGD	Continuous	Continuous/D
BOD ₅ ^[5]	mg/L	C-24	1/Week
TSS ^[5]	mg/L	C-24	1/Week
Oil and Grease ^[6]	mg/L	Grab	1/Quarter
pH ^[7]	Standard Units	Continuous	Continuous/D
Total Residual Chlorine ^[8]	mg/L	Grab or Continuous	1/2Hour or Continuous/2H
Total Coliform Bacteria	MPN/100 mL	Grab	1/Week
Enterococcus Bacteria	MPN/100 mL	Grab	5/Month ^[9]
Acute Toxicity ^[10]	% Survival	Flow through	1/Month
Chronic Toxicity ^[11]	TUc	C-24	1/Year
Copper, Total Recoverable ^[12]	µg/L	C-24	1/Month
Cyanide, Total Recoverable ^{[12][13]}	µg/L	Grab	1/Month
Dioxin-TEQ	µg/L	Grab	1/Year
Total Ammonia as N	mg/L	Grab or C-24	1/Month
Standard Observations ^[14]	--	Visual Observation	1/Month

Footnotes:

- [1] **Unit Abbreviations:**
 MGD = million gallons per day
 mg/L = milligrams per liter
 µg/L = micrograms per liter
 MPN/100 mL = most probable number per 100 milliliters
 TUc = chronic toxic units
- [2] **Sampling Type Abbreviations:**
 Continuous = measured continuously
 C-24 = 24-hour composite
 Flow through = continuously pumped sample during duration of toxicity test
- [3] **Sampling Frequency:**
 Continuous/D = measured continuously, and recorded and reported daily
 Continuous/2H = measured continuously, and recorded and reported every two hours
 1/2 Hour = Once every two hours
 1/Week = Once per week
 1/Month = Once per month
 5/Month = Five per month
 1/Quarter = Once per quarter
 1/Year = Once per year
- [4] For effluent flows, the following information shall also be reported monthly:
 Daily: Daily average flow (MGD)
 Monthly: Monthly average flow (MGD)
 Daily: Maximum daily flow (MGD)
 Daily: Minimum daily flow (MGD)
- [5] The percent removal for BOD and TSS shall be reported for each calendar month in accordance with Effluent Limitation IV.A.
- [6] Each oil and grease sampling and analysis event shall be conducted in accordance with USEPA Method 1664.
- [7] If pH is monitored continuously, the minimum and maximum pH values for each day shall be reported in monthly self-monitoring reports.
- [8] Effluent chlorine residual concentrations shall be monitored continuously or, at a minimum every two hours. The Discharger shall report for each day the maximum residual chlorine concentration observed following dechlorination. However, if monitoring continuously, the Discharger shall report for each day the maximum residual chlorine concentration based on discrete readings from the continuous monitoring taken every hour on the hour. The Discharger shall retain continuous monitoring readings for at least three years. The Regional Water Board reserves the right to use all other continuous monitoring data for discretionary enforcement.
- [9] If after three months the Discharger has demonstrated full compliance with this enterococcus effluent limitation, the minimum monitoring frequency shall be reduced to four times per year. The four samples shall be collected in different calendar months during the higher recreational water contact season (June to October). If the enterococcus effluent limitation is later exceeded, the Discharger shall conduct 5/Month accelerated sampling for at least three consecutive months. If full compliance is demonstrated after the three-month period, the Discharger may return to the 4/Year sampling frequency.
- [10] Test shall be performed and reported in accordance with the Acute Toxicity Requirements specified in Section V.A of this MRP.
- [11] Test shall be performed and reported in accordance with the Chronic Toxicity Requirements specified in Section V.B of this MRP.
- [12] As total recoverable metal.
- [13] Compliance may be demonstrated by measurement of weak acid dissociable cyanide.
- [14] As described in Attachment G, section III.C.2.

B. During blending events, the Discharger shall monitor discharges of treated wastewater from the Plant at Monitoring Location EFF-001B as follows:

Table E-4. Effluent Monitoring at EFF-001B

Parameter	Units ^[1]	Sample Type ^[2]	Minimum Sampling Frequency ^[3]
Flow ^[4]	MGD	Continuous	Continuous/D
Volume of partially-treated wastewater ^[4]	MG	Calculated	1/Blending Event
Duration of Blending Event ^[5]	hours	Calculated	1/Blending Event
TSS	mg/L	C-24	1/Day
Total Coliform Bacteria	MPN/100 mL	Grab	1/Day
Enterococcus Bacteria	MPN/100 mL	Grab	1/Day

Parameter	Units ^[1]	Sample Type ^[2]	Minimum Sampling Frequency ^[3]
BOD ₅	mg/L	Grab or C-24	1/Year ^[6]
pH ^[7]	standard units	Grab or Continuous	1/Year ^[6]
Total Residual Chlorine ^[8]	mg/L	Grab or Continuous	1/Year ^[6]
Total Ammonia as Nitrogen	mg/L as N	Grab or C-24	1/Year ^[6]
Copper, Total Recoverable ^[9]	µg/L	Grab or C-24	1/Year ^[6]
Cyanide, Total Recoverable ^[10]	µg/L	Grab or C-24	1/Year ^[6]

Footnotes:^[1] Unit Abbreviations:

- MGD = million gallons per day
 MG = million gallons
 mg/L = milligrams per liter
 mg/L as N = milligrams per liter as nitrogen
 MPN/100 mL = most probable number per 100 milliliters
 µg/L = micrograms per liter

^[2] Sample Type:

- C-24 = 24-hour composite

^[3] Sampling Frequency:

- Continuous/D = measured continuously, and recorded and reported daily
 1/Day = Once per day
 1/Blending Event = Once per blending event

^[4] “Flow” means the total volume of blended water discharged. “Volume of partially-treated wastewater” means the total volume of wastewater that bypassed secondary treatment.

^[5] For each blending event, report the date and time each event starts and ends.

^[6] If a TSS sample collected on the same day exceeds 45 mg/L, the frequency shall be once per day.

^[7] If pH is monitored continuously, the minimum and maximum pH values for each day shall be reported in monthly Self-Monitoring Reports.

^[8] Effluent chlorine residual concentrations shall be monitored continuously or, at a minimum, every hour. The Discharger shall report for each day the maximum residual chlorine concentration observed following dechlorination. However, if monitoring continuously, the Discharger shall report for each day the maximum residual chlorine concentration based only on discrete readings from the continuous monitoring taken every hour on the hour. The Discharger shall retain continuous monitoring readings for at least three years. The Regional Water Board reserves the right to use all other continuous monitoring data for discretionary enforcement.

^[9] As total recoverable metal.

^[10] Compliance may be demonstrated by measurement of weak acid dissociable cyanide.

V. WHOLE EFFLUENT TOXICITY TESTING REQUIREMENTS

The Discharger shall monitor whole effluent acute and chronic toxicity in samples of final secondary effluent at Monitoring Location EFF-001 as follows:

A. Whole Effluent Acute Toxicity

1. Compliance with the acute toxicity effluent limitations of this Order shall be evaluated by measuring survival of test organisms exposed to 96-hour continuous flow-through bioassays at Monitoring Location EFF-001.
2. Test organisms shall be the fathead minnow (*Pimephales promelas*). The Executive Officer may specify a more sensitive organism or, if testing a particular organism proves unworkable, the most sensitive organism available.

3. All bioassays shall be performed according to the most up-to-date protocols in 40 CFR 136, currently *Methods for Measuring the Acute Toxicity of Effluents and Receiving Water to Freshwater and Marine Organisms*, 5th Edition.
4. If the Discharger demonstrates that specific identifiable substances in the discharge are rapidly rendered harmless upon discharge to the receiving water, compliance with the acute toxicity limit may be determined after the test samples are adjusted to remove the influence of those substances. Written approval from the Executive Officer must be obtained to authorize such an adjustment.
5. The sample shall be taken from secondary treated effluent after dechlorination. Monitoring of the bioassay water shall include, on a daily basis, the following parameters: pH, dissolved oxygen, ammonia (if toxicity is observed), temperature, hardness, and alkalinity. These results shall be reported. If a violation of acute toxicity requirements occurs, the bioassay test shall be repeated with new fish as soon as practical and shall be repeated until a test fish survival rate of 90 percent or greater is observed. If the control fish survival rate is less than 90 percent, the bioassay test shall be restarted with new fish and shall continue as soon as practical until an acceptable test is completed (i.e., control fish survival rate is 90 percent or greater).

B. Whole Effluent Chronic Toxicity

1. Chronic Toxicity Monitoring Requirements

- a. **Sampling.** The Discharger shall collect 24-hour composite samples of the effluent at Monitoring Location EFF-001 for critical life stage toxicity testing as indicated below. For toxicity tests requiring renewals, 24-hour composite samples collected on consecutive days are required.
- b. **Test Species.** The test species shall be *Americamysis bahia*. The Discharger shall conduct a screening chronic toxicity test as described in Appendix E-1 following any significant change in the nature of the effluent or prior to application for permit reissuance. The most sensitive species shall be used thereafter for routine chronic toxicity monitoring. The Executive Officer may authorize a change to another test species if the Discharger's chronic toxicity screening data suggest that another test species is more sensitive to the discharge.
- c. **Frequency.** The frequency of routine and accelerated chronic toxicity monitoring shall be as specified below:
 - (1) Monitor routinely once a year.
 - (2) Accelerate monitoring to *monthly* after exceeding a single sample maximum of 10 TU_c ¹. The Executive Officer may specify a different frequency for accelerated monitoring based on the TU_c results.

¹ A TU_c equals 100 divided by the no observable effect level (NOEL). The NOEL is determined from IC_{25} , EC_{25} , or NOEC values. These terms, their usage, and other chronic toxicity monitoring program requirements are defined in the MRP and Appendix E-1.

- (3) Return to routine monitoring if accelerated monitoring does not exceed either “trigger” in (2), above.
- (4) If accelerated monitoring confirms consistent toxicity in excess of either “trigger” in (2), above, continue accelerated monitoring and initiate toxicity reduction evaluation (TRE) procedures in accordance with section V.B.3, below.
- (5) Return to routine monitoring after implementing appropriate elements of the TRE, and either the toxicity drops below both “triggers” in (2), above, or, based on the TRE results, the Executive Officer authorizes a return to routine monitoring.

Monitoring conducted pursuant to a TRE shall satisfy the requirements for routine and accelerated monitoring while the TRE investigation is underway.

- d. Methodology.** Sample collection, handling, and preservation shall be in accordance with USEPA protocols. In addition, bioassays shall be conducted in compliance with the most recently promulgated test methods, as shown in Appendix E-1. These are *Short-Term Methods for Estimating the Chronic Toxicity of Effluents and Receiving Waters to Marine and Estuarine Organisms*, currently fourth Edition (EPA-821-R-02-013). If these protocols prove unworkable, the Executive Officer and the Environmental Laboratory Accreditation Program may grant exceptions in writing upon the Discharger’s request with justification. If the Discharger demonstrates that specific identifiable substances in the discharge are rapidly rendered harmless upon discharge to the receiving water, compliance with the chronic toxicity limit may be determined after the test samples are adjusted to remove the influence of those substances. Written acknowledgement that the Executive Officer concurs with the Discharger’s demonstration and that the adjustment will not remove the influence of other substances must be obtained prior to any other such adjustment.
- e. Dilution Series.** The Discharger shall conduct tests at 40%, 20%, 10%, 5%, and 2.5%. The “%” represents percent effluent as discharged.

2. Chronic Toxicity Reporting Requirements

- a.** Toxicity test results for the current reporting period shall be provided in the self-monitoring report and shall include, at a minimum, for each test:
 - (1) Sample date
 - (2) Test initiation date
 - (3) Test species
 - (4) End point values for each dilution (e.g., number of young, growth rate, percent survival)
 - (5) No Observable Effect Level (NOEL) values in percent effluent. The NOEL shall equal to the IC₂₅ or EC₂₅ (see Appendix E-1). If the IC₂₅ or EC₂₅ cannot be statistically determined, the NOEL shall equal to the No Observable Effect Concentration (NOEC) derived using hypothesis testing. The NOEC is the

maximum percent effluent concentration that causes no observable effect on test organisms based on a critical life stage toxicity test.

- (6) IC₁₅, IC₂₅, IC₄₀, and IC₅₀ values (or EC₁₅, EC₂₅ ... etc.) as percent effluent
 - (7) TU_c values (100/NOEL, where NOEL = IC₂₅, EC₂₅, or NOEC as discussed in Appendix E-1
 - (8) Mean percent mortality (\pm s.d.) after 96 hours in 100% effluent (if applicable)
 - (9) IC₅₀ or EC₅₀ values for reference toxicant tests
 - (10) Available water quality measurements for each test (pH, dissolved oxygen, temperature, conductivity, hardness, salinity, ammonia)
- b.** The results of the most recent three chronic toxicity tests and the 3-sample median shall be provided in the self-monitoring report as TU_c's.

3. Chronic Toxicity Reduction Evaluation (TRE)

- a.** The Discharger shall prepare a generic TRE work plan within 90 days of the effective date of this Order to be ready to respond to toxicity events. The Discharger shall review and update the work plan as necessary so that it remains current and applicable to the discharge and discharge facilities.
- b.** Within 30 days of exceeding either chronic toxicity trigger, the Discharger shall submit to the Regional Water Board a TRE work plan, which shall be the generic work plan revised as appropriate for this toxicity event after consideration of available discharge data.
- c.** Within 30 days of the date of completion of the accelerated monitoring tests observed to exceed either trigger, the Discharger shall initiate a TRE in accordance with a TRE work plan that incorporates any and all comments from the Executive Officer.
- d.** The TRE shall be specific to the discharge and be in accordance with current technical guidance and reference materials, including USEPA guidance materials. The TRE shall be conducted as a tiered evaluation process, such as summarized below:
 - (1) Tier 1 consists of basic data collection (routine and accelerated monitoring).
 - (2) Tier 2 consists of evaluation of optimization of the treatment process, including operation practices and in-plant process chemicals.
 - (3) Tier 3 consists of a toxicity identification evaluation (TIE).
 - (4) Tier 4 consists of evaluation of options for additional effluent treatment processes.
 - (5) Tier 5 consists of evaluation of options for modifications of in-plant treatment processes.
 - (6) Tier 6 consists of implementation of selected toxicity control measures, and followup monitoring and confirmation of implementation success.

- e. The TRE may be ended at any stage if monitoring finds there is no longer consistent toxicity (i.e., compliance with Provision IV.C.2 of the Order).
- f. The objective of the TIE shall be to identify the substance or combination of substances causing the observed toxicity. All reasonable efforts using currently available TIE methodologies shall be employed.
- g. As toxic substances are identified or characterized, the Discharger shall continue the TRE by determining the sources and evaluating alternative strategies for reducing or eliminating the substances from the discharge. All reasonable steps shall be taken to reduce toxicity to levels consistent with chronic toxicity evaluation parameters.
- h. Many recommended TRE elements parallel required or recommended efforts of source control, pollution prevention, and stormwater control programs. TRE efforts should be coordinated with such efforts. To prevent duplication of efforts, evidence of complying with requirements or recommended efforts of such programs may be acceptable to comply with TRE requirements.
- i. The Regional Water Board recognizes that chronic toxicity may be episodic and identification of causes of and reduction of sources of chronic toxicity may not be successful in all cases. Consideration of enforcement action by the Regional Water Board will be based in part on the Discharger's actions and efforts to identify and control or reduce sources of consistent toxicity.

VI. RECEIVING WATER MONITORING REQUIREMENTS

The Discharger shall continue to participate in the San Francisco Estuary Institute's Regional Monitoring Program (RMP).

VII. OTHER MONITORING REQUIREMENTS

The Discharger shall continue to analyze biosolids at Monitoring Location BIO-001 as necessary to comply with the Regional Water Board Standard Provisions (Attachment G) and Provision VI.C.4.a of this Order.

VIII. REPORTING REQUIREMENTS

A. General Monitoring and Reporting Requirements

The Discharger shall comply with all Federal Standard Provisions (Attachment D) and Regional Standard Provisions (Attachment G) related to monitoring, reporting, and recordkeeping, with modifications shown in section VIII.D, below.

B. Self Monitoring Reports (SMRs)

1. **SMR Format.** The Discharger shall electronically submit SMRs using the State Water Board's California Integrated Water Quality System (CIWQS) Program Web site (<http://www.waterboards.ca.gov/ciwqs/index.html>). The CIWQS website will provide

additional directions for SMR submittals in the event of a service interruption for electronic submittal.

2. **SMR Due Dates and Contents.** The Discharger shall submit SMRs by the due dates, and with the contents, specified below:
 - a. **Monthly SMRs** — Monthly SMRs shall be due 30 days after the end of each calendar month, covering that calendar month. The monthly SMR shall contain the applicable items described in sections V.B and V.C of both Attachments D and G of this Order. See Provision VI.C.2.a (Effluent Characterization Study and Report) of this Order for information that must also be reported with the monthly SMR.
 - b. **Annual SMR** — Annual SMRs shall be due February 1 each year, covering the previous calendar year. The annual SMR shall contain the items described in Attachment G sections V.C.1.f. See also Provision VI.C.2.a of the Order (Effluent Characterization Study and Report) for requirements to submit reports with the annual SMR.
 - c. **Additional Specifications for Submitting SMRs to CIWQS** — The Discharger shall submit analytical results and other information using one of the following methods:

Table E-5. SMR Reporting for CIWQS

Parameter	Method of Reporting	
	EDF/CDF data upload or manual entry	Attached File
All parameters identified in influent, effluent, and receiving water monitoring tables (except Dissolved Oxygen and Temperature)	Required for All Results	
Dissolved Oxygen Temperature	Required for Monthly Maximum and Minimum Results Only ^[1]	Discharger may use this method for all results or keep records
Cyanide Arsenic Cadmium Chromium Copper Lead Mercury Nickel Selenium Silver Zinc Dioxins and Furans (by USEPA Method 1613)	Required for All Results ^[2]	
Antimony Beryllium Thallium Pollutants by USEPA Methods 601, 602, 608, 610, 614, 624, and 625	Not Required (unless identified in influent, effluent, or receiving water monitoring tables), But Encouraged ^[1]	Discharger may use this method and submit results with application for permit reissuance, unless data submitted by CDF/EDF upload

Volume and Duration of Blended Discharge	Required for All Blended Effluent Discharges	
Analytical Method	Not Required (Discharger may select “data unavailable”) ^[1]	
Collection Time Analysis Time	Not Required (Discharger may select “0:00”) ^[1]	

Footnotes:

- ^[1] The Discharger shall continue to monitor at the minimum frequency specified in the monitoring tables, keep records of the measurements, and make the records available upon request.
- ^[2] These parameters require EDF/CDF data upload or manual entry regardless of whether monitoring is required by this MRP or other provisions of this Order (except for biosolids, sludge, or ash provisions).

3. Monitoring Periods. Monitoring periods for all required monitoring shall be completed as set forth in the table below:

Table E-6. Monitoring Periods and Reporting Schedule

Sampling Frequency	Monitoring Period Begins On...	Monitoring Period
Continuous	Permit effective date	All
1/Day	Permit effective date	(Midnight through 11:59 PM) or any 24-hour period that reasonably represents a calendar day for purposes of sampling
1/Week	Permit effective date	Sunday through Saturday
1/Month	Permit effective date	First day of calendar month through last day of calendar month
5/Month	Permit effective date	First day of calendar month through last day of calendar month
1/Quarter	Permit effective date	Once during January 1 through March 31; once during April 1 through June 30; once during July 1 through September 30; and once through October 1 through December 31
1/Year	January 1, 2014	January 1 through December 31

- 4. RL and MDL Reporting.** The Discharger shall report with each sample result the Reporting Level (RL) and Method Detection Limit (MDL) as determined by the procedure in 40 CFR 136. The Discharger shall report the results of analytical determinations for the presence of chemical constituents in a sample using the following reporting protocols:
- a. Sample results greater than or equal to the RL shall be reported as measured by the laboratory (i.e., the measured chemical concentration in the sample).
 - b. Sample results less than the RL, but greater than or equal to the laboratory’s MDL, shall be reported as “Detected, but Not Quantified,” or DNQ. The estimated chemical concentration of the sample shall also be reported. For purposes of data collection, the laboratory shall write the estimated chemical concentration next to DNQ. The laboratory may, if such information is available, include numerical estimates of the data quality for the reported result. Numerical estimates of data quality may be percent accuracy (+/- a percentage of the reported value), numerical ranges (low to high), or any other means the laboratory considers appropriate.

- c. Sample results less than the laboratory’s MDL shall be reported as “Not Detected” or ND.
- d. The Discharger shall instruct laboratories to establish calibration standards so that the minimum level (ML) value (or its equivalent if there is differential treatment of samples relative to calibration standards) is the lowest calibration standard. At no time is the Discharger to use analytical data derived from extrapolation beyond the lowest point of the calibration curve.

C. Discharge Monitoring Reports

- 1. As described in section VIII.B.1 above, at any time during the term of this permit, the State or Regional Water Board may notify the Discharger to electronically submit SMRs that will satisfy federal requirements for submittal of Discharge Monitoring Reports (DMRs). Until such notification is given, the Discharger shall submit DMRs in accordance with the requirements described below.
- 2. DMRs must be signed and certified as required by the Standard Provisions (Attachment D). The Discharger shall submit the original DMR and one copy of the DMR to one of the addresses listed below:

Standard Mail	FedEx/UPS/Other Private Carriers
State Water Resources Control Board Division of Water Quality c/o DMR Processing Center PO Box 100 Sacramento, CA 95812-1000	State Water Resources Control Board Division of Water Quality c/o DMR Processing Center 1001 I Street, 15 th Floor Sacramento, CA 95814

- 3. All discharge monitoring results must be reported on the official USEPA pre-printed DMR forms (EPA Form 3320-1). Forms that are self-generated will not be accepted unless they follow the exact same format of EPA Form 3320-1.

D. Modifications to Attachment G

- 1. **Attachment G sections V.C.1.f and V.C.1.g are revised as follows, and section V.C.1.h (Reporting data in electronic format) is deleted.**

- f. Annual self-monitoring report requirements

By the date specified in the MRP, the Discharger shall submit an annual report to the Regional Water Board covering the previous calendar year. The report shall contain the following:

- 1) Annual compliance summary table of treatment plant performance, including documentation of any blending events (this summary table is not required if the Discharger has submitted the year’s monitoring results to CIWQS in electronic reporting format by EDF/CDF upload or manual entry);

- 2) Comprehensive discussion of treatment plant performance and compliance with the permit (This discussion shall include any corrective actions taken or planned, such as changes to facility equipment or operation practices that may be needed to achieve compliance, and any other actions taken or planned that are intended to improve performance and reliability of the Discharger’s wastewater collection, treatment, or disposal practices.);
 - 3) Both tabular and graphical summaries of the monitoring data for the previous year if parameters are monitored at a frequency of monthly or greater (this item is not required if the Discharger has submitted the year’s monitoring results to CIWQS in electronic reporting format by EDF/CDF upload or manual entry);
 - 4) List of approved analyses, including the following:
 - (i) List of analyses for which the Discharger is certified;
 - (ii) List of analyses performed for the Discharger by a separate certified laboratory (copies of reports signed by the laboratory director of that laboratory shall not be submitted but be retained onsite); and
 - (iii) List of “waived” analyses, as approved;
 - 5) Plan view drawing or map showing the Discharger’s facility, flow routing, and sampling and observation station locations;
 - 6) Results of annual facility inspection to verify that all elements of the SWPP Plan are accurate and up to date (only required if the Discharger does not route all stormwater to the headworks of its wastewater treatment plant); and
 - 7) Results of facility report reviews (The Discharger shall regularly review, revise, and update, as necessary, the O&M Manual, the Contingency Plan, the Spill Prevention Plan, and Wastewater Facilities Status Report so that these documents remain useful and relevant to current practices. At a minimum, reviews shall be conducted annually. The Discharger shall include, in each Annual Report, a description or summary of review and evaluation procedures, recommended or planned actions, and an estimated time schedule for implementing these actions. The Discharger shall complete changes to these documents to ensure they are up-to-date.).
- g. Report submittal

The Discharger shall submit SMRs addressed as follows, unless the Discharger submits SMRs electronically to CIWQS:

California Regional Water Quality Control Board
San Francisco Bay Region
1515 Clay Street, Suite 1400
Oakland, CA 94612
Attn: NPDES Wastewater Division

h. Reporting data in electronic format – *Deleted*

2. Attachment G sections V.E.2, V.E.2.a, and V.E.2.c are revised as follows, and sections V.E.2.b (24-hour Certification) and V.E.2.d (Communication Protocol) are deleted.

2. Unauthorized Discharges from Municipal Wastewater Treatment Plants²

The following requirements apply to municipal wastewater treatment plants that experience an unauthorized discharge at their treatment facilities and supersede requirements imposed on the Discharger by the Executive Officer by letter of May 1, 2008.

a. Two (2)-Hour Notification

For any unauthorized discharges that enter a drainage channel or a surface water, the Discharger shall, as soon as possible, but not later than two (2) hours after becoming aware of the discharge, notify the California Emergency Management Agency (CalEMA, currently 800-852-7550), the local health officers or directors of environmental health with jurisdiction over the affected water bodies, and the Regional Water Board. Timely notification by the Discharger to CalEMA also satisfies notification to the Regional Water Board. Notification shall include the following:

- 1) Incident description and cause;
- 2) Location of threatened or involved waterway(s) or storm drains;
- 3) Date and time the unauthorized discharge started;
- 4) Estimated quantity and duration of the unauthorized discharge (to the extent known), and the estimated amount recovered;
- 5) Level of treatment prior to discharge (e.g., raw wastewater, primary treated, undisinfected secondary treated, and so on); and
- 6) Identity of the person reporting the unauthorized discharge.

b. 24-hour Certification – *Deleted*

c. 5-day Written Report

Within five business days, the Discharger shall submit a written report that includes, in addition to the information required above, the following:

- 1) Methods used to delineate the geographical extent of the unauthorized discharge within receiving waters;

² California Code of Regulations, Title 23, Section 2250(b), defines an unauthorized discharge to be a discharge, not regulated by waste discharge requirements, of treated, partially treated, or untreated wastewater resulting from the intentional or unintentional diversion of wastewater from a collection, treatment or disposal system.

- 2) Efforts implemented to minimize public exposure to the unauthorized discharge;
 - 3) Visual observations of the impacts (if any) noted in the receiving waters (e.g., fish kill, discoloration of water) and the extent of sampling if conducted;
 - 4) Corrective measures taken to minimize the impact of the unauthorized discharge;
 - 5) Measures to be taken to minimize the chances of a similar unauthorized discharge occurring in the future;
 - 6) Summary of Spill Prevention Plan or O&M Manual modifications to be made, if necessary, to minimize the chances of future unauthorized discharges; and
 - 7) Quantity and duration of the unauthorized discharge, and the amount recovered.
- d. Communication Protocol – *Deleted*

**APPENDIX E-1
CHRONIC TOXICITY
DEFINITION OF TERMS AND SCREENING PHASE REQUIREMENTS**

I. Definition of Terms

- A. No observed effect level (NOEL) for compliance determination is equal to IC₂₅ or EC₂₅. If the IC₂₅ or EC₂₅ cannot be statistically determined, the NOEL shall be equal to the NOEC derived using hypothesis testing.
- B. Effective concentration (EC) is a point estimate of the toxicant concentration that would cause an adverse effect on a quantal, “all or nothing,” response (such as death, immobilization, or serious incapacitation) in a given percent of the test organisms. If the effect is death or immobility, the term lethal concentration (LC) may be used. EC values may be calculated using point estimation techniques such as probit, logit, and Spearman-Kärber. EC₂₅ is the concentration of toxicant (in percent effluent) that causes a response in 25 percent of the test organisms.
- C. Inhibition concentration (IC) is a point estimate of the toxicant concentration that would cause a given percent reduction in a nonlethal, nonquantal biological measurement, such as growth. For example, an IC₂₅ is the estimated concentration of toxicant that would cause a 25 percent reduction in average young per female or growth. IC values may be calculated using a linear interpolation method such as USEPA's Bootstrap Procedure.
- D. No observed effect concentration (NOEC) is the highest tested concentration of an effluent or a toxicant at which no adverse effects are observed on the aquatic test organisms at a specific time of observation. It is determined using hypothesis testing.

II. Chronic Toxicity Screening Phase Requirements

- A. The Discharger shall perform screening phase monitoring:
 - 1. Subsequent to any significant change in the nature of the effluent discharged through changes in sources or treatment, except those changes resulting from reductions in pollutant concentrations attributable to source control efforts, or
 - 2. Prior to permit reissuance. Screening phase monitoring data shall be included in the NPDES permit application for reissuance. The information shall be as recent as possible, but may be based on screening phase monitoring conducted within 5 years before the permit expiration date. The Discharger has the option of completing the screening phase monitoring on its own or in conjunction with other local dischargers.
- B. Design of the screening phase shall, at a minimum, consist of the following elements:
 - 1. Use of test species specified in Appendix E-2, attached, and use of the protocols referenced in those tables.
 - 2. Two stages:

- a. Stage 1 shall consist of a minimum of one battery of tests conducted concurrently. Selection of the type of test species and minimum number of tests shall be based on Appendix E-2.
 - b. Stage 2 shall consist of a minimum of two test batteries conducted at a monthly frequency using the three most sensitive species based on the Stage 1 test results.
3. Appropriate controls.
 4. Concurrent reference toxicant tests.
 5. Dilution series of 100%, 50%, 25%, 12.5%, 6.25%, and 0 %, where “%” is percent effluent as discharged, or as otherwise approved the Executive Officer if different dilution ratios are needed to reflect discharge conditions.
- C. The Discharger shall submit a screening phase proposal. The proposal shall address each of the elements listed above. If within 30 days, the Executive Officer does not comment, the Discharger shall commence with screening phase monitoring.

**APPENDIX E-2
 SUMMARY OF TOXICITY TEST SPECIES REQUIREMENTS**

Table AE-1. Critical Life Stage Toxicity Tests for Estuarine Waters

Species	(Scientific Name)	Effect	Test Duration	Reference
Alga	<i>(Skeletonema costatum)</i> <i>(Thalassiosira pseudonana)</i>	Growth rate	4 days	1
Red alga	<i>(Champia parvula)</i>	Number of cystocarps	7–9 days	3
Giant kelp	<i>(Macrocystis pyrifera)</i>	Percent germination; germ tube length	48 hours	2
Abalone	<i>(Haliotis rufescens)</i>	Abnormal shell development	48 hours	2
Oyster Mussel	<i>(Crassostrea gigas)</i> <i>(Mytilus edulis)</i>	Abnormal shell development; percent survival	48 hours	2
Echinoderms - Urchins Sand dollar	<i>(Strongylocentrotus purpuratus, S. franciscanus)</i> <i>(Dendraster excentricus)</i>	Percent fertilization	1 hour	2
Shrimp	<i>(Americamysis bahia)</i>	Percent survival; growth	7 days	3
Shrimp	<i>(Holmesimysis costata)</i>	Percent survival; growth	7 days	2
Topsmelt	<i>(Atherinops affinis)</i>	Percent survival; growth	7 days	2
Silversides	<i>(Menidia beryllina)</i>	Larval growth rate; percent survival	7 days	3

Toxicity Test References:

1. American Society for Testing Materials (ASTM). 1990. Standard Guide for Conducting Static 96-Hour Toxicity Tests with Microalgae. Procedure E 1218-90. ASTM, Philadelphia, PA.
2. Short-term Methods for Estimating the Chronic Toxicity of Effluent and Receiving Waters to West Coast Marine and Estuarine Organisms. EPA/600/R-95/136. August 1995.
3. Short-term Methods for Estimating the Chronic Toxicity of Effluents and Receiving Waters to Marine and Estuarine Organisms. EPA/821/R-02/014. October 2002.

Table AE-2. Critical Life Stage Toxicity Tests for Fresh Waters

Species	(Scientific Name)	Effect	Test Duration	Reference
Fathead minnow	<i>Pimephales promelas</i>	Survival; growth rate	7 days	4
Water flea	<i>Ceriodaphnia dubia</i>	Survival; number of young	7 days	4
Alga	<i>Selenastrum capricornutum</i>	Final cell density	4 days	4

Toxicity Test Reference:

4. Short-term Methods for Estimating the Chronic Toxicity of Effluents and Receiving Waters to Freshwater Organisms, fourth Edition Chronic manual (EPA-821-R-02-013, October 2002).

Table AE-3. Toxicity Test Requirements for Stage One Screening Phase

Requirements	Receiving Water Characteristics		
	Discharges to Coast	Discharges to San Francisco Bay ^[1]	
	Ocean	Marine/Estuarine	Freshwater
Taxonomic diversity	1 plant 1 invertebrate 1 fish	1 plant 1 invertebrate 1 fish	1 plant 1 invertebrate 1 fish
Number of tests of each salinity type: Freshwater ^[2] Marine/Estuarine	0 4	1 or 2 3 or 4	3 0
Total number of tests	4	5	3

- ^[1] (a) Marine refers to receiving water salinities greater than 1 part per thousand (ppt) at least 95 percent of the time during a normal water year.
 (b) Freshwater refers to receiving water with salinities less than 1 ppt at least 95 percent of the time during a normal water year.
 (c) Estuarine refers to receiving water salinities that fall between those of marine and freshwater, as described above.
- ^[2] The freshwater species may be substituted with marine species if:
 (a) The salinity of the effluent is above 1 ppt greater than 95 percent of the time, or
 (b) The ionic strength (TDS or conductivity) of the effluent at the test concentration used to determine compliance is documented to be toxic to the test species.

ATTACHMENT F - FACT SHEET

Contents

I. Permit Information.....	F-3
II. Facility Description.....	F-4
A. Description of Wastewater and Biosolids Treatment	F-4
B. Discharge Point and Receiving Waters.....	F-5
C. Summary of Existing Requirements and Self-Monitoring Report Data.....	F-5
D. Compliance Summary.....	F-6
E. Planned Changes	F-7
F. Blending Summary	F-7
III. Applicable Plans, Policies, and Regulations.....	F-9
A. Legal Authorities	F-9
B. California Environmental Quality Act (CEQA)	F-9
C. State and Federal Regulations, Policies, and Plans.....	F-9
D. Impaired Water Bodies on CWA 303(d) List.....	F-10
IV. Rationale For Effluent Limitations and Discharge Specifications	F-11
A. Discharge Prohibitions.....	F-11
B. Conventional and Non-Conventional Pollutant Limitations.....	F-13
1. Scope and Authority	F-13
2. Effluent Limitations for Conventional and Non-conventional Pollutants	F-13
C. Water Quality-Based Effluent Limitations (WQBELs) for Toxic Substances.....	F-14
1. Scope and Authority	F-14
2. Applicable Beneficial Uses and Water Quality Objectives	F-14
3. Determining the Need for WQBELs.....	F-16
4. WQBEL Calculations	F-20
5. Whole Effluent Acute Toxicity.....	F-28
6. Whole Effluent Chronic Toxicity	F-28
7. Antidegradation.....	F-29
V. Rationale for Receiving Water Limitations	F-29
VI. Rationale for Monitoring and Reporting Requirements	F-30
A. Influent Monitoring.....	F-30
B. Effluent Monitoring	F-30
C. Whole Effluent Toxicity Testing Requirements.....	F-30
D. Receiving Water Monitoring	F-31
VII. Rationale for Provisions.....	F-31
A. Standard Provisions (Provision VI.A)	F-31
B. Monitoring and Reporting Requirements (Provision VI.B)	F-31
C. Special Provisions (Provision VI.C).....	F-32
1. Reopener Provisions	F-32
2. Effluent Characterization Study and Report	F-32
3. Best Management Practices and Pollutant Minimization Program	F-33
VIII. Public Participation	F-34
A. Notification of Interested Parties	F-34
B. Written Comments	F-34
C. Public Hearing	F-35
D. Waste Discharge Requirements Petitions.....	F-35

E. Information and Copying F-35
 F. Register of Interested Persons F-35
 G. Additional Information F-36

Tables

Table F-1. Facility Information F-3
 Table F-2. Outfall Location F-5
 Table F-3. Historic Effluent Limitations and Monitoring Data F-5
 Table F-4. Compliance with Previous Order Provisions F-6
 Table F-5. Historical Blending Summary F-7
 Table F-6. Basin Plan Beneficial Uses F-9
 Table F-7. Secondary Treatment Requirements F-13
 Table F-8. Reasonable Potential Analysis Summary F-17
 Table F-9. WQBEL Calculations F-27
 Table F-10. Monitoring Requirements Summary F-31

ATTACHMENT F – FACT SHEET

As described in section II of this Order, this Fact Sheet includes the legal requirements and technical rationale that serve as the basis for the requirements of this Order.

This Order has been prepared under a standardized format to accommodate a broad range of discharge requirements for dischargers in California. Only those sections or subsections of this Order that are specifically identified as “not applicable” have been determined not to apply to this Discharger. Sections or subsections of this Order not specifically identified as “not applicable” fully apply to this Discharger.

I. PERMIT INFORMATION

The following table summarizes administrative information related to the Sanitary District No. 5 Wastewater Treatment Plant and its service area:

Table F-1. Facility Information

WDID	2 215021001
CIWQS Place ID	239497
Discharger	Sanitary District No. 5 of Marin County
Name of Facility	Sanitary District No. 5 Wastewater Treatment Plant and wastewater collection system
Facility Address	2001 Paradise Drive, Tiburon, CA 94920 Marin County
Facility Contact, Title, Phone	Tony Rubio Wastewater Facilities Manager (415) 435-1501 ext.106 trubio@sani5.org
Authorized Person to Sign and Submit Reports	Same as above
Mailing Address	P.O. Box 227, Tiburon, CA 94920
Billing Address	Same as Mailing Address
Type of Facility	Publicly Owned Treatment Works (POTW)
Major or Minor Facility	Major
Threat to Water Quality	2
Complexity	A
Pretreatment Program	None
Reclamation Requirements	None
Facility Permitted Flow	0.98 million gallons per day (MGD)
Facility Design Flow	0.98 MGD (average dry weather flow) 2.3 MGD (peak wet weather flow)
Watershed	San Francisco Bay Basin
Receiving Water	Raccoon Strait in Central San Francisco Bay
Receiving Water Type	Marine
Service Area	Town of Tiburon, City of Belvedere, and surrounding unincorporated area
Service Area Population	Approximately 8,400

- A. The Sanitary District No. 5 of Marin County (hereinafter Discharger) owns and operates a publicly owned treatment works (hereinafter the Plant) and wastewater collection system (hereinafter,

collectively, the Facility). The Plant provides secondary treatment of wastewater collected from the service area and discharges it to Central San Francisco Bay.

For the purposes of this Order, references to the “discharger” or “permittee” in applicable federal and state laws, regulations, plans, or policy are held to be equivalent to references to the Discharger herein.

- B.** Discharge of treated wastewater from the Plant to Central San Francisco Bay, a water of the State and the United States, is currently regulated by Order No. R2-2008-0057 (NPDES Permit No. CA0037753), which was adopted on July 9, 2008, became effective on September 1, 2008, and expires on August 31, 2013. The discharge is also currently regulated under Order No. R2-2012-0096 (NPDES Permit No. CA0038849), which establishes requirements on mercury and polychlorinated biphenyls (PCBs) from wastewater discharges in the region. This Order does not affect the mercury and PCBs permit.
- C.** On March 1, 2013, the Discharger filed a Report of Waste Discharge and application for reissuance of its waste discharge requirements and NPDES permit.

II. FACILITY DESCRIPTION

A. Description of Wastewater and Biosolids Treatment

- 1. Facility Background.** The Discharger owns and operates the Plant and its associated wastewater collection system, consisting of 33 miles of gravity sewer lines, 5 miles of forcemain, and 22 pump stations. There are no satellite collection systems. The Plant, located in Tiburon, provides secondary treatment of domestic and commercial wastewater for the Town of Tiburon, City of Belvedere, and a small unincorporated area of the Tiburon Peninsula around the treatment plant. The service area population is approximately 8,400. The Plant has a dry weather design capacity of 0.98 MGD and can treat up to 2.3 MGD during wet weather (based on the design capacity of the secondary treatment system). From January 2010 through December 2012, the average annual flow was 0.63 MGD, with a maximum daily flow rate of 2.56 MGD. Attachment B provides a map of the area around the Facility.
- 2. Treatment Description.** Wastewater treatment at the Plant includes raw influent grinding (three grinders), primary sedimentation (two dry weather primary clarifiers and one extra clarifier used during wet weather), activated sludge biological treatment (two aeration basins), secondary clarification (two secondary clarifiers), sodium hypochlorite disinfection, and sodium bisulfite dechlorination. Treated effluent is combined with Sewerage Agency of Southern Marin effluent before discharge. Attachment C provides a treatment process schematic diagram.

The Plant has a wet weather treatment capacity of 2.3 MGD. During periods of heavy rain (generally greater than one inch) when the influent flow exceeds 2.3 MGD, the extra 110,000-gallon primary clarifier (capable of sustaining flows of up to 4.4 MGD for three hours of peak flow) is used as a temporary holding tank to retain excess influent flows before they are routed to the headworks for treatment. During sustained significant rain, when onsite storage is maximized and influent flows are above 2.3 MGD, the Discharger diverts and blends any portion of the primary-treated flow above 2.3 MGD with secondary-treated effluent to prevent washout of the microbial populations in the secondary treatment system. This blended effluent is then chlorinated and dechlorinated prior to discharge.

3. **Biosolids Management.** Solids collected from the Plant are thickened, anaerobically-digested, and dewatered by a screw press. The Plant generates an average of 86.2 dry metric tons of biosolids per year, which are disposed of at the Redwood Sanitary Landfill in Novato.
4. **Stormwater.** All stormwater originating within the Plant area is directed to the Plant’s headworks and treated with the wastewater.

B. Discharge Point and Receiving Waters

The Facility discharges treated effluent to Raccoon Strait in Central San Francisco Bay through a 36-inch outfall with a 195-foot, 60-port diffuser, 850 feet (including the diffuser) offshore at a depth of 84 feet below mean sea level. The Discharger shares the outfall with the Sewerage Agency of Southern Marin Wastewater Treatment Plant at Mill Valley. (The Sewerage Agency of Southern Marin’s discharge is regulated separately by Order No. R2-2012-0094 [NPDES Permit No. CA0037711].) The locations of the discharge point and receiving waters are indicated in the table below:

Table F-2. Outfall Location

Discharge Point	Effluent Description	Discharge Point Latitude	Discharge Point Longitude	Receiving Water
001	Secondary-Treated Wastewater	37° 52' 12" N	122° 27' 05" W	Raccoon Strait in Central San Francisco Bay

C. Summary of Existing Requirements and Self-Monitoring Report Data

Effluent limitations applicable to Discharge Point No. 001 contained in the previous order (Order No. R2-2008-0057) and representative monitoring data from the term of the previous order are presented below:

Table F-3. Historic Effluent Limitations and Monitoring Data

Parameter	Units	Historic Effluent Limitations			Monitoring Data (From 9/2008- 12/2012)			
		Monthly Average	Weekly Average	Daily Maximum	Highest Monthly Average	Highest Weekly Average	Maximum Daily Discharge	Daily Max Discharge Range
Biochemical Oxygen Demand (BOD ₅)	mg/L	30	45	--	28	37	37	5 – 37
BOD ₅ Monthly Removal	%	85	--	--	91 (min)	--	--	91 – 98
Total Suspended Solids (TSS)	mg/L	30	45	---	12	26	41	1 – 41
TSS Monthly removal	%	85	--	--	91 (min)	--	--	91 – 98
Oil and Grease	mg/L	10	---	20	--	--	5	<5 – 5
pH	s.u.	6.0 – 9.0 at all times			6.45 – 7.54			
Total Chlorine Residual	mg/L	---	---	0.0	--	--	0	0
Total Coliform Bacteria	MPN/100 mL	240 (5-Sample Moving Median)			--	--	170	2 – 170
		10,000 (Single-Sample Maximum)			--	--	1,600	2 – 1,600
Copper	µg/L	72/54 ^[1]	--	98/73 ^[1]	--	--	12	3 – 12
Selenium	µg/L	3.7	--	9.0	--	--	1.4	0.2 – 1.4

Parameter	Units	Historic Effluent Limitations			Monitoring Data (From 9/2008- 12/2012)			
		Monthly Average	Weekly Average	Daily Maximum	Highest Monthly Average	Highest Weekly Average	Maximum Daily Discharge	Daily Max Discharge Range
Cyanide	µg/L	20	--	45	--	--	11	0.6 – 11
Dioxin TEQ ^[2]	µg/L	1.4x10 ⁻⁸	--	2.8x10 ⁻⁸	--	--	5.3 x 10 ⁻⁸	ND – 5.3 x 10 ⁻⁸
Bis(2-ethylhexyl) phthalate	µg/L	58	--	120	--	--	1.9	ND – 1.9
Total Ammonia	mg/L	100	--	210	28	--	30	2.9 – 30
Acute Toxicity	% Survival	Not less than 90% (11-Sample Median)			95 ^[3]			
		Not less than 70% (11-Sample 90 th Percentile)			95 ^[3]			

Footnotes:

- mg/L = milligrams per liter
- s.u. = standard units
- MPN/100 mL = Most Probable Number/100 milliliters
- ND = Not Detected

^[1] The previous order originally established a copper AMEL of 72 µg/L and an MDEL of 98 µg/L. Later, in 2008, an AMEL of 54 µg/L and MDEL of 73 µg/L became effective based on new copper site-specific objectives.
^[2] Dioxin-TEQ limitations are not effective until June 1, 2018.
^[3] This represents the lowest 11-sample median over the previous order term.

D. Compliance Summary

- 1. Compliance with Effluent Limitations.** During the term of the previous order, the Discharger did not violate any effluent limitations.
- 2. Compliance with Previous Order Provisions.** The table below presents a list of special activities required by the previous order and the status of those requirements:

Table F-4. Compliance with Previous Order Provisions

Provision Number	Requirement	Status of Completion
VI.C.6 – Corrective Measures to Minimize Blending	Task 1. Submit technical report describing studies completed from 2004-2005 that evaluated collection systems.	Completed, submitted September 10, 2008
	Task 2. Submit a copy of 10-year, \$3.5 million Sewer Rehabilitation Plan to implement Task 1.	Completed, submitted September 10, 2008
	Task 3. Implement measures identified in Sewer Rehabilitation Plan.	Ongoing, implementing work plan schedule
	Task 4. Report on progress of Sewer Rehabilitation Plan together with impact on reduction blending.	Completed, included in annual self-monitoring reports
	Task 5. No Feasible Alternatives Analysis.	Completed, submitted March 1, 2013, with Report of Waste Discharge
VI.C.7 – Dioxin-TEQ Compliance Schedule	Task 1. Continue semi-annual monitoring for dioxin-TEQ.	Completed, monitoring conducted from 2008-2012
	Task 2. Report status of monitoring efforts.	Completed, included in March and September self-monitoring reports.
	Task 3-7. If dioxin-TEQ concentrations exceed final effluent limits, implement source control activities or other actions as appropriate.	Requirement not triggered

VI.C.8 – Cyanide Action Plan	Task 1. Review Potential Cyanide Sources	Completed, submitted with November 2008 self-monitoring report
	Task 2. Develop and implement Cyanide Control Program	Completed, provided in the 2008 Annual Pollution Prevention Report
	Task 3. Report on Status of Cyanide Control program	Completed, provided in Annual Pollution Prevention Reports
VI.C.8 – Copper Action Plan	Task 1. Review Potential Copper Sources	Completed, submitted with November 2008 self-monitoring report.
	Task 2. Implement Copper Control Program	Completed, provided in 2008 Annual Pollution Prevention Report
	Task 3. Implement Additional Measures	Requirement not triggered
	Task 4. Report on Status of Copper Control program	Completed, provided in Annual Pollution Prevention Reports

3. Unauthorized Discharge. The Discharger reported one unauthorized discharge during the term of the previous order. On May 15, 2013, a Sprint Nextel contractor working on the Plant grounds broke a 1.5-inch pipe, causing the release of 3,300 gallons of undisinfectated secondary-treated effluent to a storm drain leading to San Francisco Bay.

E. Planned Changes

The Discharger anticipates no changes in treatment processes or capacity. Planned and recent upgrades and maintenance activities to the Plant and the collection system are discussed in sections II.F and IV.A.3.B of this Fact Sheet.

F. Blending Summary

Blending, as defined in the previous order, occurred 23 times over the previous order term, totaling 5.9 million gallons. At an average daily influent flow rate of 0.63 MGD, this constitutes approximately 0.5% of the total influent flows the Plant received during the last five years. The largest of these blending events, occurring on February 15, 2009, discharged approximately 1.1 million gallons of blended wastewater into the receiving water. Based on available water quality data, the total suspended solids (TSS) concentrations in the effluent during these blending events ranged from 3 mg/L to 18 mg/L, with a median of 9.5 mg/L, which is within the permitted limits and not substantially different from when the Discharger was not blending. (The daily maximum TSS concentration over the previous order term, excluding the days of blending, ranged from 1 mg/L to 41 mg/L, and the median was 6.5 mg/L.) The Discharger monitored other pollutants with effluent limits in the previous order and reported no effluent limit violations.

Table F-5. Historical Blending Summary

Calendar Year	Date	Blended Volume (million gallons)	Total Rainfall (inches)	Effluent Limit Violations
2009	2/15/2009	1.051	2.22	None
2009	2/16/2009	0.495	0.65	None
2009	3/5/2009	0.22	1.05	None
2009	10/13/2009	0.147	3.83	None

2010	1/18/2010	0.187	0.96	None
2010	1/19/2010	0.449	2.03	None
2010	1/20/2010	0.302	1.52	None
2010	1/26/2010	0.013	0.32	None
2010	10/24/2010	0.020	0.35	None
2010	12/19/2010	0.266	1.09	None
2010	12/28/2010	0.611	1.37	None
2011	2/17/2011	0.006	1.00	None
2011	2/25/2011	0.018	1.75	None
2011	3/18/2011	0.028	1.75	None
2011	3/19/2011	0.181	1.35	None
2011	3/24/2011	0.366	1.15	None
2011	3/26/2011	0.317	2.65	None
2012	1/20/2012	0.125	4.00	None
2012	3/14/2012	0.233	2.85	None
2012	3/16/2012	0.260	1.65	None
2012	11/30/2012	0.028	1.75	None
2012	12/1/2012	0.111	2.50	None
2012	12/2/2012	0.475	2.60	None

During the previous order term, the Discharger implemented various measures to reduce blending, including the following:

- Initiating an 18-month (June 2012 – November 2013), \$12-million Treatment Plant Rehabilitation Project. The Discharger included \$1 million for the addition and retooling of an offline aeration basin and a surge tank to attenuate wet weather peak flows. This expansion, when completed, will more than double the onsite storage capacity from 117,249 gallons to 315,249 gallons (sufficient to eliminate five of the six most recent blending events had it been in place earlier).
- Continuing implementation of a 10-year (2005-2015), \$2-million Sewer Rehabilitation Plan to address structures and pipes found to be in unsatisfactory condition based on a closed circuit video evaluation of the collection system. The Discharger performed collection system spot repairs and rehabilitation projects, and conducted on-going cleaning and maintenance work in both Tiburon and Belvedere.
- Conducted flow monitoring between December 2010 and March 2011 in the collection system to identify the baseflow and the influence of infiltration and inflow from sources outside the sewer lines (e.g., private laterals, faulty manholes, and other degraded infrastructure). The study identified four sub-drainage areas as having the highest inflow volume. Followup smoke testing identified 23 sites for corrective action. The Discharger plans to address these 23 sites as part of a 10-year Capital Improvement Plan (2013-2023).
- Coordinated the passage of Ordinance 2010-01, which requires property owners to install backflow check valve devices and complete sewer lateral inspections and repairs as part of any Connection Permit application for residential and commercial structures.

As discussed in section IV.A.3.B of this Fact Sheet, the Discharger proposes to continue reducing inflow and infiltration in the collection system, while increasing storage capacity at the Plant, to reduce blending.

III. APPLICABLE PLANS, POLICIES, AND REGULATIONS

This Order’s requirements are based on the requirements and authorities described in this section.

A. Legal Authorities

This Order is issued pursuant to federal Clean Water Act (CWA) section 402 and implementing regulations adopted by the USEPA and California Water Code (CWC) chapter 5.5, division 7, commencing with section 13370. It serves as an NPDES permit for point source discharges from the Facility to surface waters. This Order also serves as Waste Discharge Requirements (WDRs) pursuant to CWC article 4, chapter 4, division 7, commencing with section 13260.

B. California Environmental Quality Act (CEQA)

Under CWC section 13389, this action to issue an NPDES permit is exempt from Chapter 3 of CEQA.

C. State and Federal Regulations, Policies, and Plans

- 1. Water Quality Control Plan.** *The Water Quality Control Plan for the San Francisco Bay Basin* (hereinafter Basin Plan) is the Regional Water Board’s master water quality control planning document. It designates beneficial uses and water quality objectives for waters of the State, including surface and groundwater. It also includes implementation programs to achieve Water quality objectives. The Basin Plan was duly adopted by the Regional Water Board and approved by the State Water Board, the Office of Administrative Law, and USEPA. Requirements of this Order implement the Basin Plan.

The Basin Plan beneficial uses of Central San Francisco Bay are listed below. The Basin Plan implements State Water Board Resolution No. 88-63, which establishes State policy that all waters, with certain exceptions, should be considered suitable or potentially suitable for municipal or domestic supply. Because of the marine influence on Central San Francisco Bay, total dissolved solids levels exceed 3,000 mg/L and thereby meet an exception to State Water Board Resolution No. 88-63. The MUN designation therefore does not apply to the receiving water.

Table F-6. Basin Plan Beneficial Uses

Receiving Water Name	Beneficial Uses
Central San Francisco Bay	Industrial Service Supply (IND) Industrial Process Supply (PROC) Commercial, and Sport Fishing (COMM) Shellfish Harvesting (SHELL) Estuarine Habitat (EST) Fish Migration (MIGR) Preservation of Rare and Endangered Species (RARE) Fish Spawning (SPWN) Wildlife Habitat (WILD) Water Contact Recreation (REC1) Non-Contact Water Recreation (REC2) Navigation (NAV)

The State Water Board's Water Quality Control Plan for Enclosed Bays and Estuaries—Part 1, Sediment Quality became effective on August 25, 2009. This plan supersedes other narrative sediment quality objectives and establishes new sediment quality objectives and related implementation provisions for specifically defined sediments in most bays and estuaries.

2. **National Toxics Rule (NTR) and California Toxics Rule (CTR).** USEPA adopted the NTR on December 22, 1992, and amended it on May 4, 1995, and November 9, 1999. About 40 criteria in the NTR and apply in California. On May 18, 2000, USEPA adopted the CTR which promulgated new toxics criteria for California and, in addition, incorporated the previously adopted NTR criteria that applied in the State. The CTR was amended on February 13, 2001. These rules contain water quality criteria (WQC) for priority toxic pollutants.
3. **State Implementation Policy.** On March 2, 2000, the State Water Board adopted the *Policy for Implementation of Toxics Standards for Inland Surface Waters, Enclosed Bays, and Estuaries of California* (hereinafter State Implementation Policy [SIP]). The SIP became effective on April 28, 2000, with respect to the priority pollutant criteria promulgated through the NTR and to the water quality objectives established in the Basin Plan. The SIP became effective on May 18, 2000, with respect to the priority pollutant criteria promulgated through the CTR. The State Water Board adopted amendments to the SIP on February 24, 2005, that became effective on July 13, 2005. The SIP establishes implementation provisions for priority pollutant criteria and objectives and provisions for chronic toxicity control. Requirements of this Order implement the SIP.
4. **Alaska Rule.** On March 30, 2000, USEPA revised its regulation that specifies when new and revised state and tribal water quality standards (WQS) become effective for CWA purposes (65 Fed. Reg. 24641 [April 27, 2000], codified at 40 CFR 131.21). Under the revised regulation (also known as the Alaska Rule), new and revised standards submitted to USEPA after May 30, 2000, must be approved by USEPA before being used for CWA purposes. The final rule also provides that standards already in effect and submitted to USEPA by May 30, 2000, may be used for CWA purposes, whether or not approved by USEPA.
5. **Antidegradation Policy.** NPDES regulations at 40 CFR 131.12 require that state WQS include an antidegradation policy consistent with the federal policy. The State Water Board established California's antidegradation policy in State Water Board Resolution No. 68-16, which incorporates the federal antidegradation policy where the federal policy applies under federal law and requires that existing quality of waters be maintained unless degradation is justified based on specific findings. The Basin Plan implements, and incorporates by reference, both the State and federal antidegradation policies.
6. **Anti-Backsliding Requirements.** CWA sections 402(o)(2) and 303(d)(4) and 40 CFR 122.44(l) prohibit backsliding in NPDES permits. These anti-backsliding provisions require that effluent limitations in a reissued permit must be as stringent as those in the previous order, with some exceptions in which limitations may be relaxed.

D. Impaired Water Bodies on CWA 303(d) List

In October 2011, USEPA approved a revised list of impaired water bodies prepared pursuant to CWA section 303(d), which requires identification of specific water bodies where it is expected that water quality standards will not be met after implementation of technology-based effluent

limitations on point sources. Where it has not done so already, the Regional Water Board plans to adopt Total Maximum Daily Loads (TMDLs) for pollutants on the 303(d) list. TMDLs establish wasteload allocations for point sources and load allocations for non-point sources to achieve the water quality standards for the impaired water bodies.

Central San Francisco Bay is listed as impaired by chlordane, DDT, dieldrin, invasive species, dioxins and furans, mercury, PCBs, and selenium. On February 12, 2008, USEPA approved a TMDL for mercury in the San Francisco Bay. On March 29, 2010, USEPA approved a TMDL for PCBs in San Francisco Bay. The TMDLs for mercury and PCBs are incorporated into the Basin Plan and apply to this discharge. Mercury and PCBs discharges from the Plant are regulated by Regional Water Board Order No. R2-2012-0096.

IV. RATIONALE FOR EFFLUENT LIMITATIONS AND DISCHARGE SPECIFICATIONS

The CWA requires point source dischargers to control the amount of conventional, non-conventional, and toxic pollutants discharged into waters of the United States. The control of pollutants discharged is established through effluent limitations and other requirements in NPDES permits. There are two principal bases for effluent limitations in the NPDES regulations: 40 CFR 122.44(a) requires that permits include applicable technology-based limitations and standards; and 40 CFR 122.44(d) requires that permits include water quality-based effluent limitations (WQBELs) to attain and maintain applicable numeric and narrative water quality criteria to protect the beneficial uses of the receiving water.

Several specific factors affecting the development of limitations and requirements in this Order are discussed below:

A. Discharge Prohibitions

- 1. Discharge Prohibition III.A (No discharge other than as described):** This prohibition is based on 40 CFR 122.21(a), "Duty to Apply," and CWC section 13260, which requires filing an application and Report of Waste Discharge before a discharge can occur. Discharges not described in the permit application and Report of Waste Discharge, and subsequently in this Order, are prohibited.
- 2. Discharge Prohibition III.B (Minimum initial dilution of 88:1):** The Order provides a dilution credit of 88:1 in the calculation of one or more WQBELs, based on information of dilution achieved by the Discharger's current outfall. Therefore, this prohibition is necessary to ensure that the assumptions used to derive the dilution credit remain substantially the same so the limitations are protective of water quality.
- 3. Discharge Prohibition III.C (Bypass or overflow of untreated or partially treated wastewaters to waters of the U.S. is prohibited, except as provided for in section I.G of Attachment D):** This prohibition is based on 40 CFR 122.41(m) (see Federal Standard Provisions, Attachment D, section I.G). Bypass is prohibited when the influent flow is at or below 2.3 MGD (the peak wet weather flow capacity of the Plant). When influent flow is above 2.3 MGD and onsite storage has been optimized, bypass is approved for the portion of the flow above 2.3 MGD. Under these conditions, excess flows may bypass secondary treatment and be blended with the secondary-treated flow. All flows are to be disinfected prior to discharge and comply with all effluent limitations.

- a. *Bypass is unavoidable to prevent loss of life, personal injury, or severe property damage.* The Plant's reliable secondary treatment process capacity is 2.3 MGD. When primary effluent flows are above 2.3 MGD for a sustained period and onsite storage reaches capacity, blending occurs to prevent a washout of microbial populations, which are critical to achieving compliance with secondary treatment standards. Blending also prevents sewer backups and overflows in basements or on city streets.
- b. *There are no feasible alternatives to the bypass.* The Discharger has no feasible alternative at this time but to continue wet weather blending. Provision VI.C.5.a of this Order sets forth specific, feasible tasks for the Discharger to implement during this Order's term to further reduce the need to blend. During the previous order term, the Discharger implemented feasible measures to reduce the volume, duration, and occurrence of wet weather blending events (see section II.F of this Fact Sheet). To determine feasible actions for this Order's term, the Discharger completed a *No Feasible Alternatives Analysis* memo dated February 17, 2013, revised May 7, 2013, using criteria identified in USEPA's proposed guidance on *NPDES Requirements for Peak Wet Weather Discharges from POTW Treatment Plants Serving Separate Sanitary Sewer Collection Systems* (December 2005).

The *No Feasible Alternatives Analysis* memo evaluated the Discharger's current approach against two alternatives: (1) upgrading secondary treatment capacity at the Plant and (2) increasing storage capacity within the collection system. It concluded that neither alternative is feasible because the Plant site is fully developed and the area's topography and land uses prohibit expansion. The Plant is adjacent to the northern Central San Francisco Bay coast. It is flanked by steep inclines to the north and east that lead to developed residential lots, and is bordered to the west by a condominium community across the street. The topography of the service area is also steep, making the sewer line gradient non-conducive to storage. There is also a lack of open space along the sewer line to locate wastewater storage vaults.

- c. *The Discharger provided notice at least ten days before the date of the bypass.* This criterion is satisfied by the Regional Water Board's public hearing regarding the adoption of this Order.
4. **Discharge Prohibition III.D (Average dry weather flow not to exceed 0.98 MGD):** This prohibition is based on the design treatment capacity of the Plant's treatment system. Exceedance of the Plant's average dry weather flow design capacity could result in lowering the reliability of achieving compliance with water quality requirements.
 5. **Discharge Prohibition III.E (No sanitary sewer overflows):** Basin Plan Discharge Prohibition 15 (Table 4-1) and the CWA prohibit the discharge of wastewater to surface waters except as authorized under an NPDES permit. Publicly owned treatment works must achieve secondary treatment at a minimum and any more stringent limitations necessary to meet water quality standards [33 U.S.C. § 1311 (b)(1)(B and C)]. A sanitary sewer overflow that results in the discharge of raw sewage, or wastewater not meeting this Order's effluent limitations, to surface waters is therefore prohibited under the CWA and the Basin Plan.

B. Conventional and Non-Conventional Pollutant Limitations

1. Scope and Authority

CWA section 301(b) and 40 CFR 122.44 require that permits include conditions meeting technology-based requirements, at a minimum, and any more stringent effluent limitations necessary to meet applicable water quality standards. The discharge authorized by this Order must meet the minimum federal technology-based requirements based on Secondary Treatment Standards at 40 CFR 133, which are summarized below. The 30-day average percent removal for BOD₅ and TSS, by concentration, is not to be less than 85 percent. The Basin Plan contains additional requirements for certain pollutants.

Table F-7. Secondary Treatment Requirements

Parameters	Monthly Average	Weekly Average
BOD ₅	30 mg/L	45 mg/L
TSS	30 mg/L	45 mg/L
pH	6.0 – 9.0 standard units	

2. Effluent Limitations for Conventional and Non-conventional Pollutants

- a. **BOD₅ and TSS.** The secondary treatment standards require the effluent limitations for BOD₅ and TSS, including the 85 percent removal efficiency.
- b. **pH.** Secondary treatment standards and Basin Plan Table 4-2 require pH effluent limitations for deep water dischargers to be 6.0 to 9.0 standard units.
- c. **Oil and Grease.** Basin Plan Table 4-2 requires effluent limitations for oil and grease to be a monthly average effluent limitation of 10 mg/L and a maximum daily effluent limitation of 20 mg/L.
- d. **Total Chlorine Residual.** Basin Plan Table 4-2 requires an instantaneous effluent limitation for residual chlorine of 0.0 mg/L. The allowance for determining false positives using continuous devices is based on the fact that continuous instruments occasionally have anomalous spikes, and it is chemically improbable to have free chlorine present in the presence of sodium bisulfite.
- e. **Enterococcus Bacteria.** Basin Plan Table 4-2A requires an enterococcus bacteria effluent limitation of 35 MPN/100 mL as a five sample geometric mean. Since the MRP requires a sampling frequency of 5/Month for initial three months and allows a reduced frequency of 4/Year depending on the results of the first three months, this Order establishes the effluent limitation for enterococcus bacteria as the geometric mean of all samples collected within a calendar month.
- f. **Total Coliform Organisms.** Central San Francisco Bay's beneficial uses include shellfish harvesting; therefore, Basin Plan Table 4-2A requires total coliform effluent limitations of 10,000 MPN/100 mL as a daily maximum effluent limitation and 240 MPN/100 mL as a monthly median. Basin Plan Table 4-2A specifies 240 MPN/100 mL as a five-sample median. Since the MRP requires weekly sampling, expressing the limit as a monthly median

is roughly equivalent and simplifies reporting if additional samples are collected within a particular month.

C. Water Quality-Based Effluent Limitations (WQBELs) for Toxic Substances

WQBELs have been derived for toxic pollutants to implement water quality objectives that protect beneficial uses. The procedures for calculating individual WQBELs are based on the SIP and the Basin Plan.

1. Scope and Authority

- a. NPDES regulations at 40 CFR 122.44(d)(1)(i) mandate that permits include effluent limitations for all pollutants that are or may be discharged at levels that have reasonable potential to cause or contribute to an excursion of a water quality standard, including numeric and narrative objectives within a standard. As specified in 40 CFR 122.44(d)(1)(i), permits are required to include WQBELs for all pollutants “which the Director determines are or may be discharged at a level which will cause, have the reasonable potential to cause, or contribute to an excursion above any state water quality standard.”

The process for determining “reasonable potential” and calculating WQBELs when necessary is intended to protect the designated beneficial uses of the receiving water as specified in the Basin Plan, and achieve applicable water quality objectives contained in the CTR, NTR, and other state plans and policies.

- b. NPDES regulations and the SIP provide the basis to establish Maximum Daily Effluent Limitations (MDELs) and Average Monthly Effluent Limitations (AMELs).
 - (1) NPDES regulations at 40 CFR 122.45(d) state, “For continuous discharges all permit effluent limitations, standards, and prohibitions, including those necessary to achieve water quality standards, shall *unless impracticable* be stated as MDELs and AMELs for all discharges other than publicly owned treatment works.”
 - (2) SIP section 1.4 requires WQBELs to be expressed as MDELs and AMELs.
- c. MDELs are used in this Order to protect against acute water quality effects. The MDELs are necessary to prevent fish kills or mortality to aquatic organisms.

2. Applicable Beneficial Uses and Water Quality Objectives

The water quality objectives applicable to the receiving water for this discharge are from the Basin Plan; the CTR, established by USEPA at 40 CFR 131.38; and the NTR, established by USEPA at 40 CFR 131.36. Some pollutants have water quality objectives from more than one of these sources.

- a. **Basin Plan.** The Basin Plan specifies numeric water quality objectives for 10 priority toxic pollutants, as well as narrative water quality objectives for toxicity and bioaccumulation in order to protect beneficial uses. The pollutants for which the Basin Plan specifies numeric objectives are arsenic, cadmium, chromium (VI), copper in marine and freshwater, lead, mercury, nickel, silver, zinc, and cyanide. The narrative toxicity objective states, “All waters shall be maintained free of toxic substances in concentrations that are lethal to or that

produce other detrimental responses in aquatic organisms.” The bioaccumulation objective states, “Controllable water quality factors shall not cause a detrimental increase in concentrations of toxic substances found in bottom sediments or aquatic life. Effects on aquatic organisms, wildlife, and human health will be considered.” Effluent limitations and provisions contained in this Order implement these objectives based on available information.

- b. CTR.** The CTR specifies numeric aquatic life criteria for 23 priority toxic pollutants and numeric human health criteria for 57 priority toxic pollutants. These criteria apply to all inland surface waters and enclosed bays and estuaries of the San Francisco Bay Region, although Basin Plan Tables 3-3 and 3-4 include numeric objectives for certain of these priority toxic pollutants that supersede CTR criteria. Human health criteria are further identified as for “water and organisms” and for “organisms only.” The CTR criteria applicable to “organisms only” apply to the receiving water because it is not a source of drinking water.
- c. NTR.** The NTR establishes numeric aquatic life criteria for selenium and numeric human health criteria for 33 toxic organic pollutants for waters of San Francisco Bay upstream to and including Suisun Bay and the Sacramento River-San Joaquin River Delta.
- d. Sediment Quality Objectives.** The *Water Quality Control Plan for Enclosed Bays and Estuaries – Part 1, Sediment Quality* contains a narrative water quality objective, “Pollutants in sediments shall not be present in quantities that, alone or in combination, are toxic to benthic communities in bays and estuaries of California.” This water quality objective is to be implemented by integrating three lines of evidence: sediment toxicity, benthic community condition, and sediment chemistry. The policy requires that if the Regional Water Board determines that a discharge has reasonable potential to cause or contribute to an exceedance of this water quality objective, it is to impose the water quality objective as a receiving water limit.
- e. Basin Plan Receiving Water Salinity Policy.** The Basin Plan (like the CTR and the NTR) states that the salinity characteristics (i.e., freshwater vs. saltwater) of the receiving water are to be considered in determining the applicable water quality objectives. Freshwater criteria apply to discharges to waters with salinities equal to or less than one part per thousand (ppt) at least 95 percent of the time. Saltwater criteria apply to discharges to waters with salinities equal to or greater than 10 ppt at least 95 percent of the time in a normal water year. For discharges to water with salinities between these two categories, or tidally influenced freshwaters that support estuarine beneficial uses, the water quality objectives are the lower of the salt or freshwater water quality objectives (the latter calculated based on ambient hardness) for each substance.

The receiving water for this discharge is Raccoon Strait of Central San Francisco Bay, a marine water body based on salinity data collected by the San Francisco Estuary Institute (SFEI) Regional Monitoring Program (RMP). Salinity data collected from February 1993 to August 2001 at the Richardson Bay station (BC30), the RMP monitoring location nearest to the discharge point, indicate that the salinity was less than 1 ppt zero percent of the time and greater than 10 ppt in 100 percent of the time. Raccoon Strait is therefore classified as marine, and the reasonable potential analysis and effluent limitations in this Order are based on saltwater water quality objectives.

- f. **Receiving Water Hardness.** Salt water criteria are not hardness dependent; therefore, hardness is not considered in the Reasonable Potential Analysis.
- g. **Site-Specific Metals Translators.** NPDES regulations at 40 CFR 122.45(c) require that effluent limitations for metals be expressed as total recoverable metal. Since applicable water quality objectives for metals are typically expressed as dissolved metal, translators must be used to convert metals concentrations from dissolved to total recoverable and vice versa. The CTR includes default translators; however, site-specific conditions, such as water temperature, pH, suspended solids, and organic carbon greatly affect the form of metal (dissolved, non-filterable, or otherwise) present in the water and therefore available to cause toxicity. In general, the dissolved form of the metal is more available and more toxic to aquatic life than non-filterable forms. Site-specific translators can be developed to account for site-specific conditions, thereby preventing exceedingly stringent or under protective water quality objectives.

Basin Plan Table 7.2.1-2 establishes site-specific metal translators for copper as 0.73 (AMEL) and 0.87 (MDEL) for deep water dischargers to Central San Francisco Bay. For nickel, site-specific translators of 0.65 (AMEL) and 0.85 (MDEL) are available for deep water discharges to Central San Francisco Bay based on *North of Dumbarton Bridge Copper and Nickel Development and Selection of Final Translators* (Clean Estuary Partnership, March 2005). CTR default translators were used for all other metals.

3. Determining the Need for WQBELs

Assessing whether a pollutant has reasonable potential to exceed a water quality objective in the water body is the fundamental step in determining whether or not a WQBEL is required.

a. Reasonable Potential Methodology

For priority pollutants and most other toxic pollutants, the reasonable potential analysis (RPA) identifies the observed maximum effluent concentration (MEC) for each pollutant based on effluent concentration data. There are three triggers in determining reasonable potential according to SIP section 1.3:

- (1) Trigger 1 is activated if the MEC is greater than or equal to the lowest applicable water quality objective ($MEC \geq$ water quality objective), which has been adjusted, if appropriate, for pH, hardness, and translator data. If the MEC is greater than or equal to the adjusted water quality objective, then that pollutant has reasonable potential, and a WQBEL is required.
- (2) Trigger 2 is activated if the observed maximum ambient background concentration (B) is greater than the adjusted water quality objective ($B >$ water quality objective) and the pollutant is detected in any of the effluent samples.
- (3) Trigger 3 is activated if a review of other information determines that a WQBEL is required to protect beneficial uses, even though both MEC and B are less than the water quality objective.

b. Effluent Data

The nature of the discharge was analyzed to determine if the discharge has reasonable potential. The RPA is based on effluent monitoring data the Discharger collected from September 2008 through December 2012.

c. Ambient Background Data

The SIP states that, for calculating WQBELs, ambient background concentrations are either the observed maximum ambient water column concentrations or, for objectives intended to protect human health from carcinogenic effects, the arithmetic mean of observed ambient water concentrations.

For priority pollutants, the ambient background values include (1) RMP data collected from 1993 through 2009 at the Yerba Buena Island RMP station (BC10) and (2) monitoring data the Bay Area Clean Water Agencies (BACWA) collected from 2002 through 2004 (*San Francisco Bay Ambient Water Monitoring Interim Report, 2003, and Ambient Water Monitoring: Final CTR Sampling Update, June 2004*).

For ammonia, the RPA was conducted and WQBELs were calculated using RMP data from 1994 through 2001 at the Richardson Bay Station (BC30).

d. RPA for Toxic Pollutants

The MECs, most stringent applicable water quality objectives, and background concentrations used in the RPA are presented in the following table, along with the RPA results (yes or no) for each pollutant. Reasonable potential was not determined for all pollutants because there are not applicable water quality objectives for all pollutants and monitoring data are not available for others. Based on a review of the effluent data collected during the previous order term from September 2008 through December 2012, the pollutants that exhibit reasonable potential at Discharge Point No. 001 are copper, cyanide, and ammonia by Trigger 1, and dioxin-TEQ by Trigger 2.

Table F-8. Reasonable Potential Analysis Summary

CTR #	Priority Pollutants	Governing Water Quality Objective (µg/L)	MEC or Minimum DL ^{[1][2]} (µg/L)	Maximum Background or Minimum DL ^{[1][2]} (µg/L)	RPA Results ^[3]
1	Antimony	4,300	0.43	1.8	No
2	Arsenic	36	1.70	2.46	No
3	Beryllium	No Criteria	<0.041	0.22	No
4	Cadmium	3.37	0.03	0.13	No
5a	Chromium (III)	644	1.2	4.4	No
5b	Chromium, Total	11	1.0	4.4	No
6	Copper	8.2	12	2.5	Yes
7	Lead	8.5	0.21	0.8	No
8	Mercury (303(d) listed)	.. ^[4]	.. ^[4]	.. ^[4]	No
9	Nickel	13	12	3.7	No
10	Selenium (303(d) listed)	5.0	1.4	0.39	No
11	Silver	2.2	0.063	0.052	No
12	Thallium	6.3	<0.05	0.21	No
13	Zinc	86	54	5.1	No
14	Cyanide	2.9	11	<0.4	Yes
15	Asbestos	No Criteria	Not Available	Not Available	No
16	2,3,7,8-TCDD (303(d) listed)	1.4 x 10 ⁻⁸	Not Available	8.2x10 ⁻⁹	No

CTR #	Priority Pollutants	Governing Water Quality Objective (µg/L)	MEC or Minimum DL ^{[1][2]} (µg/L)	Maximum Background or Minimum DL ^{[1][2]} (µg/L)	RPA Results ^[3]
	Dioxin TEQ (303(d) listed)	1.4×10^{-8}	1.0×10^{-9}	5.32×10^{-8}	Yes
17	Acrolein	780	<1.7	<0.50	No
18	Acrylonitrile	0.66	<0.69	0.03	No
19	Benzene	71	<0.18	<0.05	No
20	Bromoform	360	2.2	<0.5	No
21	Carbon Tetrachloride	4.4	0.2	0.06	No
22	Chlorobenzene	21,000	<0.18	<0.5	No
23	Chlorodibromomethane	34	1.9	<0.05	No
24	Chloroethane	No Criteria	<0.38	<0.5	No
25	2-Chloroethylvinyl ether	No Criteria	<0.28	<0.5	No
26	Chloroform	No Criteria	2.7	<0.5	No
27	Dichlorobromomethane	46	1.9	<0.05	No
28	1,1-Dichloroethane	No Criteria	<0.19	<0.05	No
29	1,2-Dichloroethane	99	<0.18	0.04	No
30	1,1-Dichloroethylene	3.2	<0.21	<0.5	No
31	1,2-Dichloropropane	39	<0.18	<0.05	No
32	1,3-Dichloropropylene	1,700	<0.16	<0.5	No
33	Ethylbenzene	29,000	<0.26	<0.5	No
34	Methyl Bromide	4,000	<0.17	<0.5	No
35	Methyl Chloride	No Criteria	<0.23	<0.5	No
36	Methylene Chloride	1,600	<0.20	22	No
37	1,1,2,2-Tetrachloroethane	11	<0.10	<0.05	No
38	Tetrachloroethylene	8.85	<0.19	<0.05	No
39	Toluene	200,000	0.40	<0.3	No
40	1,2-Trans-Dichloroethylene	140,000	0.22	<0.5	No
41	1,1,1-Trichloroethane	No Criteria	<0.19	<0.5	No
42	1,1,2-Trichloroethane	42	<0.16	<0.05	No
43	Trichloroethylene	81	<0.20	<0.5	No
44	Vinyl Chloride	525	<0.25	<0.5	No
45	2-Chlorophenol	400	<0.98	<1.2	No
46	2,4-Dichlorophenol	790	<0.99	<1.3	No
47	2,4-Dimethylphenol	2,300	<0.87	<1.3	No
48	2-Methyl- 4,6-Dinitrophenol	765	<0.91	<1.2	No
49	2,4-Dinitrophenol	14,000	<0.83	<0.7	No
50	2-Nitrophenol	No Criteria	<0.89	<1.3	No
51	4-Nitrophenol	No Criteria	<0.83	<1.6	No
52	3-Methyl 4-Chlorophenol	No Criteria	<0.91	<1.1	No
53	Pentachlorophenol	3.31	<0.81	<1	No
54	Phenol	4,600,000	<0.69	<1.3	No
55	2,4,6-Trichlorophenol	6.5	<0.97	<1.3	No
56	Acenaphthene	2,700	<0.03	0.0019	No
57	Acenaphthylene	No Criteria	<0.03	0.0013	No
58	Anthracene	110,000	<0.03	0.00059	No
59	Benzidine	0.00054	<5.0	<0.0015	No
60	Benzo(a)Anthracene	0.049	<0.03	0.0053	No
61	Benzo(a)Pyrene	0.049	<0.03	0.0033	No
62	Benzo(b)Fluoranthene	0.049	<0.03	0.0046	No
63	Benzo(ghi)Perylene	No Criteria	<0.03	0.0045	No
64	Benzo(k)Fluoranthene	0.049	<0.03	0.0018	No
65	Bis(2-Chloroethoxy)Methane	No Criteria	<0.93	<0.3	No
66	Bis(2-Chloroethyl)Ether	1.4	<0.95	<0.00015	No
67	Bis(2-Chloroisopropyl)Ether	170000	<0.81	Not Available	No
68	Bis(2-Ethylhexyl) Phthalate	5.9	1.94	<0.7	No
69	4-Bromophenyl Phenyl Ether	No Criteria	<0.97	<0.23	No
70	Butylbenzyl Phthalate	5,200	<0.98	0.0056	No

CTR #	Priority Pollutants	Governing Water Quality Objective (µg/L)	MEC or Minimum DL ^{[1][2]} (µg/L)	Maximum Background or Minimum DL ^{[1][2]} (µg/L)	RPA Results ^[3]
71	2-Chloronaphthalene	4,300	<0.98	<0.3	No
72	4-Chlorophenyl Phenyl Ether	No Criteria	<0.99	<0.3	No
73	Chrysene	0.049	<0.03	0.0028	No
74	Dibenzo(a,h)Anthracene	0.049	<0.03	0.00064	No
75	1,2-Dichlorobenzene	17,000	<0.27	<0.3	No
76	1,3-Dichlorobenzene	2,600	<0.18	<0.3	No
77	1,4-Dichlorobenzene	2,600	<0.18	<0.3	No
78	3,3 Dichlorobenzidine	0.077	<5.0	<0.001	No
79	Diethyl Phthalate	120,000	<0.86	<0.21	No
80	Dimethyl Phthalate	2,900,000	<0.97	<0.21	No
81	Di-n-Butyl Phthalate	12,000	<0.91	0.016	No
82	2,4-Dinitrotoluene	9.1	<0.96	<0.27	No
83	2,6-Dinitrotoluene	No Criteria	<0.98	<0.29	No
84	Di-n-Octyl Phthalate	No Criteria	<0.92	<0.38	No
85	1,2-Diphenylhydrazine	0.54	<0.90	0.0037	No
86	Fluoranthene	370	<0.03	0.011	No
87	Fluorene	14000	<0.03	0.0021	No
88	Hexachlorobenzene	0.00077	<0.91	0.000022	No
89	Hexachlorobutadiene	50	<0.92	<0.3	No
90	Hexachlorocyclopentadiene	17,000	<0.90	<0.3	No
91	Hexachloroethane	8.9	<0.94	<0.2	No
92	Indeno(1,2,3-cd)Pyrene	0.049	<0.03	0.0040	No
93	Isophorone	600	<0.93	<0.3	No
94	Naphthalene	No Criteria	<0.03	0.013	No
95	Nitrobenzene	1900	<0.95	<0.25	No
96	N-Nitrosodimethylamine	8.1	<0.88	<0.3	No
97	N-Nitrosodi-n-Propylamine	1.4	<0.97	<0.001	No
98	N-Nitrosodiphenylamine	16	<0.83	<0.001	No
99	Phenanthrene	No Criteria	<0.03	0.0095	No
100	Pyrene	11,000	<0.03	0.019	No
101	1,2,4-Trichlorobenzene	No Criteria	<0.98	<0.3	No
102	Aldrin	0.00014	<0.003	2.8x10 ⁻⁶	No
103	Alpha-BHC	0.013	<0.002	0.00050	No
104	Beta-BHC	0.046	<0.002	0.00041	No
105	Gamma-BHC	0.063	<0.002	0.00070	No
106	Delta-BHC	No Criteria	<0.002	0.000053	No
107	Chlordane (303(d) listed)	0.00059	<0.005	0.00018	No
108	4,4'-DDT (303(d) listed)	0.00059	<0.003	0.00017	No
109	4,4'-DDE (linked to DDT)	0.00059	<0.003	0.00069	No
110	4,4'-DDD	0.00084	<0.003	0.00031	No
111	Dieldrin (303d listed)	0.00014	<0.003	0.00026	No
112	Alpha-Endosulfan	0.0087	<0.003	0.000031	No
113	beta-Endosulfan	0.0087	<0.003	0.000069	No
114	Endosulfan Sulfate	240	<0.003	0.000082	No
115	Endrin	0.0023	<0.003	0.000040	No
116	Endrin Aldehyde	0.81	<0.002	Not Available	No
117	Heptachlor	0.00021	<0.003	0.000019	No
118	Heptachlor Epoxide	0.00011	<0.003	0.000094	No
119-125	PCBs sum (303(d) listed)	_[4]	_[4]	_[4]	No
126	Toxaphene	0.0002	<0.20	Not Available	No
	Tributyltin	0.0074	NA	0.0022	No
	Total PAHs	15	NA	0.084	No
	Total Ammonia (in mg/L as nitrogen)	1.19	30	0.174	Yes

Footnotes:

- ^[1] The maximum effluent concentration (MEC) and maximum background concentration are the actual detected concentrations unless preceded by a “<” sign, in which case the value shown is the minimum detection level (DL).
- ^[2] The MEC or maximum background concentration is “Not Available” when there are no monitoring data for the constituent.
- ^[3] RPA Results = Yes, if MEC > WQC, B > WQC and MEC is detected, or Trigger 3;
= No, if MEC and B are < WQC or all effluent data are undetected;
= Undetermined (Ud), if no criteria have been promulgated or there are insufficient data.
- ^[4] SIP section 1.3 excludes from its RPA procedure priority pollutants for which a TMDL has been developed. TMDLs have been developed for mercury and PCBs in San Francisco Bay. Mercury and PCBs from wastewater discharges are regulated by NPDES Permit No. CA0038849 (currently Regional Water Board Order No. R2-2012-0096), which implements the San Francisco Bay Mercury and PCB TMDLs.

- e. Constituents with limited data.** In some cases, reasonable potential cannot be determined because effluent data are limited or ambient background concentrations are unavailable. Provision VI.C.2 requires the Discharger to continue monitoring these constituents in the effluent using analytical methods that provide the best feasible detection limits. When additional data become available, further RPA will be conducted to determine whether numeric effluent limitations are necessary.
- f. Pollutants with No Reasonable Potential.** WQBELs are not included in this Order for constituents that do not demonstrate reasonable potential; however, monitoring for those pollutants is still required. If concentrations of these constituents are found to have increased significantly, Provision VI.C.2 requires the Discharger to investigate the sources of the increases. Remedial measures are required if the increases pose a threat to receiving water quality.
- g. RPA for Sediment Quality Objective.** Pollutants in some receiving water sediments may be present in quantities that alone or in combination are toxic to benthic communities. Efforts are underway to identify stressors causing such conditions. However, to date there is no evidence directly linking compromised sediment conditions to the discharges subject to this Order; therefore the Regional Water Board cannot draw a conclusion about reasonable potential for the discharges to cause or contribute to exceedances of the sediment quality objectives. Nevertheless, the Discharger continues to participate in the RMP, which monitors San Francisco Bay sediment and seeks to identify stressors responsible for degraded sediment quality. Thus far, the monitoring has provided only limited information about potential stressors and sediment transport. The Regional Water Board is exploring options for obtaining additional information that may inform future RPAs.

4. WQBEL Calculations

- a. Pollutants with Reasonable Potential.** WQBELs were developed for the toxic and priority pollutants determined to have reasonable potential to cause or contribute to exceedances of the water quality objectives. The WQBELs were calculated based on water quality objectives and the procedures specified in SIP section 1.4. The water quality objectives used for each pollutant with reasonable potential are discussed below.
- b. Dilution Credit.** The SIP allows dilution credits for completely-mixed discharges and, under certain circumstances, for incompletely-mixed discharges. The Discharger submitted a *Near-field Dilution Modeling Study*, dated September 26, 2007, using the Cornell Mixing Zone Expert System for multi-port diffusers (CORMIX2). The study found a dilution factor of 83:1 for a maximum daily wet weather effluent flow rate of 21.5 MGD (acute) and a dilution factor of 88:1 for a 4-day maximum wet weather flow rate of 16.4 MGD (chronic).

Flowrates used in the modeling were based on combined effluent discharges from the Sewerage Agency of Southern Marin and Sanitary District No. 5 of Marin County.

- (i) **Bioaccumulative Pollutants:** For certain bioaccumulative pollutants, dilution credit is significantly restricted or denied. Specifically, these pollutants include chlordane, DDT, dieldrin, dioxin compounds, furan compounds, mercury, PCBs, selenium, and dioxin-like PCBs, which all appear on the CWA section 303(d) list for Central San Francisco Bay because, based on available data on concentration of these pollutants in aquatic organisms, sediment, and the water column, they impair San Francisco Bay beneficial uses. The following factors suggest insufficient assimilative capacity in San Francisco Bay for these pollutants.

Tissue samples taken from fish in San Francisco Bay show the presence of these pollutants at concentrations greater than screening levels (*Contaminant Concentrations in Fish from San Francisco Bay*, May 1997). The results of a 1994 San Francisco Bay pilot study, presented in *Contaminated Levels in Fish Tissue from San Francisco Bay* (Regional Water Board, 1994) also showed elevated levels of chemical contaminants in fish tissues. The Office of Environmental Health and Hazard Assessment completed a preliminary review of the data in the 1994 report and in December 1994 issued an interim consumption advisory covering certain fish species in San Francisco Bay due to the levels of some of these pollutants. The Office of Environmental Health Hazard Assessment updated this advisory by issuing its May 2011 report Health Advisory and Safe Eating Guidelines for San Francisco Bay Fish and Shellfish, which still suggests insufficient assimilative capacity in San Francisco Bay for 303(d)-listed pollutants. Therefore, dilution credits are denied for bioaccumulative pollutants on the 303(d) list for which data are lacking on sources and significant uncertainty about how different sources of these pollutants contribute to bioaccumulation.

- (ii) **Non-Bioaccumulative Pollutants:** For non-bioaccumulative pollutants (except ammonia), a conservative dilution allowance of 10:1 ($D = 9$) has been assigned. The 10:1 dilution allowance is consistent with the previous order and is based, in part, on Basin Plan Prohibition 1 (Table 4-1), which prohibits discharges with less than 10:1 dilution. SIP section 1.4.2 allows for limiting the dilution credit. The dilution credit is limited for the following reasons:
- (a) San Francisco Bay is a very complex estuarine system with highly variable and seasonal upstream freshwater inflows and diurnal tidal saltwater inputs. SIP section 1.4.3 allows background conditions to be determined on a discharge-by-discharge or water body-by-water body basis. A water body-by-water body basis approach is taken here due to inherent uncertainties in characterizing ambient background conditions in a complex estuarine system on a discharge-by-discharge basis. The Yerba Buena Island RMP monitoring station, relative to other RMP stations, fits SIP guidance criteria for establishing background conditions. The SIP requires that background water quality data be representative of the ambient receiving water that will mix with the discharge. Water quality data from the Yerba Buena Island RMP monitoring station is representative of the water that will mix with the discharge.
- (b) Because of the complex hydrology of San Francisco Bay, there are uncertainties in accurately determining an appropriate mixing zone. The models used to predict

dilution do not consider the three-dimensional nature of San Francisco Bay currents resulting from the interaction of tidal flushes and seasonal fresh water outflows. Being heavier and colder than fresh water, ocean salt water enters San Francisco Bay on a twice-daily tidal cycle, generally beneath the warmer fresh water that flows seaward. When these waters mix and interact, complex circulation patterns occur due to the varying densities of the fresh and ocean waters. The complex patterns occur throughout San Francisco Bay, but are most prevalent in the San Pablo Bay, Carquinez Strait, and Suisun Bay areas. The locations of this mixing and interaction change, depending on the strength of each tide. Additionally, sediment loads from the Central Valley change on a long-term basis, affecting the depth of different parts of San Francisco Bay, resulting in alteration of flow patterns, mixing, and dilution at the outfall.

- (iii) **Ammonia.** For ammonia, a conservative estimated actual initial dilution was used to calculate the effluent limitations. This is justified because ammonia, a non-persistent pollutant, quickly disperses and degrades to a non-toxic state, and cumulative toxicity effects are unlikely. As described above, the Discharger used CORMIX2 and estimated actual initial dilution ratio to be 83:1 (D = 82) for a maximum daily flow of 21.5 MGD (acute) and 88:1 (D = 87) for a 4-day maximum flow of 16.4 MGD (chronic).

c. Development of WQBELs for Specific Pollutants

(1) Copper

- (a) **Water Quality Objectives.** The Basin Plan contains site-specific chronic and acute marine water quality objectives for copper of 6.0 micrograms per liter ($\mu\text{g/L}$) and 9.4 $\mu\text{g/L}$, expressed as dissolved metal. These objectives were converted to total recoverable metal using the site-specific translators of 0.73 (chronic) and 0.87 (acute), as described in section IV.C.2.g of this Fact Sheet. The resulting chronic and acute criteria are 8.2 $\mu\text{g/L}$ and 10.8 $\mu\text{g/L}$.
- (b) **RPA Results.** This Order establishes effluent limitations for copper because the MEC (12 $\mu\text{g/L}$) exceeds the governing water quality objective (8.2 $\mu\text{g/L}$), demonstrating reasonable potential by Trigger 1. Reasonable potential is also established by Trigger 3, consistent with Basin Plan section 7.2, which requires that individual NPDES permits for municipal and industrial wastewater treatment facilities include copper WQBELs.
- (c) **WQBELs.** WQBELs for copper, calculated according to SIP procedures using an effluent data coefficient of variation (CV) of 0.28 and a dilution credit of 10:1 (D = 9), are an AMEL of 54 $\mu\text{g/L}$ and an MDEL of 73 $\mu\text{g/L}$.
- (d) **Anti-backsliding.** Anti-backsliding requirements are satisfied because the copper limitations are the same as those in the previous order.

(2) Cyanide

- (a) **Water Quality Objectives.** The Basin Plan contains site-specific chronic and acute marine water quality objectives for cyanide of 2.9 $\mu\text{g/L}$ and 9.4 $\mu\text{g/L}$.

- (b) **RPA Results.** This Order establishes effluent limitations for cyanide because the MEC (11 µg/L) exceeds the governing water quality objective (2.9 µg/L), demonstrating reasonable potential by Trigger 1. Reasonable potential is also established by Trigger 3, consistent with Basin Plan section 4.7.2.2, which requires that individual NPDES permits for municipal and industrial wastewater treatment facilities include cyanide WQBELs.
- (c) **WQBELs.** WQBELs for cyanide, calculated according to SIP procedures using a CV of 0.88 and a dilution credit of 10:1 (D = 9), are an AMEL of 19 µg/L and an MDEL of 46 µg/L. The previous order contained an AMEL of 20 µg/L and an MDEL of 45 µg/L. This Order establishes an AMEL of 19 µg/L using the newly calculated limit and retains the previous order's more stringent MDEL of 45 µg/L.
- (d) **Anti-backsliding.** Anti-backsliding requirements are satisfied because the cyanide limitations are at least as stringent as those in the previous order.

(3) Dioxin – TEQ

- (a) **Water Quality Objective.** The Basin Plan narrative water quality objective for bioaccumulative substances states, “Many pollutants can accumulate on particulates, in sediments, or bioaccumulate in fish and other aquatic organisms. Controllable water quality factors shall not cause a detrimental increase in concentrations of toxic substances found in bottom sediments or aquatic life. Effects on aquatic organisms, wildlife, and human health will be considered.”

Because it is the consensus of the scientific community that dioxins and furans associate with particulates, accumulate in sediments, and bioaccumulate in the fatty tissue of fish and other organisms, the Basin Plan's narrative bioaccumulation water quality objective is applicable to these pollutants. Elevated levels of dioxins and furans in fish tissue in San Francisco Bay demonstrate that the narrative bioaccumulation water quality objective is not being met. USEPA has therefore included Central San Francisco Bay as impaired by dioxin and furan compounds in the current 303(d) listing of receiving waters, where water quality objectives are not being met after imposition of applicable technology-based requirements.

The CTR establishes a numeric water quality objective for 2,3,7,8-tetrachlorinated dibenzo-p-dioxin (2,3,7,8-TCDD) of 1.4×10^{-8} µg/L for the protection of human health, when aquatic organisms are consumed. When the CTR was promulgated, USEPA stated its support of the regulation of other dioxin and dioxin-like compounds through the use of toxicity equivalencies (TEQs) in NPDES permits. For California waters, USEPA stated specifically, “... if the discharge of dioxin or dioxin-like compounds has reasonable potential to cause or contribute to a violation of a narrative criterion, numeric water quality based effluent limits for dioxin or dioxin-like compounds should be included in NPDES permits and should be expressed using a TEQ scheme” (65 Fed. Reg. 31682, 31695 [2000]).

This Order uses a TEQ scheme based on a set of toxicity equivalency factors (TEFs) the World Health Organization (WHO) developed in 1998, and a set of bioaccumulation equivalency factors (BEFs) USEPA developed for the Great Lakes

region (40 CFR 132, Appendix F) to convert the concentration of any congener of dioxin or furan into an equivalent concentration of 2,3,7,8-TCDD. The CTR criterion is used as a criterion for dioxin-TEQ because dioxin-TEQ represents a toxicity weighted concentration equivalent to 2,3,7,8-TCDD, thus translating the narrative bioaccumulation objective into a numeric criterion appropriate for the RPA.

To determine if the discharge of dioxin or dioxin-like compounds has reasonable potential, TEFs and BEFs were used to express the measured concentrations of 16 dioxin congeners in effluent and background samples as 2,3,7,8-TCDD. These “equivalent” concentrations were then compared to the CTR numeric criterion for 2,3,7,8-TCDD (1.4×10^{-8} $\mu\text{g/L}$). Although the 1998 WHO scheme includes TEFs for dioxin-like PCBs, they are not included in this Order’s TEQ scheme. The CTR has established a specific water quality standard for PCBs, and dioxin-like PCBs are included in the analysis of total PCBs.

- (b) **RPA Results.** This Order establishes effluent limitations for dioxin-TEQ because the background dioxin value (5.3×10^{-8} $\mu\text{g/L}$) exceeds the governing translated narrative water quality objective (1.4×10^{-8} $\mu\text{g/L}$) and dioxin-TEQ has been detected in the effluent, indicating reasonable potential by Trigger 2. Because the dioxin-TEQ in the discharge could cause or contribute to exceedance of the Basin Plan’s bioaccumulation water quality objective, there is also reasonable potential based on Trigger 3.
- (c) **WQBELs.** WQBELs for dioxin-TEQ, calculated according to SIP procedures with a default CV of 0.6 and no dilution credit, are an AMEL of 1.4×10^{-8} $\mu\text{g/L}$ and an MDEL of 2.8×10^{-8} $\mu\text{g/L}$.
- (d) **Anti-backsliding.** Anti-backsliding requirements are satisfied because the dioxin-TEQ limitations are the same as those in the previous order.

(4) Ammonia

- (a) **Water Quality Objectives.** The Basin Plan contains water quality objectives for un-ionized ammonia (as nitrogen) of 0.025 mg/L as an annual median and 0.16 mg/L as a maximum upstream of the San Francisco Bay Bridge. These Water quality objectives were translated from un-ionized ammonia concentrations to equivalent total ammonia concentrations (as nitrogen) since (1) sampling and laboratory methods are not available to analyze for un-ionized ammonia; and (2) the fraction of total ammonia that exists in the toxic un-ionized form depends on the pH, salinity, and temperature of the receiving water.

To translate the Basin Plan un-ionized ammonia objective, Regional Water Board staff used pH, salinity, and temperature data from 1993 through 2001 from the nearest RMP station to the outfall, the Richardson Bay RMP Station (BC30). Regional Water Board staff used the following equations to determine the fraction of total ammonia that would exist in the toxic un-ionized form in the marine receiving water where the various measurements were taken from 1994-2001 (USEPA, 1989, Ambient Water Quality Criteria for Ammonia (Saltwater)–1989, EPA Publication 440/5-88-004):

$$\text{For salinity } > 10 \text{ ppt: fraction of NH}_3 = \frac{1}{1 + 10^{(pK - pH)}}$$

Where:

$$pK = 9.245 + 0.116(I) + 0.0324(298 - T) + \frac{0.0415(P)}{(T)}$$

$$I = \text{Molal ionic strength of saltwater} = \frac{19.9273(S)}{(1,000 - 1.005109(S))}$$

S = Salinity (parts per thousand)

T = Temperature in degrees Kelvin

P = Pressure (one atmosphere)

The 90th percentile and median un-ionized ammonia fractions were then used to express the daily maximum and the annual average un-ionized objectives as acute and chronic total ammonia objectives, respectively. This approach is consistent with USEPA guidance on translating dissolved metal water quality objectives to total recoverable metal water quality objectives (USEPA, 1996, *The Metals Translator: Guidance for Calculating a Total Recoverable Limit from a Dissolved Criterion*, EPA Publication 823-B-96-007.)

The equivalent total ammonia acute and chronic water quality objectives are 4.58 mg/L and 1.19 mg/L, respectively.

- (b) **RPA Results.** Basin Plan section 4.5.5.2 indicates that WQBELs are to be calculated for toxic pollutants according to the SIP. Basin Plan section 3.3.20 refers to ammonia as a toxic pollutant. Using these Basin Plan sections as guidance, therefore, the SIP methodology was used to perform the RPA and to calculate effluent limitations for ammonia. This Order establishes effluent limitations for total ammonia because the MEC of 30 mg/L (as nitrogen) exceeds the governing translated water quality objective for this pollutant (1.19 mg/L), demonstrating reasonable potential by Trigger 1.
- (c) **WQBELs.** Total ammonia WQBELs were calculated separately for acute and chronic conditions. Statistical adjustments were made to the calculations because:
- the Basin Plan’s chronic water quality objective for un-ionized ammonia is based on an annual median instead of the typical 4-day average; and
 - the SIP assumes a 4-day average concentration and a monthly sampling frequency of 4 days per month to calculate effluent limitations based on chronic criteria, whereas a 365-day average and a monitoring frequency of 30 days per month (the maximum daily sampling frequency in a month since the averaging period for the chronic criteria is longer than 30 days) were used.

These statistical adjustments are supported by USEPA's *Water Quality Criteria; Notice of Availability; 1999 Update of Ambient Water Quality Criteria for Ammonia*, published on December 22, 1999, in the Federal Register. Following the SIP methodology, the maximum ambient background total ammonia concentration (0.174 mg/L) was used to calculate effluent limitations based on the acute criterion, and the median background total ammonia concentration (0.080 mg/L) was used to calculate effluent limitations based on the chronic criterion. Because the Basin Plan's chronic un-ionized ammonia objective is an annual median, the median background concentration is more representative of ambient conditions than a daily maximum.

The WQBELs for the acute water quality objective, calculated according to SIP procedures using a CV of 0.3 and an acute dilution credit of 83:1 (D=82), are an AMEL of 230 mg/L and an MDEL of 370 mg/L. The WQBELs for the chronic water quality objective, calculated using a CV of 0.3 and a chronic dilution credit of 88:1 (D=87), are an AMEL of 120 mg/L and an MDEL of 190 mg/L. The previous order contained an AMEL of 100 mg/L and an MDEL of 210 mg/L. This Order retains the previous order's more stringent AMEL of 100 mg/L and establishes an MDEL of 190 mg/L using the newly calculated limit for the chronic condition.

- (d) **Anti-backsliding.** Anti-backsliding requirements are satisfied because the ammonia limits are at least as stringent as those in the previous order.
- (e) **Growing Regional Concern with Nutrients.** As described above, a translated Basin Plan un-ionized ammonia objective and a conservative initial dilution were used to calculate the total ammonia effluent limitations. In the future, the Regional Water Board may grant less dilution credit or change the ammonia limitations in other ways to address growing concerns about nutrients in the receiving water. Currently, a region-wide effort is underway to study and evaluate potential effects. This effort, which is referred to as the San Francisco Bay Nutrient Strategy, includes developing a nutrient assessment framework that can be used to calculate WQBELs for nutrients. The Regional Water Board, through its Executive Officer, has also required wastewater dischargers, including this Discharger, to monitor nutrients, including ammonia, in their influent and effluent. This information will be used to compare nutrient loads from wastewater discharges to loads from other sources, to support modeling and evaluation of load reduction scenarios, and to determine the need for additional wastewater treatment to address nutrients.

d. Effluent Limit Calculations

The following table shows the WQBEL calculations for copper, cyanide, dioxin-TEQ, and total ammonia:

Table F-9. WQBEL Calculations

Pollutant	Copper	Cyanide	Dioxin-TEQ	Total Ammonia (acute)	Total Ammonia (chronic)
Units	µg/L	µg/L	µg/L	mg/L-N	mg/L-N
Basis and Criteria Type	BP SSOs	BP SSOs	BP narrative	BP aquatic life	BP aquatic life
Criteria – Acute	3.9	9.4	--	4.58	--
Criteria – Chronic	2.5	2.9	--	--	1.19
HH criteria	---	2.2E+05	1.4E-08	--	--
Water Effects Ratio	2.4	1	1	1	1
Lowest WQO	2.5	2.9	1.4E-08	4.58	1.19
Site Specific Translator - MDEL	0.87	---	---	---	--
Site Specific Translator – AMEL	0.73	---	---	---	---
Dilution Factor (D)	9	9	0	82	87
No. of samples per month	4	4	4	5	5
Aquatic life analysis required?	Y	Y	N	Y	Y
HH analysis required?	N	Y	Y	N	N
Applicable Acute WQO	10.8	9.4	---	4.58	---
Applicable Chronic WQO	8.2	2.9	---	---	1.19
Background	2.55	0.4	5.32E-08	0.174	0.080
Is the pollutant on the 303(d) list?	N	N	Y	N	N
ECA acute	84.6	90.4	---	365.9	---
ECA chronic	59.3	25.4	---	---	97.8
ECA human health	---	2.2E+06	1.4E-08	---	---
No. of data points <10, or at least 80% non-detect	N	N	Y	N	N
Average effluent concentration	5.68	3.0	1.1E-10	16.72	16.72
Standard Deviation	1.60	2.7	3.3E-10	5.73	5.73
CV calculated	0.28	0.88	0.6	0.34	0.34
CV selected	0.28	0.88	0.6	0.34	0.34
ECA acute mult99	0.55	0.23	--	0.49	---
ECA chronic mult99	0.73	0.41	--	---	0.96
LTA acute	46.26	20.7	--	178.3	---
LTA chronic	43.20	10.4	--	---	93.8
Minimum LTA	43.20	10.4	--	178.3	93.8
AMEL mult95	1.25	1.8	1.55	1.3	1.3
MDEL mult99	1.83	4.4	3.11	2.1	2.1
AMEL aquatic life	53.86	19	--	226	119
MDEL aquatic life	79.04	46	--	366	193
MDEL/AMEL multiplier	1.47	2.4	2.0	1.6	1.6

Pollutant	Copper	Cyanide	Dioxin-TEQ	Total Ammonia (acute)	Total Ammonia (chronic)
Units	µg/L	µg/L	µg/L	mg/L-N	mg/L-N
AMEL human health	--	2.2E+06	1.4E-08	--	--
MDEL human health	--	5.3E+06	2.8E-08	--	--
Calculated AMEL	54	19	1.4E-08	226	119
Calculated MDEL	79	46	2.8E-08	366	193
Previous Order AMEL	54	20	1.4E-08	100	100
Previous Order MDEL	73	45	2.8E-08	210	210
Final limit - AMEL	54	19	1.4E-08	100	100
Final limit - MDEL	73	45	2.8E-08	190	190

5. Whole Effluent Acute Toxicity

This Order includes effluent limitations for whole effluent acute toxicity based on Basin Plan Table 4-3. Compliance is evaluated based on 96-hour continuous flow-through bioassays (see MRP section V.A). All bioassays are to be performed according to the USEPA approved method in 40 CFR 136, currently *Methods for Measuring the Acute Toxicity of Effluents and Receiving Waters to Freshwater and Marine Organisms*, 5th Edition.

As allowed by Basin Plan section 4.5.5.3.1, the Order does not consider toxicity exceeding effluent levels to be a violation if the toxicity is caused by ammonia. The ammonia limits in this Order are based on receiving water conditions are sufficient to prevent acute toxicity in the receiving water.

6. Whole Effluent Chronic Toxicity

- a. **Toxicity Objective.** Basin Plan section 3.3.18 states, “There shall be no chronic toxicity in ambient waters. Chronic toxicity is a detrimental biological effect on growth rate, reproduction, fertilization success, larval development, population abundance, community composition, or any other relevant measure of the health of an organism, population, or community.”
- b. **Reasonable Potential Analysis.** The previous order included a chronic toxicity trigger of 10 TUc as a single-sample maximum, which would trigger accelerated chronic toxicity testing if exceeded. During the previous order term, chronic toxicity testing using mysid shrimp (*Americamysis bahia*) indicated that the maximum single-sample chronic toxicity was 3.4 TUc. This relatively low toxicity indicates low reasonable potential for chronic toxicity so this Order contains only a narrative chronic toxicity limit. A numeric limit is unwarranted.
- c. **Permit Requirements.** Chronic toxicity requirements are based on the narrative Basin Plan toxicity objective. The Discharger is to monitor and test for chronic toxicity as described in MRP section V.B.
- d. **Screening Phase Study and Monitoring Requirement.** In May 2012, the Discharger submitted the results of species sensitivity screening conducted to evaluate the appropriate

species for chronic toxicity tests. Two species were identified were sensitive for sub-lethal effects, *Americamysis bahia* and *Ceriodaphnia dubia*. During the testing *Ceriodaphnia dubia* was slightly more sensitive; however, the additional toxicity was attributed to the salinity of the Discharger's effluent. Using a marine species, such as *Americamysis bahia*, is preferable due to the salinity of the effluent and the receiving water. Thus, this Order specifies *Americamysis bahia* as the chronic toxicity test species. The Discharger is required to conduct another chronic toxicity screening phase study as described in MRP Appendix E-1 prior to the next permit issuance.

The accelerated monitoring triggers are based on Basin Plan Table 4-5 and consistent with the previous order.

7. Antidegradation

NPDES regulations at 40 CFR 131.12 require that State water quality standards include an antidegradation policy consistent with federal policy. The State Water Board established California's antidegradation policy through State Water Board Resolution No. 68-16, which incorporates federal policy where federal policy applies. Resolution No. 68-16 requires that existing water quality be maintained unless degradation is justified based on specific findings. The Basin Plan implements, and incorporates by reference, both State and federal antidegradation policies.

The permitted discharge is consistent with the antidegradation provisions of 40 CFR 131.12 and State Water Board Resolution No. 68-16. With the exception of how this Order addresses selenium and bis(2-ethylhexyl) phthalate (discussed below), this Order continues the status quo with respect to the level of discharge authorized in the previous order and thus there will be no change in water quality beyond the level authorized in the previous order. The limitations in this Order comply with antidegradation requirements because they hold the Discharger to performance levels that will neither cause nor contribute to water quality impairment nor further water quality degradation. This is because this Order does not provide for an increase in the permitted design flow, allow for a reduced level of treatment, or increase effluent limitations.

This Order does not retain the selenium and bis(2-ethylhexyl) phthalate limits from the previous order because there is no reasonable potential for the discharge to contribute to an exceedance of the water quality objectives for selenium or bis(2-ethylhexyl) phthalate. Plant operations are not expected to change based on the removal of these effluent limitations. Influent and effluent concentrations are expected to remain within their historic norms; thus, the removal of these limitations is not expected to increase selenium and bis(2-ethylhexyl) phthalate discharges to the receiving water. Because there will be no lowering of water quality beyond the current level authorized in the previous order, which is the baseline by which to measure whether degradation will occur, findings authorizing degradation are unnecessary. The discharge is consistent with 40 CFR 131.12 and State Board Resolution No. 68-16.

V. RATIONALE FOR RECEIVING WATER LIMITATIONS

Receiving water limitations V.A and V.B in the Order are based on the narrative and numeric objectives contained in Basin Plan Chapter 3. Receiving water limitation V.C is retained from the previous order and requires compliance with federal and State water quality standards.

VI. RATIONALE FOR MONITORING AND REPORTING REQUIREMENTS

The MRP is a standard requirement in almost all NPDES permits issued by the Regional Water Board, including this Order. It contains definitions of terms and sets out requirements for reporting routine monitoring data in accordance with NPDES regulations, the CWC, and State and Regional Water Board policies. The MRP also defines the sampling stations and frequency, the pollutants to be monitored, and additional reporting requirements. Pollutants to be monitored include all parameters for which effluent limitations are specified. Monitoring for additional constituents, for which no effluent limitations are established, is also required to provide data for future completion of RPAs.

The following provides the rationale for the monitoring and reporting requirements contained in the MRP for this facility:

A. Influent Monitoring

Influent monitoring requirements at INF-001 for BOD₅ and TSS are unchanged from the previous order to allow determination of compliance with this Order's 85% removal requirement. Flow monitoring is also retained to evaluate compliance with Prohibition III.D (average dry weather flow). Influent cyanide monitoring has been added based on section 4.7.2 of the Basin Plan.

B. Effluent Monitoring

The MRP retains most effluent monitoring requirements at Monitoring Locations EFF-001 and EFF-001D from the previous order. Changes in effluent monitoring are summarized as follows:

- A new monitoring location (EFF-001B) was established to monitor effluent discharges during blending events. During blending events, additional monitoring at EFF-001B will be required consistent with Attachment G, section III.A.3.b.6.
- Monitoring for enterococcus bacteria has been established to determine compliance with new effluent limitations. Basin Plan Table 4-2A, footnote a, specifies that the enterococcus limit "shall be implemented as a geometric mean of a minimum of 5 effluent samples spaced over a calendar month." It further states that fewer samples may be used on a case-by-case basis. If after three months the Discharger has demonstrated full compliance with the enterococcus effluent limitation, the MRP allows the Discharger to reduce its enterococcus monitoring frequency to four times per year.
- Monthly monitoring for selenium and bis(2-ethylhexyl) phthalate has been removed because this Order does not contain effluent limitations for these pollutants; however, they will continue to be monitored as part of the Effluent Characterization Study specified in section VI.C.2 of the Order.
- Monitoring for the remaining priority pollutants is still required under the Effluent Characterization Study specified in section VI.C.2 of the Order.

C. Whole Effluent Toxicity Testing Requirements

1. **Acute Toxicity.** Monthly 96-hour bioassay testing is required to demonstrate compliance with the effluent limitation for acute toxicity. The MRP requires the use of either the fathead minnow or rainbow trout as the bioassay test species.

2. Chronic Toxicity. This Order establishes a requirement for the Discharger to conduct chronic toxicity testing twice a year to ensure the discharge has acceptable low levels of chronic toxicity. The Discharger conducted an effluent toxicity screening study during the previous order term. The study concluded that the *Americamysis bahia* (mysid shrimp) was the most sensitive marine species. The permit, therefore, requires the use of *Americamysis bahia* as the chronic toxicity test species. The Discharger is to re-screen in accordance with MRP Appendix E-1 after any significant change in the nature of the effluent or prior to submittal of the application for permit reissuance, due April 3, 2018. The Discharger has an option to complete the screening on its own or in conjunction with other local dischargers.

D. Receiving Water Monitoring

The Discharger is required to continue participating in the San Francisco Estuary Institute’s Regional Monitoring Program (RMP), which involves collection of data on pollutants and toxicity in San Francisco Bay water, sediment, and biota. The Discharger’s participation and support of the RMP is the basis for not including other receiving water monitoring requirements in this permit.

VII. RATIONALE FOR PROVISIONS

A. Standard Provisions (Provision VI.A)

Standard Provisions, which in accordance with 40 CFR 122.41 and 122.42 apply to all NPDES discharges and must be included in every NPDES permit, are provided in Attachments D. NPDES regulations at 40 CFR 122.41(a)(1) and (b) through (n) establish conditions that apply to all state-issued NPDES permits. These conditions must be incorporated into the permits either expressly or by reference. NPDES regulations at 40 CFR 123.25(a)(12) allow the state to omit or modify conditions to impose more stringent requirements. The Regional Standard Provisions (Attachment G) supplement the Federal Standard Provisions. In accordance with 40 CFR 123.25, this Order omits federal conditions that address enforcement authority specified in 40 CFR 122.41(j)(5) and (k)(2) because the CWC enforcement authority is more stringent. In lieu of these conditions, this Order incorporates by reference CWC section 13387(e).

B. Monitoring and Reporting Requirements (Provision VI.B)

The Discharger is required to monitor the permitted discharges in order to evaluate compliance with permit conditions. Monitoring requirements are contained in the MRP, and Attachments D and G. This provision requires compliance with these documents and is authorized by 40 CFR 122.41(h) and (j), and CWC sections 13267 and 13383.

The table below summarizes routine monitoring requirements. This table is for informational purposes only. Actual requirements are specified in the MRP and other applicable provisions of this Order.

Table F-10. Monitoring Requirements Summary

Parameter	Influent INF-001	Effluent EFF-001 or EFF-001D	Effluent EFF-001B (during blending)	Sludge and Biosolids BIO-001	Receiving Water
Flow	Continuous	Continuous	Continuous	--	--
BOD	1/Week	1/Week	1/Year ^[1]	--	--

Parameter	Influent INF-001	Effluent EFF-001 or EFF-001D	Effluent EFF-001B (during blending)	Sludge and Biosolids BIO-001	Receiving Water
TSS	1/Week	1/Week	1/Day	--	--
Oil and Grease	--	1/Quarter	--	--	--
pH	--	Continuous	1/Year ^[1]	--	Support RMP
Chlorine Residual	--	Continuous or 1/2 Hour	1/Year ^[1]	--	--
Total Coliform	--	1/Week	1/Day	--	Support RMP
Enterococcus	--	5/Month	1/Day	--	Support RMP
Copper	--	1/Month	1/Year ^[1]	--	Support RMP
Cyanide	2/Year	1/Month	1/Year ^[1]	--	Support RMP
Dioxin-TEQ	--	1/Year	--	--	Support RMP
Ammonia	--	1/Month	1/Year ^[1]	--	Support RMP
All Other Priority Pollutants	--	1/Year	--	--	Support RMP
Acute Toxicity	--	1/Month	--	--	Support RMP
Chronic Toxicity	--	1/Year	--	--	Support RMP
Standard Observations	--	1/Month	--	--	--
Metric tons/year	--	--	--	See Att. G § III.B.1	--
Paint filter test	--	--	--	See Att. G § III.B.2	--

Footnotes:

^[1] If a TSS sample collected on the same day exceeds 45 mg/L, the frequency shall be once per day.

The principal purposes of a monitoring program are to:

- Document compliance with waste discharge requirements and prohibitions established by the Regional Water Board,
- Facilitate self-policing by the Discharger in the prevention and abatement of pollution arising from waste discharge,
- Develop or assist in the development of limitations, discharge prohibitions, national standards of performance, pretreatment and toxicity standards, and other standards, and
- Prepare water and wastewater quality inventories.

C. Special Provisions (Provision VI.C)

1. Reopener Provisions

These provisions are based on 40 CFR 122.63 and allow modification of this Order and its effluent limitations as necessary in response to updated water quality standards, regulations, or other new relevant information that may become available in the future and other circumstances allowed by law.

2. Effluent Characterization Study and Report

This Order does not include effluent limitations for priority pollutants that do not demonstrate reasonable potential, but this provision requires the Discharger to continue monitoring for these pollutants as described in the Regional Standard Provisions (Attachment G) and as specified in the MRP. This requirement is authorized pursuant to CWC section 13267 and is necessary to

inform the next permit reissuance and to ensure that the Discharger takes proper and timely steps in response to any changes in unanticipated effluent quality during the term of this Order.

3. **Best Management Practices and Pollutant Minimization Program**

This provision for a Pollutant Minimization Program is based on Basin Plan section 4.13.2 and SIP section 2.4.5.

4. **Special Provisions for POTWs**

- a. **Biosolids Management Practices.** This provision is based on Basin Plan Chapter 4, section 4.17, and 40 CFR Parts 257 and 503.
- b. **Sanitary Sewer Overflows and Sewer System Management Plan.** This provision is to explain the Order's requirements as they relate to the Discharger's collection system, and to promote consistency with the State Water Board's General Waste Discharge Requirements for Sanitary Sewer Overflows and related Monitoring and Reporting Program (Order No. 2006-0003-DWQ) (General Order).

The General Order requires public agencies that own or operate sanitary sewer systems with greater than one mile of pipes or sewer lines to enroll for coverage under the General Order. The General Order requires agencies to develop sanitary sewer management plans and report all sanitary sewer overflows, among other requirements and prohibitions. Furthermore, the General Order contains requirements for the operation and maintenance of collection systems and for reporting and mitigating sanitary sewer overflows. Inasmuch that the Discharger's collection system is part of the system that is subject to this Order, certain standard provisions apply as specified in Provisions, section VI.C.4.b., Sanitary Sewer Overflows and Sewer System Management Plan. The Discharger must comply with both the General Order and this Order. The Discharger was required to enroll under the General Order by December 1, 2006.

The State Water Board amended the General Order on February 20, 2008, in Order No. WQ2008-0002-EXEC, to strengthen the notification and reporting requirements for sanitary sewer overflows. The Regional Standard Provisions (Attachment G) contains the same notification and reporting requirements for spills from wastewater treatment facilities.

5. **Other Special Provisions**

- a. **Specific Tasks to Improvement Wet Weather Management and Reduce Blending.** This provision is based on 40 CFR 122.41(m) and guidance provided by USEPA's proposed *NPDES Permit Requirements for Peak Wet Weather Discharges from Publicly Owned Treatment Works Treatment Plants Serving Separate Sanitary Sewer Collection Systems* (December 2005). It contains feasible tasks that can be taken within the term of this Order to improve wet weather management and reduce blending. During the previous order term, the Discharger implemented numerous measures to reduce blending, as summarized in section II.F of this Fact Sheet. This provision expands on these efforts. This provision does not include tasks that address satellite collection systems because there are none.

One of the tasks is a requirement to submit a new No Feasible Alternatives Analysis with the application for permit reissuance. USEPA's proposed guidance suggests specific analyses for the Discharger to complete in order to determine whether its peak wet weather flow blending discharge should be considered a bypass under 40 CFR 122.41(m) and whether any feasible alternatives to blending are available. These analyses are intended to address the criteria for approving a bypass at 40 CFR 122.41(m)(4)(i)(A)-(C). The Regional Water Board will use the new No Feasible Alternatives Analysis to review and approve or deny peak wet weather bypasses. If these criteria are met and no feasible alternative exists, the Regional Water Board may approve peak wet weather flow diversions around secondary treatment units in an NPDES permit for discharges from a municipal treatment plant as an anticipated bypass under 40 CFR 122.41(m)(4)(ii).

- b. Copper Action Plan.** This provision is based on Basin Plan section 7.2.1.2. It is necessary to ensure that use of copper site-specific objectives is consistent with antidegradation policies. Data that the San Francisco Estuary Institute compiled for 2008-2010 indicate no degradation of San Francisco Bay water quality with respect to copper (<http://www.sfei.org/content/copper-site-specific-objective-3-year-rolling-averages>).
- c. Cyanide Action Plan.** This provision is based on Basin Plan section 4.7.2.2. It is necessary to ensure that use of cyanide site-specific objectives is consistent with antidegradation policies. The threshold for considering influent cyanide concentrations to indicate a possible "significant cyanide discharge" in the Discharger's service area is set at 30 µg/L. This concentration is about 10 percent higher than the maximum cyanide concentration (27 µg/L) found in the Plant's influent during the term of the previous order. Because influent cyanide concentrations the Discharger observed during the previous period ranged from 0.9 µg/L to 27 µg/L, with a median of 2.6 µg/L and a 99th percentile of 26 µg/L, influent concentrations higher than 30 µg/L could indicate a significant cyanide source.

VIII. PUBLIC PARTICIPATION

The Regional Water Board considered the issuance of these waste discharge requirements (WDRs) that will serve as an NPDES permit for the Facility's discharges. As a step in the WDR adoption process, Regional Water Board staff developed tentative WDRs. The Regional Water Board encouraged public participation in the WDR adoption process.

A. Notification of Interested Parties

The Regional Water Board notified the Discharger and interested agencies and persons of its intent to prescribe WDRs for the discharge and provided them with an opportunity to submit written comments and recommendations. Notification was provided through the Marin Independent Journal.

B. Written Comments

Staff determinations are tentative. Interested persons were invited to submit written comments concerning these tentative WDRs. Comments were to be submitted either in person or by mail to the Executive Officer at the Regional Water Board at 1515 Clay Street, Suite 1400, Oakland, California 94612, to the attention of Marcia Liao.

To receive full consideration and a written response, written comments were to be received at the Regional Water Board offices by 5:00 p.m. on June 24, 2013.

C. Public Hearing

The Regional Water Board held a public hearing on the tentative WDRs during its regular meeting at the following date and time, and at the following location:

Date: August 14, 2013
Time: 9:00 am
Location: Elihu Harris State Office Building
1515 Clay Street, 1st Floor Auditorium
Oakland, CA 94612

Contact: Marcia Liao, (510) 622-2377, email Marcia.Liao@waterboards.ca.gov

Interested persons were invited to attend. At the public hearing, the Regional Water Board heard testimony, if any, pertinent to the discharge, WDRs, and permit. Oral testimony was heard; however, for accuracy of the record, important testimony was to be in writing.

Dates and venues change. The Regional Water Board web address is <http://www.waterboards.ca.gov/sanfranciscobay>, where one could access the current agenda for changes in dates and locations.

D. Waste Discharge Requirements Petitions

Any aggrieved person may petition the State Water Board to review the decision of the Regional Water Board regarding the final WDRs. The petition must be submitted within 30 days of the Regional Water Board's action to the following address:

State Water Resources Control Board
Office of Chief Counsel
P.O. Box 100, 1001 I Street
Sacramento, CA 95812-0100

E. Information and Copying

The Report of Waste Discharge (RWD), related documents, tentative effluent limitations, and special provisions, comments received, and other information are on file and may be inspected at the address above at any time between 9:00 a.m. and 5:00 p.m., Monday through Friday. Copying of documents may be arranged by calling 510-622-2300.

F. Register of Interested Persons

Any person interested in being placed on the mailing list for information regarding the WDRs and NPDES permit should contact the Regional Water Board, reference this facility, and provide a name, address, and phone number.

G. Additional Information

Requests for additional information or questions regarding this Order should be directed to Marcia Liao at 510-622-2377 or e-mail at Marcia.Liao@waterboards.ca.gov.

**CALIFORNIA REGIONAL WATER QUALITY CONTROL BOARD
SAN FRANCISCO BAY REGION**

**ATTACHMENT G
REGIONAL STANDARD PROVISIONS, AND MONITORING
AND REPORTING REQUIREMENTS
(SUPPLEMENT TO ATTACHMENT D)**

For

NPDES WASTEWATER DISCHARGE PERMITS

March 2010

Contents

I. STANDARD PROVISIONS - PERMIT COMPLIANCE G-1

 A. Duty to Comply..... G-1

 B. Need to Halt or Reduce Activity Not a Defense..... G-1

 C. Duty to Mitigate..... G-1

 1. Contingency Plan G-1

 2. Spill Prevention Plan..... G-2

 D. Proper Operation & Maintenance G-2

 1. Operation and Maintenance (O&M) Manual..... G-2

 2. Wastewater Facilities Status Report G-2

 3. Proper Supervision and Operation of Publicly Owned Treatment Works (POTWs)G-3

 E. Property Rights G-3

 F. Inspection and Entry G-3

 G. Bypass G-3

 H. Upset G-3

 I. Other G-3

 J. Stormwater..... G-3

 1. Stormwater Pollution Prevention Plan (SWPP Plan)..... G-3

 2. Source Identification..... G-4

 3. Stormwater Management Controls G-5

 4. Annual Verification of SWPP Plan..... G-6

 K. Biosolids Management..... G-6

II. STANDARD PROVISIONS – PERMIT ACTION G-7

III. STANDARD PROVISIONS – MONITORING G-7

 A. Sampling and Analyses..... G-7

 1. Use of Certified Laboratories..... G-7

 2. Use of Appropriate Minimum Levels G-7

 3. Frequency of Monitoring G-7

 B. Biosolids Monitoring G-10

 1. Biosolids Monitoring Frequency G-10

 2. Biosolids Pollutants to Monitor G-11

 C. Standard Observations G-11

 1. Receiving Water Observations G-11

 2. Wastewater Effluent Observations G-11

 3. Beach and Shoreline Observations G-12

 4. Land Retention or Disposal Area Observations..... G-12

 5. Periphery of Waste Treatment and/or Disposal Facilities Observations G-12

IV. STANDARD PROVISIONS – RECORDS..... G-12

 A. Records to be Maintained G-12

 B. Records of monitoring information shall include G-13

 1. Analytical Information..... G-13

 2. Flow Monitoring Data..... G-13

 3. Wastewater Treatment Process Solids G-13

 4. Disinfection Process..... G-13

5. Treatment Process Bypasses	G-14
6. Treatment Facility Overflows	G-14
V. STANDARD PROVISIONS – REPORTING.....	G-14
A. Duty to Provide Information.....	G-14
B. Signatory and Certification Requirements.....	G-14
C. Monitoring Reports	G-15
1. Self Monitoring Reports	G-15
D. Compliance Schedules	G-19
E. Twenty-Four Hour Reporting	G-19
1. Spill of Oil or Other Hazardous Material Reports	G-19
2. Unauthorized Discharges from Municipal Wastewater Treatment Plants.....	G-20
F. Planned Changes	G-23
G. Anticipated Noncompliance.....	G-23
H. Other Noncompliance	G-23
I. Other Information	G-23
VI. STANDARD PROVISIONS – ENFORCEMENT.....	G-23
VII. ADDITIONAL PROVISIONS – NOTIFICATION LEVELS	G-23
VIII. DEFINITIONS – This section is an addition to Standard Provisions (Attachment D)	G-23

**CALIFORNIA REGIONAL WATER QUALITY CONTROL BOARD
SAN FRANCISCO BAY REGION**

**REGIONAL STANDARD PROVISIONS, AND MONITORING AND
REPORTING REQUIREMENTS
(SUPPLEMENT TO ATTACHMENT D)**

FOR

NPDES WASTEWATER DISCHARGE PERMITS

APPLICABILITY

This document applies to dischargers covered by a National Pollutant Discharge Elimination System (NPDES) permit. This document does not apply to Municipal Separate Storm Sewer System (MS4) NPDES permits.

The purpose of this document is to supplement the requirements of Attachment D, Standard Provisions. The requirements in this supplemental document are designed to ensure permit compliance through preventative planning, monitoring, recordkeeping, and reporting. In addition, this document requires proper characterization of issues as they arise, and timely and full responses to problems encountered. To provide clarity on which sections of Attachment D this document supplements, this document is arranged in the same format as Attachment D.

I. STANDARD PROVISIONS - PERMIT COMPLIANCE

A. Duty to Comply – Not Supplemented

B. Need to Halt or Reduce Activity Not a Defense – Not Supplemented

C. Duty to Mitigate – This supplements I.C. of Standard Provisions (Attachment D)

- 1. Contingency Plan** - The Discharger shall maintain a Contingency Plan as originally required by Regional Water Board Resolution 74-10 and as prudent in accordance with current municipal facility emergency planning. The Contingency Plan shall describe procedures to ensure that existing facilities remain in, or are rapidly returned to, operation in the event of a process failure or emergency incident, such as employee strike, strike by suppliers of chemicals or maintenance services, power outage, vandalism, earthquake, or fire. The Discharger may combine the Contingency Plan and Spill Prevention Plan into one document. Discharge in violation of the permit where the Discharger has failed to develop and implement a Contingency Plan as described below will be the basis for considering the discharge a willful and negligent violation of the permit pursuant to California Water Code Section 13387. The Contingency Plan shall, at a minimum, contain the provisions of a. through g. below.
 - a. Provision of personnel for continued operation and maintenance of sewerage facilities during employee strikes or strikes against contractors providing services.

- b. Maintenance of adequate chemicals or other supplies and spare parts necessary for continued operations of sewerage facilities.
 - c. Provisions of emergency standby power.
 - d. Protection against vandalism.
 - e. Expeditious action to repair failures of, or damage to, equipment and sewer lines.
 - f. Report of spills and discharges of untreated or inadequately treated wastes, including measures taken to clean up the effects of such discharges.
 - g. Programs for maintenance, replacement, and surveillance of physical condition of equipment, facilities, and sewer lines.
- 2. Spill Prevention Plan** - The Discharger shall maintain a Spill Prevention Plan to prevent accidental discharges and minimize the effects of such events. The Spill Prevention Plan shall:
- a. Identify the possible sources of accidental discharge, untreated or partially treated waste bypass, and polluted drainage;
 - b. Evaluate the effectiveness of present facilities and procedures, and state when they became operational; and
 - c. Predict the effectiveness of the proposed facilities and procedures, and provide an implementation schedule containing interim and final dates when they will be constructed, implemented, or operational.

This Regional Water Board, after review of the Contingency and Spill Prevention Plans or their updated revisions, may establish conditions it deems necessary to control accidental discharges and to minimize the effects of such events. Such conditions may be incorporated as part of the permit upon notice to the Discharger.

D. Proper Operation & Maintenance – This supplements I.D of Standard Provisions (Attachment D)

- 1. Operation and Maintenance (O&M) Manual** - The Discharger shall maintain an O&M Manual to provide the plant and regulatory personnel with a source of information describing all equipment, recommended operational strategies, process control monitoring, and maintenance activities. To remain a useful and relevant document, the O&M Manual shall be kept updated to reflect significant changes in treatment facility equipment and operational practices. The O&M Manual shall be maintained in usable condition and be available for reference and use by all relevant personnel and Regional Water Board staff.
- 2. Wastewater Facilities Status Report** - The Discharger shall regularly review, revise, or update, as necessary, its Wastewater Facilities Status Report. This report shall document how the Discharger operates and maintains its wastewater collection, treatment, and disposal facilities to ensure that all facilities are adequately staffed, supervised, financed, operated,

maintained, repaired, and upgraded as necessary to provide adequate and reliable transport, treatment, and disposal of all wastewater from both existing and planned future wastewater sources under the Discharger's service responsibilities.

3. **Proper Supervision and Operation of Publicly Owned Treatment Works (POTWs) -** POTWs shall be supervised and operated by persons possessing certificates of appropriate grade pursuant to Division 4, Chapter 14, Title 23 of the California Code of Regulations.

E. Property Rights – Not Supplemented

F. Inspection and Entry – Not Supplemented

G. Bypass – Not Supplemented

H. Upset – Not Supplemented

I. Other – This section is an addition to Standard Provisions (Attachment D)

1. Neither the treatment nor the discharge of pollutants shall create pollution, contamination, or nuisance as defined by California Water Code Section 13050.
2. Collection, treatment, storage, and disposal systems shall be operated in a manner that precludes public contact with wastewater, except in cases where excluding the public is infeasible, such as private property. If public contact with wastewater could reasonably occur on public property, warning signs shall be posted.
3. If the Discharger submits a timely and complete Report of Waste Discharge for permit reissuance, this permit continues in force and effect until a new permit is issued or the Regional Water Board rescinds the permit.

J. Storm Water – This section is an addition to Standard Provisions (Attachment D)

These provisions apply to facilities that do not direct all storm water flows from the facility to the wastewater treatment plant headworks.

1. Storm Water Pollution Prevention Plan (SWPP Plan)

The SWPP Plan shall be designed in accordance with good engineering practices and shall address the following objectives:

- a. To identify pollutant sources that may affect the quality of storm water discharges; and
- b. To identify, assign, and implement control measures and management practices to reduce pollutants in storm water discharges.

The SWPP Plan may be combined with the existing Spill Prevention Plan as required in accordance with Section C.2. The SWPP Plan shall be retained on-site and made available upon request of a representative of the Regional Water Board.

2. Source Identification

The SWPP Plan shall provide a description of potential sources that may be expected to add significant quantities of pollutants to storm water discharges, or may result in non-storm water discharges from the facility. The SWPP Plan shall include, at a minimum, the following items:

- a. A topographical map (or other acceptable map if a topographical map is unavailable), extending one-quarter mile beyond the property boundaries of the facility, showing the wastewater treatment facility process areas, surface water bodies (including springs and wells), and discharge point(s) where the facility's storm water discharges to a municipal storm drain system or other points of discharge to waters of the State. The requirements of this paragraph may be included in the site map required under the following paragraph if appropriate.
- b. A site map showing the following:
 - 1) Storm water conveyance, drainage, and discharge structures;
 - 2) An outline of the storm water drainage areas for each storm water discharge point;
 - 3) Paved areas and buildings;
 - 4) Areas of actual or potential pollutant contact with storm water or release to storm water, including but not limited to outdoor storage and process areas; material loading, unloading, and access areas; and waste treatment, storage, and disposal areas;
 - 5) Location of existing storm water structural control measures (i.e., berms, coverings, etc.);
 - 6) Surface water locations, including springs and wetlands; and
 - 7) Vehicle service areas.
- c. A narrative description of the following:
 - 1) Wastewater treatment process activity areas;
 - 2) Materials, equipment, and vehicle management practices employed to minimize contact of significant materials of concern with storm water discharges;
 - 3) Material storage, loading, unloading, and access areas;
 - 4) Existing structural and non-structural control measures (if any) to reduce pollutants in storm water discharges; and
 - 5) Methods of on-site storage and disposal of significant materials.
- d. A list of pollutants that have a reasonable potential to be present in storm water discharges in significant quantities.

3. Storm Water Management Controls

The SWPP Plan shall describe the storm water management controls appropriate for the facility and a time schedule for fully implementing such controls. The appropriateness and priorities of controls in the SWPP Plan shall reflect identified potential sources of pollutants. The description of storm water management controls to be implemented shall include, as appropriate:

a. Storm water pollution prevention personnel

Identify specific individuals (and job titles) that are responsible for developing, implementing, and reviewing the SWPP Plan.

b. Good housekeeping

Good housekeeping requires the maintenance of clean, orderly facility areas that discharge storm water. Material handling areas shall be inspected and cleaned to reduce the potential for pollutants to enter the storm drain conveyance system.

c. Spill prevention and response

Identify areas where significant materials can spill into or otherwise enter storm water conveyance systems and their accompanying drainage points. Specific material handling procedures, storage requirements, and cleanup equipment and procedures shall be identified, as appropriate. The necessary equipment to implement a cleanup shall be available, and personnel shall be trained in proper response, containment, and cleanup of spills. Internal reporting procedures for spills of significant materials shall be established.

d. Source control

Source controls include, for example, elimination or reduction of the use of toxic pollutants, covering of pollutant source areas, sweeping of paved areas, containment of potential pollutants, labeling of all storm drain inlets with "No Dumping" signs, isolation or separation of industrial and non-industrial pollutant sources so that runoff from these areas does not mix, etc.

e. Storm water management practices

Storm water management practices are practices other than those that control the sources of pollutants. Such practices include treatment or conveyance structures, such as drop inlets, channels, retention and detention basins, treatment vaults, infiltration galleries, filters, oil/water separators, etc. Based on assessment of the potential of various sources to contribute pollutants to storm water discharges in significant quantities, additional storm water management practices to remove pollutants from storm water discharges shall be implemented and design criteria shall be described.

f. Sediment and erosion control

Measures to minimize erosion around the storm water drainage and discharge points, such as riprap, revegetation, slope stabilization, etc., shall be described.

g. Employee training

Employee training programs shall inform all personnel responsible for implementing the SWPP Plan. Training shall address spill response, good housekeeping, and material management practices. New employee and refresher training schedules shall be identified.

h. Inspections

All inspections shall be done by trained personnel. Material handling areas shall be inspected for evidence of, or the potential for, pollutants entering storm water discharges. A tracking or follow up procedure shall be used to ensure appropriate response has been taken in response to an inspection. Inspections and maintenance activities shall be documented and recorded. Inspection records shall be retained for five years.

i. Records

A tracking and follow-up procedure shall be described to ensure that adequate response and corrective actions have been taken in response to inspections.

4. Annual Verification of SWPP Plan

An annual facility inspection shall be conducted to verify that all elements of the SWPP Plan are accurate and up-to-date. The results of this review shall be reported in the Annual Report to the Regional Water Board described in Section V.C.f.

K. Biosolids Management – This section is an addition to Standard Provisions (Attachment D)

Biosolids must meet the following requirements prior to land application. The Discharger must either demonstrate compliance or, if it sends the biosolids to another party for further treatment or distribution, must give the recipient the information necessary to ensure compliance.

1. Exceptional quality biosolids meet the pollutant concentration limits in Table III of 40 CFR Part 503.13, Class A pathogen limits, and one of the vector attraction reduction requirements in 503.33(b)(1)-(b)(8). Such biosolids do not have to be tracked further for compliance with general requirements (503.12) and management practices (503.14).
2. Biosolids used for agricultural land, forest, or reclamation shall meet the pollutant limits in Table I (ceiling concentrations) and Table II or Table III (cumulative loadings or pollutant concentration limits) of 503.13. They shall also meet the general requirements (503.12) and management practices (503.14) (if not exceptional quality biosolids) for Class A or Class B pathogen levels with associated access restrictions (503.32) and one of the 10 vector attraction reduction requirements in 503.33(b)(1)-(b)(10).
3. Biosolids used for lawn or home gardens must meet exceptional quality biosolids limits.
4. Biosolids sold or given away in a bag or other container must meet the pollutant limits in either Table III or Table IV (pollutant concentration limits or annual pollutant loading rate limits) of 503.13. If Table IV is used, a label or information sheet must be attached to the biosolids packing that explains Table IV (see 503.14). The biosolids must also meet the Class

A pathogen limits and one of the vector attraction reduction requirements in 503.33(b)(1)-(b)(8).

II. STANDARD PROVISIONS – PERMIT ACTION – Not Supplemented

III. STANDARD PROVISIONS – MONITORING

A. Sampling and Analyses – This section is a supplement to III.A and III.B of Standard Provisions (Attachment D)

1. Use of Certified Laboratories

Water and waste analyses shall be performed by a laboratory certified for these analyses in accordance with California Water Code Section 13176.

2. Use of Appropriate Minimum Levels

Table C lists the suggested analytical methods for the 126 priority pollutants and other toxic pollutants that should be used, unless a particular method or minimum level (ML) is required in the MRP.

For priority pollutant monitoring, when there is more than one ML value for a given substance, the Discharger may select any one of the analytical methods cited in Table C for compliance determination, or any other method described in 40 CFR part 136 or approved by USEPA (such as the 1600 series) if authorized by the Regional Water Board. However, the ML must be below the effluent limitation and water quality objective. If no ML value is below the effluent limitation and water quality objective, then the method must achieve an ML no greater than the lowest ML value indicated in Table C. All monitoring instruments and equipment shall be properly calibrated and maintained to ensure accuracy of measurements.

3. Frequency of Monitoring

The minimum schedule of sampling analysis is specified in the MRP portion of the permit.

a. Timing of Sample Collection

- 1) The Discharger shall collect samples of influent on varying days selected at random and shall not include any plant recirculation or other sidestream wastes, unless otherwise stipulated by the MRP.
- 2) The Discharger shall collect samples of effluent on days coincident with influent sampling unless otherwise stipulated by the MRP or the Executive Officer. The Executive Officer may approve an alternative sampling plan if it is demonstrated to be representative of plant discharge flow and in compliance with all other permit requirements.
- 3) The Discharger shall collect grab samples of effluent during periods of day-time maximum peak effluent flows (or peak flows through secondary treatment units for facilities that recycle effluent flows).

- 4) Effluent sampling for conventional pollutants shall occur on at least one day of any multiple-day bioassay test the MRP requires. During the course of the test, on at least one day, the Discharger shall collect and retain samples of the discharge. In the event a bioassay test does not comply with permit limits, the Discharger shall analyze these retained samples for pollutants that could be toxic to aquatic life and for which it has effluent limits.
 - i. The Discharger shall perform bioassay tests on final effluent samples; when chlorine is used for disinfection, bioassay tests shall be performed on effluent after chlorination-dechlorination; and
 - ii. The Discharger shall analyze for total ammonia nitrogen and calculate the amount of un-ionized ammonia whenever test results fail to meet the percent survival specified in the permit.

b. Conditions Triggering Accelerated Monitoring

- 1) If the results from two consecutive samples of a constituent monitored in a 30-day period exceed the monthly average limit for any parameter (or if the required sampling frequency is once per month and the monthly sample exceeds the monthly average limit), the Discharger shall, within 24 hours after the results are received, increase its sampling frequency to daily until the results from the additional sampling show that the parameter is in compliance with the monthly average limit.
- 2) If any maximum daily limit is exceeded, the Discharger shall increase its sampling frequency to daily within 24 hours after the results are received that indicate the exceedance of the maximum daily limit until two samples collected on consecutive days show compliance with the maximum daily limit.
- 3) If final or intermediate results of an acute bioassay test indicate a violation or threatened violation (e.g., the percentage of surviving test organisms of any single acute bioassay test is less than 70 percent), the Discharger shall initiate a new test as soon as practical, and the Discharger shall investigate the cause of the mortalities and report its findings in the next self monitoring report (SMR).
- 4) The Discharger shall calibrate chlorine residual analyzers against grab samples as frequently as necessary to maintain accurate control and reliable operation. If an effluent violation is detected, the Discharger shall collect grab samples at least every 30 minutes until compliance with the limit is achieved, unless the Discharger monitors chlorine residual continuously. In such cases, the Discharger shall continue to conduct continuous monitoring as required by its permit.
- 5) When a bypass occurs (except one subject to provision III.A.3.b.6 below), the Discharger shall monitor flows and collect samples on a daily basis for all constituents at affected discharge points that have effluent limits for the duration of the bypass (including acute toxicity using static renewals), except chronic toxicity, unless otherwise stipulated by the MRP.
- 6) Unless otherwise stipulated by the MRP, when a bypass approved pursuant to Attachment D, Standard Provisions, Sections I.G.2 or I.G.4, occurs, the Discharger

shall monitor flows and, using appropriate procedures as specified in the MRP, collect and retain samples for affected discharge points on a daily basis for the duration of the bypass. The Discharger shall analyze for total suspended solids (TSS) using 24-hour composites (or more frequent increments) and for bacteria indicators with effluent limits using grab samples. If TSS exceeds 45 mg/L in any composite sample, the Discharger shall also analyze the retained samples for that discharge for all other constituents that have effluent limits, except oil and grease, , dioxin-TEQ, and acute and chronic toxicity. Additionally, at least once each year, the Discharger shall analyze the retained samples for one approved bypass discharge event for all other constituents that have effluent limits, except oil and grease, dioxin-TEQ, and acute and chronic toxicity. This monitoring shall be in addition to the minimum monitoring specified in the MRP.

c. Storm Water Monitoring

The requirements of this section only apply to facilities that are not covered by an NPDES permit for storm water discharges and where not all site storm drainage from process areas (i.e., areas of the treatment facility where chemicals or wastewater could come in contact with storm water) is directed to the headworks. For storm water not directed to the headworks during the wet season (October 1 to April 30), the Discharger shall:

- 1) Conduct visual observations of the storm water discharge locations during daylight hours at least once per month during a storm event that produces significant storm water discharge to observe the presence of floating and suspended materials, oil and grease, discoloration, turbidity, and odor, etc.
- 2) Measure (or estimate) the total volume of storm water discharge, collect grab samples of storm water discharge from at least two storm events that produce significant storm water discharge, and analyze the samples for oil and grease, pH, TSS, and specific conductance.

The grab samples shall be taken during the first 30 minutes of the discharge. If collection of the grab samples during the first 30 minutes is impracticable, grab samples may be taken during the first hour of the discharge, and the Discharger shall explain in the Annual Report why the grab sample(s) could not be taken in the first 30 minutes.

- 3) Testing for the presence of non-storm water discharges shall be conducted no less than twice during the dry season (May 1 to September 30) at all storm water discharge locations. Tests may include visual observations of flows, stains, sludges, odors, and other abnormal conditions; dye tests; TV line surveys; or analysis and validation of accurate piping schematics. Records shall be maintained describing the method used, date of testing, locations observed, and test results.
- 4) Samples shall be collected from all locations where storm water is discharged. Samples shall represent the quality and quantity of storm water discharged from the facility. If a facility discharges storm water at multiple locations, the Discharger may sample a reduced number of locations if it establishes and documents through the monitoring program that storm water discharges from different locations are substantially identical.

- 5) Records of all storm water monitoring information and copies of all reports required by the permit shall be retained for a period of at least three years from the date of sample, observation, or report.

d. Receiving Water Monitoring

The requirements of this section only apply when the MRP requires receiving water sampling.

- 1) Receiving water samples shall be collected on days coincident with effluent sampling for conventional pollutants.
- 2) Receiving water samples shall be collected at each station on each sampling day during the period within one hour following low slack water. Where sampling during lower slack water is impractical, sampling shall be performed during higher slack water. Samples shall be collected within the discharge plume and down current of the discharge point so as to be representative, unless otherwise stipulated in the MRP.
- 3) Samples shall be collected within one foot of the surface of the receiving water, unless otherwise stipulated in the MRP.

B. Biosolids Monitoring – This section supplements III.B of Standard Provisions (Attachment D)

When biosolids are sent to a landfill, sent to a surface disposal site, or applied to land as a soil amendment, they must be monitored as follows:

1. Biosolids Monitoring Frequency

Biosolids disposal must be monitored at the following frequency:

Metric tons biosolids/365 days	Frequency
0-290	Once per year
290-1500	Quarterly
1500-15,000	Six times per year
Over 15,000	Once per month

(Metric tons are on a dry weight basis)

2. Biosolids Pollutants to Monitor

Biosolids shall be monitored for the following constituents:

Land Application: arsenic, cadmium, copper, mercury, molybdenum, nickel, lead, selenium, and zinc

Municipal Landfill: Paint filter test (pursuant to 40 CFR 258)

Biosolids-only Landfill or Surface Disposal Site (if no liner and leachate system): arsenic, chromium, and nickel

C. Standard Observations – This section is an addition to III of Standard Provisions (Attachment D)

1. Receiving Water Observations

The requirements of this section only apply when the MRP requires standard observations of the receiving water. Standard observations shall include the following:

- a. *Floating and suspended materials* (e.g., oil, grease, algae, and other macroscopic particulate matter): presence or absence, source, and size of affected area.
- b. *Discoloration and turbidity*: description of color, source, and size of affected area.
- c. *Odor*: presence or absence, characterization, source, distance of travel, and wind direction.
- d. *Beneficial water use*: presence of water-associated waterfowl or wildlife, fisherpeople, and other recreational activities in the vicinity of each sampling station.
- e. *Hydrographic condition*: time and height of corrected high and low tides (corrected to nearest National Oceanic and Atmospheric Administration location for the sampling date and time of sample collection).
- f. *Weather conditions*:
 - 1) Air temperature; and
 - 2) Total precipitation during the five days prior to observation.

2. Wastewater Effluent Observations

The requirements of this section only apply when the MRP requires wastewater effluent standard observations. Standard observations shall include the following:

- a. *Floating and suspended material of wastewater origin* (e.g., oil, grease, algae, and other macroscopic particulate matter): presence or absence.
- b. *Odor*: presence or absence, characterization, source, distance of travel, and wind direction.

3. Beach and Shoreline Observations

The requirements of this section only apply when the MRP requires beach and shoreline standard observations. Standard observations shall include the following:

- a. *Material of wastewater origin*: presence or absence, description of material, estimated size of affected area, and source.
- b. *Beneficial use*: estimate number of people participating in recreational water contact, non-water contact, or fishing activities.

4. Land Retention or Disposal Area Observations

The requirements of this section only apply to facilities with on-site surface impoundments or disposal areas that are in use. This section applies to both liquid and solid wastes, whether confined or unconfined. The Discharger shall conduct the following for each impoundment:

- a. Determine the amount of freeboard at the lowest point of dikes confining liquid wastes.
- b. Report evidence of leaching liquid from area of confinement and estimated size of affected area. Show affected area on a sketch and volume of flow (e.g., gallons per minute [gpm]).
- c. Regarding odor, describe presence or absence, characterization, source, distance of travel, and wind direction.
- d. Estimate number of waterfowl and other water-associated birds in the disposal area and vicinity.

5. Periphery of Waste Treatment and/or Disposal Facilities Observations

The requirements of this section only apply when the MRP specifies periphery standard observations. Standard observations shall include the following:

- a. *Odor*: presence or absence, characterization, source, and distance of travel.
- b. *Weather conditions*: wind direction and estimated velocity.

IV. STANDARD PROVISIONS – RECORDS

A. Records to be Maintained – This supplements IV.A of Standard Provisions (Attachment D)

The Discharger shall maintain records in a manner and at a location (e.g., wastewater treatment plant or Discharger offices) such that the records are accessible to Regional Water Board staff. The minimum period of retention specified in Section IV, Records, of the Federal Standard Provisions shall be extended during the course of any unresolved litigation regarding the subject discharge, or when requested by the Regional Water Board or Regional Administrator of USEPA, Region IX.

A copy of the permit shall be maintained at the discharge facility and be available at all times to operating personnel.

B. Records of monitoring information shall include – This supplements IV.B of Standard Provision (Attachment D)

1. Analytical Information

Records shall include analytical method detection limits, minimum levels, reporting levels, and related quantification parameters.

2. Flow Monitoring Data

For all required flow monitoring (e.g., influent and effluent flows), the additional records shall include the following, unless otherwise stipulated by the MRP:

- a. Total volume for each day; and
- b. Maximum, minimum, and average daily flows for each calendar month.

3. Wastewater Treatment Process Solids

- a. For each treatment unit process that involves solids removal from the wastewater stream, records shall include the following:
 - 1) Total volume or mass of solids removed from each collection unit (e.g., grit, skimmings, undigested biosolids, or combination) for each calendar month or other time period as appropriate, but not to exceed annually; and
 - 2) Final disposition of such solids (e.g., landfill, other subsequent treatment unit).
- b. For final dewatered biosolids from the treatment plant as a whole, records shall include the following:
 - 1) Total volume or mass of dewatered biosolids for each calendar month;
 - 2) Solids content of the dewatered biosolids; and
 - 3) Final disposition of dewatered biosolids (disposal location and disposal method).

4. Disinfection Process

For the disinfection process, these additional records shall be maintained documenting process operation and performance:

- a. For bacteriological analyses:
 - 1) Wastewater flow rate at the time of sample collection; and

- 2) Required statistical parameters for cumulative bacterial values (e.g., moving median or geometric mean for the number of samples or sampling period identified in this Order).
- b. For the chlorination process, when chlorine is used for disinfection, at least daily average values for the following:
 - 1) Chlorine residual of treated wastewater as it enters the contact basin (mg/L);
 - 2) Chlorine dosage (kg/day); and
 - 3) Dechlorination chemical dosage (kg/day).

5. Treatment Process Bypasses

A chronological log of all treatment process bypasses, including wet weather blending, shall include the following:

- a. Identification of the treatment process bypassed;
- b. Dates and times of bypass beginning and end;
- c. Total bypass duration;
- d. Estimated total bypass volume; and
- e. Description of, or reference to other reports describing, the bypass event, the cause, the corrective actions taken (except for wet weather blending that is in compliance with permit conditions), and any additional monitoring conducted.

6. Treatment Facility Overflows

This section applies to records for overflows at the treatment facility. This includes the headworks and all units and appurtenances downstream. The Discharger shall retain a chronological log of overflows at the treatment facility and records supporting the information provided in section V.E.2.

C. Claims of Confidentiality – Not Supplemented

V. STANDARD PROVISIONS – REPORTING

A. Duty to Provide Information – Not Supplemented

B. Signatory and Certification Requirements – Not Supplemented

**C. Monitoring Reports – This section supplements V.C of Standard Provisions
(Attachment D)**

1. Self Monitoring Reports

For each reporting period established in the MRP, the Discharger shall submit an SMR to the Regional Water Board in accordance with the requirements listed in this document and at the frequency the MRP specifies. The purpose of the SMR is to document treatment performance, effluent quality, and compliance with the waste discharge requirements of this Order.

a. Transmittal letter

Each SMR shall be submitted with a transmittal letter. This letter shall include the following:

- 1) Identification of all violations of effluent limits or other waste discharge requirements found during the reporting period;
- 2) Details regarding violations: parameters, magnitude, test results, frequency, and dates;
- 3) Causes of violations;
- 4) Discussion of corrective actions taken or planned to resolve violations and prevent recurrences, and dates or time schedule of action implementation (if previous reports have been submitted that address corrective actions, reference to the earlier reports is satisfactory);
- 5) Data invalidation (Data should not be submitted in an SMR if it does not meet quality assurance/quality control standards. However, if the Discharger wishes to invalidate any measurement after it was submitted in an SMR, a letter shall identify the measurement suspected to be invalid and state the Discharger's intent to submit, within 60 days, a formal request to invalidate the measurement. This request shall include the original measurement in question, the reason for invalidating the measurement, all relevant documentation that supports invalidation [e.g., laboratory sheet, log entry, test results, etc.], and discussion of the corrective actions taken or planned [with a time schedule for completion] to prevent recurrence of the sampling or measurement problem.);
- 6) If the Discharger blends, the letter shall describe the duration of blending events and certify whether blended effluent was in compliance with the conditions for blending; and
- 7) Signature (The transmittal letter shall be signed according to Section V.B of this Order, Attachment D – Standard Provisions.).

b. Compliance evaluation summary

Each report shall include a compliance evaluation summary. This summary shall include each parameter for which the permit specifies effluent limits, the number of

samples taken during the monitoring period, and the number of samples that exceed applicable effluent limits.

c. Results of analyses and observations

- 1) Tabulations of all required analyses and observations, including parameter, date, time, sample station, type of sample, test result, method detection limit, method minimum level, and method reporting level, if applicable, signed by the laboratory director or other responsible official.
- 2) When determining compliance with an average monthly effluent limitation and more than one sample result is available in a month, the Discharger shall compute the arithmetic mean unless the data set contains one or more reported determinations of detected but not quantified (DNQ) or nondetect (ND). In those cases, the Discharger shall compute the median in place of the arithmetic mean in accordance with the following procedure:
 - i. The data set shall be ranked from low to high, reported ND determinations lowest, DNQ determinations next, followed by quantified values (if any). The order of the individual ND or DNQ determinations is unimportant.
 - ii. The median value of the data set shall be determined. If the data set has an odd number of data points, then the median is the middle value. If the data set has an even number of data points, then the median is the average of the two values around the middle unless one or both of the points are ND or DNQ, in which case the median value shall be the lower of the two data points where DNQ is lower than a value and ND is lower than DNQ.

If a sample result, or the arithmetic mean or median of multiple sample results, is below the reporting limit, and there is evidence that the priority pollutant is present in the effluent above an effluent limitation and the Discharger conducts a Pollutant Minimization Program, the Discharger shall not be deemed out of compliance.

- 3) Dioxin-TEQ Reporting: The Discharger shall report for each dioxin and furan congener the analytical results of effluent monitoring, including the quantifiable limit (reporting level), the method detection limit, and the measured concentration. The Discharger shall report all measured values of individual congeners, including data qualifiers. When calculating dioxin-TEQ, the Discharger shall set congener concentrations below the minimum levels (ML) to zero. The Discharger shall calculate and report dioxin-TEQs using the following formula, where the MLs, toxicity equivalency factors (TEFs), and bioaccumulation equivalency factors (BEFs) are as provided in Table A:

$$\text{Dioxin-TEQ} = \sum (C_x \times \text{TEF}_x \times \text{BEF}_x)$$

where: C_x = measured or estimated concentration of congener x
 TEF_x = toxicity equivalency factor for congener x
 BEF_x = bioaccumulation equivalency factor for congener x

Table A

Minimum Levels, Toxicity Equivalency Factors,
 and Bioaccumulation Equivalency Factors

Dioxin or Furan Congener	Minimum Level (pg/L)	1998 Toxicity Equivalency Factor (TEF)	Bioaccumulation Equivalency Factor (BEF)
2,3,7,8-TCDD	10	1.0	1.0
1,2,3,7,8-PeCDD	50	1.0	0.9
1,2,3,4,7,8-HxCDD	50	0.1	0.3
1,2,3,6,7,8-HxCDD	50	0.1	0.1
1,2,3,7,8,9-HxCDD	50	0.1	0.1
1,2,3,4,6,7,8-HpCDD	50	0.01	0.05
OCDD	100	0.0001	0.01
2,3,7,8-TCDF	10	0.1	0.8
1,2,3,7,8-PeCDF	50	0.05	0.2
2,3,4,7,8-PeCDF	50	0.5	1.6
1,2,3,4,7,8-HxCDF	50	0.1	0.08
1,2,3,6,7,8-HxCDF	50	0.1	0.2
1,2,3,7,8,9-HxCDF	50	0.1	0.6
2,3,4,6,7,8-HxCDF	50	0.1	0.7
1,2,3,4,6,7,8-HpCDF	50	0.01	0.01
1,2,3,4,7,8,9-HpCDF	50	0.01	0.4
OCDF	100	0.0001	0.02

d. Data reporting for results not yet available

The Discharger shall make all reasonable efforts to obtain analytical data for required parameter sampling in a timely manner. Certain analyses require additional time to complete analytical processes and report results. For cases where required monitoring parameters require additional time to complete analytical processes and reports, and results are not available in time to be included in the SMR for the subject monitoring period, the Discharger shall describe such circumstances in the SMR and include the data for these parameters and relevant discussions of any observed exceedances in the next SMR due after the results are available.

e. Flow data

The Discharger shall provide flow data tabulation pursuant to Section IV.B.2.

f. Annual self monitoring report requirements

By the date specified in the MRP, the Discharger shall submit an annual report to the Regional Water Board covering the previous calendar year. The report shall contain the following:

- 1) Annual compliance summary table of treatment plant performance, including documentation of any blending events;
 - 2) Comprehensive discussion of treatment plant performance and compliance with the permit (This discussion shall include any corrective actions taken or planned, such as changes to facility equipment or operation practices that may be needed to achieve compliance, and any other actions taken or planned that are intended to improve performance and reliability of the Discharger's wastewater collection, treatment, or disposal practices.);
 - 3) Both tabular and graphical summaries of the monitoring data for the previous year if parameters are monitored at a frequency of monthly or greater;
 - 4) List of approved analyses, including the following:
 - (i) List of analyses for which the Discharger is certified;
 - (ii) List of analyses performed for the Discharger by a separate certified laboratory (copies of reports signed by the laboratory director of that laboratory shall not be submitted but be retained onsite); and
 - (iii) List of "waived" analyses, as approved;
 - 5) Plan view drawing or map showing the Discharger's facility, flow routing, and sampling and observation station locations;
 - 6) Results of annual facility inspection to verify that all elements of the SWPP Plan are accurate and up to date (only required if the Discharger does not route all storm water to the headworks of its wastewater treatment plant); and
 - 7) Results of facility report reviews (The Discharger shall regularly review, revise, and update, as necessary, the O&M Manual, the Contingency Plan, the Spill Prevention Plan, and Wastewater Facilities Status Report so that these documents remain useful and relevant to current practices. At a minimum, reviews shall be conducted annually. The Discharger shall include, in each Annual Report, a description or summary of review and evaluation procedures, recommended or planned actions, and an estimated time schedule for implementing these actions. The Discharger shall complete changes to these documents to ensure they are up-to-date.).
- g. Report submittal

The Discharger shall submit SMRs to:

California Regional Water Quality Control Board
San Francisco Bay Region
1515 Clay Street, Suite 1400
Oakland, CA 94612
Attn: NPDES Wastewater Division

h. Reporting data in electronic format

The Discharger has the option to submit all monitoring results in an electronic reporting format approved by the Executive Officer. If the Discharger chooses to submit SMRs electronically, the following shall apply:

- 1) *Reporting Method*: The Discharger shall submit SMRs electronically via a process approved by the Executive Officer (see, for example, the letter dated December 17, 1999, "Official Implementation of Electronic Reporting System [ERS]" and the progress report letter dated December 17, 2000).
- 2) *Monthly or Quarterly Reporting Requirements*: For each reporting period (monthly or quarterly as specified in the MRP), the Discharger shall submit an electronic SMR to the Regional Water Board in accordance with the provisions of Section V.C.1.a-e, except for requirements under Section V.C.1.c(1) where ERS does not have fields for dischargers to input certain information (e.g., sample time). However, until USEPA approves the electronic signature or other signature technologies, Dischargers that use ERS shall submit a hard copy of the original transmittal letter, an ERS printout of the data sheet, and a violation report (a receipt of the electronic transmittal shall be retained by the Discharger). This electronic SMR submittal suffices for the signed tabulations specified under Section V.C.1.c(1).
- 3) *Annual Reporting Requirements*: Dischargers who have submitted data using the ERS for at least one calendar year are exempt from submitting the portion of the annual report required under Section V.C.1.f(1) and (3).

D. Compliance Schedules – Not supplemented

E. Twenty-Four Hour Reporting – This section supplements V.E of Standard Provision (Attachment D)

1. Spill of Oil or Other Hazardous Material Reports

- a. Within 24 hours of becoming aware of a spill of oil or other hazardous material that is not contained onsite and completely cleaned up, the Discharger shall report by telephone to the Regional Water Board at (510) 622-2369.
- b. The Discharger shall also report such spills to the State Office of Emergency Services [telephone (800) 852-7550] only when the spills are in accordance with applicable reporting quantities for hazardous materials.
- c. The Discharger shall submit a written report to the Regional Water Board within five working days following telephone notification unless directed otherwise by Regional Water Board staff. A report submitted electronically is acceptable. The written report shall include the following:
 - 1) Date and time of spill, and duration if known;
 - 2) Location of spill (street address or description of location);

- 3) Nature of material spilled;
- 4) Quantity of material involved;
- 5) Receiving water body affected, if any;
- 6) Cause of spill;
- 7) Estimated size of affected area;
- 8) Observed impacts to receiving waters (e.g., oil sheen, fish kill, water discoloration);
- 9) Corrective actions taken to contain, minimize, or clean up the spill;
- 10) Future corrective actions planned to be taken to prevent recurrence, and schedule of implementation; and
- 11) Persons or agencies notified.

2. Unauthorized Discharges from Municipal Wastewater Treatment Plants¹

The following requirements apply to municipal wastewater treatment plants that experience an unauthorized discharge at their treatment facilities and are consistent with and supersede requirements imposed on the Discharger by the Executive Officer by letter of May 1, 2008, issued pursuant to California Water Code Section 13383.

a. Two (2)-Hour Notification

For any unauthorized discharges that result in a discharge to a drainage channel or a surface water, the Discharger shall, as soon as possible, but not later than two (2) hours after becoming aware of the discharge, notify the State Office of Emergency Services (telephone 800-852-7550), the local health officers or directors of environmental health with jurisdiction over the affected water bodies, and the Regional Water Board. The notification to the Regional Water Board shall be via the Regional Water Board's online reporting system at www.wbers.net, and shall include the following:

- 1) Incident description and cause;
- 2) Location of threatened or involved waterway(s) or storm drains;
- 3) Date and time the unauthorized discharge started;
- 4) Estimated quantity and duration of the unauthorized discharge (to the extent known), and the estimated amount recovered;

¹ California Code of Regulations, Title 23, Section 2250(b), defines an unauthorized discharge to be a discharge, not regulated by waste discharge requirements, of treated, partially treated, or untreated wastewater resulting from the intentional or unintentional diversion of wastewater from a collection, treatment or disposal system.

- 5) Level of treatment prior to discharge (e.g., raw wastewater, primary treated, undisinfected secondary treated, and so on); and
 - 6) Identity of the person reporting the unauthorized discharge.
- b. 24-hour Certification

Within 24 hours, the Discharger shall certify to the Regional Water Board, at www.wbers.net, that the State Office of Emergency Services and the local health officers or directors of environmental health with jurisdiction over the affected water bodies have been notified of the unauthorized discharge.

- c. 5-Day Written Report

Within five business days, the Discharger shall submit a written report, via the Regional Water Board's online reporting system at www.wbers.net, that includes, in addition to the information required above, the following:

- 1) Methods used to delineate the geographical extent of the unauthorized discharge within receiving waters;
 - 2) Efforts implemented to minimize public exposure to the unauthorized discharge;
 - 3) Visual observations of the impacts (if any) noted in the receiving waters (e.g., fish kill, discoloration of water) and the extent of sampling if conducted;
 - 4) Corrective measures taken to minimize the impact of the unauthorized discharge;
 - 5) Measures to be taken to minimize the chances of a similar unauthorized discharge occurring in the future;
 - 6) Summary of Spill Prevention Plan or O&M Manual modifications to be made, if necessary, to minimize the chances of future unauthorized discharges; and
 - 7) Quantity and duration of the unauthorized discharge, and the amount recovered.
- d. Communication Protocol

To clarify the multiple levels of notification, certification, and reporting, the current communication requirements for unauthorized discharges from municipal wastewater treatment plants are summarized in Table B that follows.

Table B

Summary of Communication Requirements for Unauthorized Discharges¹ from
 Municipal Wastewater Treatment Plants

Discharger is required to:	Agency Receiving Information	Time frame	Method for Contact
1. Notify	California Emergency Management Agency (Cal EMA)	As soon as possible, but not later than 2 hours after becoming aware of the unauthorized discharge.	Telephone – (800) 852-7550 (obtain a control number from Cal EMA)
	Local health department	As soon as possible, but not later than 2 hours after becoming aware of the unauthorized discharge.	Depends on local health department
	Regional Water Board	As soon as possible, but not later than 2 hours after becoming aware of the unauthorized discharge.	Electronic ² www.wbers.net
2. Certify	Regional Water Board	As soon as possible, but not later than 24 hours after becoming aware of the unauthorized discharge.	Electronic ³ www.wbers.net
3. Report	Regional Water Board	Within 5 business days of becoming aware of the unauthorized discharge.	Electronic ⁴ www.wbers.net

¹ California Code of Regulations, Title 23, Section 2250(b), defines an unauthorized discharge to be a discharge, not regulated by waste discharge requirements, of treated, partially treated, or untreated wastewater resulting from the intentional or unintentional diversion of wastewater from a collection, treatment or disposal system.

² In the event that the Discharger is unable to provide online notification within 2 hours of becoming aware of an unauthorized discharge, it shall phone the Regional Water Board’s spill hotline at (510) 622-2369 and convey the same information contained in the notification form. In addition, within 3 business days of becoming aware of the unauthorized discharge, the Discharger shall enter the notification information into the Regional Water Board’s online system in electronic format.

³ In most instances, the 2-hour notification will also satisfy 24-hour certification requirements. This is because the notification form includes fields for documenting that OES and the local health department have been contacted. In other words, if the Discharger is able to complete all the fields in the notification form within 2 hours, certification requirements are also satisfied. In the event that the Discharger is unable to provide online certification within 24 hours of becoming aware of an unauthorized discharge, it shall phone the Regional Water Board’s spill hotline at (510) 622-2369 and convey the same information contained in the certification form. In addition, within 3 business days of becoming aware of the unauthorized discharge, the Discharger shall enter the certification information into the Regional Water Board’s online system in electronic format.

⁴ If the Discharger cannot satisfy the 5-day reporting requirements via the Regional Water Board’s online reporting system, it shall submit a written report (preferably electronically in pdf) to the appropriate Regional Water Board case manager. In cases where the Discharger cannot satisfy the 5-day reporting requirements via the online reporting system, it must still complete the Regional Water Board’s online reporting requirements within 15 calendar days of becoming aware of the unauthorized discharge.

F. Planned Changes – Not supplemented

G. Anticipated Noncompliance – Not supplemented

H. Other Noncompliance – Not supplemented

I. Other Information – Not supplemented

VI. STANDARD PROVISIONS – ENFORCEMENT – Not Supplemented

VII. ADDITIONAL PROVISIONS – NOTIFICATION LEVELS – Not Supplemented

VIII. DEFINITIONS – This section is an addition to Standard Provisions (Attachment D)

More definitions can be found in Attachment A of this NPDES Permit.

1. Arithmetic Calculations

- a. Geometric mean is the antilog of the log mean or the back-transformed mean of the logarithmically transformed variables, which is equivalent to the multiplication of the antilogarithms. The geometric mean can be calculated with either of the following equations:

$$\text{Geometric Mean} = \text{Anti log} \left(\frac{1}{N} \sum_{i=1}^N \text{Log}(C_i) \right)$$

or

$$\text{Geometric Mean} = (C_1 * C_2 * \dots * C_N)^{1/N}$$

Where “N” is the number of data points for the period analyzed and “C” is the concentration for each of the “N” data points.

- b. Mass emission rate is obtained from the following calculation for any calendar day:

$$\text{Mass emission rate (lb/day)} = \frac{8.345}{N} \sum_{i=1}^N Q_i C_i$$

$$\text{Mass emission rate (kg/day)} = \frac{3.785}{N} \sum_{i=1}^N Q_i C_i$$

In which “N” is the number of samples analyzed in any calendar day and “Q_i” and “C_i” are the flow rate (MGD) and the constituent concentration (mg/L) associated with each of the “N” grab samples that may be taken in any calendar day. If a composite sample is taken, “C_i” is the concentration measured in the composite sample and “Q_i” is the average flow rate occurring during the period over which the samples are composited. The daily concentration of a constituent measured over any calendar day shall be determined from the flow-weighted average of the same constituent in the combined waste streams as follows:

$$C_d = \text{Average daily concentration} = \frac{1}{Q_t} \sum_{i=1}^N Q_i C_i$$

In which “N” is the number of component waste streams and “Q” and “C” are the flow rate (MGD) and the constituent concentration (mg/L) associated with each of the “N” waste streams. “Q_t” is the total flow rate of the combined waste streams.

- c. Maximum allowable mass emission rate, whether for a 24-hour, weekly 7-day, monthly 30-day, or 6-month period, is a limitation expressed as a daily rate determined with the formulas in the paragraph above, using the effluent concentration limit specified in the permit for the period and the specified allowable flow.
- d. POTW removal efficiency is the ratio of pollutants removed by the treatment facilities to pollutants entering the treatment facilities (expressed as a percentage). The Discharger shall determine removal efficiencies using monthly averages (by calendar month unless otherwise specified) of pollutant concentration of influent and effluent samples collected at about the same time and using the following equation (or its equivalent):

$$\text{Removal Efficiency (\%)} = 100 \times [1 - (\text{Effluent Concentration} / \text{Influent Concentration})]$$

- 2. Biosolids means the solids, semi-liquid suspensions of solids, residues, screenings, grit, scum, and precipitates separated from or created in wastewater by the unit processes of a treatment system. It also includes, but is not limited to, all supernatant, filtrate, centrate, decantate, and thickener overflow and underflow in the solids handling parts of the wastewater treatment system.
- 3. Blending is the practice of recombining wastewater that has been biologically treated with wastewater that has bypassed around biological treatment units.
- 4. Bottom sediment sample is (1) a separate grab sample taken at each sampling station for the determination of selected physical-chemical parameters, or (2) four grab samples collected from different locations in the immediate vicinity of a sampling station while the boat is anchored and analyzed separately for macroinvertebrates.
- 5. Composite sample is a sample composed of individual grab samples collected manually or by an automatic sampling device on the basis of time or flow as specified in the MRP. For flow-based composites, the proportion of each grab sample included in the composite sample shall be within plus or minus five percent (+/-5%) of the representative flow rate of the waste stream being measured at the time of grab sample collection. Alternatively, equal volume grab samples may be individually analyzed with the flow-weighted average calculated by averaging flow-weighted ratios of each grab sample analytical result. Grab samples comprising time-based composite samples shall be collected at intervals not greater than those specified in the MRP. The quantity of each grab sample comprising a time-based composite sample shall be a set of flow proportional volumes as specified in the MRP. If a particular time-based or flow-based composite sampling protocol is not specified in the MRP, the Discharger shall determine and implement the most representative sampling protocol for the given parameter subject to Executive Officer approval.
- 6. Depth-integrated sample is defined as a water or waste sample collected by allowing a sampling device to fill during a vertical traverse in the waste or receiving water body being sampled. The

Discharger shall collect depth-integrated samples in such a manner that the collected sample will be representative of the waste or water body at that sampling point.

7. Flow sample is an accurate measurement of the average daily flow volume using a properly calibrated and maintained flow measuring device.
8. Grab sample is an individual sample collected in a short period of time not exceeding 15 minutes. Grab samples represent only the condition that exists at the time the wastewater is collected.
9. Initial dilution is the process that results in the rapid and irreversible turbulent mixing of wastewater with receiving water around the point of discharge.
10. Overflow is the intentional or unintentional spilling or forcing out of untreated or partially treated wastes from a transport system (e.g., through manholes, at pump stations, and at collection points) upstream from the treatment plant headworks or from any part of a treatment plant facility.
11. Priority pollutants are those constituents referred to in 40 CFR Part 122 as promulgated in the Federal Register, Vol. 65, No. 97, Thursday, May 18, 2000, also known as the California Toxics Rule, the presence or discharge of which could reasonably be expected to interfere with maintaining designated uses.
12. Storm water means storm water runoff, snow melt runoff, and surface runoff and drainage. It excludes infiltration and runoff from agricultural land.
13. Toxic pollutant means any pollutant listed as toxic under federal Clean Water Act section 307(a)(1) or under 40 CFR 401.15.
14. Untreated waste is raw wastewater.
15. Waste, waste discharge, discharge of waste, and discharge are used interchangeably in the permit. The requirements of the permit apply to the entire volume of water, and the material therein, that is disposed of to surface and ground waters of the State of California.

Table C

List of Monitoring Parameters and Analytical Methods

CTR No.	Pollutant/Parameter	Analytical Method ¹	Minimum Levels ² (µg/l)											
			GC	GCMS	LC	Color	FAA	GFAA	ICP	ICP MS	SPGFAA	HYD RIDE	CVAA	DCP
1.	Antimony	204.2					10	5	50	0.5	5	0.5		1000
2.	Arsenic	206.3				20		2	10	2	2	1		1000
3.	Beryllium						20	0.5	2	0.5	1			1000
4.	Cadmium	200 or 213					10	0.5	10	0.25	0.5			1000
5a.	Chromium (III)	SM 3500												
5b.	Chromium (VI)	SM 3500				10	5							1000
	Chromium (total) ³	SM 3500					50	2	10	0.5	1			1000
6.	Copper	200.9					25	5	10	0.5	2			1000
7.	Lead	200.9					20	5	5	0.5	2			10,000
8.	Mercury	1631 (note) ⁴												
9.	Nickel	249.2					50	5	20	1	5			1000
10.	Selenium	200.8 or SM 3114B or C						5	10	2	5	1		1000
11.	Silver	272.2					10	1	10	0.25	2			1000
12.	Thallium	279.2					10	2	10	1	5			1000
13.	Zinc	200 or 289					20		20	1	10			
14.	Cyanide	SM 4500 CN ⁻ C or I				5								
15.	Asbestos (only required for dischargers to MUN waters) ⁵	0100.2 ⁶												
16.	2,3,7,8-TCDD and 17 congeners (Dioxin)	1613												
17.	Acrolein	603	2.0	5										
18.	Acrylonitrile	603	2.0	2										
19.	Benzene	602	0.5	2										
33.	Ethylbenzene	602	0.5	2										
39.	Toluene	602	0.5	2										
20.	Bromoform	601	0.5	2										
21.	Carbon Tetrachloride	601	0.5	2										
22.	Chlorobenzene	601	0.5	2										
23.	Chlorodibromomethane	601	0.5	2										
24.	Chloroethane	601	0.5	2										

¹ The suggested method is the USEPA Method unless otherwise specified (SM = Standard Methods). The Discharger may use another USEPA-approved or recognized method if that method has a level of quantification below the applicable water quality objective. Where no method is suggested, the Discharger has the discretion to use any standard method.

² Minimum levels are from the *State Implementation Policy*. They are the concentration of the lowest calibration standard for that technique based on a survey of contract laboratories. Laboratory techniques are defined as follows: GC = Gas Chromatography; GCMS = Gas Chromatography/Mass Spectrometry; LC = High Pressure Liquid Chromatography; Color = Colorimetric; FAA = Flame Atomic Absorption; GFAA = Graphite Furnace Atomic Absorption; ICP = Inductively Coupled Plasma; ICPMS = Inductively Coupled Plasma/Mass Spectrometry; SPGFAA = Stabilized Platform Graphite Furnace Atomic Absorption (i.e., USEPA 200.9); Hydride = Gaseous Hydride Atomic Absorption; CVAA = Cold Vapor Atomic Absorption; DCP = Direct Current Plasma.

³ Analysis for total chromium may be substituted for analysis of chromium (III) and chromium (VI) if the concentration measured is below the lowest hexavalent chromium criterion (11 µg/l).

⁴ The Discharger shall use ultra-clean sampling (USEPA Method 1669) and ultra-clean analytical methods (USEPA Method 1631) for mercury monitoring. The minimum level for mercury is 2 ng/l (or 0.002 µg/l).

⁵ MUN = Municipal and Domestic Supply. This designation, if applicable, is in the Findings of the permit.

⁶ *Determination of Asbestos Structures over 10 [micrometers] in Length in Drinking Water Using MCE Filters*, USEPA 600/R-94-134, June 1994.

CTR No.	Pollutant/Parameter	Analytical Method ¹	Minimum Levels ² (µg/l)											
			GC	GCMS	LC	Color	FAA	GFAA	ICP	ICP MS	SPGFAA	HYD RIDE	CVAA	DCP
25.	2-Chloroethylvinyl Ether	601	1	1										
26.	Chloroform	601	0.5	2										
75.	1,2-Dichlorobenzene	601	0.5	2										
76.	1,3-Dichlorobenzene	601	0.5	2										
77.	1,4-Dichlorobenzene	601	0.5	2										
27.	Dichlorobromomethane	601	0.5	2										
28.	1,1-Dichloroethane	601	0.5	1										
29.	1,2-Dichloroethane	601	0.5	2										
30.	1,1-Dichloroethylene or 1,1-Dichloroethene	601	0.5	2										
31.	1,2-Dichloropropane	601	0.5	1										
32.	1,3-Dichloropropylene or 1,3-Dichloropropene	601	0.5	2										
34.	Methyl Bromide or Bromomethane	601	1.0	2										
35.	Methyl Chloride or Chloromethane	601	0.5	2										
36.	Methylene Chloride or Dichloromethane	601	0.5	2										
37.	1,1,2,2-Tetrachloroethane	601	0.5	1										
38.	Tetrachloroethylene	601	0.5	2										
40.	1,2-Trans-Dichloroethylene	601	0.5	1										
41.	1,1,1-Trichloroethane	601	0.5	2										
42.	1,1,2-Trichloroethane	601	0.5	2										
43.	Trichloroethene	601	0.5	2										
44.	Vinyl Chloride	601	0.5	2										
45.	2-Chlorophenol	604	2	5										
46.	2,4-Dichlorophenol	604	1	5										
47.	2,4-Dimethylphenol	604	1	2										
48.	2-Methyl-4,6-Dinitrophenol or Dinitro-2-methylphenol	604	10	5										
49.	2,4-Dinitrophenol	604	5	5										
50.	2-Nitrophenol	604		10										
51.	4-Nitrophenol	604	5	10										
52.	3-Methyl-4-Chlorophenol	604	5	1										
53.	Pentachlorophenol	604	1	5										
54.	Phenol	604	1	1		50								
55.	2,4,6-Trichlorophenol	604	10	10										
56.	Acenaphthene	610 HPLC	1	1	0.5									
57.	Acenaphthylene	610 HPLC		10	0.2									
58.	Anthracene	610 HPLC		10	2									
60.	Benzo(a)Anthracene or 1,2 Benzanthracene	610 HPLC	10	5										
61.	Benzo(a)Pyrene	610 HPLC		10	2									
62.	Benzo(b)Fluoranthene or 3,4 Benzofluoranthene	610 HPLC		10	10									
63.	Benzo(ghi)Perylene	610 HPLC		5	0.1									
64.	Benzo(k)Fluoranthene	610 HPLC		10	2									
74.	Dibenzo(a,h)Anthracene	610 HPLC		10	0.1									
86.	Fluoranthene	610 HPLC	10	1	0.05									
87.	Fluorene	610 HPLC		10	0.1									
92.	Indeno(1,2,3-cd) Pyrene	610 HPLC		10	0.05									
100.	Pyrene	610 HPLC		10	0.05									
68.	Bis(2-Ethylhexyl)Phthalate	606 or 625	10	5										

CTR No.	Pollutant/Parameter	Analytical Method ¹	Minimum Levels ² (µg/l)											
			GC	GCMS	LC	Color	FAA	GFAA	ICP	ICP MS	SPGFAA	HYD RIDE	CVAA	DCP
70.	Butylbenzyl Phthalate	606 or 625	10	10										
79.	Diethyl Phthalate	606 or 625	10	2										
80.	Dimethyl Phthalate	606 or 625	10	2										
81.	Di-n-Butyl Phthalate	606 or 625		10										
84.	Di-n-Octyl Phthalate	606 or 625		10										
59.	Benzidine	625		5										
65.	Bis(2-Chloroethoxy)Methane	625		5										
66.	Bis(2-Chloroethyl)Ether	625	10	1										
67.	Bis(2-Chloroisopropyl)Ether	625	10	2										
69.	4-Bromophenyl Phenyl Ether	625	10	5										
71.	2-Chloronaphthalene	625		10										
72.	4-Chlorophenyl Phenyl Ether	625		5										
73.	Chrysene	625		10	5									
78.	3,3'-Dichlorobenzidine	625		5										
82.	2,4-Dinitrotoluene	625	10	5										
83.	2,6-Dinitrotoluene	625		5										
85.	1,2-Diphenylhydrazine (note) ⁷	625		1										
88.	Hexachlorobenzene	625	5	1										
89.	Hexachlorobutadiene	625	5	1										
90.	Hexachlorocyclopentadiene	625	5	5										
91.	Hexachloroethane	625	5	1										
93.	Isophorone	625	10	1										
94.	Naphthalene	625	10	1	0.2									
95.	Nitrobenzene	625	10	1										
96.	N-Nitrosodimethylamine	625	10	5										
97.	N-Nitrosodi-n-Propylamine	625	10	5										
98.	N-Nitrosodiphenylamine	625	10	1										
99.	Phenanthrene	625		5	0.05									
101.	1,2,4-Trichlorobenzene	625	1	5										
102.	Aldrin	608	0.005											
103.	α-BHC	608	0.01											
104.	β-BHC	608	0.005											
105.	γ-BHC (Lindane)	608	0.02											
106.	δ-BHC	608	0.005											
107.	Chlordane	608	0.1											
108.	4,4'-DDT	608	0.01											
109.	4,4'-DDE	608	0.05											
110.	4,4'-DDD	608	0.05											
111.	Dieldrin	608	0.01											
112.	Endosulfan (alpha)	608	0.02											
113.	Endosulfan (beta)	608	0.01											
114.	Endosulfan Sulfate	608	0.05											
115.	Endrin	608	0.01											
116.	Endrin Aldehyde	608	0.01											
117.	Heptachlor	608	0.01											
118.	Heptachlor Epoxide	608	0.01											
119.	PCBs: Aroclors 1016, 1221,	608	0.5											

⁷ Measurement for 1,2-Diphenylhydrazine may use azobenzene as a screen: if azobenzene is measured at >1 ug/l, then the Discharger shall analyze for 1,2-Diphenylhydrazine.

CTR No.	Pollutant/Parameter	Analytical Method ¹	Minimum Levels ² (µg/l)											
			GC	GCMS	LC	Color	FAA	GFAA	ICP	ICP MS	SPGFAA	HYD RIDE	CVAA	DCP
125	1232, 1242, 1248, 1254, 1260													
126.	Toxaphene	608	0.5											