

STATE OF CALIFORNIA  
CALIFORNIA REGIONAL WATER QUALITY CONTROL BOARD  
SAN FRANCISCO BAY REGION

STAFF SUMMARY REPORT (Robert Schlipf)  
MEETING DATE: July 8, 2015

ITEM: 5A

SUBJECT: **Tesoro Refining and Marketing Company, Tesoro Martinez Refinery, Martinez, Contra Costa County - Reissuance of NPDES Permit**

CHRONOLOGY: June 2010 –NPDES permit reissued

DISCUSSION: The Tentative Order (Appendix A) would reissue the NPDES permit that covers discharges from Tesoro's wastewater treatment plant and stormwater outfalls. Tesoro operates a petroleum refinery that processes about 144,000 barrels per day of crude oil. This production results in a discharge of 4.4-million gallons per day of treated wastewater to Suisun Bay via a deepwater diffuser that is about 1,200 feet offshore. Tesoro also discharges stormwater associated with industrial activities to Walnut Creek and Hastings Slough.

This reissuance would update technology- and water quality-based effluent limits in the permit based on current data from treatment plant operations, ambient data from the Bay, and applicable State and federal regulations. There is a new requirement in the Tentative Order for Tesoro to install underground detention basins at two locations to improve stormwater quality. This is the most significant change to the existing permit.

We received no comments on the Tentative Order during the public comment period. While we have made minor editorial and formatting changes, we have not revised the Tentative Order and expect it to remain uncontested.

RECOMMEN-  
DATION: Adoption of the Tentative Order

FILE: CW-228968

Appendix A: Tentative Order

# **APPENDIX A**

**San Francisco Bay Regional Water Quality Control Board**

**TENTATIVE ORDER No. R2-2015-00XX**  
**NPDES NO. CA0004961**

The following discharger is subject to waste discharge requirements (WDRs) set forth in this Order.

**Table 1. Discharger Information**

<b>Discharger</b>	<b>Tesoro Refining and Marketing Company LLC</b>
<b>Facility Name</b>	Tesoro Martinez Refinery
<b>Facility Address</b>	150 Solano Way Martinez, CA 94553 Contra Costa County
<b>CIWQS Place Number</b>	228968

**Table 2. Discharge Locations**

<b>Discharge Point</b>	<b>Effluent Description</b>	<b>Discharge Point Latitude</b>	<b>Discharge Point Longitude</b>	<b>Receiving Water</b>
001	Treated refinery process wastewater and stormwater	38.0483	-122.08944	Suisun Bay
003	Stormwater from about 76 acres in the southwestern portion of the Tract 4 tank farm.	38.0122	-122.0652	Walnut Creek
004	Stormwater from about 198 acres, including the southeast portion of the Tract 4 tank farm and all of the Tract 6 tank farm and offsite facilities.	38.0225	-122.0583	Hastings Slough
005-T2NW	Stormwater from small areas near a stairway leading down to a non-operating saltwater pump station on the creek side of the slope.	38.0302	-122.0753	Walnut Creek
005-T2S-A	Stormwater from small areas near the channel drain along the north side of a fence at a used equipment reclamation area before Gate 15 south of the Foster Wheeler area.	38.0191	-122.0669	Walnut Creek
005-T2S-B	Stormwater from small areas near the fence line immediately north of the railroad tracks. This area is at the extreme south end of Tract 2.	38.0193	-122.0674	Walnut Creek
005-T2S-C	Stormwater from small areas across the road west of the Foster Wheeler yard (three tall gray tanks) where runoff from the asphalt perimeter drainage channels run under the road towards the creek.	38.0202	-122.0682	Walnut Creek

Discharge Point	Effluent Description	Discharge Point Latitude	Discharge Point Longitude	Receiving Water
005-T2SW	Stormwater from small areas near the "D" Street firehouse, against the fence. This area includes paved areas around the auto shop and the western side of the Purchasing and Storehouse.	38.0223	-122.0693	Walnut Creek
005-T4NW	Stormwater from small areas at the easternmost culvert that conveys runoff from this area under the road to the west.	38.0179	-122.0675	Walnut Creek
005-T4SW	Stormwater from small areas near the outlet of the pipe that drains the impoundment. The pipe has a locked valve on it and is required to be sampled when there is a discharge from the impoundment.	38.0042	-122.0583	Walnut Creek
006	Waste Management Unit (WMU) 5 Cap Runoff	38.0274	-122.0567	Walnut Creek

**Table 3. Administrative Information**

This Order was adopted on:	<b>DATE</b>
This Order shall become effective on:	September 1, 2015
This Order shall expire on:	August 31, 2020
CIWQS Regulatory Measure Number	<b>TBD</b>
The Discharger shall file a Report of Waste Discharge as an application for reissuance of WDRs in accordance with California Code of Regulations, title 23, and an application for reissuance of a National Pollutant Discharge Elimination System (NPDES) permit no later than:	December 5, 2019
The U.S. Environmental Protection Agency (U.S. EPA) and the California Regional Water Quality Control Board, San Francisco Bay Region, have classified this discharge as follows:	Major

I, Bruce H. Wolfe, Executive Officer, do hereby certify that this Order with all attachments is a full, true, and correct copy of the Order adopted by the California Regional Water Quality Control Board, San Francisco Bay Region, on the date indicated above.

\_\_\_\_\_  
 Bruce H. Wolfe, Executive Officer

## Contents

I.	Facility Information .....	4
II.	Findings.....	4
III.	Discharge Prohibitions.....	4
IV.	Effluent Limitations and Discharge Specifications .....	5
V.	Receiving Water Limitations .....	9
VI.	Provisions.....	11
	A.... Standard Provisions .....	11
	B.... Monitoring and Reporting .....	11
	C.... Special Provisions .....	11
	1. Reopener Provisions .....	11
	2. Effluent Characterization Study and Report .....	12
	3. Pollutant Minimization Program .....	13
	4. Other Special Provisions .....	15

## Tables

Table 1.	Discharger Information.....	1
Table 2.	Discharge Locations .....	1
Table 3.	Administrative Information .....	2
Table 4.	Production-Based Mass Emission & Technology-Based Concentration Limits .....	5
Table 5.	Stormwater Runoff Allocation.....	5
Table 6.	Ballast Water Allocation.....	6
Table 7.	Effluent Limitations for Toxic Substances <sup>1</sup> .....	6
Table 8.	Selenium Mass Emission Limitation <sup>1</sup> .....	6
Table 9.	Effluent Limitations for Stormwater Outfalls.....	9
Table 10.	Supplemental Effluent Limitations for Stormwater Outfalls.....	9
Table 11.	Copper Action Plan.....	15
Table 12.	Cyanide Action Plan .....	15

## Attachments

Attachment A –	Definitions .....	A-1
Attachment B –	Facility Map.....	B-1
Attachment C –	Process Flow Diagram.....	C-1
Attachment D –	Federal Standard Provisions.....	D-1
Attachment E –	Monitoring and Reporting Program (MRP).....	E-1
Attachment F –	Fact Sheet.....	F-1
Attachment G –	Regional Standard Provisions and Monitoring and Reporting Requirements .....	G-1

## I. FACILITY INFORMATION

Information describing the Tesoro Martinez Refinery (the Facility) is summarized in Table 1 and in Fact Sheet (Attachment F) sections I and II.

## II. FINDINGS

The California Regional Water Quality Control Board, San Francisco Bay Region (Regional Water Board), finds:

- A. Legal Authorities.** This Order serves as WDRs pursuant to California Water Code article 4, chapter 4, division 7 (commencing with § 13260). This Order is also issued pursuant to federal Clean Water Act (CWA) section 402 and implementing regulations adopted by U.S. EPA and Water Code chapter 5.5, division 7 (commencing with § 13370). It shall serve as an NPDES permit for point source discharges from the Facility to surface waters.
- B. Background and Rationale for Requirements.** The Regional Water Board developed the requirements in this Order based on information the Discharger submitted as part of its application, information obtained through monitoring and reporting programs, and other available information. The Fact Sheet (Attachment F) contains background information and rationale for the requirements in this Order and is hereby incorporated into and constitutes findings for this Order. Attachments A through E and G are also incorporated into this Order.
- C. Provisions and Requirements Implementing State Law.** No provisions and requirements in this Order are included to implement State law only.
- D. Notification of Interested Parties.** The Regional Water Board notified the Discharger and interested agencies and persons of its intent to prescribe these WDRs and provided an opportunity to submit written comments and recommendations. The Fact Sheet provides details regarding the notification.
- E. Consideration of Public Comment.** The Regional Water Board, in a public meeting, heard and considered all comments pertaining to the discharge. The Fact Sheet provides details regarding the public hearing.

**THEREFORE, IT IS HEREBY ORDERED** that Order No. R2-2010-0084 is rescinded upon the effective date of this Order except for enforcement purposes, and, in order to meet the provisions of Water Code division 7 (commencing with § 13000) and regulations adopted thereunder, and the provisions of the CWA and regulations and guidelines adopted thereunder, the Discharger shall comply with the requirements in this Order. This action in no way prevents the Regional Water Board from taking enforcement action for past violations of the previous order.

## III. DISCHARGE PROHIBITIONS

- A.** Discharge of wastewater at a location or in a manner different from that described in this Order is prohibited.
- B.** Discharge at Discharge Point No. 001 is prohibited when treated wastewater does not receive an initial dilution of at least 15:1 (as modeled). Compliance shall be achieved by proper operation and maintenance of the discharge outfall to ensure that it (or its replacement, in whole or part) is in good

working order and is consistent with or can achieve better mixing than that described in Fact Sheet section IV.C.4.a. The Discharger shall address measures taken to ensure this in its application for permit reissuance.

- C. The bypass of untreated or partially-treated wastewater to waters of the United States is prohibited, except as provided for in Attachment D section I.G of this Order.

**IV. EFFLUENT LIMITATIONS AND DISCHARGE SPECIFICATIONS**

**A. Effluent Limitations – Discharge Point 001**

**i. Technology-Based Effluent Limitations**

- a. The Discharger shall maintain compliance with the following effluent limitations at Discharge Point 001, with compliance measured at Monitoring Location EFF-001 as described in the attached MRP (Attachment E):

**Table 4. Production-Based Mass Emission & Technology-Based Concentration Limits**

Parameter	Units	Effluent Limitations	
		Average Monthly	Maximum Daily
BOD <sub>5</sub>	lbs/day	2.0 x 10 <sup>3</sup>	3,600
COD	lbs/day	14,000	27,000
TSS	lbs/day	1,600	2,500
Oil & Grease	lbs/day	590	1,100
	mg/L	8	15
Phenolic Compounds	lbs/day	13	27
Ammonia (N)	lbs/day	1,100	2,400
Sulfide	lbs/day	11	24
Total Chromium	lbs/day	15	43
Hexavalent Chromium	lbs/day	1.2	2.7
pH	s.u.	6.0 - 9.0 at all times <sup>[1]</sup>	

<sup>[1]</sup> If the Discharger monitors pH continuously, pursuant to 40 C.F.R. section 401.17 the Discharger shall be in compliance with this pH limitation provided that both of the following conditions are satisfied: (i) the total time during which the pH is outside the required range shall not exceed 7 hours and 26 minutes in any calendar month; and (ii) no individual excursion from the required pH range shall exceed 60 minutes.

- b. In addition to the monthly average and daily maximum pollutant weight allowances shown in A.1, allocations for pollutants attributable to stormwater runoff and ballast water discharged as a part of Discharge Point 001 are permitted in accordance with the following schedules:

**Table 5. Stormwater Runoff Allocation**

Pollutant	Units	Monthly Average	Daily Maximum
BOD <sub>5</sub>	mg/L	26	48
TSS	mg/L	21	33
COD	mg/L	180	360
Oil and Grease	mg/L	8.0	15
Phenolic Compounds	mg/L	0.17	0.35
Total Chromium	mg/L	0.21	0.60
Hexavalent Chromium	mg/L	0.028	0.062

**Table 6. Ballast Water Allocation**

Pollutant	Units	Monthly Average	Daily Maximum
BOD <sub>5</sub>	mg/L	26	48
TSS	mg/L	21	33
COD	mg/L	240	470
Oil and Grease	mg/L	8.0	15

**ii. Effluent Limitations for Toxic Substances**

The Discharger shall maintain compliance with the following effluent limitations at Discharge Point 001, with compliance measured at Monitoring Location EFF-001:

**Table 7. Effluent Limitations for Toxic Substances<sup>1</sup>**

Parameter	Units	Final Effluent Limitations	
		Average Monthly	Maximum Daily
Copper	µg/L	37	120
Selenium	µg/L	39	50
Lead	µg/L	3.7	7.8
Cyanide	µg/L	21	40
Dioxin-TEQ	µg/L	1.4 x 10 <sup>-8</sup>	2.8 x 10 <sup>-8</sup>
Ammonia (N)	mg/L	26	67

- <sup>1</sup>
- a. Limitations apply to the average concentration of all samples collected during the averaging period (daily = 24-hour period; monthly = calendar month).
  - b. All metals limitations are expressed as total recoverable metal.

**iii. Bacteria**

- a. **Total Coliform.** At monitoring locations EFF-001-D1 and EFF-001-D2, the median of five consecutive samples shall not have total coliform organisms exceeding 240 MPN/100 mL. Any single sample shall not exceed 10,000 MPN/100 mL.
- b. **Enterococcus.** At monitoring locations EFF-001-D1 and EFF-001-D2, the geometric mean enterococcus bacteria concentration of all samples in a calendar month shall not exceed 364 colonies per 100 milliliters (CFU/100 mL).

**iv. Mass Emission Limitation for Selenium**

Until implementation of a TMDL is in effect for selenium, the Discharger shall not increase mass loading of selenium to Suisun Bay through Discharge Point 001 by complying with the following mass emission limitation:

**Table 8. Selenium Mass Emission Limitation<sup>1</sup>**

Pollutant	Units	Effluent Limitation
Selenium	Annual Average, kg/day	0.45

<sup>1</sup> The selenium mass emission limit is expressed as a running annual average. The running annual average is the arithmetic average of the current day's mass load and the mass loads for each of the previous 364 days, as shown in the following example:

$$\text{Annual Mass emission rate (kg/day)} = \frac{3.785}{N} \sum_{i=1}^N Q_i C_i$$



where:

N = number of samples analyzed in any calendar year

Q<sub>i</sub> = flow rate (MGD) associated with the N<sup>th</sup> sample

C<sub>i</sub> = selenium concentration (mg/L) associated with the N<sup>th</sup> sample

**v. Acute Toxicity**

Discharges at Discharge Point No. 001 shall comply with the following limitations, with compliance measured at Monitoring Location EFF-001 as described in the MRP:

- a. An 11-sample median value of not less than 90 percent survival; and
- b. An 11-sample 90th percentile value of not less than 70 percent survival.

These acute toxicity limitations are defined as follows:

- **11-sample median.** A bioassay test showing survival of less than 90 percent represents a violation of this effluent limit if five or more of the past ten or fewer bioassay tests also show less than 90 percent survival.
- **11-sample 90<sup>th</sup> percentile.** A bioassay test showing survival of less than 70 percent represents a violation of this effluent limit if one or more of the past ten or fewer bioassay tests also show less than 70 percent survival.

Bioassays shall be performed using the most up-to-date U.S. EPA protocols and species as specified in the MRP. If these protocols prove unworkable, the Executive Officer and the Environmental Laboratory Accreditation Program may grant exceptions in writing upon the Discharger's request with justification.

If the Discharger can demonstrate to the satisfaction of the Executive Officer that toxicity exceeding the levels cited above is caused by ammonia and that the ammonia in the discharge complies with the ammonia effluent limitations, then such toxicity does not constitute a violation of this effluent limitation.

**vi. Chronic Toxicity**

The survival of bioassay test organisms in the discharge at Discharge Point No. 001 shall be a single sample value equal to or less than 10 TUc. Compliance shall be measured at Monitoring Location EFF-001 with testing conducted in compliance with MRP section V.B (Attachment E).

**vii. Effluent Limitation Adjustment for Recycled Water Use**

If the Discharger uses recycled water, adjustments for influent concentrations for constituents in this Order with mass- or concentration-based effluent limitations shall be granted in the discharge according to the following procedure, provided the Discharger satisfies Provision VI.C.4.e:

- a. The Discharger shall sample and analyze for constituents for which effluent limitation adjustment is sought at least as frequently as is required in the attached Monitoring and

Reporting Program (MRP) for that constituent. Influent sampling shall occur at influent sampling station INF-001 defined in the MRP.

- b. The Discharger shall determine the time interval between introduction of a given constituent of concern in the influent recycled water and the first appearance of the constituent in the final effluent. This determination is subject to approval by the Executive Officer and must precede any calculation of effluent limitation adjustment for the constituent.
- c. Adjustment for ammonia, copper, lead, selenium, and cyanide will be given as follows:

Concentration Adjustment

Influent concentration multiplied by total influent reclaimed water flow volume for that monitoring interval will yield an influent mass for each constituent, which is valid for that monitoring interval. After the appropriate time lag interval described in IV.A.7.b above, this influent mass of the constituent is then divided by the total effluent flow volume for that monitoring period to give a concentration adjustment for the effluent that will apply for the monitoring interval. The monitoring interval is the time between sampling days. For example, weekly sampling yields a one week monitoring interval. A schematic example follows:

*ex.* Constituent B is monitored weekly. The lag time is Y days.

Step 1: (Influent concentration of recycled water B - influent concentration of potable water B) x (Total Influent Volume of Reclaimed Water for one week) = (Influent mass of B)

Step 2: (Influent mass of B) / (Discharge Point No. 001 discharge volume for one week, Y days after influent week) = (Concentration adjustment to be subtracted from concentration of constituent in the effluent, valid for that one week period)

The potable water concentrations used in Step 1 can be an average of samples (minimum of one sample) collected over the last year.

- d. Adjustment for selenium and technology-based limits listed in Table 4 will be given as follows:

Mass Adjustment

Influent concentration multiplied by total influent reclaimed water volume for that monitoring interval will yield an influent mass for each constituent, which is valid for that monitoring interval. After the appropriate time lag interval described in IV.A.7.b above, this influent mass of the constituent is then divided by the number of days in that monitoring period to give a mass adjustment for the effluent that will apply for the monitoring interval. The monitoring interval is the time between sampling days. For example, weekly sampling yields a one week monitoring interval. A schematic example follows:

*ex.* Constituent B is monitored weekly. The lag time is Y days.

Step 1: (Influent concentration of reclaimed water B – influent concentration of potable water B) x (Total Influent Volume of Reclaimed Water for one week) = (Influent mass of B)

Step 2: (Influent mass of B) / (The Number of Days in that monitoring interval) = (Mass adjustment to be subtracted from mass of constituent in the effluent, valid for that one week period)

**B. Stormwater Effluent Limitations – Discharge Points 003 – 006**

- i. Stormwater discharged at Discharge Points 003 – 006 shall not exceed the effluent limitations in Table 9, below:

**Table 9. Effluent Limitations for Stormwater Outfalls**

Parameter	Units	Effluent Limitations	
		Average Monthly	Maximum Daily
TOC	mg/L	----	110
Oil & Grease	mg/L	----	15
pH	s.u.	6.5 – 8.5 at all times	
Visible Oil	---	None observed	
Visible Color	---	None observed	

- ii. If there is an exceedance of either limitation for TOC or Oil and Grease expressed in Table 9, above, the effluent limitations in Table 10, below, shall become effective for the discharge point where the exceedance occurred and remain in effect until such time the Discharger can demonstrate to the satisfaction of the Executive Officer that the stormwater is not contaminated.

**Table 10. Supplemental Effluent Limitations for Stormwater Outfalls**

Pollutant	Units	Daily Maximum	30-Day Average <sup>[1]</sup>
BOD <sub>5</sub>	mg/L	48	26
TSS	mg/L	33	21
COD	mg/L	360	180
Oil and Grease	mg/L	15	8.0
Phenolic Compounds	mg/L	0.35	0.17
Total Chromium	mg/L	0.60	0.21
Hexavalent Chromium	mg/L	0.062	0.028

<sup>[1]</sup> Compliance with the 30-day average limitation shall be determined as a rolling 30-day average. The rolling 30-day average shall be calculated as the arithmetic average of the concentrations detected over the current day and previous 29 days. This limitation shall not apply unless there is sufficient runoff for sampling on at least three out of 30 consecutive days.

**V. RECEIVING WATER LIMITATIONS**

- A. Receiving water limitations are based on water quality objectives (WQOs) contained in the Basin Plan and are a required part of this Order. The discharges shall not cause the following in Central San Francisco Bay:
  1. Floating material, including solids, liquids, foams, and scum, in concentrations that cause nuisance or adversely affect beneficial uses;
  2. Alteration of suspended sediment in such a manner as to cause nuisance or adversely affect beneficial uses, or detrimental increase in the concentrations of toxic pollutants in sediments or aquatic life;

3. Suspended material in concentrations that cause nuisance or adversely affect beneficial uses;
  4. Bottom deposits or aquatic growths to the extent that such deposits or growths cause nuisance or adversely affect beneficial uses;
  5. Alteration of temperature beyond present natural background levels;
  6. Changes in turbidity that cause nuisance or adversely affect beneficial uses, or increases from normal background light penetration or turbidity greater than 10 percent in areas where natural turbidity is greater than 50 nephelometric turbidity units;
  7. Coloration that causes nuisance or adversely affects beneficial uses;
  8. Visible, floating, suspended, or deposited oil or other products of petroleum origin; or
  9. Toxic or other deleterious substances in concentrations or quantities that cause deleterious effects on wildlife, waterfowl, or other aquatic biota, or render any of these unfit for human consumption, either at levels created in the receiving waters or as a result of biological concentration.
- B.** The discharge shall not cause the following limits to be exceeded in receiving waters at any place within one foot of the water surface:
1. Dissolved Oxygen            5.0 mg/L, minimum  
The median dissolved oxygen concentration for any three consecutive months shall not be less than 80% of the dissolved oxygen content at saturation. When natural factors cause concentrations less than that specified above, the discharge shall not cause further reduction in ambient dissolved oxygen concentrations.
  2. Dissolved Sulfide            Natural background levels
  3. pH                                The pH shall not be depressed below 6.5 or raised above 8.5. The discharge shall not cause changes greater than 0.5 pH units in normal ambient pH levels.
  4. Nutrients                        Waters shall not contain biostimulatory substances in concentrations that promote aquatic growths to the extent that such growths cause nuisance or adversely affect beneficial uses.
- C.** The discharge shall not cause a violation of any water quality standard for receiving waters adopted by the Regional Water Board or the State Water Resources Control Board (State Water Board) as required by the CWA and regulations adopted thereunder. If more stringent water quality standards are promulgated or approved pursuant to CWA section 303, or amendments thereto, the Regional Water Board may revise or modify this Order in accordance with the more stringent standards.

## **VI. PROVISIONS**

### **A. Standard Provisions**

1. The Discharger shall comply with all “Standard Provisions” in Attachment D.
2. The Discharger shall comply with all applicable provisions of the “Regional Standard Provisions, and Monitoring and Reporting Requirements for NPDES Wastewater Discharge Permits” (Attachment G).

### **B. Monitoring and Reporting**

The Discharger shall comply with the MRP (Attachment E) and future revisions thereto and applicable sampling and reporting requirements in Attachments D and G.

### **C. Special Provisions**

#### **1. Reopener Provisions**

The Regional Water Board may modify or reopen this Order prior to its expiration date in any of the following circumstances as allowed by law:

- a. If present or future investigations demonstrate that the discharges governed by this Order have or will have a reasonable potential to cause or contribute to, or will cease to have, adverse impacts on water quality or beneficial uses of the receiving waters.
- b. If new or revised WQOs or total maximum daily loads (TMDLs) come into effect for San Francisco Bay and contiguous water bodies (whether statewide, regional, or site-specific). In such cases, effluent limitations in this Order may be modified as necessary to reflect the updated WQOs and wasteload allocations in the TMDLs. Adoption of the effluent limitations in this Order is not intended to restrict in any way future modifications based on legally-adopted WQOs or TMDLs or as otherwise permitted under federal regulations governing NPDES permit modifications.
- c. If translator, dilution, or other water quality studies provide a basis for determining that a permit condition should be modified.
- d. If State Water Board precedential decisions, new policies, new laws, or new regulations are adopted.
- e. If an administrative or judicial decision on a separate NPDES permit or WDRs addresses requirements similar to this discharge.
- f. Or as otherwise authorized by law.

The Discharger may request a permit modification based on any of the circumstances above. With any such request, the Discharger shall include antidegradation and anti-backsliding analyses.

## 2. Effluent Characterization Study and Report

- a. Study Elements.** The Discharger shall continue to characterize and evaluate the discharge from the following discharge point to verify that the “no” or “unknown” reasonable potential analysis conclusions of this Order remain valid and to inform the next permit reissuance. The Discharger shall collect representative samples at the monitoring stations set forth below, as defined in the MRP, at no less than the frequency specified below:

<u>Discharge Point</u>	<u>Monitoring Location</u>	<u>Minimum Frequency</u>
001	EFF-001	Twice per year

The samples shall be analyzed for the pollutants listed in Attachment G, Table C, except for those pollutants with effluent limitations where the MRP already requires more frequent monitoring and except for those pollutants for which there are no water quality criteria (see Fact Sheet Table F-7). Compliance with this requirement shall be achieved in accordance with the specifications of Attachment G sections III.A.1 and III.A.2.

The Discharger shall evaluate on an annual basis if concentrations of any of these pollutants significantly increase over past performance. The Discharger shall investigate the cause of any such increase. The investigation may include, but need not be limited to, an increase in monitoring frequency, monitoring of internal process streams, and monitoring of influent sources. The Discharger shall establish remedial measures addressing any increase resulting in reasonable potential to cause or contribute to an excursion above applicable WQOs. This requirement may be satisfied through identification of the constituent as a “pollutant of concern” in the Discharger’s Pollutant Minimization Program, described in Provision VI.C.3.

### b. Reporting Requirements

- i. Routine Reporting.** The Discharger shall, within 45 days of receipt of analytical results, report the following in the transmittal letter for the appropriate self-monitoring report:
- (a) Indication that a sample for this characterization study was collected; and
  - (b) Identity of pollutants detected at or above applicable water quality criteria (see Fact Sheet Table F-7 for the criteria) and the detected concentrations of those pollutants.
- ii. Annual Reporting.** The Discharger shall summarize the annual data evaluation and source investigation in the annual self-monitoring report.
- iii. Final Report.** The Discharger shall submit a final report that presents all these data with the application for permit reissuance.

### 3. Pollutant Minimization Program

- a. The Discharger shall continue to improve its existing Pollutant Minimization Program to promote minimization of pollutant loadings to the treatment plant and therefore to the receiving waters.
- b. The Discharger shall submit an annual report no later than February 28 each year. Each annual report shall include at least the following information:
  - i. **Brief description of treatment plant.** The description shall include the treatment plant processes.
  - ii. **Discussion of current pollutants of concern.** Periodically, the Discharger shall analyze its circumstances to determine which pollutants are currently a problem and which pollutants may be potential future problems. This discussion shall include the reasons for choosing the pollutants.
  - iii. **Identification of sources for pollutants of concern.** This discussion shall include how the Discharger intends to estimate and identify pollutant sources. The Discharger shall include sources or potential sources not directly within the ability or authority of the Discharger to control, such as pollutants in the potable water supply and air deposition.
  - iv. **Identification of tasks to reduce the sources of pollutants of concern.** This discussion shall identify and prioritize tasks to address the Discharger's pollutants of concern. The Discharger may implement the tasks by itself or participate in group, regional, or national tasks that address its pollutants of concern. The Discharger is strongly encouraged to participate in group, regional, or national tasks that address its pollutants of concern whenever it is efficient and appropriate to do so. An implementation timeline shall be included for each task.
  - v. **Outreach to employees.** The Discharger shall inform employees about the pollutants of concern, potential sources, and how they might be able to help reduce the discharge of these pollutants of concern into the treatment facilities. The Discharger may provide a forum for employees to provide input.
  - vi. **Discussion of criteria used to measure Pollutant Minimization Program and task effectiveness.** The Discharger shall establish criteria to evaluate the effectiveness of its Pollutant Minimization Program. This discussion shall identify the specific criteria used to measure the effectiveness of each task in Provisions VI.C.3.b.iii, iv, and v.
  - vii. **Documentation of efforts and progress.** This discussion shall detail all of the Discharger's Pollutant Minimization Program activities during the reporting year.
  - viii. **Evaluation of Pollutant Minimization Program and tasks' effectiveness.** This Discharger shall use the criteria established in Provision VI.C.3.b.vii to evaluate the program and task effectiveness.

- ix. Identification of specific tasks and timelines for future efforts.** Based on the evaluation, the Discharger shall explain how it intends to continue or change its tasks to more effectively reduce the amount of pollutants flowing to the treatment plant and subsequently in its effluent.
- c.** The Discharger shall develop and conduct a Pollutant Minimization Program as further described below when there is evidence that a priority pollutant is present in the effluent above an effluent limitation (e.g., sample results reported as detected but not quantified [DNQ] when the effluent limitation is less than the method detection limit [MDL], sample results from analytical methods more sensitive than those methods required by this Order, presence of whole effluent toxicity, health advisories for fish consumption, or results of benthic or aquatic organism tissue sampling) and either:
- i.** A sample result is reported as DNQ and the effluent limitation is less than the Reporting Level (RL); or
  - ii.** A sample result is reported as not detected (ND) and the effluent limitation is less than the MDL, using definitions in Attachment A and reporting protocols described in the MRP.
- d.** If triggered by the reasons set forth in Provision VI.C.3.c, above, the Discharger's Pollutant Minimization Program shall include, but not be limited to, the following actions and submittals:
- i.** Annual review and semi-annual monitoring of potential sources of the reportable priority pollutants, which may include fish tissue monitoring and other bio-uptake sampling, or alternative measures when source monitoring is unlikely to produce useful analytical data;
  - ii.** Quarterly monitoring for the reportable priority pollutants in the influent to the treatment plant. The Executive Officer may approve alternative measures when influent monitoring is unlikely to produce useful analytical data;
  - iii.** Submittal of a control strategy designed to proceed toward the goal of maintaining concentrations of the reportable priority pollutants in the effluent at or below the effluent limitation;
  - iv.** Implementation of appropriate cost-effective control measures for the reportable priority pollutants, consistent with the control strategy; and
  - v.** Inclusion of the following specific items within the annual report required by Provision VI.C.3.b above:
    - (a)** All Pollutant Minimization Program monitoring results for the previous year;
    - (b)** List of potential sources of the reportable priority pollutants;
    - (c)** Summary of all actions undertaken pursuant to the control strategy; and
    - (d)** Description of actions to be taken in the following year.



**4. Other Special Provisions**

- a. Copper Action Plan.** The Discharger shall implement source control, and pollution prevention for copper in accordance with the following tasks and time schedule:

**Table 11. Copper Action Plan**

Task	Compliance Date
<p><b>1. Review Potential Copper Sources</b>                      The Discharger shall submit an inventory of potential copper sources to the treatment plant.</p>	<p>Submitted with the pollution prevention report in 2011.</p>
<p><b>2. Implement Copper Control Program</b>                      The Discharger shall submit a plan for and begin implementation of a program to reduce copper sources identified in Task 1.</p>	<p>Submitted June 30, 2011.</p>
<p><b>3. Implement Additional Measures</b>                      If the Regional Water Board notifies the Discharger that the three-year rolling mean dissolved copper concentration in Suisun Bay exceeds 2.8 µg/L, then within 90 days of the notification, the Discharger shall evaluate the effluent copper concentration trend and, if it is increasing, develop and begin implementation of additional measures to control copper discharges. The Discharger shall report on the progress and effectiveness of actions taken and provide a schedule for actions to be taken in the next 12 months.</p>	<p>If required, with next annual pollution prevention report due February 28 following 90 days after notification.</p>
<p><b>4. Undertake Studies to Reduce Copper Pollutant Impact Uncertainties</b>                      The Discharger shall submit an updated study plan and schedule to conduct or cause to be conducted technical studies to investigate possible copper sediment toxicity and to investigate sub-lethal effects on salmonids. Specifically, the Discharger shall include the manner in which the above will be accomplished and describe the studies to be performed with an implementation schedule. To satisfy this requirement, the Discharger may collaborate and conduct these studies as a group.</p>	<p>Submitted January 6, 2011, as part of a group.</p>
<p><b>5. Report Status of Copper Control Program</b>                      The Discharger shall submit an annual report documenting copper control program implementation and addressing the effectiveness of the actions taken, including any additional copper controls required by Task 3 above, and provide a schedule for actions to be taken in the next 12 months. Additionally, the Discharger shall report the findings and results of the studies completed, planned, or in progress under Task 4. Regarding Task 4 studies, dischargers may collaborate and provide this information in a single report to satisfy this requirement for an entire group.</p>	<p>With annual pollution prevention report due February 28 each year</p>

- b. Cyanide Action Plan.** The Discharger shall implement monitoring and surveillance, source control and pollution prevention for cyanide in accordance with the following tasks and time schedule:

**Table 12. Cyanide Action Plan**

Task	Compliance Date
<p><b>1. Review Potential Cyanide Sources</b>                      The Discharger shall submit an inventory of potential cyanide sources to the treatment plant.</p>	<p>Submitted June 8, 2010.</p>
<p><b>2. Implement Cyanide Control Program</b>                      The Discharger shall continue to implement its program to minimize cyanide discharges consisting, at a minimum, of the following elements:</p> <ol style="list-style-type: none"> <li>a. Inspect each potential source to assess the need to include that source in the control program.</li> <li>b. Prepare an emergency monitoring and response plan to be implemented if a</li> </ol>	<p>Submitted with the pollution prevention report in 2011.</p>

Task	Compliance Date
significant cyanide discharge occurs.	
<p><b>3. Implement Additional Measures</b>                      If the Regional Water Board notifies the Discharger that ambient monitoring shows cyanide concentrations are 1.0 µg/L or higher in the main body of San Francisco Bay, then within 90 days of the notification, the Discharger shall commence actions to identify and abate cyanide sources responsible for the elevated ambient concentrations, and shall report on the progress and effectiveness of actions taken and provide a schedule for actions to be taken in the next 12 months.</p>	<p>If required, with next annual pollution prevention report due February 28 following 90 days after notification</p>
<p><b>4. Report Status of Cyanide Control Program</b>                      The Discharger shall submit an annual report documenting cyanide control program implementation and addressing the effectiveness of actions taken, including any additional cyanide controls required by Task 3 above and provide a schedule for actions to be taken in the next 12 months.</p>	<p>With annual pollution prevention report due February 28 each year</p>

**c. Stormwater Pollution Prevention Plan and Annual Report**

By October 1, 2015, the Discharger shall submit and implement an updated Stormwater Pollution Prevention Plan (SWPPP). The updated SWPPP shall include best management practices for Tesoro’s Avon Wharf. These best management practices shall, at a minimum, comply with the measures pertaining to stormwater included in the California State Lands Commission Final Environmental Impact Report, dated January 30, 2015, for the Tesoro Avon Marine Oil Terminal Lease Consideration Project. To address elevated levels of TSS in stormwater runoff at compliance points T4NW and T2S-B, the Discharger shall install underground settlement collection vaults at these two locations and shall certify it has done so in the SWPPP.

In subsequent years, the Discharger shall update and submit an updated SWPPP acceptable to the Executive Officer by October 1. If the Discharger determines that it does not need to update its SWPPP, it shall submit a letter to the Executive Officer indicating that no revisions are necessary and stating the last year it updated its SWPPP. The Discharger shall implement each subsequent SWPPP update. The SWPPP shall comply with the requirements in the Federal Standard Provisions (Attachment D).

The Discharger shall submit an annual stormwater report by July 1 of each year covering data for the previous wet weather season for the identified stormwater discharge points. The annual stormwater report shall, at a minimum, include:

- (a) a tabulated summary of all sampling results and a summary of visual observations taken during inspections;
- (b) a comprehensive discussion of the compliance record and any corrective actions taken or planned to ensure compliance with WDRs; and
- (c) a comprehensive discussion of source identification and control programs for total suspended solids.

**d. Construction and Development Requirements for Stormwater**

These requirements apply to development and construction activities that occur in areas where stormwater is not subject to physical treatment. These requirements do not apply to stormwater that drains to Tesoro's wastewater treatment plant or stormwater that is treated in earthen basins via physical settling.

In areas where stormwater is not subject to physical treatment, the Discharger shall obtain coverage under applicable requirements of *NPDES General Permit for Stormwater Discharges Associated with Construction and Land Disturbance Activities* Order No. 2009-0009-DWQ.

**e. Conditions for Mass and Concentration Adjustments for Recycled Water**

Prior to making adjustments for mass or concentration limits for recycled water use, the Discharger shall satisfy all of the following conditions:

- (a) Submit a technical report that demonstrates such adjustments will not cause impairment of beneficial uses in the vicinity of the discharge, such as an acutely toxic zone to aquatic organisms. The demonstration shall include, but not be limited to, an assessment of the results of whole effluent toxicity testing and mass balance calculations that compare the as-discharged effluent concentrations (i.e., before adjustments) to potential water quality-based effluent limits for constituent(s) for which adjustments are sought.
- (b) Submit one or more examples of how the adjustment calculations will be performed and reported.
- (c) Obtain written approval from the Executive Officer.

## ATTACHMENT A – DEFINITIONS

### **Arithmetic Mean ( $\mu$ )**

Also called the average, the sum of measured values divided by the number of samples. For ambient water concentrations, the arithmetic mean is calculated as follows:

$$\text{Arithmetic mean} = \mu = \Sigma x / n \quad \text{where: } \Sigma x \text{ is the sum of the measured ambient water concentrations, and } n \text{ is the number of samples.}$$

### **Average Monthly Effluent Limitation (AMEL)**

The highest allowable average of daily discharges over a calendar month, calculated as the sum of all daily discharges measured during a calendar month divided by the number of daily discharges measured during that month.

### **Average Weekly Effluent Limitation (AWEL)**

The highest allowable average of daily discharges over a calendar week (Sunday through Saturday), calculated as the sum of all daily discharges measured during a calendar week divided by the number of daily discharges measured during that week.

### **Bioaccumulative**

Taken up by an organism from its surrounding medium through gill membranes, epithelial tissue, or from food and subsequently concentrated and retained in the body of the organism.

### **Carcinogenic**

Known to cause cancer in living organisms.

### **Coefficient of Variation**

Measure of data variability calculated as the estimated standard deviation divided by the arithmetic mean of the observed values.

### **Daily Discharge**

Either: (1) the total mass of the constituent discharged over the calendar day (12:00 am through 11:59 pm) or any 24-hour period that reasonably represents a calendar day for purposes of sampling (as specified in the permit) for a constituent with limitations expressed in units of mass; or (2) the unweighted arithmetic mean measurement of the constituent over the day for a constituent with limitations expressed in other units of measurement (e.g., concentration).

The daily discharge may be determined by the analytical results of a composite sample taken over the course of one day (a calendar day or other 24-hour period defined as a day) or by the arithmetic mean of analytical results from one or more grab samples taken over the course of the day.

For composite sampling, if 1 day is defined as a 24-hour period other than a calendar day, the analytical result for the 24-hour period is considered the result for the calendar day in which the 24-hour period ends.

### **Detected, but Not Quantified (DNQ)**

Sample result less than the RL, but greater than or equal to the laboratory's MDL. Sample results reported as DNQ are estimated concentrations.

### **Dilution Credit**

Amount of dilution granted to a discharge in the calculation of a water quality-based effluent limitation, based on the allowance of a specified mixing zone. It is calculated from the dilution ratio or determined by conducting a mixing zone study or modeling the discharge and receiving water.

### **Effluent Concentration Allowance (ECA)**

Value derived from the water quality criterion/objective, dilution credit, and ambient background concentration that is used, in conjunction with the CV for the effluent monitoring data, to calculate a long-term average (LTA) discharge concentration. The ECA has the same meaning as waste load allocation (WLA) as used in U.S. EPA guidance (*Technical Support Document For Water Quality-based Toxics Control*, March 1991, second printing, EPA/505/2-90-001).

### **Enclosed Bay**

Indentation along the coast that encloses an area of oceanic water within a distinct headlands or harbor works. Enclosed bays include all bays where the narrowest distance between the headlands or outermost harbor works is less than 75 percent of the greatest dimension of the enclosed portion of the bay. Enclosed bays include, but are not limited to, Humboldt Bay, Bodega Harbor, Tomales Bay, Drake's Estero, San Francisco Bay, Morro Bay, Los Angeles-Long Beach Harbor, Upper and Lower Newport Bay, Mission Bay, and San Diego Bay. Enclosed bays do not include inland surface waters or ocean waters.

### **Estimated Chemical Concentration**

Concentration that results from the confirmed detection of the substance below the ML value by the analytical method.

### **Estuaries**

Waters, including coastal lagoons, located at the mouths of streams that serve as areas of mixing for fresh and ocean waters. Coastal lagoons and mouths of streams that are temporarily separated from the ocean by sandbars are considered estuaries. Estuarine waters are considered to extend from a bay or the open ocean to a point upstream where there is no significant mixing of fresh water and seawater. Estuarine waters include, but are not limited to, the Sacramento-San Joaquin Delta, as defined in Water Code section 12220, Suisun Bay, Carquinez Strait downstream to the Carquinez Bridge, and appropriate areas of the Smith, Mad, Eel, Noyo, Russian, Klamath, San Diego, and Otay rivers. Estuaries do not include inland surface waters or ocean waters.

### **Inland Surface Waters**

All surface waters of the state that do not include the ocean, enclosed bays, or estuaries.

### **Instantaneous Maximum Effluent Limitation**

Highest allowable value for any single grab sample or aliquot (i.e., each grab sample or aliquot is independently compared to the instantaneous maximum limitation).

### **Instantaneous Minimum Effluent Limitation**

Lowest allowable value for any single grab sample or aliquot (i.e., each grab sample or aliquot is independently compared to the instantaneous minimum limitation).

**Maximum Daily Effluent Limitation (MDEL)**

Highest allowable daily discharge of a pollutant, over a calendar day (or 24-hour period). For pollutants with limitations expressed in units of mass, the daily discharge is calculated as the total mass of the pollutant discharged over the day. For pollutants with limitations expressed in other units of measurement, the daily discharge is calculated as the arithmetic mean measurement of the pollutant over the day.

**Median**

Middle measurement in a set of data. The median of a set of data is found by first arranging the measurements in order of magnitude (either increasing or decreasing order). If the number of measurements (n) is odd, then the median =  $X_{(n+1)/2}$ . If n is even, then the median =  $(X_{n/2} + X_{(n/2)+1})/2$  (i.e., the midpoint between n/2 and n/2+1).

**Method Detection Limit (MDL)**

Minimum concentration of a substance that can be measured and reported with 99 percent confidence that the analyte concentration is greater than zero, as defined in 40 C.F.R. part 136, Attachment B, revised as of July 3, 1999.

**Minimum Level (ML)**

Concentration at which the entire analytical system gives a recognizable signal and acceptable calibration point. The ML is the concentration in a sample that is equivalent to the concentration of the lowest calibration standard analyzed by a specific analytical procedure, assuming that all the method specified sample weights, volumes, and processing steps have been followed.

**Mixing Zone**

Limited volume of receiving water allocated for mixing with a wastewater discharge where water quality criteria can be exceeded without causing adverse effects to the overall water body.

**Not Detected (ND)**

Sample results less than the laboratory's MDL.

**Persistent Pollutants**

Substances for which degradation or decomposition in the environment is nonexistent or very slow.

**Pollutant Minimization Program**

Program of waste minimization and pollution prevention actions that include, but are not limited to, product substitution, waste stream recycling, alternative waste management methods, and education of the public and businesses. The goal of the Pollutant Minimization Program is to reduce all potential sources of a priority pollutant through pollutant minimization (control) strategies, including pollution prevention measures as appropriate, to maintain the effluent concentration at or below the water quality-based effluent limitation. Pollution prevention measures may be particularly appropriate for persistent bioaccumulative priority pollutants where there is evidence that beneficial uses are being impacted. Cost effectiveness may be considered when establishing the requirements of a Pollutant Minimization Program. The completion and implementation of a Pollution Prevention Plan, if required pursuant to Water Code section 13263.3(d), is considered to fulfill Pollutant Minimization Program requirements.

### **Pollution Prevention**

Any action that causes a net reduction in the use or generation of a hazardous substance or other pollutant that is discharged into water and includes, but is not limited to, input change, operational improvement, production process change, and product reformulation (as defined in Water Code section 13263.3). Pollution prevention does not include actions that merely shift a pollutant in wastewater from one environmental medium to another environmental medium, unless clear environmental benefits of such an approach are identified to the satisfaction of the State Water Board or Regional Water Board.

### **Reporting Level (RL)**

ML (and its associated analytical method) chosen by the Discharger for reporting and compliance determination from the MLs included in this Order, including an additional factor if applicable as discussed herein. The MLs included in this Order correspond to approved analytical methods for reporting a sample result that are selected by the Regional Water Board either from SIP Appendix 4 in accordance with SIP section 2.4.2 or established in accordance with SIP section 2.4.3. The ML is based on the proper application of method-based analytical procedures for sample preparation and the absence of any matrix interferences. Other factors may be applied to the ML depending on the specific sample preparation steps employed. For example, the treatment typically applied in cases where there are matrix-effects is to dilute the sample or sample aliquot by a factor of ten. In such cases, this additional factor must be applied to the ML in the computation of the RL.

### **Source of Drinking Water**

Any water designated as having a municipal or domestic supply (MUN) beneficial use.

### **Standard Deviation ( $\sigma$ )**

Measure of variability calculated as follows:

$$\sigma = \left( \frac{\sum[(x - \mu)^2]}{(n - 1)} \right)^{0.5}$$

where:

x is the observed value;

$\mu$  is the arithmetic mean of the observed values; and

n is the number of samples.

### **Toxicity Reduction Evaluation (TRE)**

Study conducted in a step-wise process designed to identify the causative agents of effluent or ambient toxicity, isolate the sources of toxicity, evaluate the effectiveness of toxicity control options, and then confirm the reduction in toxicity. The first steps of the TRE consist of the collection of data relevant to the toxicity, including additional toxicity testing, and an evaluation of facility operations and maintenance practices, and best management practices. A Toxicity Identification Evaluation (TIE) may be required as part of the TRE, if appropriate. A TIE is a set of procedures to identify the specific chemicals responsible for toxicity. These procedures are performed in three phases (characterization, identification, and confirmation) using aquatic organism toxicity tests.

### ATTACHMENT B – FACILITY MAP

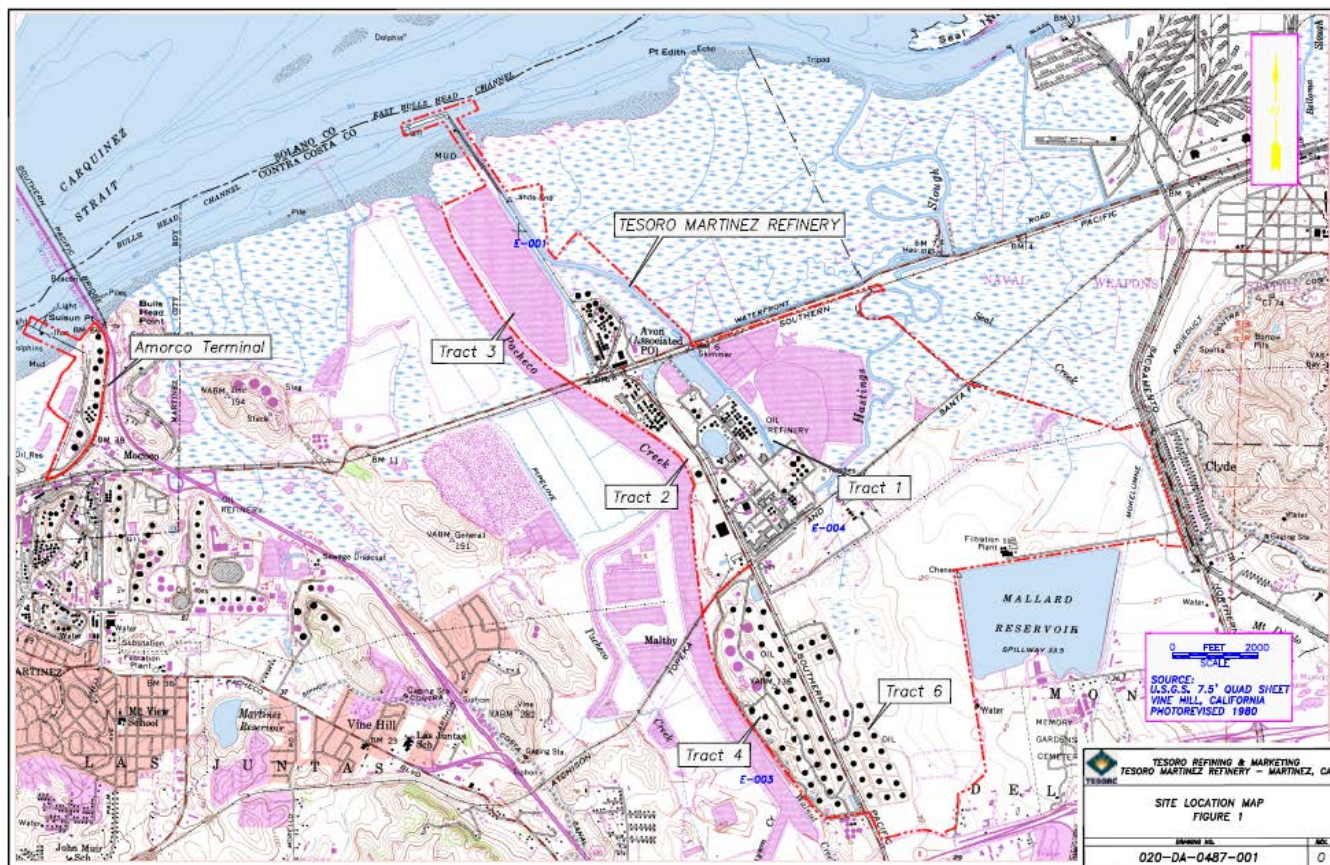



**ATTACHMENT C – PROCESS FLOW DIAGRAM**

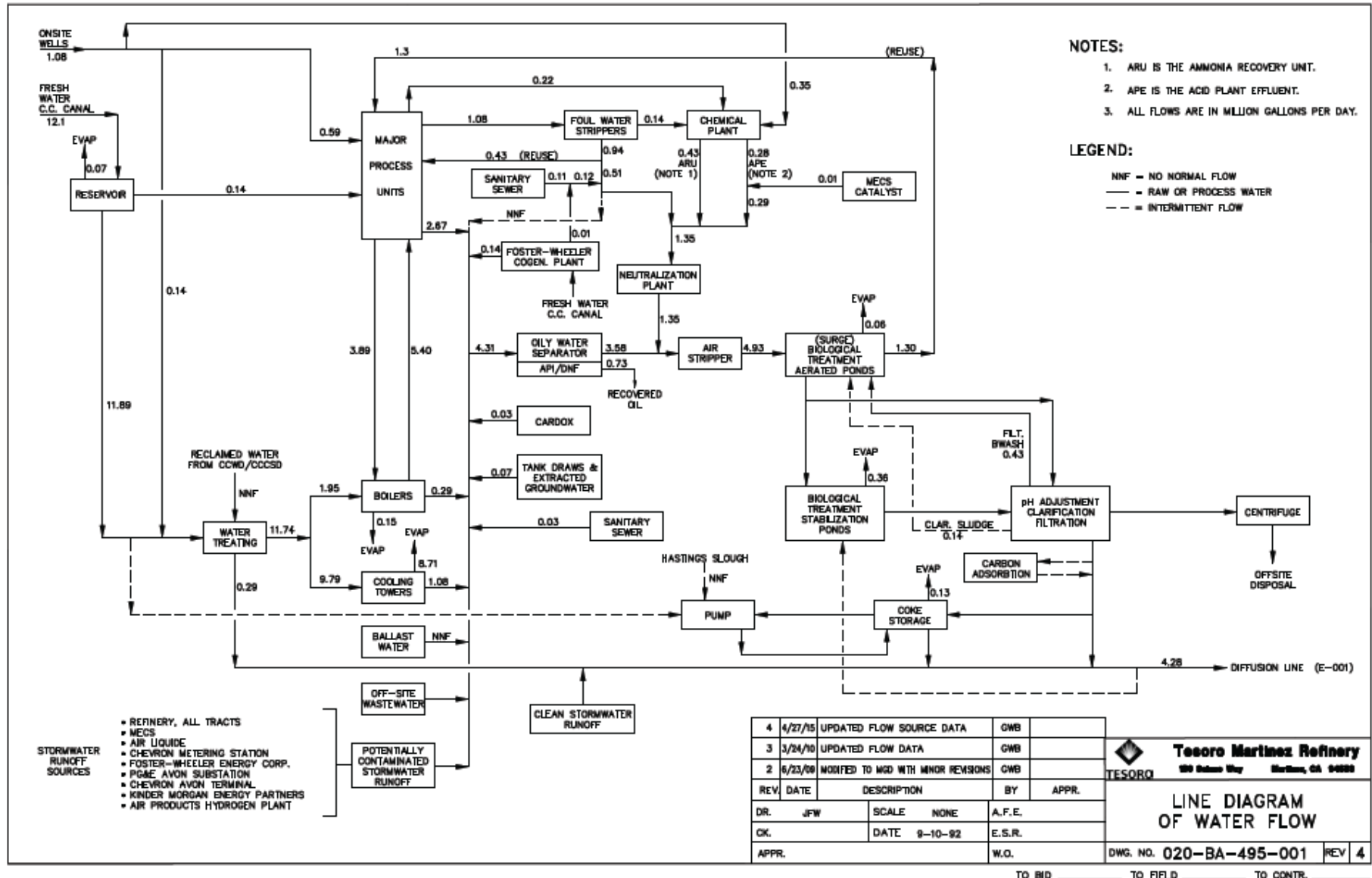

## **ATTACHMENT D –STANDARD PROVISIONS**

### **I. STANDARD PROVISIONS – PERMIT COMPLIANCE**

#### **A. Duty to Comply**

1. The Discharger must comply with all of the terms, requirements, and conditions of this Order. Any noncompliance constitutes a violation of the Clean Water Act (CWA) and the California Water Code and is grounds for enforcement action; permit termination, revocation and reissuance, or modification; denial of a permit renewal application; or a combination thereof. (40 C.F.R. § 122.41(a); Wat. Code §§ 13261, 13263, 13265, 13268, 13000, 13001, 13304, 13350, 13385.)
2. The Discharger shall comply with effluent standards or prohibitions established under CWA section 307(a) for toxic pollutants and with standards for sewage sludge use or disposal established under CWA section 405(d) within the time provided in the regulations that establish these standards or prohibitions, even if this Order has not yet been modified to incorporate the requirement. (40 C.F.R. § 122.41(a)(1).)

#### **B. Need to Halt or Reduce Activity Not a Defense**

It shall not be a defense for a Discharger in an enforcement action that it would have been necessary to halt or reduce the permitted activity in order to maintain compliance with the conditions of this Order. (40 C.F.R. § 122.41(c).)

#### **C. Duty to Mitigate**

The Discharger shall take all reasonable steps to minimize or prevent any discharge or sludge use or disposal in violation of this Order that has a reasonable likelihood of adversely affecting human health or the environment. (40 C.F.R. § 122.41(d).)

#### **D. Proper Operation and Maintenance**

The Discharger shall at all times properly operate and maintain all facilities and systems of treatment and control (and related appurtenances) which are installed or used by the Discharger to achieve compliance with the conditions of this Order. Proper operation and maintenance also includes adequate laboratory controls and appropriate quality assurance procedures. This provision requires the operation of backup or auxiliary facilities or similar systems that are installed by a Discharger only when necessary to achieve compliance with the conditions of this Order. (40 C.F.R. § 122.41(e).)

#### **E. Property Rights**

1. This Order does not convey any property rights of any sort or any exclusive privileges. (40 C.F.R. § 122.41(g).)
2. The issuance of this Order does not authorize any injury to persons or property or invasion of other private rights, or any infringement of state or local law or regulations. (40 C.F.R. § 122.5(c).)

## F. Inspection and Entry

The Discharger shall allow the Regional Water Board, State Water Board, U.S. EPA, and/or their authorized representatives (including an authorized contractor acting as their representative), upon the presentation of credentials and other documents, as may be required by law, to (33 U.S.C. § 1318(a)(4)(B); 40 C.F.R. § 122.41(i); Wat. Code, §§ 13267, 13383):

1. Enter upon the Discharger's premises where a regulated facility or activity is located or conducted, or where records are kept under the conditions of this Order (33 U.S.C. § 1318(a)(4)(B)(i); 40 C.F.R. § 122.41(i)(1); Wat. Code, §§ 13267, 13383);
2. Have access to and copy, at reasonable times, any records that must be kept under the conditions of this Order (33 U.S.C. § 1318(a)(4)(B)(ii); 40 C.F.R. § 122.41(i)(2)); Wat. Code, §§ 13267, 13383);
3. Inspect and photograph, at reasonable times, any facilities, equipment (including monitoring and control equipment), practices, or operations regulated or required under this Order (33 U.S.C. § 1318(a)(4)(B)(ii); 40 C.F.R. § 122.41(i)(3); Wat. Code, §§ 13267, 13383); and
4. Sample or monitor, at reasonable times, for the purposes of ensuring Order compliance or as otherwise authorized by the CWA or the Water Code, any substances or parameters at any location. (33 U.S.C. § 1318(a)(4)(B); 40 C.F.R. § 122.41(i)(4); Wat. Code, §§ 13267, 13383.)

## G. Bypass

### 1. Definitions

- a. "Bypass" means the intentional diversion of waste streams from any portion of a treatment facility. (40 C.F.R. § 122.41(m)(1)(i).)
- b. "Severe property damage" means substantial physical damage to property, damage to the treatment facilities, which causes them to become inoperable, or substantial and permanent loss of natural resources that can reasonably be expected to occur in the absence of a bypass. Severe property damage does not mean economic loss caused by delays in production. (40 C.F.R. § 122.41(m)(1)(ii).)

2. **Bypass not exceeding limitations.** The Discharger may allow any bypass to occur which does not cause exceedances of effluent limitations, but only if it is for essential maintenance to assure efficient operation. These bypasses are not subject to the provisions listed in Standard Provisions – Permit Compliance I.G.3, I.G.4, and I.G.5 below. (40 C.F.R. § 122.41(m)(2).)
3. **Prohibition of bypass.** Bypass is prohibited, and the Regional Water Board may take enforcement action against a Discharger for bypass, unless (40 C.F.R. § 122.41(m)(4)(i)):
  - a. Bypass was unavoidable to prevent loss of life, personal injury, or severe property damage (40 C.F.R. § 122.41(m)(4)(i)(A));

- b. There were no feasible alternatives to the bypass, such as the use of auxiliary treatment facilities, retention of untreated wastes, or maintenance during normal periods of equipment downtime. This condition is not satisfied if adequate back-up equipment should have been installed in the exercise of reasonable engineering judgment to prevent a bypass that occurred during normal periods of equipment downtime or preventive maintenance (40 C.F.R. § 122.41(m)(4)(i)(B)); and
  - c. The Discharger submitted notice to the Regional Water Board as required under Standard Provisions – Permit Compliance I.G.5 below. (40 C.F.R. § 122.41(m)(4)(i)(C).)
4. **Approval.** The Regional Water Board may approve an anticipated bypass, after considering its adverse effects, if the Regional Water Board determines that it will meet the three conditions listed in Standard Provisions—Permit Compliance I.G.3 above. (40 C.F.R. § 122.41(m)(4)(ii).)

#### 5. Notice

- a. **Anticipated bypass.** If the Discharger knows in advance of the need for a bypass, it shall submit a notice, if possible at least 10 days before the date of the bypass. (40 C.F.R. § 122.41(m)(3)(i).)
- b. **Unanticipated bypass.** The Discharger shall submit notice of an unanticipated bypass as required in Standard Provisions - Reporting V.E below (24-hour notice). (40 C.F.R. § 122.41(m)(3)(ii).)

#### H. Upset

Upset means an exceptional incident in which there is unintentional and temporary noncompliance with technology based permit effluent limitations because of factors beyond the reasonable control of the Discharger. An upset does not include noncompliance to the extent caused by operational error, improperly designed treatment facilities, inadequate treatment facilities, lack of preventive maintenance, or careless or improper operation. (40 C.F.R. § 122.41(n)(1).)

- 1. **Effect of an upset.** An upset constitutes an affirmative defense to an action brought for noncompliance with such technology based permit effluent limitations if the requirements of Standard Provisions – Permit Compliance I.H.2 below are met. No determination made during administrative review of claims that noncompliance was caused by upset, and before an action for noncompliance, is final administrative action subject to judicial review. (40 C.F.R. § 122.41(n)(2).)
- 2. **Conditions necessary for a demonstration of upset.** A Discharger who wishes to establish the affirmative defense of upset shall demonstrate, through properly signed, contemporaneous operating logs or other relevant evidence that (40 C.F.R. § 122.41(n)(3)):
  - a. An upset occurred and that the Discharger can identify the cause(s) of the upset (40 C.F.R. § 122.41(n)(3)(i));
  - b. The permitted facility was, at the time, being properly operated (40 C.F.R. § 122.41(n)(3)(ii));

- c. The Discharger submitted notice of the upset as required in Standard Provisions—Reporting V.E.2.b below (24-hour notice) (40 C.F.R. § 122.41(n)(3)(iii)); and
  - d. The Discharger complied with any remedial measures required under Standard Provisions—Permit Compliance I.C above. (40 C.F.R. § 122.41(n)(3)(iv).)
3. **Burden of proof.** In any enforcement proceeding, the Discharger seeking to establish the occurrence of an upset has the burden of proof. (40 C.F.R. § 122.41(n)(4).)

## II. STANDARD PROVISIONS—PERMIT ACTION

### A. General

This Order may be modified, revoked and reissued, or terminated for cause. The filing of a request by the Discharger for modification, revocation and reissuance, or termination, or a notification of planned changes or anticipated noncompliance does not stay any Order condition. (40 C.F.R. § 122.41(f).)

### B. Duty to Reapply

If the Discharger wishes to continue an activity regulated by this Order after the expiration date of this Order, the Discharger must apply for and obtain a new permit. (40 C.F.R. § 122.41(b).)

### C. Transfers

This Order is not transferable to any person except after notice to the Regional Water Board. The Regional Water Board may require modification or revocation and reissuance of the Order to change the name of the Discharger and incorporate such other requirements as may be necessary under the CWA and the Water Code. (40 C.F.R. §§ 122.41(l)(3), 122.61.)

## III. STANDARD PROVISIONS – MONITORING

- A. Samples and measurements taken for the purpose of monitoring shall be representative of the monitored activity. (40 C.F.R. § 122.41(j)(1).)
- B. Monitoring results must be conducted according to test procedures approved under 40 C.F.R. part 136 for the analyses of pollutants unless another method is required under 40 C.F.R. subchapters N or O. In the case of pollutants for which there are no approved methods under 40 C.F.R. part 136 or otherwise required under 40 C.F.R. subchapters N or O, monitoring must be conducted according to a test procedure specified in this Order for such pollutants. (40 C.F.R. §§ 122.41(j)(4), 122.44(i)(1)(iv).)

## IV. STANDARD PROVISIONS—RECORDS

- A. Except for records of monitoring information required by this Order related to the Discharger's sewage sludge use and disposal activities, which shall be retained for a period of at least five years (or longer as required by 40 C.F.R. part 503), the Discharger shall retain records of all monitoring information, including all calibration and maintenance records and all original strip chart recordings for continuous monitoring instrumentation, copies of all reports required by this Order, and records of all data used to complete the application for this Order, for a period of at least three (3) years

from the date of the sample, measurement, report or application. This period may be extended by request of the Regional Water Board Executive Officer at any time. (40 C.F.R. § 122.41(j)(2).)

**B. Records of monitoring information shall include the following:**

1. The date, exact place, and time of sampling or measurements (40 C.F.R. § 122.41(j)(3)(i));
2. The individual(s) who performed the sampling or measurements (40 C.F.R. § 122.41(j)(3)(ii));
3. The date(s) the analyses were performed (40 C.F.R. § 122.41(j)(3)(iii));
4. The individual(s) who performed the analyses (40 C.F.R. § 122.41(j)(3)(iv));
5. The analytical techniques or methods used (40 C.F.R. § 122.41(j)(3)(v)); and
6. The results of such analyses. (40 C.F.R. § 122.41(j)(3)(vi).)

**C. Claims of confidentiality for the following information will be denied (40 C.F.R. § 122.7(b)):**

1. The name and address of any permit applicant or Discharger (40 C.F.R. § 122.7(b)(1)); and
2. Permit applications and attachments, permits, and effluent data. (40 C.F.R. § 122.7(b)(2).)

**V. STANDARD PROVISIONS—REPORTING**

**A. Duty to Provide Information**

The Discharger shall furnish to the Regional Water Board, State Water Board, or U.S. EPA within a reasonable time, any information which the Regional Water Board, State Water Board, or U.S. EPA may request to determine whether cause exists for modifying, revoking and reissuing, or terminating this Order or to determine compliance with this Order. Upon request, the Discharger shall also furnish to the Regional Water Board, State Water Board, or U.S. EPA copies of records required to be kept by this Order. (40 C.F.R. § 122.41(h); Wat. Code, §§ 13267, 13383.)

**B. Signatory and Certification Requirements**

1. All applications, reports, or information submitted to the Regional Water Board, State Water Board, and/or U.S. EPA shall be signed and certified in accordance with Standard Provisions—Reporting V.B.2, V.B.3, V.B.4, and V.B.5 below. (40 C.F.R. § 122.41(k).)
2. For a corporation, all permit applications shall be signed by a responsible corporate officer. For the purpose of this section, a responsible corporate officer means: (i) a president, secretary, treasurer, or vice-president of the corporation in charge of a principal business function, or any other person who performs similar policy- or decision-making functions for the corporation, or (ii) the manager of one or more manufacturing, production, or operating facilities, provided, the manager is authorized to make management decisions which govern the operation of the regulated facility including having the explicit or implicit duty of making major capital investment recommendations, and initiating and directing other comprehensive measures to assure long term environmental compliance with environmental laws and regulations; the manager can ensure that the necessary systems are established or actions

taken to gather complete and accurate information for permit application requirements; and where authority to sign documents has been assigned or delegated to the manager in accordance with corporate procedures. (40 C.F.R. § 122.22(a)(1).)

For a partnership or sole proprietorship, all permit applications shall be signed by a general partner or the proprietor, respectively. (40 C.F.R. § 122.22(a)(2).)

For a municipality, state, federal, or other public agency, all permit applications shall be signed by either a principal executive officer or ranking elected official. For purposes of this provision, a principal executive officer of a federal agency includes (i) the chief executive officer of the agency, or (ii) a senior executive officer having responsibility for the overall operations of a principal geographic unit of the agency (e.g., Regional Administrators of U.S. EPA). (40 C.F.R. § 122.22(a)(3).)

3. All reports required by this Order and other information requested by the Regional Water Board, State Water Board, or U.S. EPA shall be signed by a person described in Standard Provisions – Reporting V.B.2 above, or by a duly authorized representative of that person. A person is a duly authorized representative only if:
  - a. The authorization is made in writing by a person described in Standard Provisions—Reporting V.B.2 above (40 C.F.R. § 122.22(b)(1));
  - b. The authorization specifies either an individual or a position having responsibility for the overall operation of the regulated facility or activity such as the position of plant manager, operator of a well or a well field, superintendent, position of equivalent responsibility, or an individual or position having overall responsibility for environmental matters for the company. (A duly authorized representative may thus be either a named individual or any individual occupying a named position.) (40 C.F.R. § 122.22(b)(2)); and
  - c. The written authorization is submitted to the Regional Water Board and State Water Board. (40 C.F.R. § 122.22(b)(3).)
4. If an authorization under Standard Provisions – Reporting V.B.3 above is no longer accurate because a different individual or position has responsibility for the overall operation of the facility, a new authorization satisfying the requirements of Standard Provisions—Reporting V.B.3 above must be submitted to the Regional Water Board and State Water Board prior to or together with any reports, information, or applications, to be signed by an authorized representative. (40 C.F.R. § 122.22(c).)
5. Any person signing a document under Standard Provisions—Reporting V.B.2 or V.B.3 above shall make the following certification:

“I certify under penalty of law that this document and all attachments were prepared under my direction or supervision in accordance with a system designed to assure that qualified personnel properly gather and evaluate the information submitted. Based on my inquiry of the person or persons who manage the system or those persons directly responsible for gathering the information, the information submitted is, to the best of my knowledge and belief, true, accurate, and complete. I am aware that there are

significant penalties for submitting false information, including the possibility of fine and imprisonment for knowing violations.” (40 C.F.R. § 122.22(d).)

### **C. Monitoring Reports**

1. Monitoring results shall be reported at the intervals specified in the Monitoring and Reporting Program in this Order. (40 C.F.R. § 122.22(l)(4).)
2. Monitoring results must be reported on a Discharge Monitoring Report (DMR) form or forms provided or specified by the Regional Water Board or State Water Board for reporting results of monitoring of sludge use or disposal practices. (40 C.F.R. § 122.41(l)(4)(i).)
3. If the Discharger monitors any pollutant more frequently than required by this Order using test procedures approved under 40 C.F.R. part 136, or another method required for an industry-specific waste stream under 40 C.F.R. subchapters N or O, the results of such monitoring shall be included in the calculation and reporting of the data submitted in the DMR or sludge reporting form specified by the Regional Water Board. (40 C.F.R. § 122.41(l)(4)(ii).)
4. Calculations for all limitations, which require averaging of measurements, shall utilize an arithmetic mean unless otherwise specified in this Order. (40 C.F.R. § 122.41(l)(4)(iii).)

### **D. Compliance Schedules**

Reports of compliance or noncompliance with, or any progress reports on, interim and final requirements contained in any compliance schedule of this Order, shall be submitted no later than 14 days following each schedule date. (40 C.F.R. § 122.41(l)(5).)

### **E. Twenty-Four Hour Reporting**

1. The Discharger shall report any noncompliance that may endanger health or the environment. Any information shall be provided orally within 24 hours from the time the Discharger becomes aware of the circumstances. A written submission shall also be provided within five (5) days of the time the Discharger becomes aware of the circumstances. The written submission shall contain a description of the noncompliance and its cause; the period of noncompliance, including exact dates and times, and if the noncompliance has not been corrected, the anticipated time it is expected to continue; and steps taken or planned to reduce, eliminate, and prevent reoccurrence of the noncompliance. (40 C.F.R. § 122.41(l)(6)(i).)
2. The following shall be included as information that must be reported within 24 hours under this paragraph (40 C.F.R. § 122.41(l)(6)(ii)):
  - a. Any unanticipated bypass that exceeds any effluent limitation in this Order. (40 C.F.R. § 122.41(l)(6)(ii)(A).)
  - b. Any upset that exceeds any effluent limitation in this Order. (40 C.F.R. § 122.41(l)(6)(ii)(B).)



3. The Regional Water Board may waive the above-required written report under this provision on a case-by-case basis if an oral report has been received within 24 hours. (40 C.F.R. § 122.41(l)(6)(iii).)

## **F. Planned Changes**

The Discharger shall give notice to the Regional Water Board as soon as possible of any planned physical alterations or additions to the permitted facility. Notice is required under this provision only when (40 C.F.R. § 122.41(l)(1)):

1. The alteration or addition to a permitted facility may meet one of the criteria for determining whether a facility is a new source in 40 C.F.R. section 122.29(b) (40 C.F.R. § 122.41(l)(1)(i)); or
2. The alteration or addition could significantly change the nature or increase the quantity of pollutants discharged. This notification applies to pollutants that are not subject to effluent limitations in this Order. (Alternatively, for an existing manufacturing, commercial, mining, or silvicultural discharge as referenced in 40 C.F.R. section 122.42(a), this notification applies to pollutants that are subject neither to effluent limitations in this Order nor to notification requirements under 40 C.F.R. section 122.42(a)(1) (see Additional Provisions—Notification Levels VII.A.1).) (40 C.F.R. § 122.41(l)(1)(ii).)
3. The alteration or addition results in a significant change in the Discharger's sludge use or disposal practices, and such alteration, addition, or change may justify the application of permit conditions that are different from or absent in the existing permit, including notification of additional use or disposal sites not reported during the permit application process or not reported pursuant to an approved land application plan. (40 C.F.R. § 122.41(l)(1)(iii).)

## **G. Anticipated Noncompliance**

The Discharger shall give advance notice to the Regional Water Board or State Water Board of any planned changes in the permitted facility or activity that may result in noncompliance with this Order's requirements. (40 C.F.R. § 122.41(l)(2).)

## **H. Other Noncompliance**

The Discharger shall report all instances of noncompliance not reported under Standard Provisions—Reporting V.C, V.D, and V.E above at the time monitoring reports are submitted. The reports shall contain the information listed in Standard Provision—Reporting V.E above. (40 C.F.R. § 122.41(l)(7).)

## **I. Other Information**

When the Discharger becomes aware that it failed to submit any relevant facts in a permit application, or submitted incorrect information in a permit application or in any report to the Regional Water Board, State Water Board, or U.S. EPA, the Discharger shall promptly submit such facts or information. (40 C.F.R. § 122.41(l)(8).)

## **VI. STANDARD PROVISIONS – ENFORCEMENT**

- A. The Regional Water Board is authorized to enforce the terms of this permit under several provisions of the Water Code, including, but not limited to, sections 13268, 13385, 13386, and 13387.

## **VII. ADDITIONAL PROVISIONS—NOTIFICATION LEVELS**

### **A. Publicly-Owned Treatment Works (POTWs)**

All POTWs shall provide adequate notice to the Regional Water Board of the following (40 C.F.R. § 122.42(b)):

1. Any new introduction of pollutants into the POTW from an indirect discharger that would be subject to CWA sections 301 or 306 if it were directly discharging those pollutants (40 C.F.R. § 122.42(b)(1)); and
2. Any substantial change in the volume or character of pollutants being introduced into that POTW by a source introducing pollutants into the POTW at the time of adoption of this Order. (40 C.F.R. § 122.42(b)(2).)
3. Adequate notice shall include information on the quality and quantity of effluent introduced into the POTW as well as any anticipated impact of the change on the quantity or quality of effluent to be discharged from the POTW. (40 C.F.R. § 122.42(b)(3).)

## ATTACHMENT E – MONITORING AND REPORTING PROGRAM (MRP)

### Contents

I.	General Monitoring Provisions.....	E-2
II.	Monitoring Locations.....	E-2
III.	Influent Monitoring Requirements .....	E-3
IV.	Effluent Monitoring Requirements .....	E-3
V.	Whole Effluent Toxicity Testing Requirements .....	E-5
	A. .. Whole Effluent Acute Toxicity .....	E-5
	B. .. Whole Effluent Chronic Toxicity.....	E-6
VI.	Receiving Water Monitoring Requirements .....	E-9
VII.	Reporting Requirements .....	E-9
	A.... General Monitoring and Reporting Requirements .....	E-9
	B. .... Self-Monitoring Reports (SMRs).....	E-9
	C.... Discharge Monitoring Reports (DMRs).....	E-12
VIII.	Modifications to Attachment G .....	E-12
IX.	Bypass Requirements.....	E-14

### Tables

Table E-1.	Monitoring Locations.....	E-2
Table E-2.	Effluent Monitoring at Monitoring Location EFF-001 .....	E-3
Table E-3.	Stormwater Monitoring.....	E-4
Table E-4.	CIWQS Reporting.....	E-10
Table E-5.	Monitoring Periods .....	E-10

**ATTACHMENT E – MONITORING AND REPORTING PROGRAM (MRP)**

The Clean Water Act (§ 308) and Code of Federal Regulations (40 C.F.R. §§ 122.41[h], 122.41[j]-[l], 122.44[i], and § 122.48) requires that all NPDES permits specify monitoring and reporting requirements. Water Code sections 13267 and 13383 also authorize the Regional Water Board to establish monitoring, inspection, entry, reporting, and recordkeeping requirements. This MRP establishes monitoring, reporting, and recordkeeping requirements that implement federal and State laws and regulations.

**I. GENERAL MONITORING PROVISIONS**

- A. The Discharger shall comply with this MRP. The Executive Officer may amend this MRP pursuant to 40 C.F.R. sections 122.62, 122.63, and 124.5. If any discrepancies exist between this MRP and the “Regional Standard Provisions and Monitoring and Reporting Requirements (Supplement to Attachment D) for NPDES Wastewater Discharge Permits” (Attachment G), this MRP shall prevail.
- B. The Discharger shall conduct all monitoring in accordance with Attachment D, section III, as supplemented by Attachment G. Equivalent test methods must be more sensitive than those specified in 40 C.F.R. section 136 and must be specified in this permit.

**II. MONITORING LOCATIONS**

The Discharger shall establish the following monitoring locations to demonstrate compliance with the effluent limitations, discharge specifications, and other requirements in this Order:

**Table E-1. Monitoring Locations**

Type of Sampling Location	Monitoring Location Name	Monitoring Location Description
Recycled Water	INF-001	Located at any point in the pipe that delivers only recycled water to the facility but upstream of any wastewater treatment unit, blending point, or point of use.
Raw Water	INF-002	Located at any point in the pipe that delivers raw water to the facility but upstream of any water treatment unit, blending point, or point of use.
Treated Process Wastewater	EFF-001	At any point after full treatment and before contact with Suisun Bay.
Disinfected Sanitary Wastewater	EFF-001-D1	At any point in the Tract 1 sanitary sewer where adequate disinfection is assured.
Disinfected Sanitary Wastewater	EFF-001-D2	At any point in the Tract 2 sanitary sewer where adequate disinfection is assured.
Stormwater	EFF-003	At any point where stormwater representative of that discharged at Discharge Point 003, including all stormwater flow tributary to that outfall, is present.
Stormwater	EFF-004	At any point where stormwater representative of that discharged at Discharge Point 004, including all stormwater flow tributary to that outfall, is present.
Stormwater	EFF-005-T2NW	At any point where stormwater representative of that discharged at Discharge Point 005-T2NW, including all stormwater flow tributary to that outfall, is present.

Type of Sampling Location	Monitoring Location Name	Monitoring Location Description
Stormwater	EFF-005-T2S-A	At any point where stormwater representative of that discharged at Discharge Point 005-T2S-A, including all stormwater flow tributary to that outfall, is present.
Stormwater	EFF-005-T2S-B	At any point where stormwater representative of that discharged at Discharge Point 005-T2S-B, including all stormwater flow tributary to that outfall, is present.
Stormwater	EFF-005-T2S-C	At any point where stormwater representative of that discharged at Discharge Point 005-T2S-C, including all stormwater flow tributary to that outfall, is present.
Stormwater	EFF-005-T2SW	At any point where stormwater representative of that discharged at Discharge Point 005-T2SW, including all stormwater flow tributary to that outfall, is present.
Stormwater	EFF-005-T4NW	At any point where stormwater representative of that discharged at Discharge Point 005-T4NW, including all stormwater flow tributary to that outfall, is present.
Stormwater	EFF-005-T4SW	At any point where stormwater representative of that discharged at Discharge Point 005-T4SW, including all stormwater flow tributary to that outfall, is present.
Stormwater	EFF-006	At any point where stormwater representative of that discharged at Discharge Point 006, including all stormwater flow tributary to that outfall, is present.

### III. INFLUENT MONITORING REQUIREMENTS

Monitoring at INF-001 and INF-002 is only required if the Discharger chooses to apply for recycled water adjustments.

### IV. EFFLUENT MONITORING REQUIREMENTS

#### A. Monitoring Location EFF-001

The Discharger shall monitor plant effluent at Monitoring Location EFF-001 as follows:

**Table E-2. Effluent Monitoring at Monitoring Location EFF-001**

Parameter	Units	Sample Type	Minimum Sampling Frequency
Flow <sup>[1]</sup>	MGD	Continuous	Continuous/D
Oil and Grease <sup>[2]</sup>	mg/L	Grab, C-24	1/Week
pH <sup>[3]</sup>	standard units	Continuous	Continuous
Temperature	°C	Continuous	Continuous
Total Coliform <sup>[4]</sup>	MPN/100 mL	Grab	1/Week
Enterococci <sup>[4]</sup>	MPN/100 mL	Grab	1/Month
BOD <sub>5</sub>	mg/L, lbs/day	C-24	1/Month
TSS	mg/L, lbs/day	C-24	1/Week
COD	mg/L, lbs/day	C-24	1/Month
Sulfide	mg/L, lbs/day	Grab	1/Month
Ammonia	mg/L as N, lbs/day	C-24	1/Month
Total Chromium	lbs/day	C-24	1/Month
Hexavalent Chromium	lbs/day	Grab	1/Month
Phenolics Compounds	lbs/day	C-24	1/Month

Parameter	Units	Sample Type	Minimum Sampling Frequency
Copper	µg/L	C-24	1/Month
Cyanide	µg/L	Grab	1/Month
Dioxin-TEQ	µg/L	C-24	2/Year
Selenium	µg/L	C-24	1/Week
Lead	µg/L	C-24	1/Month
Acute Toxicity <sup>[5]</sup>	% survival	C-24	1/Week <sup>[7]</sup>
Chronic Toxicity <sup>[6]</sup>	TUc	C-24	1/Quarter
Standard Observations	---	---	Daily

Unit Abbreviations:

MGD = million gallons per day  
 mg/L = milligrams per liter  
 µg/L = micrograms per liter  
 mg/L as N = milligrams per liter as nitrogen  
 % survival = percent survival  
 TUc = chronic toxicity units, equal to 100/NOEL, where NOEL = IC<sub>25</sub>, EC<sub>25</sub>, or NOEC

Sampling Types and Frequencies:

C-24 = 24 hour composite  
 Grab = grab sample  
 Continuous = measured continuously  
 Continuous/D = measured continuously, and recorded and reported daily  
 1/Week = once per week  
 1/Month = once per month  
 1/Quarter = once per quarter  
 2/Year = twice per year

Footnotes:

- <sup>[1]</sup> Flow shall be monitored continuously and the following information shall be reported in monthly self-monitoring reports:  
 Daily average flow (MGD)  
 Monthly average flow (MGD)  
 Total monthly flow volume (MG)  
 Maximum and minimum daily average flow rates (MGD)
- <sup>[2]</sup> Each oil and grease sampling and analysis event shall be conducted in accordance with U.S. EPA Method 1664A.
- <sup>[3]</sup> If pH is monitored continuously, the minimum and maximum pH values for each day shall be reported in self-monitoring reports.
- <sup>[4]</sup> The Discharger shall monitor for total coliform organisms and enterococci at E-001-D1 and E-001-D2
- <sup>[5]</sup> Acute bioassay tests shall be performed in accordance with MRP section V.A.
- <sup>[6]</sup> Chronic bioassay tests shall be performed in accordance with MRP section V.B.
- <sup>[7]</sup> If the Discharger partially bypasses GAC units, it shall conduct acute toxicity monitoring for the duration of the bypass.

**B. Stormwater Monitoring**

The Discharger shall monitor stormwater discharges at EFF-003 through EFF-006 as summarized in the following table:

**Table E-3. Stormwater Monitoring**

Parameter	Units	Sample Type	Minimum Sampling Frequency	Outfalls
Flow	MGD	Calculation <sup>[1]</sup>	Not Applicable	All
TOC	mg/L	Grab <sup>[2]</sup>	On each occurrence <sup>[3]</sup>	All <sup>[4]</sup>
Oil and Grease	mg/L	Grab <sup>[2]</sup>	On each occurrence <sup>[3]</sup>	All <sup>[4]</sup>
pH	s.u.	Grab <sup>[2]</sup>	On each occurrence <sup>[3]</sup>	All <sup>[4]</sup>
Specific Conductance	µmhos/cm	Grab <sup>[2]</sup>	On each occurrence <sup>[3]</sup>	All <sup>[4]</sup>
TSS	mg/L	Grab <sup>[2]</sup>	On each occurrence <sup>[3]</sup>	All <sup>[4]</sup>

Parameter	Units	Sample Type	Minimum Sampling Frequency	Outfalls
Standard Observations	---	---	On each occurrence <sup>[3]</sup>	All
BOD <sub>5</sub>	mg/L	Grab <sup>[2]</sup>	Daily during storm event	<sup>[5]</sup>
COD	mg/L	Grab <sup>[2]</sup>	Daily during storm event	<sup>[5]</sup>
Phenolic Compounds	mg/L	Grab <sup>[2]</sup>	Daily during storm event	<sup>[5]</sup>
Total Chromium	µg/L	Grab <sup>[2]</sup>	Daily during storm event	<sup>[5]</sup>
Hexavalent Chromium	µg/L	Grab <sup>[2]</sup>	Daily during storm event	<sup>[5]</sup>

- <sup>[1]</sup> The monthly cumulative rainfall shall be measured, and the total volume of stormwater discharged for each month shall be calculated based on the drainage area served by each discharge point. The monthly rainfall amount and the monthly discharge volume for each discharge point shall be reported on a monthly basis.
- <sup>[2]</sup> At least one grab sample shall be collected within the first 30 minutes of significant flow during a storm event.
- <sup>[3]</sup> For E-005 and E-006 discharges, samples for chemical analysis shall be collected, during daylight storms, at least twice during the wet season.
- <sup>[4]</sup> If and when the supplemental effluent limitations in Table 10 of this Order become effective in accordance with section IV.B.2 of this Order, the monitoring frequency at the outfalls where the limitations are in effect shall be increased to daily during each storm event.
- <sup>[5]</sup> If and when effluent limitations for this pollutant in Table 10 of this Order become effective in accordance with section IV.B.2 of this Order, monitoring shall begin at the outfalls where the limitations are in effect.

## V. WHOLE EFFLUENT TOXICITY TESTING REQUIREMENTS

### A. Whole Effluent Acute Toxicity

- Compliance with the acute toxicity effluent limitations of this Order shall be evaluated by measuring survival of test organisms exposed to 96-hour continuous flow-through bioassays at Monitoring Location EFF-001.
- Test organisms shall be rainbow trout (*Onchorhynchus mykiss*). Alternatively, the Executive Officer may specify a more sensitive organism or, if testing a particular organism proves unworkable, the most sensitive organism available.
- All bioassays shall be performed according to the most up-to-date protocols in 40 C.F.R. part 136, currently *Methods for Measuring the Acute Toxicity of Effluents and Receiving Water to Freshwater and Marine Organisms*, 5<sup>th</sup> Edition (EPA-821-R-02-012).
- Effluent used for fish bioassays must be dechlorinated prior to testing. Bioassay water monitoring shall include, on a daily basis, pH, dissolved oxygen, ammonia (if toxicity is observed), temperature, hardness, and alkalinity. These results shall be reported. If final or intermediate results of an acute bioassay test indicate a violation or threatened violation (e.g., the percentage of surviving test organisms is less than 70 percent), the Discharger shall initiate a new test as soon as practical and shall investigate the cause of the mortalities and report its findings in the next self-monitoring report. The Discharger shall repeat the test until a test fish survival rate of 90 percent or greater is observed. If the control fish survival rate is less than 90 percent, the bioassay test shall be restarted with new fish and shall continue as soon as practical until an acceptable test is completed (i.e., control fish survival rate is 90 percent or greater).

## B. Whole Effluent Chronic Toxicity

### 1. Monitoring Requirements

- a. **Sampling.** The Discharger shall collect 24-hour composite effluent samples at Monitoring Location EFF-001 for critical life stage toxicity tests as indicated below. For toxicity tests requiring renewals, the Discharger shall collect 24-hour composite samples on consecutive or alternating days.
- b. **Test Species.** The test species shall be mysid shrimp (*Americamysis bahia*). The Executive Officer may change to another test species if data suggest that another test species is more sensitive to the discharge.

The Discharger shall conduct a screening chronic toxicity test as described in Appendix E-1 or as described in applicable State Water Board plan provisions that become effective after adoption of this Order, following any significant change in the nature of the effluent. If there is no significant change in the nature of the effluent, the Discharger shall conduct a screening test and submit the results with its application for permit reissuance. Upon completion of the chronic toxicity screening, the Discharger shall use the most sensitive species to conduct subsequent monitoring.

- c. **Frequency.** Chronic toxicity monitoring shall be as specified below:
  - i. The Discharger shall monitor routinely once per quarter.
  - ii. The Discharger shall accelerate monitoring to monthly after exceeding a single-sample maximum of 10 TUc. Based on the TUc results, the Executive Officer may specify a different frequency for accelerated monitoring to ensure that accelerated monitoring provides useful information.
  - iii. The Discharger shall return to routine monitoring if accelerated monitoring does not exceed the trigger in ii, above.
  - iv. If accelerated monitoring confirms consistent toxicity in excess of the trigger in ii, above, the Discharger shall continue accelerated monitoring and initiate toxicity reduction evaluation (TRE) procedures in accordance with section V.B.3, below.
  - v. The Discharger shall return to routine monitoring after implementing appropriate elements of the TRE, and either the toxicity drops below the trigger in ii, above, or, based on the TRE results, the Executive Officer determines that accelerated monitoring would no longer provide useful information.

Monitoring conducted pursuant to a TRE shall satisfy the requirements for routine and accelerated monitoring while the TRE is underway.

- d. **Methodology.** Sample collection, handling and preservation shall be in accordance with U.S. EPA protocols. In addition, bioassays shall be conducted in compliance with the most recently promulgated test methods, as shown in Appendix E-1. These are *Short-Term Methods for Estimating the Chronic Toxicity of Effluents and Receiving Waters to*



*Marine and Estuarine Organisms*, currently third edition (EPA-821-R-02-014), and *Short-term Methods for Estimating the Chronic Toxicity of Effluents and Receiving Waters to Freshwater Organisms*, currently fourth Edition (EPA-821-R-02-013). If these protocols prove unworkable, the Executive Officer and the Environmental Laboratory Accreditation Program may grant exceptions in writing upon the Discharger's request with justification. If the Discharger demonstrates that specific identifiable substances in the discharge are rapidly rendered harmless upon discharge to the receiving water, compliance with the chronic toxicity limit may be determined after test samples are adjusted to remove the influence of those substances. Written acknowledgement that the Executive Officer concurs with the Discharger's demonstration and that the adjustment will not remove the influence of other substances must be obtained prior to any such adjustment.

- e. **Dilution Series.** The Discharger shall conduct tests at 40%, 20%, 10%, 5% and 2.5%. The "%" represents percent effluent as discharged. Test sample pH may be controlled to the level of the effluent sample as received prior to being salted up.

## 2. Reporting Requirements

- a. The Discharger shall provide toxicity test results for the current reporting period in the self-monitoring report and shall include the following, at a minimum, for each test:
  - i. Sample date
  - ii. Test initiation date
  - iii. Test species
  - iv. End point values for each dilution (e.g., number of young, growth rate, percent survival)
  - v. No Observable Effect Level (NOEL) values in percent effluent. The NOEL shall equal the IC<sub>25</sub> or EC<sub>25</sub> (see MRP Appendix E-1). If the IC<sub>25</sub> or EC<sub>25</sub> cannot be statistically determined, the NOEL shall equal to the No Observable Effect Concentration (NOEC) derived using hypothesis testing. The NOEC is the maximum percent effluent concentration that causes no observable effect on test organisms based on a critical life stage toxicity test.
  - vi. IC<sub>15</sub>, IC<sub>25</sub>, IC<sub>40</sub>, and IC<sub>50</sub> values (or EC<sub>15</sub>, EC<sub>25</sub>, EC<sub>40</sub>, and EC<sub>50</sub>) as percent effluent
  - vii. TUC values (100/NOEL, where NOEL = IC<sub>25</sub>, EC<sub>25</sub>, or NOEC)
  - viii. Mean percent mortality ( $\pm$ s.d.) after 96 hours in 100% effluent (if applicable)
  - ix. IC<sub>50</sub> or EC<sub>50</sub> values for reference toxicant tests
  - x. Available water quality measurements for each test (e.g., pH, dissolved oxygen, temperature, conductivity, hardness, salinity, and ammonia)

### 3. Toxicity Reduction Evaluation (TRE)

- a. The Discharger shall prepare a generic TRE work plan within 90 days of the effective date of this Order to be ready to respond to toxicity events. The Discharger shall review and update the work plan as necessary so that it remains current and applicable to the discharge and discharge facilities.
- b. Within 30 days of exceeding the chronic toxicity trigger in section V.B.1.c.ii, above, the Discharger shall submit a TRE work plan, which shall be the generic work plan revised as appropriate for this toxicity event after consideration of available discharge data.
- c. Within 30 days of completing an accelerated monitoring test observed to exceed the trigger in section V.B.1.c.ii, above, the Discharger shall initiate a TRE in accordance with a TRE work plan that incorporates any and all comments from the Executive Officer.
- d. The TRE shall be specific to the discharge and be in accordance with current technical guidance and reference materials, including U.S. EPA guidance materials. The Discharger shall conduct the TRE as a tiered evaluation as summarized below:
  - i. Tier 1 shall consist of basic data collection (routine and accelerated monitoring).
  - ii. Tier 2 shall consist of evaluation of treatment process optimization, including operational practices and in-plant process chemicals.
  - iii. Tier 3 shall consist of a toxicity identification evaluation (TIE).
  - iv. Tier 4 shall consist of evaluation of options for additional effluent treatment processes.
  - v. Tier 5 shall consist of evaluation of options for modifications of in-plant treatment processes.
  - vi. Tier 6 shall consist of implementation of selected toxicity control measures, and follow-up monitoring and confirmation of implementation success.
- e. The Discharger may end the TRE at any stage if monitoring finds there is no longer consistent toxicity (i.e., compliance with Effluent Limitation IV.A.6 of the Order).
- f. The objective of the TIE shall be to identify the substance or combination of substances causing the observed toxicity. The Discharger shall employ all reasonable efforts using currently available TIE methodologies.
- g. As toxic substances are identified or characterized, the Discharger shall continue the TRE by determining the sources and evaluating alternative strategies for reducing or eliminating the toxic substances from the discharge. The Discharger shall take all reasonable steps to reduce toxicity to levels below the chronic toxicity limit.
- h. Many recommended TRE elements parallel required or recommended efforts related to source control, pollution prevention, and stormwater control programs. TRE efforts

should be coordinated with such efforts. To prevent duplication of efforts, evidence of complying with requirements or recommended efforts of such programs may be acceptable to demonstrate compliance with TRE requirements.

- i. Chronic toxicity may be episodic and identification of causes of and reduction of sources of chronic toxicity may not be successful. Regional Water Board enforcement considerations will be based in part on the Discharger's actions and efforts to identify and control or reduce sources of consistent toxicity.

## VI. RECEIVING WATER MONITORING REQUIREMENTS

The Discharger shall continue to participate in the Regional Monitoring Program, which collects data on pollutants and toxicity in San Francisco Bay water, sediment, and biota.

## VII. REPORTING REQUIREMENTS

### A. General Monitoring and Reporting Requirements

The Discharger shall comply with all Standard Provisions (Attachments D and G) related to monitoring, reporting, and recordkeeping, with modifications shown in section VIII, below.

### B. Self-Monitoring Reports (SMRs)

1. **SMR Format.** The Discharger shall electronically submit SMRs using the State Water Board's California Integrated Water Quality System (CIWQS) Web site (<http://www.waterboards.ca.gov/ciwqs/index.html>). The CIWQS website will provide additional information for SMR submittal in the event of a planned service interruption for electronic submittal.
2. **SMR Due Dates and Contents.** The Discharger shall submit SMRs by the due dates, and with the contents, specified below:
  - a. **Monthly SMRs** — Monthly SMRs shall be due 30 days after the end of each calendar month, covering that calendar month. The monthly SMR shall contain the applicable items described in sections V.B and V.C of both Attachments D and G of this Order. See Provision VI.C.2 (Effluent Characterization Study and Report) of this Order for information that must also be reported with monthly SMRs.

Monthly SMRs shall include all new monitoring results obtained since the last SMR was submitted. If the Discharger monitors any pollutant more frequently than required by this Order, the Discharger shall include the results of such monitoring in the calculations and reporting for the SMR.

- b. **Annual SMR** — Annual SMRs shall be due February 1 each year, covering the previous calendar year. The annual SMR shall contain the items described in sections V.C.1.f of Attachment G. See also Provision VI.C.2 (Effluent Characterization Study and Report) of the Order for requirements to submit reports with the annual SMR.
3. **Specifications for Submitting SMRs to CIWQS** — The Discharger shall submit analytical results and other information using one of the following methods:

**Table E-4. CIWQS Reporting**

Parameter	Method of Reporting	
	EDF/CDF data upload or manual entry	Attached File
All parameters identified in influent, effluent, and receiving water monitoring tables (except Dissolved Oxygen and Temperature)	Required for all results	
Dissolved Oxygen Temperature	Required for monthly maximum and minimum results only <sup>[1]</sup>	Discharger may use this method for all results or keep records
Cyanide Arsenic Cadmium Chromium Copper Lead Mercury Nickel Selenium Silver Zinc Dioxins & Furans (by U.S. EPA Method 1613) Antimony Beryllium Thallium Other Pollutants (by U.S. EPA methods 601, 602, 608, 610, 614, 624, and 625)	Required for all results <sup>[2]</sup>	
Analytical Method	Not required (Discharger may select “data unavailable”) <sup>[1]</sup>	
Collection Time Analysis Time	Not required (Discharger may select “0:00”) <sup>[1]</sup>	

Footnotes for Table E-4:

- <sup>[1]</sup> The Discharger shall continue to monitor at the minimum frequency specified in this MRP, keep records of the measurements, and make the records available upon request.
- <sup>[2]</sup> These parameters require EDF/CDF data upload or manual entry regardless of whether monitoring is required by this MRP or other provisions of this Order (except for biosolids, sludge, or ash provisions).

The Discharger shall arrange all reported data in a tabular format and summarize data to clearly illustrate whether the Facility is operating in compliance with effluent limitations. The Discharger is not required to duplicate the submittal of data entered in a tabular format within CIWQS. When electronic submittal of data is required and CIWQS does not provide for entry into a tabular format, the Discharger shall electronically submit the data in a tabular format as an attachment.

**4. Monitoring Periods.** Monitoring periods for all required monitoring shall be as set forth below unless otherwise specified:

**Table E-5. Monitoring Periods**

Sampling Frequency	Monitoring Period Begins On...	Monitoring Period
Continuous	Order effective date	All times
1/ Hour	Order effective date	Every two-hour period, beginning at midnight (e.g., 12:00 a.m. through 1:59 a.m.)

Sampling Frequency	Monitoring Period Begins On...	Monitoring Period
1/Week or 2/Week	Sunday following Order effective date or on Order effective date if on Sunday	Sunday through Saturday
1/Month	First day of calendar month following Order effective date or on Order effective date if on first day of month	First day of calendar month through last day of calendar month
1/Quarter	Closest January 1, April 1, July 1, or October 1 following (or on) Order effective date	January 1 through March 31 April 1 through June 30 July 1 through September 30 October 1 through December 31
2/Year	Closest January 1 or July 1 before or after Order effective date	January 1 through June 30 July 1 through December 31
1/Year	Closest January 1 before or after Order effective date	January 1 through December 31

**5. RL and MDL Reporting.** The Discharger shall report with each sample result the Reporting Level (RL) and Method Detection Limit (MDL) as determined by the procedure in 40 C.F.R. part 136. The Discharger shall report the results of analytical determinations for the presence of chemical constituents in a sample using the following reporting protocols:

- a. Sample results greater than or equal to the RL shall be reported as measured by the laboratory (i.e., the measured chemical concentration in the sample).
- b. Sample results less than the RL, but greater than or equal to the laboratory’s MDL, shall be reported as “Detected, but Not Quantified,” or DNQ. The estimated chemical concentration of the sample shall also be reported.

For purposes of data collection, the laboratory shall write the estimated chemical concentration next to DNQ. The laboratory may, if such information is available, include numerical estimates of the data quality for the reported result. Numerical estimates of data quality may be percent accuracy (+/- a percentage of the reported value), numerical ranges (low to high), or any other means the laboratory considers appropriate.

- c. Sample results less than the laboratory’s MDL shall be reported as “Not Detected”, or ND.
- d. The Discharger shall instruct laboratories to establish calibration standards so that the minimum level (ML) value (or its equivalent if there is differential treatment of samples relative to calibration standards) is the lowest calibration standard. At no time is the Discharger to use analytical data derived from extrapolation beyond the lowest point of the calibration curve.

**6. Compliance Determination.** Compliance with effluent limitations for priority pollutants shall be determined using sample reporting protocols defined above and in the Fact Sheet and Attachments A, D, and G. For purposes of reporting and administrative enforcement by the Regional Water Board and State Water Board, the Discharger shall be deemed out of compliance with effluent limitations if the concentration of the priority pollutant in the monitoring sample is greater than the effluent limitation and greater than or equal to the reporting level (RL).

### C. Discharge Monitoring Reports (DMRs)

1. The Discharge shall electronically submit DMRs via CIWQS as directed by the State Water Board.

## VIII. MODIFICATIONS TO ATTACHMENT G

This MRP modifies Attachment G as indicated below:

### A. Attachment G section V.C.1.c.2 is revised as follows:

- 2) When determining compliance with an average monthly or maximum daily effluent limitation, and more than one sample result is available, the Discharger shall compute the arithmetic mean unless the data set contains one or more reported determinations of detected but not quantified (DNQ) or nondetect (ND). In those cases, the Discharger shall compute the median in place of the arithmetic mean in accordance with the following procedure:
  - i. The data set shall be ranked from low to high, reported ND determinations lowest, DNQ determinations next, followed by quantified values (if any). The order of the individual ND or DNQ determinations is unimportant.
  - ii. The median value of the data set shall be determined. If the data set has an odd number of data points, then the median is the middle value. If the data set has an even number of data points, then the median is the average of the two values around the middle unless one or both of the points are ND or DNQ, in which case the median value shall be the lower of the two data points where DNQ is lower than a value and ND is lower than DNQ.

If a sample result, or the arithmetic mean or median of multiple sample results, is below the reporting limit, and there is evidence that the priority pollutant is present in the effluent above an effluent limitation and the Discharger conducts a Pollutant Minimization Program, the Discharger shall not be deemed out of compliance.

### B. Attachment G sections V.C.1.f and V.C.1.g are revised as follows, and section V.C.1.h (Reporting data in electronic format) is deleted:

- f. Annual self-monitoring report requirements

By the date specified in the MRP, the Discharger shall submit an annual report to the Regional Water Board covering the previous calendar year. The report shall contain the following:

- 1) Annual compliance summary table of treatment plant performance, including documentation of any blending events (this summary table is not required if the Discharger has submitted the year's monitoring results to CIWQS in electronic reporting format by EDF/CDF upload or manual entry);
- 2) Comprehensive discussion of treatment plant performance and compliance with the permit (This discussion shall include any corrective actions taken or planned, such as changes to facility equipment or operation practices that may be needed to

achieve compliance, and any other actions taken or planned that are intended to improve performance and reliability of the Discharger's wastewater collection, treatment, or disposal practices.);

- 3) Both tabular and graphical summaries of the monitoring data for the previous year if parameters are monitored at a frequency of monthly or greater (this item is not required if the Discharger has submitted the year's monitoring results to CIWQS in electronic reporting format by EDF/CDF upload or manual entry);
  - 4) List of approved analyses, including the following:
    - (i) List of analyses for which the Discharger is certified;
    - (ii) List of analyses performed for the Discharger by a separate certified laboratory (copies of reports signed by the laboratory director of that laboratory shall not be submitted but be retained onsite); and
    - (iii) List of "waived" analyses, as approved;
  - 5) Plan view drawing or map showing the Discharger's facility, flow routing, and sampling and observation station locations;
  - 6) Results of annual facility inspection to verify that all elements of the SWPP Plan are accurate and up to date (only required if the Discharger does not route all stormwater to the headworks of its wastewater treatment plant); and
  - 7) Results of facility report reviews (The Discharger shall regularly review, revise, and update, as necessary, the O&M Manual, the Contingency Plan, the Spill Prevention Plan, and Wastewater Facilities Status Report so that these documents remain useful and relevant to current practices. At a minimum, reviews shall be conducted annually. The Discharger shall include, in each Annual Report, a description or summary of review and evaluation procedures, recommended or planned actions, and an estimated time schedule for implementing these actions. The Discharger shall complete changes to these documents to ensure they are up-to-date.).
- g. Report submittal
- The Discharger shall submit SMRs addressed as follows, unless the Discharger submits SMRs electronically to CIWQS:
- California Regional Water Quality Control Board  
San Francisco Bay Region  
1515 Clay Street, Suite 1400  
Oakland, CA 94612  
Attn: NPDES Wastewater Division
- h. Reporting data in electronic format – *Deleted*

## **IX. BYPASS REQUIREMENTS**

If the Discharger bypasses any of its treatment units under the conditions stated in I.G.2 of Attachment D, it shall monitor flows and collect samples on a daily basis for all constituents at affected discharge points that have effluent limits (except chronic toxicity) for the duration of the bypass (including acute toxicity using static renewals). As such discharges may result in noncompliance that may endanger health or the environment, the Discharger shall follow the reporting requirements under V.E.1 of Attachment D.



**APPENDIX E-1  
CHRONIC TOXICITY  
DEFINITION OF TERMS AND SCREENING PHASE REQUIREMENTS**

**I. Definition of Terms**

- A. No observed effect level (NOEL) for compliance determination is equal to IC<sub>25</sub> or EC<sub>25</sub>. If the IC<sub>25</sub> or EC<sub>25</sub> cannot be statistically determined, the NOEL shall be equal to the NOEC derived using hypothesis testing.
- B. Effective concentration (EC) is a point estimate of the toxicant concentration that would cause an adverse effect on a quantal, “all or nothing,” response (such as death, immobilization, or serious incapacitation) in a given percent of the test organisms. If the effect is death or immobility, the term lethal concentration (LC) may be used. EC values may be calculated using point estimation techniques such as probit, logit, and Spearman-Kärber. EC<sub>25</sub> is the concentration of toxicant (in percent effluent) that causes a response in 25 percent of the test organisms.
- C. Inhibition concentration (IC) is a point estimate of the toxicant concentration that would cause a given percent reduction in a nonlethal, nonquantal biological measurement, such as growth. For example, an IC<sub>25</sub> is the estimated concentration of toxicant that would cause a 25 percent reduction in average young per female or growth. IC values may be calculated using a linear interpolation method such as U.S. EPA's Bootstrap Procedure.
- D. No observed effect concentration (NOEC) is the highest tested concentration of an effluent or a toxicant at which no adverse effects are observed on the aquatic test organisms at a specific time of observation. It is determined using hypothesis testing.

**II. Chronic Toxicity Screening Phase Requirements**

- A. The Discharger shall perform screening phase monitoring:
  - 1. Subsequent to any significant change in the nature of the effluent discharged through changes in sources or treatment, except those changes resulting from reductions in pollutant concentrations attributable to source control efforts, or
  - 2. Prior to permit reissuance. Screening phase monitoring data shall be included in the NPDES permit application for reissuance. The information shall be as recent as possible, but may be based on screening phase monitoring conducted within 5 years before the permit expiration date.
- B. Design of the screening phase shall, at a minimum, consist of the following elements:
  - 1. Use of test species specified in Appendix E-2, attached, and use of the protocols referenced in those tables.

2. Two stages:
    - a. Stage 1 shall consist of a minimum of one battery of tests conducted concurrently. Selection of the type of test species and minimum number of tests shall be based on Appendix E-2 (attached).
    - b. Stage 2 shall consist of a minimum of two test batteries conducted at a monthly frequency using the three most sensitive species based on the Stage 1 test results.
  3. Appropriate controls.
  4. Concurrent reference toxicant tests.
  5. Dilution series of 100%, 50%, 25%, 12.5%, 6.25%, and 0%, where “%” is percent effluent as discharged, or as otherwise approved by the Executive Officer if different dilution ratios are needed to reflect discharge conditions.
- C. The Discharger shall submit a screening phase proposal. The proposal shall address each of the elements listed above. If within 30 days, the Executive Officer does not comment, the Discharger shall commence with screening phase monitoring.

## APPENDIX E-2 SUMMARY OF TOXICITY TEST SPECIES REQUIREMENTS

**Table AE-1. Critical Life Stage Toxicity Tests for Estuarine Waters**

Species	(Scientific Name)	Effect	Test Duration	Reference
Alga	<i>(Skeletonema costatum)</i> <i>(Thalassiosira pseudonana)</i>	Growth rate	4 days	1
Red alga	<i>(Champia parvula)</i>	Number of cystocarps	7–9 days	3
Giant kelp	<i>(Macrocystis pyrifera)</i>	Percent germination; germ tube length	48 hours	2
Abalone	<i>(Haliotis rufescens)</i>	Abnormal shell development	48 hours	2
Oyster Mussel	<i>(Crassostrea gigas)</i> <i>(Mytilus edulis)</i>	Abnormal shell development; percent survival	48 hours	2
Echinoderms - Urchins Sand dollar	<i>(Strongylocentrotus purpuratus, S. franciscanus)</i> <i>(Dendraster excentricus)</i>	Percent fertilization or larval development	1 hour or 72 hours	2
Shrimp	<i>(Americamysis bahia)</i>	Percent survival; growth	7 days	3
Shrimp	<i>(Holmesimysis costata)</i>	Percent survival; growth	7 days	2
Topsmelt	<i>(Atherinops affinis)</i>	Percent survival; growth	7 days	2
Silversides	<i>(Menidia beryllina)</i>	Larval growth rate; percent survival	7 days	3

**Toxicity Test References:**

1. American Society for Testing Materials (ASTM). 1990. Standard Guide for Conducting Static 96-Hour Toxicity Tests with Microalgae. Procedure E 1218-90. ASTM, Philadelphia, PA.
2. Short-term Methods for Estimating the Chronic Toxicity of Effluent and Receiving Waters to West Coast Marine and Estuarine Organisms. EPA/600/R-95/136. August 1995.
3. Short-term Methods for Estimating the Chronic Toxicity of Effluent and Receiving Waters to Marine and Estuarine Organisms. EPA/821/R-02/014. October 2002.

**Table AE-2. Critical Life Stage Toxicity Tests for Fresh Waters**

Species	(Scientific Name)	Effect	Test Duration	Reference
Fathead minnow	<i>(Pimephales promelas)</i>	Survival; growth rate	7 days	4
Water flea	<i>(Ceriodaphnia dubia)</i>	Survival; number of young	7 days	4
Alga	<i>(Selenastrum capricornutum)</i>	Final cell density	4 days	4

**Toxicity Test Reference:**

1. Short-term Methods for Estimating the Chronic Toxicity of Effluents and Receiving Waters to Freshwater Organisms, fourth Edition Chronic manual (EPA-821-R-02-013, October 2002).

**Table AE-3. Toxicity Test Requirements for Stage One Screening Phase**

Requirements	Receiving Water Characteristics		
	Discharges to Coast	Discharges to San Francisco Bay <sup>[1]</sup>	
		Ocean	Marine/Estuarine
Taxonomic diversity	1 plant 1 invertebrate 1 fish	1 plant 1 invertebrate 1 fish	1 plant 1 invertebrate 1 fish
Number of tests of each salinity type: Freshwater <sup>[2]</sup>	0	1 or 2	3
Marine/Estuarine	4	3 or 4	0
Total number of tests	4	5	3

**Footnotes:**

- <sup>[1]</sup> (a) Marine refers to receiving water salinities greater than 1 part per thousand (ppt) at least 95 percent of the time during a normal water year.  
 (b) Freshwater refers to receiving water with salinities less than 1 ppt at least 95 percent of the time during a normal water year.  
 (c) Estuarine refers to receiving water salinities that fall between those of marine and freshwater, as described above.
- <sup>[2]</sup> The freshwater species may be substituted with marine species if:
  - (a) The salinity of the effluent is above 1 ppt greater than 95 percent of the time, or
  - (b) The ionic strength (TDS or conductivity) of the effluent at the test concentration used to determine compliance is documented to be toxic to the test species.

## ATTACHMENT F - FACT SHEET

### Contents

I.	Permit Information.....	F-3
II.	Facility Description.....	F-4
	A.... Wastewater and Biosolids Treatment.....	F-4
	B.... Discharge Point and Receiving Waters .....	F-5
	C.... Summary of Existing Requirements and Monitoring Data .....	F-7
	D.... Compliance Summary .....	F-9
	E.... Planned Changes .....	F-9
III.	Applicable Plans, Policies, and Regulations.....	F-9
IV.	Rationale For Effluent Limitations and Discharge Specifications .....	F-12
	A.... Discharge Prohibitions .....	F-12
	B.... Conventional and Non-Conventional Pollutant Effluent Limitations .....	F-12
	1. Scope and Authority .....	F-12
	2. Technology-Based Effluent Limitations .....	F-13
	C.... Toxic Pollutant Effluent Limitations.....	F-14
	1. Scope and Authority .....	F-14
	2. Beneficial Uses and Water Quality Criteria and Objectives .....	F-14
	3. Need for Water Quality-Based Effluent Limitations (Reasonable Potential Analysis) .....	F-16
	4. Water Quality-Based Effluent Limitations (WQBELs) .....	F-20
	5. Bacteria .....	F-28
	6. Selenium Mass limit .....	F-29
	7. Whole Effluent Acute Toxicity .....	F-30
	8. Whole Effluent Chronic Toxicity .....	F-30
	D.... Effluent Limitation Considerations .....	F-31
V.	Rationale for Receiving Water Limitations .....	F-32
VI.	Rationale for Provisions.....	F-32
	A.... Standard Provisions.....	F-32
	B.... Monitoring and Reporting .....	F-33
	C.... Special Provisions .....	F-33
	1. Reopener Provisions .....	F-33
	2. Effluent Characterization Study and Report .....	F-33
	3. Pollutant Minimization Program .....	F-33
	4. Other Special Provisions .....	F-33
VII.	Rationale for Monitoring and reporting program (MRP).....	F-34
VIII.	Public Participation .....	F-35

### Tables

Table F-1.	Facility Information.....	F-3
Table F-2.	Outfall Locations .....	F-6
Table F-3a.	Summary of Previous Technology-Based Effluent Limitations and Monitoring Data, Discharge Point, 001 .....	F-7
Table F-3b.	Summary of Previous Water Quality-Based Effluent Limitations and Monitoring Data, Discharge Point 001 .....	F-7
Table F-4.	Previous Stormwater Effluent Limitations.....	F-8

Table F-5. Stormwater Quality .....F-8  
Table F-6. Beneficial Uses .....F-10  
Table F-7. Reasonable Potential Analysis .....F-17  
Table F-8. WQBEL Calculations .....F-23

## ATTACHMENT F – FACT SHEET

This Fact Sheet includes the legal requirements and technical rationale that serve as the basis for the requirements of this Order. As described in section II.B of the Order, the Regional Water Board incorporates this Fact Sheet as findings supporting the issuance of the Order.

### I. PERMIT INFORMATION

The following table summarizes administrative information related to the facility:

**Table F-1. Facility Information**

<b>WDID</b>	2 071048001
<b>CIWQS Place ID</b>	228968
<b>Discharger</b>	Tesoro Refining and Marketing Company
<b>Facility Name</b>	Tesoro Martinez Refinery
<b>Facility Address</b>	150 Solano Way Martinez, CA 94553 Contra Costa County
<b>Facility Contact, Title, Phone</b>	Peter Carroll, Environmental Engineer, 925-335-3497
<b>Authorized Person to Sign and Submit Reports</b>	Matthew Buell, Environmental Manager, 925-370-3275
<b>Mailing Address</b>	150 Solano Way, Martinez, CA 94553
<b>Billing Address</b>	Same as Mailing Address
<b>Facility Type</b>	Petroleum Refinery
<b>Major or Minor Facility</b>	Major
<b>Threat to Water Quality</b>	1
<b>Complexity</b>	A
<b>Pretreatment Program</b>	N/A
<b>Reclamation Requirements</b>	No
<b>Mercury and PCBs Requirements</b>	NPDES Permit No. CA0038849
<b>Hydraulic Capacity</b>	10.44 million gallons per day (MGD)
<b>Average Facility Flow (2011-2014)</b>	4.4 MGD
<b>Watershed</b>	Suisun Bay
<b>Receiving Water</b>	Suisun Bay
<b>Receiving Water Type</b>	Estuarine

- A. The Tesoro Refining and Marketing Company (hereinafter Discharger) is the owner and operator of the Tesoro Martinez Refinery (Facility). For the purposes of this Order, references to the “discharger” or “permittee” in applicable federal and State laws, regulations, plans, or policy are held to be equivalent to references to the Discharger herein.
- B. The Discharger is regulated pursuant to National Pollutant Discharge Elimination System (NPDES) Permit No. CA0004961. The Discharger was previously subject to the NPDES permit in Order No. R2-2010-0084 (previous order), which was adopted on June 9, 2010, and was administratively extended as allowed by law past its expiration date (June 30, 2015). The Facility discharges treated wastewater and stormwater to Suisun Bay, a water of the United States. Attachment B provides maps of the area around the Facility. Attachment C provides a wastewater treatment flow schematic.

- C. The Discharger filed a Report of Waste Discharge and submitted an application for reissuance of its Waste Discharge Requirements (WDRs) and NPDES permit on December 30, 2014.
- D. The discharge is also regulated under NPDES Permit No. CA0038849, which establishes requirements on mercury and polychlorinated biphenyls (PCBs) from wastewater discharges to San Francisco Bay. This Order does not affect that permit.

## II. FACILITY DESCRIPTION

### A. Wastewater and Biosolids Treatment

The Discharger owns and operates a petroleum refinery that processes a crude oil volume of approximately 143,600 barrels per day (bbls/d). The Discharger receives crude oil by tanker or pipelines for the production of unleaded gasoline and diesel fuels. According to 40 CFR Part 419.20, U.S. EPA has classified this facility as a cracking refinery. The average discharge rate from March 2011 through July 2014 was 4.4 MGD; the hydraulic capacity of the treatment plant is approximately 10.44 MGD.

The refinery's wastewater treatment plant treats wastewater from sour water strippers, the ammonia recovery unit, acid plant effluent, cooling tower blowdown, boiler blowdown, cooling tower and boiler blowdown from the Foster Wheeler Cogeneration Plant, neutralized demineralizer regeneration water (hereinafter the Reject Water) from the water treatment system, the fire water system, groundwater from remediation activities; non-hazardous wastewater generated from offsite Discharger-owned facilities, the MECS Catalyst Plant, and cooling tower and boiler blowdown from the Air Liquide Carbon Dioxide Plant. Additionally, the wastewater treatment plant also treats sanitary wastewater and stormwater from about 710 acres of process areas.

The Discharger routes process wastewater to a central pump station (i.e., No. 1 pump station). From this pump station, process wastewater flows to an API oily-water and solids separator that consists of a head channel that feeds four concrete channels. The API separator uses a chain driven system to remove oil and solids. The Discharger pumps this material to Tanks 699 and 700 for additional oil and water separation and recovery. After the API separator, wastewater flows by gravity to four dissolved nitrogen flotation (DNF) units where additional oil and solids are removed.

From the DNF units, wastewater is routed through an air stripper where a blower forces air through a grid of perforated tubes. The vapors from the air stripper, DNF units, and API separator are incinerated in a thermal oxidizer. The Discharger pumps wastewater from the air stripper to Surge Pond No. 1 for biotreatment. Surge Pond No. 1 is a 14-acre rectangular basin that is baffled into four cells where aeration and nutrients are provided. From Surge Pond No. 1, wastewater flows by gravity to Surge Pond No. 2. Surge Pond No. 2 is a 6-acre rectangular basin that is also aerated. The Discharger may pump up to 900 gallons per minute of wastewater from Surge Pond No. 2 to the refinery for reuse as industrial water. The remaining wastewater from Surge Pond No. 2 is pumped to the Bio-Oxidation Pond (Ox Pond). The Ox Pond is about 108 acres with an estimated capacity of 216 million gallons but typically operates with a volume of around 150 million gallons. The Ox Pond is aerated at the inlet section of the pond. It passively treats wastewater by providing retention time of about 30 days.



From the Ox Pond, the Discharger routes wastewater to two clarifiers that operate in parallel. In the clarifiers, the Discharger adds coagulants and flocculants to enhance settling of wastewater solids. Clarifier solids are centrifuged and disposed of offsite. The supernatant from the centrifuge is routed to Surge Pond No. 1. From the clarifiers, wastewater flows through a toothed weir to two filters (Round and Zimpro) that operate in parallel. The Round filter is multimedia (sand and anthracite) and consists of six chambers, while the Zimpro filter is a six-celled trickling sand filter. Both of these filters contain automatic backwash functions that allow them to maintain continuous operation. Backwash water from the filters is routed to Surge Pond No. 1 for treatment, and treated wastewater is routed to twelve granular activated carbon (GAC) columns that operate in pairs (i.e., lead and lag). The Discharger uses GAC columns to ensure treated wastewater is not toxic to aquatic life. The GAC columns may be partially bypassed when toxicity levels are low to increase flow through the wastewater treatment plant. This Order allows this to occur during the wet season to increase outflow from the Ox Pond. Backwash water from the GAC columns is also discharged to Surge Pond No. 1 for further treatment.

After the GAC columns, the Discharger normally routes wastewater to the Clean Canal. The Clean Canal also receives stormwater runoff and neutralized demineralizer reject water from the Discharger's raw water treatment plant. The Clean Canal conveys treated wastewater and the other streams to a sump containing three pumps that discharge to Suisun Bay under the Avon Wharf.

The refinery also has several stormwater discharge points; however, most of the stormwater at the refinery is routed to the refinery's wastewater treatment plant for treatment and discharge via Discharge Point 001.

## **B. Discharge Point and Receiving Waters**

Treated wastewater from the Clean Canal is discharged to Suisun Bay through a deepwater outfall (Discharge Point 001) through a 27-inch diameter outfall. The outfall terminates with a multi-port diffuser located under the Avon Wharf. The diffuser consists of six ports, each 8 inches in diameter, located approximately 8 feet above the Suisun Bay floor, and 48 feet below mean lower low water. The diffuser ports are spaced between 2 feet and 4 feet 4 inches. Additionally, the diffuser ports are at angles with respect to the main pipe that range from  $-65^{\circ}$  to  $65^{\circ}$ .

The locations of the Tesoro Martinez Refinery Discharge Point 001 and stormwater Discharge Points 003 – 006, and the corresponding receiving water, are shown in Table F-2 below.

**Table F-2. Outfall Locations**

Discharge Point	Effluent Description	Discharge Point Latitude	Discharge Point Longitude	Receiving Water
001	Treated refinery process wastewater and stormwater	38.0483	-122.0894	Suisun Bay
003	Stormwater from about 76 acres in the southwestern portion of the Tract 4 tank farm.	38.0122	-122.0652	Walnut Creek
004	Stormwater from about 198 acres, including the southeast portion of the Tract 4 tank farm and all of the Tract 6 tank farm and offsite facilities.	38.0225	-122.0583	Hastings Slough
005-T2NW	Stormwater from small areas near a stairway leading down to a non-operating saltwater pump station on the creek side of the slope.	38.0302	-122.0753	Walnut Creek
005-T2S-A	Stormwater from small areas near the channel drain along the north side of a fence at a used equipment reclamation area before Gate 15 south of the Foster Wheeler area.	38.0191	-122.0669	Walnut Creek
005-T2S-B	Stormwater from small areas near the fence line immediately north of the railroad tracks. This area is at the extreme south end of Tract 2.	38.0193	-122.0674	Walnut Creek
005-T2S-C	Stormwater from small areas across the road west of the Foster Wheeler yard (three tall gray tanks) where runoff from the asphalt perimeter drainage channels run under the road towards the creek.	38.0202	-122.0683	Walnut Creek
005-T2SW	Stormwater from small areas near the "D" Street firehouse, against the fence. This area includes paved areas around the auto shop and the western side of the Purchasing and Storehouse.	38.0223	-122.0693	Walnut Creek
005-T4NW	Stormwater from small areas at the easternmost culvert that conveys runoff from this area under the road to the west.	38.0179	-122.0675	Walnut Creek
005-T4SW	Stormwater from small areas near the outlet of the pipe that drains the impoundment. The pipe has a locked valve on it and is required to be sampled when there is a discharge from the impoundment.	38.0055	-122.0587	Walnut Creek
006	Waste Management Unit (WMU) 5 Cap Runoff	38.0274	-122.0567	Hastings Slough

### C. Summary of Existing Requirements and Monitoring Data

Effluent limitations in the previous permit and representative monitoring data for Discharge Point 001 are summarized below:

**Table F-3a. Summary of Previous Technology-Based Effluent Limitations and Monitoring Data, Discharge Point, 001**

Parameter	(units)	Effluent Limitations		Monitoring Data (From 3/11 To 12/14)	
		Monthly Average	Daily Maximum	Highest Monthly Average	Highest Daily Discharge
BOD <sub>5</sub>	lb/day	2,300	4,200	2,025	2,025
COD	lb/day	16,000	31,000	8,302	8,302
TSS	lb/day	1,800	2,900	804	1,413
Oil and Grease	lb/day	670	1,300	205	278
Phenolic Compounds	lb/day	13	31	2.8	2.8
Ammonia as N	lb/day	1,300	2,800	699	821
Sulfide	lb/day	12	27	<9.3	<9.3
Total Chromium	lb/day	15	42	0.26	0.26
Hexavalent Chromium	lb/day	1.2	2.7	<0.93	<1.93
pH	standard units	Between 6.0 and 9.0		6.03 – 8.92 <sup>[1]</sup>	
Total Coliform Organisms <sup>[2]</sup>	MPN/100 mL	Not greater than 240 (5-Sample Median)		<1	
		Not greater than 10,000 (Single-Sample)		24,000	

Notes :

BOD<sub>5</sub> = 5-day Biochemical Oxygen Demand  
 COD = Chemical Oxygen Demand  
 TSS = Total Suspended Solids

<sup>[1]</sup> Range from lowest to highest.

<sup>[2]</sup> Total Coliform samples are collected at any point where adequate disinfection is assured. The sampling points are upstream of the Ox Pond.

**Table F-3b. Summary of Previous Water Quality-Based Effluent Limitations and Monitoring Data, Discharge Point 001**

Parameter	Units	Final Limits		Monitoring Data (From 03/11 To 12/14)	
		Monthly Average	Daily Maximum	Highest Monthly Average	Highest Daily Value
Copper	µg/L	13	24	3.7	24
Selenium	µg/L	41	50	34	49
Cyanide	µg/L	21	42	12	12
Lead	µg/L	3.7	7.8	2.9	2.9
Dioxin-TEQ	µg/L	1.4 x 10 <sup>-8</sup>	2.8 x 10 <sup>-8</sup>	2.85 x 10 <sup>-10</sup>	2.85 x 10 <sup>-10</sup>
Ammonia (N)	mg/L	26	67	16	24
Acute Toxicity	% Survival	Not less than 90% (11-Sample Median)		95 <sup>[1]</sup>	
		Not less than 70% (11-Sample 90 <sup>th</sup> Percentile)		85 <sup>[1]</sup>	
Chronic Toxicity	TU <sub>c</sub>	Not greater than 10 (3-Sample Median)		1.2	
		Not greater than 20 (Single-Sample)		2.3	

<sup>[1]</sup> Minimum survival rate.

The previous order (section B.1) established the following effluent limitations, based on the requirements of *Effluent Limitations Guidelines for the Petroleum Refining Point Source Category*, for discharges of stormwater through Discharge Points 003 – 006:

**Table F-4. Previous Stormwater Effluent Limitations**

Pollutant	Limitation
pH	within 6.5 to 8.5
Oil & Grease	daily maximum of 15 mg/L
TOC	daily maximum of 110 mg/L

In its Report of Waste Discharge (March 2011 through December 2014), the Discharger provided the following characterization of its stormwater discharges through Discharge Points 003 – 006:

**Table F-5. Stormwater Quality**

Discharge Point	Oil & Grease (mg/L)		TOC (mg/L)		TSS (mg/L)	
	Average	Daily Maximum	Average	Daily Maximum	Average	Daily Maximum
003	< 1.4	< 1.4	10	10	74	74
004	< 1.4	2.2	11	14	28	146
005-T2NW	< 1.4	3.3	14	28	132	604
005-T2S-A	< 1.4	< 5	6.8	13	41	89
005-T2S-B	3.6 <sup>[1]</sup>	6.3	12	23	448	1770
005-T2S-C	< 5	< 5	6.7	20	48	84
005-T2SW	< 5	1.6	7.9	18	39	115
005-T4NW	< 5	2.5	9.7	15	854	2660
005-T4SW	No data available.					
006	< 5	1.4	1.7 <sup>[2]</sup>	4.1	46	150

Notes:

TOC = Total Organic Carbon  
 TSS = Total Suspended Solids

<sup>[1]</sup> There were five detected values and three nondetect values. To calculate an average, nondetect values were assumed to be ½ the detection limit.

<sup>[2]</sup> There were five detected values and two nondetect values. To calculate an average, nondetect values were assumed to be ½ the detection limit.

As shown in Table F-5, the Discharger met its numeric limits for stormwater. The Discharger also complied with its stormwater pH limitation. At all of the Discharger’s stormwater outfalls, pH values ranged from 7.0 to 8.5.

Although the previous order had no TSS effluent limit for stormwater, the TSS levels in stormwater have often exceeded the benchmark value of 100 mg/L contained in U.S. EPA’s *NPDES Stormwater Multi-Sector General Permit for Industrial Activities* (Federal Register Volume 65, Number 210, October 30, 2000). The average stormwater TSS level exceeded the benchmark value at three of the stormwater outfalls.

To address high levels of TSS at sampling stations T2S-B and T4NW, the Discharger stated plans to install underground settlement collection vaults at both of these locations prior to the 2015-2016 wet season. Recent sampling results indicate that TSS levels are very high at both of these locations. In December 2014, TSS levels were around 300 mg/L at T2-B and 2,600 mg/L at T4NW. As these two stormwater discharge points contain TSS levels well above expected benchmarks values, Provision VI.C.4.c of this Order requires the Discharger to install, and certify that it has installed, underground settlement collection vaults at these two locations by October 1, 2015.

#### **D. Compliance Summary**

- 1. Treatment Plant.** During the previous order (July 2010 through December 2014), the Discharger violated its total coliform limitation four times. To address three of these violations, the Regional Water Board imposed mandatory minimum penalties (Order No. R2-2012-0048). The fourth total coliform violation is not subject to a mandatory minimum penalty since no other effluent violations occurred within six months of that violation. To minimize future episodic total coliform violations, the Discharger stated plans for upgrading in 2016 the hypochlorite storage and distribution system at the D-2 Sanitary Sewer Location.
- 2. Collection System.** The Discharger's Maintenance Department is responsible for cleaning, repairing, and maintaining the oily water collection system (Collection System) at the Facility. The Discharger cleans drain inlets, manholes, major trunks, and feeder trunks annually, or semi-annually, using truck mounted water jetting equipment. When the Discharger recovers material during cleaning, it evaluates the potential for line failure (e.g., recovery of sand or gravel may indicate pipe structural problems). If anomalies are documented, the Discharger will inspect these areas by remote video or excavation and direct visual inspection. The Refinery Operations Group routinely operates and monitors the Collection System for proper operation. Problems with draining or inlet backups are reported to the Maintenance Department for cleaning or repair. If the Discharger discovers obsolete lines, it will seal them off from the active Collection System by pumping them full of cement-based grout.

#### **E. Planned Changes**

There are no expected planned changes at this time.

### **III. APPLICABLE PLANS, POLICIES, AND REGULATIONS**

The requirements in this Order are based on the requirements and authorities described below:

#### **A. Legal Authorities**

This Order serves as WDRs pursuant to California Water Code article 4, chapter 4, division 7 (commencing with § 13260). This Order is also issued pursuant to Clean Water Act (CWA) section 402 and implementing regulations adopted by U.S. EPA and Water Code chapter 5.5, division 7 (commencing with § 13370). It shall serve as an NPDES permit for point source discharges from this facility to surface waters.

**B. California Environmental Quality Act**

Under Water Code section 13389, this action to adopt an NPDES permit is exempt from the provisions of the California Environmental Quality Act, Public Resources Code division 13, chapter 3 (commencing with § 21100).

**C. State and Federal Regulations, Policies, and Plans**

**1. Water Quality Control Plan.** The Regional Water Board adopted the *Water Quality Control Plan for the San Francisco Bay Basin* (Basin Plan), which designates beneficial uses, establishes water quality objectives, and contains implementation programs and policies to achieve those objectives for all waters addressed through the plan. Requirements in this Order implement the Basin Plan. In addition, this Order implements State Water Board Resolution No. 88-63, which established State policy that all waters, with certain exceptions, should be considered suitable or potentially suitable for municipal or domestic supply. Because of the marine influence on Suisun Bay, total dissolved solids levels exceed 3,000 mg/L; therefore, Suisun Bay meets an exception to State Water Board Resolution No. 88-63. Beneficial uses applicable to Suisun Bay are as follows:

**Table F-6. Beneficial Uses**

Discharge Point	Receiving Water	Beneficial Uses
001, 003, 004 and 005-T2NW, 005-T2S-A, 005-T2S-B, 005-T2S-C, 005-T2SW, 005-T4NW, 005-T4SW, 006 <sup>[1]</sup>	Suisun Bay	Ocean, Commercial and Sport Fishing (COMM) Industrial Process Supply (PRO) Estuarine Habitat (EST) Industrial Service Supply (IND) Fish Migration (MIGR) Navigation (NAV) Preservation of Rare and Endangered Species (RARE) Water Contact Recreation (REC1) Non-Contact Water Recreation (REC2) Wildlife Habitat (WILD) Fish Spawning (SPWN)

<sup>[1]</sup> Outfalls 003, 004, 005, and 006 flow to Walnut Creek or Hastings Slough both of which flow to Suisun Bay. Beneficial uses of Suisun Bay apply to these creeks due to the Tributary Rule.

**2. Sediment Quality.** The State Water Board adopted the *Water Quality Control Plan for Enclosed Bays and Estuaries – Part 1, Sediment Quality* on September 16, 2008, and it became effective on August 25, 2009. This plan supersedes other narrative sediment quality objectives, and establishes new sediment quality objectives and related implementation provisions for specifically defined sediments in most bays and estuaries. This Order implements the sediment quality objectives of this plan.

**3. National Toxics Rule (NTR) and California Toxics Rule (CTR).** U.S. EPA adopted the NTR on December 22, 1992, and amended it on May 4, 1995 and November 9, 1999. About 40 criteria in the NTR apply in California. On May 18, 2000, U.S. EPA adopted the CTR. The CTR promulgated new toxics criteria for California and incorporated the previously adopted NTR criteria that applied in the State. U.S. EPA amended the CTR on February 13, 2001. These rules contain water quality criteria for priority pollutants.

- 4. State Implementation Policy.** On March 2, 2000, the State Water Board adopted the *Policy for Implementation of Toxics Standards for Inland Surface Waters, Enclosed Bays, and Estuaries of California* (State Implementation Policy or SIP). The SIP became effective on April 28, 2000, with respect to the priority pollutant criteria U.S. EPA promulgated for California through the NTR and the priority pollutant objectives the Regional Water Board established in the Basin Plan. The SIP became effective on May 18, 2000, with respect to the priority pollutant criteria U.S. EPA promulgated through the CTR. The State Water Board adopted amendments to the SIP on February 24, 2005, that became effective on July 13, 2005. The SIP establishes implementation provisions for priority pollutant criteria and objectives, and provisions for chronic toxicity control. Requirements of this Order implement the SIP.
- 5. Antidegradation Policy.** Federal regulations at 40 C.F.R. section 131.12 requires that state water quality standards include an antidegradation policy consistent with the federal policy. The State Water Board established California's antidegradation policy through State Water Board Resolution No. 68-16, *Statement of Policy with Respect to Maintaining High Quality of Waters in California*, which is deemed to incorporate the federal antidegradation policy where the federal policy applies under federal law. Resolution No. 68-16 requires that existing water quality be maintained unless degradation is justified based on specific findings. The Basin Plan implements, and incorporates by reference, both the State and federal antidegradation policies. Permitted discharges must be consistent with the antidegradation provisions of 40 C.F.R. section 131.12 and State Water Board Resolution No. 68-16.
- 6. Anti-Backsliding Requirements.** CWA sections 402(o) and 303(d)(4) and 40 C.F.R. section 122.44(l) restrict backsliding in NPDES permits. These anti-backsliding provisions require that effluent limitations in a reissued permit be as stringent as those in the previous permit, with some exceptions in which limitations may be relaxed.

#### **D. Impaired Waters on CWA 303(d) List**

In October 2011, U.S. EPA approved a revised list of impaired waters prepared pursuant to CWA section 303(d), which requires identification of specific water bodies where it is expected that water quality standards will not be met after implementation of technology-based effluent limitations on point sources. Where it has not done so already, the Regional Water Board plans to adopt total maximum daily loads (TMDLs) for pollutants on the 303(d) list. TMDLs establish wasteload allocations for point sources and load allocations for non-point sources and are established to achieve the water quality standards for the impaired waters.

San Francisco Bay is listed as impaired by chlordane, DDT, dieldrin, dioxin compounds, invasive species, furan compounds, mercury, PCBs, dioxin-like PCBs, and selenium. On February 12, 2008, U.S. EPA approved a TMDL for mercury in San Francisco Bay. On March 29, 2010, U.S. EPA approved a TMDL for PCBs in San Francisco Bay. The TMDLs for mercury and PCBs apply to this discharge and are implemented under NPDES Permit No. CA0038849. Also, as shown in Fact Sheet section IV.C.3, the discharge is not a significant source of chlordane, DDT, diazinon, or dieldrin because these pollutants have not been detected in the discharge.

## IV. RATIONALE FOR EFFLUENT LIMITATIONS AND DISCHARGE SPECIFICATIONS

The CWA requires point source dischargers to control the amount of conventional, non-conventional, and toxic pollutants discharged into waters of the United States. The control of pollutants discharged is established through effluent limitations and other requirements in NPDES permits. There are two principal bases for effluent limitations: 40 C.F.R. section 122.44(a) requires that permits include applicable technology-based limitations and standards; and 40 C.F.R. section 122.44(d) requires that permits include water quality-based effluent limitations to attain and maintain applicable numeric and narrative water quality criteria to protect the beneficial uses of receiving waters.

### A. Discharge Prohibitions

- 1. Discharge Prohibition III.A (No discharge other than as described in this Order):** This prohibition is based on 40 C.F.R. section 122.21(a) and Water Code section 13260, which require filing an application and Report of Waste Discharge before a discharge can occur. Discharges not described in the application and Report of Waste Discharge, and subsequently in this Order, are prohibited.
- 2. Discharge Prohibition III.B (Minimum initial dilution ratio of 15:1 at Discharge Point No. 001):** This Order allows a conservative estimate of the actual initial dilution of 15:1 to calculate WQBELs for ammonia. Therefore, this prohibition is necessary to ensure that the assumptions used to derive the dilution credit remain substantially the same so the limitations remain protective of water quality.

This Order permits discharge of stormwater from 11 outfalls that do not provide an initial dilution of at least 10:1. Though Discharge Prohibition No. 1 of the Basin Plan prohibits discharges having characteristics of particular concern that do not receive a minimum 10:1 initial dilution, the Basin Plan further indicates that the prohibition is to address discharges of treated sewage and other discharges where the treatment process is subject to upset. Since these stormwater discharges do not contain treated sewage or wastewater from a treatment process subject to upset, the prohibition does not apply to these stormwater discharges.

- 3. Discharge Prohibition III.C (No bypass or overflow of untreated or partially-treated wastewater, except as provided for in Attachment D):** This prohibition is based on 40 C.F.R. section 122.41(m) (see Attachment D section I.G). It does not apply to treated wastewater bypassing GAC units when toxicity levels are below effluent limitations.

### B. Conventional and Non-Conventional Pollutant Effluent Limitations

#### 1. Scope and Authority

CWA section 301(b) and 40 CFR 122.44(a) require that permits include applicable technology-based limitations based on several levels of control:

- a. Best practicable treatment control technology (BPT) represents the average of the best performance by plants within an industrial category or subcategory. BPT standards apply to toxic, conventional, and non-conventional pollutants. Conventional pollutants include BOD, TSS, pH, and oil and grease.



- b. Best available technology economically achievable (BAT) represents the best existing performance of treatment technologies that are economically achievable within an industrial point source category. BAT standards apply to toxic and non-conventional pollutants.
- c. Best conventional control technology (BCT) represents the control from existing industrial point sources of conventional pollutants. The BCT standard is established after considering the “cost reasonableness” of the relationship between the cost of attaining a reduction in effluent discharge and the benefits that would result, and also the cost effectiveness of additional industrial treatment beyond BPT.
- d. New source performance standards (NSPS) represent the best available demonstrated control technology standards for new sources. The intent of NSPS guidelines is to set limitations that represent state-of-the-art treatment technology for new sources.

Where U.S. EPA has not yet developed technology-based standards for a particular industry or a particular pollutant, CWA section 402(a)(1) and 40 CFR 125.3 authorize the use of best professional judgement (BPJ) to derive technology-based effluent limitations on a case-by-case basis. When BPJ is used, the permit must reflect specific factors outlined at 40 CFR 125.3.

U.S. EPA has established standards of performance (technology-based limitations and standards) for the petroleum refining industry at 40 CFR 419, *Effluent Limitations Guidelines for the Petroleum Refining Point Source Category*. Subpart B of these regulations for the Cracking Refinery Subcategory apply to discharges from the Facility and have been used to develop limitations and requirements of this Order.

## **2. Technology-Based Effluent Limitations**

### **a. Technology-Based Effluent Limitations – Discharge Point 001.**

40 CFR 419 Subpart B requires that technology-based effluent limitations for Discharge Point 001 be derived based on refinery production (the total crude oil throughput of the Facility) and the treatment processes used. The Facility currently operates with a maximum crude oil throughput of 143,600 bbls/day.

Additional ballast water (i.e., cargo hold wash water) effluent limitation allocations are developed from requirements in 40 CFR 419.22(c), 419.23(d), and 419.24(c). These allocations are in addition to the process wastewater mass-based limitations. A full description of the effluent limitation allocations for Discharge Point 001 can be found in Attachment F-1 to this Order.

### **b. Effluent Limitations for Stormwater**

Based on the requirements of 40 CFR 419 Subpart B for stormwater discharges, this Order establishes technology-based limitations for Discharge Points 003 – 006. This Order also retains the narrative stormwater limits of no visible oil or color.

If the limitation for total organic carbon (TOC) or oil and grease is exceeded, additional limitations for BOD, TSS, COD, oil and grease, phenolic compounds, total chromium,

and hexavalent chromium become immediately effective for the discharge point where that exceedance occurred. Derivation of the stormwater effluent limitations based on 40 CFR 419 Subpart B is presented in detail in Attachment F-1 to this Order. The additional effluent limit on pH of 6.0 to 9.0 from 40 CFR 419 Subpart B is not established by this Order. The Basin Plan pH effluent limit for shallow water discharges of 6.5 to 8.5 is retained instead to satisfy anti-backsliding requirements.

## C. Toxic Pollutant Effluent Limitations

### 1. Scope and Authority

For toxic pollutants, this Order contains water quality based effluent limitations (WQBELs) that implement water quality objectives that protect beneficial uses. CWA section 301(b) and 40 C.F.R. section 122.44(d) require that permits include limitations more stringent than federal technology-based requirements where necessary to achieve applicable water quality standards. According to 40 C.F.R. section 122.44(d)(1)(i), permits must include effluent limitations for all pollutants that are or may be discharged at levels that have a reasonable potential to cause or contribute to an exceedance of a water quality standard, including numeric and narrative objectives within a standard. Where reasonable potential has been established for a pollutant, but there is no numeric criterion or objective, WQBELs must be established using (1) U.S. EPA criteria guidance under CWA section 304(a), supplemented where necessary by other relevant information; (2) an indicator parameter for the pollutant of concern; or (3) a calculated numeric water quality criterion, such as a proposed state criterion or policy interpreting a narrative criterion, supplemented with relevant information (40 C.F.R. § 122.44[d][1][vi]). The process for determining reasonable potential and calculating WQBELs is intended to achieve applicable water quality objectives and criteria, and protect designated uses of receiving waters as specified in the Basin Plan. This Order imposes numeric effluent limitations for toxic pollutants with reasonable potential to cause or contribute to exceedances of water quality standards.

### 2. Beneficial Uses and Water Quality Criteria and Objectives

Discharge Point No. 001 discharges to Suisun Bay. Section III.C.1, above, identifies the beneficial uses of Suisun Bay. Water quality criteria and objectives to protect these beneficial uses are described below:

- a. Basin Plan Objectives.** The Basin Plan specifies numeric water quality objectives for 10 priority pollutants and narrative water quality objectives for toxicity and bioaccumulation. The narrative toxicity objective states, “All waters shall be maintained free of toxic substances in concentrations that are lethal to or that produce other detrimental responses in aquatic organisms.” The narrative bioaccumulation objective states, “Controllable water quality factors shall not cause a detrimental increase in concentrations of toxic substances found in bottom sediments or aquatic life. Effects on aquatic organisms, wildlife, and human health will be considered.”
- b. CTR Criteria.** The CTR specifies numeric aquatic life and human health criteria for numerous priority pollutants. These criteria apply to inland surface waters and enclosed bays and estuaries. Some human health criteria are for consumption of “water and organisms” and others are for consumption of “organisms only.” The criteria applicable

to “organisms only” apply to Central San Francisco Bay because it is not a source of drinking water.

- c. **NTR Criteria.** The NTR establishes numeric aquatic life and human health criteria for a number of toxic pollutants for San Francisco Bay waters upstream to and including Suisun Bay and the Sacramento-San Joaquin Delta. The NTR criteria apply to Suisun Bay.
- d. **Sediment Quality Objectives.** The *Water Quality Control Plan for Enclosed Bays and Estuaries – Part 1, Sediment Quality* contains a narrative water quality objective: “Pollutants in sediments shall not be present in quantities that, alone or in combination, are toxic to benthic communities in bays and estuaries of California.” This objective is to be implemented by integrating three lines of evidence: sediment toxicity, benthic community condition, and sediment chemistry. The policy requires that if the Regional Water Board determines that a discharge has reasonable potential to cause or contribute to an exceedance of this objective, it is to impose the objective as a receiving water limit.
- e. **Receiving Water Salinity.** Basin Plan section 4.6.2 (like the CTR and NTR) states that the salinity characteristics (i.e., freshwater vs. saltwater) of the receiving water are to be considered in determining applicable water quality objectives. Freshwater criteria apply to discharges to waters with salinities equal to or less than one part per thousand (ppt) at least 95 percent of the time. Saltwater criteria apply to discharges to waters with salinities equal to or greater than 10 ppt at least 95 percent of the time in a normal water year. For discharges to waters with salinities between these two categories, or tidally-influenced freshwaters that support estuarine beneficial uses, the water quality objectives are the lower of the salt or freshwater objectives (the latter calculated based on ambient hardness) for each substance.

Suisun Bay is an estuarine environment based on salinity data generated through the Regional Monitoring Program (RMP). Salinity data were collected at the Pacheco Creek (BF10) sampling location between 1993 and 2001. During that period, the average salinity was 4.2 ppt, with a range from 0 to 12.8 ppt. Because the salinity was between 1 and 10 ppt in 33 percent of the receiving water samples, Suisun Bay is classified as estuarine, and the reasonable potential analysis and WQBELs are based on saltwater and freshwater water quality criteria and objectives.

- f. **Site-Specific Metals Translators.** Effluent limitations for metals must be expressed as total recoverable metal (40 C.F.R. § 122.45[c]). Since the water quality objectives for metals are typically expressed as dissolved metal, translators must be used to convert metals concentrations from dissolved to total recoverable and vice versa. The CTR contains default translators; however, site-specific conditions, such as water temperature, pH, total suspended solids, and organic carbon may affect the form of metal (dissolved, non-filterable, or otherwise) present and therefore available to cause toxicity. In general, dissolved metals are more available and more toxic to aquatic life than other forms. Site-specific translators can account for site-specific conditions, thereby preventing overly stringent or under-protective water quality objectives. For copper, Basin Plan Table 7.2.1-2 contains site-specific translators for deep-water discharges to Suisun Bay: 0.38 and 0.66 (monthly and daily). For nickel, this Order uses site-specific translators the Clean Estuary Partnership developed, as set forth in *North of Dumbarton Bridge Copper*

*and Nickel Development and Selection of Final Translators* report (March 2005): 0.27 and 0.57 (monthly and daily).

### 3. Need for Water Quality-Based Effluent Limitations (Reasonable Potential Analysis)

Assessing whether a pollutant has reasonable potential to exceed a water quality objective is the fundamental step in determining whether a WQBEL is required:

- a. **Methodology.** SIP section 1.3 sets forth the methodology used for this Order for assessing whether a pollutant has reasonable potential to exceed a water quality objective. The analysis begins with identifying the maximum effluent concentration (MEC) observed for each pollutant based on available effluent concentration data and the ambient background concentration (B). SIP section 1.4.3 states that ambient background concentrations are either the maximum ambient concentration observed or, for water quality objectives intended to protect human health, the arithmetic mean of observed concentrations. There are three triggers in determining reasonable potential:
  - i. **Trigger 1** is activated if the maximum effluent concentration is greater than or equal to the lowest applicable water quality objective ( $MEC \geq$  water quality objective).
  - ii. **Trigger 2** is activated if the ambient background concentration observed in the receiving water is greater than the lowest applicable water quality objective ( $B >$  water quality objective) *and* the pollutant is detected in any effluent sample.
  - iii. **Trigger 3** is activated if a review of other information indicates that a WQBEL is needed to protect beneficial uses.
- b. **Effluent Data.** The reasonable potential analysis for this Order is based on effluent monitoring data the Discharger collected from March 2011 through December 2014.
- c. **Ambient Background Data.** The reasonable potential analysis for this Order is based on RMP data collected at the Yerba Buena Island station (BC10) from 1993 through 2013, and additional Bay Area Clean Water Agencies data from *San Francisco Bay Ambient Water Monitoring Interim Report* (2003) and *Ambient Water Monitoring: Final CTR Sampling Update* (2004). These reports contain monitoring results from 2002 and 2003 for priority pollutants the RMP did not monitor at the time.

SIP section 1.4.3 requires that background water quality data be representative of the ambient receiving water that will mix with the discharge. RMP monitoring station BC10, relative to other RMP stations, fits SIP guidance for establishing background conditions.

- d. **Reasonable Potential Analysis for Toxic Pollutants.** The maximum effluent concentrations, most stringent applicable water quality criteria and objectives, and ambient background concentrations used in the analysis are presented in the following table, along with the reasonable potential analysis results (yes or no) for each pollutant. Reasonable potential was not determined for all pollutants because there are not water quality objectives for all pollutants, and monitoring data are unavailable for others.

Copper, cyanide, lead, selenium, and ammonia exhibit reasonable potential by Trigger 1. Dioxin-TEQ exhibits reasonable potential by Trigger 2. Basin Plan section 7.2.1.2 also

requires copper WQBELs for all municipal and industrial wastewater treatment facilities discharging into San Francisco Bay.

**Table F-7. Reasonable Potential Analysis**

CTR #	Priority Pollutants	Governing criterion or objective (µg/L)	MEC or Minimum DL <sup>[1][2]</sup> (µg/L)	B or Minimum DL <sup>[1][2]</sup> (µg/L)	Results <sup>[3]</sup>
1	Antimony	4,300	4.8	1.8	No
2	Arsenic	36	10	2.8	No
3	Beryllium	No Criteria	<0.06	0.22	U
4	Cadmium	9.36	<0.04	0.13	No
5a	Chromium (III)	No Criteria	Unavailable	4.4	U
5b	Chromium (VI)	50	4	4.4	No
<b>6</b>	<b>Copper</b>	<b>14.2</b>	<b>24</b>	<b>2.5</b>	<b>Yes</b>
<b>7</b>	<b>Lead</b>	<b>2.7</b>	<b>2.9</b>	<b>0.8</b>	<b>Yes</b>
8	Mercury (303(d) listed) <sup>[4]</sup>	---	0.028	---	---
9	Nickel	30	9.4	3.7	No
<b>10</b>	<b>Selenium</b>	<b>5</b>	<b>49</b>	<b>0.39</b>	<b>Yes</b>
11	Silver	2.2	<0.02	0.052	No
12	Thallium	6.3	<0.05	0.21	No
13	Zinc	86	7.5	5.1	No
<b>14</b>	<b>Cyanide</b>	<b>2.9</b>	<b>12</b>	<b>&lt; 0.4</b>	<b>Yes</b>
15	Asbestos	No Criteria	Unavailable	Unavailable	U
16	2,3,7,8-TCDD (303(d) listed)	1.40x10 <sup>-8</sup>	<2.2 E-7	8.2 x 10 <sup>-9</sup>	No
	<b>Dioxin-TEQ (303(d) listed)</b>	<b>1.40x10<sup>-8</sup></b>	<b>2.85 E-10</b>	<b>5.3 x 10<sup>-8</sup></b>	<b>Yes</b>
17	Acrolein	780	<1.7	<0.5	No
18	Acrylonitrile	0.66	<0.7	0.03	No
19	Benzene	71	<0.18	<0.05	No
20	Bromoform	360	<0.15	<0.5	No
21	Carbon Tetrachloride	4.4	<0.16	0.06	No
22	Chlorobenzene	21,000	<0.18	<0.5	No
23	Chlorodibromomethane	34	4	<0.05	No
24	Chloroethane	No Criteria	<0.38	<0.5	U
25	2-Chloroethylvinyl ether	No Criteria	<0.28	<0.5	U
26	Chloroform	No Criteria	1.3	<0.5	U
27	Dichlorobromomethane	46	0.7	<0.05	No
28	1,1-Dichloroethane	No Criteria	<0.19	<0.05	U
29	1,2-Dichloroethane	99	<0.18	0.04	No
30	1,1-Dichloroethylene	3.2	<0.21	<0.5	No
31	1,2-Dichloropropane	39	<0.18	<0.05	No
32	1,3-Dichloropropylene	1,700	<0.29	<0.5	No
33	Ethylbenzene	29,000	<0.26	<0.5	No
34	Methyl Bromide	4,000	2.9	<0.5	No
35	Methyl Chloride	No Criteria	<0.23	<0.5	U
36	Methylene Chloride	1,600	<0.2	22	No
37	1,1,2,2-Tetrachloroethane	11	<0.1	<0.05	No
38	Tetrachloroethylene	8.85	<0.19	<0.05	No
39	Toluene	200,000	<0.19	<0.3	No
40	1,2-Trans-Dichloroethylene	140,000	<0.22	<0.5	No
41	1,1,1-Trichloroethane	No Criteria	<0.19	<0.5	U
42	1,1,2-Trichloroethane	42	<0.16	<0.05	No
43	Trichloroethylene	81	<0.2	<0.5	No
44	Vinyl Chloride	525	<0.25	<0.5	No
45	2-Chlorophenol	400	<0.7	<1.2	No
46	2,4-Dichlorophenol	790	<0.9	<1.3	No
47	2,4-Dimethylphenol	2,300	<0.8	<1.3	No
48	2-Methyl- 4,6-Dinitrophenol	765	<0.6	<1.2	No
49	2,4-Dinitrophenol	14,000	<0.83	<0.7	No

CTR #	Priority Pollutants	Governing criterion or objective (µg/L)	MEC or Minimum DL <sup>[1][2]</sup> (µg/L)	B or Minimum DL <sup>[1][2]</sup> (µg/L)	Results <sup>[3]</sup>
50	2-Nitrophenol	No Criteria	<0.5	<1.3	U
51	4-Nitrophenol	No Criteria	<0.8	<1.6	U
52	3-Methyl 4-Chlorophenol	No Criteria	<0.6	<1.1	U
53	Pentachlorophenol	7.9	<0.6	<1	No
54	Phenol	4,600,000	55	<1.3	No
55	2,4,6-Trichlorophenol	6.5	Unavailable	<1.3	U
56	Acenaphthene	2,700	<0.01	0.0019	No
57	Acenaphthylene	No Criteria	<0.02	0.0013	U
58	Anthracene	110,000	<0.01	0.0006	No
59	Benzidine	0.00054	<5	<0.0015	No
60	Benzo(a)Anthracene	0.049	<0.02	0.0053	No
61	Benzo(a)Pyrene	0.049	<0.01	0.0033	No
62	Benzo(b)Fluoranthene	0.049	<0.01	0.0046	No
63	Benzo(ghi)Perylene	No Criteria	<0.02	0.0045	U
64	Benzo(k)Fluoranthene	0.049	<0.01	0.0018	No
65	Bis(2-Chloroethoxy)Methane	No Criteria	<0.9	<0.3	U
66	Bis(2-Chloroethyl)Ether	1.4	<0.7	<0.00015	No
67	Bis(2-Chloroisopropyl)Ether	170,000	<0.6	Unavailable	No
68	Bis(2-Ethylhexyl)Phthalate	5.9	<0.6	<0.7	No
69	4-Bromophenyl Phenyl Ether	No Criteria	<0.7	<0.23	U
70	Butylbenzyl Phthalate	5,200	<0.7	0.0056	No
71	2-Chloronaphthalene	4,300	<0.9	<0.3	No
72	4-Chlorophenyl Phenyl Ether	No Criteria	<0.9	<0.3	U
73	Chrysene	0.049	<0.01	0.0028	No
74	Dibenzo(a,h)Anthracene	0.049	<0.02	0.00064	No
75	1,2-Dichlorobenzene	17,000	<0.27	<0.3	No
76	1,3-Dichlorobenzene	2,600	<0.18	<0.3	No
77	1,4-Dichlorobenzene	2,600	<0.18	<0.3	No
78	3,3 Dichlorobenzidine	0.077	<5	<0.001	No
79	Diethyl Phthalate	120,000	<0.7	<0.21	No
80	Dimethyl Phthalate	2,900,000	<0.9	<0.21	No
81	Di-n-Butyl Phthalate	12,000	<0.6	0.016	No
82	2,4-Dinitrotoluene	9.1	<0.7	<0.27	No
83	2,6-Dinitrotoluene	No Criteria	<0.8	<0.29	U
84	Di-n-Octyl Phthalate	No Criteria	<0.5	<0.38	U
85	1,2-Diphenylhydrazine	0.54	<0.7	0.0037	No
86	Fluoranthene	370	<0.03	0.011	No
87	Fluorene	14,000	<0.01	0.0021	No
88	Hexachlorobenzene	0.00077	<0.7	0.000022	No
89	Hexachlorobutadiene	50	<0.6	<0.3	No
90	Hexachlorocyclopentadiene	17,000	<0.7	<0.31	No
91	Hexachloroethane	8.9	<0.6	<0.2	No
92	Indeno(1,2,3-cd)Pyrene	0.049	<0.02	0.004	No
93	Isophorone	600	<0.93	<0.3	No
94	Naphthalene	No Criteria	<0.02	0.013	U
95	Nitrobenzene	1,900	<0.9	<0.25	No
96	N-Nitrosodimethylamine	8.1	<0.5	<0.3	No
97	N-Nitrosodi-n-Propylamine	1.4	<0.8	<0.001	No
98	N-Nitrosodiphenylamine	16	<0.5	<0.001	No
99	Phenanthrene	No Criteria	<0.01	0.0095	U
100	Pyrene	11,000	0.06	0.019	No
101	1,2,4-Trichlorobenzene	No Criteria	<0.6	<0.3	U
102	Aldrin	0.00014	<0.004	0.0000028	No
103	Alpha-BHC	0.013	<0.005	0.0005	No
104	Beta-BHC	0.046	<0.004	0.00041	No

CTR #	Priority Pollutants	Governing criterion or objective (µg/L)	MEC or Minimum DL <sup>[1][2]</sup> (µg/L)	B or Minimum DL <sup>[1][2]</sup> (µg/L)	Results <sup>[3]</sup>
105	Gamma-BHC	0.063	<0.004	0.0007	No
106	Delta-BHC	No Criteria	<0.004	0.000053	U
107	Chlordane (303(d) listed)	0.00059	<0.005	0.00018	No
108	4,4'-DDT (303(d) listed)	0.00059	<0.004	0.00017	No
109	4,4'-DDE (linked to DDT)	0.00059	<0.003	0.00069	No
110	4,4'-DDD	0.00084	<0.004	0.00031	No
111	Dieldrin (303d listed)	0.00014	<0.004	0.00026	No
112	Alpha-Endosulfan	0.0087	<0.004	0.000031	No
113	beta-Endosulfan	0.0087	<0.005	0.000069	No
114	Endosulfan Sulfate	240	<0.005	0.000082	No
115	Endrin	0.0023	<0.005	0.00004	No
116	Endrin Aldehyde	0.81	<0.005	Unavailable	No
117	Heptachlor	0.00021	<0.005	0.000019	No
118	Heptachlor Epoxide	0.00011	<0.004	0.000094	No
119-125	PCBs sum (303(d) listed) <sup>[4]</sup>	---	<0.04	---	---
126	Toxaphene	0.0002	<0.2	Unavailable	No
	<b>Total Ammonia <sup>[5]</sup></b>	<b>1.24</b>	<b>24</b>	<b>0.20</b>	<b>Yes</b>

Footnotes:

- <sup>[1]</sup> The maximum effluent concentration and ambient background concentration are the actual detected concentrations unless preceded by a “<” sign, in which case the value shown is the minimum detection level (DL).
- <sup>[2]</sup> The maximum effluent concentration or ambient background concentration is “Unavailable” when there are no monitoring data for the constituent.
- <sup>[3]</sup> RPA Results = Yes, if MEC ≥ WQC, B > WQC and MEC is detected, or Trigger 3  
 = No, if MEC and B are < WQC or all effluent data are undetected  
 = Unknown, cannot determine (U), if no criteria have been promulgated or data are insufficient.
- <sup>[4]</sup> SIP section 1.3 excludes from its reasonable potential analysis procedure priority pollutants for which a TMDL has been developed. TMDLs have been developed for mercury and PCBs in San Francisco Bay. Mercury and PCBs from wastewater discharges are regulated by NPDES Permit No. CA0038849, which implements the San Francisco Bay Mercury and PCBs TMDLs.
- <sup>[5]</sup> Units for total ammonia are milligrams per liter as nitrogen.

**e. Pollutants with No Reasonable Potential.** This Order does not contain WQBELs for constituents that do not demonstrate reasonable potential; however, Provision VI.C.2 of the Order still requires monitoring for those pollutants. If concentrations are found to have increased significantly, Provision VI.C.2 of the Order requires the Discharger to investigate the sources of the increases and implement remedial measures if the increases pose a threat to receiving water quality.

**f. Reasonable Potential Analysis for Sediment Quality.** Pollutants in some receiving water sediments may be present in quantities that alone or in combination are toxic to benthic communities. Efforts are underway to identify stressors causing such conditions. However, to date there is no evidence directly linking compromised sediment conditions to the discharges subject to this Order; therefore, the Regional Water Board cannot draw a conclusion about reasonable potential for these discharges to cause or contribute to exceedances of the sediment quality objectives. Nevertheless, the Discharger continues to participate in the RMP, which monitors San Francisco Bay sediment and seeks to identify stressors responsible for degraded sediment quality. Thus far, the monitoring has provided only limited information about potential stressors and sediment transport. The Regional Water Board is exploring options for obtaining additional information that may inform future analyses.

#### 4. Water Quality-Based Effluent Limitations (WQBELs)

WQBELs were developed for the pollutants determined to have reasonable potential to cause or contribute to exceedances of water quality objectives. The WQBELs are based on the procedures specified in SIP section 1.4.

**a. Dilution Credits.** SIP section 1.4.2 allows dilution credits for completely-mixed discharges and, under certain circumstances, incompletely-mixed discharges. The outfall at Discharge Point 001 is designed to achieve a minimum initial dilution of 10:1. The actual dilution has been estimated using the U.S. EPA-supported plume-modeling program UDKHDEN. Model results were reported in a technical report prepared by S.R. Hansen & Associates, titled *Initial Dilution Modeling and Dye Dispersion Studies for the Effluent Discharged from the Tosco Avon Refinery* (March, 1990). The worst-case initial dilution factor calculated was 15:1 at a flow rate of 0.176 m<sup>3</sup>/s (4 MGD). This dilution factor was calculated at slack tide and under stratified conditions. The flow rate of 4 MGD is approximately equal to the average flow rate reported by the Discharger of 4.4 MGD.

**i. Bioaccumulative Pollutants.** For certain bioaccumulative pollutants, dilution credit is significantly restricted or denied. Specifically, these pollutants include dioxin and furan compounds, which appear on the CWA section 303(d) list for Central San Francisco Bay because, based on available data on the concentrations of these pollutants in aquatic organisms, sediment, and the water column, they impair San Francisco Bay beneficial uses. The following factors suggest insufficient assimilative capacity in San Francisco Bay for these pollutants.

Tissue samples taken from San Francisco Bay fish show the presence of these pollutants at concentrations greater than screening levels (*Contaminant Concentrations in Fish from San Francisco Bay*, May 1997). The results of a 1994 San Francisco Bay pilot study, presented in *Contaminated Levels in Fish Tissue from San Francisco Bay* (Regional Water Board, 1994), also show elevated levels of chemical contaminants in fish tissues. The Office of Environmental Health and Hazard Assessment completed a preliminary review of the data in the 1994 report and in December 1994 issued an interim consumption advisory covering certain fish species in San Francisco Bay due to the levels of some of these pollutants. The Office of Environmental Health and Hazard Assessment updated this advisory in a May 2011 report, *Health Advisory and Safe Eating Guidelines for San Francisco Bay Fish and Shellfish*, which still suggests insufficient assimilative capacity in San Francisco Bay for 303(d)-listed pollutants. Therefore, dilution credits are denied for bioaccumulative pollutants on the 303(d) list for which data are lacking on sources and significant uncertainty exists about how different sources contribute to bioaccumulation.

**ii. Selenium.** For selenium, San Francisco Bay waterfowl tissue data presented in the California Department of Fish and Wildlife's Selenium Verification Study (1986-1990) showed elevated selenium levels in the livers of waterfowl that feed on bottom-dwelling organisms, such as clams. In addition, the Office of Environmental Health and Hazard Assessment issued an advisory in 1987 for consumption of two species of diving ducks in the North Bay found to have high tissue levels of selenium.



This advisory is still in effect. Elevated selenium levels have also been found in the tissue of white sturgeon, which also feed on clams.

This information, together with high uncertainty regarding how different sources of selenium contribute to bioaccumulation, has previously led the Regional Water Board to deny dilution credit for selenium. However, the region's refineries have significantly reduced their discharges of selenium and have altered the chemical forms of the selenium they discharge so the selenium is generally less bioavailable. Also, substantially more information has become available to advance the development of a selenium TMDL for north San Francisco Bay segments. Recent work reduces some uncertainties regarding selenium sources, fate, and transport, and suggests that some assimilative capacity remains in the receiving waters. Based on this preliminary information, Regional Water Board staff concludes that limited dilution credit for selenium may be granted such that existing refinery performance is maintained, pending the completion of a selenium TMDL. This Order grants limited dilution credits for selenium but only to a level that maintains existing refinery performance. When a selenium TMDL is completed, the Regional Water Board will amend these limits to be consistent with TMDL wasteload allocations. Granting dilution credits for selenium at this time is appropriate specifically because of the substantial new information about selenium in San Francisco Bay now available. This information does not apply to other pollutants. To calculate selenium WQBELs, this Order uses a dilution credit of  $D = 9$  (10:1 dilution).

- iii. Ammonia.** In calculating WQBELs for total ammonia, a non-persistent pollutant that quickly disperses and degrades, the estimated minimum initial dilution ratio of 15:1 was used for the acute objective and an estimated median initial dilution of 130:1 was used for the chronic annual median objective. Actual initial dilution is used because ammonia is not a persistent pollutant and the Basin Plan states, "In most instances, ammonia will be diluted or degraded to a nontoxic state fairly rapidly." As such, there is unlikely to be cumulative toxicity effects associated with discharges containing elevated concentrations of ammonia. Therefore, granting dilution credits based on actual initial dilution is protective of water quality.
- iv. Cyanide.** For cyanide, a non-persistent pollutant that quickly disperses and degrades like ammonia, a more conservative dilution rate of 10:1 was used to calculate the WQBELs. Whereas the action initial dilution of 15:1 was granted for ammonia, less dilution is granted for cyanide because SIP Section 1.4.2.2 dictates that mixing zones be as small as practicable. Limiting dilution is equivalent to decreasing the size of the allowed mixing zone. The different approach for cyanide (versus ammonia) reflects the fact that cyanide has been regulated in permits for decades in this region. As a result of past conservative policies and changes in policies and standards, the process for deriving effluent limits for cyanide is more stringent than those for ammonia to comply with antidegradation. In other words, because past policies have resulted in very stringent limitations, to backslide from these limits, CWA 303(d)(4) provides that there must be compliance with antidegradation policies. The background documentation for the cyanide site-specific objectives included an antidegradation analysis, which concluded that certain effluent limitations resulting from implementation of the site-specific objectives (assuming 10:1 dilution) would not degrade water quality. Therefore, the dilution credit used here is the dilution credit

that results in effluent limits no greater than those identified in the site-specific objectives documents for this Discharger. This resultant dilution credit for cyanide is also in compliance with the SIP, which requires the mixing zone be as small as practicable. Additionally, consistent with the site-specific objective conclusion on antidegradation, to further ensure that water quality is not degraded, this Order requires a cyanide action plan.

- v. Non-Bioaccumulative Pollutants.** For persistent non-bioaccumulative constituents, a conservative allowance of 10:1 dilution for discharges to the Bay has been assigned for protection of beneficial uses. Though this is less than the actual dilution achieved, limiting dilution credit for persistent non-bioaccumulative pollutants is based on SIP provisions, Section 1.4.2, that considers the following:
- (a)** San Francisco Bay is a complex estuarine system with highly variable and seasonal upstream freshwater inflows and diurnal tidal saltwater inputs. SIP section 1.4.3 allows background conditions to be determined on a discharge-by-discharge or water body-by-water body basis. A water body-by-water body approach is taken here due to inherent uncertainties in characterizing ambient background conditions in a complex estuarine system on a discharge-by-discharge basis.
  - (b)** Because of the complex hydrology of San Francisco Bay, there are uncertainties in accurately determining an appropriate mixing zone. The models used to predict dilution do not consider the three dimensional nature of San Francisco Bay currents resulting from the interaction of tidal flushes and seasonal freshwater outflows. Being heavier and colder than freshwater, ocean saltwater enters San Francisco Bay on a twice-daily tidal cycle, generally beneath the warmer freshwater that flows seaward. When these waters mix and interact, complex circulation patterns occur due to the varying densities of the fresh and ocean waters. The complex patterns occur throughout San Francisco Bay but are most prevalent in San Pablo Bay, Carquinez Strait, and Suisun Bay. The locations of this mixing and interaction change depending on the strength of each tide. Additionally, sediment loads from the Central Valley change on a long-term basis, affecting the depth of different parts of San Francisco Bay, resulting in alteration of flow patterns, mixing, and dilution at the outfall.

For non-bioaccumulative pollutants, the Yerba Buena Island RMP monitoring station (BC10), relative to other RMP stations, fits SIP guidance for establishing background conditions. SIP section 1.4.3 requires that background water quality data be representative of the ambient receiving water that will mix with the discharge. Because the WQBELs for non-bioaccumulative pollutants are based on a restricted dilution credit, water quality data from the Yerba Buena Island monitoring station best represents the water that will mix with the discharge.

- b. WQBEL Calculations.** For those pollutants with reasonable potential, average monthly effluent limitations (AMELs) and maximum daily effluent limitations (MDELs) were calculated as shown in the table below:

**Table F-8. WQBEL Calculations**

PRIORITY POLLUTANTS	Copper	Cyanide	Selenium	Lead	Dioxin-TEQ	Total Ammonia
Units	µg/L	µg/L	µg/L	µg/L	µg/L	µg/L
Basis and Criteria type	Basin Plan SSO	Basin Plan SSO	Basin Plan SSO	Basin Plan SSO	Basin Plan Narrative	Basin Plan Aquatic Life (acute)
Criteria -Acute	-----	-----	20	69	-----	-----
Criteria -Chronic	-----	-----	5	2.7	-----	-----
SSO Criteria -Acute	3.9	9.4	-----	-----	-----	4.66
SSO Criteria -Chronic	2.5	2.9	-----	-----	-----	-----
Water Effects ratio (WER)	2.4	1	1	1	1	1
Lowest WQO	14.2	2.9	5	2.7	1.40E-08	4.66
Site Specific Translator - MDEL	0.66	-----	-----	-----	-----	-----
Site Specific Translator - AMEL	0.38	-----	-----	-----	-----	-----
Dilution Factor (D) (if applicable)	9	9	9	9	0	14
No. of samples per month	4	4	4	4	4	4
Aquatic life criteria analysis required? (Y/N)	Y	Y	Y	Y	N	Y
HH criteria analysis required? (Y/N)	N	Y	N	N	Y	N
Applicable Acute WQO	14.2	9.4	20	69	-----	4.66
Applicable Chronic WQO	15.8	2.9	5	2.7	-----	-----
HH criteria	-----	220,000	-----	-----	1.40E-08	-----
Background (Maximum Conc for Aquatic Life calc)	2.55	0.4	0.39	0.84	5.32E-08	0.2
Background (Average Conc for Human Health calc)	-----	0.4	-----	-----	2.0 E-08	-----
Is the pollutant on the 303d list and/or bioaccumulative (Y/N)?	N	N	N	N	Y	N
ECA acute	119	90	196.5	686.6		67
ECA chronic	135	25	46.5	19.8		-----
ECA HH		2.20E+06	-----	-----	1.40E-08	-----
No. of data points <10 or at least 80% of data reported non detect? (Y/N)	N	N	N	N	Y	N
Average of effluent data points	1.2	3.4	9.3	0.9		5.0
Std. Dev. of effluent data points	3.2	1.8	4.8	0.4		5.5
CV calculated	2.65	0.53	0.51	0.5	N/A	1.11
CV (Selected) - Final	2.65	0.53	0.51	0.5	0.6	1.11
ECA acute mult99	0.10	0.36	0.37	0.37		0.185
ECA chronic mult99	0.16	0.56	0.58	0.58		-----
LTA acute	11.73	32.1	72	256		12.44
LTA chronic	21.53	14.3	26.7	11.5		-----
Minimum of LTAs	11.73	14.3	26.7	11.5		12.44
AMEL mult95	3.16	1.5	1.47	1.45	1.6	2.1
MDEL mult99	10.13	2.8	2.73	2.68	3.1	5.4
AMEL (aquatic life)	37	21	39	17		26
MDEL(aquatic life)	120	40	73	31		67
MDEL/AMEL Multiplier	3.21	1.9	1.86	1.84	2.0	2.6
AMEL (human health)	-----	2.2E+06	-----	-----	1.40E-08	-----

MDEL (human health)	-----	4.2E+06	-----	-----	2.81E-08	-----
Min. of AMEL for Aq. life vs HH	37	21	39	17	0	26
Min. of MDEL for Aq. Life vs HH	120	40	73	31	0	67
Previous order limit (AMEL)	13	21	41	3.7	1.40E-08	26
Previous order limit (max. daily)	24	42	50	7.8	2.8E-08	67
Final limit - AMEL	37	21	39	3.7	1.40E-08	26
Final limit - MDEL	120	40	50	7.8	2.80E-08	67

**c. Calculation of Pollutant-Specific WQBELs**

**(1) Copper**

- (a) *Copper WQC.* The most stringent applicable WQOs for copper are the Basin Plan’s site-specific chronic and acute marine WQOs, 6.0 and 9.4 µg/L, respectively, expressed as dissolved metal. Regional Water Board staff converted these WQOs to total recoverable metal using site-specific translators of 0.38 (chronic) and 0.66 (acute). This results in a chronic water quality criterion of 16 µg/L and an acute water quality criterion of 14.2 µg/L.
- (b) *RPA Results.* This Order establishes effluent limitations for copper, because the MEC of 24 µg/L exceeds the applicable water quality criteria for this pollutant, demonstrating reasonable potential by Trigger 1, as defined previously.
- (c) *Copper WQBELs.* WQBELs for copper, calculated according to SIP procedures, with an effluent data coefficient of variation (CV) of 2.65 and a dilution credit of D=9, are an AMEL of 37 µg/L and an MDEL of 120 µg/L. The previous order contained a more stringent AMEL of 13 µg/L and MDEL of 24 µg/L based on objectives from the CTR. The CTR objectives for copper have been superceded by site-specific objectives (SSOs). This Order includes the newly calculated copper limits based on copper SSOs.
- (d) *Anti-backsliding.* This Order satisfies anti-backsliding requirements because San Francisco Bay is in attainment for copper and, consistent with section 303(d)(4)(B), the Regional Water Board has satisfied antidegradation requirements as described in section D.2 of the Fact Sheet.

**(2) Cyanide**

- (a) *Cyanide WQC.* The most stringent applicable WQOs for cyanide are the Basin Plan’s site-specific chronic and acute marine WQOs, 2.9 and 9.4 µg/L, respectively, for protection of marine aquatic life in San Francisco Bay.
- (b) *RPA Results.* This Order establishes effluent limitations for cyanide because the MEC of 12 µg/L exceeds the most stringent applicable WQO of 2.9 µg/L, demonstrating Reasonable Potential by Trigger 1.
- (c) *Cyanide WQBELs.* WQBELs for cyanide calculated according to SIP procedures using a CV of 0.53 and a dilution credit of D = 9 are an AMEL of 21 ug/L and an

MDEL of 40 ug/L. The previous permit contained the same AMEL of 21 µg/L and a less stringent MDEL of 42 µg/L. This Order includes the newly calculated cyanide limits.

- (d) *Anti-backsliding*. This Order includes more stringent effluent limits than the previous permit, thereby satisfying anti-backsliding requirements.

### (3) Dioxin-TEQ

- (a) *Dioxin-TEQ WQO*. The Basin Plan narrative WQO for bioaccumulative substances states, “Many pollutants can accumulate on particulates, in sediments, or bioaccumulate in fish and other aquatic organisms. Controllable water quality factors shall not cause a detrimental increase in concentrations of toxic substances found in bottom sediments or aquatic life. Effects on aquatic organisms, wildlife, and human health will be considered.”

Because it is the consensus of the scientific community that dioxins and furans associate with particulates, accumulate in sediments, and bioaccumulate in the fatty tissue of fish and other organisms, the Basin Plan’s narrative bioaccumulation WQO applies to these pollutants. Elevated levels of dioxins and furans in San Francisco Bay fish tissue demonstrate that the narrative bioaccumulation WQO is not being met. U.S. EPA has therefore placed Central San Francisco Bay on its 303(d)-list of receiving waters where WQOs are not being met after imposition of applicable technology-based requirements.

When the CTR was promulgated, U.S. EPA stated its support of the regulation of dioxin and dioxin-like compounds through the use of toxicity equivalencies (TEQs). U.S. EPA stated, “For California waters, if the discharge of dioxin or dioxin-like compounds has reasonable potential to cause or contribute to a violation of a narrative criterion, numeric WQBELs for dioxin or dioxin-like compounds should be included in NPDES permits and should be expressed using a TEQ scheme” (65 Fed. Reg. 31695-31696, May 18, 2000). This Order uses a TEQ scheme based on a set of toxicity equivalency factors (TEFs) the World Health Organization developed in 1998, and a set of bioaccumulation equivalency factors (BEFs) U.S. EPA developed for the Great Lakes region (40 C.F.R. part 132, Appendix F) to convert the concentration of any congener of dioxin or furan into an equivalent concentration of 2,3,7,8-tetrachlorinated dibenzo-p-dioxin (2,3,7,8-TCDD). Although the 1998 World Health Organization scheme includes TEFs for dioxin-like PCBs, they are not included in this Order’s TEQ scheme.

The CTR establishes a numeric WQO for 2,3,7,8-TCDD of  $1.4 \times 10^{-8}$  µg/L for the protection of human health when aquatic organisms are consumed. The CTR criterion is used as a criterion for dioxin-TEQ because dioxin-TEQ represents a toxicity weighted concentration equivalent to 2,3,7,8-TCDD, thus translating the narrative bioaccumulation WQO into a numeric criterion.

- (b) *RPA Results*. TEFs and BEFs were used to express measured concentrations of 16 dioxin congeners in effluent and background samples as equivalent 2,3,7,8-TCDD concentrations. For each sample, the sum of these equivalent

concentrations is the dioxin-TEQ concentration. This Order establishes dioxin-TEQ WQBELs because the ambient background receiving water dioxin-TEQ concentration ( $5.3 \times 10^{-8}$   $\mu\text{g/L}$ ) exceeds the CTR numeric criterion for 2,3,7,8-TCDD ( $1.4 \times 10^{-8}$   $\mu\text{g/L}$ ) and dioxin-TEQ was detected in the effluent, demonstrating reasonable potential by Trigger 2.

- (c) *WQBELs*. WQBELs for dioxin-TEQ calculated using SIP procedures using the default CV of 0.6 and no dilution credit are an AMEL of  $1.4 \times 10^{-8}$  and an MDEL of  $2.8 \times 10^{-8}$   $\mu\text{g/L}$ . The previous permit included the same limits.
- (d) *Anti-backsliding*. Anti-backsliding requirements are satisfied because this Order retains the limits from the previous permit.

#### (4) Lead

- (a) *Lead WQC*. The most stringent applicable WQOs for lead are the Basin Plan's freshwater acute and chronic objectives for protection of aquatic life of 69  $\mu\text{g/L}$  and 2.7  $\mu\text{g/L}$ , as calculated using the receiving water hardness value of 88  $\text{mg/L}$ , as  $\text{CaCO}_3$ .
- (b) *RPA Results*. This Order establishes effluent limitations for lead because the MEC of 2.9  $\mu\text{g/L}$  exceeds the most stringent applicable WQO of 2.7  $\mu\text{g/L}$ , demonstrating Reasonable Potential by Trigger 1.
- (c) *WQBELs*. WQBELs for lead calculated according to SIP procedures using a CV of 0.5 and a dilution credit of  $D = 9$  are an AMEL of 17  $\mu\text{g/L}$  and an MDEL of 31  $\mu\text{g/L}$ . The previous permit included a more stringent AMEL of 3.7  $\mu\text{g/L}$  and a more stringent MDEL of 7.8  $\mu\text{g/L}$ . This Order retains the lead limits from the previous permit.
- (d) *Anti-backsliding*. Anti-backsliding requirements are satisfied because this Order retains the limits from the previous permit.

#### (5) Selenium

- (a) *Selenium WQC*. The most stringent applicable WQC for selenium are from the NTR for protection of aquatic life. The NTR establishes a saltwater and freshwater acute criterion of 20.0  $\mu\text{g/L}$  and chronic criterion of 5.0  $\mu\text{g/L}$ .
- (b) *RPA Results*. This Order establishes effluent limitations for selenium because the MEC of 49  $\mu\text{g/L}$  exceeds the most stringent applicable WQC for this pollutant, demonstrating Reasonable Potential by Trigger 1.
- (c) *WQBELs*. WQBELs for selenium calculated according to SIP procedures using a CV of 0.51 and a dilution credit of  $D = 9$  are an AMEL of 39  $\mu\text{g/L}$  and an MDEL of 73  $\mu\text{g/L}$ . The previous permit included a less stringent AMEL of 41  $\mu\text{g/L}$  and a more stringent MDEL of 50  $\mu\text{g/L}$ . This Order includes the newly calculated AMEL of 39  $\mu\text{g/L}$  and retains the more stringent MDEL of 50  $\mu\text{g/L}$  from the previous permit.

(d) *Anti-backsliding*. This Order includes more stringent effluent limits than the previous permit, thereby satisfying anti-backsliding requirements.

**(6) Total Ammonia**

(a) *Ammonia WQC*. The Basin Plan contains WQOs for un-ionized ammonia of 0.025 mg/L as an annual median and 0.16 mg/L as a maximum upstream of the San Francisco Bay Bridge. These objectives were translated from un-ionized ammonia concentrations to equivalent total ammonia concentrations (as nitrogen) since (1) sampling and laboratory methods are unavailable to analyze for un-ionized ammonia, and (2) the fraction of total ammonia that exists in the toxic un-ionized form depends on the pH, salinity, and temperature of the receiving water.

To translate the un-ionized ammonia objectives, pH, salinity, and temperature data were obtained from the RMP station nearest to the outfall (Pacheco Creek station, BF 10). The un-ionized fraction of total ammonia was calculated as follows:

$$\text{For salinity} > 10 \text{ ppt: fraction of NH}_3 = \frac{1}{1 + 10^{(pK - pH)}}$$

Where:

$$pK = 9.245 + 0.116(I) + 0.0324(298 - T) + \frac{0.0415(P)}{(T)}$$

$$I = \text{Molal ionic strength of saltwater} = \frac{19.9273(S)}{(1,000 - 1.005109(S))}$$

$S$  = Salinity (parts per thousand)

$T$  = Temperature (degrees Kelvin)

$P$  = Pressure (one atmosphere)

The median and 90<sup>th</sup> percentile un-ionized ammonia fractions were then used to express the annual average and the daily maximum un-ionized objectives as chronic and acute total ammonia criteria. This approach is consistent with U.S. EPA guidance on translating dissolved metal water quality objectives to total recoverable metal WQOs (U.S. EPA, 1996, *The Metals Translator: Guidance for Calculating a Total Recoverable Limit from a Dissolved Criterion*, EPA Publication 823-B-96-007).

The equivalent total ammonia chronic and acute criteria are 1.24 mg/L and 4.66 mg/L as nitrogen.

(b) *RPA Results*. The SIP methodology was used to perform the RPA and to calculate effluent limitations, because it is consistent with the methodology used to calculate WQBELs for other toxic pollutants. This Order establishes effluent limitations for total ammonia, because the MEC of 24 mg/L exceeds the

applicable water quality criteria for this pollutant, demonstrating reasonable potential by Trigger 1, as defined previously.

- (c) *Total Ammonia WQBELs*. To calculate limits, some statistical adjustments were made because the Basin Plan's chronic objective is based on an annual median instead of a 4-day average. For chronic criterion, the SIP assumes an averaging period of 4 days and a monthly sampling frequency of 4 days per month to calculate effluent limits. To use the SIP methodology to calculate effluent limits for a Basin Plan objective that is based on an annual median, an averaging period of 365 days and a monitoring frequency of 30 days per month (the maximum daily sampling frequency in a month since the averaging period for the chronic criteria is longer than 30 days) were used. These statistical adjustments are supported by U.S. EPA's *Water Quality Criteria; Notice of Availability; 1999 Update of Ambient Water Quality Criteria for Ammonia*; published on December 22, 1999 in the Federal Register.

Following SIP methodology as guidance, the maximum ambient background total ammonia concentration was used to calculate effluent limits based on the acute criterion. For the chronic criterion calculation, the median background total ammonia concentration was used because the Basin Plan's chronic un-ionized ammonia objective is an annual median. Since the time-scale of this objective is over such a long period, it is more representative to use the central tendency of ambient conditions than a daily maximum.

The newly calculated limitations take into account the deep water nature of the discharge and the non-persistent nature of ammonia and, therefore, are based on actual initial dilution.

WQBELs for ammonia calculated according to SIP procedures using a CV of 1.11 and a dilution credit of  $D = 14$  are an AMEL of 26 ug/L and an MDEL of 67 ug/L. The previous permit contained the same limits. This Order retains the effluent limits from the previous permit.

- (d) *Anti-backsliding*. This Order retains the WQBELs from the previous permit, thereby satisfying anti-backsliding requirements.

## 5. Bacteria

- a. *Total Coliform*. This effluent limitation is unchanged from the previous order and is based on the Basin Plan (Chapter 4, Table 4-2A).
- b. *Enterococcus*. The enterococcus effluent limitation is based on the Basin Plan Table 4-2A for all sanitary wastewater discharges to waters with REC1 beneficial uses, which cites the 30-day geometric mean enterococcus bacteria limit based on U.S. EPA criteria established at 40 CFR 131.41. These water quality criteria became effective on December 16, 2004 [69 Fed. Register 67218 (November 16, 2006)]. It is also consistent with the Basin Plan amendment establishing bacteria objectives for waters designated for contact recreation in marine and estuarine waters (Resolution No. R2-2010-0066). The Regional Water Board adopted this amendment on April 14, 2010, the State Water Board approved it on April 5,



2011, the Office of Administrative Law approved it in July 2011, and U.S. EPA approved it on August 16, 2011.

Consistent with the Basin Plan, the Regional Water Board grants in this Order a conservative initial dilution of 10:1 in the calculation of WQBELs for enterococcus. To establish background conditions, the Discharger collected five receiving water samples near its outfall for enterococci from April 2014 through May 2014. These five samples result in a geometric mean of 11.47 MPN/100 mL.

Chapter 4 of the Basin Plan states that effluent limitations in Table 4-2A may be adjusted to account for dilution in a manner consistent with procedures in the SIP. Since bacteria are not persistent and will quickly disperse and degrade, this Order uses the estimated minimum initial dilution ratio of 15:1 (D=14). The enterococcus effluent limitations were calculated, as specified in SIP Section 1.4, using the equation  $ECA = C + D(C - B)$ , where C is the WQO of 35 MPN/100 mL, D is the dilution (D = 14), and B is the background concentration set equal to 11.47 MPN/100 mL (the geometric mean identified from the Discharger's receiving water samples). This results in a five-sample geometric mean limitation for enterococcus of 364 MPN/100 mL.

## 6. Selenium Mass limit

SIP section 2.1.1 states that for bioaccumulative compounds on the 303(d) list, the Regional Water Board should consider whether mass-loading limits should be limited to current levels. The Regional Water Board finds that mass-loading limits are warranted for selenium. The purpose of this mass-loading limit is to further ensure that the Discharger maintains its existing selenium treatment performance and does not further contribute to impairment of the narrative objective for bioaccumulation in Suisun Bay, pending a TMDL.

The mass emission limit is based on the average monthly effluent limitation (calculated above) and the long-term average daily effluent flows (as reported in the Report of Waste Discharge). The mass loading limit is calculated using the average monthly effluent limitation, instead of the maximum daily effluent limitation, because the average monthly effluent limitation better represents long-term performance.

The mass loading limit is calculated using the following equation:

$$\begin{aligned} \text{Mass Emission (kg/day)} &= (\text{Flow, MGD}) \times (\text{Selenium Concentration, mg/L}) \times 3.785 \\ \text{Mass Emission (kg/day)} &= 4.4 \text{ MGD} \times 0.039 \text{ mg/L} \times 3.785 = 0.65 \text{ kg/day} \end{aligned}$$

The existing mass emission limitation imposed under Order No. R2-2010-0084 for selenium is 0.45 kg/day as a running annual average. Because the mass emission limit was more stringent under the previous permit, this Order retains a mass emission limit of 0.45 kg/day.

The mass emission limit is expressed as a running annual average to be consistent with the limit in the previous permit. The running annual average is the arithmetic average of the current day's mass load and the mass loads for each of the previous 364 days, as shown in the following example:

$$\text{Annual Mass emission rate (kg/day)} = \frac{3.785}{N} \sum_{i=1}^N Q_i C_i$$

where:

N = number of samples in a year

Q<sub>i</sub> = flow rate (MGD) associated with the I<sup>th</sup> sample, valid until a new sample is collected

C<sub>i</sub> = selenium concentration (mg/L) associated with the I<sup>th</sup> sample, valid until a new sample is collected

Flow (MGD) = Average of monthly plant effluent flows.

Anti-backsliding requirements are satisfied because the mass-loading limit in this Order is the same as the mass-loading limit in the previous permit.

## 7. Whole Effluent Acute Toxicity

This Order includes effluent limitations for whole effluent acute toxicity based on Basin Plan Table 4-3. All bioassays are to be performed according to the U.S. EPA-approved method in 40 C.F.R. section 136, currently *Methods for Measuring the Acute Toxicity of Effluents and Receiving Waters to Freshwater and Marine Organisms*, 5<sup>th</sup> Edition (EPA-821-R-02-012). The approved test species specified in the MRP is rainbow trout (*Onchorhynchus mykiss*).

Based on Basin Plan section 3.3.20, if the Discharger can demonstrate that ammonia causes acute toxicity in excess of the acute toxicity limitations in this Order, and that the ammonia in the discharge complies with the ammonia effluent limitations in this Order, then such toxicity does not constitute a violation of the effluent limitations for whole effluent acute toxicity.

## 8. Whole Effluent Chronic Toxicity

- a. **Water Quality Objective.** Basin Plan section 3.3.18 states, “There shall be no chronic toxicity in ambient waters. Chronic toxicity is a detrimental biological effect on growth rate, reproduction, fertilization success, larval development, population abundance, community composition, or any other relevant measure of the health of an organism, population, or community.”
- b. **Requirements.** The permit requirements for chronic toxicity are also consistent with the CTR and SIP requirements. This Order includes effluent limitations for chronic toxicity that are more stringent than the previous permit and based on Basin Plan section 4.5.5.3.2. The permit requirements for chronic toxicity are also consistent with the CTR and SIP section 4, Toxicity Control Provisions.

Applying the Basin Plan’s narrative toxicity objective of “...no chronic toxicity in ambient waters” to be equivalent to 1 TU<sub>c</sub>, and the steady state mass balance equation yields the following:

$$C_e = C_o + D(C_o - C_b)$$

where C<sub>e</sub> = the effluent limitation, C<sub>o</sub> = the water quality criteria of 1.0 TU<sub>c</sub>, D = dilution credit (D=9 for 10:1), and C<sub>b</sub> = background- 0 TU<sub>c</sub>. Filling in the variables leads to the following:

$$C_e = 1.0 + 9(1-0)$$

$$C_e = 10 \text{ TU}_c$$

This single sample maximum limit of 10 TU<sub>c</sub> is more stringent than the limits from the previous permit (three sample median of 10 TU<sub>c</sub> and single sample maximum of 20 TU<sub>c</sub>) and necessary to be protective of water quality. Further, the Discharger's data from the past five years show that it can comply with a single sample maximum limit set at 10 TU<sub>c</sub> using mysid shrimp as the test species.

- c. **Screening Phase Study.** The MRP requires the Discharger to conduct a chronic toxicity screening phase study, as described in MRP Appendix E-1, prior to permit reissuance. The Discharger's August 4, 2014, final chronic toxicity screening report indicated that mysid shrimp (*Americamysis bahia*) continues to be the most sensitive species.

## 9. Effluent Limitation Adjustments for Recycled Water Use

This Order provides the Discharger with a process for effluent limitation adjustments for recycled water use to encourage wastewater recycling, consistent with Basin Plan section 4.16 and State Water Board Resolution Nos. 77-1 and 2009-0011, by accounting for increase in pollutant concentrations that may result.

## D. Effluent Limitation Considerations

1. **Anti-backsliding.** This Order complies with the anti-backsliding provisions of CWA sections 402(o) and 303(d)(4) and 40 C.F.R. section 122.44(l), which generally require effluent limitations in a reissued permit to be as stringent as those in the previous permit. The requirements of this Order are at least as stringent as those in the previous permit with the exception of water quality-based copper limits. The copper limits in this Order are less stringent than those in the previous permit because they were calculated based on SSOs, for which an antidegradation analysis consistent with State and federal antidegradation policies was conducted. CWA section 303(d)(4)(B) allows effluent limits to be revised for water bodies that meet water quality standards if such revisions are consistent with antidegradation policies. Suisun Bay meets its copper WQOs, and the SSOs were designed to be protective of beneficial uses.
2. **Antidegradation.** This Order complies with the antidegradation provisions of 40 C.F.R. section 131.12 and State Water Board Resolution No. 68-16. It continues the status quo with respect to the level of discharge authorized in the previous permit, which is the baseline by which to measure whether degradation will occur. This Order does not allow for an increase in flow, or a reduced level of treatment, or less stringent effluent limitations relative to those in the previous permit with the exception of copper. The copper limits are consistent with State and federal antidegradation policies. The antidegradation analysis in the copper SSO concluded that there will be no degradation because dischargers will maintain existing treatment and will be required to implement copper action plans. The increased copper limits implement the SSOs and will not result in a lowering of water quality as set forth in the antidegradation analysis. This is because this Order does not allow for a reduced level of treatment and requires the Discharger to implement a Copper Action Plan. Therefore, the limits are consistent with antidegradation.

**3. Stringency of Requirements for Individual Pollutants.** This Order contains both technology-based and WQBELs for individual pollutants. The technology-based mass limitations are consistent with applicable statutes and regulations. They are derived from the applicable effluent guidelines for cracking refineries based on Effluent Limitations Guidelines for the Petroleum Refining Point Source Category (40 CFR 419) and represent Best Practicable Control Technology (BPT) and Best Conventional Pollutant Control Technology (BCT). They therefore represent the best practicable treatment or control available. Carquinez Strait meets water quality standards for all pollutants subject to the technology-based mass limits in this Order, and no increase in pollutant loading is likely. The new limits are therefore consistent with federal and State antidegradation policies. In addition, this Order contains more stringent effluent limitations as necessary to meet water quality standards. Collectively, this Order's restrictions on individual pollutants are no more stringent than required to implement CWA requirements.

This Order's WQBELs have been derived to implement WQOs that protect beneficial uses. The beneficial uses and WQOs have been approved pursuant to federal law and are the applicable federal water quality standards. To the extent that WQBELs were derived from the CTR, the CTR is the applicable standard pursuant to 40 C.F.R. section 131.38. The procedures for calculating these WQBELs are based on the CTR, as implemented in accordance with the SIP, which U.S. EPA approved on May 18, 2000. U.S. EPA approved most Basin Plan beneficial uses and WQOs prior to May 30, 2000. Beneficial uses and WQOs submitted to U.S. EPA prior to May 30, 2000, but not approved by U.S. EPA before that date, are nonetheless "applicable water quality standards for purposes of the CWA" pursuant to 40 C.F.R. section 131.21(c)(1). U.S. EPA approved the remaining beneficial uses and WQOs so they are applicable water quality standards pursuant to 40 C.F.R. section 131.21(c)(2).

## **V. RATIONALE FOR RECEIVING WATER LIMITATIONS**

The receiving water limitations in sections V.A and V.B of the Order are based on Basin Plan narrative and numeric WQOs. The receiving water limitation in section V.C of the Order requires compliance with federal and State water quality standards in accordance with the CWA and regulations adopted thereunder.

## **VI. RATIONALE FOR PROVISIONS**

### **A. Standard Provisions**

Attachment D contains standard provisions that apply to all NPDES permits in accordance with 40 C.F.R. section 122.41 and additional conditions applicable to specific categories of permits in accordance with 40 C.F.R. section 122.42. The Discharger must comply with these provisions. The conditions set forth in 40 C.F.R. sections 122.41(a)(1) and (b) through (n) apply to all state-issued NPDES permits and must be incorporated into the permits either expressly or by reference.

In accordance with 40 C.F.R. section 123.25(a)(12), states may omit or modify conditions to impose more stringent requirements. Attachment G contains standard provisions that supplement the federal standard provisions in Attachment D. This Order omits federal conditions that address enforcement authority specified in 40 C.F.R. sections 122.41(j)(5) and (k)(2) because the State's

enforcement authority under the Water Code is more stringent. In lieu of these conditions, this Order incorporates Water Code section 13387(e) by reference.

## **B. Monitoring and Reporting**

Pursuant to 40 C.F.R. section 122.48, NPDES permits must specify requirements for recording and reporting monitoring results. Water Code sections 13267 and 13383, and 40 C.F.R. sections 122.41(h) and (j), authorize the Regional Water Board to require technical and monitoring reports. This Order establishes monitoring and reporting requirements, contained in the Monitoring and Reporting Program (Attachment E) that implement federal and State requirements. For more background regarding these requirements, see Fact Sheet section VII.

## **C. Special Provisions**

### **1. Reopener Provisions**

These provisions are based on 40 C.F.R. sections 122.62 and 122.63 and allow modification of this Order and its effluent limitations as necessary in response to updated WQOs, regulations, or other new and relevant information that may become available in the future, and other circumstances as allowed by law.

### **2. Effluent Characterization Study and Report**

This Order does not include effluent limitations for priority pollutants that do not demonstrate reasonable potential, but this provision requires the Discharger to continue monitoring for these pollutants as described in the MRP and Attachment G. Monitoring data are necessary to verify that the “no” and “unknown” reasonable potential analysis conclusions of this Order remain valid. This requirement is authorized pursuant to Water Code section 13267 and is necessary to inform the next permit reissuance and to ensure that the Discharger takes timely steps in response to any unanticipated change in effluent quality during the term of this Order.

### **3. Pollutant Minimization Program**

This provision is based on Basin Plan section 4.13.2 and SIP section 2.4.5.

### **4. Other Special Provisions**

- a. **Copper Action Plan.** This provision is based on Basin Plan section 7.2.1.2. It is necessary to ensure that use of copper site-specific objectives is consistent with antidegradation policies. Data the San Francisco Estuary Institute compiled for 2009-2011 indicate no degradation of San Francisco Bay water quality with respect to copper (<http://www.sfei.org/content/copper-site-specific-objective-3-year-rolling-averages>).
- b. **Cyanide Action Plan.** This provision is based on Basin Plan section 4.7.2.2. It is necessary to ensure that use of cyanide site-specific objectives is consistent with antidegradation policies.

- c. **Stormwater Pollution Prevention Plan and Annual Report.** This provision is based on Basin Plan section 4.8, statewide stormwater requirements for industrial facilities, and applicable U.S. EPA regulations. It is retained from the previous permit. To be consistent with the California State Lands Commission Final Environmental Impact Report, dated January 30, 2015, for the Tesoro Avon Marine Oil Terminal Lease Consideration Project, this provision requires the Discharger to update best management practices for the Avon Wharf. To ensure that solids are controlled with appropriate best management practices, this provision also requires the Discharger to install, and to certify installation of, underground settlement collection vaults at two locations that have consistently discharged high TSS values.
- d. **Construction and Development Requirements for Stormwater.** This provision is to clarify when the Discharger must apply for coverage under the *NPDES General Permit for Stormwater Discharges Associated with Construction and Land Disturbance Activities*, Order No. 2009-0009-DWQ.
- e. **Conditions for Mass and Concentration Adjustments for Recycled Water.** This provision is necessary to protect beneficial uses identified in the Basin Plan (the Discharger must ensure that granting it pollutant adjustments for the use of recycled water will not cause toxicity).

## VII. RATIONALE FOR MONITORING AND REPORTING PROGRAM (MRP)

CWA section 308 and 40 C.F.R. sections 122.41(h), 122.41(j)-(l), 122.44(i), and 122.48 require that NPDES permits specify monitoring and reporting requirements. Water Code sections 13267 and 13383 also authorize the Regional Water Board to establish monitoring, inspection, entry, reporting, and recordkeeping requirements. The Monitoring and Reporting Program (Attachment E) of this Order establishes monitoring, reporting, and recordkeeping requirements that implement federal and State requirements. The following provides the rationale for the MRP requirements:

### A. MRP Requirements Rationale

1. **Influent Monitoring.** This Order does not require the Discharger to conduct monitoring of Facility influent. However, the Discharger has the option of using recycled water in exchange for adjustments, in which case the Discharger will need to conduct monitoring at INF-001 and INF-002.
2. **Effluent Monitoring.** Effluent flow monitoring is necessary to understand Facility operations. Monitoring for the other parameters in MRP Table E-3 is necessary to evaluate compliance with this Order's effluent limitations.
3. **Whole Effluent Toxicity Testing.** Acute and chronic whole effluent toxicity tests are necessary to evaluate compliance with the acute and chronic toxicity effluent limitations. Chronic toxicity tests are also necessary to evaluate whether chronic toxicity triggers the need for a TRE.
4. **Receiving Water Monitoring.** The Discharger is required to continue participating in the RMP, which involves collecting data on pollutants and toxicity in San Francisco Bay water,

sediment, and biota. This monitoring is necessary to characterize the receiving water and the effects of the discharges this Order authorizes.

**B. Monitoring Requirements Summary.** The table below summarizes routine monitoring requirements. This table is for informational purposes only. The actual requirements are specified in the MRP and elsewhere in this Order.

Parameter	Influent INF-001 & INF-002	Effluent EFF-001	Effluent EFF-001-D1 & EFF-002-D2	Effluent EFF-003 thru 006	Receiving Water
Flow	{1}	Cont			
pH		Cont		Each discharge {2}	
Temperature		Cont			
COD		1/Month		Each discharge {3}	
BOD <sub>5</sub>		1/Month		Each discharge {3}	
TSS		1/Week		Each discharge {2}	
Specific conductance				Each discharge {2}	
Total Organic Carbon				Each discharge {2}	
Oil and Grease		1/Week		Each discharge {2}	
Phenolic Compounds		1/Month		Each discharge {3}	
Chromium, Total and VI		1/Month		Each discharge {3}	
Sulfide		1/Month			
Ammonia total as N	{1}	1/Month			
Total Coliformn			1/Week		
Enterococci			1/Month		
Acute Toxicity		1/Week			Support RMP
Chronic Toxicity		1/Quarter			Support RMP
Copper	{1}	1/Month			Support RMP
Lead	{1}	1/Month			Support RMP
Selenium	{1}	1/Week			Support RMP
Cyanide	{1}	1/Month			Support RMP
Dioxins and Furans	{1}	2/Year			Support RMP
All other priority pollutants		2/Year			Support RMP
Standard Observations				Each discharge {2}	

{1}For discharge limit adjustments only.

{2}For E-005and E-006, the minimum sampling frequency is twice per year.

{3}If and when supplemental effluent limitations in Table 9 of this Order become effective, the monitoring frequency for stormwater impoundments (i.e., E-003 and E-004) shall be during each discharge event while the monitoring frequency for E-005 and E-006 shall be daily during each storm event.

## VIII. PUBLIC PARTICIPATION

The Regional Water Board considered the issuance of WDRs that will serve as an NPDES permit for the Facility. As a step in the WDR adoption process, Regional Water Board staff developed tentative WDRs and encouraged public participation in the WDR adoption process.

**A. Notification of Interested Parties.** The Regional Water Board notified the Discharger and interested agencies and persons of its intent to prescribe WDRs for the discharge and provided an opportunity to submit written comments and recommendations. Notification was provided through *The Martinez News Gazette*. The public had access to the agenda and any changes in dates and locations through the Regional Water Board's website at <http://www.waterboards.ca.gov/sanfranciscobay>.

**B. Written Comments.** Interested persons were invited to submit written comments concerning the tentative WDRs as explained through the notification process. Comments were to be submitted either in person or by mail to the Executive Office at the Regional Water Board at 1515 Clay Street, Suite 1400, Oakland, California 94612, to the attention of Robert Schlipf.

For full staff response and Regional Water Board consideration, the written comments were due at the Regional Water Board office by 5:00 p.m. on June 8, 2015.

**C. Public Hearing.** The Regional Water Board held a public hearing on the tentative WDRs during its regular meeting at the following date and time, and at the following location:

Date: **July 8, 2015**  
Time: 9:00 am  
Location: Elihu Harris State Office Building  
1515 Clay Street, 1<sup>st</sup> Floor Auditorium  
Oakland, CA 94612

Contact: Robert Schlipf, (510) 622-2478, [Robert.Schlipf@waterboards.ca.gov](mailto:Robert.Schlipf@waterboards.ca.gov)

Interested persons were invited to attend. At the public hearing, the Regional Water Board heard testimony pertinent to the discharge, WDRs, and permit. For accuracy of the record, important testimony was requested to be in writing.

Dates and venues change. The Regional Water Board web address is <http://www.waterboards.ca.gov/sanfranciscobay>, where one could access the current agenda for changes in dates and locations.

**D. Reconsideration of Waste Discharge Requirements.** Any aggrieved person may petition the State Water Board to review the Regional Water Board decision regarding the final WDRs. The State Water Board must receive the petition at the following address within 30 calendar days of the Regional Water Board action:

State Water Resources Control Board  
Office of Chief Counsel  
P.O. Box 100, 1001 I Street  
Sacramento, CA 95812-0100

For instructions on how to file a petition for review, see [http://www.waterboards.ca.gov/public\\_notices/petitions/water\\_quality/wqpetition\\_instr.shtml](http://www.waterboards.ca.gov/public_notices/petitions/water_quality/wqpetition_instr.shtml).

**E. Information and Copying.** The Report of Waste Discharge, related supporting documents, and comments received are on file and may be inspected at the address above at any time between



9:00 a.m. and 5:00 p.m., Monday through Friday. Copying of documents may be arranged by calling (510) 622-2300.

- F. Register of Interested Persons.** Any person interested in being placed on the mailing list for information regarding the WDRs and NPDES permit should contact the Regional Water Board, reference the Facility, and provide a name, address, and phone number.
- G. Additional Information.** Requests for additional information or questions regarding this Order should be directed to Robert Schlipf, at (510) 622-2478 or [Robert.Schlipf@waterboards.ca.gov](mailto:Robert.Schlipf@waterboards.ca.gov).

## ATTACHMENT F-1

### Derivation of Technology-Based Effluent Limitations Tesoro Martinez Refinery

#### **References**

1. 40 CFR 419 Subpart B – Cracking Subcategory, *Effluent Limitation Guidelines and New Source Performance Standards for the Petroleum Refining Point Source Category* (2006)
2. *Development Document for Effluent Limitations Guidelines and New Source Performance Standards for the Petroleum Refining Point Source Category*, EPA/4401-82/014 (1982)
3. *Guide for the Application of Effluent Limitations Guidelines for the Petroleum Refining Industry*, U.S. EPA Office of Water Regulations and Standards (1985)
4. Tesoro Martinez Refinery, NPDES Application for Permit Renewal, NPDES Permit No. CA0004961 (December 30, 2014, revised February 3, 2015)
5. Refinery Production Data from NPDES Application for Permit Renewal, Attachment 2C-IIIC – Basis for Reporting Production Rates

#### **Applicable Definitions**

*Process Wastewater* means any water, which, during manufacturing or processing, comes into direct contact with or results from the production or use of any raw material, intermediate product, finished product, byproduct, or waste product. [40 CFR 401.11(q)]

*Runoff* means the flow of stormwater resulting from precipitation coming into contact with petroleum refinery property. [40 CFR 419.11(b)]

*Contaminated Runoff* means runoff that comes into contact with any raw material, intermediate product, finished product, by-product or waste product located on petroleum refinery property. [40 CFR 419.11(g)]

#### **Background**

Effluent Limitations Guidelines (ELGs) for the Cracking Subcategory of the Petroleum Refining Point Source Category at 40 CFR 419 Subpart B are based, in part, on a discharger's production rate. The Discharger's current maximum production rate is 143,600 barrels per day (bbls/d).

*Process Wastewaters.* The ELGs include limitations for process wastewaters based on best practicable control technology currently available (BPT), best available technology economically achievable (BAT), and best conventional pollutant control technology (BCT). Specific BPT, BAT, and BCT effluent limitations that apply to the Discharger must be derived using methods described by the ELGs and take into account such factors as production rate, as well as refinery processes and configuration. The most stringent of BPT, BAT, and BCT limitations apply.

For derivation of BPT, BAT, and BCT limitations for process wastewaters, size factors and process factors are determined as follows:

**Size Factor.** At a crude processing rate of 143,600 bbls/d, the appropriate size factors, pursuant to the ELGs at 40 CFR 419.22(b)(1) for BPT, at 40 CFR 419.23(b)(1) for BAT, and at 40 CFR 419.24(b)(1) for BCT, for derivation of technology-based effluent limitations is 1.35.

**Process Factor.** The process configuration for each process is determined by summing the process feedstock rates for each crude, cracking and coking, lube, and asphalt process at the refinery. Each individual feedstock rate is multiplied by the capacity relative to the throughput, and a weight factor specific for each process, to derive a “process configuration,” which in turn is used to determine a “process factor” in accordance with the ELGs at 40 CFR 419.22(b) (2) for BPT, at 40 CFR 419.23(b)(2) for BAT, and at 40 CFR 419.24(b)(2) for BCT.

Processes considered in deriving the process factors are those processes within the crude and cracking and coking categories as reported by the Discharger, which correspond to the process groups listed within the *Guide for the Application of Effluent Limitations Guidelines for the Petroleum Refining Industry* (page 19). The Discharger does not include lube processes, so this process group is not considered in determining process factors.

Derivation of the process configuration for a production rate of 143,600 bbls/d is shown in the following table:

**Table F-1A. Process Configurations**

<b>Production at 143,600 bbls/day</b>				
<b>Process</b>	<b>Process Feedstock Rate <sup>A</sup></b>	<b>Process/ Feedstock Ratio</b>	<b>Weight Factor</b>	<b>Process Configuration</b>
<b>Crude</b>				
Atm. Dist.	143.6	1.0		
Vac. Dist.	106.8	0.744		
Desalt.	143.6	1.0		
Total	394	2.744	1	2.74
<b>Cracking</b>				
Catalytic Cracking	64.0	0.446		
Hydrocracking	31.1	0.216		
Hydrotreating	151.2	1.053		
Coking	44.7	0.311		
Total	283.4	2.026	6	12.16
<b>Lube</b>	---	---	13	---
<b>Total Refinery Configuration at 143,600 bbls/day</b>				<b>14.9</b>

In accordance with 40 CFR 419.22(b)(2) for BPT, 40 CFR 419.232(b)(2) for BAT, 40 CFR 419.22(b)(2) for BCT, the process factor is 1.89

To determine BAT limitations for total and hexavalent chromium and phenolic compounds in process wastewaters, the ELGs require consideration of effluent factors and refinery processes. BAT effluent factors are presented at 40 CFR 419.23(c)(1); the refinery processes considered are the crude, cracking and coking, and reforming and alkylation processes, which correspond to those identified within the *Guide for the Application of Effluent Limitations Guidelines for the Petroleum Refining Industry* (page 20).

Contaminated Runoff. The ELGs establish BPT, BAT, and BCT limitations for contaminated runoff, which apply to all stormwater discharges, except stormwater treated and discharged with process wastewaters through Discharge Point 001. ELGs establish effluent limitations for oil and grease and total organic carbon (TOC), and then, if limitations for oil and grease or TOC are exceeded, additional limitations for BOD, COD, TSS, phenolic compounds, pH, and hexavalent and total chromium, found at 40 CFR 419.22(e)(2) and 419.23(f)(2), become effective.

In general, BPT limitations are the most comprehensive and stringent of all applicable technology-based limitations for contaminated runoff and, therefore, are incorporated into this Order as additional effluent limitations for discharges of contaminated runoff where oil and grease or TOC limits are exceeded. The following table summarizes the applicable technology-based effluent limitations, established by the ELGs, for contaminated runoff:

**Table F-1B. Contaminated Runoff Technology-Based Limitations**

Pollutant		Effluent Limitation <sup>A</sup>	
	Max Daily (mg/L)	30-day Average <sup>B</sup> (mg/L)	
Oil and Grease	15	---	
TOC	110	---	
pH	6.0 – 9.0 (s.u.)		
If either limitation for oil and grease or TOC, above, is exceeded, then the following limitations shall become effective			
BOD <sub>5</sub>	48	26	
TSS	33	21	
COD	360	180	
Oil and Grease	15	8.0	
Phenolic Compounds (4AAP)	0.35	0.17	
Total Chromium	0.60	0.21	
Hexavalent Chromium	0.062	0.028	

The Order establishes effluent limitations for oil and grease and TOC for all discharge points where contaminated runoff is discharged. Effluent limitations for BOD, TSS, COD, phenolics, and chromium will become effective immediately upon an exceedance of oil and grease or TOC for the outfall where the exceedance occurred. The effluent limit for pH listed in the table above is not imposed by this permit. The previous permit established a pH limit of 6.5 to 8.5, consistent with Basin Plan Table 4-2 for shallow-water discharges. This limit is retained by this Order to satisfy anti-backsliding requirements.

***Determination of Process Wastewater Effluent Limitations***

BPT. The following table shows the derivation of process wastewater BPT limitations at a production rate of 143,600 bbls/day:

**Table F-1C. BPT Limitations for Process Wastewaters**

	Preliminary Effluent Limitation Factor <sup>A</sup>		Size Factor	Process Factor	Feed Stock Rate	Effluent Limitation <sup>B</sup>	
	Max Daily	Avg Monthly				Max Daily	Avg Monthly
<b>Production at 143,600 bbls/d</b>							
BOD <sub>5</sub>	9.9	5.5	1.35	1.89	143.6	3627	2015
TSS	6.9	4.4	1.35	1.89	143.6	2528	1612

	Preliminary Effluent Limitation Factor <sup>A</sup>		Size Factor	Process Factor	Feed Stock Rate	Effluent Limitation <sup>B</sup>	
	Max Daily	Avg Monthly				Max Daily	Avg Monthly
COD	74.0	38.4	1.35	1.89	143.6	27113	14070
Oil & Grease	3.0	1.6	1.35	1.89	143.6	1099	586
Phenolics (4AAP)	0.074	0.036	1.35	1.89	143.6	27	13
Ammonia (as N)	6.6	3.0	1.35	1.89	143.6	2418	1099
Sulfide	0.065	0.029	1.35	1.89	143.6	24	11
Total Chromium	0.15	0.088	1.35	1.89	143.6	55	32
Hexavalent Chromium	0.012	0.0056	1.35	1.89	143.6	4.4	2.1

<sup>A</sup> From 40 CFR 419.22(a) (pounds per 1000 bbls of feedstock)

<sup>B</sup> Pounds per day (lbs/d)

**BAT.** The following table shows the derivation of BAT limitations for process wastewaters at a production rate of 143,600 bbls/d:

**Table F-1D. Process Wastewater BAT Limitations**

	Preliminary Effluent Limitation Factor <sup>A</sup>		Size Factor	Process Factor	Feed Stock Rate	Effluent Limitation <sup>B</sup>	
	Max Daily	Avg Monthly				Max Daily	Avg Monthly
<b>Production at 143,600 bbls/d</b>							
COD	74.0	38.4	1.35	1.89	143.6	27113	14070
Ammonia (as N)	6.6	3.0	1.35	1.89	143.6	2418	1099
Sulfide	0.065	0.029	1.35	1.89	143.6	24	11

<sup>A</sup> From 40 CFR 419.23(a) (pounds per 1,000 bbls feedstock)

<sup>B</sup> Pounds per day (lbs/d)

BAT limitations for total and hexavalent chromium and phenolic compounds are based on feedstock rates. Figures used in calculations for this Order are shown in the following table:

**Table F-1E. Feedstock Rates for Determining BAT Limitations**

Refinery Throughput	143,600 bbls/d
<b>Crude</b>	
Atmospheric Distillation	143.6
Vacuum Distillation	106.8
Desalter	143.6
<b>Total</b>	<b>394</b>
<b>Cracking and Coking</b>	
Catalytic Cracking	64
Coking	44.7
Hydrocracking	31.1
Hydrotreating	151.2
<b>Total</b>	<b>291</b>

<b>Lube</b>	
<b>Total</b>	---
<b>Reforming and Alkylation <sup>A</sup></b>	
Reforming	21.3
Alkylation	13.2
<b>Total</b>	<b>34.5</b>

Based on the total feedstock rates shown above, derivation of BAT limitations for total and hexavalent chromium and phenolic compounds is shown in the following table:

**Table F-1F. Process Wastewater BAT Limitations (Chromium and Phenolics)**

Pollutant	Preliminary Effluent Limitations Factor <sup>A</sup>		Feedstock Rate	Effluent Limitations <sup>B</sup>	
	Max Daily	Avg Monthly		Max Daily	Avg Monthly
<b>Production at 143,600 bbls/d</b>					
<i>Phenolic Compounds</i>					
Crude	0.013	0.0030	394	5.12	1.18
Cracking and Coking	0.147	0.036	291	42.8	10.48
Reforming and Alkylation	0.132	0.032	34.5	4.55	1.10
<b>Limit (Sum)</b>	---	---	---	<b>52.5</b>	<b>12.8</b>
<i>Total Chromium</i>					
Crude	0.011	0.004	394	4.33	1.58
Cracking and Coking	0.119	0.041	291	34.63	11.93
Reforming and Alkylation	0.107	0.037	34.5	3.69	1.28
<b>Limit (Sum)</b>	---	---	---	<b>42.7</b>	<b>14.8</b>
<i>Hexavalent Chromium</i>					
Crude	0.0007	0.0003	394	0.28	0.12
Cracking and Coking	0.0076	0.0034	291	2.21	0.99
Reforming and Alkylation	0.0069	0.0031	34.5	0.24	0.11
<b>Limit (Sum)</b>	---	---	---	<b>2.73</b>	<b>1.21</b>

<sup>A</sup> From 40 CFR 419.23(c), lbs per 1,000 barrels feedstock

<sup>B</sup> Pounds per day (lbs/d)

BCT. The following table shows the derivation of BCT limitations for process wastewaters at a production rate of 143,600 bbls/d:

**Table F-1G. Process Wastewater BCT Limitations**

Pollutant	Preliminary Effluent Limitations Factor <sup>A</sup>		Size Factor	Process Factor	Feed Stock Rate	Final Effluent Limitations <sup>B</sup>	
	Max Daily	Avg Monthly				Max Daily	Avg Monthly
<b>Production at 143,600 bbls/d</b>							
BOD <sub>5</sub>	9.9	5.5	1.35	1.89	143.6	3627	2015
TSS	6.9	4.4	1.35	1.89	143.6	2528	1612
Oil & Grease	3.0	1.6	1.35	1.89	143.6	1099	586

<sup>A</sup> From 40 CFR 419.24(a), pounds per 1,000 barrels feedstock

<sup>B</sup> Pounds per day (lbs/d)

**Most Stringent Technology-Based Process Wastewater Effluent Limitations**

The following table presents the technology-based process wastewater effluent limitations that apply to the Discharger. The limitations are the most stringent of the BPT, BAT, and BCT limitations required by the ELGs and are expressed in units of lbs/day based on a production rate of 143,600 bbls/d.

**Table F-1H. Summary of Technology-Based Process Wastewater Effluent Limitations**

Pollutant	Effluent Limitations <sup>A, B</sup>	
	Max Daily	Avg Monthly
<b>Production at 143,600 bbls/d</b>		
BOD <sub>5</sub>	3,627	2,015
TSS	2,528	1,612
COD	27,113	14,070
Oil & Grease	1,099	586
Phenolics (4AAP)	27	13
Ammonia (as N)	2,418	1,099
Sulfide	24	11
Total Cr	43 <sup>C</sup>	15 <sup>C</sup>
Hex Cr	2.7 <sup>C</sup>	1.2 <sup>C</sup>

<sup>A</sup> Units are lbs/day

<sup>B</sup> All technology-based limitations for process wastewaters are based on BPT unless otherwise noted.

<sup>C</sup> Based on BAT

**Determination of Effluent Limitations for Contaminated Runoff**

If contaminated stormwater discharges exceed the oil and grease limit (15 mg/L) or the total organic carbon limit (110 mg/L), additional concentration-based limitations for BOD<sub>5</sub>, TSS, COD, phenolics, total chromium, hexavalent chromium, and pH become immediately effective. The effluent limitations for these pollutants are derived from the most stringent of the BCT, BAT, and BPT effluent concentration-based limitations provided in the ELGs. A table summarizing these additional effluent limitations is below:

**Table F-1I. Additional Stormwater Effluent Limitations**

Pollutant	Daily Maximum (mg/L)	30 Day Average (mg/L)
BOD <sub>5</sub>	48	26
TSS	33	21
COD	360	180
Oil and Grease	15	8.0
Phenolic Compounds	0.35	0.17
Total Chromium	0.60	0.21
Hexavalent Chromium	0.062	0.028

**CALIFORNIA REGIONAL WATER QUALITY CONTROL BOARD  
SAN FRANCISCO BAY REGION**

**ATTACHMENT G  
REGIONAL STANDARD PROVISIONS, AND MONITORING  
AND REPORTING REQUIREMENTS  
(SUPPLEMENT TO ATTACHMENT D)**

For

**NPDES WASTEWATER DISCHARGE PERMITS**

March 2010



## Contents

<b>I. STANDARD PROVISIONS - PERMIT COMPLIANCE.....</b>	<b>G-1</b>
A. Duty to Comply .....	G-1
B. Need to Halt or Reduce Activity Not a Defense .....	G-1
C. Duty to Mitigate .....	G-1
1. Contingency Plan .....	G-1
2. Spill Prevention Plan.....	G-2
D. Proper Operation & Maintenance.....	G-2
1. Operation and Maintenance (O&M) Manual.....	G-2
2. Wastewater Facilities Status Report .....	G-2
3. Proper Supervision and Operation of Publicly Owned Treatment Works (POTWs) .....	G-3
E. Property Rights.....	G-3
F. Inspection and Entry.....	G-3
G. Bypass .....	G-3
H. Upset.....	G-3
I. Other .....	G-3
J. Storm water .....	G-3
1. Storm water Pollution Prevention Plan (SWPP Plan).....	G-3
2. Source Identification.....	G-4
3. Storm water Management Controls .....	G-5
4. Annual Verification of SWPP Plan.....	G-6
K. Biosolids Management .....	G-6
<b>II. STANDARD PROVISIONS – PERMIT ACTION.....</b>	<b>G-7</b>
<b>III. STANDARD PROVISIONS – MONITORING .....</b>	<b>G-7</b>
A. Sampling and Analyses .....	G-7
1. Use of Certified Laboratories.....	G-7
2. Use of Appropriate Minimum Levels .....	G-7
3. Frequency of Monitoring .....	G-7
B. Biosolids Monitoring.....	G-10
1. Biosolids Monitoring Frequency .....	G-10
2. Biosolids Pollutants to Monitor .....	G-10
C. Standard Observations.....	G-10
1. Receiving Water Observations .....	G-10
2. Wastewater Effluent Observations .....	G-11
3. Beach and Shoreline Observations .....	G-11
4. Land Retention or Disposal Area Observations.....	G-11
5. Periphery of Waste Treatment and/or Disposal Facilities Observations .....	G-12
<b>IV. STANDARD PROVISIONS – RECORDS .....</b>	<b>G-12</b>
A. Records to be Maintained.....	G-12
B. Records of monitoring information .....	G-12
1. Analytical Information.....	G-12
2. Flow Monitoring Data.....	G-12
3. Wastewater Treatment Process Solids .....	G-13
4. Disinfection Process.....	G-13
5. Treatment Process Bypasses .....	G-13
6. Treatment Facility Overflows .....	G-14
C. Claims of Confidentiality .....	G-14
<b>V. STANDARD PROVISIONS – REPORTING .....</b>	<b>G-14</b>
A. Duty to Provide Information .....	G-14

B. Signatory and Certification Requirements .....	G-14
C. Monitoring Reports .....	G-14
1. Self Monitoring Reports .....	G-14
D. Compliance Schedules .....	G-18
E. Twenty-Four Hour Reporting .....	G-18
1. Spill of Oil or Other Hazardous Material Reports .....	G-18
2. Unauthorized Discharges from Municipal Wastewater Treatment Plants .....	G-19
F. Planned Changes .....	G-22
G. Anticipated Noncompliance .....	G-22
H. Other Noncompliance.....	G-22
I. Other Information.....	G-22
<b>VI. STANDARD PROVISION – ENFORCEMENT .....</b>	<b>G-22</b>
<b>VII. ADDITIONAL PROVISIONS – NOTIFICATION LEVELS .....</b>	<b>G-22</b>
<b>VIII. DEFINITIONS .....</b>	<b>G-22</b>

**CALIFORNIA REGIONAL WATER QUALITY CONTROL BOARD  
SAN FRANCISCO BAY REGION**

**REGIONAL STANDARD PROVISIONS, AND MONITORING AND  
REPORTING REQUIREMENTS  
(SUPPLEMENT TO ATTACHMENT D)**

**FOR**

**NPDES WASTEWATER DISCHARGE PERMITS**

**APPLICABILITY**

This document applies to dischargers covered by a National Pollutant Discharge Elimination System (NPDES) permit. This document does not apply to Municipal Separate Storm Sewer System (MS4) NPDES permits.

The purpose of this document is to supplement the requirements of Attachment D, Standard Provisions. The requirements in this supplemental document are designed to ensure permit compliance through preventative planning, monitoring, recordkeeping, and reporting. In addition, this document requires proper characterization of issues as they arise, and timely and full responses to problems encountered. To provide clarity on which sections of Attachment D this document supplements, this document is arranged in the same format as Attachment D.

**I. STANDARD PROVISIONS - PERMIT COMPLIANCE**

**A. Duty to Comply** – Not Supplemented

**B. Need to Halt or Reduce Activity Not a Defense** – Not Supplemented

**C. Duty to Mitigate** – This supplements I.C. of Standard Provisions (Attachment D)

- 1. Contingency Plan** - The Discharger shall maintain a Contingency Plan as originally required by Regional Water Board Resolution 74-10 and as prudent in accordance with current municipal facility emergency planning. The Contingency Plan shall describe procedures to ensure that existing facilities remain in, or are rapidly returned to, operation in the event of a process failure or emergency incident, such as employee strike, strike by suppliers of chemicals or maintenance services, power outage, vandalism, earthquake, or fire. The Discharger may combine the Contingency Plan and Spill Prevention Plan into one document. Discharge in violation of the permit where the Discharger has failed to develop and implement a Contingency Plan as described below will be the basis for considering the discharge a willful and negligent violation of the permit pursuant to California Water Code Section 13387. The Contingency Plan shall, at a minimum, contain the provisions of a. through g. below.
  - a. Provision of personnel for continued operation and maintenance of sewerage facilities during employee strikes or strikes against contractors providing services.

- b. Maintenance of adequate chemicals or other supplies and spare parts necessary for continued operations of sewerage facilities.
  - c. Provisions of emergency standby power.
  - d. Protection against vandalism.
  - e. Expeditious action to repair failures of, or damage to, equipment and sewer lines.
  - f. Report of spills and discharges of untreated or inadequately treated wastes, including measures taken to clean up the effects of such discharges.
  - g. Programs for maintenance, replacement, and surveillance of physical condition of equipment, facilities, and sewer lines.
2. **Spill Prevention Plan** - The Discharger shall maintain a Spill Prevention Plan to prevent accidental discharges and minimize the effects of such events. The Spill Prevention Plan shall:
- a. Identify the possible sources of accidental discharge, untreated or partially treated waste bypass, and polluted drainage;
  - b. Evaluate the effectiveness of present facilities and procedures, and state when they became operational; and
  - c. Predict the effectiveness of the proposed facilities and procedures, and provide an implementation schedule containing interim and final dates when they will be constructed, implemented, or operational.

This Regional Water Board, after review of the Contingency and Spill Prevention Plans or their updated revisions, may establish conditions it deems necessary to control accidental discharges and to minimize the effects of such events. Such conditions may be incorporated as part of the permit upon notice to the Discharger.

**D. Proper Operation & Maintenance** – This supplements I.D of Standard Provisions (Attachment D)

1. **Operation and Maintenance (O&M) Manual** - The Discharger shall maintain an O&M Manual to provide the plant and regulatory personnel with a source of information describing all equipment, recommended operational strategies, process control monitoring, and maintenance activities. To remain a useful and relevant document, the O&M Manual shall be kept updated to reflect significant changes in treatment facility equipment and operational practices. The O&M Manual shall be maintained in usable condition and be available for reference and use by all relevant personnel and Regional Water Board staff.
2. **Wastewater Facilities Status Report** - The Discharger shall regularly review, revise, or update, as necessary, its Wastewater Facilities Status Report. This report shall document how the Discharger operates and maintains its wastewater collection, treatment, and disposal facilities to ensure that all facilities are adequately staffed, supervised, financed, operated, maintained, repaired, and upgraded as necessary to provide adequate and reliable transport, treatment, and disposal of all wastewater from both existing and planned future wastewater sources under the Discharger's service responsibilities.

3. Proper Supervision and Operation of Publicly Owned Treatment Works (POTWs) - POTWs shall be supervised and operated by persons possessing certificates of appropriate grade pursuant to Division 4, Chapter 14, Title 23 of the California Code of Regulations.

**E. Property Rights** – Not Supplemented

**F. Inspection and Entry** – Not Supplemented

**G. Bypass** – Not Supplemented

**H. Upset** – Not Supplemented

**I. Other** – This section is an addition to Standard Provisions (Attachment D)

1. Neither the treatment nor the discharge of pollutants shall create pollution, contamination, or nuisance as defined by California Water Code Section 13050.
2. Collection, treatment, storage, and disposal systems shall be operated in a manner that precludes public contact with wastewater, except in cases where excluding the public is infeasible, such as private property. If public contact with wastewater could reasonably occur on public property, warning signs shall be posted.
3. If the Discharger submits a timely and complete Report of Waste Discharge for permit reissuance, this permit continues in force and effect until a new permit is issued or the Regional Water Board rescinds the permit.

**J. Storm Water** – This section is an addition to Standard Provisions (Attachment D)

These provisions apply to facilities that do not direct all storm water flows from the facility to the wastewater treatment plant headworks.

**1. Storm Water Pollution Prevention Plan (SWPP Plan)**

The SWPP Plan shall be designed in accordance with good engineering practices and shall address the following objectives:

- a. To identify pollutant sources that may affect the quality of storm water discharges; and
- b. To identify, assign, and implement control measures and management practices to reduce pollutants in storm water discharges.

The SWPP Plan may be combined with the existing Spill Prevention Plan as required in accordance with Section C.2. The SWPP Plan shall be retained on-site and made available upon request of a representative of the Regional Water Board.

## 2. Source Identification

The SWPP Plan shall provide a description of potential sources that may be expected to add significant quantities of pollutants to storm water discharges, or may result in non-storm water discharges from the facility. The SWPP Plan shall include, at a minimum, the following items:

- a. A topographical map (or other acceptable map if a topographical map is unavailable), extending one-quarter mile beyond the property boundaries of the facility, showing the wastewater treatment facility process areas, surface water bodies (including springs and wells), and discharge point(s) where the facility's storm water discharges to a municipal storm drain system or other points of discharge to waters of the State. The requirements of this paragraph may be included in the site map required under the following paragraph if appropriate.
- b. A site map showing the following:
  - 1) Storm water conveyance, drainage, and discharge structures;
  - 2) An outline of the storm water drainage areas for each storm water discharge point;
  - 3) Paved areas and buildings;
  - 4) Areas of actual or potential pollutant contact with storm water or release to storm water, including but not limited to outdoor storage and process areas; material loading, unloading, and access areas; and waste treatment, storage, and disposal areas;
  - 5) Location of existing storm water structural control measures (i.e., berms, coverings, etc.);
  - 6) Surface water locations, including springs and wetlands; and
  - 7) Vehicle service areas.
- c. A narrative description of the following:
  - 1) Wastewater treatment process activity areas;
  - 2) Materials, equipment, and vehicle management practices employed to minimize contact of significant materials of concern with storm water discharges;
  - 3) Material storage, loading, unloading, and access areas;
  - 4) Existing structural and non-structural control measures (if any) to reduce pollutants in storm water discharges; and
  - 5) Methods of on-site storage and disposal of significant materials.
- d. A list of pollutants that have a reasonable potential to be present in storm water discharges in significant quantities.

### 3. Storm Water Management Controls

The SWPP Plan shall describe the storm water management controls appropriate for the facility and a time schedule for fully implementing such controls. The appropriateness and priorities of controls in the SWPP Plan shall reflect identified potential sources of pollutants. The description of storm water management controls to be implemented shall include, as appropriate:

a. Storm water pollution prevention personnel

Identify specific individuals (and job titles) that are responsible for developing, implementing, and reviewing the SWPP Plan.

b. Good housekeeping

Good housekeeping requires the maintenance of clean, orderly facility areas that discharge storm water. Material handling areas shall be inspected and cleaned to reduce the potential for pollutants to enter the storm drain conveyance system.

c. Spill prevention and response

Identify areas where significant materials can spill into or otherwise enter storm water conveyance systems and their accompanying drainage points. Specific material handling procedures, storage requirements, and cleanup equipment and procedures shall be identified, as appropriate. The necessary equipment to implement a cleanup shall be available, and personnel shall be trained in proper response, containment, and cleanup of spills. Internal reporting procedures for spills of significant materials shall be established.

d. Source control

Source controls include, for example, elimination or reduction of the use of toxic pollutants, covering of pollutant source areas, sweeping of paved areas, containment of potential pollutants, labeling of all storm drain inlets with “No Dumping” signs, isolation or separation of industrial and non-industrial pollutant sources so that runoff from these areas does not mix, etc.

e. Storm water management practices

Storm water management practices are practices other than those that control the sources of pollutants. Such practices include treatment or conveyance structures, such as drop inlets, channels, retention and detention basins, treatment vaults, infiltration galleries, filters, oil/water separators, etc. Based on assessment of the potential of various sources to contribute pollutants to storm water discharges in significant quantities, additional storm water management practices to remove pollutants from storm water discharges shall be implemented and design criteria shall be described.

f. Sediment and erosion control

Measures to minimize erosion around the storm water drainage and discharge points, such as riprap, revegetation, slope stabilization, etc., shall be described.

g. Employee training

Employee training programs shall inform all personnel responsible for implementing the SWPP Plan. Training shall address spill response, good housekeeping, and material management practices. New employee and refresher training schedules shall be identified.

h. Inspections

All inspections shall be done by trained personnel. Material handling areas shall be inspected for evidence of, or the potential for, pollutants entering storm water discharges. A tracking or follow up procedure shall be used to ensure appropriate response has been taken in response to an inspection. Inspections and maintenance activities shall be documented and recorded. Inspection records shall be retained for five years.

i. Records

A tracking and follow-up procedure shall be described to ensure that adequate response and corrective actions have been taken in response to inspections.

**4. Annual Verification of SWPP Plan**

An annual facility inspection shall be conducted to verify that all elements of the SWPP Plan are accurate and up-to-date. The results of this review shall be reported in the Annual Report to the Regional Water Board described in Section V.C.f.

**K. Biosolids Management** – This section is an addition to Standard Provisions (Attachment D)

Biosolids must meet the following requirements prior to land application. The Discharger must either demonstrate compliance or, if it sends the biosolids to another party for further treatment or distribution, must give the recipient the information necessary to ensure compliance.

1. Exceptional quality biosolids meet the pollutant concentration limits in Table III of 40 CFR Part 503.13, Class A pathogen limits, and one of the vector attraction reduction requirements in 503.33(b)(1)-(b)(8). Such biosolids do not have to be tracked further for compliance with general requirements (503.12) and management practices (503.14).
2. Biosolids used for agricultural land, forest, or reclamation shall meet the pollutant limits in Table I (ceiling concentrations) and Table II or Table III (cumulative loadings or pollutant concentration limits) of 503.13. They shall also meet the general requirements (503.12) and management practices (503.14) (if not exceptional quality biosolids) for Class A or Class B pathogen levels with associated access restrictions (503.32) and one of the 10 vector attraction reduction requirements in 503.33(b)(1)-(b)(10).
3. Biosolids used for lawn or home gardens must meet exceptional quality biosolids limits.
4. Biosolids sold or given away in a bag or other container must meet the pollutant limits in either Table III or Table IV (pollutant concentration limits or annual pollutant loading rate limits) of 503.13. If Table IV is used, a label or information sheet must be attached to the biosolids packing that explains Table IV (see 503.14). The biosolids must also meet the Class A pathogen limits and one of the vector attraction reduction requirements in 503.33(b)(1)-(b)(8).



## II. STANDARD PROVISIONS – PERMIT ACTION – Not Supplemented

## III. STANDARD PROVISIONS – MONITORING

### A. Sampling and Analyses – This section is a supplement to III.A and III.B of Standard Provisions (Attachment D)

#### 1. Use of Certified Laboratories

Water and waste analyses shall be performed by a laboratory certified for these analyses in accordance with California Water Code Section 13176.

#### 2. Use of Appropriate Minimum Levels

Table C lists the suggested analytical methods for the 126 priority pollutants and other toxic pollutants that should be used, unless a particular method or minimum level (ML) is required in the MRP.

For priority pollutant monitoring, when there is more than one ML value for a given substance, the Discharger may select any one of the analytical methods cited in Table C for compliance determination, or any other method described in 40 CFR part 136 or approved by U.S. EPA (such as the 1600 series) if authorized by the Regional Water Board. However, the ML must be below the effluent limitation and water quality objective. If no ML value is below the effluent limitation and water quality objective, then the method must achieve an ML no greater than the lowest ML value indicated in Table C. All monitoring instruments and equipment shall be properly calibrated and maintained to ensure accuracy of measurements.

#### 3. Frequency of Monitoring

The minimum schedule of sampling analysis is specified in the MRP portion of the permit.

##### a. Timing of Sample Collection

- 1) The Discharger shall collect samples of influent on varying days selected at random and shall not include any plant recirculation or other sidestream wastes, unless otherwise stipulated by the MRP.
- 2) The Discharger shall collect samples of effluent on days coincident with influent sampling unless otherwise stipulated by the MRP or the Executive Officer. The Executive Officer may approve an alternative sampling plan if it is demonstrated to be representative of plant discharge flow and in compliance with all other permit requirements.
- 3) The Discharger shall collect grab samples of effluent during periods of day-time maximum peak effluent flows (or peak flows through secondary treatment units for facilities that recycle effluent flows).
- 4) Effluent sampling for conventional pollutants shall occur on at least one day of any multiple-day bioassay test the MRP requires. During the course of the test, on at least one day, the Discharger shall collect and retain samples of the discharge. In the event a bioassay test does

not comply with permit limits, the Discharger shall analyze these retained samples for pollutants that could be toxic to aquatic life and for which it has effluent limits.

- i. The Discharger shall perform bioassay tests on final effluent samples; when chlorine is used for disinfection, bioassay tests shall be performed on effluent after chlorination-dechlorination; and
- ii. The Discharger shall analyze for total ammonia nitrogen and calculate the amount of un-ionized ammonia whenever test results fail to meet the percent survival specified in the permit.

b. Conditions Triggering Accelerated Monitoring

- 1) If the results from two consecutive samples of a constituent monitored in a 30-day period exceed the monthly average limit for any parameter (or if the required sampling frequency is once per month and the monthly sample exceeds the monthly average limit), the Discharger shall, within 24 hours after the results are received, increase its sampling frequency to daily until the results from the additional sampling show that the parameter is in compliance with the monthly average limit.
- 2) If any maximum daily limit is exceeded, the Discharger shall increase its sampling frequency to daily within 24 hours after the results are received that indicate the exceedance of the maximum daily limit until two samples collected on consecutive days show compliance with the maximum daily limit.
- 3) If final or intermediate results of an acute bioassay test indicate a violation or threatened violation (e.g., the percentage of surviving test organisms of any single acute bioassay test is less than 70 percent), the Discharger shall initiate a new test as soon as practical, and the Discharger shall investigate the cause of the mortalities and report its findings in the next self monitoring report (SMR).
- 4) The Discharger shall calibrate chlorine residual analyzers against grab samples as frequently as necessary to maintain accurate control and reliable operation. If an effluent violation is detected, the Discharger shall collect grab samples at least every 30 minutes until compliance with the limit is achieved, unless the Discharger monitors chlorine residual continuously. In such cases, the Discharger shall continue to conduct continuous monitoring as required by its permit.
- 5) When a bypass occurs (except one subject to provision III.A.3.b.6 below), the Discharger shall monitor flows and collect samples on a daily basis for all constituents at affected discharge points that have effluent limits for the duration of the bypass (including acute toxicity using static renewals), except chronic toxicity, unless otherwise stipulated by the MRP.
- 6) Unless otherwise stipulated by the MRP, when a bypass approved pursuant to Attachment D, Standard Provisions, Sections I.G.2 or I.G.4, occurs, the Discharger shall monitor flows and, using appropriate procedures as specified in the MRP, collect and retain samples for affected discharge points on a daily basis for the duration of the bypass. The Discharger shall analyze for total suspended solids (TSS) using 24-hour composites (or more frequent increments) and for bacteria indicators with effluent limits using grab samples. If TSS exceeds 45 mg/L in any composite sample, the Discharger shall also analyze the retained samples for that discharge for all other constituents that have effluent limits, except oil and grease, mercury, dioxin-

TEQ, and acute and chronic toxicity. Additionally, at least once each year, the Discharger shall analyze the retained samples for one approved bypass discharge event for all other constituents that have effluent limits, except oil and grease, mercury, dioxin-TEQ, and acute and chronic toxicity. This monitoring shall be in addition to the minimum monitoring specified in the MRP.

c. Storm Water Monitoring

The requirements of this section only apply to facilities that are not covered by an NPDES permit for storm water discharges and where not all site storm drainage from process areas (i.e., areas of the treatment facility where chemicals or wastewater could come in contact with storm water) is directed to the headworks. For storm water not directed to the headworks during the wet season (October 1 to April 30), the Discharger shall:

- 1) Conduct visual observations of the storm water discharge locations during daylight hours at least once per month during a storm event that produces significant storm water discharge to observe the presence of floating and suspended materials, oil and grease, discoloration, turbidity, and odor, etc.
- 2) Measure (or estimate) the total volume of storm water discharge, collect grab samples of storm water discharge from at least two storm events that produce significant storm water discharge, and analyze the samples for oil and grease, pH, TSS, and specific conductance.

The grab samples shall be taken during the first 30 minutes of the discharge. If collection of the grab samples during the first 30 minutes is impracticable, grab samples may be taken during the first hour of the discharge, and the Discharger shall explain in the Annual Report why the grab sample(s) could not be taken in the first 30 minutes.

- 3) Testing for the presence of non-storm water discharges shall be conducted no less than twice during the dry season (May 1 to September 30) at all storm water discharge locations. Tests may include visual observations of flows, stains, sludges, odors, and other abnormal conditions; dye tests; TV line surveys; or analysis and validation of accurate piping schematics. Records shall be maintained describing the method used, date of testing, locations observed, and test results.
- 4) Samples shall be collected from all locations where storm water is discharged. Samples shall represent the quality and quantity of storm water discharged from the facility. If a facility discharges storm water at multiple locations, the Discharger may sample a reduced number of locations if it establishes and documents through the monitoring program that storm water discharges from different locations are substantially identical.
- 5) Records of all storm water monitoring information and copies of all reports required by the permit shall be retained for a period of at least three years from the date of sample, observation, or report.

d. Receiving Water Monitoring

The requirements of this section only apply when the MRP requires receiving water sampling.

- 1) Receiving water samples shall be collected on days coincident with effluent sampling for conventional pollutants.
- 2) Receiving water samples shall be collected at each station on each sampling day during the period within one hour following low slack water. Where sampling during lower slack water is impractical, sampling shall be performed during higher slack water. Samples shall be collected within the discharge plume and down current of the discharge point so as to be representative, unless otherwise stipulated in the MRP.
- 3) Samples shall be collected within one foot of the surface of the receiving water, unless otherwise stipulated in the MRP.

**B. Biosolids Monitoring** – This section supplements III.B of Standard Provisions (Attachment D)

When biosolids are sent to a landfill, sent to a surface disposal site, or applied to land as a soil amendment, they must be monitored as follows:

**1. Biosolids Monitoring Frequency**

Biosolids disposal must be monitored at the following frequency:

<u>Metric tons biosolids/365 days</u>	<u>Frequency</u>
0-290	Once per year
290-1500	Quarterly
1500-15,000	Six times per year
Over 15,000	Once per month

(Metric tons are on a dry weight basis)

**2. Biosolids Pollutants to Monitor**

Biosolids shall be monitored for the following constituents:

- Land Application: Arsenic, cadmium, copper, mercury, molybdenum, nickel, lead, selenium, and zinc
- Municipal Landfill: Paint filter test (pursuant to 40 CFR 258)
- Biosolids-only Landfill or Surface Disposal Site (if no liner and leachate system): arsenic, chromium, and nickel

**C. Standard Observations** – This section is an addition to III of Standard Provisions (AttachmentD)

**1. Receiving Water Observations**

The requirements of this section only apply when the MRP requires standard observations of the receiving water. Standard observations shall include the following:

- a. *Floating and suspended materials* (e.g., oil, grease, algae, and other macroscopic particulate matter): presence or absence, source, and size of affected area.
- b. *Discoloration and turbidity*: description of color, source, and size of affected area.
- c. *Odor*: presence or absence, characterization, source, distance of travel, and wind direction.
- d. *Beneficial water use*: presence of water-associated waterfowl or wildlife, fisherpeople, and other recreational activities in the vicinity of each sampling station.
- e. *Hydrographic condition*: time and height of corrected high and low tides (corrected to nearest National Oceanic and Atmospheric Administration location for the sampling date and time of sample collection).
- f. *Weather conditions*:
  - 1) Air temperature; and
  - 2) Total precipitation during the five days prior to observation.

## 2. Wastewater Effluent Observations

The requirements of this section only apply when the MRP requires wastewater effluent standard observations. Standard observations shall include the following:

- a. *Floating and suspended material of wastewater origin* (e.g., oil, grease, algae, and other macroscopic particulate matter): presence or absence.
- b. *Odor*: presence or absence, characterization, source, distance of travel, and wind direction.

## 3. Beach and Shoreline Observations

The requirements of this section only apply when the MRP requires beach and shoreline standard observations. Standard observations shall include the following:

- a. *Material of wastewater origin*: presence or absence, description of material, estimated size of affected area, and source.
- b. *Beneficial use*: estimate number of people participating in recreational water contact, non-water contact, or fishing activities.

## 4. Land Retention or Disposal Area Observations

The requirements of this section only apply to facilities with on-site surface impoundments or disposal areas that are in use. This section applies to both liquid and solid wastes, whether confined or unconfined. The Discharger shall conduct the following for each impoundment:

- a. Determine the amount of freeboard at the lowest point of dikes confining liquid wastes.
- b. Report evidence of leaching liquid from area of confinement and estimated size of affected area. Show affected area on a sketch and volume of flow (e.g., gallons per minute [gpm]).

- c. Regarding odor, describe presence or absence, characterization, source, distance of travel, and wind direction.
- d. Estimate number of waterfowl and other water-associated birds in the disposal area and vicinity.

#### 5. Periphery of Waste Treatment and/or Disposal Facilities Observations

The requirements of this section only apply when the MRP specifies periphery standard observations. Standard observations shall include the following:

- a. *Odor*: presence or absence, characterization, source, and distance of travel.
- b. *Weather conditions*: wind direction and estimated velocity.

### IV. STANDARD PROVISIONS – RECORDS

#### A. Records to be Maintained – This supplements IV.A of Standard Provisions (Attachment D)

The Discharger shall maintain records in a manner and at a location (e.g., wastewater treatment plant or Discharger offices) such that the records are accessible to Regional Water Board staff. The minimum period of retention specified in Section IV, Records, of the Federal Standard Provisions shall be extended during the course of any unresolved litigation regarding the subject discharge, or when requested by the Regional Water Board or Regional Administrator of U.S. EPA, Region IX.

A copy of the permit shall be maintained at the discharge facility and be available at all times to operating personnel.

#### B. Records of monitoring information shall include – This supplements IV.B of Standard Provision (Attachment D)

##### 1. Analytical Information

Records shall include analytical method detection limits, minimum levels, reporting levels, and related quantification parameters.

##### 2. Flow Monitoring Data

For all required flow monitoring (e.g., influent and effluent flows), the additional records shall include the following, unless otherwise stipulated by the MRP:

- a. Total volume for each day; and
- b. Maximum, minimum, and average daily flows for each calendar month.

### 3. Wastewater Treatment Process Solids

- a. For each treatment unit process that involves solids removal from the wastewater stream, records shall include the following:
  - 1) Total volume or mass of solids removed from each collection unit (e.g., grit, skimmings, undigested biosolids, or combination) for each calendar month or other time period as appropriate, but not to exceed annually; and
  - 2) Final disposition of such solids (e.g., landfill, other subsequent treatment unit).
- b. For final dewatered biosolids from the treatment plant as a whole, records shall include the following:
  - 1) Total volume or mass of dewatered biosolids for each calendar month;
  - 2) Solids content of the dewatered biosolids; and
  - 3) Final disposition of dewatered biosolids (disposal location and disposal method).

### 4. Disinfection Process

For the disinfection process, these additional records shall be maintained documenting process operation and performance:

- a. For bacteriological analyses:
  - 1) Wastewater flow rate at the time of sample collection; and
  - 2) Required statistical parameters for cumulative bacterial values (e.g., moving median or geometric mean for the number of samples or sampling period identified in this Order).
- b. For the chlorination process, when chlorine is used for disinfection, at least daily average values for the following:
  - 1) Chlorine residual of treated wastewater as it enters the contact basin (mg/L);
  - 2) Chlorine dosage (kg/day); and
  - 3) Dechlorination chemical dosage (kg/day).

### 5. Treatment Process Bypasses

A chronological log of all treatment process bypasses, including wet weather blending, shall include the following:

- a. Identification of the treatment process bypassed;
- b. Dates and times of bypass beginning and end;
- c. Total bypass duration;

- d. Estimated total bypass volume; and
- e. Description of, or reference to other reports describing, the bypass event, the cause, the corrective actions taken (except for wet weather blending that is in compliance with permit conditions), and any additional monitoring conducted.

#### **6. Treatment Facility Overflows**

This section applies to records for overflows at the treatment facility. This includes the headworks and all units and appurtenances downstream. The Discharger shall retain a chronological log of overflows at the treatment facility and records supporting the information provided in section V.E.2.

#### **C. Claims of Confidentiality – Not Supplemented**

### **V. STANDARD PROVISIONS – REPORTING**

#### **A. Duty to Provide Information – Not Supplemented**

#### **B. Signatory and Certification Requirements – Not Supplemented**

#### **C. Monitoring Reports – This section supplements V.C of Standard Provisions (Attachment D)**

##### **1. Self Monitoring Reports**

For each reporting period established in the MRP, the Discharger shall submit an SMR to the Regional Water Board in accordance with the requirements listed in this document and at the frequency the MRP specifies. The purpose of the SMR is to document treatment performance, effluent quality, and compliance with the waste discharge requirements of this Order.

##### **a. Transmittal letter**

Each SMR shall be submitted with a transmittal letter. This letter shall include the following:

- 1) Identification of all violations of effluent limits or other waste discharge requirements found during the reporting period;
- 2) Details regarding violations: parameters, magnitude, test results, frequency, and dates;
- 3) Causes of violations;
- 4) Discussion of corrective actions taken or planned to resolve violations and prevent recurrences, and dates or time schedule of action implementation (if previous reports have been submitted that address corrective actions, reference to the earlier reports is satisfactory);
- 5) Data invalidation (Data should not be submitted in an SMR if it does not meet quality assurance/quality control standards. However, if the Discharger wishes to invalidate any measurement after it was submitted in an SMR, a letter shall identify the measurement suspected to be invalid and state the Discharger's intent to submit, within 60 days, a formal request to invalidate the measurement. This request shall include the original measurement in question, the reason for invalidating the measurement, all relevant documentation that



supports invalidation [e.g., laboratory sheet, log entry, test results, etc.], and discussion of the corrective actions taken or planned [with a time schedule for completion] to prevent recurrence of the sampling or measurement problem.);

- 6) If the Discharger blends, the letter shall describe the duration of blending events and certify whether blended effluent was in compliance with the conditions for blending; and
- 7) Signature (The transmittal letter shall be signed according to Section V.B of this Order, Attachment D – Standard Provisions.).

b. Compliance evaluation summary

Each report shall include a compliance evaluation summary. This summary shall include each parameter for which the permit specifies effluent limits, the number of samples taken during the monitoring period, and the number of samples that exceed applicable effluent limits.

c. Results of analyses and observations

- 1) Tabulations of all required analyses and observations, including parameter, date, time, sample station, type of sample, test result, method detection limit, method minimum level, and method reporting level, if applicable, signed by the laboratory director or other responsible official.
- 2) When determining compliance with an average monthly effluent limitation and more than one sample result is available in a month, the Discharger shall compute the arithmetic mean unless the data set contains one or more reported determinations of detected but not quantified (DNQ) or nondetect (ND). In those cases, the Discharger shall compute the median in place of the arithmetic mean in accordance with the following procedure:
  - i. The data set shall be ranked from low to high, reported ND determinations lowest, DNQ determinations next, followed by quantified values (if any). The order of the individual ND or DNQ determinations is unimportant.
  - ii. The median value of the data set shall be determined. If the data set has an odd number of data points, then the median is the middle value. If the data set has an even number of data points, then the median is the average of the two values around the middle unless one or both of the points are ND or DNQ, in which case the median value shall be the lower of the two data points where DNQ is lower than a value and ND is lower than DNQ.

If a sample result, or the arithmetic mean or median of multiple sample results, is below the reporting limit, and there is evidence that the priority pollutant is present in the effluent above an effluent limitation and the Discharger conducts a Pollutant Minimization Program, the Discharger shall not be deemed out of compliance.

- 3) Dioxin-TEQ Reporting: The Discharger shall report for each dioxin and furan congener the analytical results of effluent monitoring, including the quantifiable limit (reporting level), the method detection limit, and the measured concentration. The Discharger shall report all measured values of individual congeners, including data qualifiers. When calculating dioxin-TEQ, the Discharger shall set congener concentrations below the minimum levels (ML) to zero. The Discharger shall calculate and report dioxin-TEQs using the following formula,

where the MLs, toxicity equivalency factors (TEFs), and bioaccumulation equivalency factors (BEFs) are as provided in Table A:

$$\text{Dioxin-TEQ} = \sum (C_x \times \text{TEF}_x \times \text{BEF}_x)$$

where:  $C_x$  = measured or estimated concentration of congener  $x$   
 $\text{TEF}_x$  = toxicity equivalency factor for congener  $x$   
 $\text{BEF}_x$  = bioaccumulation equivalency factor for congener  $x$

**Table A**  
 Minimum Levels, Toxicity Equivalency Factors,  
 and Bioaccumulation Equivalency Factors

Dioxin or Furan Congener	Minimum Level (pg/L)	1998 Toxicity Equivalency Factor (TEF)	Bioaccumulation Equivalency Factor (BEF)
2,3,7,8-TCDD	10	1.0	1.0
1,2,3,7,8-PeCDD	50	1.0	0.9
1,2,3,4,7,8-HxCDD	50	0.1	0.3
1,2,3,6,7,8-HxCDD	50	0.1	0.1
1,2,3,7,8,9-HxCDD	50	0.1	0.1
1,2,3,4,6,7,8-HpCDD	50	0.01	0.05
OCDD	100	0.0001	0.01
2,3,7,8-TCDF	10	0.1	0.8
1,2,3,7,8-PeCDF	50	0.05	0.2
2,3,4,7,8-PeCDF	50	0.5	1.6
1,2,3,4,7,8-HxCDF	50	0.1	0.08
1,2,3,6,7,8-HxCDF	50	0.1	0.2
1,2,3,7,8,9-HxCDF	50	0.1	0.6
2,3,4,6,7,8-HxCDF	50	0.1	0.7
1,2,3,4,6,7,8-HpCDF	50	0.01	0.01
1,2,3,4,7,8,9-HpCDF	50	0.01	0.4
OCDF	100	0.0001	0.02

d. Data reporting for results not yet available

The Discharger shall make all reasonable efforts to obtain analytical data for required parameter sampling in a timely manner. Certain analyses require additional time to complete analytical processes and report results. For cases where required monitoring parameters require additional time to complete analytical processes and reports, and results are not available in time to be included in the SMR for the subject monitoring period, the Discharger shall describe such circumstances in the SMR and include the data for these parameters and relevant discussions of any observed exceedances in the next SMR due after the results are available.

e. Flow data

The Discharger shall provide flow data tabulation pursuant to Section IV.B.2.

f. Annual self monitoring report requirements

By the date specified in the MRP, the Discharger shall submit an annual report to the Regional Water Board covering the previous calendar year. The report shall contain the following:

- 1) Annual compliance summary table of treatment plant performance, including documentation of any blending events;
- 2) Comprehensive discussion of treatment plant performance and compliance with the permit (This discussion shall include any corrective actions taken or planned, such as changes to facility equipment or operation practices that may be needed to achieve compliance, and any other actions taken or planned that are intended to improve performance and reliability of the Discharger's wastewater collection, treatment, or disposal practices.);
- 3) Both tabular and graphical summaries of the monitoring data for the previous year if parameters are monitored at a frequency of monthly or greater;
- 4) List of approved analyses, including the following:
  - (i) List of analyses for which the Discharger is certified;
  - (ii) List of analyses performed for the Discharger by a separate certified laboratory (copies of reports signed by the laboratory director of that laboratory shall not be submitted but be retained onsite); and
  - (iii) List of "waived" analyses, as approved;
- 5) Plan view drawing or map showing the Discharger's facility, flow routing, and sampling and observation station locations;
- 6) Results of annual facility inspection to verify that all elements of the SWPP Plan are accurate and up to date (only required if the Discharger does not route all storm water to the headworks of its wastewater treatment plant); and
- 7) Results of facility report reviews (The Discharger shall regularly review, revise, and update, as necessary, the O&M Manual, the Contingency Plan, the Spill Prevention Plan, and Wastewater Facilities Status Report so that these documents remain useful and relevant to current practices. At a minimum, reviews shall be conducted annually. The Discharger shall include, in each Annual Report, a description or summary of review and evaluation procedures, recommended or planned actions, and an estimated time schedule for implementing these actions. The Discharger shall complete changes to these documents to ensure they are up-to-date.).

g. Report submittal

The Discharger shall submit SMRs to:

California Regional Water Quality Control Board

San Francisco Bay Region  
1515 Clay Street, Suite 1400  
Oakland, CA 94612  
Attn: NPDES Wastewater Division

h. Reporting data in electronic format

The Discharger has the option to submit all monitoring results in an electronic reporting format approved by the Executive Officer. If the Discharger chooses to submit SMRs electronically, the following shall apply:

- 1) *Reporting Method*: The Discharger shall submit SMRs electronically via a process approved by the Executive Officer (see, for example, the letter dated December 17, 1999, "Official Implementation of Electronic Reporting System [ERS]" and the progress report letter dated December 17, 2000).
- 2) *Monthly or Quarterly Reporting Requirements*: For each reporting period (monthly or quarterly as specified in the MRP), the Discharger shall submit an electronic SMR to the Regional Water Board in accordance with the provisions of Section V.C.1.a-e, except for requirements under Section V.C.1.c(1) where ERS does not have fields for dischargers to input certain information (e.g., sample time). However, until U.S. EPA approves the electronic signature or other signature technologies, Dischargers that use ERS shall submit a hard copy of the original transmittal letter, an ERS printout of the data sheet, and a violation report (a receipt of the electronic transmittal shall be retained by the Discharger). This electronic SMR submittal suffices for the signed tabulations specified under Section V.C.1.c(1).
- 3) *Annual Reporting Requirements*: Dischargers who have submitted data using the ERS for at least one calendar year are exempt from submitting the portion of the annual report required under Section V.C.1.f(1) and (3).

**D. Compliance Schedules** – Not supplemented

**E. Twenty-Four Hour Reporting** – This section supplements V.E of Standard Provision (Attachment D)

**1. Spill of Oil or Other Hazardous Material Reports**

- a. Within 24 hours of becoming aware of a spill of oil or other hazardous material that is not contained onsite and completely cleaned up, the Discharger shall report by telephone to the Regional Water Board at (510) 622-2369.
- b. The Discharger shall also report such spills to the State Office of Emergency Services [telephone (800) 852-7550] only when the spills are in accordance with applicable reporting quantities for hazardous materials.
- c. The Discharger shall submit a written report to the Regional Water Board within five working days following telephone notification unless directed otherwise by Regional Water Board staff. A report submitted electronically is acceptable. The written report shall include the following:
  - 1) Date and time of spill, and duration if known;

- 2) Location of spill (street address or description of location);
- 3) Nature of material spilled;
- 4) Quantity of material involved;
- 5) Receiving water body affected, if any;
- 6) Cause of spill;
- 7) Estimated size of affected area;
- 8) Observed impacts to receiving waters (e.g., oil sheen, fish kill, water discoloration);
- 9) Corrective actions taken to contain, minimize, or clean up the spill;
- 10) Future corrective actions planned to be taken to prevent recurrence, and schedule of implementation; and
- 11) Persons or agencies notified.

## 2. Unauthorized Discharges from Municipal Wastewater Treatment Plants<sup>1</sup>

The following requirements apply to municipal wastewater treatment plants that experience an unauthorized discharge at their treatment facilities and are consistent with and supercede requirements imposed on the Discharger by the Executive Officer by letter of May 1, 2008, issued pursuant to California Water Code Section 13383.

### a. Two (2)-Hour Notification

For any unauthorized discharges that result in a discharge to a drainage channel or a surface water, the Discharger shall, as soon as possible, but not later than two (2) hours after becoming aware of the discharge, notify the State Office of Emergency Services (telephone 800-852-7550), the local health officers or directors of environmental health with jurisdiction over the affected water bodies, and the Regional Water Board. The notification to the Regional Water Board shall be via the Regional Water Board's online reporting system at [www.wbers.net](http://www.wbers.net), and shall include the following:

- 1) Incident description and cause;
- 2) Location of threatened or involved waterway(s) or storm drains;
- 3) Date and time the unauthorized discharge started;
- 4) Estimated quantity and duration of the unauthorized discharge (to the extent known), and the estimated amount recovered;

---

<sup>1</sup> California Code of Regulations, Title 23, Section 2250(b), defines an unauthorized discharge to be a discharge, not regulated by waste discharge requirements, of treated, partially treated, or untreated wastewater resulting from the intentional or unintentional diversion of wastewater from a collection, treatment or disposal system.

- 5) Level of treatment prior to discharge (e.g., raw wastewater, primary treated, undisinfected secondary treated, and so on); and
- 6) Identity of the person reporting the unauthorized discharge.

b. 24-hour Certification

Within 24 hours, the Discharger shall certify to the Regional Water Board, at [www.wbers.net](http://www.wbers.net), that the State Office of Emergency Services and the local health officers or directors of environmental health with jurisdiction over the affected water bodies have been notified of the unauthorized discharge.

c. 5-Day Written Report

Within five business days, the Discharger shall submit a written report, via the Regional Water Board's online reporting system at [www.wbers.net](http://www.wbers.net), that includes, in addition to the information required above, the following:

- 1) Methods used to delineate the geographical extent of the unauthorized discharge within receiving waters;
- 2) Efforts implemented to minimize public exposure to the unauthorized discharge;
- 3) Visual observations of the impacts (if any) noted in the receiving waters (e.g., fish kill, discoloration of water) and the extent of sampling if conducted;
- 4) Corrective measures taken to minimize the impact of the unauthorized discharge;
- 5) Measures to be taken to minimize the chances of a similar unauthorized discharge occurring in the future;
- 6) Summary of Spill Prevention Plan or O&M Manual modifications to be made, if necessary, to minimize the chances of future unauthorized discharges; and
- 7) Quantity and duration of the unauthorized discharge, and the amount recovered.

d. Communication Protocol

To clarify the multiple levels of notification, certification, and reporting, the current communication requirements for unauthorized discharges from municipal wastewater treatment plants are summarized in Table B that follows.

**Table B**  
 Summary of Communication Requirements for Unauthorized Discharges<sup>1</sup> from  
 Municipal Wastewater Treatment Plants

<b>Discharger is required to:</b>	<b>Agency Receiving Information</b>	<b>Time frame</b>	<b>Method for Contact</b>
1. Notify	California Emergency Management Agency (Cal EMA)	As soon as possible, but not later than <b>2 hours</b> after becoming aware of the unauthorized discharge.	Telephone – (800) 852-7550 (obtain a control number from Cal EMA)
	Local health department	As soon as possible, but not later than <b>2 hours</b> after becoming aware of the unauthorized discharge.	Depends on local health department
	Regional Water Board	As soon as possible, but not later than <b>2 hours</b> after becoming aware of the unauthorized discharge.	Electronic <sup>2</sup> <a href="http://www.wbers.net">www.wbers.net</a>
2. Certify	Regional Water Board	As soon as possible, but not later than <b>24 hours</b> after becoming aware of the unauthorized discharge.	Electronic <sup>3</sup> <a href="http://www.wbers.net">www.wbers.net</a>
3. Report	Regional Water Board	Within <b>5 business days</b> of becoming aware of the unauthorized discharge.	Electronic <sup>4</sup> <a href="http://www.wbers.net">www.wbers.net</a>

<sup>1</sup> California Code of Regulations, Title 23, Section 2250(b), defines an unauthorized discharge to be a discharge, not regulated by waste discharge requirements, of treated, partially treated, or untreated wastewater resulting from the intentional or unintentional diversion of wastewater from a collection, treatment or disposal system.

<sup>2</sup> In the event that the Discharger is unable to provide online notification within 2 hours of becoming aware of an unauthorized discharge, it shall phone the Regional Water Board’s spill hotline at (510) 622-2369 and convey the same information contained in the notification form. In addition, within 3 business days of becoming aware of the unauthorized discharge, the Discharger shall enter the notification information into the Regional Water Board’s online system in electronic format.

<sup>3</sup> In most instances, the 2-hour notification will also satisfy 24-hour certification requirements. This is because the notification form includes fields for documenting that OES and the local health department have been contacted. In other words, if the Discharger is able to complete all the fields in the notification form within 2 hours, certification requirements are also satisfied. In the event that the Discharger is unable to provide online certification within 24 hours of becoming aware of an unauthorized discharge, it shall phone the Regional Water Board’s spill hotline at (510) 622-2369 and convey the same information contained in the certification form. In addition, within 3 business days of becoming aware of the unauthorized discharge, the Discharger shall enter the certification information into the Regional Water Board’s online system in electronic format.

<sup>4</sup> If the Discharger cannot satisfy the 5-day reporting requirements via the Regional Water Board’s online reporting system, it shall submit a written report (preferably electronically in pdf) to the appropriate Regional Water Board case manager. In cases where the Discharger cannot satisfy the 5-day reporting requirements via the online reporting system, it must still complete the Regional Water Board’s online reporting requirements within 15 calendar days of becoming aware of the unauthorized discharge.

**F. Planned Changes** – Not supplemented

**G. Anticipated Noncompliance** – Not supplemented

**H. Other Noncompliance** – Not supplemented

**I. Other Information** – Not supplemented

**VI. STANDARD PROVISION – ENFORCEMENT** – Not Supplemented

**VII. ADDITIONAL PROVISIONS – NOTIFICATION LEVELS** – Not Supplemented

**VIII. DEFINITIONS** – This section is an addition to Standard Provisions (Attachment D)

More definitions can be found in Attachment A of this NPDES Permit.

1. Arithmetic Calculations

- a. Geometric mean is the antilog of the log mean or the back-transformed mean of the logarithmically transformed variables, which is equivalent to the multiplication of the antilogarithms. The geometric mean can be calculated with either of the following equations:

$$\text{Geometric Mean} = \text{Anti log} \left( \frac{1}{N} \sum_{i=1}^N \text{Log}(C_i) \right)$$

or

$$\text{Geometric Mean} = (C_1 * C_2 * \dots * C_N)^{1/N}$$

Where “N” is the number of data points for the period analyzed and “C” is the concentration for each of the “N” data points.

- b. Mass emission rate is obtained from the following calculation for any calendar day:

$$\text{Mass emission rate (lb/day)} = \frac{8.345}{N} \sum_{i=1}^N Q_i C_i$$

$$\text{Mass emission rate (kg/day)} = \frac{3.785}{N} \sum_{i=1}^N Q_i C_i$$

In which “N” is the number of samples analyzed in any calendar day and “Q<sub>i</sub>” and “C<sub>i</sub>” are the flow rate (MGD) and the constituent concentration (mg/L) associated with each of the “N” grab samples that may be taken in any calendar day. If a composite sample is taken, “C<sub>i</sub>” is the concentration measured in the composite sample and “Q<sub>i</sub>” is the average flow rate occurring during the period over which the samples are composited. The daily concentration of a constituent measured over any calendar day shall be determined from the flow-weighted average of the same constituent in the combined waste streams as follows:



$$C_d = \text{Average daily concentration} = \frac{1}{Q_t} \sum_{i=1}^N Q_i C_i$$

In which “N” is the number of component waste streams and “Q” and “C” are the flow rate (MGD) and the constituent concentration (mg/L) associated with each of the “N” waste streams. “Q<sub>t</sub>” is the total flow rate of the combined waste streams.

- c. Maximum allowable mass emission rate, whether for a 24-hour, weekly 7-day, monthly 30-day, or 6-month period, is a limitation expressed as a daily rate determined with the formulas in the paragraph above, using the effluent concentration limit specified in the permit for the period and the specified allowable flow.
- d. POTW removal efficiency is the ratio of pollutants removed by the treatment facilities to pollutants entering the treatment facilities (expressed as a percentage). The Discharger shall determine removal efficiencies using monthly averages (by calendar month unless otherwise specified) of pollutant concentration of influent and effluent samples collected at about the same time and using the following equation (or its equivalent):

$$\text{Removal Efficiency (\%)} = 100 \times [1 - (\text{Effluent Concentration} / \text{Influent Concentration})]$$

2. Biosolids means the solids, semi-liquid suspensions of solids, residues, screenings, grit, scum, and precipitates separated from or created in wastewater by the unit processes of a treatment system. It also includes, but is not limited to, all supernatant, filtrate, centrate, decantate, and thickener overflow and underflow in the solids handling parts of the wastewater treatment system.
3. Blending is the practice of recombining wastewater that has been biologically treated with wastewater that has bypassed around biological treatment units.
4. Bottom sediment sample is (1) a separate grab sample taken at each sampling station for the determination of selected physical-chemical parameters, or (2) four grab samples collected from different locations in the immediate vicinity of a sampling station while the boat is anchored and analyzed separately for macroinvertebrates.
5. Composite sample is a sample composed of individual grab samples collected manually or by an automatic sampling device on the basis of time or flow as specified in the MRP. For flow-based composites, the proportion of each grab sample included in the composite sample shall be within plus or minus five percent (+/-5%) of the representative flow rate of the waste stream being measured at the time of grab sample collection. Alternatively, equal volume grab samples may be individually analyzed with the flow-weighted average calculated by averaging flow-weighted ratios of each grab sample analytical result. Grab samples comprising time-based composite samples shall be collected at intervals not greater than those specified in the MRP. The quantity of each grab sample comprising a time-based composite sample shall be a set of flow proportional volumes as specified in the MRP. If a particular time-based or flow-based composite sampling protocol is not specified in the MRP, the Discharger shall determine and implement the most representative sampling protocol for the given parameter subject to Executive Officer approval.
6. Depth-integrated sample is defined as a water or waste sample collected by allowing a sampling device to fill during a vertical traverse in the waste or receiving water body being sampled. The Discharger shall collect depth-integrated samples in such a manner that the collected sample will be representative of the waste or water body at that sampling point.

7. Flow sample is an accurate measurement of the average daily flow volume using a properly calibrated and maintained flow measuring device.
8. Grab sample is an individual sample collected in a short period of time not exceeding 15 minutes. Grab samples represent only the condition that exists at the time the wastewater is collected.
9. Initial dilution is the process that results in the rapid and irreversible turbulent mixing of wastewater with receiving water around the point of discharge.
10. Overflow is the intentional or unintentional spilling or forcing out of untreated or partially treated wastes from a transport system (e.g., through manholes, at pump stations, and at collection points) upstream from the treatment plant headworks or from any part of a treatment plant facility.
11. Priority pollutants are those constituents referred to in 40 CFR Part 122 as promulgated in the Federal Register, Vol. 65, No. 97, Thursday, May 18, 2000, also known as the California Toxics Rule, the presence or discharge of which could reasonably be expected to interfere with maintaining designated uses.
12. Storm water means storm water runoff, snow melt runoff, and surface runoff and drainage. It excludes infiltration and runoff from agricultural land.
13. Toxic pollutant means any pollutant listed as toxic under federal Clean Water Act section 307(a)(1) or under 40 CFR 401.15.
14. Untreated waste is raw wastewater.
15. Waste, waste discharge, discharge of waste, and discharge are used interchangeably in the permit. The requirements of the permit apply to the entire volume of water, and the material therein, that is disposed of to surface and ground waters of the State of California.

**Table C**

List of Monitoring Parameters and Analytical Methods

CTR No.	Pollutant/Parameter	Analytical Method <sup>5</sup>	Minimum Levels <sup>6</sup> (µg/l)											
			GC	GCMS	LC	Color	FAA	GFAA	ICP	ICP MS	SPGFAA	HYD RIDE	CVAA	DCP
1.	Antimony	204.2					10	5	50	0.5	5	0.5		1000
2.	Arsenic	206.3				20		2	10	2	2	1		1000
3.	Beryllium						20	0.5	2	0.5	1			1000
4.	Cadmium	200 or 213					10	0.5	10	0.25	0.5			1000
5a.	Chromium (III)	SM 3500												
5b.	Chromium (VI)	SM 3500				10	5							1000
	Chromium (total) <sup>7</sup>	SM 3500					50	2	10	0.5	1			1000
6.	Copper	200.9					25	5	10	0.5	2			1000
7.	Lead	200.9					20	5	5	0.5	2			10,000
8.	Mercury	1631 (note) <sup>8</sup>												
9.	Nickel	249.2					50	5	20	1	5			1000
10.	Selenium	200.8 or SM 3114B or C						5	10	2	5	1		1000
11.	Silver	272.2					10	1	10	0.25	2			1000
12.	Thallium	279.2					10	2	10	1	5			1000
13.	Zinc	200 or 289					20		20	1	10			
14.	Cyanide	SM 4500 CN <sup>-</sup> C or I				5								
15.	Asbestos (only required for dischargers to MUN waters) <sup>9</sup>	0100.2 <sup>10</sup>												
16.	2,3,7,8-TCDD and 17 congeners (Dioxin)	1613												
17.	Acrolein	603	2.0	5										
18.	Acrylonitrile	603	2.0	2										
19.	Benzene	602	0.5	2										
33.	Ethylbenzene	602	0.5	2										
39.	Toluene	602	0.5	2										
20.	Bromoform	601	0.5	2										
21.	Carbon Tetrachloride	601	0.5	2										
22.	Chlorobenzene	601	0.5	2										
23.	Chlorodibromomethane	601	0.5	2										
24.	Chloroethane	601	0.5	2										
25.	2-Chloroethylvinyl Ether	601	1	1										

<sup>5</sup> The suggested method is the U.S. EPA Method unless otherwise specified (SM = Standard Methods). The Discharger may use another U.S. EPA-approved or recognized method if that method has a level of quantification below the applicable water quality objective. Where no method is suggested, the Discharger has the discretion to use any standard method.

<sup>6</sup> Minimum levels are from the *State Implementation Policy*. They are the concentration of the lowest calibration standard for that technique based on a survey of contract laboratories. Laboratory techniques are defined as follows: GC = Gas Chromatography; GCMS = Gas Chromatography/Mass Spectrometry; LC = High Pressure Liquid Chromatography; Color = Colorimetric; FAA = Flame Atomic Absorption; GFAA = Graphite Furnace Atomic Absorption; ICP = Inductively Coupled Plasma; ICPMS = Inductively Coupled Plasma/Mass Spectrometry; SPGFAA = Stabilized Platform Graphite Furnace Atomic Absorption (i.e., U.S. EPA 200.9); Hydride = Gaseous Hydride Atomic Absorption; CVAA = Cold Vapor Atomic Absorption; DCP = Direct Current Plasma.

<sup>7</sup> Analysis for total chromium may be substituted for analysis of chromium (III) and chromium (VI) if the concentration measured is below the lowest hexavalent chromium criterion (11 µg/l).

<sup>8</sup> The Discharger shall use ultra-clean sampling (U.S. EPA Method 1669) and ultra-clean analytical methods (U.S. EPA Method 1631) for mercury monitoring. The minimum level for mercury is 2 ng/l (or 0.002 µg/l).

<sup>9</sup> MUN = Municipal and Domestic Supply. This designation, if applicable, is in the Findings of the permit.

<sup>10</sup> Determination of Asbestos Structures over 10 [micrometers] in Length in Drinking Water Using MCE Filters, U.S. EPA 600/R-94-134, June 1994.

CTR No.	Pollutant/Parameter	Analytical Method <sup>5</sup>	Minimum Levels <sup>6</sup> (µg/l)											
			GC	GCMS	LC	Color	FAA	GFAA	ICP	ICP MS	SPGFAA	HYD RIDE	CVAA	DCP
26.	Chloroform	601	0.5	2										
75.	1,2-Dichlorobenzene	601	0.5	2										
76.	1,3-Dichlorobenzene	601	0.5	2										
77.	1,4-Dichlorobenzene	601	0.5	2										
27.	Dichlorobromomethane	601	0.5	2										
28.	1,1-Dichloroethane	601	0.5	1										
29.	1,2-Dichloroethane	601	0.5	2										
30.	1,1-Dichloroethylene or 1,1-Dichloroethene	601	0.5	2										
31.	1,2-Dichloropropane	601	0.5	1										
32.	1,3-Dichloropropylene or 1,3-Dichloropropene	601	0.5	2										
34.	Methyl Bromide or Bromomethane	601	1.0	2										
35.	Methyl Chloride or Chloromethane	601	0.5	2										
36.	Methylene Chloride or Dichloromethane	601	0.5	2										
37.	1,1,2,2-Tetrachloroethane	601	0.5	1										
38.	Tetrachloroethylene	601	0.5	2										
40.	1,2-Trans-Dichloroethylene	601	0.5	1										
41.	1,1,1-Trichloroethane	601	0.5	2										
42.	1,1,2-Trichloroethane	601	0.5	2										
43.	Trichloroethene	601	0.5	2										
44.	Vinyl Chloride	601	0.5	2										
45.	2-Chlorophenol	604	2	5										
46.	2,4-Dichlorophenol	604	1	5										
47.	2,4-Dimethylphenol	604	1	2										
48.	2-Methyl-4,6-Dinitrophenol or Dinitro-2-methylphenol	604	10	5										
49.	2,4-Dinitrophenol	604	5	5										
50.	2-Nitrophenol	604		10										
51.	4-Nitrophenol	604	5	10										
52.	3-Methyl-4-Chlorophenol	604	5	1										
53.	Pentachlorophenol	604	1	5										
54.	Phenol	604	1	1		50								
55.	2,4,6-Trichlorophenol	604	10	10										
56.	Acenaphthene	610 HPLC	1	1	0.5									
57.	Acenaphthylene	610 HPLC		10	0.2									
58.	Anthracene	610 HPLC		10	2									
60.	Benzo(a)Anthracene or 1,2 Benzanthracene	610 HPLC	10	5										
61.	Benzo(a)Pyrene	610 HPLC		10	2									
62.	Benzo(b)Fluoranthene or 3,4 Benzo(b)fluoranthene	610 HPLC		10	10									
63.	Benzo(ghi)Perylene	610 HPLC		5	0.1									
64.	Benzo(k)Fluoranthene	610 HPLC		10	2									
74.	Dibenzo(a,h)Anthracene	610 HPLC		10	0.1									
86.	Fluoranthene	610 HPLC	10	1	0.05									
87.	Fluorene	610 HPLC		10	0.1									
92.	Indeno(1,2,3-cd) Pyrene	610 HPLC		10	0.05									
100.	Pyrene	610 HPLC		10	0.05									
68.	Bis(2-Ethylhexyl)Phthalate	606 or 625	10	5										

CTR No.	Pollutant/Parameter	Analytical Method <sup>5</sup>	Minimum Levels <sup>6</sup> (µg/l)											
			GC	GCMS	LC	Color	FAA	GFAA	ICP	ICP MS	SPGFAA	HYD RIDE	CVAA	DCP
70.	Butylbenzyl Phthalate	606 or 625	10	10										
79.	Diethyl Phthalate	606 or 625	10	2										
80.	Dimethyl Phthalate	606 or 625	10	2										
81.	Di-n-Butyl Phthalate	606 or 625		10										
84.	Di-n-Octyl Phthalate	606 or 625		10										
59.	Benzidine	625		5										
65.	Bis(2-Chloroethoxy)Methane	625		5										
66.	Bis(2-Chloroethyl)Ether	625	10	1										
67.	Bis(2-Chloroisopropyl)Ether	625	10	2										
69.	4-Bromophenyl Phenyl Ether	625	10	5										
71.	2-Chloronaphthalene	625		10										
72.	4-Chlorophenyl Phenyl Ether	625		5										
73.	Chrysene	625		10	5									
78.	3,3'-Dichlorobenzidine	625		5										
82.	2,4-Dinitrotoluene	625	10	5										
83.	2,6-Dinitrotoluene	625		5										
85.	1,2-Diphenylhydrazine (note) <sup>11</sup>	625		1										
88.	Hexachlorobenzene	625	5	1										
89.	Hexachlorobutadiene	625	5	1										
90.	Hexachlorocyclopentadiene	625	5	5										
91.	Hexachloroethane	625	5	1										
93.	Isophorone	625	10	1										
94.	Naphthalene	625	10	1	0.2									
95.	Nitrobenzene	625	10	1										
96.	N-Nitrosodimethylamine	625	10	5										
97.	N-Nitrosodi-n-Propylamine	625	10	5										
98.	N-Nitrosodiphenylamine	625	10	1										
99.	Phenanthrene	625		5	0.05									
101.	1,2,4-Trichlorobenzene	625	1	5										
102.	Aldrin	608	0.005											
103.	α-BHC	608	0.01											
104.	β-BHC	608	0.005											
105.	γ-BHC (Lindane)	608	0.02											
106.	δ-BHC	608	0.005											
107.	Chlordane	608	0.1											
108.	4,4'-DDT	608	0.01											
109.	4,4'-DDE	608	0.05											
110.	4,4'-DDD	608	0.05											
111.	Dieldrin	608	0.01											
112.	Endosulfan (alpha)	608	0.02											
113.	Endosulfan (beta)	608	0.01											
114.	Endosulfan Sulfate	608	0.05											
115.	Endrin	608	0.01											
116.	Endrin Aldehyde	608	0.01											
117.	Heptachlor	608	0.01											
118.	Heptachlor Epoxide	608	0.01											

<sup>11</sup> Measurement for 1,2-Diphenylhydrazine may use azobenzene as a screen: if azobenzene is measured at >1 ug/l, then the Discharger shall analyze for 1,2-Diphenylhydrazine.

CTR No.	Pollutant/Parameter	Analytical Method <sup>5</sup>	Minimum Levels <sup>6</sup> (µg/l)											
			GC	GCMS	LC	Color	FAA	GFAA	ICP	ICP MS	SPGFAA	HYD RIDE	CVAA	DCP
119-125	PCBs: Aroclors 1016, 1221, 1232, 1242, 1248, 1254, 1260	608	0.5											
126.	Toxaphene	608	0.5											