

**San Francisco Bay Regional Water Quality Control Board**

**TENTATIVE ORDER No. R2-2018-00XX**  
**NPDES No. CA0037788**

The following discharger is subject to waste discharge requirements (WDRs) set forth in this Order.

**Table 1. Discharger Information**

<b>Discharger</b>	City of Burlingame and North Bayside System Unit (NBSU)
<b>Facility Name</b>	City of Burlingame Wastewater Treatment Facility and wastewater collection system
<b>Facility Address</b>	1103 Airport Boulevard Burlingame, CA 94010 San Mateo County
<b>CIWQS Place Number</b>	210839

**Table 2. Discharge Locations**

<b>Discharge Point</b>	<b>Effluent Description</b>	<b>Discharge Point Latitude</b>	<b>Discharge Point Longitude</b>	<b>Receiving Water</b>
002	Secondary Treated Municipal Wastewater	37.665278°	-122.361389°	Lower San Francisco Bay

**Table 3. Administrative Information**

This Order was adopted on:	<DATE>
This Order shall become effective on:	August 1, 2018
This Order shall expire on:	July 31, 2023
CIWQS Regulatory Measure Number	##
The Discharger shall file a Report of Waste Discharge for updated WDRs in accordance with California Code of Regulations, title 23, and as an application for reissuance of a National Pollutant Discharge Elimination System (NPDES) permit no later than:	November 1, 2022
The U.S. Environmental Protection Agency (U.S. EPA) and the California Regional Water Quality Control Board, San Francisco Bay Region, have classified this discharge as follows:	Major

I, Bruce H. Wolfe, Executive Officer, do hereby certify that this Order with all attachments is a full, true, and correct copy of the Order adopted by the California Regional Water Quality Control Board, San Francisco Bay Region, on the date indicated above.

\_\_\_\_\_  
Bruce H. Wolfe, Executive Officer

## Contents

I.	Facility Information .....	3
II.	Findings.....	3
III.	Discharge Prohibitions.....	3
IV.	Effluent Limitations and Discharge Specifications .....	4
V.	Receiving Water Limitations .....	6
VI.	Provisions.....	7
	A. Standard Provisions .....	7
	B. Monitoring and Reporting .....	7
	C. Special Provisions .....	7
	1. Reopener Provisions.....	7
	2. Effluent Characterization Study and Report .....	8
	3. Pollutant Minimization Program .....	9
	4. Special Provisions for Publicly-Owned Treatment Works (POTWs).....	11
	5. Other Special Provisions .....	12

## Tables

Table 1.	Discharger Information.....	1
Table 2.	Discharge Locations .....	1
Table 3.	Administrative Information .....	1
Table 4.	Effluent Limitations.....	4
Table 5.	Specific Tasks to Reduce Wet Weather Bypasses.....	12
Table 6.	Copper Action Plan.....	13
Table 7.	Cyanide Action Plan .....	14

## Attachments

Attachment A	– Definitions.....	A-1
Attachment B	– Facility Maps .....	B-1
Attachment C	– Process Flow Diagram .....	C-1
Attachment D	– Federal Standard Provisions .....	D-1
Attachment E	– Monitoring and Reporting Program (MRP).....	E-1
Attachment F	– Fact Sheet.....	F-1
Attachment G	– Regional Standard Provisions and Monitoring and Reporting Requirements .....	G-1
Attachment H	– Pretreatment Requirements .....	H-1

## I. FACILITY INFORMATION

Information describing the City of Burlingame Wastewater Treatment Facility and wastewater collection system (collectively, Facility) is summarized in Table 1 and Fact Sheet (Attachment F) sections I and II.

## II. FINDINGS

The California Regional Water Quality Control Board, San Francisco Bay Region (Regional Water Board), finds:

- A. Legal Authorities.** This Order serves as WDRs pursuant to California Water Code article 4, chapter 4, division 7 (commencing with § 13260). This Order is also issued pursuant to federal Clean Water Act (CWA) section 402 and implementing regulations adopted by U.S. EPA and Water Code chapter 5.5, division 7 (commencing with § 13370). It shall serve as a National Pollutant Discharge Elimination System (NPDES) permit authorizing the Discharger to discharge into waters of the United States as listed in Table 2 subject to the WDRs in this Order.
- B. Background and Rationale for Requirements.** The Regional Water Board developed the requirements in this Order based on information the Discharger submitted as part of its application, information obtained through monitoring and reporting programs, and other available information. The Fact Sheet (Attachment F) contains background information and rationale for the requirements in this Order and is hereby incorporated into and constitutes findings for this Order. Attachments A through E, G, and H are also incorporated into this Order.
- C. Provisions and Requirements Implementing State Law.** Provision VI.C.5.d (Anaerobically-Digestible Material) of this Order implements State law only. It is not required or authorized under the federal CWA; consequently, a violation of this provision is subject to the enforcement remedies available under the Water Code.
- D. Notification of Interested Parties.** The Regional Water Board notified the Discharger and interested agencies and persons of its intent to prescribe these WDRs and provided an opportunity to submit written comments and recommendations. The Fact Sheet provides details regarding the notification.
- E. Consideration of Public Comment.** The Regional Water Board, in a public meeting, heard and considered all comments pertaining to the discharge. The Fact Sheet provides details regarding the public hearing

**THEREFORE, IT IS HEREBY ORDERED** that Order No. R2-2013-0015 (previous order) is rescinded upon the effective date of this Order, except for enforcement purposes, and, in order to meet the provisions of Water Code division 7 (commencing with § 13000) and regulations adopted thereunder and the provisions of the CWA and regulations and guidelines adopted thereunder, the Discharger shall comply with the requirements in this Order. This action in no way prevents the Regional Water Board from taking enforcement action for violations of the previous order.

## III. DISCHARGE PROHIBITIONS

- A.** Discharge of treated wastewater at a location or in a manner different than that described in this Order is prohibited.

- B. Discharge at Discharge Point No. 002 is prohibited when treated wastewater does not receive an initial dilution of at least 74:1, as modeled. Compliance shall be achieved by proper operation and maintenance of the discharge outfall to ensure that it (or its replacement, in whole or part) is in good working order and is consistent with, or can achieve better mixing than that described in Fact Sheet section IV.C.4.b. The Discharger shall address measures taken to ensure this in its application for permit reissuance.
- C. Bypass of untreated or partially-treated wastewater to waters of the United States is prohibited, except as provided for in Attachment D section I.G of this Order.

Blending biologically treated wastewater with wastewater diverted around biological treatment units is approved under the bypass conditions stated in 40 CFR section 122.41(m)(4) when (1) the Discharger’s peak wet weather influent flow exceeds the capacity of the biological treatment units of 13.5 MGD, (2) the Discharger complies with the effluent and receiving water limitations contained in this Order, and (3) the Discharger complies with Provision VI.C.5.a of this Order. Furthermore, the Discharger shall operate the Facility as designed and in accordance with the Operation and Maintenance Manual for the Facility. This means it shall optimize storage and use of equalization units and shall fully use the biological treatment units. The Discharger shall report incidents of wet weather bypasses in routine monitoring reports and shall monitor blended discharges as specified in the Monitoring and Reporting Program (MRP) (Attachment E).

- D. Average dry weather influent flow in excess of 5.5 MGD is prohibited. Average dry weather influent flow shall be determined from three consecutive dry weather months each year, with compliance measured at Monitoring Location INF-001 as described in the MRP.
- E. Any sanitary sewer overflow that results in a discharge of untreated or partially-treated wastewater to waters of the United States is prohibited.

**IV. EFFLUENT LIMITATIONS AND DISCHARGE SPECIFICATIONS**

- A. **Effluent Limitations.** The Discharger shall comply with the following effluent limitations at Discharge Point No. 002, with compliance measured at Monitoring Location EFF-001 or EFF-001B, except total residual chlorine shall be measured at Monitoring Location EFF-002 and total cyanide shall be measured at Monitoring Location EFF-001 or EFF-001B, or Monitoring Location EFF-002, as described in the MRP.

**Table 4. Effluent Limitations**

Parameter	Units	Effluent Limitations				
		Average Monthly	Average Weekly	Maximum Daily	Instantaneous Minimum	Instantaneous Maximum
Biochemical Oxygen Demand, 5-day @ 20°C (BOD <sub>5</sub> )	mg/L	30	45	---	---	---
Total Suspended Solids (TSS)	mg/L	30	45	---	---	---
Oil and Grease	mg/L	10	---	20	---	---
pH <sup>[1]</sup>	s.u.	---	---	---	6.0	9.0
Chlorine, Total Residual	mg/L	---	---	---	---	0.0
Ammonia, Total	mg/L as N	66	---	130	---	---
Copper, Total Recoverable	µg/L	51	---	81	---	---

Parameter	Units	Effluent Limitations				
		Average Monthly	Average Weekly	Maximum Daily	Instantaneous Minimum	Instantaneous Maximum
Cyanide, Total	µg/L	17	---	42	---	---
Dioxin-TEQ	µg/L	1.4 x 10 <sup>-8</sup>	---	2.8 x 10 <sup>-8</sup>	---	---

Abbreviations:

mg/L = milligrams per liter  
 mg/L as N = milligrams per liter as nitrogen  
 µg/L = micrograms per liter  
 s.u. = standard units

Footnote:

<sup>[1]</sup> If the Discharger monitors pH continuously, pursuant to 40 C.F.R. section 401.17 the Discharger shall be in compliance with this pH limitation provided that both of the following conditions are satisfied: (i) the total time during which the pH is outside the required range shall not exceed 7 hours and 26 minutes in any calendar month; and (ii) no individual excursion from the required pH range shall exceed 60 minutes.

**B. Percent Removal.** The average monthly percent removal of BOD<sub>5</sub> and TSS at Discharge Point No. 002 shall not be less than 85 percent (i.e., in each calendar month, the arithmetic mean of BOD<sub>5</sub> and TSS, by concentration, of effluent samples collected at Monitoring Location EFF-001 or EFF-001B as described in the MRP, shall not exceed 15 percent of the arithmetic mean of BOD<sub>5</sub> and TSS, by concentration, of influent samples collected at Monitoring Location INF-001 as described in the MRP, at approximately the same times during the same periods). For a calendar month in which the Discharger discharges blended effluent at Discharge Point No. 002, the BOD<sub>5</sub> and TSS monthly arithmetic mean and percent removal shall include the results of blended effluent samples collected at Monitoring Location EFF-001B flow-weighted with effluent samples collected at Monitoring Location EFF-001.

**C. Fecal Coliform Bacteria.** The discharge at Discharge Point No. 002 shall meet the following fecal coliform bacteria effluent limitations, with compliance measured at Monitoring Locations EFF-001 and EFF-001B, as described in the MRP:

1. The geometric mean of all fecal coliform bacteria samples in a calendar month shall not exceed 200 MPN/100 mL; and
2. The 11-sample 90<sup>th</sup> percentile of all fecal coliform bacteria samples shall not exceed 400 MPN/100 mL.

**D. Enterococcus Bacteria.** The monthly geometric mean enterococcus bacteria concentration at Discharge Point No. 002 shall not exceed 35 MPN/100 mL, with compliance measured at Monitoring Locations EFF-001 and EFF-001B as described in the MRP.

**E. Whole Effluent Acute Toxicity.** The discharge at Discharge Point No. 002 shall meet the following acute toxicity effluent limitations, with compliance measured at Monitoring Locations EFF-001 and EFF-001B, as described in the MRP:

1. Eleven-sample median of not less than 90 percent survival; and
2. Eleven-sample 90<sup>th</sup> percentile of not less than 70 percent survival.

These acute toxicity limitations are defined as follows:

- **11-sample median.** A bioassay test showing survival of less than 90 percent represents a violation of this effluent limit if five or more of the past ten or fewer bioassay tests show less than 90 percent survival.
- **11-sample 90<sup>th</sup> percentile.** A bioassay test showing survival of less than 70 percent represents a violation of this effluent limit if one or more of the past ten or fewer bioassay tests show less than 70 percent survival.

If the Discharger can demonstrate that toxicity exceeding the levels cited above is caused solely by ammonia and that the ammonia in the discharge complies with the ammonia effluent limits in Table 4 of this Order, then such toxicity shall not constitute a violation of the acute toxicity effluent limitations.

## V. RECEIVING WATER LIMITATIONS

- A. The discharge shall not cause the following conditions to exist in receiving waters at any place:
1. Floating material, including solids, liquids, foams, and scum, in concentrations that cause nuisance or adversely affect beneficial uses;
  2. Alteration of suspended sediment in such a manner as to cause nuisance or adversely affect beneficial uses, or detrimental increase in the concentrations of toxic pollutants in sediments or aquatic life;
  3. Suspended material in concentrations that cause nuisance or adversely affect beneficial uses;
  4. Bottom deposits or aquatic growths to the extent that such deposits or growths cause nuisance or adversely affect beneficial uses;
  5. Alteration of temperature beyond present natural background levels unless it can be demonstrated to the satisfaction of the Regional Water Board that such alteration in temperature does not adversely affect beneficial uses;
  6. Changes in turbidity that cause nuisance or adversely affect beneficial uses, or increases from normal background light penetration or turbidity greater than 10 percent in areas where natural turbidity is greater than 50 nephelometric turbidity units;
  7. Coloration that causes nuisance or adversely affects beneficial uses;
  8. Visible, floating, suspended, or deposited oil or other products of petroleum origin; or
  9. Toxic or other deleterious substances in concentrations or quantities that cause deleterious effects on wildlife, waterfowl, or other aquatic biota, or render any of these unfit for human consumption, either at levels created in the receiving waters or as a result of biological concentration.
- B. The discharge shall not cause the following limits to be exceeded in receiving waters at any place within one foot of the water surface:
1. Dissolved Oxygen            5.0 mg/L, minimum

The median dissolved oxygen concentration for any three consecutive months shall not be less than 80 percent of the dissolved oxygen content at saturation. When natural factors cause concentrations less than that specified above, the discharge shall not cause further reduction in ambient dissolved oxygen concentrations.

2. Dissolved Sulfide                      Natural background levels
3. pH    The pH shall not be depressed below 6.5 or raised above 8.5. The discharge shall not cause changes greater than 0.5 pH units in normal ambient pH levels.
4. Nutrients                                      Waters shall not contain biostimulatory substances in concentrations that promote aquatic growths to the extent that such growths cause nuisance or adversely affect beneficial uses.

C. The discharge shall not cause a violation of any water quality standard for receiving waters adopted by the Regional Water Board or State Water Resources Control Board (State Water Board) as required by the CWA and regulations adopted thereunder. If more stringent water quality standards are promulgated or approved pursuant to CWA section 303, or amendments thereto, the Regional Water Board may revise or modify this Order in accordance with the more stringent standards.

## VI. PROVISIONS

### A. Standard Provisions

1. The Discharger shall comply with all “Standard Provisions” in Attachment D.
2. The Discharger shall comply with all applicable provisions of the “Regional Standard Provisions, and Monitoring and Reporting Requirements for NPDES Wastewater Discharge Permits” (Attachment G).

### B. Monitoring and Reporting

The Discharger shall comply with the MRP (Attachment E) and future revisions thereto, and applicable sampling and reporting requirements in Attachments D and G.

### C. Special Provisions

#### 1. Reopener Provisions

The Regional Water Board may modify or reopen this Order prior to its expiration date in any of the following circumstances as allowed by law:

- a. If present or future investigations demonstrate that the discharges governed by this Order have or will have, or will cease to have, a reasonable potential to cause or contribute to adverse impacts on water quality or beneficial uses of the receiving waters.

- b. If new or revised water quality objectives or total maximum daily loads (TMDLs) come into effect for San Francisco Bay or contiguous water bodies (whether statewide, regional, or site-specific). In such cases, effluent limitations in this Order may be modified as necessary to reflect the updated water quality objectives and wasteload allocations in the TMDLs. Adoption of the effluent limitations in this Order is not intended to restrict in any way future modifications based on legally-adopted water quality objectives or TMDLs or as otherwise permitted under federal regulations governing NPDES permit modifications.
- c. If translator, dilution, or other water quality studies provide a basis for determining that a permit condition should be modified.
- d. If State Water Board precedential decisions, new policies, new laws, or new regulations are adopted.
- e. If an administrative or judicial decision on a separate NPDES permit or WDRs addresses requirements similar to this discharge.
- f. If the Discharger requests adjustments in effluent limits due to the implementation of stormwater diversion pursuant to the Municipal Regional Stormwater Permit (Permit No. CAS612008) for redirecting dry weather and first flush discharges from the storm drain system to the sanitary sewer system as a stormwater pollutant control strategy.
- g. Or as otherwise authorized by law.

The Discharger may request a permit modification based on any of the circumstances above. With any such request, the Discharger shall include antidegradation and anti-backsliding analyses.

## 2. Effluent Characterization Study and Report

- a. **Study Elements.** The Discharger shall continue to characterize and evaluate the discharge from the following discharge point to verify that the “no” or “unknown” reasonable potential analysis conclusions of this Order remain valid and to inform the next permit reissuance. The Discharger shall collect representative samples at the monitoring station set forth below, as defined in the MRP, at no less than the frequency specified below:

<u>Discharge Point</u>	<u>Monitoring Location</u>	<u>Minimum Frequency</u>
002	EFF-001	1/Year

The samples shall be analyzed for the priority pollutants listed in Attachment G, Table B, except for those priority pollutants with effluent limitations where the MRP already requires more frequent monitoring, and except for those pollutants for which there are no water quality criteria (see Fact Sheet Table F-7). Compliance with this requirement shall be achieved in accordance with the specifications of Attachment G sections III.A.1 and III.A.2.

The Discharger shall evaluate on an annual basis if concentrations of any of these pollutants significantly increase over past performance. The Discharger shall investigate



the cause of any such increase. The investigation may include, but need not be limited to, an increase in monitoring frequency, monitoring of internal process streams, and monitoring of influent sources. The Discharger shall establish remedial measures addressing any increase resulting in reasonable potential to cause or contribute to an exceedance of applicable water quality objectives. This requirement may be satisfied through identification of the constituent as a “pollutant of concern” in the Discharger’s Pollutant Minimization Program, described in Provision VI.C.3.

#### **b. Reporting Requirements**

- i. Routine Reporting.** The Discharger shall report the following in the transmittal letter for the self-monitoring report associated with the month in which the samples were collected:
  - (a)** Indication that a sample for this characterization study was collected; and
  - (b)** Identity of pollutants detected at or above applicable water quality criteria (see Fact Sheet Table F-7 for the criteria), and the detected concentrations of those pollutants.
- ii. Annual Reporting.** The Discharger shall summarize the annual data evaluation and source investigation in the annual self-monitoring report.
- iii. Final Report.** The Discharger shall submit a final report that presents all these data with the application for permit reissuance. The Discharger need not resubmit data and information already submitted electronically into CIWQS; however, it shall reference the monthly monitoring reports where it provided such information.

### **3. Pollutant Minimization Program**

- a.** The Discharger shall continue to improve its existing Pollutant Minimization Program to promote minimization of pollutant loadings to the treatment plant and therefore to the receiving waters.
- b.** The Discharger shall submit an annual report no later than February 28 of each calendar year. Each annual report shall include at least the following information:
  - i. Brief description of treatment plant.** The description shall include the service area and treatment plant processes.
  - ii. Discussion of current pollutants of concern.** Periodically, the Discharger shall analyze its circumstances to determine which pollutants are currently a problem and which pollutants may be potential future problems. This discussion shall include the reasons for choosing the pollutants.
  - iii. Identification of sources for pollutants of concern.** This discussion shall include how the Discharger intends to estimate and identify pollutant sources. The Discharger shall include sources or potential sources not directly within the ability or authority of the Discharger to control, such as pollutants in the potable water supply and air deposition.

- iv. Identification of tasks to reduce the sources of pollutants of concern.** This discussion shall identify and prioritize tasks to address the Discharger's pollutants of concern. The Discharger may implement the tasks by itself or participate in group, regional, or national tasks that address its pollutants of concern. The Discharger is strongly encouraged to participate in group, regional, or national tasks that address its pollutants of concern whenever it is efficient and appropriate to do so. An implementation timeline shall be included for each task.
  - v. Outreach to employees.** The Discharger shall inform employees about the pollutants of concern, potential sources, and how they might be able to help reduce the discharge of these pollutants of concern into the Facility. The Discharger may provide a forum for employees to provide input.
  - vi. Continuation of Public Outreach Program.** The Discharger shall prepare a pollution prevention public outreach program for its service area. Outreach may include participation in existing community events, such as county fairs; initiating new community events, such as displays and contests during Pollution Prevention Week; conducting school outreach programs; conducting plant tours; and providing public information in newspaper articles or advertisements, radio or television stories or spots, newsletters, utility bill inserts, or websites. Information shall be specific to target audiences. The Discharger shall coordinate with other agencies as appropriate.
  - vii. Discussion of criteria used to measure Pollutant Minimization Program and task effectiveness.** The Discharger shall establish criteria to evaluate the effectiveness of its Pollutant Minimization Program. This discussion shall identify the specific criteria used to measure the effectiveness of each task in Provisions VI.C.3.b.iii, iv, v, and vi.
  - viii. Documentation of efforts and progress.** This discussion shall detail all of the Discharger's Pollutant Minimization Program activities during the reporting year.
  - ix. Evaluation of Pollutant Minimization Program and task effectiveness.** The Discharger shall use the criteria established in Provision VI.C.3.b.vii to evaluate the program and task effectiveness.
  - x. Identification of specific tasks and timelines for future efforts.** Based on the evaluation, the Discharger shall explain how it intends to continue or change its tasks to more effectively reduce the amount of pollutants flowing to the treatment plant, and subsequently in its effluent.
- c.** The Discharger shall develop and conduct a Pollutant Minimization Program as further described below when there is evidence that a priority pollutant is present in the effluent above an effluent limitation (e.g., sample results reported as detected but not quantified [DNQ] when the effluent limitation is less than the method detection limit [MDL], sample results from analytical methods more sensitive than those methods required by this Order, presence of whole effluent toxicity, health advisories for fish consumption, or results of benthic or aquatic organism tissue sampling) and either:

    - i.** A sample result is reported as DNQ and the effluent limitation is less than the Reporting Level (RL); or

- ii. A sample result is reported as not detected (ND) and the effluent limitation is less than the MDL, using definitions in Attachment A and reporting protocols described in the MRP.
  - d. If triggered by the reasons set forth in Provision VI.C.3.c, above, the Discharger's Pollutant Minimization Program shall include, but not be limited to, the following actions and submittals:
    - i. Annual review and semi-annual monitoring of potential sources of the reportable priority pollutants, which may include fish tissue monitoring and other bio-uptake sampling, or alternative measures when source monitoring is unlikely to produce useful analytical data;
    - ii. Quarterly monitoring for the reportable priority pollutants in the influent to the Facility. The Executive Officer may approve alternative measures when influent monitoring is unlikely to produce useful analytical data;
    - iii. Submittal of a control strategy designed to proceed toward the goal of maintaining concentrations of the reportable priority pollutants in the effluent at or below the effluent limitation;
    - iv. Implementation of appropriate cost-effective control measures for the reportable priority pollutants, consistent with the control strategy; and
    - v. Inclusion of the following specific items within the annual report required by Provision VI.C.3.b above:
      - (a) All Pollutant Minimization Program monitoring results for the previous year;
      - (b) List of potential sources of the reportable priority pollutants;
      - (c) Summary of all actions undertaken pursuant to the control strategy; and
      - (d) Description of actions to be taken in the following year.

#### 4. **Special Provisions for Publicly-Owned Treatment Works (POTWs)**

- a. **Pretreatment Program.** The Discharger shall implement and enforce its approved pretreatment program in accordance with federal pretreatment regulations (40 C.F.R. part 403); pretreatment standards promulgated under CWA sections 307(b), 307(c), and 307(d); pretreatment requirements specified under 40 C.F.R. section 122.44(j); and the requirements in Attachment H, "Pretreatment Requirements." The Discharger's responsibilities include, but are not limited to, the following:
  - i. Enforcement of the National Pretreatment Standards of 40 C.F.R. sections 403.5 and 403.6;
  - ii. Implementation of its pretreatment program in accordance with legal authorities, policies, procedures, and financial provisions described in the National Pretreatment Program (40 C.F.R. part 403);
  - iii. Submission of reports to the State Water Board and the Regional Water Board as described in Attachment H; and

- iv. Evaluation of the need to revise local limits under 40 C.F.R. section 403.5(c)(1) and, within 180 days following the effective date of this Order, submission of a report describing the changes, with a plan and schedule for implementation.

**b. Sludge and Biosolids Management**

- i. Sludge and biosolids treatment and storage shall not create a nuisance, such as objectionable odors or flies, or result in groundwater contamination.
- ii. Sludge and biosolids treatment and storage facilities shall be adequate to divert surface runoff from adjacent areas, to protect site boundaries from erosion, and to prevent conditions that would cause drainage from stored materials. Adequate protection is defined as protection from at least a 100-year storm and the highest possible tidal state that may occur.
- iii. This Order does not authorize permanent onsite sludge or biosolids storage or disposal. A Report of Waste Discharge shall be filed and the site brought into compliance with applicable regulations prior to commencement of any such activity.

**c. Collection System Management.** The Discharger is subject to the requirements of, and shall comply with, State Water Board Order No. 2006-0003-DWQ, Statewide General Waste Discharge Requirements for Sanitary Sewer Systems, as amended by State Water Board Order No. WQ 2013-0058-EXEC and any subsequent order updating these requirements.

**5. Other Special Provisions**

- a. **Specific Tasks to Reduce Wet Weather Bypasses.** The Discharger shall implement the following tasks to reduce wet weather bypasses of biological treatment:

**Table 5. Specific Tasks to Reduce Wet Weather Bypasses**

Task	Compliance Date
<p><b>1. Continue to Implement Wet Weather Improvement Plan</b>                      In cooperation with the Discharger’s satellite collection system agencies, continue to implement a comprehensive Wet Weather Improvement Plan that establishes measurable goals to minimize and eventually eliminate wet weather bypasses. The Plan shall specify operations, maintenance, and upgrades to be implemented by the Discharger and satellite collection system agencies. The Plan shall identify wet weather flow management procedures and collection systems maintenance and inspection schedules, necessary upgrades, and funding for scheduled maintenance and upgrades at the collection systems and treatment plant. The Discharger shall review the Plan annually and update as necessary.</p>	<p><i>Plan submitted                      November 26, 2013</i>                      Implementation shall be ongoing</p>
<p><b>2. Clean and Assess Condition of Collection System</b>                      Clean and perform CCTV inspection and document condition of Discharger’s collection system. When the Discharger inspects a sewer pipe, it shall also inspect all associated maintenance holes.</p>	<p>July 31, 2023</p>
<p><b>3. Rehabilitate High Priority Sewer Pipe</b>                      Complete at least \$18,000,000 of sewer pipe rehabilitation and improvements on Discharger’s collection system. When the Discharger rehabilitates a sewer pipe, it shall also rehabilitate, as needed, all associated maintenance holes and ensure that abandoned sewer laterals are not connected to the sewer main. The Discharger</p>	<p>July 31, 2023</p>

Task	Compliance Date
shall prioritize sewer pipe rehabilitation in areas known or suspected to have high inflow and infiltration.	
<p><b>4. Report Collection System Improvements Status</b>                      Report status of collection system improvements required in tasks 1, 2 and 3. The Discharger shall include, at a minimum, the unique feet and percent of sewer pipe cleaned, video inspected, and rehabilitated each year; dollars spent on sewer pipe rehabilitation each year; number of maintenance holes inspected and rehabilitated; number of abandoned sewer laterals found to be connected to the sewer main; and number of abandoned sewer laterals disconnected from the sewer main.</p>	Annually, with annual Self-Monitoring Report due February 1 each year
<p><b>5. Report Private Sewer Lateral Program Status</b>                      Report on the status and effectiveness of the Discharger’s private sewer lateral ordinance (Ordinance No. 1329, adopted in 1986 and modified by Ordinance No. 1623 in 2000). At a minimum, the Discharger shall report the number of private residences that triggered ordinance requirements and the number of those private sewer laterals inspected, those found to be in compliance, and those replaced or repaired.</p>	Annually, with annual Self-Monitoring Report due February 1 each year
<p><b>6. Ascertain Status of Satellite Collection System Agencies’ Capital Improvement Programs</b>                      Request information from the Town of Hillsborough and Burlingame Hills Sewer Maintenance District regarding their capital improvement activities conducted to reduce inflow and infiltration, including their implementation schedules and any significant changes to private sewer lateral programs.</p>	Annually, by November 1 each year
<p><b>7. Describe Status of Satellite Collection System Agencies’ Capital Improvement Programs</b>                      Report capital improvement activities conducted and planned to reduce infiltration and inflow based on information collected from the Town of Hillsborough and Burlingame Hills Sewer Maintenance District.</p>	Annually, with annual Self-Monitoring Report due February 1 each year
<p><b>8. Prepare Utility Analysis</b>                      If seeking to continue bypassing peak wet weather flows around the biological treatment units based on 40 C.F.R. 122.41(m)(4)(i)(A)-(C), complete a utility analysis that contains all elements described in part 1 of the No Feasible Alternatives Analysis Process in U.S. EPA’s proposed peak wet weather policy (<i>National Pollutant Discharge Elimination System Permit Requirements for Peak Wet Weather Discharges from Publicly Owned Treatment Works Treatment Plants Serving Separate Sanitary Sewer Collection Systems</i>, Fed. Reg. Vol. 70, No. 245, pages 76013-76018, December 22, 2005) and demonstrate that the Discharger has met the requirements for Regional Water Board approval pursuant to Attachment D section I.G.3. The submittal shall list and describe all feasible actions the Dischargers could implement during the next permit term. It shall also list and describe all feasible actions the satellite collection system agencies could implement as determined and provided by the satellite collection system agencies.</p>	With Report of Waste Discharge due November 1, 2022

**b. Copper Action Plan.** The Discharger shall implement pretreatment, source control, and pollution prevention for copper in accordance with the following tasks and time schedule:

**Table 6. Copper Action Plan**

Task	Compliance Date
<p><b>1. Implement Copper Control Program</b>                      Continue implementing existing program to reduce identified copper sources, including, as applicable, taking the following actions:</p> <ul style="list-style-type: none"> <li><b>a.</b> Providing education and outreach to the public (e.g., focusing on proper pool and spa maintenance and plumbers’ roles in reducing corrosion);</li> <li><b>b.</b> If corrosion is a significant copper source, working cooperatively with local</li> </ul>	Implementation shall be ongoing

Task	Compliance Date
<p>water purveyors to reduce and control water corrosivity, as appropriate, and ensuring that local plumbing contractors implement best management practices to reduce corrosion in pipes; and</p> <p>c. Educating plumbers, designers, and maintenance contractors for pools and spas to encourage best management practices that minimize copper discharges.</p>	
<p><b>2. Implement Additional Actions</b>                      If the Regional Water Board notifies the Discharger that the three-year rolling mean dissolved copper concentration in Central or Lower San Francisco Bay (north of Hayward Shoals) exceeds 2.2 µg/L, then within 90 days of the notification, evaluate the effluent copper concentration trend and, if it is increasing, develop and begin implementation of additional measures to control copper discharges. Report the conclusion of the trend analysis and provide a schedule for any new actions to be taken within the next 12 months.</p>	<p>With next annual pollution minimization program report due February 28 (at least 90 days following notification)</p>
<p><b>3. Report Status</b>                      Submit an annual report documenting copper control program implementation that evaluates the effectiveness of the actions taken, including any additional actions required by Task 2 above, and provides a schedule for actions to be taken within the next 12 months.</p>	<p>Annually, with annual pollution minimization program report due February 28 each year</p>

c. **Cyanide Action Plan.** The Discharger shall implement monitoring and surveillance, pretreatment, source control, and pollution prevention for cyanide in accordance with the following tasks and time schedule:

**Table 7. Cyanide Action Plan**

Task	Compliance Date
<p><b>1. Review Potential Cyanide Sources</b>                      Submit an up-to-date inventory of potential cyanide sources. If no cyanide source is identified, tasks 2 and 3, below, are not required unless the Discharger receives a request to discharge detectable levels of cyanide to the sewer. In this case, notify the Executive Officer and implement tasks 2 and 3.</p>	<p>With annual pollution minimization program report due February 28, 2019</p>
<p><b>2. Implement Cyanide Control Program</b>                      Implement a control program to minimize cyanide discharges consisting, at a minimum, of the following elements:</p> <ul style="list-style-type: none"> <li>a. Inspect each potential source to assess the need to include that source in the control program.</li> <li>b. Inspect sources included in the control program annually. Inspection elements may be based on U.S. EPA guidance, such as <i>Industrial User Inspection and Sampling Manual for POTWs</i> (EPA 831-B-94-01).</li> <li>c. Develop and distribute educational materials regarding the need to prevent cyanide discharges to sources included in the control program.</li> <li>d. Prepare an emergency monitoring and response plan to be implemented if a significant cyanide discharge occurs.</li> </ul> <p>If the plant influent cyanide concentration exceeds 16 µg/L, the Discharger shall collect a follow-up sample within 5 days of becoming aware of the laboratory results. If the results of the follow-up sample also exceed 16 µg/L, then a “significant cyanide discharge” is occurring.</p>	<p>Implementation shall be ongoing</p>
<p><b>3. Implement Additional Measures</b>                      If the Regional Water Board notifies the Discharger that ambient monitoring shows cyanide concentrations are 1.0 µg/L or higher in the main body of San Francisco Bay, then within 90 days of the notification, commence actions to identify and abate cyanide sources responsible for the elevated ambient concentrations, report on the progress and effectiveness of the actions taken, and provide a schedule for actions to be taken within the next 12 months.</p>	<p>With next annual pollution minimization program report due February 28 (at least 90 days following notification)</p>

Task	Compliance Date
<p><b>4. Report Status of Cyanide Control Program</b>                      Submit an annual report documenting cyanide control program implementation and addressing the effectiveness of actions taken, including any additional cyanide controls required by Task 3, above, and provide a schedule for actions to be taken within the next 12 months.</p>	<p>Annually, with annual pollution minimization program report due February 28 each year</p>

- d. Anaerobically-Digestible Material.** If the Discharger receives hauled-in anaerobically-digestible material for injection into an anaerobic digester, the Discharger shall notify the Regional Water Board and develop and implement Standard Operating Procedures for this activity. The Standard Operating Procedures shall be developed prior to initiation of hauling. The Standard Operating Procedures shall address material handling, including unloading, screening, or other processing prior to anaerobic digestion; transportation; spill prevention; spill response; avoidance of the introduction of materials that could cause interference, pass through, or upset of the treatment processes; avoidance of prohibited material; vector control; odor control; operation and maintenance; and the disposition of any solid waste segregated from introduction to the digester. The Discharger shall train its staff on the Standard Operating Procedures and maintain records for a minimum of three years for each load received, describing the hauler, waste type, and quantity received. In addition, the Discharger shall maintain records for a minimum of three years for the disposition, location, and quantity of cumulative pre-digestion segregated solid waste hauled offsite.
- e. Dilution Study.** The Discharger shall, by itself or in concert with other NBSU dischargers, undertake a new dilution study for the deepwater diffuser at Discharge Point No. 002 and submit the results with its application for permit reissuance. The study shall use a USEPA-approved modeling program, such as Visual PLUMES or CORMIX, and estimate the initial dilution at Discharge Point No. 002 for both the maximum wet-weather discharge and the average daily discharge. The Discharger shall estimate the initial dilutions just after slack tide under both peak wet weather and average daily flow scenarios.

## ATTACHMENT A – DEFINITIONS

### **Arithmetic Mean ( $\mu$ )**

Also called the average, the sum of measured values divided by the number of samples. For ambient water concentrations, the arithmetic mean is calculated as follows:

$$\text{Arithmetic mean} = \mu = \Sigma x / n \quad \text{where: } \Sigma x \text{ is the sum of the measured ambient water concentrations, and } n \text{ is the number of samples.}$$

### **Average Monthly Effluent Limitation (AMEL)**

The highest allowable average of daily discharges over a calendar month, calculated as the sum of all daily discharges measured during a calendar month divided by the number of daily discharges measured during that month.

### **Average Weekly Effluent Limitation (AWEL)**

The highest allowable average of daily discharges over a calendar week (Sunday through Saturday), calculated as the sum of all daily discharges measured during a calendar week divided by the number of daily discharges measured during that week.

### **Bioaccumulative**

Taken up by an organism from its surrounding medium through gill membranes, epithelial tissue, or from food and subsequently concentrated and retained in the body of the organism.

### **Carcinogenic**

Known to cause cancer in living organisms.

### **Coefficient of Variation**

Measure of data variability calculated as the estimated standard deviation divided by the arithmetic mean of the observed values.

### **Daily Discharge**

Either: (1) the total mass of the constituent discharged over the calendar day (12:00 am through 11:59 pm) or any 24-hour period that reasonably represents a calendar day for purposes of sampling (as specified in the permit) for a constituent with limitations expressed in units of mass; or (2) the unweighted arithmetic mean measurement of the constituent over the day for a constituent with limitations expressed in other units of measurement (e.g., concentration).

The daily discharge may be determined by the analytical results of a composite sample taken over the course of one day (a calendar day or other 24-hour period defined as a day) or by the arithmetic mean of analytical results from one or more grab samples taken over the course of the day.

For composite sampling, if 1 day is defined as a 24-hour period other than a calendar day, the analytical result for the 24-hour period is considered the result for the calendar day in which the 24-hour period ends.

### **Detected, but Not Quantified (DNQ)**

Sample result less than the RL, but greater than or equal to the laboratory's MDL. Sample results reported as DNQ are estimated concentrations.



### **Dilution Credit**

Amount of dilution granted to a discharge in the calculation of a water quality-based effluent limitation, based on the allowance of a specified mixing zone. It is calculated from the dilution ratio or determined by conducting a mixing zone study or modeling the discharge and receiving water.

### **Effluent Concentration Allowance (ECA)**

Value derived from the water quality criterion/objective, dilution credit, and ambient background concentration that is used, in conjunction with the CV for the effluent monitoring data, to calculate a long-term average (LTA) discharge concentration. The ECA has the same meaning as wasteload allocation (WLA) as used in U.S. EPA guidance (*Technical Support Document For Water Quality-based Toxics Control*, March 1991, second printing, EPA/505/2-90-001).

### **Enclosed Bay**

Indentation along the coast that encloses an area of oceanic water within a distinct headlands or harbor works. Enclosed bays include all bays where the narrowest distance between the headlands or outermost harbor works is less than 75 percent of the greatest dimension of the enclosed portion of the bay. Enclosed bays include, but are not limited to, Humboldt Bay, Bodega Harbor, Tomales Bay, Drake's Estero, San Francisco Bay, Morro Bay, Los Angeles-Long Beach Harbor, Upper and Lower Newport Bay, Mission Bay, and San Diego Bay. Enclosed bays do not include inland surface waters or ocean waters.

### **Estimated Chemical Concentration**

Concentration that results from the confirmed detection of the substance below the ML value by the analytical method.

### **Estuaries**

Waters, including coastal lagoons, located at the mouths of streams that serve as areas of mixing for fresh and ocean waters. Coastal lagoons and mouths of streams that are temporarily separated from the ocean by sandbars are considered estuaries. Estuarine waters are considered to extend from a bay or the open ocean to a point upstream where there is no significant mixing of fresh water and seawater. Estuarine waters include, but are not limited to, the Sacramento-San Joaquin Delta, as defined in Water Code section 12220, Suisun Bay, Carquinez Strait downstream to the Carquinez Bridge, and appropriate areas of the Smith, Mad, Eel, Noyo, Russian, Klamath, San Diego, and Otay rivers. Estuaries do not include inland surface waters or ocean waters.

### **Inland Surface Waters**

All surface waters of the state that do not include the ocean, enclosed bays, or estuaries.

### **Instantaneous Maximum Effluent Limitation**

Highest allowable value for any single grab sample or aliquot (i.e., each grab sample or aliquot is independently compared to the instantaneous maximum limitation).

### **Instantaneous Minimum Effluent Limitation**

Lowest allowable value for any single grab sample or aliquot (i.e., each grab sample or aliquot is independently compared to the instantaneous minimum limitation).

### **Maximum Daily Effluent Limitation (MDEL)**

Highest allowable daily discharge of a pollutant, over a calendar day (or 24-hour period). For pollutants with limitations expressed in units of mass, the daily discharge is calculated as the total mass of the pollutant discharged over the day. For pollutants with limitations expressed in other units of measurement, the daily discharge is calculated as the arithmetic mean measurement of the pollutant over the day.

### **Median**

Middle measurement in a set of data. The median of a set of data is found by first arranging the measurements in order of magnitude (either increasing or decreasing order). If the number of measurements ( $n$ ) is odd, then the median =  $X_{(n+1)/2}$ . If  $n$  is even, then the median =  $(X_{n/2} + X_{(n/2)+1})/2$  (i.e., the midpoint between  $n/2$  and  $n/2+1$ ).

### **Method Detection Limit (MDL)**

Minimum concentration of a substance that can be reported with 99 percent confidence that the measured concentration is distinguishable from method blank results, as defined in 40 C.F.R. part 136, Attachment B.

### **Minimum Level (ML)**

Concentration at which the entire analytical system gives a recognizable signal and acceptable calibration point. The ML is the concentration in a sample that is equivalent to the concentration of the lowest calibration standard analyzed by a specific analytical procedure, assuming that all the method specified sample weights, volumes, and processing steps have been followed.

### **Mixing Zone**

Limited volume of receiving water allocated for mixing with a wastewater discharge where water quality criteria can be exceeded without causing adverse effects to the overall water body.

### **Not Detected (ND)**

Sample results less than the laboratory's MDL.

### **Persistent Pollutants**

Substances for which degradation or decomposition in the environment is nonexistent or very slow.

### **Pollutant Minimization Program**

Program of waste minimization and pollution prevention actions that include, but are not limited to, product substitution, waste stream recycling, alternative waste management methods, and education of the public and businesses. The goal of the Pollutant Minimization Program is to reduce all potential sources of a priority pollutant through pollutant minimization (control) strategies, including pollution prevention measures as appropriate, to maintain the effluent concentration at or below the water quality-based effluent limitation. Pollution prevention measures may be particularly appropriate for persistent bioaccumulative priority pollutants where there is evidence that beneficial uses are being impacted. Cost effectiveness may be considered when establishing the requirements of a Pollutant Minimization Program. The completion and implementation of a Pollution Prevention Plan, if required pursuant to Water Code section 13263.3(d), is considered to fulfill Pollutant Minimization Program requirements.

### **Pollution Prevention**

Any action that causes a net reduction in the use or generation of a hazardous substance or other pollutant that is discharged into water and includes, but is not limited to, input change, operational improvement, production process change, and product reformulation (as defined in Water Code section 13263.3). Pollution prevention does not include actions that merely shift a pollutant in wastewater from one environmental medium to another environmental medium, unless clear environmental benefits of such an approach are identified to the satisfaction of the State Water Board or Regional Water Board.

### **Reporting Level (RL)**

ML (and its associated analytical method) chosen by the Discharger for reporting and compliance determination from the MLs included in this Order, including an additional factor if applicable as discussed herein. The MLs included in this Order correspond to approved analytical methods for reporting a sample result that are selected by the Regional Water Board either from SIP Appendix 4 in accordance with SIP section 2.4.2 or established in accordance with SIP section 2.4.3. The ML is based on the proper application of method-based analytical procedures for sample preparation and the absence of any matrix interferences. Other factors may be applied to the ML depending on the specific sample preparation steps employed. For example, the treatment typically applied in cases where there are matrix-effects is to dilute the sample or sample aliquot by a factor of ten. In such cases, this additional factor must be applied to the ML in the computation of the RL.

### **Source of Drinking Water**

Any water designated as having a municipal or domestic supply (MUN) beneficial use.

### **Standard Deviation ( $\sigma$ )**

Measure of variability calculated as follows:

$$\sigma = \left( \frac{\sum[(x - \mu)^2]}{(n - 1)} \right)^{0.5}$$

where:

x is the observed value;

$\mu$  is the arithmetic mean of the observed values; and

n is the number of samples.

### **Toxicity Reduction Evaluation (TRE)**

Study conducted in a step-wise process designed to identify the causative agents of effluent or ambient toxicity, isolate the sources of toxicity, evaluate the effectiveness of toxicity control options, and then confirm the reduction in toxicity. The first steps of the TRE consist of the collection of data relevant to the toxicity, including additional toxicity testing, and an evaluation of facility operations and maintenance practices, and best management practices. A Toxicity Identification Evaluation (TIE) may be required as part of the TRE, if appropriate. A TIE is a set of procedures to identify the specific chemicals responsible for toxicity. These procedures are performed in three phases (characterization, identification, and confirmation) using aquatic organism toxicity tests.

### ATTACHMENT B – FACILITY MAPS





**ATTACHMENT C – PROCESS FLOW DIAGRAM**

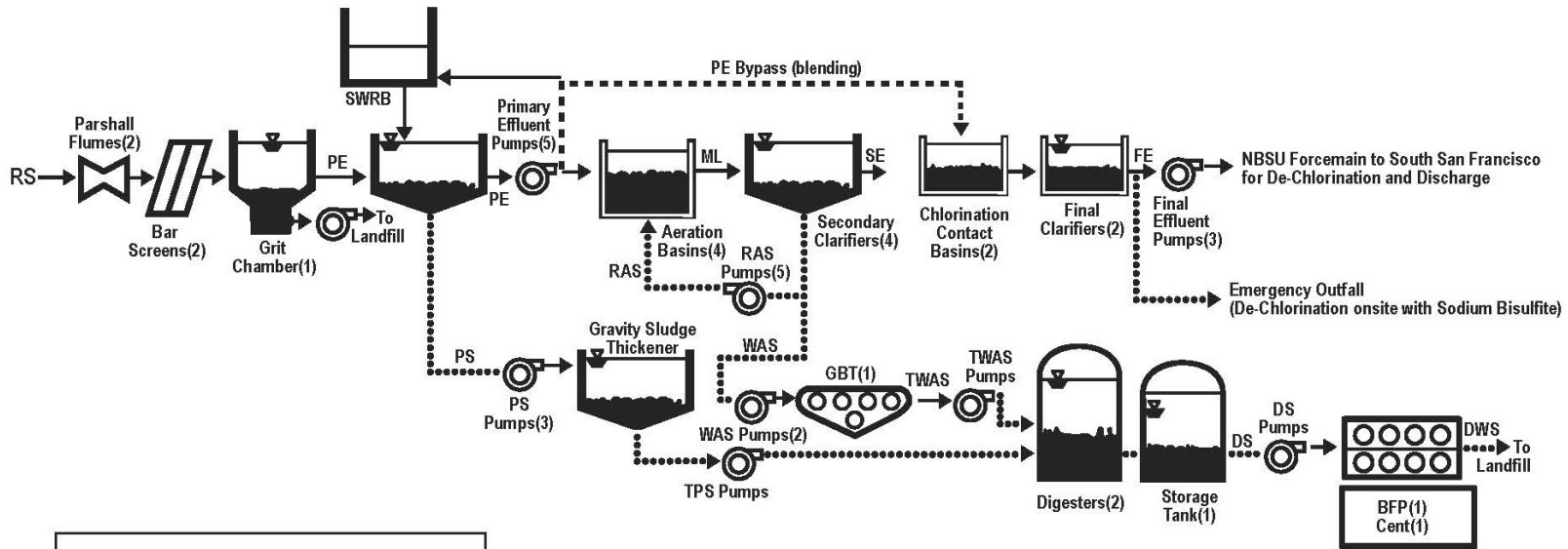

LEGEND	
RS	Raw Sewage
PE	Primary Effluent
ML	Mixed Liquor
SE	Secondary Effluent
FE	Final Effluent
PS	Primary Sludge
TPS	Thickened Primary Sludge
RAS	Return Activated Sludge
WAS	Waste Activated Sludge
TWAS	Thickened Waste Activated Sludge
SWRB	Storm Water Retention Basin
GBT	Gravity Belt Thickener
BFP	Belt Filter Press
Cent	Centrifuge
DS	Digested Sludge
DWS	Dewatered Sludge
NBSU	North Bayside System Unit
—	Liquid Stream
.....	Solids Stream
- - - -	Bypass Stream
()	Number of Units

## **ATTACHMENT D –STANDARD PROVISIONS**

### **I. STANDARD PROVISIONS—PERMIT COMPLIANCE**

#### **A. Duty to Comply**

1. The Discharger must comply with all of the terms, requirements, and conditions of this Order. Any noncompliance constitutes a violation of the Clean Water Act (CWA) and the California Water Code and is grounds for enforcement action; for permit termination, revocation and reissuance, or modification; or denial of a permit renewal application; or a combination thereof. (40 C.F.R. § 122.41(a); Wat. Code §§ 13261, 13263, 13265, 13268, 13000, 13001, 13304, 13350, 13385.)
2. The Discharger shall comply with effluent standards or prohibitions established under CWA section 307(a) for toxic pollutants within the time provided in the regulations that establish these standards or prohibitions, even if this Order has not yet been modified to incorporate the requirement. (40 C.F.R. § 122.41(a)(1).)

#### **B. Need to Halt or Reduce Activity Not a Defense**

It shall not be a defense for a Discharger in an enforcement action that it would have been necessary to halt or reduce the permitted activity in order to maintain compliance with the conditions of this Order. (40 C.F.R. § 122.41(c).)

#### **C. Duty to Mitigate**

The Discharger shall take all reasonable steps to minimize or prevent any discharge in violation of this Order that has a reasonable likelihood of adversely affecting human health or the environment. (40 C.F.R. § 122.41(d).)

#### **D. Proper Operation and Maintenance**

The Discharger shall at all times properly operate and maintain all facilities and systems of treatment and control (and related appurtenances) which are installed or used by the Discharger to achieve compliance with the conditions of this Order. Proper operation and maintenance also includes adequate laboratory controls and appropriate quality assurance procedures. This provision requires the operation of backup or auxiliary facilities or similar systems that are installed by a Discharger only when necessary to achieve compliance with the conditions of this Order. (40 C.F.R. § 122.41(e).)

#### **E. Property Rights**

1. This Order does not convey any property rights of any sort or any exclusive privileges. (40 C.F.R. § 122.41(g).)
2. The issuance of this Order does not authorize any injury to persons or property or invasion of other private rights, or any infringement of state or local law or regulations. (40 C.F.R. § 122.5(c).)

## F. Inspection and Entry

The Discharger shall allow the Regional Water Board, State Water Board, U.S. EPA, or their authorized representatives (including an authorized contractor acting as their representative), upon the presentation of credentials and other documents, as may be required by law, to (33 U.S.C. § 1318(a)(4)(B); 40 C.F.R. § 122.41(i); Wat. Code, §§ 13267, 13383):

1. Enter upon the Discharger's premises where a regulated facility or activity is located or conducted, or where records are kept under the conditions of this Order (33 U.S.C. § 1318(a)(4)(B)(i); 40 C.F.R. § 122.41(i)(1); Wat. Code, §§ 13267, 13383);
2. Have access to and copy, at reasonable times, any records that must be kept under the conditions of this Order (33 U.S.C. § 1318(a)(4)(B)(ii); 40 C.F.R. § 122.41(i)(2); Wat. Code, §§ 13267, 13383);
3. Inspect and photograph, at reasonable times, any facilities, equipment (including monitoring and control equipment), practices, or operations regulated or required under this Order (33 U.S.C. § 1318(a)(4)(B)(ii); 40 C.F.R. § 122.41(i)(3); Wat. Code, §§ 13267, 13383); and
4. Sample or monitor, at reasonable times, for the purposes of assuring Order compliance or as otherwise authorized by the CWA or the Water Code, any substances or parameters at any location. (33 U.S.C. § 1318(a)(4)(B); 40 C.F.R. § 122.41(i)(4); Wat. Code, 13267, 13383.)

## G. Bypass

### 1. Definitions

- a. “Bypass” means the intentional diversion of waste streams from any portion of a treatment facility. (40 C.F.R. § 122.41(m)(1)(i).)
- b. “Severe property damage” means substantial physical damage to property, damage to the treatment facilities, which causes them to become inoperable, or substantial and permanent loss of natural resources that can reasonably be expected to occur in the absence of a bypass. Severe property damage does not mean economic loss caused by delays in production. (40 C.F.R. § 122.41(m)(1)(ii).)

2. **Bypass not exceeding limitations.** The Discharger may allow any bypass to occur which does not cause exceedances of effluent limitations, but only if it is for essential maintenance to assure efficient operation. These bypasses are not subject to the provisions listed in Standard Provisions – Permit Compliance I.G.3, I.G.4, and I.G.5 below. (40 C.F.R. § 122.41(m)(2).)

3. **Prohibition of bypass.** Bypass is prohibited, and the Regional Water Board may take enforcement action against a Discharger for bypass, unless (40 C.F.R. § 122.41(m)(4)(i)):

- a. Bypass was unavoidable to prevent loss of life, personal injury, or severe property damage (40 C.F.R. § 122.41(m)(4)(i)(A));
- b. There were no feasible alternatives to the bypass, such as the use of auxiliary treatment facilities, retention of untreated wastes, or maintenance during normal periods of equipment downtime. This condition is not satisfied if adequate back-up equipment



should have been installed in the exercise of reasonable engineering judgment to prevent a bypass that occurred during normal periods of equipment downtime or preventive maintenance (40 C.F.R. § 122.41(m)(4)(i)(B)); and

c. The Discharger submitted notice to the Regional Water Board as required under Standard Provisions – Permit Compliance I.G.5 below. (40 C.F.R. § 122.41(m)(4)(i)(C).)

4. **Approval.** The Regional Water Board may approve an anticipated bypass, after considering its adverse effects, if the Regional Water Board determines that it will meet the three conditions listed in Standard Provisions—Permit Compliance I.G.3 above. (40 C.F.R. § 122.41(m)(4)(ii).)

#### 5. Notice

a. **Anticipated bypass.** If the Discharger knows in advance of the need for a bypass, it shall submit prior notice, if possible at least 10 days before the date of the bypass. The notice shall be sent to the Regional Water Board. As of December 21, 2020, a notice shall also be submitted electronically to the initial recipient defined in Standard Provisions – Reporting V.J below. Notices shall comply with 40 C.F.R. part 3, 40 C.F.R. section 122.22, and 40 C.F.R. part 127. (40 C.F.R. § 122.41(m)(3)(i).)

b. **Unanticipated bypass.** The Discharger shall submit a notice of an unanticipated bypass as required in Standard Provisions - Reporting V.E below (24-hour notice). The notice shall be sent to the Regional Water Board. As of December 21, 2020, a notice shall also be submitted electronically to the initial recipient defined in Standard Provisions – Reporting V.J below. Notices shall comply with 40 C.F.R. part 3, 40 C.F.R. section 122.22, and 40 C.F.R. part 127. (40 C.F.R. § 122.41(m)(3)(ii).)

#### H. Upset

Upset means an exceptional incident in which there is unintentional and temporary noncompliance with technology based permit effluent limitations because of factors beyond the reasonable control of the Discharger. An upset does not include noncompliance to the extent caused by operational error, improperly designed treatment facilities, inadequate treatment facilities, lack of preventive maintenance, or careless or improper operation. (40 C.F.R. § 122.41(n)(1).)

1. **Effect of an upset.** An upset constitutes an affirmative defense to an action brought for noncompliance with such technology based permit effluent limitations if the requirements of Standard Provisions – Permit Compliance I.H.2 below are met. No determination made during administrative review of claims that noncompliance was caused by upset, and before an action for noncompliance, is final administrative action subject to judicial review. (40 C.F.R. § 122.41(n)(2).)

2. **Conditions necessary for a demonstration of upset.** A discharger who wishes to establish the affirmative defense of upset shall demonstrate, through properly signed, contemporaneous operating logs or other relevant evidence that (40 C.F.R. § 122.41(n)(3)):

a. An upset occurred and that the Discharger can identify the cause(s) of the upset (40 C.F.R. § 122.41(n)(3)(i));

- b. The permitted facility was, at the time, being properly operated (40 C.F.R. § 122.41(n)(3)(ii));
  - c. The Discharger submitted notice of the upset as required in Standard Provisions—Reporting V.E.2.b below (24-hour notice) (40 C.F.R. § 122.41(n)(3)(iii)); and
  - d. The Discharger complied with any remedial measures required under Standard Provisions—Permit Compliance I.C above. (40 C.F.R. § 122.41(n)(3)(iv).)
3. **Burden of proof.** In any enforcement proceeding, the Discharger seeking to establish the occurrence of an upset has the burden of proof. (40 C.F.R. § 122.41(n)(4).)

## II. STANDARD PROVISIONS—PERMIT ACTION

### A. General

This Order may be modified, revoked and reissued, or terminated for cause. The filing of a request by the Discharger for modification, revocation and reissuance, or termination, or a notification of planned changes or anticipated noncompliance does not stay any Order condition. (40 C.F.R. § 122.41(f).)

### B. Duty to Reapply

If the Discharger wishes to continue an activity regulated by this Order after the expiration date of this Order, the Discharger must apply for and obtain a new permit. (40 C.F.R. § 122.41(b).)

### C. Transfers

This Order is not transferable to any person except after notice to the Regional Water Board. The Regional Water Board may require modification or revocation and reissuance of the Order to change the name of the Discharger and incorporate such other requirements as may be necessary under the CWA and the Water Code. (40 C.F.R. §§ 122.41(1)(3), 122.61.)

## III. STANDARD PROVISIONS—MONITORING

- A. Samples and measurements taken for the purpose of monitoring shall be representative of the monitored activity. (40 C.F.R. § 122.41(j)(1).)
- B. Monitoring must be conducted according to test procedures approved under 40 C.F.R. part 136 for the analyses of pollutants unless another method is required under 40 C.F.R. chapter 1, subchapter N. Monitoring must be conducted according to sufficiently sensitive test methods approved under 40 C.F.R. part 136 for the analysis of pollutants or pollutant parameters or required under 40 C.F.R. chapter 1, subchapter N. For the purposes of this paragraph, a method is sufficiently sensitive when:
  1. The method minimum level (ML) is at or below the level of the effluent limitation established in the permit for the measured pollutant or pollutant parameter, and either (a) the method ML is at or below the level of the applicable water quality criterion for the measured pollutant or pollutant parameter, or (b) the method ML is above the applicable water quality criterion but the amount of the pollutant or pollutant parameter in a facility's discharge is

high enough that the method detects and quantifies the level of the pollutant or pollutant parameter in the discharge; or

2. The method has the lowest ML of the analytical methods approved under 40 C.F.R. part 136 or required under 40 C.F.R. chapter 1, subchapter N, for the measured pollutant or pollutant parameter.

In the case of pollutants or pollutant parameters for which there are no approved methods under 40 C.F.R. part 136 or otherwise required under 40 C.F.R. chapter 1, subchapter N, monitoring must be conducted according to a test procedure specified in this Order for such pollutants or pollutant parameters. (40 C.F.R. §§ 122.21(e)(3), 122.41(j)(4), 122.44(i)(1)(iv).)

#### **IV. STANDARD PROVISIONS—RECORDS**

- A. The Discharger shall retain records of all monitoring information, including all calibration and maintenance records and all original strip chart recordings for continuous monitoring instrumentation, copies of all reports required by this Order, and records of all data used to complete the application for this Order, for a period of at least three (3) years from the date of the sample, measurement, report or application. This period may be extended by request of the Regional Water Board Executive Officer at any time. (40 C.F.R. § 122.41(j)(2).)
- B. Records of monitoring information shall include the following:
  1. The date, exact place, and time of sampling or measurements (40 C.F.R. § 122.41(j)(3)(i));
  2. The individual(s) who performed the sampling or measurements (40 C.F.R. § 122.41(j)(3)(ii));
  3. The date(s) the analyses were performed (40 C.F.R. § 122.41(j)(3)(iii));
  4. The individual(s) who performed the analyses (40 C.F.R. § 122.41(j)(3)(iv));
  5. The analytical techniques or methods used (40 C.F.R. § 122.41(j)(3)(v)); and
  6. The results of such analyses. (40 C.F.R. § 122.41(j)(3)(vi).)
- C. Claims of confidentiality for the following information will be denied (40 C.F.R. § 122.7(b)):
  1. The name and address of any permit applicant or Discharger (40 C.F.R. § 122.7(b)(1)); and
  2. Permit applications and attachments, permits, and effluent data. (40 C.F.R. § 122.7(b)(2).)

#### **V. STANDARD PROVISIONS—REPORTING**

##### **A. Duty to Provide Information**

The Discharger shall furnish to the Regional Water Board, State Water Board, or U.S. EPA within a reasonable time, any information which the Regional Water Board, State Water Board, or U.S. EPA may request to determine whether cause exists for modifying, revoking and reissuing, or terminating this Order or to determine compliance with this Order. Upon request, the Discharger

shall also furnish to the Regional Water Board, State Water Board, or U.S. EPA copies of records required to be kept by this Order. (40 C.F.R. § 122.41(h); Wat. Code, §§ 13267, 13383.)

## **B. Signatory and Certification Requirements**

1. All applications, reports, or information submitted to the Regional Water Board, State Water Board, and/or U.S. EPA shall be signed and certified in accordance with Standard Provisions—Reporting V.B.2, V.B.3, V.B.4, V.B.5, and V.B.6 below. (40 C.F.R. § 122.41(k).)
2. For a corporation, all permit applications shall be signed by a responsible corporate officer. For the purpose of this section, a responsible corporate officer means: (i) a president, secretary, treasurer, or vice-president of the corporation in charge of a principal business function, or any other person who performs similar policy- or decision-making functions for the corporation, or (ii) the manager of one or more manufacturing, production, or operating facilities, provided, the manager is authorized to make management decisions which govern the operation of the regulated facility including having the explicit or implicit duty of making major capital investment recommendations, and initiating and directing other comprehensive measures to assure long term environmental compliance with environmental laws and regulations; the manager can ensure that the necessary systems are established or actions taken to gather complete and accurate information for permit application requirements; and where authority to sign documents has been assigned or delegated to the manager in accordance with corporate procedures. (40 C.F.R. § 122.22(a)(1).)

For a partnership or sole proprietorship, all permit applications shall be signed by a general partner or the proprietor, respectively. (40 C.F.R. § 122.22(a)(2).)

For a municipality, State, federal, or other public agency, all permit applications shall be signed by either a principal executive officer or ranking elected official. For purposes of this provision, a principal executive officer of a federal agency includes (i) the chief executive officer of the agency, or (ii) a senior executive officer having responsibility for the overall operations of a principal geographic unit of the agency (e.g., Regional Administrators of U.S. EPA). (40 C.F.R. § 122.22(a)(3).)

3. All reports required by this Order and other information requested by the Regional Water Board, State Water Board, or U.S. EPA shall be signed by a person described in Standard Provisions – Reporting V.B.2 above, or by a duly authorized representative of that person. A person is a duly authorized representative only if:
  - a. The authorization is made in writing by a person described in Standard Provisions—Reporting V.B.2 above (40 C.F.R. § 122.22(b)(1));
  - b. The authorization specifies either an individual or a position having responsibility for the overall operation of the regulated facility or activity such as the position of plant manager, operator of a well or a well field, superintendent, position of equivalent responsibility, or an individual or position having overall responsibility for environmental matters for the company. (A duly authorized representative may thus be either a named individual or any individual occupying a named position.) (40 C.F.R. § 122.22(b)(2)); and

- c. The written authorization is submitted to the Regional Water Board and State Water Board. (40 C.F.R. § 122.22(b)(3).)
4. If an authorization under Standard Provisions – Reporting V.B.3 above is no longer accurate because a different individual or position has responsibility for the overall operation of the facility, a new authorization satisfying the requirements of Standard Provisions—Reporting V.B.3 above must be submitted to the Regional Water Board and State Water Board prior to or together with any reports, information, or applications, to be signed by an authorized representative. (40 C.F.R. § 122.22(c).)
5. Any person signing a document under Standard Provisions—Reporting V.B.2 or V.B.3 above shall make the following certification:

“I certify under penalty of law that this document and all attachments were prepared under my direction or supervision in accordance with a system designed to assure that qualified personnel properly gather and evaluate the information submitted. Based on my inquiry of the person or persons who manage the system or those persons directly responsible for gathering the information, the information submitted is, to the best of my knowledge and belief, true, accurate, and complete. I am aware that there are significant penalties for submitting false information, including the possibility of fine and imprisonment for knowing violations.” (40 C.F.R. § 122.22(d).)
6. Any person providing the electronic signature for documents described in Standard Provisions – V.B.1, V.B.2, or V.B.3 that are submitted electronically shall meet all relevant requirements of Standard Provisions – Reporting V.B, and shall ensure that all relevant requirements of 40 C.F.R. part 3 (Cross-Media Electronic Reporting) and 40 C.F.R. part 127 (NPDES Electronic Reporting Requirements) are met for that submission. (40 C.F.R § 122.22(e).)

### **C. Monitoring Reports**

1. Monitoring results shall be reported at the intervals specified in the Monitoring and Reporting Program in this Order. (40 C.F.R. § 122.22(l)(4).)
2. Monitoring results must be reported on a Discharge Monitoring Report (DMR) form or forms provided or specified by the Regional Water Board or State Water Board. As of December 21, 2016, all reports and forms must be submitted electronically to the initial recipient defined in Standard Provisions – Reporting V.J and comply with 40 C.F.R. part 3, 40 C.F.R. section 122.22, and 40 C.F.R. part 127. (40 C.F.R. § 122.41(l)(4)(i).)
3. If the Discharger monitors any pollutant more frequently than required by this Order using test procedures approved under 40 C.F.R. part 136, or another method required for an industry-specific waste stream under 40 C.F.R. chapter 1, subchapter N, the results of such monitoring shall be included in the calculation and reporting of the data submitted in the DMR reporting form specified by the Regional Water Board or State Water Board. (40 C.F.R. § 122.41(l)(4)(ii).)
4. Calculations for all limitations, which require averaging of measurements, shall utilize an arithmetic mean unless otherwise specified in this Order. (40 C.F.R. § 122.41(l)(4)(iii).)

#### **D. Compliance Schedules**

Reports of compliance or noncompliance with, or any progress reports on, interim and final requirements contained in any compliance schedule of this Order, shall be submitted no later than 14 days following each schedule date. (40 C.F.R. § 122.41(l)(5).)

#### **E. Twenty-Four Hour Reporting**

1. The Discharger shall report any noncompliance that may endanger health or the environment. Any information shall be provided orally within 24 hours from the time the Discharger becomes aware of the circumstances. A written report shall also be provided within five (5) days of the time the Discharger becomes aware of the circumstances. The report shall contain a description of the noncompliance and its cause; the period of noncompliance, including exact dates and times, and if the noncompliance has not been corrected, the anticipated time it is expected to continue; and steps taken or planned to reduce, eliminate, and prevent reoccurrence of the noncompliance.

For noncompliance related to combined sewer overflows, sanitary sewer overflows, or bypass events, these reports must include the data described above (with the exception of time of discovery) as well as the type of event (i.e., combined sewer overflow, sanitary sewer overflow, or bypass event), type of overflow structure (e.g., manhole, combined sewer overflow outfall), discharge volume untreated by the treatment works treating domestic sewage, types of human health and environmental impacts of the event, and whether the noncompliance was related to wet weather.

As of December 21, 2020, all reports related to combined sewer overflows, sanitary sewer overflows, or bypass events must be submitted to the Regional Water Board and must be submitted electronically to the initial recipient defined in Standard Provisions – Reporting V.J. The reports shall comply with 40 C.F.R. part 3, 40 C.F.R. section 122.22, and 40 C.F.R. part 127. The Regional Water Board may also require the Discharger to electronically submit reports not related to combined sewer overflows, sanitary sewer overflows, or bypass events under this section. (40 C.F.R. § 122.41(l)(6)(i).)

2. The following shall be included as information that must be reported within 24 hours:
  - a. Any unanticipated bypass that exceeds any effluent limitation in this Order. (40 C.F.R. § 122.41(l)(6)(ii)(A).)
  - b. Any upset that exceeds any effluent limitation in this Order. (40 C.F.R. § 122.41(l)(6)(ii)(B).)
3. The Regional Water Board may waive the above-required written report under this provision on a case-by-case basis if an oral report has been received within 24 hours. (40 C.F.R. § 122.41(l)(6)(iii).)

#### **F. Planned Changes**

The Discharger shall give notice to the Regional Water Board as soon as possible of any planned physical alterations or additions to the permitted facility. Notice is required under this provision only when (40 C.F.R. § 122.41(l)(1)):

1. The alteration or addition to a permitted facility may meet one of the criteria for determining whether a facility is a new source in 40 C.F.R. section 122.29(b) (40 C.F.R. § 122.41(l)(1)(i)); or
2. The alteration or addition could significantly change the nature or increase the quantity of pollutants discharged. This notification applies to pollutants that are not subject to effluent limitations in this Order. (Alternatively, for an existing manufacturing, commercial, mining, or silvicultural discharge as referenced in 40 C.F.R. section 122.42(a), this notification applies to pollutants that are subject neither to effluent limitations in this Order nor to notification requirements under 40 C.F.R. section 122.42(a)(1) (see Additional Provisions—Notification Levels VII.A.1).) (40 C.F.R. § 122.41(l)(1)(ii).)

### **G. Anticipated Noncompliance**

The Discharger shall give advance notice to the Regional Water Board or State Water Board of any planned changes in the permitted facility or activity that may result in noncompliance with this Order's requirements. (40 C.F.R. § 122.41(l)(2).)

### **H. Other Noncompliance**

The Discharger shall report all instances of noncompliance not reported under Standard Provisions—Reporting V.C, V.D, and V.E above at the time monitoring reports are submitted. The reports shall contain the information listed in Standard Provision—Reporting V.E above. For noncompliance related to combined sewer overflows, sanitary sewer overflows, or bypass events, these reports shall contain the information described in Standard Provision – Reporting V.E and the applicable required data in appendix A to 40 C.F.R. part 127. The Regional Water Board may also require the Discharger to electronically submit reports not related to combined sewer overflows, sanitary sewer overflows, or bypass events under this section. (40 C.F.R. § 122.41(l)(7).)

### **I. Other Information**

When the Discharger becomes aware that it failed to submit any relevant facts in a permit application, or submitted incorrect information in a permit application or in any report to the Regional Water Board, State Water Board, or U.S. EPA, the Discharger shall promptly submit such facts or information. (40 C.F.R. § 122.41(l)(8).)

### **J. Initial Recipient for Electronic Reporting Data**

The owner, operator, or duly authorized representative is required to electronically submit NPDES information specified in appendix A to 40 C.F.R. part 127 to the initial recipient defined in 40 C.F.R. section 127.2(b). U.S. EPA will identify and publish the list of initial recipients on its website and in the Federal Register, by state and by NPDES data group [see 40 C.F.R. § 127.2(c)]. U.S. EPA will update and maintain this list. (40 C.F.R. § 122.41(l)(9).)

## **VI. STANDARD PROVISIONS—ENFORCEMENT**

- A. The Regional Water Board is authorized to enforce the terms of this Order under several provisions of the Water Code, including, but not limited to, sections 13268, 13350, 13385, 13386, and 13387.

## VII. ADDITIONAL PROVISIONS—NOTIFICATION LEVELS

### A. Non-Municipal Facilities

Existing manufacturing, commercial, mining, and silvicultural dischargers shall notify the Regional Water Board as soon as they know or have reason to believe (40 C.F.R. § 122.42(a)):

1. That any activity has occurred or will occur that would result in the discharge, on a routine or frequent basis, of any toxic pollutant that is not limited in this Order, if that discharge will exceed the highest of the following “notification levels” (40 C.F.R. § 122.42(a)(1)):
  - a. 100 micrograms per liter ( $\mu\text{g/L}$ ) (40 C.F.R. § 122.42(a)(1)(i));
  - b. 200  $\mu\text{g/L}$  for acrolein and acrylonitrile; 500  $\mu\text{g/L}$  for 2,4-dinitrophenol and 2-methyl-4,6-dinitrophenol; and 1 milligram per liter ( $\text{mg/L}$ ) for antimony (40 C.F.R. § 122.42(a)(1)(ii));
  - c. Five (5) times the maximum concentration value reported for that pollutant in the Report of Waste Discharge (40 C.F.R. § 122.42(a)(1)(iii)); or
  - d. The level established by the Regional Water Board in accordance with section 122.44(f). (40 C.F.R. § 122.42(a)(1)(iv).)
2. That any activity has occurred or will occur that would result in the discharge, on a non-routine or infrequent basis, of any toxic pollutant that is not limited in this Order, if that discharge will exceed the highest of the following “notification levels” (40 C.F.R. § 122.42(a)(2)):
  - a. 500 micrograms per liter ( $\mu\text{g/L}$ ) (40 C.F.R. § 122.42(a)(2)(i));
  - b. 1 milligram per liter ( $\text{mg/L}$ ) for antimony (40 C.F.R. § 122.42(a)(2)(ii));
  - c. Ten (10) times the maximum concentration value reported for that pollutant in the Report of Waste Discharge (40 C.F.R. § 122.42(a)(2)(iii)); or
  - d. The level established by the Regional Water Board in accordance with section 122.44(f). (40 C.F.R. § 122.42(a)(2)(iv).)

### B. Publicly-Owned Treatment Works (POTWs)

All POTWs shall provide adequate notice to the Regional Water Board of the following (40 C.F.R. § 122.42(b)):

1. Any new introduction of pollutants into the POTW from an indirect discharger that would be subject to CWA sections 301 or 306 if it were directly discharging those pollutants (40 C.F.R. § 122.42(b)(1)); and
2. Any substantial change in the volume or character of pollutants being introduced into that POTW by a source introducing pollutants into the POTW at the time of adoption of this Order. (40 C.F.R. § 122.42(b)(2).)



3. Adequate notice shall include information on the quality and quantity of effluent introduced into the POTW as well as any anticipated impact of the change on the quantity or quality of effluent to be discharged from the POTW. (40 C.F.R. § 122.42(b)(3).)

## ATTACHMENT E – MONITORING AND REPORTING PROGRAM (MRP)

### Contents

I.	General Monitoring Provisions.....	E-2
II.	Monitoring Locations.....	E-2
III.	Influent Monitoring Requirements .....	E-3
IV.	Effluent Monitoring Requirements .....	E-3
V.	Toxicity Testing Requirements.....	E-6
	A. Acute Toxicity .....	E-6
	B. Chronic Toxicity.....	E-7
VI.	Receiving Water Monitoring Requirements .....	E-10
VII.	Pretreatment and Biosolids Monitoring Requirements .....	E-10
VIII.	Reporting Requirements .....	E-11
	A. General Monitoring and Reporting Requirements .....	E-11
	B. Self-Monitoring Reports (SMRs).....	E-11
	C. Discharge Monitoring Reports (DMRs).....	E-14

### Tables

Table E-1.	Monitoring Locations.....	E-2
Table E-2.	Influent Monitoring.....	E-3
Table E-3.	Effluent Monitoring—Routine.....	E-4
Table E-4.	Effluent Monitoring—Blending.....	E-5
Table E-5.	Pretreatment and Biosolids Monitoring .....	E-10
Table E-6.	CIWQS Reporting.....	E-12
Table E-7.	Monitoring Periods .....	E-13

**ATTACHMENT E – MONITORING AND REPORTING PROGRAM (MRP)**

Clean Water Act section 308 and 40 C.F.R. sections 122.41(h), 122.41(j)-(l), 122.44(i), and 122.48 require that all NPDES permits specify monitoring and reporting requirements. Water Code sections 13267 and 13383 also authorize the Regional Water Board to establish monitoring, inspection, entry, reporting, and recordkeeping requirements. This MRP establishes monitoring, reporting, and recordkeeping requirements that implement federal and State laws and regulations.

**I. GENERAL MONITORING PROVISIONS**

- A. The Discharger shall comply with this MRP. The Executive Officer may amend this MRP pursuant to 40 C.F.R. sections 122.62, 122.63, and 124.5. If any discrepancies exist between this MRP and the “Regional Standard Provisions, and Monitoring and Reporting Requirements (Supplement to Attachment D) for NPDES Wastewater Discharge Permits” (Attachment G), this MRP shall prevail.
- B. The Discharger shall conduct all monitoring in accordance with Attachment D, section III, as supplemented by Attachment G. Equivalent test methods must be more sensitive than those specified in 40 C.F.R. section 136 and must be specified in this permit.
- C. The Discharger shall ensure that results of the Discharge Monitoring Report-Quality Assurance (DMR-QA) Study or most recent Water Pollution Performance Evaluation Study are submitted annually to the State Water Board at the following address:  
 State Water Resources Control Board  
 Quality Assurance Program Officer  
 Office of Information Management and Analysis  
 1001 I Street, Sacramento, CA 95814
- D. The Discharger shall implement a Quality Assurance-Quality Control Program for any onsite field tests (e.g., turbidity, pH, temperature, dissolved oxygen, conductivity, disinfectant residual) analyzed by a noncertified laboratory. The Discharger shall keep a manual onsite containing the steps followed in this program and must demonstrate sufficient capability to adequately perform these field tests (e.g., qualified and trained employees, properly calibrated and maintained field instruments). The program shall conform to U.S. EPA guidelines or other approved procedures.

**II. MONITORING LOCATIONS**

The Discharger shall establish the following monitoring locations to demonstrate compliance with the effluent limitations, discharge specifications, and other requirements in this Order:

**Table E-1. Monitoring Locations**

Sampling Location Type	Monitoring Location Name	Monitoring Location Description
Influent	INF-001	A point in the treatment plant headworks where all waste tributary to the treatment system is present, preceding any phase of treatment and any plant recirculation or other side streams.
Effluent	EFF-001	A point following all treatment from the treatment plant prior to commingling with other flows to the North Bayside System Unit (NBSU) shared use forcemain. This point may be before disinfection for toxicity tests.

Sampling Location Type	Monitoring Location Name	Monitoring Location Description
Effluent	EFF-001B	During wet weather bypasses of biological treatment, a point in the treatment plant at which all blended (fully-treated and primary-treated) waste is present prior to commingling with other flows to the NBSU shared use forcemain. This location may be the same as Monitoring Location EFF-001.
Effluent	EFF-002	A point following all treatment, including dechlorination at the South San Francisco and San Bruno Water Quality Control Plant, at which all waste tributary to Discharge Point No. 002 is present but prior to discharge.
Biosolids	BIO-001	Biosolids (treated sludge)

### III. INFLUENT MONITORING REQUIREMENTS

The Discharger shall monitor treatment plant influent at Monitoring Location INF-001 as follows:

**Table E-2. Influent Monitoring**

Parameter	Units	Sample Type	Minimum Sampling Frequency
Flow <sup>[1]</sup>	MG/MGD	Continuous	Continuous/D
Biochemical Oxygen Demand (5-day @ 20°C) (BOD <sub>5</sub> ) <sup>[2]</sup>	mg/L	C-24	2/Week
Total Suspended Solids (TSS) <sup>[2]</sup>	mg/L	C-24	2/Week
Cyanide, Total <sup>[3]</sup>	µg/L	Grab	2/Year

Abbreviations:

- MG = million gallons
- MGD = million gallons per day
- mg/L = milligrams per liter
- µg/L = micrograms per liter

Sampling Types and Frequencies:

- C-24 = 24-hour composite sample
- Grab = grab sample
- Continuous = measured continuously
- Continuous/D = measured continuously, and recorded and reported daily
- 2/Week = twice per week
- 2/Year = twice per year

Footnotes:

- <sup>[1]</sup> The following flow information shall be reported in monthly self-monitoring reports:
  - Daily average flow (MGD)
  - Total monthly flow volume (MG)
- <sup>[2]</sup> BOD<sub>5</sub> and TSS samples shall be collected concurrently with effluent samples.
- <sup>[3]</sup> The Discharger may, at its option, analyze for cyanide as weak acid dissociable cyanide using protocols specified in Standard Method Part 4500-CN-I, U.S. EPA Method OI 1677, or an equivalent method in the latest Standard Method edition.

### IV. EFFLUENT MONITORING REQUIREMENTS

A. The Discharger shall monitor treatment plant effluent at Monitoring Locations EFF-001 and EFF-002 as follows:

**Table E-3. Effluent Monitoring—Routine**

Parameter	Units	Sample Type	Minimum Sampling Frequency	Monitoring Location
Flow <sup>[1]</sup>	MG/MGD	Continuous	Continuous/D	EFF-001
BOD <sub>5</sub> <sup>[2]</sup>	mg/L	C-24	2/Week	EFF-001
TSS <sup>[2]</sup>	mg/L	C-24	2/Week	EFF-001
Oil and Grease	mg/L	Grab	1/Quarter	EFF-001
pH <sup>[3]</sup>	s.u.	Grab	2/Week	EFF-001
Chlorine, Total Residual <sup>[4]</sup>	mg/L	Continuous or Grab	1/Hour	EFF-002
Ammonia, Total	mg/L as N	C-24	1/Month	EFF-001
Copper, Total Recoverable	µg/L	C-24	1/Month	EFF-001
Cyanide, Total <sup>[5]</sup>	µg/L	Grab	1/Month	EFF-001 <sup>[6]</sup>
Dioxin-TEQ	µg/L	Grab	2/Year	EFF-001
Fecal Coliform Bacteria	MPN/100 mL <sup>[7]</sup>	Grab	2/Week	EFF-001
Enterococcus Bacteria	MPN/100 mL <sup>[7]</sup>	Grab	4/Year <sup>[8]</sup>	EFF-001
Acute Toxicity <sup>[9]</sup>	% survival	Continuous	1/Month	EFF-001
Chronic Toxicity <sup>[10]</sup>	TU <sub>c</sub>	C-24	2/Year	EFF-001

Abbreviations:

- MG = million gallons
- MGD = million gallons per day
- mg/L = milligrams per liter
- mg/L as N = milligrams per liter as nitrogen
- µg/L = micrograms per liter
- s.u. = standard units
- MPN/100 mL = most probable number per 100 milliliters
- % = percent
- TU<sub>c</sub> = chronic toxicity units

Sampling Types and Frequencies:

- C-24 = 24-hour composite sample
- Grab = grab sample
- Continuous = measured continuously
- Continuous/D = measured continuously, and recorded and reported daily
- 1/Hour = once per hour
- 2/Week = twice per week
- 1/Month = once per month
- 5/Month = five times per month
- 1/Quarter = once per quarter
- 2/Year = twice per year
- 4/Year = four times per year

Footnotes:

- <sup>[1]</sup> The following flow information shall be reported in monthly self-monitoring reports:
  - Daily average flow (MGD)
  - Total monthly flow volume (MG)
- <sup>[2]</sup> BOD<sub>5</sub> and TSS average monthly concentrations and percent removal shall be calculated and reported as follows. For a calendar month in which the Discharger discharges blended effluent, the BOD<sub>5</sub> and TSS average monthly and percent removal calculations shall include flow-weighted results of blended effluent samples collected at Monitoring Location EFF-001B. BOD<sub>5</sub> and TSS samples shall be collected concurrently with influent samples.
- <sup>[3]</sup> If pH is monitored continuously, the minimum and maximum for each day shall be reported in self-monitoring reports.
- <sup>[4]</sup> Effluent residual chlorine concentrations shall be monitored continuously or, at a minimum, every hour. The Discharger shall describe all excursions of the chlorine limit in the transmittal letter of self-monitoring reports as required by Attachment G section V.C.1.a. If monitoring continuously, the Discharger shall report through data upload to CIWQS, from discrete readings of the continuous monitoring every hour on the hour, the maximum for each day and any other discrete hourly reading that exceed the effluent limit, and, for the purpose of mandatory minimum penalties required by Water Code section 13385(i), compliance shall be based only on these discrete readings. The Discharger shall retain continuous monitoring readings for at

least three years. The Regional Water Board reserves the right to use all continuous monitoring data for discretionary enforcement.

The Discharger may elect to use a continuous on-line monitoring system for measuring or determining that residual dechlorinating agent is present. This monitoring system may be used to prove that anomalous residual chlorine exceedances measured by on-line chlorine analyzers are false positives and are not valid total residual chlorine detections because it is chemically improbable to have chlorine present in the presence of sodium bisulfite. If Regional Water Board staff finds convincing evidence that chlorine residual exceedances are false positives, the exceedances are not violations of this Order's total chlorine residual limit.

- [5] The Discharger may, at its option, analyze for cyanide as weak acid dissociable cyanide using protocols specified in Standard Method Part 4500-CN-I, U.S. EPA Method OI 1677, or an equivalent method in the latest Standard Method edition.
- [6] As an alternative, the Discharger may collect cyanide samples at Monitoring Location EFF-002. If so, the Discharger shall indicate that in its self-monitoring reports.
- [7] Results may be reported as Colony Forming Units (CFU)/100 mL if the laboratory method used provides results in CFU/100 mL.
- [8] The four samples shall be collected in different calendar months during the higher recreational water contact season of the year (June to October). If the enterococcus bacteria effluent limitation is exceeded, the Discharger shall conduct 5/Month accelerated sampling for at least three consecutive months. If full compliance is demonstrated after the three-month period, the Discharger may return to the 4/Year sampling frequency.
- [9] Acute toxicity tests shall be performed in accordance with MRP section V.A. Samples may be collected prior to disinfection.
- [10] Chronic toxicity tests shall be performed in accordance with MRP section V.B. Samples may be collected prior to disinfection.

**B. During wet weather bypasses of biological treatment (blending), the Discharger shall monitor treatment plant effluent at Monitoring Locations EFF-001B and EFF-002 as follows:**

**Table E-4. Effluent Monitoring—Blending**

Parameter	Units	Sample Type	Minimum Sampling Frequency	Monitoring Location
Flow <sup>[1]</sup>	MG/MGD	Continuous	Continuous/D	EFF-001B
Volume of Partially-Treated Wastewater Discharged	MG	Calculated	1/Blending Event	EFF-001B
Duration of Blending <sup>[2]</sup>	Hours	Calculated	1/Blending Event	EFF-001B
TSS	mg/L	C-24	1/Day	EFF-001B
Fecal Coliform Bacteria	MPN/100 mL <sup>[3]</sup>	Grab	1/Day	EFF-001B
Enterococcus Bacteria	MPN/100 mL <sup>[3]</sup>	Grab	1/Day	EFF-001B
BOD <sub>5</sub>	mg/L	C-24	1/Year <sup>[4]</sup>	EFF-001B
pH	s.u.	Grab	1/Year <sup>[4]</sup>	EFF-001B
Ammonia, Total	mg/L as N	C-24	1/Year <sup>[4]</sup>	EFF-001B
Copper, Total Recoverable	µg/L	C-24	1/Year <sup>[4]</sup>	EFF-001B
Cyanide, Total <sup>[5]</sup>	µg/L	Grab	1/Year <sup>[4]</sup>	EFF-001B
Chlorine, Total Residual <sup>[6]</sup>	mg/L	Continuous or Grab	1/Hour	EFF-002

Abbreviations:

- MG = million gallons
- MGD = million gallons per day
- mg/L = milligrams per liter
- mg/L as N = milligrams per liter as nitrogen
- µg/L = micrograms per liter
- s.u. = standard units
- MPN/100 mL = most probable number per 100 milliliters

Sampling Type and Frequency:

- C-24 = 24-hour composite sample
- Grab = grab sample
- Continuous = measured continuously
- Continuous/D = measured continuously, and recorded and reported daily
- 1/Blending Event = once per blending event

1/Hour = once per hour  
1/Day = once per day  
1/Year = once per year

Footnote:

- [1] The following flow information shall be reported in monthly self-monitoring reports:
- Daily average flow (MGD)
  - Total monthly flow volume (MG)
- [2] For each blending event, the Discharger shall report the date and time each event starts and ends.
- [3] Results may be reported as Colony Forming Units (CFU)/100 mL if the laboratory method used provides results in CFU/100 mL.
- [4] If a TSS sample collected on the same day exceeds 45 mg/L, the frequency shall be once per day.
- [5] The Discharger may, at its option, analyze for cyanide as weak acid dissociable cyanide using protocols specified in Standard Method Part 4500-CN-I, U.S. EPA Method OI 1677, or an equivalent method in the latest Standard Method edition.
- [6] Effluent residual chlorine concentrations shall be monitored continuously or, at a minimum, every hour. The Discharger shall describe all excursions of the chlorine limit in the transmittal letter of self-monitoring reports as required by Attachment G section V.C.1.a. If monitoring continuously, the Discharger shall report through data upload to CIWQS, from discrete readings of the continuous monitoring every hour on the hour, the maximum for each day and any other discrete hourly reading that exceed the effluent limit, and, for the purpose of mandatory minimum penalties required by Water Code section 13385(i), compliance shall be based only on these discrete readings. The Discharger shall retain continuous monitoring readings for at least three years. The Regional Water Board reserves the right to use all continuous monitoring data for discretionary enforcement.

The Discharger may elect to use a continuous on-line monitoring system for measuring or determining that residual dechlorinating agent is present. This monitoring system may be used to prove that anomalous residual chlorine exceedances measured by on-line chlorine analyzers are false positives and are not valid total residual chlorine detections because it is chemically improbable to have chlorine present in the presence of sodium bisulfite. If Regional Water Board staff finds convincing evidence that chlorine residual exceedances are false positives, the exceedances are not violations of this Order's total chlorine residual limit.

## V. TOXICITY TESTING REQUIREMENTS

### A. Acute Toxicity

1. Compliance with the acute toxicity effluent limitations shall be evaluated at Monitoring Location EFF-001 by measuring survival of test organisms exposed to 96-hour continuous flow-through bioassays.
2. Test organisms shall be fathead minnow (*Pimephales promelas*). Alternatively, the Executive Officer may specify a more sensitive organism or, if testing a particular organism proves unworkable, the most sensitive organism available.
3. All bioassays shall be performed according to the most up-to-date protocols in 40 C.F.R. part 136, currently *Methods for Measuring the Acute Toxicity of Effluents and Receiving Water to Freshwater and Marine Organisms*, 5<sup>th</sup> Edition (EPA-821-R-02-012). If these protocols prove unworkable, the Executive Officer and the Environmental Laboratory Accreditation Program may grant exceptions in writing upon the Discharger's request with justification.
4. If the Discharger demonstrates that specific identifiable substances in the discharge are rapidly rendered harmless upon discharge to the receiving water, compliance with the acute toxicity limit may be determined after test samples are adjusted to remove the influence of those substances. Written acknowledgement that the Executive Officer concurs with the Discharger's demonstration and that the adjustment will not remove the influence of other substances must be obtained prior to any such adjustment. The Discharger may adjust the pH

of acute toxicity samples prior to performing bioassays to minimize ammonia toxicity interference.

5. Samples may be taken from final secondary effluent prior to disinfection. Bioassay water monitoring shall include, on a daily basis, pH, dissolved oxygen, ammonia (if toxicity is observed), temperature, hardness, and alkalinity. These results shall be reported. If final or intermediate results of an acute bioassay test indicate a violation or threatened violation (e.g., the percentage of surviving test organisms is less than 70 percent), the Discharger shall initiate a new test as soon as practical and shall investigate the cause of the mortalities and report its findings in the next self-monitoring report. The Discharger shall repeat the test until a test fish survival rate of 90 percent or greater is observed. If the control fish survival rate is less than 90 percent, the bioassay test shall be restarted with new fish and shall continue as soon as practical until an acceptable test is completed (i.e., control fish survival rate is 90 percent or greater).

## B. Chronic Toxicity

### 1. Monitoring Requirements

- a. **Sampling.** The Discharger shall collect 24-hour composite effluent samples at Monitoring Location EFF-001 for critical life stage toxicity testing as indicated below. Samples may be taken from final secondary effluent prior to disinfection. For toxicity tests requiring renewals, the Discharger shall collect 24-hour composite samples on consecutive or alternating days.
- b. **Test Species.** The test species shall be the water flea (*Ceriodaphnia dubia*) unless a more sensitive species is identified. If using this species proves unworkable, the Executive Officer may specify a different species in writing upon the Discharger's request with justification.

The Discharger shall conduct a screening chronic toxicity test as described in Appendix E-1, or as described in applicable State Water Board plan provisions that become effective after adoption of this Order, following any significant change in the nature of the effluent. If there is no significant change in the nature of the effluent, the Discharger shall conduct a screening test and submit the results with its application for permit reissuance. Upon completion of the chronic toxicity screening, the Discharger shall use the most sensitive species to conduct subsequent monitoring.

- c. **Frequency.** Chronic toxicity monitoring shall be as specified below:
  - i. The Discharger shall monitor routinely twice per year.
  - ii. The Discharger shall accelerate monitoring to monthly after exceeding a single-sample maximum of 10 TU<sub>c</sub>. Based on the TU<sub>c</sub> results, the Executive Officer may specify a different frequency for accelerated monitoring to ensure that accelerated monitoring provides useful information.
  - iii. The Discharger shall return to routine monitoring if accelerated monitoring does not exceed the trigger in ii, above.



- iv. If accelerated monitoring confirms consistent toxicity in excess of the trigger in ii, above, the Discharger shall continue accelerated monitoring and initiate toxicity reduction evaluation (TRE) procedures in accordance with section V.B.3, below.
  - v. The Discharger shall return to routine monitoring after implementing appropriate elements of the TRE, and either the toxicity drops below the trigger in ii, above, or, based on the TRE results, the Executive Officer determines that accelerated monitoring would no longer provide useful information.
  - vi. Monitoring conducted pursuant to a TRE shall satisfy the requirements for routine and accelerated monitoring while the TRE is underway.
- d. Methodology.** Sample collection, handling, and preservation shall be in accordance with U.S. EPA protocols. Bioassays shall be conducted in compliance with the most recently promulgated test methods, as shown in Appendix E-2. These are *Short Term Methods for Estimating the Chronic Toxicity of Effluents and Receiving Waters to West Coast Marine and Estuarine Organisms*, currently first edition (EPA/600/R-95-136), *Short-Term Methods for Estimating the Chronic Toxicity of Effluents and Receiving Waters to Marine and Estuarine Organisms*, currently third edition (EPA-821-R-02-014) and *Short-Term Methods for Estimating the Chronic Toxicity of Effluents and Receiving Waters to Freshwater Organisms*, currently fourth edition (EPA-821-R2-02-013). If these protocols prove unworkable, the Executive Officer and the Environmental Laboratory Accreditation Program may grant exceptions in writing upon the Discharger's request with justification.

If the Discharger demonstrates that specific identifiable substances in the discharge are rapidly rendered harmless upon discharge to the receiving water, compliance with the chronic toxicity limit may be determined after test samples are adjusted to remove the influence of those substances. The adjustment shall not remove the influence of other substances. Written acknowledgement that the Executive Officer concurs with the Discharger's demonstration must be obtained prior to any such adjustment.

- e. **Dilution Series.** The Discharger shall conduct tests at 40%, 20%, 10%, 5%, and 2.5%. The "%" represents percent effluent as discharged. Test sample pH may be controlled to the level of the effluent sample as received prior to being salted up.

## 2. Reporting Requirements

- a. The Discharger shall provide toxicity test results with self-monitoring reports and shall include the following, at a minimum, for each test:
  - i. Sample data
  - ii. Test initiation date
  - iii. Test species
  - iv. End point values for each dilution (e.g., number of young, growth rate, percent survival)

- v. No Observable Effect Level (NOEL) values in percent effluent. The NOEL shall equal the IC<sub>25</sub> or EC<sub>25</sub> (see MRP Appendix E-1). If the IC<sub>25</sub> or EC<sub>25</sub> cannot be statistically determined, the NOEL shall equal the No Observable Effect Concentration (NOEC) derived using hypothesis testing. The NOEC is the maximum percent effluent concentration that causes no observable effect on test organisms based on a critical life stage toxicity test.
- vi. IC<sub>15</sub>, IC<sub>25</sub>, IC<sub>40</sub>, and IC<sub>50</sub> values (or EC<sub>15</sub>, EC<sub>25</sub>, EC<sub>40</sub>, and EC<sub>50</sub>) as percent effluent
- vii. TU<sub>c</sub> values (100/NOEL and upper and lower confidence intervals)
- viii. Mean percent mortality ( $\pm$ s.d.) after 96 hours in 100% effluent (if applicable)
- ix. IC<sub>50</sub> or EC<sub>50</sub> values for reference toxicant tests
- x. Available water quality measurements for each test (e.g., pH, dissolved oxygen, temperature, conductivity, hardness, salinity, ammonia)

### 3. Toxicity Reduction Evaluation (TRE)

- a. The Discharger shall prepare a generic TRE work plan within 90 days of the effective date of this Order to be ready to respond to toxicity events. The Discharger shall review and update the work plan as necessary so that it remains current and applicable to the discharge and discharge facilities.
- b. Within 30 days of exceeding the chronic toxicity trigger, the Discharger shall submit a TRE work plan, which shall be the generic work plan revised as appropriate for this toxicity event after consideration of available discharge data.
- c. Within 30 days of completing an accelerated monitoring test observed to exceed the trigger, the Discharger shall initiate a TRE in accordance with a TRE work plan that incorporates any and all Executive Officer comments.
- d. The TRE shall be specific to the discharge and be in accordance with current technical guidance and reference materials, including U.S. EPA guidance materials. The Discharger shall conduct the TRE as a tiered evaluation as summarized below:
  - i. Tier 1 shall consist of basic data collection (routine and accelerated monitoring).
  - ii. Tier 2 shall consist of evaluation of treatment process, including operational practices and in-plant process chemicals.
  - iii. Tier 3 shall consist of a toxicity identification evaluation (TIE).
  - iv. Tier 4 shall consist of a toxicity source evaluation.
  - v. Tier 5 shall consist of a toxicity control evaluation, including options for modifications of in-plant treatment processes.
  - vi. Tier 6 shall consist of implementation of selected toxicity control measures, and follow-up monitoring and confirmation of implementation success.

- e. The Discharger may end the TRE at any stage if monitoring finds there is no longer consistent toxicity (i.e., compliance with the trigger in section V.B.1.e).
- f. The objective of the TIE shall be to identify the substance or combination of substances causing the observed toxicity. The Discharger shall employ all reasonable efforts using currently available TIE methodologies.
- g. As toxic substances are identified or characterized, the Discharger shall continue the TRE by determining the sources and evaluating alternative strategies for reducing or eliminating the toxic substances from the discharge. The Discharger shall take all reasonable steps to reduce toxicity to levels below the chronic toxicity trigger.
- h. Many recommended TRE elements parallel required or recommended efforts related to source control, pollution prevention, and stormwater control programs. TRE efforts should be coordinated with such efforts. To prevent duplication of efforts, evidence of complying with requirements or recommended efforts of such programs may be acceptable to demonstrate compliance with TRE requirements.

**VI. RECEIVING WATER MONITORING REQUIREMENTS**

The Discharger shall continue to participate in the Regional Monitoring Program, which collects data on pollutants and toxicity in San Francisco Bay water, sediment, and biota.

**VII. PRETREATMENT AND BIOSOLIDS MONITORING REQUIREMENTS**

The Discharger shall comply with the following pretreatment monitoring requirements for influent at Monitoring Location INF-001, effluent at Monitoring Location EFF-001, and biosolids at Monitoring Location BIO-001. The Discharger shall report summaries of analytical results in annual and semi-annual pretreatment reports in accordance with Attachment H. If instructed to do so, the Discharger shall report biosolids analytical results with its electronic self-monitoring reports by manual entry, by EDF/CDF, or as an attached file.

**Table E-5. Pretreatment and Biosolids Monitoring**

Constituents	Sampling Frequency			Sample Type	
	Influent INF-001 <sup>[1]</sup>	Effluent EFF-001 <sup>[1]</sup>	Biosolids BIO-001	Influent and Effluent	Biosolids <sup>[2]</sup>
VOC <sup>[3]</sup>	Once	Once	Once	Grab	Grab
BNA <sup>[4]</sup>	Once	Once	Once	Grab	Grab
Metals and Other Elements <sup>[5]</sup>	1/Year	1/Year	1/Year	C-24 <sup>[6]</sup>	Grab
Hexavalent Chromium <sup>[7]</sup>	1/Year	1/Year	1/Year	Grab	Grab
Mercury <sup>[8]</sup>	1/Year	1/Year	1/Year	Grab or C-24 <sup>[6]</sup>	Grab
Copper	1/Year	1/Month	1/Year	C-24 <sup>[6]</sup>	Grab
Cyanide, Total <sup>[9]</sup>	2/Year	1/Month	1/Year	Grab	Grab

Sampling Types and Frequencies:

- C-24 = 24-hour composite sample
- Grab = grab sample
- 1/Month = once per month
- 1/Year = once per year
- 2/Year = twice per year
- Once = once per permit term

Footnotes:

- [1] Influent and effluent monitoring conducted in accordance with MRP Tables E-2 and E-3 may be used to satisfy these pretreatment monitoring requirements.
- [2] The biosolids sample shall be a composite of the biosolids to be disposed. Biosolids collection and monitoring shall comply with the requirements specified in Attachment H, Appendix H-4.
- [3] VOC: volatile organic compounds.
- [4] BNA: base/neutrals and acid extractable organic compounds.
- [5] Metals and other elements are arsenic, cadmium, copper, lead, nickel, selenium, silver, and zinc.
- [6] If an automatic compositor is used, the Discharger shall obtain 24-hour composite samples through flow-proportioned composite sampling. Alternatively, 24-hour composite samples may consist of discrete grab samples combined (volumetrically flow-weighted) prior to analysis or mathematically flow-weighted.
- [7] The Discharger may choose to monitor and report total chromium instead of hexavalent chromium. Samples collected for total chromium measurements may be 24-hour composites.
- [8] The Discharger shall use the ultra-clean sampling (U.S. EPA Method 1669) and ultra-clean analytical methods (U.S. EPA Method 1631) for mercury monitoring, except when levels are expected to exceed 10 µg/L, in which case use of ultra-clean sampling and analysis shall be optional.
- [9] The Discharger may, at its option, analyze for cyanide as weak acid dissociable cyanide using protocols specified in Standard Method Part 4500-CN-I, U.S. EPA Method OI 1677, or an equivalent method in the latest Standard Method edition.

## VIII. REPORTING REQUIREMENTS

### A. General Monitoring and Reporting Requirements

The Discharger shall comply with all Standard Provisions (Attachments D and G) related to monitoring, reporting, and recordkeeping.

### B. Self-Monitoring Reports (SMRs)

1. **SMR Format.** The Discharger shall electronically submit SMRs using the State Water Board's California Integrated Water Quality System (CIWQS) website at [http://www.waterboards.ca.gov/water\\_issues/programs/ciwqs](http://www.waterboards.ca.gov/water_issues/programs/ciwqs). The CIWQS website will provide additional information for SMR submittal in the event of a planned service interruption for electronic submittal.
2. **SMR Due Dates and Contents.** The Discharger shall submit SMRs by the due dates, and with the contents, specified below:
  - a. **Monthly SMRs.** Monthly SMRs shall be due 30 days after the end of each calendar month, covering that calendar month. The monthly SMR shall contain the applicable items described in sections V.B and V.C of both Attachments D and G of this Order. See Provision VI.C.2 (Effluent Characterization Study and Report) of this Order for information that must also be reported with monthly SMRs.

Monthly SMRs shall include all new monitoring results obtained since the last SMR was submitted. If the Discharger monitors any pollutant more frequently than required by this Order, the Discharger shall include the results of such monitoring in the calculations and reporting for the SMR.

- b. **Annual SMR.** Annual SMRs shall be due February 1 each year, covering the previous calendar year. The annual SMR shall contain the items described in section V.C.1.f of Attachment G. See also Provision VI.C.2 (Effluent Characterization Study and Report)

and Provision VI.C.5.a (Specific Tasks to Reduce Blending) of the Order for requirements to submit reports with the annual SMR.

**3. Specifications for Submitting SMRs to CIWQS.** The Discharger shall submit analytical results and other information using one of the following methods:

**Table E-6. CIWQS Reporting**

Parameter	Method of Reporting	
	EDF/CDF data upload or manual entry	Attached File
All parameters identified in influent, effluent, and receiving water monitoring tables (except Dissolved Oxygen and Temperature)	Required for all results	
Dissolved Oxygen Temperature	Required for monthly maximum and minimum results only <sup>[1]</sup>	Discharger may use this method for all results or keep records
Antimony Arsenic Beryllium Cadmium Chromium Copper Cyanide Lead Mercury Nickel Selenium	Silver Thallium Zinc Dioxins & Furans (by U.S. EPA Method 1613) Other Pollutants (by U.S. EPA Methods 601, 602, 608, 610, 614, 624, and 625)	Required for all results <sup>[2]</sup>
Volume and Duration of Blended Discharge <sup>[3]</sup>	Required for all blended effluent discharges	
Analytical Method	Not required (Discharger may select "data unavailable") <sup>[1]</sup>	
Collection Time Analysis Time	Not required (Discharger may select "0:00") <sup>[1]</sup>	

Footnotes:

- <sup>[1]</sup> The Discharger shall continue to monitor at the minimum frequency specified in this MRP, keep records of the measurements, and make the records available upon request.
- <sup>[2]</sup> These parameters require EDF/CDF data upload or manual entry regardless of whether monitoring is required by this MRP or other provisions of this Order (except for biosolids, sludge, or ash provisions).
- <sup>[3]</sup> The requirement for volume and duration of blended discharge applies only if this Order authorizes the Discharger to discharge blended effluent.

The Discharger shall arrange all reported data in a tabular format and summarize data to clearly illustrate whether the Facility is operating in compliance with effluent limitations. The Discharger is not required to duplicate the submittal of data entered in a tabular format within CIWQS. When electronic submittal of data is required and CIWQS does not provide for entry into a tabular format, the Discharger shall electronically submit the data in a tabular format as an attachment.

**4. Monitoring Periods.** Monitoring periods for all required monitoring shall be as set forth below unless otherwise specified:

**Table E-7. Monitoring Periods**

Sampling Frequency	Monitoring Period Begins On...	Monitoring Period
Continuous Continuous/D	Order effective date	All times
1/Hour	Order effective date	Every hour on the hour
1/Day	Order effective date	Any 24-hour period that reasonably represents a calendar day for sampling purposes (e.g., beginning at midnight and continuing through 11:59 p.m.)
2/Week	First Sunday following or on Order effective date	Sunday through Saturday
1/Month 5/Month	First day of calendar month following or on Order effective date	First day of calendar month through last day of calendar month
1/Quarter	Closest January 1, April 1, July 1, or October 1 following or on Order effective date <sup>[1]</sup>	January 1 through March 31 April 1 through June 30 July 1 through September 30 October 1 through December 31
1/Year	Closest January 1 before or after Order effective date <sup>[1]</sup>	January 1 through December 31
2/Year	Closest January 1 or July 1 before or after Order effective date <sup>[1]</sup>	January 1 through June 30 July 1 through December 31
4/Year	Closest June 1, July 1, August 1, September 1, or October 1 following Order effective date	June 1 through October 31
Once	Order effective date	Once during the permit term within 12 months prior to applying for permit reissuance
1/Blending Event	Order effective date	Blending event duration

Footnote:

<sup>[1]</sup> Monitoring performed during the previous order term may be used to satisfy monitoring required by this Order.

**5. RL and MDL Reporting.** The Discharger shall report with each sample result the Reporting Level (RL) and Method Detection Limit (MDL) as determined by the procedure in 40 C.F.R. part 136. The Discharger shall report the results of analytical determinations for the presence of chemical constituents in a sample using the following reporting protocols:

- a. Sample results greater than or equal to the RL shall be reported as measured by the laboratory (i.e., the measured chemical concentration in the sample).
- b. Sample results less than the RL, but greater than or equal to the laboratory’s MDL, shall be reported as “Detected, but Not Quantified,” or DNQ. The estimated chemical concentration of the sample shall also be reported.

For purposes of data collection, the laboratory shall write the estimated chemical concentration next to DNQ. The laboratory may, if such information is available, include numerical estimates of the data quality for the reported result. Numerical estimates of data quality may be percent accuracy (+/- a percentage of the reported value), numerical ranges (low to high), or any other means the laboratory considers appropriate.

- c. Sample results less than the laboratory's MDL shall be reported as "Not Detected", or ND.
  - d. The Discharger shall instruct laboratories to establish calibration standards so that the minimum level (ML) value (or its equivalent if there is differential treatment of samples relative to calibration standards) is the lowest calibration standard. At no time is the Discharger to use analytical data derived from extrapolation beyond the lowest point of the calibration curve.
- 6. Compliance Determination.** Compliance with effluent limitations for priority pollutants shall be determined using sample reporting protocols defined above and in the Fact Sheet and Attachments A, D, and G. For purposes of reporting and administrative enforcement by the Regional Water Board and State Water Board, the Discharger shall be deemed out of compliance with effluent limitations if the concentration of the priority pollutant in the monitoring sample is greater than the effluent limitation and greater than or equal to the RL.

### C. Discharge Monitoring Reports (DMRs)

DMRs are U.S. EPA reporting requirements. The Discharger shall electronically certify and submit DMRs together with SMRs using the Electronic Self-Monitoring Reports module eSMR 2.5 or the latest upgraded version. Electronic DMR submittal shall be in addition to electronic SMR submittal. Information about electronic DMR submittal is available at the DMR website at [http://www.waterboards.ca.gov/water\\_issues/programs/discharge\\_monitoring](http://www.waterboards.ca.gov/water_issues/programs/discharge_monitoring).

## APPENDIX E-1 CHRONIC TOXICITY DEFINITION OF TERMS AND SCREENING PHASE REQUIREMENTS

### I. Definition of Terms

- A. No observed effect level (NOEL) for compliance determination is equal to IC<sub>25</sub> or EC<sub>25</sub>. If the IC<sub>25</sub> or EC<sub>25</sub> cannot be statistically determined, the NOEL shall be equal to the NOEC derived using hypothesis testing.
- B. Effective concentration (EC) is a point estimate of the toxicant concentration that would cause an adverse effect on a quantal, “all or nothing,” response (such as death, immobilization, or serious incapacitation) in a given percent of the test organisms. If the effect is death or immobility, the term lethal concentration (LC) may be used. EC values may be calculated using point estimation techniques such as probit, logit, and Spearman-Kärber. EC<sub>25</sub> is the concentration of toxicant (in percent effluent) that causes a response in 25 percent of the test organisms.
- C. Inhibition concentration (IC) is a point estimate of the toxicant concentration that would cause a given percent reduction in a nonlethal, nonquantal biological measurement, such as growth. For example, an IC<sub>25</sub> is the estimated concentration of toxicant that would cause a 25 percent reduction in average young per female or growth. IC values may be calculated using a linear interpolation method such as USEPA's Bootstrap Procedure.
- D. No observed effect concentration (NOEC) is the highest tested concentration of an effluent or a toxicant at which no adverse effects are observed on the aquatic test organisms at a specific time of observation. It is determined using hypothesis testing.

### II. Chronic Toxicity Screening Phase Requirements

- A. The Discharger shall perform screening phase monitoring:
  - 1. Subsequent to any significant change in the nature of the effluent discharged through changes in sources or treatment, except those changes resulting from reductions in pollutant concentrations attributable to source control efforts, or
  - 2. Prior to permit reissuance. Screening phase monitoring data shall be included in the NPDES permit application for reissuance. The information shall be as recent as possible, but may be based on screening phase monitoring conducted within 5 years before the permit expiration date.
- B. Design of screening phase shall, at a minimum, consist of following elements:
  - 1. Use of test species specified in Appendix E-2, attached, and use of the protocols referenced in those tables, or as approved by the Executive Officer.
  - 2. Two stages:
    - a. Stage 1 shall consist of a minimum of one battery of tests conducted concurrently. Selection of the type of test species and minimum number of tests shall be based on Appendix E-2 (attached).



- b. Stage 2 shall consist of a minimum of two test batteries conducted at a monthly frequency using the three most sensitive species based on the Stage 1 test results and as approved by the Executive Officer.
  3. Appropriate controls.
  4. Concurrent reference toxicant tests.
  5. Dilution series 100%, 40%, 20%, 10%, 5%, 2.5 %, where “%” is percent effluent as discharged, or as otherwise approved the Executive Officer if different dilution ratios are needed to reflect discharge conditions.
- C. The Discharger shall submit a screening phase proposal. The proposal shall address each of the elements listed above. If within 30 days, the Executive Officer does not comment, the Discharger shall commence with screening phase monitoring.

**APPENDIX E-2  
 SUMMARY OF TOXICITY TEST SPECIES REQUIREMENTS**

**Table AE-1. Critical Life Stage Toxicity Tests for Estuarine Waters**

Species	(Scientific Name)	Effect	Test Duration	Reference
Alga	<i>(Skeletonema costatum)</i> <i>(Thalassiosira pseudonana)</i>	Growth rate	4 days	1
Red alga	<i>(Champia parvula)</i>	Number of cytocarps	7 – 9 days	3
Giant kelp	<i>(Macrocystis pyrifera)</i>	Percent germination; germ tube length	48 hours	2
Abalone	<i>(Haliotis rufescens)</i>	Abnormal shell development	48 hours	2
Oyster Mussel	<i>(Crassostrea gigas)</i> <i>(Mytilus edulis)</i>	Abnormal shell development; percent survival	48 hours	2
Echinoderms – Urchins Sand dollar	<i>(Strongylocentrotus purpuratus,</i> <i>S. franciscanus)</i> <i>(Dendraster excentricus)</i>	Percent fertilization or larval development	1 hour or 72 hours	2
Shrimp	<i>(Mysidopsis bahia)</i>	Percent survival; growth	7 days	3
Shrimp	<i>(Holmesimysis costata)</i>	Percent survival; growth	7 days	2
Topsmelt	<i>(Atherinops affinis)</i>	Percent survival; growth	7 days	2
Silverside	<i>(Menidia beryllina)</i>	Larval growth rate; percent survival	7 days	3

**Toxicity Test References:**

1. American Society for Testing Materials (ASTM). 1990. Standard Guide for Conducting Static 96-Hour Toxicity Tests with Microalgae. Procedure E 1218-90. ASTM, Philadelphia, PA.
2. Short-term Methods for Estimating the Chronic Toxicity of Effluent and Receiving Waters to West Coast Marine and Estuarine Organisms. EPA/600/R-95/136. August 1995.
3. Short-term Methods for Estimating the Chronic Toxicity of Effluent and Receiving Waters to Marine and Estuarine Organisms. EPA/821/R-02/014. October 2002.

**Table AE-2. Critical Life Stage Toxicity Tests for Fresh Waters**

Species	(Scientific Name)	Effect	Test Duration	Reference
Fathead minnow	<i>(Pimephales promelas)</i>	Survival; growth rate	7 days	4
Water flea	<i>(Ceriodaphnia dubia)</i>	Survival; number of young	7 days	4
Alga	<i>(Selenastrum capricornutum)</i>	Cell division rate	4 days	4

**Toxicity Test Reference:**

- Short-term Methods for Estimating the Chronic Toxicity of Effluents and Receiving Waters to Freshwater Organisms, fourth Edition Chronic manual (EPA-821-R-02-013, October 2002).

**Table AE-3. Toxicity Test Requirements for Stage One Screening Phase**

Requirements	Receiving Water Characteristics		
	Discharge to coast	Discharge to San Francisco Bay <sup>[1]</sup>	
	Ocean	Marine/Estuarine	Freshwater
Taxonomic diversity	1 plant 1 invertebrate 1 fish	1 plant 1 invertebrate 1 fish	1 plant 1 invertebrate 1 fish
Number of tests of each salinity type: Freshwater <sup>[2]</sup>	0	1 or 2	3
Marine/Estuarine	4	3 or 4	0
Total number of tests	4	5	3

**Footnotes:**

- Marine refers to receiving water salinities greater than 10 parts per thousand (ppt) at least 95 percent of the time during a normal water year.
  - Freshwater refers to receiving water with salinities less than 1 ppt at least 95 percent of the time during a normal water year.
  - Estuarine refers to receiving water salinities that fall between those of marine and freshwater, as described above.
- The freshwater species may be substituted with marine species if:
  - The salinity of the effluent is above 1 ppt greater than 95 percent of the time, or
  - The ionic strength (TDS or conductivity) of the effluent at the test concentration used to determine compliance is documented to be toxic to the test species.

**ATTACHMENT F - FACT SHEET**

**Contents**

I. Permit Information..... F-2

II. Facility Description..... F-3

    A. Wastewater and Biosolids Treatment..... F-3

    B. Discharge Point and Receiving Waters ..... F-5

    C. Previous Requirements and Monitoring Data ..... F-5

    D. Compliance Summary ..... F-6

    E. Planned Changes ..... F-8

III. Applicable Plans, Policies, and Regulations..... F-8

IV. Rationale For Effluent Limitations and Discharge Specifications ..... F-10

    A. Discharge Prohibitions ..... F-11

    B. Technology-Based Effluent Limitations ..... F-12

        1. Scope and Authority ..... F-12

        2. Effluent Limitations ..... F-13

    C. Water Quality-Based Effluent Limitations (WQBELs) ..... F-13

        1. Scope and Authority ..... F-13

        2. Beneficial Uses and Water Quality Criteria and Objectives ..... F-14

        3. Need for Water Quality-Based Effluent Limitations (Reasonable Potential Analysis) .. F-17

        4. Water Quality-Based Effluent Limitations (WQBELs) ..... F-22

    D. Discharge Requirement Considerations ..... F-27

V. Rationale for Receiving Water Limitations ..... F-28

VI. Rationale for Provisions..... F-28

    A. Standard Provisions..... F-28

    B. Monitoring and Reporting ..... F-28

    C. Special Provisions ..... F-28

        1. Reopener Provisions..... F-28

        2. Effluent Characterization Study and Report ..... F-28

        3. Pollutant Minimization Program..... F-29

        4. Special Provisions for Publicly-Owned Treatment Works (POTWs)..... F-29

        5. Other Special Provisions ..... F-29

VII. Rationale for Monitoring and Reporting Program (MRP) ..... F-31

VIII. Public Participation ..... F-33

**Tables**

Table F-1. Facility Information..... F-2

Table F-2. Previous Effluent Limitations and Monitoring Data..... F-5

Table F-3. Collection System and SSO Rates (SSO per 100 miles)..... F-7

Table F-4. Beneficial Uses..... F-9

Table F-5. Secondary Treatment Standards..... F-12

Table F-6. Site-Specific Translators ..... F-17

Table F-7. Reasonable Potential Analysis ..... F-18

Table F-8. WQBEL Calculations..... F-25

Table F-9. Monitoring Requirements Summary ..... F-32

## ATTACHMENT F – FACT SHEET

This Fact Sheet includes the legal requirements and technical rationale that serve as the basis for the requirements of this Order. As described in section II.B of the Order, the Regional Water Board incorporates this Fact Sheet as findings supporting the issuance of the Order.

### I. PERMIT INFORMATION

The following table summarizes administrative information related to the facility:

**Table F-1. Facility Information**

<b>WDID</b>	2 417005001
<b>CIWQS Place ID</b>	210839
<b>Discharger</b>	City of Burlingame and North Bayside System Unit (NBSU)
<b>Name of Facility</b>	City of Burlingame Wastewater Treatment Facility and wastewater collection system
<b>Facility Address</b>	1103 Airport Boulevard, Burlingame, CA 94010 San Mateo County
<b>Facility Contact, Title, Phone</b>	Michael Thompson, Assistant Plant Manager, (650) 342-3727
<b>Authorized Person to Sign and Submit Reports</b>	Same as above
<b>Mailing Address</b>	510 Primrose Road, Burlingame, CA 94010
<b>Billing Address</b>	Same as Mailing Address
<b>Type of Facility</b>	Publicly-Owned Treatment Works (POTW)
<b>Major or Minor Facility</b>	Major
<b>Threat to Water Quality</b>	2
<b>Complexity</b>	A
<b>Pretreatment Program</b>	Yes
<b>Reclamation Requirements</b>	None
<b>Mercury and PCBs Requirements</b>	NPDES Permit No. CA0038849
<b>Nutrients Requirements</b>	NPDES Permit No. CA0038873
<b>Facility Permitted Flow</b>	5.5 million gallons per day (MGD) (average dry weather flow)
<b>Facility Design Flow</b>	5.5 MGD (average dry weather flow) 16 MGD (peak wet weather flow)
<b>Watershed</b>	San Francisco Bay
<b>Receiving Water</b>	Lower San Francisco Bay
<b>Receiving Water Type</b>	Marine

- A.** The City of Burlingame and the North Bayside System Unit (NBSU) (together, the Discharger) discharge treated wastewater into the deepwater channel of Lower San Francisco Bay. The City of Burlingame owns the Wastewater Treatment Facility (Plant), a Publicly-Owned Treatment Works, and the portion of the wastewater collection system and effluent forcemain located within its city limits. The Plant, currently operated by Veolia Water West Operating Services, Inc., under contract with the City, provides secondary treatment of wastewater and discharges the effluent to the NBSU forcemain. The NBSU is a joint powers authority that includes the cities of Burlingame, Millbrae, South San Francisco and San Bruno, and the San Francisco International Airport. The NBSU owns and operates the effluent forcemain outside of Burlingame’s city limits, the combined effluent pumping station, effluent dechlorination facilities, and the deepwater outfall. For the purposes of this Order, the Plant, the City of Burlingame’s collection system and effluent forcemain, and the

NBSU forcemain, combined effluent pumping station, dechlorination facilities, and deepwater outfall are collectively referred to as the “Facility.”

For the purposes of this Order, references to the “discharger” or “permittee” in applicable federal and State laws, regulations, plans, or policies are held to be equivalent to references to the Discharger herein.

- B.** The Discharger is regulated pursuant to National Pollutant Discharge Elimination System (NPDES) Permit No. CA0037788. The Discharger was previously subject to Order No. R2-2013-0015 (previous order). The Discharger filed a Report of Waste Discharge and submitted an application for reissuance of its Waste Discharge Requirements (WDRs) and NPDES permit on December 29, 2017.

The Discharger is authorized to discharge subject to the WDRs in this Order at the discharge location described in Table 2 of this Order. Regulations at 40 C.F.R. section 122.46 limit the duration of NPDES permits to a fixed term not to exceed five years. Accordingly, Table 3 of this Order limits the effective period for the discharge authorization. Pursuant to California Code of Regulations, title 23, section 2235.4, the terms and conditions of an expired permit are automatically continued pending reissuance of the permit if the Discharger complies with all requirements for continuation of expired permits. (40 C.F.R § 122.6[d].)

- C.** Order No. R2-2016-0008 amended the previous order to provide for an alternate monitoring program and remains in effect with this Order. The discharge is also regulated under NPDES Permit Nos. CA0038849 and CA0038873, which establish requirements on mercury and polychlorinated biphenyls (PCBs) and nutrients from wastewater discharges to San Francisco Bay. This Order does not affect those permits.
- D.** When applicable, State law requires dischargers to file a petition with the State Water Resources Control Board (State Water Board), Division of Water Rights, and receive approval for any change in the point of discharge, place of use, or purpose of use of treated wastewater that decreases the flow in any portion of a watercourse. The State Water Board retains separate jurisdictional authority to enforce such requirements under Water Code section 1211. This is not an NPDES permit requirement.

## II. FACILITY DESCRIPTION

### A. Wastewater and Biosolids Treatment

- 1. Location and Service Area.** The Plant is located at 1103 Airport Boulevard in the City of Burlingame. It provides secondary treatment of domestic and commercial wastewater for the City of Burlingame, Town of Hillsborough, and the Burlingame Hills Sewer Maintenance District. The service area population is approximately 37,000 (30,300 in the City of Burlingame; 5,300 in the Town of Hillsborough; and 1,250 in the Burlingame Hills area). No significant industrial users are located within the service area. Attachment B shows a map of the area around the Plant.

During the dry season, more than 80 percent of the influent comes from the City of Burlingame (as estimated based on population served and average dry weather flow of 3 MGD). The Town of Hillsborough, on average, contributes approximately 0.4 MGD, representing about 14 percent of the average dry weather flow. The Burlingame Hills area

contributes approximately 0.09 MGD, representing about 3 percent of the average dry weather flow.

2. **Collection System.** The City of Burlingame owns the wastewater collection system located within its city limits. It consists of approximately 8,500 connections and 118 miles of pipeline (81 miles of sanitary sewer lines, 6 miles of forcemain, and 31 miles of lower laterals), with 7 pump stations. The Plant also receives wastewater from two satellite collection system agencies—the Town of Hillsborough and the Burlingame Hills Sewer Maintenance District. The Town of Hillsborough has approximately 1,800 connections and 43 miles of pipeline within the Burlingame Sewer Basin service area (its remaining connections and pipeline are in the San Mateo Sewer Basin). The Burlingame Hills Sewer Maintenance District has approximately 440 connections and 6 miles of pipeline (all within the Burlingame Sewer Basin service area). The City of Burlingame has agreements with the satellite collection system agencies requiring the satellite collection system agencies to properly maintain those collection systems as a condition of using the Plant.
3. **Wastewater Treatment.** The wastewater treatment process consists of screening (two bar screens), grit removal (vortex-type grit remover), primary sedimentation (two primary clarifiers), biological treatment (four aeration basins), secondary clarification (four secondary clarifiers), and chlorine disinfection using sodium hypochlorite. Treated wastewater is discharged to the NBSU forcemain, which transports treated wastewater to the South San Francisco and San Bruno Water Quality Control Plant for dechlorination using sodium bisulfite prior to discharge to Lower San Francisco Bay from Discharge Point No. 002. These steps are shown in the process flow diagram in Attachment C. The treatment plant has an average daily treatment capacity of up to 5.5 million gallons per day (MGD) and a peak wet weather capacity of 16 MGD. From July 2013 through November 2017, the plant treated a daily average of 3 MGD.

During wet weather, primary effluent flows in excess of 13.5 MGD (maximum biological treatment capacity) are directed to onsite temporary storage units, which include an offline primary clarifier (0.4 million gallons [MG]), a stormwater retention basin (1.6 MG), and an offline aeration basin (0.3 MG). When the storage units reach their maximum capacity, primary effluent flows in excess of 13.5 MGD bypass biological treatment and are blended with effluent receiving biological treatment. The blended effluent is disinfected and discharged to the NBSU forcemain. Such bypasses may be necessary at times to prevent washout of microbial populations in the biological treatment units. Prior to the installation of the stormwater retention basin in September 2012, the Discharger blended nine times from 2005 through 2012. The Discharger has not blended since the installation of the stormwater retention basin. Bypasses of biological treatment are subject to Discharge Prohibition III.C and Attachment D section I.G (see Fact Sheet § IV.A.3).

4. **Sludge and Biosolids Management.** The Discharger thickens primary sludge with a gravity thickener and waste activated sludge with a gravity belt thickener. All thickened sludge is then treated by anaerobic digestion and dewatered by a belt filter press or centrifuge. Dewatered sludge is trucked to either composting sites, land application sites, or landfills for disposal.
5. **Stormwater Management.** Most stormwater captured within the Plant's storm drain system is directed to the headworks. For the storm drains that do not drain to the headworks, the

Discharger is covered under the State Water Board’s statewide NPDES permit for stormwater discharges associated with industrial activities (NPDES General Permit CAS000001).

**B. Discharge Point and Receiving Waters**

Treated effluent flows through a 60-inch NBSU forcemain and discharges into Lower San Francisco Bay at Discharge Point No. 002 via a 654-foot diffuser composed of 102 three-inch ports spaced 7 feet apart. The location of the outfall is northeast of Point San Bruno, approximately 5,300 feet offshore at depth 20 feet below mean lower low water. The NBSU operates and maintains the outfall and regular inspections occur on a 10-year schedule. An inspection most recently occurred in May 2015. Divers found all diffuser ports to be performing per specification, but noted that the fasteners securing the end gate needed to be replaced. Repairs were completed in July 2015.

When the effluent flow rate reaches 16 MGD (the engineered contractual limit for the NBSU pipeline), fully treated (primary and biologically treated), disinfected, and dechlorinated effluent is discharged through an emergency shallow water outfall. This emergency outfall is a gated weir just off the final clarifier and is located approximately 6.2 miles southeast of Discharge Point No. 002. It is less than 0.1 mile from the point where treated effluent enters the NBSU forcemain. These bypasses of the deepwater outfall are subject to Discharge Prohibition III.C and Attachment D section I.G of this Order. The Discharger used the emergency shallow water outfall once during the previous order term when it discharged 2.7 MG of fully-treated effluent over a duration of 5 hours during heavy rains in January 2017.

**C. Previous Requirements and Monitoring Data**

The table below presents the previous order’s effluent limitations and representative monitoring data from the previous order term:

**Table F-2. Previous Effluent Limitations and Monitoring Data**

Parameter	Units	Effluent Limitations			Monitoring Data (7/2013 – 11/2017)
		Monthly Average	Weekly Average	Daily Maximum	Highest Daily Discharge
Biochemical Oxygen Demand (5-day @ 20°C) (BOD <sub>5</sub> )	mg/L	30	45	---	45
Total Suspended Solids (TSS)	mg/L	30	45	---	31
BOD <sub>5</sub> percent removal	%	85 (minimum)	---	---	90 <sup>[1]</sup>
TSS percent removal	%	85 (minimum)	---	---	91 <sup>[1]</sup>
Oil and Grease	mg/L	10	---	20	11
pH	s.u.	6.0 – 9.0			6.0 – 8.3 <sup>[2]</sup>
Chlorine, Total Residual	mg/L	---	---	0.0	0
Bis(2-ethylhexyl)phthalate	µg/L	59	---	120	2.4 DNQ
Copper, Total Recoverable	µg/L	52	---	81	16
Cyanide, Total	µg/L	17	---	44	5
Dioxin-TEQ	µg/L	1.4 x 10 <sup>-8</sup>	---	2.8 x 10 <sup>-8</sup>	0 <sup>[3]</sup>
Ammonia, Total	mg/L as N	67	---	130	45
Fecal Coliform Bacteria	MPN/100	200 <sup>[4]</sup>	---	400 <sup>[5]</sup>	1,600 <sup>[6]</sup>



Parameter	Units	Effluent Limitations			Monitoring Data (7/2013 – 11/2017)
		Monthly Average	Weekly Average	Daily Maximum	Highest Daily Discharge
Enterococcus Bacteria	MPN/100	35 <sup>[7]</sup>	---	---	2,420 <sup>[8]</sup>
Acute Toxicity	% survival	Not less than 90% (11-sample median)			5% <sup>[9]</sup>
		Not less than 70% (11-sample 90 <sup>th</sup> percentile)			
Chronic Toxicity	TU <sub>c</sub>	No chronic toxicity in discharge as discharged			13.5 <sup>[10]</sup>

Abbreviations:

- mg/L = milligrams per liter
- mg/L as N = milligrams per liter as nitrogen
- µg/L = micrograms per liter
- MPN/100 mL = most probable number per 100 milliliters
- DNQ = detected, but not quantified
- s.u. = standard units
- TU<sub>c</sub> = chronic toxicity units
- % = percent

Footnotes:

- <sup>[1]</sup> Lowest monthly average.
- <sup>[2]</sup> Range of lowest and highest pH values.
- <sup>[3]</sup> Dioxin-TEQ was calculated in accordance with the previous order’s Attachment G section V.C.1.d.iv.
- <sup>[4]</sup> This fecal coliform bacteria limitation was expressed as the geometric mean in a calendar month.
- <sup>[5]</sup> This fecal coliform bacteria limitation was expressed as the 90<sup>th</sup> percentile of the last eleven values.
- <sup>[6]</sup> The Discharger did not violate the previous order’s fecal coliform bacteria effluent limitations because the highest monthly geometric mean was 59 MPN/100 mL and the highest eleven-sample 90<sup>th</sup> percentile was 240 MPN/100mL.
- <sup>[7]</sup> This enterococcus bacteria limitation was expressed as the geometric mean of all samples in a calendar month.
- <sup>[8]</sup> The Discharger did not violate the previous order’s enterococcus bacteria effluent limitation because the highest monthly geometric mean was 28 MPN/100 mL.
- <sup>[9]</sup> Lowest percent survival. The low acute toxicity bioassay result did not constitute a violation because the lowest eleven-sample median was 90% and the lowest eleven-sample 90<sup>th</sup> percentile was 85%. Furthermore, the Discharger demonstrated that the low acute toxicity result was likely caused by ammonia, and the ammonia in the discharge complied with effluent limits.
- <sup>[10]</sup> The Discharger did not violate the narrative chronic toxicity limit because the highest recorded effluent toxicity (13.5 TU<sub>c</sub>) was less than the translated numeric chronic toxicity objective of 1.0 TU<sub>c</sub> (see Fact Sheet § IV.C.3.d) after receiving a minimum initial dilution of 74:1 upon discharge (see Fact Sheet § IV.C.4.b.iv).

**D. Compliance Summary**

- 1. Treatment Plant.** The Discharger did not violate its numeric effluent limitations during the previous permit term.
- 2. Collection System.** The table below shows the Discharger’s and satellite collection system agencies’ sanitary sewer overflow (SSO) rates (total SSOs per 100 miles of collection system) for the last four years, the lengths and ages of the collection systems, and comparisons to systems in the San Francisco Bay Region. All systems in the San Francisco Bay Region are responsible for reporting SSOs associated with mainlines, but only some are also responsible for reporting SSOs associated with laterals. The Discharger is responsible for reporting SSOs associated with mainlines and laterals and the satellite collection system agencies are responsible for reporting SSOs associated with mainlines only. SSOs that reach waters of the United States may violate Prohibition III.E of this Order.

**Table F-3. Collection System and SSO Rates (SSO per 100 miles)**  
 (Values based on CIWQS data analysis completed in February 2018) <sup>[1]</sup>

	Length (miles)	Average Age of Pipe (years)	Total SSO Rate			
			2013	2014	2015	2016
Discharger (mainlines and laterals)	118	72	13	11	7.6	11
Discharger (mainlines only)	87	72	5.7	16	3.4	5.7
Town of Hillsborough <sup>[2]</sup>	98	80	12	16	10	17
Burlingame Hills Sewer Maintenance District <sup>[3]</sup>	6.6	87	60	75	15	30
San Mateo County median of 9 large systems (≥100 miles)	167	59	7.0	7.3	2.4	5.0
San Mateo County median of 15 medium systems (10-99 miles)	37	46	6.4	11	9.6	5.6
San Mateo County median of 10 small systems (<10 miles)	4.3	49	21	24	4.5	24
San Francisco Bay Region median of 46 large systems (≥100 miles)	234	47	4.5	5.5	3.8	3.7
San Francisco Bay Region median of 49 medium systems (10-99 miles)	37	49	12	7.7	8.3	7.5
San Francisco Bay Region median of 37 small systems (<10 miles)	4.0	47	0	0	0	0
San Francisco Bay Region median of all 132 systems	46	47	5.7	6.3	3.8	4.2

Footnote:

- <sup>[1]</sup> The State Water Board’s *Enrollee’s Guide to the SSO Database* defines “Total number of SSOs per 100 miles of Sewer” as “...the number of SSOs, for which the reporting enrollee is responsible, for every 100 miles of pipe or sewer lines in an enrollee’s sanitary sewer system. Due to the large variation in facility specific characteristics, this metric should only be viewed as a rough comparison of the operation and maintenance performance of enrollees and their sanitary sewer systems.”
- <sup>[2]</sup> The Town of Hillsborough is a satellite collection system agency with approximately 43 miles of pipeline within the Burlingame Sewer Basin service area. Its remaining pipeline is within the San Mateo Sewer Basin.
- <sup>[3]</sup> The Burlingame Hills Sewer Maintenance District is a satellite collection system agency entirely within the Burlingame Sewer Basin service area.

During the most recent four years with available data (2013 – 2016), the Discharger’s SSO rates were above the median of other large collection systems in San Mateo County and above the median of all collection systems in the San Francisco Bay Region. The Discharger’s SSO rates associated with its mainlines only were above the median of other large collection systems in San Mateo County for three years (2014 – 2016), and above the median of all collection systems in the San Francisco Bay Region for two years (2014 and 2016). The average age of the Discharger’s collection system is approximately 72 years, which is significantly older than most other collection systems in San Mateo County and the San Francisco Bay Region. The satellite collection system agencies reported higher SSO rates, all above the medians of similarly-sized collection systems in San Mateo County and above the median of all collection systems in the San Francisco Bay Region.

Provision VI.C.5.a of this Order requires the Discharger to clean and inspect its collection system, and to complete at least \$18,000,000 of sewer pipe rehabilitation and improvements on its collection system. During the previous order term, the Discharger invested over \$18 million in collection system rehabilitation projects, resulting in the replacement of over 8 miles of its collection system. The Discharger also developed a Wet Weather Improvement

Plan to reduce inflow and infiltration. The Discharger implements a private sewer lateral ordinance within its service area and has agreements with the satellite collection system agencies requiring the satellite collection system agencies to properly maintain those collection systems as a condition of using the Plant. During the previous order term, the Town of Hillsborough invested approximately \$12.5 million in collection system rehabilitation projects within the Burlingame Sewer Basin, and the Burlingame Hills Sewer Maintenance District invested approximately \$1.6 million in increasing sewer capacity and upgrading materials. Both the Town of Hillsborough and the Burlingame Hills Sewer Maintenance District implement private sewer lateral ordinances.

#### **E. Planned Changes**

The Discharger does not anticipate any operational or process changes to the Facility during the term of this Order.

### **III. APPLICABLE PLANS, POLICIES, AND REGULATIONS**

#### **A. Legal Authorities**

This Order serves as WDRs pursuant to California Water Code article 4, chapter 4, division 7 (commencing with § 13260) for discharges to land and/or waters of the State. This Order is also issued pursuant to Clean Water Act (CWA) section 402 and implementing regulations adopted by U.S. EPA, and Water Code chapter 5.5, division 7 (commencing with § 13370). It shall serve as an NPDES permit authorizing the Discharger to discharge into waters of the United States at the discharge location described in Table 2 subject to the WDRs in this Order.

#### **B. California Environmental Quality Act**

Under Water Code section 13389, this action to adopt an NPDES permit is exempt from the provisions of the California Environmental Quality Act (CEQA), Public Resources Code division 13, chapter 3 (commencing with § 21100). Provisions and requirements in this Order implementing State law only are further exempt from CEQA pursuant to the categorical exemption for existing facilities (Cal. Code Regs., tit. 40, § 15301).

#### **C. State and Federal Regulations, Policies, and Plans**

**1. Water Quality Control Plan.** The Regional Water Board adopted the *Water Quality Control Plan for the San Francisco Bay Basin* (Basin Plan), which designates beneficial uses, establishes water quality objectives, and contains implementation programs and policies to achieve those objectives for all waters addressed through the plan. Requirements in this Order implement the Basin Plan. In addition, this Order implements State Water Board Resolution No. 88-63, which establishes State policy that all waters, with certain exceptions, should be considered suitable or potentially suitable for municipal or domestic supply. Because of the marine influence on Lower San Francisco Bay, total dissolved solids exceed 3,000 mg/L; therefore, Lower San Francisco Bay meets an exception to State Water Board Resolution No. 88-63. The table below lists beneficial uses applicable to Lower San Francisco Bay:

**Table F-4. Beneficial Uses**

Discharge Point	Receiving Water Name	Beneficial Uses	
002	Lower San Francisco Bay	Industrial Service Supply (IND) Commercial and Sport Fishing (COMM) Shellfish Harvesting (SHELL) Estuarine Habitat (EST) Fish Migration (MIGR) Preservation of Rare and Endangered Species (RARE)	Fish Spawning (SPWN) Wildlife Habitat (WILD) Water Contact Recreation (REC-1) Non-Contact Water Recreation (REC-2) Navigation (NAV)

2. **Sediment Quality.** The State Water Board adopted the *Water Quality Control Plan for Enclosed Bays and Estuaries – Part 1, Sediment Quality* on September 16, 2008, and it became effective on August 25, 2009. This plan supersedes other narrative sediment quality objectives, and establishes new sediment quality objectives and related implementation provisions for specifically defined sediments in most bays and estuaries. This Order implements the sediment quality objectives of this plan.
3. **National Toxics Rule (NTR) and California Toxics Rule (CTR).** U.S. EPA adopted the NTR on December 22, 1992, and amended it on May 4, 1995, and November 9, 1999. About 40 criteria in the NTR apply in California. On May 18, 2000, U.S. EPA adopted the CTR. The CTR promulgated new toxics criteria for California and incorporated the previously adopted NTR criteria that applied in the State. U.S. EPA amended the CTR on February 13, 2001. These rules contain water quality criteria for priority pollutants.
4. **State Implementation Policy.** On March 2, 2000, the State Water Board adopted the *Policy for Implementation of Toxics Standards for Inland Surface Waters, Enclosed Bays, and Estuaries of California* (State Implementation Policy or SIP). The SIP became effective on April 28, 2000, with respect to the priority pollutant criteria U.S. EPA promulgated for California through the NTR and the priority pollutant objectives the Regional Water Board established in the Basin Plan. The SIP became effective on May 18, 2000, with respect to the priority pollutant criteria U.S. EPA promulgated through the CTR. The State Water Board adopted amendments to the SIP on February 24, 2005, that became effective on July 13, 2005. The SIP establishes implementation provisions for priority pollutant criteria and objectives, and provisions for chronic toxicity control. Requirements of this Order implement the SIP.
5. **Antidegradation Policy.** Federal regulations at 40 C.F.R. section 131.12 require that state water quality standards include an antidegradation policy consistent with the federal policy. The State Water Board established California’s antidegradation policy through State Water Board Resolution No. 68-16, *Statement of Policy with Respect to Maintaining High Quality of Waters in California*, which is deemed to incorporate the federal antidegradation policy where the federal policy applies under federal law. Resolution No. 68-16 requires that existing water quality be maintained unless degradation is justified based on specific findings. The Basin Plan implements, and incorporates by reference, both the State and federal antidegradation policies. Permitted discharges must be consistent with the antidegradation provisions of 40 C.F.R. section 131.12 and State Water Board Resolution No. 68-16. (See Fact Sheet § IV.D.1 Antidegradation.)

- 6. Anti-Backsliding Requirements.** CWA sections 402(o) and 303(d)(4) and 40 C.F.R. section 122.44(l) restrict backsliding in NPDES permits. These anti-backsliding provisions require that effluent limitations in a reissued permit be as stringent as those in the previous permit, with some exceptions in which limitations may be relaxed. (See Fact Sheet § IV.D.2 Anti-Backsliding.)
- 7. Endangered Species Act Requirements.** This Order does not authorize any act that results in the taking of a threatened or endangered species or any act that is now prohibited, or becomes prohibited in the future, under either the California Endangered Species Act (Fish and Game Code §§ 2050 to 2097) or the Federal Endangered Species Act (16 U.S.C.A. §§ 1531 to 1544). This Order requires compliance with effluent limits, receiving water limits, and other requirements to protect the beneficial uses of waters of the State, including protecting rare, threatened, or endangered species. The Discharger is responsible for meeting all applicable Endangered Species Act requirements.
- 8. Sludge and Biosolids.** U.S. EPA administers 40 C.F.R. Part 503, Standards for the Use or Disposal of Sewage Sludge, which regulates the final use or disposal of sewage sludge generated during the treatment of domestic sewage in a municipal wastewater treatment facility. This Order does not authorize any act that violates those requirements. The Discharger is responsible for meeting all applicable requirements of 40 C.F.R. Part 503.

#### **D. Impaired Waters on CWA 303(d) List**

On July 30, 2015, U.S. EPA approved a revised list of impaired waters prepared pursuant to CWA section 303(d), which requires identification of specific water bodies where it is expected that water quality standards will not be met after implementation of technology-based effluent limitations on point sources. Where it has not done so already, the Regional Water Board plans to adopt total maximum daily loads (TMDLs) for pollutants on the 303(d) list. TMDLs establish wasteload allocations for point sources and load allocations for non-point sources and are established to achieve the water quality standards for the impaired waters.

Lower San Francisco Bay is 303(d)-listed as impaired by chlordane, DDT, dieldrin, dioxin compounds, furan compounds, invasive species, mercury, PCBs, dioxin-like PCBs, and trash. On February 12, 2008, U.S. EPA approved a TMDL for mercury in San Francisco Bay. On March 29, 2010, U.S. EPA approved a TMDL for PCBs in San Francisco Bay. The mercury and PCBs TMDLs apply to this discharge and are implemented through NPDES Permit No. CA0038849.

As shown in Fact Sheet section IV.C.3, the discharge is not a significant source of chlordane, DDT, or dieldrin because these pollutants have not been detected in the discharge. The discharge is not a source of invasive species because it is disinfected. It is not a source of trash because it is screened and treated to secondary treatment standards. It is an insignificant source of dioxins and furans; this Order contains dioxin-TEQ effluent limitations to ensure that dioxins and furans in effluent are kept below water quality objectives.

#### **IV. RATIONALE FOR EFFLUENT LIMITATIONS AND DISCHARGE SPECIFICATIONS**

The CWA requires point source dischargers to control the amount of conventional, non-conventional, and toxic pollutants discharged into waters of the United States. The control of pollutants discharged is established through effluent limitations and other requirements in NPDES

permits. There are two principal bases for effluent limitations: 40 C.F.R. section 122.44(a) requires that permits include applicable technology-based limitations and standards; and 40 C.F.R. section 122.44(d) requires that permits include water quality-based effluent limitations to attain and maintain applicable numeric and narrative water quality criteria to protect the beneficial uses of receiving waters.

## A. Discharge Prohibitions

- 1. Discharge Prohibition III.A (No discharge at location or in manner different than described in this Order):** This prohibition is based on 40 C.F.R. section 122.21(a) and Water Code section 13260, which require filing an application and Report of Waste Discharge before a discharge can occur. Discharges not described in the application and Report of Waste Discharge, and subsequently in this Order, are prohibited.
- 2. Discharge Prohibition III.B (No discharge without initial dilution of at least 74:1, as modeled):** The water quality-based effluent limitations in this Order are based on the mixing zones and dilution credits explained in Fact Sheet section IV.C.4. This prohibition is necessary to ensure that this Order's effluent limitations remain protective of water quality.
- 3. Discharge Prohibition III.C (No bypass to waters of United States):** This prohibition is based on 40 C.F.R. section 122.41(m) (see Attachment D § I.G). Bypass is prohibited. When influent flow is greater than 13.5 MGD, however, bypass is approved for the portion of the flow greater than 13.5 MGD. Under these conditions, excess flows may bypass biological treatment and be blended with effluent receiving biological treatment. All flows must be disinfected prior to discharge and comply with all effluent and receiving water limitations contained in this Order.

The Discharger meets the criteria required for the Regional Water Board to approve these bypasses as follows (40 C.F.R. sections 122.41(m)(4)(i)(A)-(C)):

- **Bypass is unavoidable to prevent loss of life, personal injury, or severe property damage.** Bypass is unavoidable during periods of heavy rain to prevent damage to the biological treatment units and effluent conveyance system. When primary effluent flow is greater than 13.5 MGD (the maximum biological treatment capacity), bypassing some flows around biological treatment prevents the washout of solids and the microbial population from the biological treatment system.
- **There are no feasible alternatives to the bypass.** The Discharger maintains substantial equalization and onsite storage capacity, including a 0.4-MG offline primary clarifier, a 1.6-MG stormwater retention basin, and a 0.3-MG offline aeration basin. Due to space constraints, further improvements at the Plant would be cost-prohibitive, particularly in light of how rare wet weather bypasses are. Reducing wet weather flows through collection system improvements is the most practical approach to minimize wet weather bypasses. The Discharger has adopted and implemented a private sewer lateral ordinance and has agreements with its satellite collection system agencies regarding the maintenance and operation of their collection systems. Both satellite collection system agencies also have private sewer lateral ordinances. During the previous order term, the Discharger developed a Wet Weather Improvement Plan to establish measurable goals to minimize and eventually eliminate wet weather bypasses. Continued collection system

improvements will aim to reduce inflow and infiltration. Provision VI.C.5.a requires the Discharger to implement specific tasks to reduce wet weather bypasses.

- **The Discharger provided notice at least ten days before the date of the bypass.** The Discharger provided notice of these anticipated wet weather bypasses to the Regional Water Board with its Report of Waste Discharge on December 29, 2017.

The Regional Water Board may approve anticipated bypasses after considering their adverse effects. In this case, adverse effects will be minimal because the bypasses must comply with all effluent limits. Furthermore, the bypasses will occur rarely and only during peak wet weather events (see Fact Sheet § II.A.3), when tidal mixing will greatly dilute the discharge in Lower San Francisco Bay.

- 4. Discharge Prohibition III.D (No average dry weather flow in excess of 5.5 MGD):** This Order prohibits average dry weather influent flows greater than the plant’s design average dry weather treatment capacity (i.e., its historical and tested treatment reliability) of 5.5 MGD. Exceeding this flow could result in lower treatment reliability and greater potential to violate water quality requirements.
- 5. Discharge Prohibition III.E (No sanitary sewer overflows to waters of the United States):** Basin Plan Table 4-1, Discharge Prohibition 15, and the CWA prohibit the discharge of wastewater to surface waters, except as authorized under an NPDES permit. POTWs must achieve secondary treatment at a minimum and any more stringent limitations necessary to meet water quality standards (33 U.S.C. § 1311(b)(1)(B) and (C)). A sanitary sewer overflow that results in the discharge of raw sewage or wastewater not meeting this Order’s effluent limitations to waters of the United States is therefore prohibited under the Basin Plan and the CWA.

## B. Technology-Based Effluent Limitations

### 1. Scope and Authority

CWA section 301(b) and 40 C.F.R. section 122.44 require that permits include conditions meeting technology-based requirements, at a minimum, and any more stringent effluent limitations necessary to meet water quality standards. The discharges authorized by this Order must meet minimum federal technology-based requirements based on the Secondary Treatment Standards at 40 C.F.R. section 133 as summarized below. In addition, the 30-day average percent removal for biochemical oxygen demand (BOD<sub>5</sub>) (or carbonaceous biochemical demand, CBOD<sub>5</sub>) and total suspended solids (TSS), by concentration, is not to be less than 85 percent. The Basin Plan contains additional requirements for certain pollutants.

**Table F-5. Secondary Treatment Standards**

Parameter	Monthly Average	Weekly Average
BOD <sub>5</sub> <sup>[1,2]</sup>	30 mg/L	45 mg/L
CBOD <sub>5</sub> <sup>[1,2]</sup>	25 mg/L	40 mg/L
TSS <sup>[2]</sup>	30 mg/L	45 mg/L
pH	6.0 – 9.0 standard units	

Abbreviation:

mg/L = milligrams per liter

Footnotes:

- <sup>[1]</sup> CBOD<sub>5</sub> effluent limitations may be substituted for BOD<sub>5</sub> limitations.  
<sup>[2]</sup> The monthly average percent removal, by concentration, is not to be less than 85 percent.

## 2. Effluent Limitations

- a. **BOD<sub>5</sub> and TSS.** The BOD<sub>5</sub> and TSS effluent limitations, including the 85 percent removal requirements, are based on the Secondary Treatment Standards and Basin Plan Table 4-2.
- b. **Oil and Grease.** The oil and grease effluent limitations are based on Basin Plan Table 4-2.
- c. **pH.** The pH effluent limitations are based on the Secondary Treatment Standards and Basin Plan Table 4-2.
- d. **Total Chlorine Residual.** The chlorine residual effluent limitation is based on Basin Plan Table 4-2. The Monitoring and Reporting Program (MRP, Attachment E) provides an allowance for determining false positives when using continuous devices based on the fact that continuous instruments occasionally have anomalous spikes, and it is chemically improbable to have free chlorine in the presence of sodium bisulfite. The allowance for using only on-the-hour measurements for mandatory minimum penalty assessment purposes under Water Code section 13385.1 is based on a 2004 strategy developed between the Regional Water Board and the Bay Area Clean Water Agencies.
- e. **Enterococcus Bacteria.** The enterococcus effluent limitation is based on Basin Plan Table 4-2A, which requires this limitation for discharges to receiving waters with the water contact recreation beneficial use.

## C. Water Quality-Based Effluent Limitations (WQBELs)

### 1. Scope and Authority

This Order contains WQBELs that protect beneficial uses. CWA section 301(b) and 40 C.F.R. section 122.44(d) require that permits include limitations more stringent than federal technology-based requirements where necessary to achieve applicable water quality standards. According to 40 C.F.R. section 122.44(d)(1)(i), permits must include effluent limitations for all pollutants that are or may be discharged at levels that have a reasonable potential to cause or contribute to an exceedance of a water quality standard, including numeric and narrative objectives within a standard. Where reasonable potential has been established for a pollutant, but there is no numeric criterion or objective, WQBELs must be established using (1) U.S. EPA criteria guidance under CWA section 304(a), supplemented where necessary by other relevant information; (2) an indicator parameter for the pollutant of concern; or (3) a calculated numeric water quality criterion, such as a proposed state criterion or policy interpreting a narrative criterion, supplemented with relevant information (40 C.F.R. § 122.44 (d)(1)(vi)). The process for determining reasonable potential and calculating WQBELs is intended to achieve applicable water quality objectives and criteria, and to protect designated uses of receiving waters as specified in the Basin Plan.



## 2. Beneficial Uses and Water Quality Criteria and Objectives

Discharge Point No. 002 discharges to Lower San Francisco Bay. Fact Sheet section III.C.1 identifies the beneficial uses of Lower San Francisco Bay. Water quality criteria and objectives to protect these beneficial uses are described below:

- a. **Basin Plan Objectives.** The Basin Plan specifies numerous water quality objectives, including numeric objectives for 10 priority pollutants and un-ionized ammonia, and narrative objectives for toxicity and bioaccumulation.
  - i. **Ammonia.** Basin Plan section 3.3.20 contains water quality objectives for un-ionized ammonia of 0.025 mg/L as an annual median and 0.4 mg/L as a maximum for Lower San Francisco Bay. Effluent and receiving water data are available for total ammonia, but not un-ionized ammonia, because (1) sampling and laboratory methods are unavailable to analyze for un-ionized ammonia, and (2) the fraction of total ammonia that exists in the toxic un-ionized form depends on pH, salinity, and temperature of the receiving water.

To translate the un-ionized ammonia objectives into total ammonia criteria, pH, salinity, and temperature data collected through the Regional Monitoring Program (RMP) at the San Bruno Shoal monitoring station (BB15) between 1994 and 2001 were used. The un-ionized fraction of the total ammonia was calculated using the following equation, which applies to waters with salinities greater than 10 parts per thousand (Ambient Water Quality Criteria for Ammonia (Saltwater)–1989, EPA Publication 440/5-88-004, 1989):

$$\text{For salinity} > 10 \text{ ppt: fraction of NH}_3 = \frac{1}{1 + 10^{(pK - pH)}}$$

Where:

$$pK = 9.245 + 0.116*(I) + 0.0324*(298-T) + 0.0415*(P)/T$$

*I* = the molal ionic strength of saltwater = 19.9273\*(S)/(1000-1.005109\*S)  
*S* = salinity (parts per thousand)  
*T* = temperature in Kelvin  
*P* = pressure (one atmosphere)

The 90th percentile and median un-ionized ammonia fractions were then used to express the maximum and annual average un-ionized objectives as acute and chronic total ammonia criteria. This approach is consistent with U.S. EPA guidance on translating dissolved metal water quality objectives to total recoverable metal water quality criteria (U.S. EPA, 1996, *The Metals Translator: Guidance for Calculating a Total Recoverable Limit from a Dissolved Criterion*, EPA Publication 823-B96-007). The equivalent acute and chronic total ammonia criteria are 11 mg/L and 0.94 mg/L (as nitrogen).

- ii. **Dioxin-TEQ.** The narrative bioaccumulation objective (Basin Plan section 3.3.2) states, “Many pollutants can accumulate on particulates, in sediments, or bioaccumulate in fish and other aquatic organisms. Controllable water quality factors shall not cause a detrimental increase in concentrations of toxic substances found in bottom sediments or aquatic life. Effects on aquatic organisms, wildlife, and human

health will be considered.” Because it is the consensus of the scientific community that dioxins and furans associate with particulates, accumulate in sediments, and bioaccumulate in the fatty tissue of fish and other organisms, the Basin Plan’s narrative bioaccumulation water quality objective applies to these pollutants. Elevated levels of dioxins and furans in San Francisco Bay fish tissue demonstrate that the narrative bioaccumulation water quality objective is not being met. U.S. EPA has therefore placed Lower San Francisco Bay on its 303(d) list of receiving waters where water quality objectives are not being met after imposition of applicable technology-based requirements.

When the CTR was promulgated, U.S. EPA stated its support for the regulation of dioxin and dioxin-like compounds through the use of toxicity equivalencies (TEQs). U.S. EPA stated, “For California waters, if the discharge of dioxin or dioxin-like compounds has reasonable potential to cause or contribute to a violation of a narrative criterion, numeric water quality-based effluent limits for dioxin or dioxin-like compounds should be included in NPDES permits and should be expressed using a TEQ scheme” (Fed. Reg. Vol. 65, No. 97, pages 31695-31696, May 18, 2000). This Order uses a TEQ scheme based on a set of toxicity equivalency factors (TEFs) the World Health Organization developed in 2005, and a set of bioaccumulation equivalency factors (BEFs) U.S. EPA developed for the Great Lakes region (40 C.F.R. § 132, Appendix F) to convert the concentration of any congener of dioxin or furan into an equivalent concentration of 2,3,7,8-tetrachlorinated dibenzo-p-dioxin (2,3,7,8-TCDD). Although the 2005 World Health Organization scheme includes TEFs for dioxin-like PCBs, they are not included in this Order’s TEQ scheme. The CTR has established a specific water quality criterion for PCBs, and dioxin-like PCBs are included in the analysis of total PCBs.

The CTR establishes a numeric water quality objective for 2,3,7,8-TCDD of  $1.4 \times 10^{-8}$  µg/L for the protection of human health when aquatic organisms are consumed. This CTR criterion is used as a criterion for dioxin TEQ because dioxin-TEQ represents a toxicity-weighted concentration equivalent to 2,3,7,8-TCDD, thus translating the narrative bioaccumulation objective into a numeric criterion.

- iii. Chronic Toxicity.** The narrative toxicity objective (Basin Plan section 3.3.18) states, “All waters shall be maintained free of toxic substances in concentrations that are lethal to or that produce other detrimental responses in aquatic organisms.... There shall be no chronic toxicity in ambient waters. Chronic toxicity is a detrimental biological effect on growth rate, reproduction, fertilization success, larval development, population abundance, community composition, or any other relevant measure of the health of an organism, population, or community. Attainment of this objective will be determined by analyses of indicator organisms, species diversity, population density, growth anomalies, or toxicity tests..., or other methods selected by the Water Board.”

For this Order, this narrative objective is translated into a numeric criterion of 1.0 chronic toxicity unit (TU<sub>c</sub>). At 1.0 TU<sub>c</sub>, there is no observable detrimental effect when the indicator organism is exposed to 100 percent effluent; therefore, 1.0 TU<sub>c</sub> is a direct translation of the narrative objective into a number. Moreover, in U.S. EPA’s

*Technical Support Document for Water Quality-based Toxics Control* (EPA/505/2-90-001; see section 3.3.3, “Step 3: Decision Criteria for Permit Limit Development”), U.S. EPA recommends that 1.0 TU<sub>c</sub> be used as a criterion continuous concentration (typically a four-day average). It further states that reasonable potential is shown where an effluent is projected to cause an excursion above the criterion continuous concentration. This document applies here as guidance because it directly addresses effluent characterization for toxicity.

- b. CTR Criteria.** The CTR specifies numeric aquatic life and human health criteria for numerous priority pollutants. These criteria apply to inland surface waters and enclosed bays and estuaries. Some human health criteria are for consumption of “water and organisms” and others are for consumption of “organisms only.” The criteria applicable to “organisms only” apply to Lower San Francisco Bay because it is not a source of drinking water.
- c. NTR Criteria.** The NTR establishes numeric aquatic life and human health criteria for a number of toxic pollutants for San Francisco Bay waters upstream to and including Suisun Bay and the Sacramento-San Joaquin Delta. The NTR criteria apply to Lower San Francisco Bay.
- d. Sediment Quality Objectives.** The *Water Quality Control Plan for Enclosed Bays and Estuaries – Part 1, Sediment Quality* contains the following narrative water quality objective: “Pollutants in sediments shall not be present in quantities that, alone or in combination, are toxic to benthic communities in bays and estuaries of California.” This objective is to be implemented by integrating three lines of evidence: sediment toxicity, benthic community condition, and sediment chemistry. The policy requires that if the Regional Water Board determines that a discharge has reasonable potential to cause or contribute to an exceedance of this objective, it is to impose the objective as a receiving water limit.
- e. Receiving Water Salinity.** Basin Plan section 4.6.2 (like the CTR and NTR) states that the salinity characteristics (i.e., freshwater vs. saltwater) of the receiving water are to be considered in determining the applicable water quality objectives. Freshwater criteria apply to discharges to waters with salinities equal to or less than one part per thousand (ppt) at least 95 percent of the time. Saltwater criteria apply to discharges to waters with salinities equal to or greater than 10 ppt at least 95 percent of the time in a normal water year. For discharges to waters with salinities between these two categories, or tidally-influenced freshwaters that support estuarine beneficial uses, the water quality objectives are the lower of the salt or freshwater objectives (the latter calculated based on ambient hardness) for each substance.

Lower San Francisco Bay is a saltwater environment based on salinity data collected through the RMP. Historically, the RMP conducted sampling at 26 locations throughout the San Francisco Bay region. In 2002, the system was redesigned to incorporate random sampling in place of the 26 established locations. Salinity data collected at the San Bruno Shoal monitoring station (BB15) and the Alameda monitoring station (BB70) between 1993 and 2001, and additional random sampling at various locations within Lower San Francisco Bay collected from 2002 to 2009, indicate that the salinity was greater than

10 ppt in 100 percent of the samples. Therefore, the reasonable potential analysis and effluent limitations in this Order are based on saltwater water quality objectives.

- f. **Site-Specific Metals Translators.** Effluent limitations for metals must be expressed as total recoverable metal (40 C.F.R. § 122.45(c)). Since the water quality objectives for metals are typically expressed as dissolved metals, translators must be used to convert metals concentrations from dissolved to total recoverable and vice versa. The CTR contains default translators; however, site-specific conditions, such as water temperature, pH, total suspended solids, and organic carbon may affect the form of metal (dissolved, non-filterable, or otherwise) present and therefore available to cause toxicity. In general, dissolved metals are more available and more toxic to aquatic life than other forms. Site-specific translators can account for site-specific conditions, thereby preventing overly stringent or under-protective water quality objectives.

CTR default translators were used for all metals other than copper and nickel. Basin Plan Table 7.2.1-2 sets forth site-specific copper translators. The Clean Estuary Partnership’s *North of Dumbarton Bridge Copper and Nickel Development and Selection of Final Translators* (March 2005) contains site-specific nickel translators. These translators are listed in the table below:

**Table F-6. Site-Specific Translators**

Parameter	Site Specific Translators	
	Acute	Chronic
Copper	0.87	0.73
Nickel	0.85	0.65

**3. Need for Water Quality-Based Effluent Limitations (Reasonable Potential Analysis)**

Assessing whether a pollutant has reasonable potential to exceed a water quality objective is the fundamental step in determining whether a WQBEL is required.

- a. **Available Information.** The reasonable potential analysis for this Order is based on effluent monitoring data the Discharger collected from July 2013 through November 2017 and ambient background data summarized in *San Francisco Bay California Toxics Rule Priority Pollutant Ambient Water Monitoring Report* (2017), which includes data collected through the RMP at the Yerba Buena monitoring station (BC10) from March 1993 through August 2015, supplemented by additional Bay Area Clean Water Agencies data from *San Francisco Bay Ambient Water Monitoring Interim Report* (2003) and *Ambient Water Monitoring: Final CTR Sampling Update* (2004).

SIP section 1.4.3 requires that background water quality data be representative of the ambient receiving water that will mix with the discharge. For the priority pollutants, the Yerba Buena RMP monitoring station (BC10), relative to other RMP stations, best fits SIP guidance for establishing background conditions at Discharge Point No. 002. For ammonia, the nearby San Bruno Shoal RMP monitoring station (BB15), relative to other RMP locations, best fits SIP guidance for establishing background conditions because the ammonia WQBELs are based on actual dilution at the edge of the initial mixing zone and data from monitoring station BB15 best represents water quality at the edge of the initial mixing zone.

This Order does not contain WQBELs for constituents that do not demonstrate reasonable potential; however, Provision VI.C.2 of the Order still requires monitoring for those pollutants. If concentrations are found to have increased significantly, Provision VI.C.2 of the Order requires the Discharger to investigate the sources of the increases and implement remedial measures if the increases pose a threat to receiving water quality.

**b. Priority Pollutants, Ammonia, and Dioxin-TEQ**

**i. Methodology.** SIP section 1.3 sets forth the methodology used for this Order for assessing whether a priority pollutant has reasonable potential to exceed a water quality objective. SIP section 1.3 applies to priority pollutants and is used here for dioxin-TEQ and ammonia as guidance. The analysis begins with identifying the maximum effluent concentration (MEC) observed for each pollutant based on available effluent concentration data and the ambient background concentration (B). SIP section 1.4.3 states that ambient background concentrations are either the maximum ambient concentration observed or, for water quality objectives intended to protect human health, the arithmetic mean of observed concentrations. There are three triggers in determining reasonable potential:

- (a) **Trigger 1** is activated if the maximum effluent concentration is greater than or equal to the lowest applicable water quality objective ( $MEC \geq$  water quality objective).
- (b) **Trigger 2** is activated if the ambient background concentration observed in the receiving water is greater than the lowest applicable water quality objective ( $B >$  water quality objective) *and* the pollutant is detected in any effluent sample.
- (c) **Trigger 3** is activated if a review of other information indicates that a WQBEL is needed to protect beneficial uses.

**ii. Analysis.** The maximum effluent concentrations, most stringent applicable water quality criteria and objectives, and ambient background concentrations used in the analysis are presented in the following table, along with the reasonable potential analysis results (yes, no, or unknown) for each pollutant. Basin Plan sections 7.2.1.2 and 4.7.2.2 require copper and cyanide WQBELs for all individual NPDES permits for municipal wastewater treatment facilities that discharge to San Francisco Bay.

**Table F-7. Reasonable Potential Analysis**

CTR No.	Priority Pollutants	C or Governing criterion or objective (µg/L)	MEC or Minimum DL (µg/L) <sup>[1][2]</sup>	B or Minimum DL (µg/L) <sup>[1][2]</sup>	RPA Results <sup>[3]</sup>
1	Antimony	4,300	0.50	1.8	No
2	Arsenic	36	2.9	2.5	No
3	Beryllium	No Criteria	<0.060	0.22	U
4	Cadmium	9.4	0.060 DNQ	0.13	No
5a	Chromium (III) <sup>[4]</sup>	No Criteria	1.5	4.4	U
5b	Chromium (VI) <sup>[4]</sup>	50	1.5	4.4	No
<b>6</b>	<b>Copper</b>	<b>8.2</b>	<b>16</b>	<b>2.5</b>	<b>Yes <sup>[5]</sup></b>

CTR No.	Priority Pollutants	C or Governing criterion or objective (µg/L)	MEC or Minimum DL (µg/L) <sup>[1][2]</sup>	B or Minimum DL (µg/L) <sup>[1][2]</sup>	RPA Results <sup>[3]</sup>
7	Lead	8.5	0.80	0.80	No
8	Mercury <sup>[6]</sup>	---	---	---	---
9	Nickel	13	7.2	3.7	No
10	Selenium	5.0	0.56 DNQ	0.39	No
11	Silver	2.2	0.04 DNQ	0.052	No
12	Thallium	6.3	<0.050	0.023	No
13	Zinc	86	44	5.1	No
<b>14</b>	<b>Cyanide</b>	<b>2.9</b>	<b>5.0</b>	<b>0.52</b>	<b>Yes <sup>[5]</sup></b>
15	Asbestos <sup>[7]</sup>	---	---	---	---
16	2,3,7,8-TCDD	1.4E-08	<4.7E-07	2.7E-08	No
	<b>Dioxin-TEQ</b>	<b>1.4E-08</b>	<b>2.2E-09</b>	<b>4.1E-08</b>	<b>Yes</b>
17	Acrolein	780	<1.7	<0.50	No
18	Acrylonitrile	0.66	<0.69	0.030	No
19	Benzene	71	<0.18	<0.050	No
20	Bromoform	360	2.2	<0.15	No
21	Carbon Tetrachloride	4.4	<0.16	0.060	No
22	Chlorobenzene	21,000	<0.18	<0.18	No
23	Chlorodibromomethane	34	4.6	<0.050	No
24	Chloroethane	No Criteria	<0.38	<0.38	U
25	2-Chloroethylvinyl ether	No Criteria	<0.28	<0.28	U
26	Chloroform	No Criteria	2.7	<0.19	U
27	Dichlorobromomethane	46	5.0	<0.050	No
28	1,1-Dichloroethane	No Criteria	<0.19	<0.050	U
29	1,2-Dichloroethane	99	<0.18	0.040	No
30	1,1-Dichloroethylene	3.2	<0.21	<0.21	No
31	1,2-Dichloropropane	39	<0.18	<0.050	No
32	1,3-Dichloropropylene	1,700	<0.16	<0.16	No
33	Ethylbenzene	29,000	<0.25	<0.26	No
34	Methyl Bromide	4,000	<0.25	<0.30	No
35	Methyl Chloride	No Criteria	<0.25	<0.30	U
36	Methylene Chloride	1,600	1.2 DNQ	22	No
37	1,1,2,2-Tetrachloroethane	11	<0.010	<0.050	No
38	Tetrachloroethylene	8.9	<0.19	<0.050	No
39	Toluene	200,000	0.25 DNQ	<0.19	No
40	1,2-Trans-Dichloroethylene	140,000	<0.22	<0.22	No
41	1,1,1-Trichloroethane	No Criteria	<0.19	<0.19	U
42	1,1,2-Trichloroethane	42	<0.16	<0.050	No
43	Trichloroethylene	81	<0.20	<0.20	No
44	Vinyl Chloride	530	<0.25	<0.25	No
45	2-Chlorophenol	400	<0.70	<0.70	No
46	2,4-Dichlorophenol	790	<0.90	<0.90	No
47	2,4-Dimethylphenol	2,300	<0.46	<0.80	No

CTR No.	Priority Pollutants	C or Governing criterion or objective (µg/L)	MEC or Minimum DL (µg/L) <sup>[1][2]</sup>	B or Minimum DL (µg/L) <sup>[1][2]</sup>	RPA Results <sup>[3]</sup>
48	2-Methyl- 4,6-Dinitrophenol	770	<0.020	<0.60	No
49	2,4-Dinitrophenol	14,000	<0.90	<0.70	No
50	2-Nitrophenol	No Criteria	<0.80	<0.80	U
51	4-Nitrophenol	No Criteria	<0.50	<0.50	U
52	3-Methyl 4-Chlorophenol	No Criteria	<0.80	<0.80	U
53	Pentachlorophenol	7.9	<0.60	<0.60	No
54	Phenol	4,600,000	<0.50	<0.50	No
55	2,4,6-Trichlorophenol	6.5	<0.96	<0.97	No
56	Acenaphthene	2,700	<0.020	0.0020	No
57	Acenaphthylene	No Criteria	<0.020	0.0010	U
58	Anthracene	110,000	<0.010	0.0010	No
59	Benzidine	0.00054	<5.0	<0.00030	U
60	Benzo(a)Anthracene	0.049	<0.020	0.0050	No
61	Benzo(a)Pyrene	0.049	<0.020	0.0020	No
62	Benzo(b)Fluoranthene	0.049	<0.020	0.0050	No
63	Benzo(ghi)Perylene	No Criteria	<0.030	0.0030	U
64	Benzo(k)Fluoranthene	0.049	<0.010	0.0020	No
65	Bis(2-Chloroethoxy)Methane	No Criteria	<0.90	<0.30	U
66	Bis(2-Chloroethyl)Ether	1.4	<0.70	<0.30	No
67	Bis(2-Chloroisopropyl)Ether	170,000	<0.60	<0.60	No
68	Bis(2-Ethylhexyl)Phthalate	5.9	2.4 DNQ	<0.50	No
69	4-Bromophenyl Phenyl Ether	No Criteria	<0.70	<0.23	U
70	Butylbenzyl Phthalate	5,200	<0.70	<0.50	No
71	2-Chloronaphthalene	4,300	<0.90	<0.30	No
72	4-Chlorophenyl Phenyl Ether	No Criteria	<0.90	<0.30	U
73	Chrysene	0.049	<0.020	0.0020	No
74	Dibenzo(a,h)Anthracene	0.049	<0.030	0.0010	No
75	1,2-Dichlorobenzene	17,000	<0.25	<0.27	No
76	1,3-Dichlorobenzene	2,600	<0.18	<0.18	No
77	1,4-Dichlorobenzene	2,600	<0.18	<0.18	No
78	3,3 Dichlorobenzidine	0.077	<5.0	<0.00020	No
79	Diethyl Phthalate	120,000	<0.70	<0.20	No
80	Dimethyl Phthalate	2,900,000	<0.90	<0.20	No
81	Di-n-Butyl Phthalate	12,000	<0.60	<0.50	No
82	2,4-Dinitrotoluene	9.1	<0.70	<0.27	No
83	2,6-Dinitrotoluene	No Criteria	<0.80	<0.29	U
84	Di-n-Octyl Phthalate	No Criteria	1.6 DNQ	<0.38	U
85	1,2-Diphenylhydrazine	0.54	<0.70	0.0040	No
86	Fluoranthene	370	<0.030	0.011	No
87	Fluorene	14,000	<0.010	0.0020	No
88	Hexachlorobenzene	0.00077	<0.70	0.000020	No
89	Hexachlorobutadiene	50	<0.60	<0.30	No
90	Hexachlorocyclopentadiene	17,000	<0.70	<0.30	No

CTR No.	Priority Pollutants	C or Governing criterion or objective (µg/L)	MEC or Minimum DL (µg/L) <sup>[1][2]</sup>	B or Minimum DL (µg/L) <sup>[1][2]</sup>	RPA Results <sup>[3]</sup>
91	Hexachloroethane	8.9	<0.60	<0.20	No
92	Indeno(1,2,3-cd)Pyrene	0.049	<0.020	0.0040	No
93	Isophorone	600	<0.93	<0.30	No
94	Naphthalene	No Criteria	<0.020	0.009	U
95	Nitrobenzene	1,900	<0.90	<0.25	No
96	N-Nitrosodimethylamine	8.1	<0.50	<0.30	No
97	N-Nitrosodi-n-Propylamine	1.4	<0.80	<0.00020	No
98	N-Nitrosodiphenylamine	16	<0.50	<0.0010	No
99	Phenanthrene	No Criteria	<0.020	0.0060	U
100	Pyrene	11,000	<0.020	0.019	No
101	1,2,4-Trichlorobenzene	No Criteria	<0.060	<0.30	U
102	Aldrin	0.00014	<0.0014	<0.0000085	No
103	Alpha-BHC	0.013	<0.0024	0.00050	No
104	Beta-BHC	0.046	<0.0038	0.00040	No
105	Gamma-BHC	0.063	<0.0029	0.0010	No
106	Delta-BHC	No Criteria	<0.0033	0.00010	U
107	Chlordane	0.00059	<0.020	0.00014	No
108	4,4'-DDT	0.00059	<0.0038	0.00020	No
109	4,4'-DDE	0.00059	<0.0029	0.0010	No
110	4,4'-DDD	0.00084	<0.0038	0.00030	No
111	Dieldrin	0.00014	<0.0019	0.00030	No
112	Alpha-Endosulfan	0.0087	<0.0029	0.00010	No
113	Beta-Endosulfan	0.0087	<0.0019	0.00010	No
114	Endosulfan Sulfate	240	<0.0029	0.00010	No
115	Endrin	0.0023	<0.0019	0.000040	No
116	Endrin Aldehyde	0.81	<0.0019	<0.0050	U
117	Heptachlor	0.00021	<0.0029	0.000020	No
118	Heptachlor Epoxide	0.00011	<0.0024	0.00010	No
119-125	PCBs sum <sup>[6]</sup>	---	---	---	---
126	Toxaphene	0.0002	<0.24	<8.2E-07	U
	<b>Ammonia, Total as N</b>	<b>0.94 mg/L</b>	<b>45 mg/L</b>	<b>0.19 mg/L</b>	<b>Yes</b>

Abbreviations:

- B = background concentration
- C = water quality criterion or objective
- DL = detection level
- MEC = maximum effluent concentration
- RPA = reasonable potential analysis
- µg/L = micrograms per liter
- mg/L = milligrams per liter

Footnotes:

- <sup>[1]</sup> The MEC and ambient background concentration are the actual detected concentrations unless preceded by a “<” sign, in which case the value shown is the minimum detection level (DL).
- <sup>[2]</sup> The MEC or ambient background concentration is “Unavailable” when there are no monitoring data for the constituent.



- [3] RPA Results = Yes, if  $MEC \geq WQC$ ,  $B > WQC$  and MEC is detected, or Trigger 3  
= No, if MEC and B are  $< WQC$  or all effluent data are undetected  
= Unknown (U) if no criteria have been promulgated or data are insufficient.
- [4] The maximum effluent and ambient background concentrations are the total chromium concentration. The chromium (III) and chromium (IV) concentrations are less than these values but unknown.
- [5] Reasonable potential is based in part on Basin Plan sections 7.2.1.2 and 4.7.2.2.
- [6] SIP section 1.3 excludes from its reasonable potential analysis procedure priority pollutants for which a TMDL has been developed. TMDLs have been developed for mercury and PCBs in San Francisco Bay. Mercury and PCBs from wastewater discharges are regulated by NPDES Permit No. CA0038849, which implements the San Francisco Bay Mercury and PCBs TMDLs.
- [7] Asbestos sampling is only required for discharges to waters with the municipal or domestic supply (MUN) beneficial use.

**c. Acute Toxicity.** Basin Plan section 4.5.5.3.1 requires acute toxicity monitoring and limitations, implying there is reasonable potential for the discharge to cause or contribute to exceedances of the acute toxicity water quality objective.

**d. Chronic Toxicity.** The *Technical Support Document for Water Quality-based Toxics Control* allows for dilution credits to be considered when conducting a reasonable potential analysis. This Order establishes a chronic toxicity dilution credit of 74:1 ( $D = 73$ ) based on initial dilution. This is conservative because the translated criterion for chronic toxicity is expressed as a four-day average. The Discharger conducted chronic toxicity tests twice per year during the previous order term. The maximum single-sample chronic toxicity result was 13.5  $TU_c$ . Applying the dilution credit of 74:1 to 13.5  $TU_c$ , the resulting toxicity is less than 1.0  $TU_c$ , which is also less than the translated chronic toxicity objective (1.0  $TU_c$ ). Therefore, there is no reasonable potential for chronic toxicity in the receiving water, and no WQBEL is required.

**e. Fecal Coliform Bacteria.** Basin Plan Table 4-2A requires total coliform effluent limitations for waters that support the shellfish harvesting beneficial use. Footnote c allows substitution with fecal coliform limits provided that doing so will not result in unacceptable adverse impacts on beneficial uses (i.e., shellfish harvesting).

**f. Sediment Quality.** Pollutants in some receiving water sediments may be present in quantities that alone or in combination are toxic to benthic communities. Efforts are underway to identify stressors causing such conditions. However, to date there is no evidence directly linking compromised sediment conditions to the discharges subject to this Order; therefore, the Regional Water Board cannot draw a conclusion about reasonable potential for these discharges to cause or contribute to exceedances of the sediment quality objectives. Nevertheless, the Discharger continues to participate in the RMP, which monitors San Francisco Bay sediment and seeks to identify stressors responsible for degraded sediment quality. Thus far, the monitoring has provided only limited information about potential stressors and sediment transport. The Regional Water Board is exploring options for obtaining additional information that may inform future analyses.

#### 4. Water Quality-Based Effluent Limitations (WQBELs)

WQBELs were developed for the pollutants determined to have reasonable potential to cause or contribute to exceedances of water quality objectives. The WQBEL calculations are based on the procedures in SIP section 1.4.

- a. **WQBEL Expression.** NPDES regulations at 40 C.F.R. section 122.45(d) require that permit limits for POTWs be expressed as average weekly and average monthly limits, unless impracticable. This Order contains MDELs instead of weekly limits because MDELs better protect against acute water quality effects and are necessary to prevent fish kills or mortality to aquatic organisms. Weekly limits could allow acute and chronic toxicity to occur over shorter periods (acute and chronic aquatic life criteria are typically expressed as one-hour and four-day averages).
  
- b. **Mixing Zones and Dilution Credits.** SIP section 1.4.2 allows mixing zones and dilution credits under certain circumstances. The discharge is pumped through a 60-inch forcemain to a 654-foot diffuser section located approximately 5,300 feet offshore at a depth of 20 feet below mean lower low water. The diffuser consists of 102 three-inch openings spaced 7 feet apart. Airfield Development Engineering Consultant conducted a dilution study on behalf of the NBSU as part of a larger study to estimate hydrodynamic impacts on San Francisco Bay by the then-proposed San Francisco International Airport runway extension, and compiled its findings in its *Preliminary Report No. 8* (December 12, 2000). The study used an average dry-weather design flow of 19 MGD and a peak wet-weather design flow of 70 MGD to calculate the initial dilution around maximum flood and ebb tides, and shortly before and after slack tide. The initial dilution ratios were estimated using the U.S. EPA-supported CORMIX model. The modeling was based on 94 diffuser ports, rather than the existing 102 ports, and estimated the initial dilution to be 74:1 (74 parts San Francisco Bay water after mixing for each one part effluent) in the immediate vicinity of the diffuser. The initial dilution estimate is likely conservative because the additional ports would be expected to increase dilution.
  
- i. **Bioaccumulative Pollutants.** For certain bioaccumulative pollutants, dilution credit is significantly restricted or denied. Specifically, these pollutants include dioxin and furan compounds, which appear on the CWA section 303(d) list for Lower San Francisco Bay because, based on available data on the concentrations of these pollutants in aquatic organisms, sediment, and the water column, they impair beneficial uses. The following factors suggest insufficient assimilative capacity in San Francisco Bay for these pollutants.

Tissue samples taken from San Francisco Bay fish show the presence of these pollutants at concentrations greater than screening levels (*Contaminant Concentrations in Fish from San Francisco Bay*, May 1997). The results of a 1994 San Francisco Bay pilot study, presented in *Contaminated Levels in Fish Tissue from San Francisco Bay* (Regional Water Board, 1994) also show elevated levels of chemical contaminants in fish tissues. The Office of Environmental Health and Hazard Assessment completed a preliminary review of the data in the 1994 report and in December 1994 issued an interim consumption advisory covering certain fish species in San Francisco Bay due to the levels of some of these pollutants. The Office of Environmental Health and Hazard Assessment updated this advisory in a May 2011 report, *Health Advisory and Safe Eating Guidelines for San Francisco Bay Fish and Shellfish*, which still suggests insufficient assimilative capacity in San Francisco Bay for 303(d)-listed pollutants. Therefore, dilution credits are denied for bioaccumulative pollutants on the 303(d) list for which data are lacking on sources and significant uncertainty exists about how different sources contribute to bioaccumulation.

- ii. Non-Bioaccumulative Pollutants (except ammonia and chronic toxicity).** For non-bioaccumulative pollutants (except ammonia and chronic toxicity), a conservative dilution credit of 10:1 ( $D = 9$ ) has been assigned. The 10:1 dilution credit is based, in part, on Basin Plan Prohibition 1 (Table 4-1), which prohibits discharges with less than 10:1 dilution. SIP section 1.4.2 allows for limiting the dilution credit. The dilution credit is limited for the following reasons:
- (a) San Francisco Bay is a complex estuarine system with highly variable and seasonal upstream freshwater inflows and diurnal tidal saltwater inputs. SIP section 1.4.3 allows background conditions to be determined on a discharge-by-discharge or water-body-by-water-body basis. A water-body-by-water-body approach is taken here due to inherent uncertainties in characterizing ambient background conditions in a complex estuarine system on a discharge-by-discharge basis.
  - (b) Because of the complex hydrology of San Francisco Bay, there are uncertainties in accurately determining an appropriate mixing zone. The models used to predict dilution do not consider the three-dimensional nature of San Francisco Bay currents resulting from the interaction of tidal flushes and seasonal fresh water outflows. Being heavier and colder than fresh water, ocean salt water enters San Francisco Bay on a twice-daily tidal cycle, generally beneath the warmer fresh water that flows seaward. When these waters mix and interact, complex circulation patterns occur due to the varying densities of the fresh and ocean waters. The complex patterns occur throughout San Francisco Bay, but are most prevalent in San Pablo Bay, Carquinez Strait, and Suisun Bay. The locations of this mixing and interaction change depending on the strength of each tide. Additionally, sediment loads from the Central Valley change on a long-term basis, affecting the depth of different parts of San Francisco Bay, resulting in alteration of flow patterns, mixing, and dilution at the outfall.
- iii. Ammonia.** For ammonia, a conservative estimate of actual initial dilution was used to calculate the effluent limitations. This is justified because ammonia, a non-persistent pollutant, quickly disperses and degrades to a non-toxic state, and cumulative toxicity is unlikely. This Order uses the 74:1 dilution ratio ( $D = 73$ ) to calculate WQBELs based on the acute and chronic water quality objectives.
- iv. Chronic Toxicity.** For chronic toxicity, this Order uses an instantaneous estimate of initial dilution (74:1) to evaluate reasonable potential. This is conservative because the translated chronic toxicity criterion of 1.0  $TU_c$  is expressed as a four-day average.
- c. WQBEL Calculations.** The following table shows the WQBEL calculations. The copper and cyanide WQBELs are calculated as required by SIP section 1.4. This same methodology is used as guidance to calculate the dioxin-TEQ and ammonia WQBELs.

**Table F-8. WQBEL Calculations**

Pollutant	Copper	Cyanide	Dioxin TEQ	Total Ammonia (acute)	Total Ammonia (chronic)
Units	µg/L	µg/L	µg/L	mg/L as N	mg/L as N
Basis and Criteria type	Basin Plan Site-Specific Objective	Basin Plan Site-Specific Objective	CTR HH	Basin Plan Aquatic Life	Basin Plan Aquatic Life
Criteria -Acute	3.9	---	---	11	---
Criteria -Chronic	2.5	---	---	---	0.94
Site-Specific Objective Criteria - Acute	9.4	9.4	---	---	---
Site-Specific Objective Criteria - Chronic	6.0	2.9	---	---	---
Water Effects ratio (WER)	2.4	1	1	1	1
Lowest water quality objective (WQO)	6.0	2.9	1.4E-08	11	0.94
Site-Specific Translator – MDEL	0.87	---	---	---	---
Site-Specific Translator - AMEL	0.73	---	---	---	---
Dilution Factor (D)	9	9	0	73	73
No. of samples per month	4	4	4	4	30
Aquatic life criteria analysis required? (Y/N)	Y	Y	N	Y	Y
HH criteria analysis required? (Y/N)	N	Y	Y	N	N
Applicable Acute WQO	11	9.4	---	11	---
Applicable Chronic WQO	8.2	2.9	---	---	0.94
HH criteria	---	220,000	1.4E-08	---	---
Background (Maximum Conc for Aquatic Life calc)	2.5	0.52	---	0.19	0.10
Background (Average Conc for Human Health calc)	---	0.42	1.6E-08	---	---
Is the pollutant on the 303d list and/or bioaccumulative (Y/N)?	N	N	Y	N	N
ECA acute	85	89	---	800	---
ECA chronic	60	24	---	---	62
ECA HH	---	2,200,000	1.4E-08	---	---
No. of data points <10 or at least 80% of data reported non detect? (Y/N)	N	N	Y	N	N
Avg of effluent data points	7.2	1.7	---	23	23
Std Dev of effluent data points	2.8	1.2	---	8.3	8.3
CV calculated	0.39	0.71	N/A	0.36	0.36

Pollutant	Copper	Cyanide	Dioxin TEQ	Total Ammonia (acute)	Total Ammonia (chronic)
Units	µg/L	µg/L	µg/L	mg/L as N	mg/L as N
CV (Selected) – Final	0.39	0.71	0.60	0.36	0.36
ECA acute mult99	0.44	0.28	---	0.47	---
ECA chronic mult99	0.65	0.48	---	---	0.96
LTA acute	38	25	---	380	---
LTA chronic	39	12	---	---	60
minimum of LTAs	38	12	---	380	60
AMEL mult95	1.4	1.7	1.6	1.3	1.1
MDEL mult99	2.2	3.6	3.1	2.1	2.1
AMEL (aquatic life)	51	19	---	500	66
MDEL(aquatic life)	85	42	---	800	130
MDEL/AMEL Multiplier	1.7	2.2	2.0	1.6	1.9
AMEL (human health)	---	2,200,000	1.4E-08	---	---
MDEL (human health)	---	4,800,000	2.8E-08	---	---
minimum of AMEL for Aq. life vs HH	51	19	1.4E-08	500	66
minimum of MDEL for Aq. Life vs HH	85	42	2.8E-08	800	130
Previous order limit - AMEL	52	17	1.4E-08	67	67
Previous order limit - MDEL	81	44	2.8E-08	130	130
<b>Final limit - AMEL</b>	<b>51</b>	<b>17</b>	<b>1.4E-08</b>	<b>66</b>	<b>66</b>
<b>Final limit - MDEL</b>	<b>81</b>	<b>42</b>	<b>2.8E-08</b>	<b>130</b>	<b>130</b>

- d. Acute Toxicity.** This Order includes acute toxicity effluent limitations based on Basin Plan Table 4-3. Based on Basin Plan section 3.3.20, if the Discharger can demonstrate that ammonia causes acute toxicity in excess of the acute toxicity limitations in this Order, and that the ammonia in the discharge complies with the ammonia effluent limitations in this Order, then such toxicity does not constitute a violation of the effluent limitations for whole effluent acute toxicity.
- e. Fecal Coliform Bacteria.** Basin Plan Table 4-2A requires limitations for total coliform bacteria for discharges to receiving waters with the shellfish harvesting beneficial use. Basin Plan Table 4-2A, footnote c, allows substituting total coliform bacteria limitations with fecal coliform bacteria limitations provided that it can be conclusively demonstrated that the substitution will not result in unacceptable adverse impacts on the beneficial uses.

Shellfish beds may be present along the shoreline. However, the NBSU outfall is located approximately 5,300 feet offshore and discharges effluent via a deepwater diffuser. The discharge achieves a minimum dilution ratio of 74:1 in the immediate vicinity of the

diffuser and a minimum dilution ratio of 77:1 at a distance of about 165 feet from the diffuser. Due to the outfall's distance from the shoreline, the buoyant nature of the discharge, and the initial dilution modeled, the discharge will not impact shoreline fecal coliform densities. This is because compliance with fecal coliform effluent limits in this Order would result in fecal coliform densities well below the water quality objectives required for protecting shellfish harvesting at a dilution ratio of 74:1. Therefore, the fecal coliform effluent limitations are retained from the previous order.

#### D. Discharge Requirement Considerations

- 1. Antidegradation.** This Order complies with the antidegradation provisions of 40 C.F.R. section 131.12 and State Water Board Resolution 68-16. It continues the status quo with respect to the level of discharge authorized in the previous order, which is the baseline by which to measure whether degradation will occur. This Order does not allow for a reduced level of treatment or increase effluent limitations relative to the previous order.
- 2. Anti-backsliding.** This Order complies with the anti-backsliding provisions of CWA sections 402(o) and 303(d)(4) and 40 C.F.R. section 122.44(1), which generally require effluent limitations in a reissued permit to be as stringent as those in the previous permit. The requirements of this Order are at least as stringent as those in the previous order. The previous order contained effluent limitations for bis(2-ethylhexyl)phthalate; however, the reasonable potential analysis shows that the discharge no longer demonstrates reasonable potential for this pollutant to cause or contribute to exceedances of the applicable water quality objectives. This Order, therefore, does not retain these limitations. Elimination of these limitations is consistent with State Water Board Order No. WQ 2001-16.
- 3. Stringency of Requirements for Individual Pollutants.** This Order contains both technology-based and WQBELs for individual pollutants. The technology-based requirements implement minimum, applicable federal technology-based requirements. In addition, this Order contains more stringent effluent limitations as necessary to meet water quality standards. Collectively, this Order's restrictions on individual pollutants are no more stringent than required to implement CWA requirements.

This Order's WQBELs have been derived to implement water quality objectives that protect beneficial uses. The beneficial uses and water quality objectives have been approved pursuant to federal law and are the applicable federal water quality standards. To the extent that WQBELs were derived from the CTR, the CTR is the applicable standard pursuant to 40 C.F.R. section 131.38. The procedures for calculating these WQBELs are based on the CTR, as implemented in accordance with the SIP, which U.S. EPA approved on May 18, 2000. U.S. EPA approved most Basin Plan beneficial uses and water quality objectives prior to May 30, 2000. Beneficial uses and water quality objectives submitted to U.S. EPA prior to May 30, 2000, but not approved by U.S. EPA before that date, are nonetheless "applicable water quality standards for purposes of the CWA" pursuant to 40 C.F.R. section 131.21(c)(1). U.S. EPA approved the remaining beneficial uses and water quality objectives so they are applicable water quality standards pursuant to 40 C.F.R. section 131.21(c)(2).

## **V. RATIONALE FOR RECEIVING WATER LIMITATIONS**

The receiving water limitations in sections V.A and V.B of the Order are based on Basin Plan narrative and numeric water quality objectives. The receiving water limitation in section V.C of the Order requires compliance with federal and State water quality standards in accordance with the CWA and regulations adopted thereunder.

## **VI. RATIONALE FOR PROVISIONS**

### **A. Standard Provisions**

Attachment D contains standard provisions that apply to all NPDES permits in accordance with 40 C.F.R. section 122.41 and additional conditions applicable to specific categories of permits in accordance with 40 C.F.R. section 122.42. The Discharger must comply with these provisions. The conditions set forth in 40 C.F.R. sections 122.41(a)(1) and (b) through (n) apply to all state-issued NPDES permits and must be incorporated into permits either expressly or by reference.

In accordance with 40 C.F.R. section 123.25(a)(12), states may omit or modify conditions to impose more stringent requirements. Attachment G contains standard provisions that supplement the federal standard provisions in Attachment D. This Order omits the federal conditions that address enforcement authority specified in 40 C.F.R. sections 122.41(j)(5) and (k)(2) because the State's enforcement authority under the Water Code is more stringent. In lieu of these conditions, this Order incorporates Water Code section 13387(e) by reference.

### **B. Monitoring and Reporting**

CWA section 308 and 40 C.F.R. sections 122.41(h), 122.41(j)-(l), 122.44(i), and 122.48 require that NPDES permits specify monitoring and reporting requirements. Water Code sections 13267 and 13383 also authorize the Regional Water Board to establish monitoring, inspection, entry, reporting, and recordkeeping requirements. The MRP establishes monitoring, reporting, and recordkeeping requirements that implement federal and State requirements. For more background regarding these requirements, see Fact Sheet section VII. Regional Water Board Order No. R2-2016-0008 allows the Discharger to opt into certain alternative monitoring requirements.

### **C. Special Provisions**

#### **1. Reopener Provisions**

These provisions are based on 40 C.F.R. sections 122.62 and 122.63 and allow modification of this Order and its effluent limitations as necessary in response to updated water quality objectives, regulations, or other new and relevant information that may become available in the future, and other circumstances as allowed by law.

#### **2. Effluent Characterization Study and Report**

This Order does not include effluent limitations for priority pollutants that do not demonstrate reasonable potential, but this provision requires the Discharger to continue monitoring for these pollutants as described in the MRP and Attachment G. Monitoring data are necessary to verify that the “no” and “unknown” reasonable potential analysis

conclusions of this Order remain valid. This requirement is authorized pursuant to Water Code section 13267 and is necessary to inform the next permit reissuance and to ensure that the Discharger takes timely steps in response to any unanticipated change in effluent quality during the term of this Order.

### 3. Pollutant Minimization Program.

This provision is based on Basin Plan section 4.13.2 and SIP section 2.4.5.

### 4. Special Provisions for Publicly-Owned Treatment Works (POTWs)

- a. **Pretreatment Program.** This provision is based on 40 C.F.R. part 403. The Discharger implements a pretreatment program because the facility design flow is greater than 5 MGD. This provision lists the Discharger's responsibilities regarding its pretreatment program and requires compliance with the provisions in Attachment H, "Pretreatment Requirements."
- b. **Sludge and Biosolids Management.** This provision is based on Basin Plan section 4.17. "Sludge" refers to the solid, semisolid, and liquid residue removed during primary, secondary, and advanced wastewater treatment processes. "Biosolids" refers to sludge that has been treated and may be beneficially reused.
- c. **Collection System Management.** The Discharger's collection system is part of the Facility regulated through this Order. This provision requires compliance with State Water Board Order No. 2006-0003-DWQ, Statewide General Waste Discharge Requirements for Sanitary Sewer Systems, as amended by State Water Board Order No. WQ 2013-0058-EXEC and any subsequent order updating these requirements. These State Water Board WDRs require public agencies that own or operate sanitary sewer systems with one or more miles of sewer lines to enroll for coverage and comply with requirements to develop sanitary sewer management plans and report sanitary sewer overflows, among other provisions and prohibitions. The State Water Board WDRs contain requirements for operation and maintenance of collection systems and for reporting and mitigating sanitary sewer overflows that are more extensive and, therefore, more stringent than the standard provisions in Attachments D and G. Compliance with the State Water Board WDRs will satisfy the corresponding requirements in Attachments D and G.

### 5. Other Special Provisions

- a. **Specific Tasks to Reduce Wet Weather Bypasses.** Consistent with Attachment D section I.G. and 40 C.F.R. section 122.41(m), the Discharger submitted a No Feasible Alternatives Analysis (Utility Analysis) with its permit reissuance application to determine whether any feasible alternatives are available to reduce wet weather bypasses (see Fact Sheet § IV.A.3). The analysis indicated that it is infeasible to expand the Plant capacity. In September 2011, the Discharger added a 1.6-MG stormwater retention basin to the Facility, but due to space constraints, further Plant improvements are cost-prohibitive, particularly in light of the infrequency of wet weather bypasses. Instead, wet weather bypasses will be minimized by focusing on collection system improvements to reduce inflow and infiltration.



This Order requires the Discharger to continue to implement and update, as necessary, its Wet Weather Improvement Plan and report on the effectiveness of its private sewer lateral programs. It also requires the Discharger to clean and assess the condition of its collection system, continue capital spending on sewer pipe rehabilitation, and report on the status of satellite collection system agencies' capital improvement activities. The analysis and reporting requirements are based in part on U.S. EPA's proposed *Peak Wet Weather Policy* (December 2005) as guidance.

- b. Copper Action Plan.** This provision is based on Basin Plan section 7.2.1.2 and is necessary to ensure that use of copper site-specific objectives is consistent with antidegradation policies. The Discharger submitted an updated inventory of potential copper sources with its annual pollution minimization program report on February 27, 2018. This Order requires the Discharger to implement pretreatment, source control, and pollution prevention for identified sources. Additional actions may be necessary depending on the three-year rolling mean copper concentration in Central or Lower San Francisco Bay (north of Hayward Shoals). Data the San Francisco Estuary Institute compiled for 2011-2015 indicate no degradation of San Francisco Bay water quality with respect to copper (<http://www.sfei.org/pages/copper-site-specific-objective-3-year-rolling-averages-0>).
- c. Cyanide Action Plan.** This provision is based on Basin Plan section 4.7.2.2 and is necessary to ensure that use of cyanide site-specific objectives is consistent with antidegradation policies. The threshold for considering influent cyanide concentrations to indicate a possible "significant cyanide discharge" in the Discharger's service area is set at 16 µg/L. This threshold is retained from the previous order, which is about twice the maximum cyanide concentration (8.4 µg/L) found in the treatment plant influent during the previous two order terms. Because the Discharger has observed no influent cyanide concentrations greater than 8.4 µg/L, if influent concentrations twice this level were observed, there could be a significant cyanide source.
- d. Anaerobically-Digestible Material.** Standard Operating Procedures are required for dischargers that accept hauled waste food, fats, oil, and grease for injection into anaerobic digesters. The development and implementation of Standard Operating Procedures for management of these materials is intended to allow the California Department of Resources Recycling and Recovery to exempt operations from separate and redundant permitting programs. If the Discharger does not accept fats, oil, and grease for resource recovery purposes, it is not required to develop and implement Standard Operating Procedures.

Some POTWs choose to accept organic material, such as waste food, fats, oils, and grease, into their anaerobic digesters to increase production of methane and other biogases for energy production and to prevent such materials from being discharged into the collection system and potentially causing sanitary sewer overflows. The California Department of Resources Recycling and Recovery has proposed to exclude POTWs from Process Facility/Transfer Station permit requirements when the same activities are regulated under waste discharge requirements or NPDES permits. The proposed exclusion is restricted to anaerobically digestible materials that have been prescreened, slurried, processed, and conveyed in a closed system for co-digestion with regular sewage

sludge. The exclusion assumes that the facility has developed Standard Operating Procedures for proper handling, processing, tracking, and management.

- e. **Dilution Study.** This provision is based on SIP section 1.4.2 and is intended to re-evaluate the initial dilution (i.e., the near-instantaneous mixing of discharge with receiving water due to buoyancy and momentum) at Discharge Point No. 002. The study will reflect the existing outfall configuration and ensure that authorized dilution credits meet SIP requirements.

## VII. RATIONALE FOR MONITORING AND REPORTING PROGRAM (MRP)

Attachment E contains the MRP for this Order. It specifies sampling locations, pollutants to be monitored (including all parameters for which effluent limitations are specified), monitoring frequencies, and reporting requirements. The following provides the rationale for these requirements:

### A. Monitoring Requirements Rationale

1. **Influent Monitoring.** Influent flow monitoring is necessary to understand Facility operations and to evaluate compliance with Prohibition III.D, which prohibits average dry weather influent flow greater than 5.5 MGD. Influent BOD<sub>5</sub> and TSS monitoring is necessary to evaluate compliance with this Order's 85 percent removal requirements. Basin Plan section 4.7.2.2 requires cyanide monitoring because this Order is based on site-specific cyanide water quality objectives.
2. **Effluent Monitoring.** Effluent flow monitoring is necessary to understand Facility operations. Monitoring for other parameters is necessary to evaluate compliance with this Order's effluent limitations and to conduct future reasonable potential analyses. Monitoring during wet weather bypasses of biological treatment (blending) is to be reported separately from routine monitoring results so the data can be distinguished.
3. **Toxicity Testing.** Acute and chronic toxicity tests are necessary to evaluate compliance with this Order's effluent limitations and to conduct future reasonable potential analyses. Chronic toxicity tests are also necessary to evaluate whether chronic toxicity exceeds the trigger for accelerated monitoring and Toxicity Reduction Evaluations based on Basin Plan sections 4.5.5.3.2 and 4.5.5.3.3 and Basin Plan Table 4-5.

Because the Discharger elected to participate in the *Alternate Monitoring and Reporting Requirements for Municipal Wastewater Dischargers for the Purpose of Adding Support to the San Francisco Bay Regional Monitoring Program* (Order No. R2-2016-0008) and there was no significant change in the nature of the effluent, the Discharger did not conduct a chronic toxicity screening phase study for this permit reissuance. The MRP specifies that the water flea (*Ceriodaphnia dubia*) is to be used for chronic toxicity testing based on the Discharger's January 2009, chronic toxicity screening phase study and the previous order.

4. **Receiving Water Monitoring.** RMP participation is necessary to characterize the receiving water and the effects of the discharge has on it. The RMP involves collecting data on pollutants and toxicity in San Francisco Bay water, sediment, and biota.

**5. Pretreatment and Biosolids Monitoring.** The pretreatment and biosolids monitoring requirements for influent, effluent, and biosolids are necessary to evaluate compliance with the Discharger’s pretreatment program.

**6. Other Monitoring Requirements.** Pursuant to CWA section 308, U.S. EPA requires dischargers to participate in a Discharge Monitoring Report-Quality Assurance (DMR-QA) Study Program. The program annually evaluates the analytical abilities of laboratories that perform or support NPDES permit-required monitoring. The program applies to discharger laboratories and contract laboratories. There are two options to comply: (1) dischargers can obtain and analyze DMR-QA samples, or (2) pursuant to a waiver U.S. EPA issued to the State Water Board, dischargers can submit results from the most recent Water Pollution Performance Evaluation Study. Dischargers must submit results annually to the State Water Board, which then forwards the results to U.S. EPA.

**B. Monitoring Requirements Summary.** The table below summarizes routine monitoring requirements. This table is for informational purposes only. The actual requirements are specified in the MRP and elsewhere in this Order.

**Table F-9. Monitoring Requirements Summary**

Parameter <sup>[1]</sup>	Influent INF-001 <sup>[2]</sup>	Effluent EFF-001 or EFF-002 <sup>[2]</sup>	Effluent EFF-001B <sup>[2]</sup>	Alternate Effluent EFF-001 or EFF-002 <sup>[2,3]</sup>	Receiving Water	Biosolids BIO-001 <sup>[2]</sup>
Flow	Continuous/D	Continuous/D	Continuous/D	Continuous/D	Support RMP	---
Volume of Partially-Treated Wastewater Discharged	---	---	1/Blending Event	---		---
Duration of Blending Event	---	---	1/Blending Event	---		---
BOD <sub>5</sub>	2/Week	2/Week	1/Year <sup>[4]</sup>	2/Week		---
TSS	2/Week	2/Week	1/Day	2/Week		---
Oil and Grease	---	1/Quarter	---	1/Quarter		---
pH	---	2/Week	1/Year <sup>[4]</sup>	2/Week		---
Chlorine, Total Residual	---	1/Hour	---	1/Hour		---
Ammonia, Total	---	1/Month	1/Year <sup>[4]</sup>	1/Month		---
Copper, Total Recoverable	1/Year	1/Month	1/Year <sup>[4]</sup>	1/Month		1/Year
Cyanide, Total	1/Month	1/Month	1/Year <sup>[4]</sup>	1/Month		1/Year
Dioxin-TEQ	---	2/Year	---	Once		---
Fecal Coliform Bacteria	---	2/Week	1/Day	2/Week		---
Enterococcus Bacteria	---	4/Year <sup>[5]</sup>	1/Day	5/Month <sup>[5]</sup>		---
Acute Toxicity	---	1/Month	---	1/Month		---
Chronic Toxicity	---	2/Year	---	2/Year		---
Priority pollutants <sup>[6]</sup>	---	1/Year	---	1/Year (except Once for VOCs, BNAs, and chlorinated pesticides)		---
VOC	Once	Once	---	Once		Once
BNA	Once	Once	---	Once		Once
Metals	1/Year	1/Year	---	1/Year		1/Year

Parameter <sup>[1]</sup>	Influent INF-001 <sup>[2]</sup>	Effluent EFF-001 or EFF-002 <sup>[2]</sup>	Effluent EFF-001B <sup>[2]</sup>	Alternate Effluent EFF-001 or EFF-002 <sup>[2,3]</sup>	Receiving Water	Biosolids BIO-001 <sup>[2]</sup>
and Other Elements						
Hexavalent Chromium	1/Year	1/Year	---	1/Year		1/Year
Mercury	1/Year	1/Year	---	1/Year		1/Year

Sampling Frequencies:

- Continuous/D = measured continuously, and recorded and reported daily
- 1/Blending Event = once per blending event
- 1/Hour = once per hour
- 1/Day = once per day
- 2/Week = twice per week
- 1/Month = once per month
- 5/Month = five times per month
- 1/Quarter = once per quarter
- 1/Year = once per year
- 2/Year = twice per year
- 4/Year = four times per year

Footnotes:

- <sup>[1]</sup> The Discharger shall also comply with the monitoring requirements in the Mercury and PCBs Watershed Permit (NPDES Permit No. CA0038849) and the Nutrients Watershed Permit (NPDES Permit No. CA0038873).
- <sup>[2]</sup> The MRP defines these sampling frequencies.
- <sup>[3]</sup> These monitoring frequencies apply only if and when the Discharger elects to participate in the Alternate MRP (Regional Water Board Order No. R2-2016-0008).
- <sup>[4]</sup> If a TSS sample collected on the same day exceeds 45 mg/L, the frequency is once per day.
- <sup>[5]</sup> The four samples are to be collected in different calendar months during the higher recreational water contact season of the year (June to October). If the enterococcus bacteria effluent limitation is exceeded, the Discharger is to conduct 5/Month accelerated sampling for at least three consecutive months. If full compliance is demonstrated after the three-month period, the Discharger may return to the 4/Year sampling frequency.
- <sup>[6]</sup> Provision VI.C.2 of the Order requires this monitoring.

**VIII. PUBLIC PARTICIPATION**

The Regional Water Board considered the issuance of WDRs that will serve as an NPDES permit for the Facility. As a step in the WDR adoption process, Regional Water Board staff developed tentative WDRs and encouraged public participation in the WDR adoption process.

**A. Notification of Interested Parties.** The Regional Water Board notified the Discharger and interested agencies and persons of its intent to prescribe WDRs for the discharge and provided an opportunity to submit written comments and recommendations. Notification was provided through the *San Mateo County Times*. The public had access to the agenda and any changes in dates and locations through the Regional Water Board’s website at <http://www.waterboards.ca.gov/sanfranciscobay>.

**B. Written Comments.** Interested persons were invited to submit written comments concerning the tentative WDRs as explained through the notification process. Comments were to be submitted either in person or by mail to the Executive Office at the Regional Water Board at 1515 Clay Street, Suite 1400, Oakland, California 94612, to the attention of Patrick Karinja.

For full staff response and Regional Water Board consideration, the written comments were due at the Regional Water Board office by **5:00 p.m. on April 30, 2018**.

**C. Public Hearing.** The Regional Water Board held a public hearing on the tentative WDRs during its regular meeting at the following date and time, and at the following location:

Date: Wednesday, June 13, 2018  
Time: 9:00 am  
Location: Elihu Harris State Office Building  
1515 Clay Street, 1<sup>st</sup> Floor Auditorium  
Oakland, CA 94612  
Contact: Patrick Karinja, (510) 622-2407, [patrick.karinja@waterboards.ca.gov](mailto:patrick.karinja@waterboards.ca.gov).

Interested persons were invited to attend. At the public hearing, the Regional Water Board heard testimony pertinent to the discharge, WDRs, and permit. For accuracy of the record, important testimony was requested to be in writing.

Dates and venues change. The Regional Water Board web address is <http://www.waterboards.ca.gov/sanfranciscobay>, where one could access the current agenda for changes in dates and locations.

**D. Reconsideration of Waste Discharge Requirements.** Any aggrieved person may petition the State Water Board to review the Regional Water Board decision regarding the final WDRs. The State Water Board must receive the petition at the following address within 30 calendar days of the Regional Water Board action:

State Water Resources Control Board  
Office of Chief Counsel  
P.O. Box 100, 1001 I Street  
Sacramento, CA 95812-0100

For instructions on how to file a petition for review, see [http://www.waterboards.ca.gov/public\\_notices/petitions/water\\_quality/wqpetition\\_instr.shtml](http://www.waterboards.ca.gov/public_notices/petitions/water_quality/wqpetition_instr.shtml).

**E. Information and Copying.** The Report of Waste Discharge, related supporting documents, and comments received are on file and may be inspected at the address above at any time between 8:00 a.m. and 5:00 p.m. (except noon to 1:00 p.m.), Monday through Friday. Copying of documents may be arranged by calling (510) 622-2300.

**F. Register of Interested Persons.** Any person interested in being placed on the mailing list for information regarding the WDRs and NPDES permit should contact the Regional Water Board, reference the Facility, and provide a name, address, and phone number.

**G. Additional Information.** Requests for additional information or questions regarding this Order should be directed to Patrick Karinja, (510) 622-2407, [patrick.karinja@waterboards.ca.gov](mailto:patrick.karinja@waterboards.ca.gov).

## **ATTACHMENT G**

### **REGIONAL STANDARD PROVISIONS, AND MONITORING AND REPORTING REQUIREMENTS (SUPPLEMENT TO ATTACHMENT D)**

November 2017

## Contents

<b>I. STANDARD PROVISIONS – PERMIT COMPLIANCE</b>	<b>G-1</b>
A. Duty to Comply	G-1
B. Need to Halt or Reduce Activity Not a Defense	G-1
C. Duty to Mitigate	G-1
1. Contingency Plan	G-1
2. Spill Prevention Plan	G-2
D. Proper Operation and Maintenance	G-2
1. Operation and Maintenance Manual	G-2
2. Wastewater Facilities Status Report	G-2
3. Proper Supervision and Operation of Publicly-Owned Treatment Works (POTWs)	G-2
E. Property Rights	G-2
F. Inspection and Entry	G-2
G. Bypass	G-2
H. Upset	G-2
I. Other	G-3
<b>II. STANDARD PROVISIONS – PERMIT ACTION</b>	<b>G-3</b>
<b>III. STANDARD PROVISIONS – MONITORING</b>	<b>G-3</b>
A. Sampling and Analyses	G-3
1. Certified Laboratories	G-3
2. Minimum Levels	G-3
3. Monitoring Frequency	G-3
B. Standard Observations	G-5
1. Receiving Water Observations	G-5
2. Wastewater Effluent Observations	G-6
3. Beach and Shoreline Observations	G-6
4. Waste Treatment and/or Disposal Facility Periphery Observations	G-6
<b>IV. STANDARD PROVISIONS – RECORDS</b>	<b>G-6</b>
A. Records to be Maintained	G-6
B. Records of Monitoring	G-7
1. Analytical Information	G-7
2. Disinfection Process	G-7
3. Wastewater Treatment Process Solids	G-7
4. Treatment Process Bypasses	G-7
5. Treatment Facility Overflows	G-8
C. Claims of Confidentiality	G-8
<b>V. STANDARD PROVISIONS – REPORTING</b>	<b>G-8</b>
A. Duty to Provide Information	G-8
B. Signatory and Certification Requirements	G-8
C. Monitoring Reports	G-8
1. Self-Monitoring Reports	G-8
D. Compliance Schedules	G-11
E. Twenty-Four Hour Reporting	G-11
1. Oil or Other Hazardous Material Spills	G-11
2. Unauthorized Municipal Wastewater Treatment Plant Discharges	G-12
F. Planned Changes	G-13
G. Anticipated Noncompliance	G-13
H. Other Noncompliance	G-13
I. Other Information	G-13

**VI. STANDARD PROVISION – ENFORCEMENT ..... G-13**  
**VII. ADDITIONAL PROVISIONS – NOTIFICATION LEVELS ..... G-13**  
**VIII. DEFINITIONS ..... G-13**



## REGIONAL STANDARD PROVISIONS, AND MONITORING AND REPORTING REQUIREMENTS

### APPLICABILITY

This document supplements the requirements of Federal Standard Provisions (Attachment D). For clarity, these provisions are arranged using to the same headings as those used in Attachment D.

#### I. STANDARD PROVISIONS - PERMIT COMPLIANCE

**A. Duty to Comply** – Not Supplemented

**B. Need to Halt or Reduce Activity Not a Defense** – Not Supplemented

**C. Duty to Mitigate** – Supplement to Attachment D, Provision I.C.

**1. Contingency Plan.** The Discharger shall maintain a Contingency Plan as prudent in accordance with current facility emergency planning. The Contingency Plan shall describe procedures to ensure that existing facilities remain in, or are rapidly returned to, operation in the event of a process failure or emergency incident, such as employee strike, strike by suppliers of chemicals or maintenance services, power outage, vandalism, earthquake, or fire. The Discharger may combine the Contingency Plan and Spill Prevention Plan (see Provision I.C.2, below) into one document. In accordance with Regional Water Board Resolution No. 74-10, discharge in violation of the permit where the Discharger has failed to develop and implement a Contingency Plan as described below may be the basis for considering the discharge a willful and negligent violation of the permit pursuant to California Water Code section 13387. The Contingency Plan shall, at a minimum, provide for the following:

- a. Sufficient personnel for continued facility operation and maintenance during employee strikes or strikes against contractors providing services;
- b. Maintenance of adequate chemicals or other supplies, and spare parts necessary for continued facility operations;
- c. Emergency standby power;
- d. Protection against vandalism;
- e. Expeditious action to repair failures of, or damage to, equipment, including any sewer lines;
- f. Reporting of spills and discharges of untreated or inadequately treated wastes, including measures taken to clean up the effects of such discharges; and
- g. Maintenance, replacement, and surveillance of physical condition of equipment and facilities, including any sewer lines.

2. **Spill Prevention Plan.** The Discharger shall maintain a Spill Prevention Plan to prevent accidental discharges and to minimize the effects of any such discharges. The Spill Prevention Plan shall do the following:
  - a. Identify the possible sources of accidental discharge, untreated or partially-treated waste bypass, and polluted drainage;
  - b. State when current facilities and procedures became operational and evaluate their effectiveness; and
  - c. Predict the effectiveness of any proposed facilities and procedures and provide an implementation schedule with interim and final dates when the proposed facilities and procedures will be constructed, implemented, or operational.

**D. Proper Operation and Maintenance – Supplement to Attachment D, Provision I.D**

1. **Operation and Maintenance Manual.** The Discharger shall maintain an Operation and Maintenance Manual to provide the plant and regulatory personnel with a source of information describing all equipment, recommended operational strategies, process control monitoring, and maintenance activities. To remain a useful and relevant document, the Operation and Maintenance Manual shall be kept updated to reflect significant changes in treatment facility equipment and operational practices. The Operation and Maintenance Manual shall be maintained in usable condition and be available for reference and use by all relevant personnel and Regional Water Board staff.
2. **Wastewater Facilities Status Report.** The Discharger shall maintain a Wastewater Facilities Status Report and regularly review, revise, or update it, as necessary. This report shall document how the Discharger operates and maintains its wastewater collection, treatment, and disposal facilities to ensure that all facilities are adequately staffed, supervised, financed, operated, maintained, repaired, and upgraded as necessary to provide adequate and reliable transport, treatment, and disposal of all wastewater from both existing and planned future wastewater sources under the Discharger's service responsibilities.
3. **Proper Supervision and Operation of Publicly-Owned Treatment Works (POTWs).** POTWs shall be supervised and operated by persons possessing certificates of appropriate grade pursuant to Title 23, section 3680, of the California Code of Regulations.

**E. Property Rights – Not Supplemented**

**F. Inspection and Entry – Not Supplemented**

**G. Bypass – Not Supplemented**

**H. Upset – Not Supplemented**

## I. Other – Addition to Attachment D

1. Neither the treatment nor the discharge of pollutants shall create pollution, contamination, or nuisance as defined by California Water Code section 13050.
2. Collection, treatment, storage, and disposal systems shall be operated in a manner that precludes public contact with wastewater. If public contact with wastewater could reasonably occur on public property, warning signs shall be posted.
3. If the Discharger submits a timely and complete Report of Waste Discharge for permit reissuance, this permit shall continue in force and effect until the permit is reissued or the Regional Water Board rescinds the permit.

## II. STANDARD PROVISIONS – PERMIT ACTION – Not Supplemented

## III. STANDARD PROVISIONS – MONITORING

### A. Sampling and Analyses – Supplement to Attachment D, Provisions III.A and III.B

1. **Certified Laboratories.** Water and waste analyses shall be performed by a laboratory certified for these analyses in accordance with California Water Code section 13176.
2. **Minimum Levels.** For the 126 priority pollutants, the Discharger should use the analytical methods listed in Table B unless the Monitoring and Reporting Program (MRP, Attachment E) requires a particular method or minimum level (ML). All monitoring instruments and equipment shall be properly calibrated and maintained to ensure accuracy of measurements.
3. **Monitoring Frequency.** The MRP specifies the minimum sampling and analysis schedule.
  - a. **Sample Collection Timing**
    - i. The Discharger shall collect influent samples on varying days selected at random and shall not include any plant recirculation or other sidestream wastes, unless otherwise stipulated in the MRP. The Executive Officer may approve an alternative influent sampling plan if it is representative of plant influent and complies with all other permit requirements.
    - ii. The Discharger shall collect effluent samples on days coincident with influent sampling, unless otherwise stipulated by the MRP. If influent sampling is not required, the Discharger shall collect effluent samples on varying days selected at random, unless otherwise stipulated in the MRP. The Executive Officer may approve an alternative effluent sampling plan if it is representative of plant discharge and in compliance with all other permit requirements.

- iii. The Discharger shall collect effluent grab samples during periods of daytime maximum peak flows (or peak flows through secondary treatment units for facilities that recycle effluent).
  - iv. Effluent sampling for conventional pollutants shall occur on at least one day of any multiple-day bioassay the MRP requires. During the course of the bioassay, on at least one day, the Discharger shall collect and retain samples of the discharge. In the event that a bioassay result does not comply with effluent limitations, the Discharger shall analyze the retained samples for pollutants that could be toxic to aquatic life and for which it has effluent limitations.
    - (a) The Discharger shall perform bioassays on final effluent samples; when chlorine is used for disinfection, bioassays shall be performed on effluent after chlorination and dechlorination; and
    - (b) The Discharger shall analyze for total ammonia nitrogen and calculate the amount of un-ionized ammonia whenever test results fail to meet effluent limitations.
- b. Conditions Triggering Accelerated Monitoring**
- i. **Average Monthly Effluent Limitation Exceedance.** If the results from two consecutive samples of a constituent monitored in a particular month exceed the average monthly effluent limitation for any parameter (or if the required sampling frequency is once per month or less and the monthly sample exceeds the average monthly effluent limitation), the Discharger shall, within 24 hours after the results are received, increase its sampling frequency to daily until the results from the additional sampling show that the parameter complies with the average monthly effluent limitation.
  - ii. **Maximum Daily Effluent Limitation Exceedance.** If a sample result exceeds a maximum daily effluent limitation, the Discharger shall, within 24 hours after the result is received, increase its sampling frequency to daily until the results from two samples collected on consecutive days show compliance with the maximum daily effluent limitation.
  - iii. **Acute Toxicity.** If final or intermediate results of an acute bioassay indicate a violation or threatened violation (e.g., the percentage of surviving test organisms of any single acute bioassay is less than 70 percent), the Discharger shall initiate a new test as soon as practical or as described in applicable State Water Board plan provisions that become effective after adoption of these Regional Standard Provisions. The Discharger shall investigate the cause of the mortalities and report its findings in the next self-monitoring report.
  - iv. **Chlorine.** The Discharger shall calibrate chlorine residual analyzers against grab samples as frequently as necessary to maintain accurate control and reliable operation. If an effluent violation is detected, the Discharger shall collect grab samples at least every 30 minutes until compliance with the limitation is achieved,

unless the Discharger monitors chlorine residual continuously. In such cases, the Discharger shall continue to conduct continuous monitoring.

- v. **Bypass.** Except as indicated below, if a Discharger bypasses any portion of its treatment facility, it shall monitor flows and collect samples at affected discharge points and analyze samples for all constituents with effluent limitations on a daily basis for the duration of the bypass. The Discharger need not accelerate chronic toxicity monitoring. The Discharger also need not collect and analyze samples for mercury, dioxin-TEQ, and PCBs after the first day of the bypass. The Discharger may satisfy the accelerated acute toxicity monitoring requirement by conducting a flow-through test or static renewal test that captures the duration of the bypass (regardless of the method specified in the MRP). If bypassing disinfection units only, the Discharger shall only monitor bacteria indicators daily.
  - (a) **Bypass for Essential Maintenance.** If a Discharger bypasses a treatment unit for essential maintenance pursuant to Attachment D section I.G.2, the Executive Officer may reduce the accelerated monitoring requirements above if the Discharger (i) monitors effluent at affected discharge points on the first day of the bypass for all constituents with effluent limitations, except chronic toxicity; and (ii) identifies and implements measures to ensure that the bypass will continue to comply with effluent limitations.
  - (b) **Approved Wet Weather Bypasses.** If a Discharger bypasses a treatment unit or permitted outfall during wet weather with Executive Officer approval pursuant to Attachment D section I.G.4, the Discharger shall monitor flows and collect and retain samples for affected discharge points on a daily basis for the duration of the bypass. The Discharger shall analyze daily for TSS using 24-hour composites (or more frequent increments) and for bacteria indicators with effluent limitations using grab samples. If TSS exceeds 45 mg/L in any composite sample, the Discharger shall also analyze daily the retained samples for all other constituents with effluent limitations, except oil and grease, mercury, PCBs, dioxin-TEQ, and acute and chronic toxicity. Additionally, at least once each year, the Discharger shall analyze the retained samples for one approved bypass for all other constituents with effluent limitations, except oil and grease, mercury, PCBs, dioxin-TEQ, and acute and chronic toxicity. This monitoring shall be in addition to the minimum monitoring specified in the MRP.

## B. Standard Observations – Addition to Attachment D

- 1. **Receiving Water Observations.** The following requirements only apply when the MRP requires standard observations of receiving waters. Standard observations shall include the following:
  - a. **Floating and Suspended Materials** (e.g., oil, grease, algae, and other macroscopic particulate matter) — presence or absence, source, and size of affected area.
  - b. **Discoloration and Turbidity** — color, source, and size of affected area.

- c. **Odor** — presence or absence, characterization, source, and distance of travel.
        - d. **Beneficial Water Use** — estimated number of water-associated waterfowl or wildlife, fisherpeople, and other recreational activities.
        - e. **Hydrographic Condition** — time and height of high and low tides (corrected to nearest National Oceanic and Atmospheric Administration location for the sampling date and time).
        - f. **Weather Conditions** — wind direction, air temperature, and total precipitation during five days prior to observation.
2. **Wastewater Effluent Observations.** The following requirements only apply when the MRP requires standard observations of wastewater effluent. Standard observations shall include the following:
  - a. **Floating and Suspended Material of Wastewater Origin** (e.g., oil, grease, algae, and other macroscopic particulate matter) — presence or absence.
  - b. **Odor** — presence or absence, characterization, source, distance of travel, and wind direction.
3. **Beach and Shoreline Observations.** The following requirements only apply when the MRP requires standard observations of beaches or shorelines. Standard observations shall include the following:
  - a. **Material of Wastewater Origin** — presence or absence, description of material, estimated size of affected area, and source.
  - b. **Beneficial Use** — estimate of number of people participating in recreational water contact, non-water contact, and fishing activities.
4. **Waste Treatment and/or Disposal Facility Periphery Observations.** The following requirements only apply when the MRP requires standard observations of the periphery of waste treatment or disposal facilities. Standard observations shall include the following:
  - a. **Odor** — presence or absence, characterization, source, and distance of travel.
  - b. **Weather Conditions** — wind direction and estimated velocity.

#### IV. STANDARD PROVISIONS – RECORDS

##### A. Records to be Maintained – Supplement to Attachment D, Provision IV.A

The Discharger shall maintain records in a manner and at a location (e.g., the wastewater treatment plant or the Discharger's offices) such that the records are accessible to Regional Water Board staff. The minimum retention period specified in Attachment D, Provision IV, shall be extended during the course of any unresolved litigation regarding permit-related discharges, or when requested by Regional Water Board or U.S. EPA, Region IX, staff.

A copy of the permit shall be maintained at the discharge facility and be available at all times to operating personnel.

**B. Records of Monitoring** – Supplement to Attachment D, Provision IV.B

Monitoring records shall include the following:

- 1. Analytical Information.** Records shall include analytical method detection limits, minimum levels, reporting levels, and related quantification parameters.
- 2. Disinfection Process.** For the disinfection process, records shall include the following:
  - a.** For bacteriological analyses:
    - i.** Wastewater flow rate at the time of sample collection; and
    - ii.** Required statistical parameters for cumulative bacterial values (e.g., moving median or geometric mean for the number of samples or sampling period identified in the MRP).
  - b.** For the chlorination process (when chlorine is used for disinfection), at least daily average values for the following:
    - i.** Chlorine residual of treated wastewater as it enters the chlorine contact basin (mg/L);
    - ii.** Chlorine dosage (kg/day); and
    - iii.** Dechlorination chemical dosage (kg/day).
- 3. Wastewater Treatment Process Solids.** For each treatment unit process that involves solids removal from the wastewater stream, records shall include the following:
  - a.** Total volume or mass of solids removed from each collection unit (e.g., grit, skimmings, undigested biosolids, or combination) for each calendar month or other time period as appropriate, but not to exceed annually; and
  - b.** Final disposition of such solids (e.g., landfill, other subsequent treatment unit).
- 4. Treatment Process Bypasses.** For all treatment process bypasses, including wet weather blending, records shall include the following:
  - a.** Chronological log of treatment process bypasses;
  - b.** Identification of treatment processes bypassed;
  - c.** Beginning and ending dates and times of bypasses;
  - d.** Bypass durations;
  - e.** Estimated bypass volumes; and

- f. Description of, or reference to other reports describing, the bypasses, their cause, the corrective actions taken (except for wet weather blending explicitly approved within the permit and in compliance with any related permit conditions), and any additional monitoring conducted.

5. **Treatment Plant Overflows.** The Discharger shall retain a chronological log of overflows at the treatment plant, including the headworks and all units and appurtenances downstream, and records supporting the information provided in accordance with Provision V.E.2, below.

**C. Claims of Confidentiality – Not Supplemented**

**V. STANDARD PROVISIONS – REPORTING**

**A. Duty to Provide Information – Not Supplemented**

**B. Signatory and Certification Requirements – Not Supplemented**

**C. Monitoring Reports – Supplement to Attachment D, Provision V.C**

1. **Self-Monitoring Reports.** For each reporting period established in the MRP, the Discharger shall submit a self-monitoring report to the Regional Water Board in accordance with the requirements listed in the MRP and below:

- a. **Transmittal Letter.** Each self-monitoring report shall be submitted with a transmittal letter that includes the following:

- i. Identification of all violations of effluent limitations or other waste discharge requirements found during the reporting period;
- ii. Details regarding the violations, such as parameters, magnitude, test results, frequency, and dates;
- iii. Causes of the violations;
- iv. Corrective actions taken or planned to resolve violations and prevent recurrences, and dates or time schedules for implementation (the Discharger may refer to previously submitted reports that address the corrective actions);
- v. Explanation for any data invalidation. Data should not be submitted in a self-monitoring report if it does not meet quality assurance/quality control standards. However, if the Discharger wishes to invalidate a measurement after submitting it in a self-monitoring report, the Discharger shall identify the measurement suspected to be invalid and state the Discharger's intent to submit, within 60 days, a formal request to invalidate the measurement. The formal request shall include the original measurement in question, the reason for invalidating the measurement, all relevant documentation that supports invalidation (e.g., laboratory sheet, log entry, test results), and a discussion of the corrective actions taken or planned (with a time



schedule for completion) to prevent recurrence of the sampling or measurement problem;

- vi. Description of blending, if any. If the Discharger blends, it shall describe the duration of blending events and certify whether the blending complied with all conditions for blending;
  - vii. Description of other bypasses, if any. If the Discharger bypasses any treatment units (other than blending), it shall describe the duration of the bypasses and effluent quality during those times; and
  - viii. Signature. The transmittal letter shall be signed in accordance with Attachment D, Provision V.B.
- b. Compliance Evaluation Summary.** Each self-monitoring report shall include a compliance evaluation summary that addresses each parameter for which the permit specifies effluent limitations, the number of samples taken during the monitoring period, and the number of samples that exceed the effluent limitations.
- c. More Frequent Monitoring.** If the Discharger monitors any pollutant more frequently than required by the MRP, the Discharger shall include the results of such monitoring in the calculation and reporting of the data submitted in the self-monitoring report.
- d. Analysis Results**
- i. **Tabulation.** Each self-monitoring report shall include tabulations of all required analyses and observations, including parameters, dates, times, sample stations, types of samples, test results, method detection limits, method minimum levels, and method reporting levels (if applicable), signed by the laboratory director or other responsible official.
  - ii. **Multiple Samples.** Unless the MRP specifies otherwise, when determining compliance with effluent limitations (other than instantaneous effluent limitations) and more than one sample result is available, the Discharger shall compute the arithmetic mean. If the data set contains one or more results that are “Detected, but Not Quantified (DNQ) or “Not Detected” (ND), the Discharger shall instead compute the median in accordance with the following procedure:
    - (a) The data set shall be ranked from low to high, reported ND determinations lowest, DNQ determinations next, followed by quantified values (if any). The order of the individual ND or DNQ determinations is unimportant.
    - (b) The median of the data set shall be determined. If the data set has an odd number of data points, the median is the middle value. If the data set has an even number of data points, the median is the average of the two values around the middle, unless one or both of these values is ND or DNQ, in which case the median shall be the lower of the two results (where DNQ is lower than a quantified value and ND is lower than DNQ).

- iii. **Duplicate Samples.** The Discharger shall report the average of duplicate sample analyses when reporting for a single sample result (or the median if one or more of the duplicates is DNQ or ND [see Provision V.C.1.c.ii, above]). For bacteria indicators, the Discharger shall report the geometric mean of the duplicate analyses.
- iv. **Dioxin-TEQ.** The Discharger shall report for each dioxin and furan congener the analytical results of effluent monitoring, including the reporting level, the method detection limit, and the measured concentration. The Discharger shall report all measured values of individual congeners, including data qualifiers. When calculating dioxin-TEQ, the Discharger shall set congener concentrations below the minimum levels (MLs) to zero. The Discharger shall calculate and report dioxin-TEQ using the following formula, where the MLs, toxicity equivalency factors (TEFs), and bioaccumulation equivalency factors (BEFs) are as provided in Table A:

$$\text{Dioxin-TEQ} = \Sigma (C_x \times \text{TEF}_x \times \text{BEF}_x)$$

where:  $C_x$  = measured or estimated concentration of congener  $x$   
 $\text{TEF}_x$  = toxicity equivalency factor for congener  $x$   
 $\text{BEF}_x$  = bioaccumulation equivalency factor for congener  $x$

**Table A**  
 Minimum Levels, Toxicity Equivalency Factors,  
 and Bioaccumulation Equivalency Factors

Dioxin or Furan Congener	Minimum Level (pg/L)	2005 Toxicity Equivalency Factor (TEF)	Bioaccumulation Equivalency Factor (BEF)
2,3,7,8-TCDD	10	1.0	1.0
1,2,3,7,8-PeCDD	50	1.0	0.9
1,2,3,4,7,8-HxCDD	50	0.1	0.3
1,2,3,6,7,8-HxCDD	50	0.1	0.1
1,2,3,7,8,9-HxCDD	50	0.1	0.1
1,2,3,4,6,7,8-HpCDD	50	0.01	0.05
OCDD	100	0.0003	0.01
2,3,7,8-TCDF	10	0.1	0.8
1,2,3,7,8-PeCDF	50	0.03	0.2
2,3,4,7,8-PeCDF	50	0.3	1.6
1,2,3,4,7,8-HxCDF	50	0.1	0.08
1,2,3,6,7,8-HxCDF	50	0.1	0.2
1,2,3,7,8,9-HxCDF	50	0.1	0.6
2,3,4,6,7,8-HxCDF	50	0.1	0.7
1,2,3,4,6,7,8-HpCDF	50	0.01	0.01
1,2,3,4,7,8,9-HpCDF	50	0.01	0.4
OCDF	100	0.0003	0.02

- e. **Results Not Yet Available.** The Discharger shall make all reasonable efforts to obtain analytical data for required parameter sampling in a timely manner. Certain analyses may require additional time to complete analytical processes and report results. In these cases,

the Discharger shall describe the circumstances in the self-monitoring report and include the data for these parameters and relevant discussions of any violations in the next self-monitoring report due after the results are available.

- f. Annual Self-Monitoring Reports.** By the date specified in the MRP, the Discharger shall submit an annual self-monitoring report covering the previous calendar year. The report shall contain the following:
- i.** Comprehensive discussion of treatment plant performance, including documentation of any blending or other bypass events, and compliance with the permit. This discussion shall include any corrective actions taken or planned, such as changes to facility equipment or operation practices that may be needed to achieve compliance, and any other actions taken or planned that are intended to improve the performance and reliability of wastewater collection, treatment, or disposal practices;
  - ii.** List of approved analyses, including the following:
    - (a)** List of analyses for which the Discharger is certified;
    - (b)** List of analyses performed for the Discharger by a separate certified laboratory (copies of reports signed by the laboratory director of that laboratory need not be submitted but shall be retained onsite); and
    - (c)** List of “waived” analyses, as approved;
  - iii.** Plan view drawing or map showing the Discharger’s facility, flow routing, and sampling and observation station locations; and
  - iv.** Results of facility report reviews. The Discharger shall regularly review, revise, and update, as necessary, the Operation and Maintenance Manual, Contingency Plan, Spill Prevention Plan, and Wastewater Facilities Status Report so these documents remain useful and relevant to current practices. At a minimum, reviews shall be conducted annually. The Discharger shall describe or summarize its review and evaluation procedures, recommended or planned actions, and estimated time schedule for implementing these actions. The Discharger shall complete changes to these documents to ensure that they remain up-to-date.

**D. Compliance Schedules – Not supplemented**

**E. Twenty-Four Hour Reporting – Supplement to Attachment D, Provision V.E**

**1. Oil or Other Hazardous Material Spills**

- a.** Within 24 hours of becoming aware of a spill of oil or other hazardous material not contained onsite and completely cleaned up, the Discharger shall report as follows:
  - i.** If the spill exceeds reportable quantities for hazardous materials listed in 40 C.F.R. part 302. The Discharger shall call the California Office of Emergency Services (800-852-7550).

- ii. If the spill does not exceed reportable quantities for hazardous materials listed in 40 C.F.R., part 302, the Discharger shall call the Regional Water Board (510-622-2369).
- b. The Discharger shall submit a written report to the Regional Water Board within five working days following either of the above telephone notifications unless directed otherwise by Regional Water Board staff. A report submitted electronically is acceptable. The written report shall include the following:
  - i. Date and time of spill, and duration if known;
  - ii. Location of spill (street address or description of location);
  - iii. Nature of material spilled;
  - iv. Quantity of material spilled;
  - v. Receiving water body affected, if any;
  - vi. Cause of spill;
  - vii. Estimated size of affected area;
  - viii. Observed impacts to receiving waters (e.g., oil sheen, fish kill, water discoloration);
  - ix. Corrective actions taken to contain, minimize, or clean up the spill;
  - x. Future corrective actions planned to prevent recurrence, and implementation schedule; and
  - xi. Persons or agencies notified.

## 2. Unauthorized Municipal Wastewater Treatment Plant Discharges<sup>1</sup>

- a. **Two-Hour Notification.** For any unauthorized discharge that enters a drainage channel or surface water, the Discharger shall, as soon as possible, but not later than two hours after becoming aware of the discharge, notify the California Office of Emergency Services (800-852-7550) and the local health officer or director of environmental health with jurisdiction over the affected water body. Notification shall include the following:
  - i. Incident description and cause;
  - ii. Location of threatened or involved waterways or storm drains;
  - iii. Date and time that the unauthorized discharge started;

---

<sup>1</sup> California Code of Regulations, Title 23, section 2250(b), defines an unauthorized discharge to be a discharge, not regulated by waste discharge requirements, of treated, partially-treated, or untreated wastewater resulting from the intentional or unintentional diversion of wastewater from a collection, treatment, or disposal system.

- iv. Estimated quantity and duration of the unauthorized discharge (to the extent known), and estimated amount recovered;
  - v. Level of treatment prior to discharge (e.g., raw wastewater, primary-treated wastewater, or undisinfected secondary-treated wastewater); and
  - vi. Identity of person reporting the unauthorized discharge.
- b. Five-Day Written Report.** Within five business days following the two-hour notification, the Discharger shall submit a written report that includes, in addition to the information listed in Provision V.E.2.a, above, the following:
- i. Methods used to delineate the geographical extent of the unauthorized discharge within receiving waters;
  - ii. Efforts implemented to minimize public exposure to the unauthorized discharge;
  - iii. Visual observations of the impacts (if any) noted in the receiving waters (e.g., fish kill, discoloration of receiving water) and extent of sampling if conducted;
  - iv. Corrective measures taken to minimize the impact of the unauthorized discharge;
  - v. Measures to be taken to minimize the potential for a similar unauthorized discharge in the future;
  - vi. Summary of Spill Prevention Plan or Operation and Maintenance Manual modifications to be made, if necessary, to minimize the potential for future unauthorized discharges; and
  - vii. Quantity and duration of the unauthorized discharge, and the amount recovered.

**F. Planned Changes** – Not supplemented

**G. Anticipated Noncompliance** – Not supplemented

**H. Other Noncompliance** – Not supplemented

**I. Other Information** – Not supplemented

**VI. STANDARD PROVISION – ENFORCEMENT** – Not Supplemented

**VII. ADDITIONAL PROVISIONS – NOTIFICATION LEVELS** – Not Supplemented

**VIII. DEFINITIONS** – Addition to Attachment D

More definitions can be found in Attachment A of this NPDES Permit.

### A. Arithmetic Calculations –

- 1. Geometric Mean.** The antilog of the log mean or the back-transformed mean of the logarithmically transformed variables, which is equivalent to the multiplication of the antilogarithms. The geometric mean can be calculated with either of the following equations:

$$\text{Geometric Mean} = \text{Anti log} \left( \frac{1}{N} \sum_{i=1}^N \text{Log}(C_i) \right)$$

or

$$\text{Geometric Mean} = (C_1 \times C_2 \times \dots \times C_N)^{1/N}$$

Where “N” is the number of data points for the period analyzed and “C” is the concentration for each of the “N” data points.

- 2. Mass Emission Rate.** The rate of discharge expressed in mass. The mass emission rate is obtained from the following calculation for any calendar day:

$$\text{Mass emission rate (lb/day)} = \frac{8.345}{N} \sum_{i=1}^N Q_i C_i$$

$$\text{Mass emission rate (kg/day)} = \frac{3.785}{N} \sum_{i=1}^N Q_i C_i$$

In which “N” is the number of samples analyzed in any calendar day and “Q<sub>i</sub>” and “C<sub>i</sub>” are the flow rate (MGD) and the constituent concentration (mg/L) associated with each of the “N” grab samples that may be taken in any calendar day. If a composite sample is taken, “C<sub>i</sub>” is the concentration measured in the composite sample and “Q<sub>i</sub>” is the average flow rate occurring during the period over which the samples are composited. The daily concentration of a constituent measured over any calendar day shall be determined from the flow-weighted average of the same constituent in the combined waste streams as follows:

$$C_d = \text{Average daily concentration} = \frac{1}{Q_t} \sum_{i=1}^N Q_i C_i$$

In which “N” is the number of component waste streams and “Q” and “C” are the flow rate (MGD) and the constituent concentration (mg/L) associated with each of the “N” waste streams. “Q<sub>t</sub>” is the total flow rate of the combined waste streams.

- 3. Removal Efficiency.** The ratio of pollutants removed by the treatment facilities to pollutants entering the treatment facilities (expressed as a percentage). The Discharger shall determine removal efficiencies using monthly averages (by calendar month unless otherwise specified)

of pollutant concentration of influent and effluent samples collected at about the same time and using the following equation (or its equivalent):

$$\text{Removal Efficiency (\%)} = 100 \times [1 - (\text{Effluent Concentration} / \text{Influent Concentration})]$$

- B. Blending** – the practice of bypassing biological treatment units and recombining the bypass wastewater with biologically-treated wastewater.
- C. Composite Sample** – a sample composed of individual grab samples collected manually or by an automatic sampling device on the basis of time or flow as specified in the MRP. For flow-based composites, the proportion of each grab sample included in the composite sample shall be within plus or minus five percent (+/-5%) of the representative flow of the waste stream being measured at the time of grab sample collection. Alternatively, equal volume grab samples may be individually analyzed with the flow-weighted average calculated by averaging flow-weighted ratios of each grab sample analytical result. Grab samples comprising time-based composite samples shall be collected at intervals not greater than those specified in the MRP. The quantity of each grab sample comprising a time-based composite sample shall be a set of flow proportional volumes as specified in the MRP. If a particular time-based or flow-based composite sampling protocol is not specified in the MRP, the Discharger shall determine and implement the most representative protocol.
- D. Duplicate Sample** – a second sample taken from the same source and at the same time as an initial sample (such samples are typically analyzed identically to measure analytical variability).
- E. Grab Sample** – an individual sample collected during a short period not exceeding 15 minutes. Grab samples represent only the condition that exists at the time the sample is collected.
- F. Overflow** – the intentional or unintentional spilling or forcing out of untreated or partially-treated waste from a transport system (e.g., through manholes, at pump stations, or at collection points) upstream of the treatment plant headworks or from any part of a treatment plant.
- G. Priority Pollutants** – those constituents referred to in 40 C.F.R. part 122 as promulgated in the Federal Register, Vol. 65, No. 97, Thursday, May 18, 2000, also known as the California Toxics Rule.
- H. Untreated waste** – raw wastewater.

**Table B**  
 List of Monitoring Parameters and Analytical Methods

CTR No.	Pollutant/Parameter	Analytical Method <sup>2</sup>	Minimum Levels <sup>3</sup> (µg/l)											
			GC	GCMS	LC	Color	FAA	GFAA	ICP	ICP MS	SPGFAA	HYD RIDE	CVAA	DCP
1	Antimony	204.2					10	5	50	0.5	5	0.5		1000
2	Arsenic	206.3				20		2	10	2	2	1		1000
3	Beryllium						20	0.5	2	0.5	1			1000
4	Cadmium	200 or 213					10	0.5	10	0.25	0.5			1000
5a	Chromium (III)	SM 3500												
5b	Chromium (VI)	SM 3500				10	5							1000
	Chromium (total) <sup>4</sup>	SM 3500					50	2	10	0.5	1			1000
6	Copper	200.9					25	5	10	0.5	2			1000
7	Lead	200.9					20	5	5	0.5	2			10,000
8	Mercury	1631 (note) <sup>5</sup>												
9	Nickel	249.2					50	5	20	1	5			1000
10	Selenium	200.8 or SM 3114B or C						5	10	2	5	1		1000
11	Silver	272.2					10	1	10	0.25	2			1000
12	Thallium	279.2					10	2	10	1	5			1000
13	Zinc	200 or 289					20		20	1	10			
14	Cyanide	SM 4500 CN <sup>-</sup> C or I				5								
15	Asbestos (only required for dischargers to MUN waters) <sup>6</sup>	0100.2 <sup>7</sup>												
16	2,3,7,8-TCDD and 17 congeners (Dioxin)	1613												
17	Acrolein	603	2.0	5										
18	Acrylonitrile	603	2.0	2										
19	Benzene	602	0.5	2										
33	Ethylbenzene	602	0.5	2										
39	Toluene	602	0.5	2										
20	Bromoform	601	0.5	2										
21	Carbon Tetrachloride	601	0.5	2										
22	Chlorobenzene	601	0.5	2										
23	Chlorodibromomethane	601	0.5	2										
24	Chloroethane	601	0.5	2										
25	2-Chloroethylvinyl Ether	601	1	1										
26	Chloroform	601	0.5	2										

<sup>2</sup> The suggested method is the U.S. EPA Method unless otherwise specified (SM = Standard Methods). The Discharger may use another U.S. EPA-approved or recognized method if that method has a level of quantification below the applicable water quality objective.

Where no method is suggested, the Discharger has the discretion to use any standard method.

<sup>3</sup> Minimum levels are from the *State Implementation Policy*. They are the concentration of the lowest calibration standard for that technique based on a survey of contract laboratories. Laboratory techniques are defined as follows: GC = Gas Chromatography; GCMS = Gas Chromatography/Mass Spectrometry; LC = High Pressure Liquid Chromatography; Color = Colorimetric; FAA = Flame Atomic Absorption; GFAA = Graphite Furnace Atomic Absorption; ICP = Inductively Coupled Plasma; ICPMS = Inductively Coupled Plasma/Mass Spectrometry; SPGFAA = Stabilized Platform Graphite Furnace Atomic Absorption (i.e., U.S. EPA 200.9); Hydride = Gaseous Hydride Atomic Absorption; CVAA = Cold Vapor Atomic Absorption; DCP = Direct Current Plasma.

<sup>4</sup> Analysis for total chromium may be substituted for analysis of chromium (III) and chromium (VI) if the concentration measured is below the lowest hexavalent chromium criterion (11 µg/l).

<sup>5</sup> The Discharger shall use ultra-clean sampling (U.S. EPA Method 1669) and ultra-clean analytical methods (U.S. EPA Method 1631) for mercury monitoring. The minimum level for mercury is 2 ng/l (or 0.002 µg/l).

<sup>6</sup> MUN = Municipal and Domestic Supply. This designation, if applicable, is in the Findings of the permit.

<sup>7</sup> Determination of Asbestos Structures over 10 [micrometers] in Length in Drinking Water Using MCE Filters, U.S. EPA 600/R-94-134, June 1994.



CTR No.	Pollutant/Parameter	Analytical Method <sup>2</sup>	Minimum Levels <sup>3</sup> (µg/l)											
			GC	GCMS	LC	Color	FAA	GFAA	ICP	ICP MS	SPGFAA	HYD RIDE	CVAA	DCP
75	1,2-Dichlorobenzene	601	0.5	2										
76	1,3-Dichlorobenzene	601	0.5	2										
77	1,4-Dichlorobenzene	601	0.5	2										
27	Dichlorobromomethane	601	0.5	2										
28	1,1-Dichloroethane	601	0.5	1										
29	1,2-Dichloroethane	601	0.5	2										
30	1,1-Dichloroethylene or 1,1-Dichloroethene	601	0.5	2										
31	1,2-Dichloropropane	601	0.5	1										
32	1,3-Dichloropropylene or 1,3-Dichloropropene	601	0.5	2										
34	Methyl Bromide or Bromomethane	601	1.0	2										
35	Methyl Chloride or Chloromethane	601	0.5	2										
36	Methylene Chloride or Dichloromethane	601	0.5	2										
37	1,1,2,2-Tetrachloroethane	601	0.5	1										
38	Tetrachloroethylene	601	0.5	2										
40	1,2-Trans-Dichloroethylene	601	0.5	1										
41	1,1,1-Trichloroethane	601	0.5	2										
42	1,1,2-Trichloroethane	601	0.5	2										
43	Trichloroethene	601	0.5	2										
44	Vinyl Chloride	601	0.5	2										
45	2-Chlorophenol	604	2	5										
46	2,4-Dichlorophenol	604	1	5										
47	2,4-Dimethylphenol	604	1	2										
48	2-Methyl-4,6-Dinitrophenol or Dinitro-2-methylphenol	604	10	5										
49	2,4-Dinitrophenol	604	5	5										
50	2-Nitrophenol	604		10										
51	4-Nitrophenol	604	5	10										
52	3-Methyl-4-Chlorophenol	604	5	1										
53	Pentachlorophenol	604	1	5										
54	Phenol	604	1	1		50								
55	2,4,6-Trichlorophenol	604	10	10										
56	Acenaphthene	610 HPLC	1	1	0.5									
57	Acenaphthylene	610 HPLC		10	0.2									
58	Anthracene	610 HPLC		10	2									
60	Benzo(a)Anthracene or 1,2 Benzanthracene	610 HPLC	10	5										
61	Benzo(a)Pyrene	610 HPLC		10	2									
62	Benzo(b)Fluoranthene or 3,4 Benzofluoranthene	610 HPLC		10	10									
63	Benzo(ghi)Perylene	610 HPLC		5	0.1									
64	Benzo(k)Fluoranthene	610 HPLC		10	2									
74	Dibenzo(a,h)Anthracene	610 HPLC		10	0.1									
86	Fluoranthene	610 HPLC	10	1	0.05									
87	Fluorene	610 HPLC		10	0.1									
92	Indeno(1,2,3-cd) Pyrene	610 HPLC		10	0.05									
100	Pyrene	610 HPLC		10	0.05									
68	Bis(2-Ethylhexyl)Phthalate	606 or 625	10	5										
70	Butylbenzyl Phthalate	606 or 625	10	10										
79	Diethyl Phthalate	606 or 625	10	2										

CTR No.	Pollutant/Parameter	Analytical Method <sup>2</sup>	Minimum Levels <sup>3</sup> (µg/l)											
			GC	GCMS	LC	Color	FAA	GFAA	ICP	ICP MS	SPGFAA	HYD RIDE	CVAA	DCP
80	Dimethyl Phthalate	606 or 625	10	2										
81	Di-n-Butyl Phthalate	606 or 625		10										
84	Di-n-Octyl Phthalate	606 or 625		10										
59	Benzidine	625		5										
65	Bis(2-Chloroethoxy)Methane	625		5										
66	Bis(2-Chloroethyl)Ether	625	10	1										
67	Bis(2-Chloroisopropyl)Ether	625	10	2										
69	4-Bromophenyl Phenyl Ether	625	10	5										
71	2-Chloronaphthalene	625		10										
72	4-Chlorophenyl Phenyl Ether	625		5										
73	Chrysene	625		10	5									
78	3,3'-Dichlorobenzidine	625		5										
82	2,4-Dinitrotoluene	625	10	5										
83	2,6-Dinitrotoluene	625		5										
85	1,2-Diphenylhydrazine (note) <sup>8</sup>	625		1										
88	Hexachlorobenzene	625	5	1										
89	Hexachlorobutadiene	625	5	1										
90	Hexachlorocyclopentadiene	625	5	5										
91	Hexachloroethane	625	5	1										
93	Isophorone	625	10	1										
94	Naphthalene	625	10	1	0.2									
95	Nitrobenzene	625	10	1										
96	N-Nitrosodimethylamine	625	10	5										
97	N-Nitrosodi-n-Propylamine	625	10	5										
98	N-Nitrosodiphenylamine	625	10	1										
99	Phenanthrene	625		5	0.05									
101	1,2,4-Trichlorobenzene	625	1	5										
102	Aldrin	608	0.005											
103	α-BHC	608	0.01											
104	β-BHC	608	0.005											
105	γ-BHC (Lindane)	608	0.02											
106	δ-BHC	608	0.005											
107	Chlordane	608	0.1											
108	4,4'-DDT	608	0.01											
109	4,4'-DDE	608	0.05											
110	4,4'-DDD	608	0.05											
111	Dieldrin	608	0.01											
112	Endosulfan (alpha)	608	0.02											
113	Endosulfan (beta)	608	0.01											
114	Endosulfan Sulfate	608	0.05											
115	Endrin	608	0.01											
116	Endrin Aldehyde	608	0.01											
117	Heptachlor	608	0.01											
118	Heptachlor Epoxide	608	0.01											
119-125	PCBs: Aroclors 1016, 1221, 1232, 1242, 1248, 1254, 1260	608	0.5											
126	Toxaphene	608	0.5											

<sup>8</sup> Measurement for 1,2-Diphenylhydrazine may use azobenzene as a screen: if azobenzene is measured at >1 ug/l, then the Discharger shall analyze for 1,2-Diphenylhydrazine.

**ATTACHMENT H – PRETREATMENT REQUIREMENTS**

CALIFORNIA REGIONAL WATER QUALITY CONTROL  
BOARD  
SAN FRANCISCO BAY REGION

**ATTACHMENT H**  
**PRETREATMENT PROGRAM PROVISIONS**  
For  
**NPDES POTW WASTEWATER DISCHARGE PERMITS**

March 2011  
*(Corrected May 2011)*

TABLE OF CONTENTS	Page
I. Pretreatment Program Provisions.....	H-1
II. APPENDIX H-1.....	H-3
REQUIREMENTS FOR PRETREATMENT ANNUAL REPORTS	
A. Cover Sheet.....	H-3
B. Introduction.....	H-3
C. Definitions.....	H-4
D. Discussion of Upset, Interference and Pass Through.....	H-4
E. Influent, Effluent and Biosolids Monitoring Results.....	H-4
F. Inspection, Sampling and Enforcement Programs.....	H-4
G. Updated List of Regulated SIUs.....	H-5
H. SIU (categorical and non-categorical) Compliance Activities.....	H-6
I. Baseline Monitoring Report Update.....	H-7
J. Pretreatment Program Changes.....	H-8
K. Pretreatment Program Budget.....	H-8
L. Public Participation Summary.....	H-8
M. Biosolids Storage and Disposal Practice.....	H-9
N. Other Pollutant Reduction Activities.....	H-9
O. Other Subjects.....	H-9
P. Permit Compliance System (PCS) Data Entry Form.....	H-9
III. APPENDIX H-2.....	H-10
REQUIREMENTS FOR JANUARY-JUNE PRETREATMENT SEMIANNUAL REPORT	
A. Influent, Effluent and Biosolids Monitoring.....	H-10
B. Industrial User Compliance Status.....	H-10
C. Discharger’s Compliance with Pretreatment Program Requirements.....	H-11
IV. APPENDIX H-3.....	H-12
SIGNATURE REQUIREMENTS FOR PRETREATMENT ANNUAL AND SEMIANNUAL REPORTS	
V. APPENDIX H-4.....	H-13
REQUIREMENTS FOR INFLUENT, EFFLUENT AND BIOSOLIDS MONITORING	
A. Reduction of Monitoring Frequency.....	H-13
B. Influent and Effluent Monitoring.....	H-13
C. Biosolids Monitoring.....	H-14

## Attachment H: Pretreatment Program Provisions

- A.** The Discharger shall be responsible and liable for the performance of all Control Authority pretreatment requirements contained in 40 CFR 403, including any regulatory revisions to Part 403. Where a Part 403 revision is promulgated after the effective date of the Discharger's permit and places mandatory actions upon the Discharger as Control Authority but does not specify a timetable for completion of the actions, the Discharger shall complete the required actions within six months from the issuance date of this permit or six months from the effective date of the Part 403 revisions, whichever comes later.

(If the Discharger cannot complete the required actions within the above six-month period due to the need to process local adoption of sewer use ordinance modifications or other substantial pretreatment program modifications, the Discharger shall notify the Executive Officer in writing at least 60 days prior to the six-month deadline. The written notification shall include a summary of completed required actions, an explanation for why the six month deadline cannot be met, and a proposed timeframe to complete the rest of the required actions as soon as practical but not later than within twelve months of the issuance date of this permit or twelve months of the effective date of the Part 403 revisions, whichever comes later. The Executive Officer will notify the Discharger in writing within 30 days of receiving the request if the extension is not approved.)

The United States Environmental Protection Agency (U.S. EPA), the State and/or other appropriate parties may initiate enforcement action against a nondomestic user for noncompliance with applicable standards and requirements as provided in the Clean Water Act (Act).

- B.** The Discharger shall enforce the requirements promulgated under Sections 307(b), 307(c), 307(d) and 402(b) of the Act with timely, appropriate and effective enforcement actions. The Discharger shall cause nondomestic users subject to Federal Categorical Standards to achieve compliance no later than the date specified in those requirements or, in the case of a new nondomestic user, upon commencement of the discharge.
- C.** The Discharger shall perform the pretreatment functions as required in 40 CFR 403 and amendments or modifications thereto including, but not limited to:
1. Implement the necessary legal authorities to fully implement the pretreatment regulations as provided in 40 CFR 403.8(f)(1);
  2. Implement the programmatic functions as provided in 40 CFR 403.8(f)(2);
  3. Publish an annual list of nondomestic users in significant noncompliance as provided per 40 CFR 403.8(f)(2)(viii);
  4. Provide for the requisite funding and personnel to implement the pretreatment program as provided in 40 CFR 403.8(f)(3); and
  5. Enforce the national pretreatment standards for prohibited discharges and categorical standards as provided in 40 CFR 403.5 and 403.6, respectively.

- D.** The Discharger shall submit annually a report to U.S. EPA Region 9, the State Water Board and the Regional Water Board describing its pretreatment program activities over the previous calendar year. In the event that the Discharger is not in compliance with any conditions or requirements of the Pretreatment Program, the Discharger shall also include the reasons for noncompliance and a plan and schedule for achieving compliance. The report shall contain, but is not limited to, the information specified in Appendix H-1 entitled, “Requirements for Pretreatment Annual Reports.” The annual report is due each year on February 28.
- E.** The Discharger shall submit a pretreatment semiannual report to U.S. EPA Region 9, the State Water Board and the Regional Water Board describing the status of its significant industrial users (SIUs). The report shall contain, but is not limited to, information specified in Appendix H-2 entitled, “Requirements for Pretreatment Semiannual Reports.” The semiannual report is due July 31 for the period January through June. The information for the period July through December of each year shall be included in the Annual Report identified in Appendix H-1. The Executive Officer may exempt the Discharger from the semiannual reporting requirements on a case by case basis subject to State Water Board and U.S. EPA’s comment and approval.
- F.** The Discharger shall conduct the monitoring of its treatment plant’s influent, effluent, and sludge (biosolids) as described in Appendix H-4 entitled, “Requirements for Influent, Effluent and Sludge (Biosolids) Monitoring.” (The term “biosolids,” as used in this Attachment, shall have the same meaning as wastewater treatment plant “sludge” and will be used from this point forward.) The Discharger shall evaluate the results of the sampling and analysis during the preparation of the semiannual and annual reports to identify any trends. Signing the certification statement used to transmit the reports shall be deemed to certify the Discharger has completed this data evaluation. A tabulation of the data shall be included in the pretreatment annual report as specified in Appendix H-4. The Executive Officer may require more or less frequent monitoring on a case by case basis.

## APPENDIX H-1

### REQUIREMENTS FOR PRETREATMENT ANNUAL REPORTS

The Pretreatment Annual Report is due each year on February 28 and shall contain activities conducted during the previous calendar year. The purpose of the Annual Report is to:

- Describe the status of the Discharger's pretreatment program; and
- Report on the effectiveness of the program, as determined by comparing the results of the preceding year's program implementation.

The report shall contain, at a minimum, the following information:

#### A. Cover Sheet

The cover sheet shall include:

1. The name(s) and National Pollutant Discharge Elimination System (NPDES) permit number(s) of the Discharger(s) that is part of the Pretreatment Program;
2. The name, address and telephone number of a pretreatment contact person;
3. The period covered in the report;
4. A statement of truthfulness; and
5. The dated signature of a principal executive officer, ranking elected official, or other duly authorized employee who is responsible for overall operation of the Publicly Owned Treatment Works (POTW) (40 CFR 403.12(m)).

#### B. Introduction

This section shall include:

1. Any pertinent background information related to the Discharger and/or the nondomestic user base of the area;
2. List of applicable interagency agreements used to implement the Discharger's pretreatment program (e.g., Memoranda of Understanding (MOU) with satellite sanitary sewer collection systems); and
3. A status summary of the tasks required by a Pretreatment Compliance Inspection (PCI), Pretreatment Compliance Audit (PCA), Cleanup and Abatement Order (CAO), or other pretreatment-related enforcement actions required by the Regional Water Board or the U.S. EPA. A more detailed discussion can be referenced and included in the section entitled, "Program Changes," if needed.

### **C. Definitions**

This section shall include a list of key terms and their definitions that the Discharger uses to describe or characterize elements of its pretreatment program, or the Discharger may provide a reference to its website if the applicable definitions are available on-line.

### **D. Discussion of Upset, Interference and Pass Through**

This section shall include a discussion of Upset, Interference or Pass Through incidents, if any, at the Discharger's treatment plant(s) that the Discharger knows of or suspects were caused by nondomestic user discharges. Each incident shall be described, at a minimum, consisting of the following information:

1. A description of what occurred;
2. A description of what was done to identify the source;
3. The name and address of the nondomestic user responsible;
4. The reason(s) why the incident occurred;
5. A description of the corrective actions taken; and
6. An examination of the local and federal discharge limits and requirements for the purposes of determining whether any additional limits or changes to existing requirements may be necessary to prevent other Upset, Interference or Pass Through incidents.

### **E. Influent, Effluent and Biosolids Monitoring Results**

The Discharger shall evaluate the influent, effluent and biosolids monitoring results as specified in Appendix H-4 in preparation of this report. The Discharger shall retain the analytical laboratory reports with the Quality Assurance and Quality Control (QA/QC) data validation and make these reports available upon request.

This section shall include:

1. Description of the sampling procedures and an analysis of the results (see Appendix H-4 for specific requirements);
2. Tabular summary of the compounds detected (compounds measured above the detection limit for the analytical method used) for the monitoring data generated during the reporting year as specified in Appendix H-4;
3. Discussion of the investigation findings into any contributing sources of the compounds that exceed NPDES limits; and
4. Graphical representation of the influent and effluent metal monitoring data for the past five years with a discussion of any trends.



## **F. Inspection, Sampling and Enforcement Programs**

This section shall include at a minimum the following information:

1. Inspections: Summary of the inspection program (e.g., criteria for determining the frequency of inspections and inspection procedures);
2. Sampling Events: Summary of the sampling program (e.g., criteria for determining the frequency of sampling and chain of custody procedures); and
3. Enforcement: Summary of Enforcement Response Plan (ERP) implementation including dates for adoption, last revision and submission to the Regional Water Board.

## **G. Updated List of Regulated SIUs**

This section shall contain a list of all of the federal categories that apply to SIUs regulated by the Discharger. The specific categories shall be listed including the applicable 40 CFR subpart and section, and pretreatment standards (both maximum and average limits). Local limits developed by the Discharger shall be presented in a table including the applicability of the local limits to SIUs. If local limits do not apply uniformly to SIUs, specify the applicability in the tables listing the categorical industrial users (CIUs) and non-categorical SIUs. Tables developed in Sections 7A and 7B can be used to present or reference this information.

1. CIUs - Include a table that alphabetically lists the CIUs regulated by the Discharger as of the end of the reporting period. This list shall include:
  - a. Name;
  - b. Address;
  - c. Applicable federal category(ies);
  - d. Reference to the location where the applicable Federal Categorical Standards are presented in the report;
  - e. Identify all deletions and additions keyed to the list submitted in the previous annual report. All deletions shall be briefly explained (e.g., closure, name change, ownership change, reclassification, declassification); and
  - f. Information, calculations and data used to determine the limits for those CIUs for which a combined waste stream formula is applied.
2. Non-categorical SIUs - Include a table that alphabetically lists the SIUs not subject to any federal categorical standards that were regulated by the Discharger as of the end of the reporting period. This list shall include:
  - a. Name;

- b. Address;
- c. A brief description of the type of business;
- d. Identify all deletions and additions keyed to the list submitted in the previous annual report. All deletions shall be briefly explained (e.g., closure, name change, ownership change, reclassification, declassification); and
- e. Indicate the applicable discharge limits (e.g., different from local limits) to which the SIUs are subject and reference to the location where the applicable limits (e.g., local discharge limits) are presented in the report.

## H. SIU (categorical and non-categorical) Compliance Activities

The information required in this section may be combined in the table developed in Section 7 above.

- 1. Inspection and Sampling Summary:** This section shall contain a summary of all the SIU inspections and sampling activities conducted by the Discharger and sampling activities conducted by the SIU over the reporting year to gather information and data regarding SIU compliance. The summary shall include:
  - a. The number of inspections and sampling events conducted for each SIU by the Discharger;
  - b. The number of sampling events conducted by the SIU. Identify SIUs that are operating under an approved Total Toxic Organic Management Plan;
  - c. The quarters in which the above activities were conducted; and
  - d. The compliance status of each SIU, delineated by quarter, and characterized using all applicable descriptions as given below:
    - (1) Consistent compliance;
    - (2) Inconsistent compliance;
    - (3) Significant noncompliance;
    - (4) On a compliance schedule to achieve compliance (include the date final compliance is required);
    - (5) Not in compliance and not on a compliance schedule; and
    - (6) Compliance status unknown, and why not.
- 2. Enforcement Summary:** This section shall contain a summary of SIU compliance and enforcement activities during the reporting year. The summary may be included in the summary

table developed in section 8A and shall include the names and addresses of all SIUs affected by the actions identified below. For each notice specified in enforcement action “i” through “iv,” indicate whether it was for an infraction of a federal or local standard/limit or requirement.

- a. Warning letters or notices of violations regarding SIUs’ apparent noncompliance with or violation of any federal pretreatment categorical standards and/or requirements, or local limits and/or requirements;
  - b. Administrative Orders regarding the SIUs’ apparent noncompliance with or violation of any federal pretreatment categorical standards and/or requirements, or local limits and/or requirements;
  - c. Civil actions regarding the SIUs’ apparent noncompliance with or violation of any federal pretreatment categorical standards and/or requirements, or local limits and/or requirements;
  - d. Criminal actions regarding the SIUs’ apparent noncompliance with or violation of any federal pretreatment categorical standards and/or requirements, or local limits and/or requirements;
  - e. Assessment of monetary penalties. Identify the amount of penalty in each case and reason for assessing the penalty;
  - f. Order to restrict/suspend discharge to the Discharger; and
  - g. Order to disconnect the discharge from entering the Discharger.
- 3. July-December Semiannual Data:** For SIU violations/noncompliance during the semiannual reporting period from July 1 through December 31, provide the following information:
- a. Name and facility address of the SIU;
  - b. Indicate if the SIU is subject to Federal Categorical Standards; if so, specify the category including the subpart that applies;
  - c. For SIUs subject to Federal Categorical Standards, indicate if the violation is of a categorical or local standard;
  - d. Indicate the compliance status of the SIU for the two quarters of the reporting period; and
  - e. For violations/noncompliance identified in the reporting period, provide:
    - (1) The date(s) of violation(s);
    - (2) The parameters and corresponding concentrations exceeding the limits and the discharge limits for these parameters; and

- (3) A brief summary of the noncompliant event(s) and the steps that are being taken to achieve compliance.

### **I. Baseline Monitoring Report Update**

This section shall provide a list of CIUs added to the pretreatment program since the last annual report. This list of new CIUs shall summarize the status of the respective Baseline Monitoring Reports (BMR). The BMR must contain the information specified in 40 CFR 403.12(b). For each new CIU, the summary shall indicate when the BMR was due; when the CIU was notified by the Discharger of this requirement; when the CIU submitted the report; and/or when the report is due.

### **J. Pretreatment Program Changes**

This section shall contain a description of any significant changes in the Pretreatment Program during the past year including, but not limited to:

1. Legal authority;
2. Local limits;
3. Monitoring/ inspection program and frequency;
4. Enforcement protocol;
5. Program's administrative structure;
6. Staffing level;
7. Resource requirements;
8. Funding mechanism;
9. If the manager of the Discharger's pretreatment program changed, a revised organizational chart shall be included; and
10. If any element(s) of the program is in the process of being modified, this intention shall also be indicated.

### **K. Pretreatment Program Budget**

This section shall present the budget spent on the Pretreatment Program. The budget, either by the calendar or fiscal year, shall show the total expenses required to implement the pretreatment program. A brief discussion of the source(s) of funding shall be provided. In addition, the Discharger shall make available upon request specific details on its pretreatment program expense amounts such as for personnel, equipment, and chemical analyses.

## **L. Public Participation Summary**

This section shall include a copy of the public notice as required in 40 CFR 403.8(f)(2)(viii). If a notice was not published, the reason shall be stated.

## **M. Biosolids Storage and Disposal Practice**

This section shall describe how treated biosolids are stored and ultimately disposed. If a biosolids storage area is used, it shall be described in detail including its location, containment features and biosolids handling procedures.

## **N. Other Pollutant Reduction Activities**

This section shall include a brief description of any programs the Discharger implements to reduce pollutants from nondomestic users that are not classified as SIUs. If the Discharger submits any of this program information in an Annual Pollution Prevention Report, reference to this other report shall satisfy this reporting requirement.

## **O. Other Subjects**

Other information related to the Pretreatment Program that does not fit into any of the above categories should be included in this section.

## **P. Permit Compliance System (PCS) Data Entry Form**

The annual report shall include the PCS Data Entry Form. This form shall summarize the enforcement actions taken against SIUs in the past year. This form shall include the following information:

1. Discharger's name,
2. NPDES Permit number,
3. Period covered by the report,
4. Number of SIUs in significant noncompliance (SNC) that are on a pretreatment compliance schedule,
5. Number of notices of violation and administrative Orders issued against SIUs,
6. Number of civil and criminal judicial actions against SIUs,
7. Number of SIUs that have been published as a result of being in SNC, and
8. Number of SIUs from which penalties have been collected.

## APPENDIX H-2

### REQUIREMENTS FOR JANUARY-JUNE PRETREATMENT SEMIANNUAL REPORT

The pretreatment semiannual report is due on July 31 for pretreatment program activities conducted from January through June unless an exception has been granted by the Regional Water Board's Executive Officer (e.g., pretreatment programs without any SIUs may qualify for an exception to the pretreatment semiannual report). Pretreatment activities conducted from July through December of each year shall be included in the Pretreatment Annual Report as specified in Appendix H-1. The pretreatment semiannual report shall contain, at a minimum the following information:

#### A. Influent, Effluent and Biosolids Monitoring

The influent, effluent and biosolids monitoring results shall be evaluated in preparation of this report. The Discharger shall retain analytical laboratory reports with the QA/QC data validation and make these reports available upon request. The Discharger shall also make available upon request a description of its influent, effluent and biosolids sampling procedures. Violations of any parameter that exceed NPDES limits shall be identified and reported. The contributing source(s) of the parameters that exceed NPDES limits shall be investigated and discussed.

#### B. Significant Industrial User Compliance Status

This section shall contain a list of all SIUs that were not in consistent compliance with all pretreatment standards/limits or requirements for the reporting period. For the reported SIUs, the compliance status for the previous semiannual reporting period shall be included. Once the SIU has determined to be out of compliance, the SIU shall be included in subsequent reports until consistent compliance has been achieved. A brief description detailing the actions that the SIU undertook to come back into compliance shall be provided.

For each SIU on the list, the following information shall be provided:

1. Name and facility address of the SIU;
2. Indicate if the SIU is subject to Federal Categorical Standards; if so, specify the category including the subpart that applies;
3. For SIUs subject to Federal Categorical Standards, indicate if the violation is of a categorical or local standard;
4. Indicate the compliance status of the SIU for the two quarters of the reporting period; and
5. For violations/noncompliance identified in the reporting period, provide:
  - a. The date(s) of violation(s);
  - b. The parameters and corresponding concentrations exceeding the limits and the discharge limits for these parameters; and

- c. A brief summary of the noncompliant event(s) and the steps that are being taken to achieve compliance.

### **C. Discharger's Compliance with Pretreatment Program Requirements**

This section shall contain a discussion of the Discharger's compliance status with the Pretreatment Program Requirements as indicated in the latest Pretreatment Compliance Audit (PCA) Report or Pretreatment Compliance Inspection (PCI) Report. It shall contain a summary of the following information:

1. Date of latest PCA or PCI report;
2. Date of the Discharger's response;
3. List of unresolved issues; and
4. Plan(s) and schedule for resolving the remaining issues.

### APPENDIX H-3

#### **SIGNATURE REQUIREMENTS FOR PRETREATMENT ANNUAL AND SEMIANNUAL REPORTS**

The pretreatment annual and semiannual reports shall be signed by a principal executive officer, ranking elected official, or other duly authorized employee who is responsible for the overall operation of the Discharger (POTW - 40 CFR section 403.12[m]). Signed copies of the reports shall be submitted to the State Water Board and the Regional Water Board through the electronic self-monitoring report (eSMR) module of the California Integrated Water Quality System (CIWQS). Signed copies of the reports shall also be submitted electronically to U.S. EPA at [R9Pretreatment@epa.gov](mailto:R9Pretreatment@epa.gov) or as instructed otherwise.



## APPENDIX H-4

### REQUIREMENTS FOR INFLUENT, EFFLUENT AND BIOSOLIDS MONITORING

The Discharger shall conduct sampling of its treatment plant's influent, effluent and biosolids at the frequency shown in **the pretreatment requirements table** of the Monitoring and Reporting Program (MRP, Attachment E). When sampling periods coincide, one set of test results, reported separately, may be used for those parameters that are required to be monitored by both the influent and effluent monitoring requirements of the MRP and the Pretreatment Program. The Pretreatment Program monitoring reports as required in Appendices H-1 and H-2 shall be transmitted to the Pretreatment Program Coordinator.

#### A. Reduction of Monitoring Frequency

The minimum frequency of Pretreatment Program influent, effluent, and biosolids monitoring shall be dependent on the number of SIUs identified in the Discharger's Pretreatment Program as indicated in Table H-1.

Number of SIUs	Minimum Frequency
< 5	Once every five years
> 5 and < 50	Once every year
> 50	Twice per year

If the Discharger's required monitoring frequency is greater than the minimum specified in Table H-1, the Discharger may request a reduced monitoring frequency for that constituent(s) as part of its application for permit reissuance if it meets the following criteria:

The monitoring data for the constituent(s) consistently show non-detect (ND) levels for the effluent monitoring and very low (i.e., near ND) levels for influent and biosolids monitoring for a minimum of eight previous years' worth of data.

The Discharger's request shall include tabular summaries of the data and a description of the trends in the industrial, commercial, and residential customers in the Discharger's service area that demonstrate control over the sources of the constituent(s). The Regional Water Board may grant a reduced monitoring frequency in the reissued permit after considering the information provided by the Discharger and any other relevant information.

#### B. Influent and Effluent Monitoring

The Discharger shall monitor for the parameters using the required sampling and test methods listed in **the pretreatment table** of the MRP. Any test method substitutions must have received prior written Executive Officer approval. Influent and effluent sampling locations shall be the same as those sites specified in the MRP.

The influent and effluent samples should be taken at staggered times to account for treatment plant detention time. Appropriately staggered sampling is considered consistent with the requirement for

collection of effluent samples coincident with influent samples in Section III.A.3.a(2) of Attachment G. All samples must be representative of daily operations. Sampling and analysis shall be performed in accordance with the techniques prescribed in 40 CFR 136 and amendments thereto. For effluent monitoring, the reporting limits for the individual parameters shall be at or below the minimum levels (MLs) as stated in the Policy for Implementation of Toxics Standards for Inland Surface Waters, Enclosed Bays, and Estuaries of California (2000) [also known as the State Implementation Policy (SIP)]; any revisions to the MLs shall be adhered to. If a parameter does not have a stated ML, then the Discharger shall conduct the analysis using the lowest commercially available and reasonably achievable detection levels.

The following report elements should be used to submit the influent and effluent monitoring results. A similarly structured format may be used but will be subject to Regional Water Board approval. The monitoring reports shall be submitted with the Pretreatment Annual Report identified in Appendix H-1.

1. Sampling Procedures, Sample Dechlorination, Sample Compositing, and Data Validation (applicable quality assurance/quality control) shall be performed in accordance with the techniques prescribed in 40 CFR 136 and amendments thereto. The Discharger shall make available upon request its sampling procedures including methods of dechlorination, compositing, and data validation.
2. A tabulation of the test results for the detected parameters shall be provided.
3. Discussion of Results – The report shall include a complete discussion of the test results for the detected parameters. If any pollutants are detected in sufficient concentration to upset, interfere or pass through plant operations, the type of pollutant(s) and potential source(s) shall be noted, along with a plan of action to control, eliminate, and/or monitor the pollutant(s). Any apparent generation and/or destruction of pollutants attributable to chlorination/dechlorination sampling and analysis practices shall be noted.

### **C. Biosolids Monitoring**

Biosolids should be sampled in a manner that will be representative of the biosolids generated from the influent and effluent monitoring events except as noted in (3. below. The same parameters required for influent and effluent analysis shall be included in the biosolids analysis. The biosolids analyzed shall be a composite sample of the biosolids for final disposal consisting of:

1. Biosolids lagoons – 20 grab samples collected at representative equidistant intervals (grid pattern) and composited as a single grab, or
2. Dried stockpile – 20 grab samples collected at various representative locations and depths and composited as a single grab, or
3. Dewatered biosolids - daily composite of 4 representative grab samples each day for 5 days taken at equal intervals during the daily operating shift taken from a) the dewatering units or b) each truckload, and shall be combined into a single 5- day composite.

The U.S. EPA manual, POTW Sludge Sampling and Analysis Guidance Document, August 1989, containing detailed sampling protocols specific to biosolids is recommended as a guidance for sampling procedures. The U.S. EPA manual Analytical Methods of the National Sewage Sludge Survey, September 1990, containing detailed analytical protocols specific to biosolids, is recommended as a guidance for analytical methods.

In determining if the biosolids are a hazardous waste, the Discharger shall adhere to Article 2, “Criteria for Identifying the Characteristics of Hazardous Waste,” and Article 3, “Characteristics of Hazardous Waste,” of Title 22, California Code of Regulations, sections 66261.10 to 66261.24 and all amendments thereto.

The following report elements should be used to submit the biosolids monitoring results. A similarly structured form may be used but will be subject to Regional Water Board approval. The results shall be submitted with the Pretreatment Annual Report identified in Appendix H-1.

- Sampling Procedures and Data Validation (applicable quality assurance/quality control) shall be performed in accordance with the techniques prescribed in 40 CFR 136 and amendments thereto. The Discharger shall make available upon request its biosolids sampling procedures and data validation methods.
- Test Results – Tabulate the test results for the detected parameters and include the percent solids.
- Discussion of Results – Include a complete discussion of test results for the detected parameters. If the detected pollutant(s) is reasonably deemed to have an adverse effect on biosolids disposal, a plan of action to control, eliminate, and/or monitor the pollutant(s) and the known or potential source(s) shall be included. Any apparent generation and/or destruction of pollutants attributable to chlorination/dechlorination sampling and analysis practices shall be noted.

The Discharger shall also provide a summary table presenting any influent, effluent or biosolids monitoring data for non-priority pollutants that the Discharger believes may be causing or contributing to interference, pass through or adversely impacting biosolids quality.