

ATTACHMENT B – NOTICE OF INTENT FORM

This NOTICE OF INTENT form shall be completed and submitted to apply for authorization or reauthorization to discharge under the Groundwater General Permit, NPDES Permit CAG912002.

1. DISCHARGER INFORMATION AND CERTIFICATION

The following certification shall be signed in accordance with Attachment D section 5.2. The Discharger hereby agrees to comply with and be responsible for all conditions specified in NPDES Permit CAG912002.

I certify under penalty of law that this document and all attachments were prepared under my direction or supervision in accordance with a system designed to assure that qualified personnel properly gather and evaluate the information submitted. Based on my inquiry of the person or persons who manage the system or those persons directly responsible for gathering the information, the information submitted is, to the best of my knowledge and belief, true, accurate, and complete. I am aware that there are significant penalties for submitting false information, including the possibility of fine and imprisonment for knowing violations. (40 C.F.R. § 122.22(d).)			
Signature		Date	
Printed Name		Title	
Company/Owner Name			
Mailing Street Address	City	State	Zip Code
Owner Type (check one) <input type="checkbox"/> Public <input type="checkbox"/> Private <input type="checkbox"/> Other, specify type:		New or Previously Authorized Facility (check one) <input type="checkbox"/> New Facility <input type="checkbox"/> Previously Authorized Facility	
Facility Information			
Facility Name			
Street Address	City	State	Zip Code
Contact Person Name		Title	
Email		Phone Number	

Check here if additional owner information is attached to this form.

2. PROJECT INFORMATION

<p>Project description (must include approximate project completion date)</p>
<p>Discharge Class (please check one)</p> <p><input type="checkbox"/> Class 1: Aquifer reclamation program well discharges</p> <p><input type="checkbox"/> Class 2: Reverse osmosis concentrate from aquifer reclamation program well discharges</p> <p><input type="checkbox"/> Class 3: Groundwater requiring minimal or no treatment (10,000 gallons per day or greater)</p> <p><input type="checkbox"/> Class 4: Groundwater requiring treatment for priority pollutants (e.g. groundwater at construction sites or active or closed cleanup sites. See Attachment G for list of priority pollutants.</p>

3. UTILITY INFORMATION

SANITARY SEWER AGENCY	
<p>Is discharge to the sanitary sewer feasible?</p> <p>Please check one:</p> <p><input type="checkbox"/> Yes</p> <p><input type="checkbox"/> No (explain why):</p> <p><input type="checkbox"/> Not Applicable (explain why):</p>	
Agency Name:	Contact Person Name:
Email:	Phone Number:
STORM DRAIN AGENCY	
<p>Is discharge to the storm drain allowed?</p> <p>Please check one:</p> <p><input type="checkbox"/> Yes</p> <p><input type="checkbox"/> No (explain why)</p> <p><input type="checkbox"/> Not Applicable (explain why)</p>	
Agency Name:	Contact Person Name:
Email:	Phone Number:

4. CONTACT INFORMATION

Duly Authorized Representative: The Discharger’s duly authorized representative, on its behalf, may sign and certify permit-required documents in accordance with Attachment D section 5.2.3. This individual shall be responsible for the overall operation of the facility or facility environmental matters.			
Company/Organization			
Name		Title	
Email		Phone Number	
Design Professional Engineer Information (see section 11.4 below)			
Company/Organization			
Name		Title	
CA PE License Number		CA PE License Expiration Date	
Email		Phone Number	
Operation and Maintenance Professional Engineer Information (see section 11.4 below)			
Company/Organization			
Name		Title	
CA PE License Number		CA PE License Expiration Date	
Email		Phone Number	
Consultancy Information			
Company/Organization			
Name		Title	
Email		Phone Number	

5. BILLING INFORMATION

Company/Organization			
Billing Contact Person Name			
Email		Phone Number	
Mailing Street Address		City	State
			Zip Code

6. DISCHARGE LOCATION INFORMATION

Receiving Water Name		
Receiving Water Salinity (in parts per thousand)		
Location	Latitude ^[1]	Longitude ^[1]
Effluent (e.g., EFF-001)		
Storm Drain Entry		
Receiving Water (e.g., RSW-001)		
<p>Discharge path to Receiving Water – describe the complete path of the discharge from the effluent monitoring location to the outfall on the receiving water, including storm drain routes, streets, land features, and distances, as necessary.</p>		

1. Submit latitude and longitude coordinates in decimal degrees with 5 figures to the right of the decimal point.

Check here if monitoring location information is attached to this form.

7. TREATMENT SYSTEM INFORMATION

Groundwater Treatment Design Capacity (gpm):		
Discharge description (describe discharge and potential pollutants of concern):		
Water reclamation (if applicable, describe type of water reclamation, location, and any specific treatment)		
Discharge Frequency Please check all that apply: <input type="checkbox"/> Continuous <input type="checkbox"/> Daily <input type="checkbox"/> Intermittent <input type="checkbox"/> Emergency (explain why):		
Process Unit Information		
Unit Name	Number of units	Brief Description (e.g., filter size, capacity, layout)
Extraction well or sump pump		
Extraction well with dedicated treatment unit		
Settling tank		
Oil-water separator		
Sand filter		
Bag or cartridge filter		
Air stripper		
Adsorption units (activated carbon, organoclay, ion exchange resin)		
Ultrafilters (reverse osmosis, nanofilters)		
Chemical additive (e.g., flocculant, pH adjuster, dechlorinator)		
Other vessels (e.g., equalization tank)		
Water reclamation vessel		
Other (please specify):		

8. MONITORING DATA

For existing dischargers, summarize influent and effluent monitoring data collected during the current permit term for the applicable parameters in sections 7.1 and 7.2, below. Provide the summary dataset in an electronic spreadsheet (e.g., Microsoft Excel). If applicable, provide a separate summary dataset for each effluent monitoring location (Monitoring Location EFF-00n), starting with Monitoring Location EFF-001. **New applicants shall provide influent or groundwater monitoring data for all listed pollutants below.**

8.1. Influent or Groundwater Monitoring Data

CTR No.	Parameter	Units	Maximum Concentration	Method Detection Limit	Test Method	Number of Samples
1	Antimony	µg/L				
2	Arsenic	µg/L				
3	Beryllium	µg/L				
4	Cadmium	µg/L				
5a	Chromium (III)	µg/L				
5b	Chromium (VI)	µg/L				
6	Copper	µg/L				
7	Lead	µg/L				
8	Mercury	µg/L				
9	Nickel	µg/L				
10	Selenium	µg/L				
11	Silver	µg/L				
12	Thallium	µg/L				
13	Zinc	µg/L				
14	Cyanide	µg/L				
15	Asbestos	fibers/L				
16	2,3,7,8-TCDD (Dioxin)	µg/L				
17	Acrolein	µg/L				
18	Acrylonitrile	µg/L				
19	Benzene	µg/L				
20	Bromoform	µg/L				
21	Carbon Tetrachloride	µg/L				
22	Chlorobenzene	µg/L				
23	Chlorodibromomethane	µg/L				
24	Chloroethane	µg/L				
25	2-Chloroethylvinyl ether	µg/L				
26	Chloroform	µg/L				
27	Dichlorobromomethane	µg/L				
28	1,1-Dichloroethane	µg/L				
29	1,2-Dichloroethane	µg/L				
30	1,1-Dichloroethylene	µg/L				
31	1,2-Dichloropropane	µg/L				
32	1,3-Dichloropropylene	µg/L				
33	Ethylbenzene	µg/L				
34	Methyl Bromide	µg/L				

CTR No.	Parameter	Units	Maximum Concentration	Method Detection Limit	Test Method	Number of Samples
35	Methyl Chloride	µg/L				
36	Methylene Chloride	µg/L				
37	1,1,2,2-Tetrachloroethane	µg/L				
38	Tetrachloroethylene	µg/L				
39	Toluene	µg/L				
40	1,2-Trans-Dichloroethylene	µg/L				
41	1,1,1-Trichloroethane	µg/L				
42	1,1,2-Trichloroethane	µg/L				
43	Trichloroethylene	µg/L				
44	Vinyl Chloride	µg/L				
45	2-Chlorophenol	µg/L				
46	2,4-Dichlorophenol	µg/L				
47	2,4-Dimethylphenol	µg/L				
48	2-Methyl- 4,6-Dinitrophenol	µg/L				
49	2,4-Dinitrophenol	µg/L				
50	2-Nitrophenol	µg/L				
51	4-Nitrophenol	µg/L				
52	3-Methyl 4-Chlorophenol	µg/L				
53	Pentachlorophenol	µg/L				
54	Phenol	µg/L				
55	2,4,6-Trichlorophenol	µg/L				
56	Acenaphthene	µg/L				
57	Acenaphthylene	µg/L				
58	Anthracene	µg/L				
59	Benzidine	µg/L				
60	Benzo(a)Anthracene	µg/L				
61	Benzo(a)Pyrene	µg/L				
62	Benzo(b)Fluoranthene	µg/L				
63	Benzo(ghi)Perylene	µg/L				
64	Benzo(k)Fluoranthene	µg/L				
65	Bis(2-Chloroethoxy)Methane	µg/L				
66	Bis(2-Chloroethyl)Ether	µg/L				
67	Bis(2-Chloroisopropyl)Ether	µg/L				
68	Bis(2-Ethylhexyl)Phthalate	µg/L				
69	4-Bromophenyl Phenyl Ether	µg/L				
70	Butylbenzyl Phthalate	µg/L				
71	2-Chloronaphthalene	µg/L				
72	4-Chlorophenyl Phenyl Ether	µg/L				
73	Chrysene	µg/L				
74	Dibenzo(a,h)Anthracene	µg/L				
75	1,2-Dichlorobenzene	µg/L				
76	1,3-Dichlorobenzene	µg/L				
77	1,4-Dichlorobenzene	µg/L				
78	3,3 Dichlorobenzidine	µg/L				

CTR No.	Parameter	Units	Maximum Concentration	Method Detection Limit	Test Method	Number of Samples
79	Diethyl Phthalate	µg/L				
80	Dimethyl Phthalate	µg/L				
81	Di-n-Butyl Phthalate	µg/L				
82	2,4-Dinitrotoluene	µg/L				
83	2,6-Dinitrotoluene	µg/L				
84	Di-n-Octyl Phthalate	µg/L				
85	1,2-Diphenylhydrazine	µg/L				
86	Fluoranthene	µg/L				
87	Fluorene	µg/L				
88	Hexachlorobenzene	µg/L				
89	Hexachlorobutadiene	µg/L				
90	Hexachlorocyclopentadiene	µg/L				
91	Hexachloroethane	µg/L				
92	Indeno(1,2,3-cd)Pyrene	µg/L				
93	Isophorone	µg/L				
94	Naphthalene	µg/L				
95	Nitrobenzene	µg/L				
96	N-Nitrosodimethylamine	µg/L				
97	N-Nitrosodi-n-Propylamine	µg/L				
98	N-Nitrosodiphenylamine	µg/L				
99	Phenanthrene	µg/L				
100	Pyrene	µg/L				
101	1,2,4-Trichlorobenzene	µg/L				
102	Aldrin	µg/L				
103	alpha-BHC	µg/L				
104	beta-BHC	µg/L				
105	gamma-BHC	µg/L				
106	delta-BHC	µg/L				
107	Chlordane (303d listed)	µg/L				
108	4,4'-DDT (303d listed)	µg/L				
109	4,4'-DDE	µg/L				
110	4,4'-DDD	µg/L				
111	Dieldrin (303d listed)	µg/L				
112	alpha-Endosulfan	µg/L				
113	beta-Endosulfan	µg/L				
114	Endosulfan Sulfate	µg/L				
115	Endrin	µg/L				
116	Endrin Aldehyde	µg/L				
117	Heptachlor	µg/L				
118	Heptachlor Epoxide	µg/L				
119-125	PCBs sum (303d listed)	µg/L				
126	Toxaphene	µg/L				
	Chlorine, Total Residual	mg/L				
	Salinity	µg/L				
	Cyanide	µg/L				
	Methyl Tertiary Butyl Ether	µg/L				

CTR No.	Parameter	Units	Maximum Concentration	Method Detection Limit	Test Method	Number of Samples
	TPH as gasoline	µg/L				
	TPH as diesel	µg/L				
	TPH as motor oil	µg/L				
	PFAS, all analytes	ng/L			EPA 1633	
	Municipal Supply Pollutants ^[1]	µg/L				

Footnote:

^[1] The Discharger shall monitor for the pollutants with Primary Maximum Contaminant Levels (MCLs), except for radionuclides. The MCLs can be found in Title 22 Table 64431-A (Inorganic Chemicals) of section 64431, Table 64433.2-A (Fluoride) of section 64433.2, and Table 64444-A (Organic Chemicals) of section 64444 of the California Code of Regulations. Priority pollutant monitoring conducted in accordance with the table above may be used to satisfy this monitoring requirement.

8.2. Effluent Monitoring Data

CTR No.	Parameter	Units	Maximum Concentration	Method Detection Limit	Test Method	Number of Samples
1	Antimony	µg/L				
2	Arsenic	µg/L				
3	Beryllium	µg/L				
4	Cadmium	µg/L				
5a	Chromium (III)	µg/L				
5b	Chromium (VI)	µg/L				
6	Copper	µg/L				
7	Lead	µg/L				
8	Mercury	µg/L				
9	Nickel	µg/L				
10	Selenium	µg/L				
11	Silver	µg/L				
12	Thallium	µg/L				
13	Zinc	µg/L				
14	Cyanide	µg/L				
15	Asbestos	fibers/L				
16	2,3,7,8-TCDD (Dioxin)	µg/L				
17	Acrolein	µg/L				
18	Acrylonitrile	µg/L				
19	Benzene	µg/L				
20	Bromoform	µg/L				
21	Carbon Tetrachloride	µg/L				
22	Chlorobenzene	µg/L				
23	Chlorodibromomethane	µg/L				
24	Chloroethane	µg/L				
25	2-Chloroethylvinyl ether	µg/L				
26	Chloroform	µg/L				
27	Dichlorobromomethane	µg/L				
28	1,1-Dichloroethane	µg/L				
29	1,2-Dichloroethane	µg/L				

CTR No.	Parameter	Units	Maximum Concentration	Method Detection Limit	Test Method	Number of Samples
30	1,1-Dichloroethylene	µg/L				
31	1,2-Dichloropropane	µg/L				
32	1,3-Dichloropropylene	µg/L				
33	Ethylbenzene	µg/L				
34	Methyl Bromide	µg/L				
35	Methyl Chloride	µg/L				
36	Methylene Chloride	µg/L				
37	1,1,2,2-Tetrachloroethane	µg/L				
38	Tetrachloroethylene	µg/L				
39	Toluene	µg/L				
40	1,2-Trans-Dichloroethylene	µg/L				
41	1,1,1-Trichloroethane	µg/L				
42	1,1,2-Trichloroethane	µg/L				
43	Trichloroethylene	µg/L				
44	Vinyl Chloride	µg/L				
45	2-Chlorophenol	µg/L				
46	2,4-Dichlorophenol	µg/L				
47	2,4-Dimethylphenol	µg/L				
48	2-Methyl- 4,6-Dinitrophenol	µg/L				
49	2,4-Dinitrophenol	µg/L				
50	2-Nitrophenol	µg/L				
51	4-Nitrophenol	µg/L				
52	3-Methyl 4-Chlorophenol	µg/L				
53	Pentachlorophenol	µg/L				
54	Phenol	µg/L				
55	2,4,6-Trichlorophenol	µg/L				
56	Acenaphthene	µg/L				
57	Acenaphthylene	µg/L				
58	Anthracene	µg/L				
59	Benzidine	µg/L				
60	Benzo(a)Anthracene	µg/L				
61	Benzo(a)Pyrene	µg/L				
62	Benzo(b)Fluoranthene	µg/L				
63	Benzo(ghi)Perylene	µg/L				
64	Benzo(k)Fluoranthene	µg/L				
65	Bis(2-Chloroethoxy)Methane	µg/L				
66	Bis(2-Chloroethyl)Ether	µg/L				
67	Bis(2-Chloroisopropyl)Ether	µg/L				
68	Bis(2-Ethylhexyl)Phthalate	µg/L				
69	4-Bromophenyl Phenyl Ether	µg/L				
70	Butylbenzyl Phthalate	µg/L				
71	2-Chloronaphthalene	µg/L				
72	4-Chlorophenyl Phenyl Ether	µg/L				
73	Chrysene	µg/L				

CTR No.	Parameter	Units	Maximum Concentration	Method Detection Limit	Test Method	Number of Samples
74	Dibenzo(a,h)Anthracene	µg/L				
75	1,2-Dichlorobenzene	µg/L				
76	1,3-Dichlorobenzene	µg/L				
77	1,4-Dichlorobenzene	µg/L				
78	3,3 Dichlorobenzidine	µg/L				
79	Diethyl Phthalate	µg/L				
80	Dimethyl Phthalate	µg/L				
81	Di-n-Butyl Phthalate	µg/L				
82	2,4-Dinitrotoluene	µg/L				
83	2,6-Dinitrotoluene	µg/L				
84	Di-n-Octyl Phthalate	µg/L				
85	1,2-Diphenylhydrazine	µg/L				
86	Fluoranthene	µg/L				
87	Fluorene	µg/L				
88	Hexachlorobenzene	µg/L				
89	Hexachlorobutadiene	µg/L				
90	Hexachlorocyclopentadiene	µg/L				
91	Hexachloroethane	µg/L				
92	Indeno(1,2,3-cd)Pyrene	µg/L				
93	Isophorone	µg/L				
94	Naphthalene	µg/L				
95	Nitrobenzene	µg/L				
96	N-Nitrosodimethylamine	µg/L				
97	N-Nitrosodi-n-Propylamine	µg/L				
98	N-Nitrosodiphenylamine	µg/L				
99	Phenanthrene	µg/L				
100	Pyrene	µg/L				
101	1,2,4-Trichlorobenzene	µg/L				
102	Aldrin	µg/L				
103	alpha-BHC	µg/L				
104	beta-BHC	µg/L				
105	gamma-BHC	µg/L				
106	delta-BHC	µg/L				
107	Chlordane (303d listed)	µg/L				
108	4,4'-DDT (303d listed)	µg/L				
109	4,4'-DDE	µg/L				
110	4,4'-DDD	µg/L				
111	Dieldrin (303d listed)	µg/L				
112	alpha-Endosulfan	µg/L				
113	beta-Endosulfan	µg/L				
114	Endosulfan Sulfate	µg/L				
115	Endrin	µg/L				
116	Endrin Aldehyde	µg/L				
117	Heptachlor	µg/L				
118	Heptachlor Epoxide	µg/L				
119-125	PCBs sum (303d listed)	µg/L				

CTR No.	Parameter	Units	Maximum Concentration	Method Detection Limit	Test Method	Number of Samples
126	Toxaphene	µg/L				
	Chlorine, Total Residual	mg/L				
	Salinity	µg/L				
	Cyanide	µg/L				
	Methyl Tertiary Butyl Ether	µg/L				
	TPH as gasoline	µg/L				
	TPH as diesel	µg/L				
	TPH as motor oil	µg/L				
	PFAS, all analytes	ng/L			EPA 1633	
	Municipal Supply Pollutants ^[1]	µg/L				

Footnote:

^[1] The Discharger shall monitor for the pollutants with Primary Maximum Contaminant Levels (MCLs), except for radionuclides. The MCLs can be found in Title 22 Table 64431-A (Inorganic Chemicals) of section 64431, Table 64433.2-A (Fluoride) of section 64433.2, and Table 64444-A (Organic Chemicals) of section 64444 of the California Code of Regulations. Priority pollutant monitoring conducted in accordance with the table above may be used to satisfy this monitoring requirement.

9. CERTIFIED ENGINEERING REPORT

Attach a certified engineering report signed and stamped by the Design Professional Engineer licensed to practice in California identified in section 4 above. The Certified Engineering Report shall include a location map, discharge flow path map, process flow diagram, and contingency plan as described Provision 6.3.3 of this Order. See section 10 below for additional details of the documents required as part of the Certified Engineering Report and NOI application package.

10. APPLICATION FEE AND MAILING INSTRUCTIONS

Submit application fee by check payable to “State Water Resources Control Board” to this address:

San Francisco Bay Regional Water Quality Control Board
Attn: NPDES Wastewater Division
1515 Clay Street, Suite 1400
Oakland, CA 94612

For the current fee, see the current Water Quality Fee Schedule (https://www.waterboards.ca.gov/resources/fees/water_quality/). Discharges authorized under the Groundwater General Permit fall under one of four classes. Classes 1, 2, and 3 are “Category 3” discharges for purposes of Water Code § 2200(b)(10), and Class 4 is a “Category 1” discharge for purposes of Water Code § 2200(b)(10).

Submit this form (with signature and attachments) via email to RB2-NPDES.GW@waterboards.ca.gov or as otherwise indicated at www.waterboards.ca.gov/sanfranciscobay/water_issues/programs/general_permits.shtml.

11. INSTRUCTIONS FOR NOTICE OF INTENT FORM

These instructions explain how to complete the NOI form. Submittal of an NOI indicates the Discharger's commitment to comply with the terms of this Order.

- 11.1. Discharger Information and Certification.** Enter the required information regarding the Discharger (i.e., the party responsible for the discharge) and certify the NOI. The person certifying the NOI must meet the requirements described in Attachment D section 5.2.2. Review these requirements carefully. Specific requirements apply to corporations, partnerships, sole proprietorships, and public agencies. Provide the treatment facility name, address, and contact person and their information.
- 11.2. Project Information.** Briefly describe the scope of the project (i.e., the activities to be covered by this Order), including site background information and project duration. Identify the discharge class applicable to the project (see section 1.1 of the Order).
- 11.3. Utility Information.** Provide information regarding the local utility agencies contacted for the proposed discharge. Note that Resolution 88-160, adopted by the Regional Water Board on October 19, 1988, urges groundwater dischargers to reclaim their effluent or discharge to a publicly-owned treatment works when reclamation is not technically or economically feasible.
- 11.4. Contact Information.** Provide the name and contact information of the duly authorized representative, design professional engineer, operations and maintenance professional engineer, and Discharger's consultancy. The design professional engineer is responsible for designing the groundwater treatment system and certifying any proposed changes to it. The operation and maintenance professional engineer is responsible for all operations and maintenance activities performed at the treatment facility. Both engineers must be licensed to practice in California. Exceptions to having a licensed operation and maintenance professional engineer overseeing operation and maintenance activities must be clearly explained, and the Discharger must describe how this exception would not compromise operation and maintenance activities at the treatment facility.
- 11.5. Billing Information.** Provide the billing contact information for the Discharger.
- 11.6. Discharge Location Information.** Identify the receiving water into which the discharge flows into and confirm whether access to the receiving water is restricted or unrestricted. Identify the salinity of receiving water. Identify all location points where the facility discharges wastewater and provide latitudes and longitudes for discharge locations (using decimal degrees with five decimal places). Briefly describe the discharge flow path from the effluent monitoring location to the outfall on the receiving water.
- 11.7. Treatment System Information.** Provide the groundwater treatment design capacity certified by the Design Professional Engineer identified in section 4

above. Narratively describe potential pollutants of concern in the discharge. Describe the type of water reclamation (e.g., dust suppression, soil compaction, landscape or agriculture irrigation, or industrial water supply) and expected discharge frequency. Note that this Order does not cover water reclamation consisting of recharge or reinjection. List all the treatment process units, specifying their quantities and general design details.

11.8. Monitoring Data. Existing dischargers must summarize influent and effluent monitoring data collected during the current permit term in an electronic spreadsheet (e.g., Microsoft Excel). New applicants must provide untreated groundwater monitoring data for all listed pollutants that are representative of the groundwater quality at the proposed project site.

11.9. Certified Engineering Report. The Certified Engineering Report is a comprehensive report detailing the process units of the groundwater extraction and treatment system. It certifies that the proposed treatment system will treat the discharge and meet the requirements in this Order. The report must be prepared by, or under the supervision of, a Professional Engineer licensed to practice in California, and signed and stamped by the same, as required by the California Business and Profession Code section 6735. The report must provide site background information and briefly summarize environmental investigations concerning groundwater contamination at the site, if any. The description of the treatment system may include dewatering wells, settling tanks, particulate filters, carbon filters, chemical additives, etc. Applicants must include safety data sheets for any chemical additive proposed for use. Additionally, the report must include:

11.9.1. Location Map. Topographic map showing the legal facility boundaries, treatment system location, effluent monitoring location, and storm drain entry point location (if applicable).

11.9.2. Discharge Flow Path Map. An aerial map or satellite image illustrating the proposed path of the discharge from the effluent monitoring location to the outfall on the receiving water. All applicable topographic features, including streets and receiving waters, must be identified on the map.

11.9.3. Process Flow Diagram. A diagram showing the layout of the treatment process units, monitoring locations (e.g., influent, midstream [see Attachment E Table E-1], and effluent), and process wastewater flow from the intake to the exit point of the treatment system. An example of such a diagram is below:

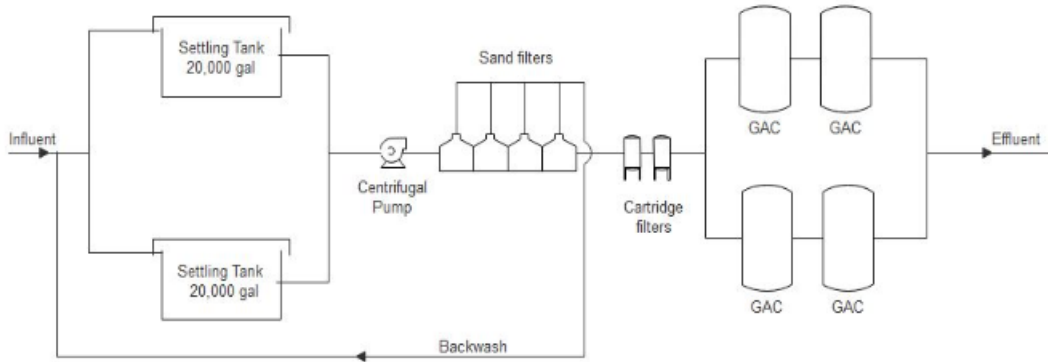

11.9.4. Contingency Plan. Provide a plan that describes the procedures in place to ensure that the Discharger's facility remains in, or are rapidly returned to, operation in the event of equipment failure or another type of emergency, as described in Provision 6.3.3 of this Order.