

**CALIFORNIA REGIONAL WATER QUALITY CONTROL BOARD
SAN FRANCISCO BAY REGION**

1515 Clay Street, Suite 1400, Oakland, California 94612
www.waterboards.ca.gov/sanfranciscobay

**ORDER R2-2025-0029
NPDES PERMIT CAG912002**

**GENERAL WASTE DISCHARGE REQUIREMENTS FOR DISCHARGES OF
GROUNDWATER**

This Order was adopted on:	December 10, 2025
This Order shall become effective on:	July 1, 2026
This Order shall expire on:	June 30, 2031
CIWQS regulatory measure number:	463646

To obtain coverage under this Order, prospective dischargers must submit the Notice of Intent (NOI) form shown in Attachment B and a filing fee equivalent to the first year's annual fee. Discharge is not authorized until the California Regional Water Quality Control Board, San Francisco Bay Region (Regional Water Board), Executive Officer issues an Authorization to Discharge. Authorized Dischargers that intend to continue discharging after this Order's expiration date shall file a new NOI form no later than **October 3, 2030**.

The U.S. Environmental Protection Agency (U.S. EPA) and the Regional Water Board have classified discharges under this general National Pollutant Discharge Elimination System (NPDES) permit (General Permit) as "**minor**."

I do hereby certify that this Order with all attachments is a full, true, and correct copy of the Order adopted by the Regional Water Board on the date indicated above.

Eileen M. White
Digitally signed by Eileen M. White
Date: 2025.12.12 19:18:39 -08'00'
Water Board

Eileen White, Executive Officer

CONTENTS

1. GENERAL PERMIT SCOPE.....	3
2. FINDINGS.....	3
3. DISCHARGE PROHIBITIONS.....	4
4. EFFLUENT LIMITATIONS.....	5
5. RECEIVING WATER LIMITATIONS.....	8
6. PROVISIONS.....	8

TABLES

TABLE 1. EFFLUENT LIMITATIONS FOR CLASS 1, 2, AND 3 DISCHARGES.....	5
TABLE 2. EFFLUENT LIMITATIONS FOR CLASS 4 DISCHARGES.....	6

ATTACHMENTS

ATTACHMENT A – DEFINITIONS AND ABBREVIATIONS	A-1
ATTACHMENT B – NOTICE OF INTENT FORM	B-1
ATTACHMENT C – NOTICE OF TERMINATION FORM	C-1
ATTACHMENT D – STANDARD PROVISIONS.....	D-1
ATTACHMENT E – MONITORING AND REPORTING PROGRAM	E-1
ATTACHMENT F – FACT SHEET	F-1
ATTACHMENT G – PRIORITY POLLUTANTS	G-1

1. GENERAL PERMIT SCOPE

These general waste discharge requirements (WDRs) shall serve as an NPDES General Permit for discharges of groundwater to surface waters, such as creeks, streams, rivers (including flood control canals), lakes, and San Francisco Bay.

1.1. Discharges Covered by this General Permit

This Permit applies to the following types of discharges:

- 1.1.1. Aquifer reclamation program well discharges (Class 1);
- 1.1.2. Reverse osmosis concentrate from aquifer reclamation program well discharges to estuarine or marine receiving waters (Class 2);
- 1.1.3. Groundwater discharges at flows of 10,000 gallons per day or greater requiring minimal or no treatment (Class 3); and
- 1.1.4. All groundwater discharges requiring treatment (Class 4). Class 4 dischargers are typically located at construction sites and active or closed cleanup sites and treat for priority pollutants listed in Attachment G of this Order.

1.2. Discharges Not Covered by this General Permit

This Order does not apply to the following types of discharges:

- 1.2.1. Groundwater discharges at flows of less than 10,000 gallons per day requiring no treatment;
- 1.2.2. Stormwater discharges not commingled with groundwater;
- 1.2.3. Discharges to sanitary sewer systems;
- 1.2.4. Sewage discharges;
- 1.2.5. Underground groundwater injection;
- 1.2.6. Discharges covered under an individual NPDES permit or WDRs; or
- 1.2.7. Discharges to the Pacific Ocean.

2. FINDINGS

- 2.1. **Legal Authorities.** This Order serves as general WDRs pursuant to California Water Code article 4, chapter 4, division 7 (commencing with § 13260). This Order also serves as a general NPDES permit issued pursuant to federal Clean Water Act (CWA) section 402 and implementing regulations adopted by U.S. EPA and Water Code chapter 5.5, division 7 (commencing with § 13370). The Regional Water Board has authority to issue general WDRs under Water Code section

13263, subdivision (i) and issue general NPDES permits under 40 C.F.R. section 122.28.

- 2.2. Background and Rationale for Requirements.** This Order covers discharges previously covered by two separate orders: Order R2-2017-0048, as amended by Order R2-2018-0050, and Order R2-2018-0026. The Regional Water Board developed the requirements in this Order based on information submitted as part of the application process, information obtained through monitoring and reporting programs, and other available information. The Fact Sheet contains background information and rationale for the requirements in this Order and is hereby incorporated into and constitutes findings for this Order. Attachments A through E and G are also incorporated into this Order.
- 2.3. Provisions and Requirements Implementing State Law.** Discharge Prohibitions 3.4 and 3.5 and the receiving water limitations in section 5 of this Order are included to implement State law only. Discharge Prohibitions 3.4 and 3.5 and the receiving water limitations in section 5 are not required or authorized under the federal CWA; consequently, violations of these prohibitions and the receiving water limitations in section 5 are not subject to the enforcement remedies that are available for NPDES violations.
- 2.4. Notification of Interested Parties.** The Regional Water Board notified prospective enrollees and interested agencies and persons of its intent to prescribe these WDRs, and has provided an opportunity to submit written comments and recommendations. Fact Sheet section 8.1 provides details regarding the notification.
- 2.5. Consideration of Public Comment.** The Regional Water Board, in a public meeting, heard and considered all comments pertaining to the discharge. Fact Sheet section 8.3 provides details regarding the public hearing.

THEREFORE, IT IS HEREBY ORDERED that Order R2-2017-0048, as amended by Order R2-2018-0050, and Order R2-2018-0026 (previous orders) are rescinded upon the effective date of this Order, except for enforcement purposes, and, in order to meet the provisions contained in Water Code division 7 (commencing with § 13000) and regulations adopted thereunder, and the provisions of the CWA and regulations and guidelines adopted thereunder, the Discharger shall comply with the requirements in this Order. This action in no way prevents the Regional Water Board from taking enforcement action for violations of the previous orders.

3. DISCHARGE PROHIBITIONS

- 3.1.** Discharge of waste at a location or in a manner different than described in an NOI and Authorization to Discharge is prohibited.
- 3.2.** Discharge of sanitary wastewater (sewage) is prohibited.

- 3.3.** Discharge of floating oil, residual petroleum products, or other floating materials from any activity is prohibited.
- 3.4.** The treatment of pollutants shall not create nuisance as defined by California Water Code section 13050.
- 3.5.** Bypass or overflow of untreated or partially-treated groundwater to waters of the state or waters of the United States from a treatment system, or any collection or transport system or pump station tributary to the treatment system, is prohibited, except in accordance with Attachment D section 1.7.2. The Regional Water Board may take enforcement action against a Discharger for bypass, except under the circumstances listed in Attachment D section 1.7.3.

4. EFFLUENT LIMITATIONS

- 4.1.** Class 1, Class 2, and Class 3 discharges are subject to the following effluent limitations with compliance measured at Monitoring Location EFF-00n, as described in the Monitoring and Reporting Program (MRP), Attachment E:

Table 1. Effluent Limitations for Class 1, 2, and 3 Discharges

Parameter	Units	Receiving Waters Used as Drinking Water ^[1]		Other Receiving Waters	
		Average Monthly	Maximum Daily	Average Monthly	Maximum Daily
pH	standard units	Between 6.5 and 8.5 at all times			
Chlorine, Total Residual ^[2]	mg/L	0.0 mg/L at all times			
Cadmium, Total Recoverable	µg/L	0.9	1.8	0.9	1.8
Copper, Total Recoverable ^[3]					
<i>Lower or South SF Bay Discharge ^[4]</i>	µg/L	10.	20.	10.	20.
<i>Central SF Bay Discharge ^[4]</i>	µg/L	5.4	11	5.4	11
<i>Suisun or San Pablo Bay Discharge ^[4]</i>	µg/L	7.1	14	7.1	14
<i>Freshwater Discharge</i>	µg/L	7.0	14	7.0	14
Lead, Total Recoverable	µg/L	2.6	5.2	2.6	5.2
Nickel, Total Recoverable ^[3]					
<i>Lower or South SF Bay Discharge ^[4]</i>	µg/L	22	44	22	44
<i>Central SF Bay Discharge ^[4]</i>	µg/L	10.	21	10.	21
<i>Suisun or San Pablo Bay Discharge ^[4]</i>	µg/L	25	50.	25	50.
<i>Freshwater Discharge</i>	µg/L	43	86	43	86
Selenium, Total Recoverable ^[5]	µg/L	2.5	5.1	-	-

Footnotes:

- [1] "Receiving Waters Used as Drinking Water" are surface waters with existing or potential beneficial uses of "Municipal and Domestic Supply" or "Groundwater Recharge," or both. Groundwater recharge beneficial uses may include recharge areas to maintain salt balance or to halt saltwater intrusion to freshwater aquifers.
- [2] This limit shall be applied as an instantaneous maximum. There shall be no detectable residual chlorine in the effluent (as explained in Attachment E section 6.2.5, a non-detect result using a detection level equal to or less than 0.1 milligrams per liter [mg/L] will not be considered out of compliance).
- [3] The applicable limit depends on the sub-embayment into which the discharge eventually flows. Freshwater limits apply when the receiving water salinity is no greater than one part per thousand at least 95 percent of the time.
- [4] These limits also apply to discharges to tidally influenced reaches of waters draining to San Francisco, San Pablo, and Suisun Bays.
- [5] These limits apply to discharges to freshwater and estuarine reaches of Stevens Creek in Santa Clara County. Estuarine reaches are determined where the receiving water salinity is between one and ten parts per thousand at least 95 percent of the time.

4.2. Class 4 discharges are subject to the following effluent limitations with compliance measured at Monitoring Location EFF-00n, as described in the MRP, Attachment E:

Table 2. Effluent Limitations for Class 4 Discharges

Parameter	Units	Receiving Waters Used as Drinking Water ^[1]		Other Receiving Waters	
		Average Monthly	Maximum Daily	Average Monthly	Maximum Daily
pH	standard units	Between 6.5 and 8.5 at all times			
Chlorine, Total Residual ^[2]	mg/L	0.0 mg/L at all times			
Antimony, Total Recoverable	µg/L	12	6.0	4,300	8,600
Arsenic, Total Recoverable	µg/L	20	10.	30.	59
Cadmium, Total Recoverable	µg/L	0.90	1.8	0.90	1.8
Chromium VI	µg/L	-	10.	8.1	16
Copper, Total Recoverable ^[3]					
<i>Lower or South SF Bay Discharge ^[4]</i>	µg/L	10.	20.	10.	20.
<i>Central SF Bay Discharge ^[4]</i>	µg/L	5.4	11	5.4	11
<i>Suisun or San Pablo Bay Discharge ^[4]</i>	µg/L	7.1	14	7.1	14
<i>Freshwater Discharge</i>	µg/L	7.0	14	7.0	14
Lead, Total Recoverable	µg/L	2.6	5.2	2.6	5.2
Mercury, Total Recoverable	µg/L	0.050	0.10	0.050	0.10
Nickel, Total Recoverable ^[3]					
<i>Lower or South SF Bay Discharge ^[4]</i>	µg/L	22	44	22	44
<i>Central SF Bay Discharge ^[4]</i>	µg/L	10.	21	10.	21
<i>Suisun or San Pablo Bay Discharge ^[4]</i>	µg/L	25	50.	25	50.
<i>Freshwater Discharge</i>	µg/L	43	86	43	86
Selenium, Total Recoverable ^[5]	µg/L	2.5	5.1	-	-

Parameter	Units	Receiving Waters Used as Drinking Water ^[1]		Other Receiving Waters	
		Average Monthly	Maximum Daily	Average Monthly	Maximum Daily
Silver, Total Recoverable	µg/L	1.1	2.2	1.1	2.2
Thallium, Total Recoverable	µg/L	1.7	2.0	6.3	13
Zinc, Total Recoverable	µg/L	47	95	47	95
Cyanide	µg/L	2.4	4.8	2.4	4.8
Dichlorobromomethane	µg/L	0.56	1.1	46	92
Benzene	µg/L	-	0.50	-	0.50
Chloroform	µg/L	-	1.9	-	1.9
1,1-Dichloroethane	µg/L	-	0.50	-	0.50
1,2-Dichloroethane	µg/L	0.38	0.50	-	0.50
1,1-Dichloroethylene	µg/L	0.057	0.11	-	0.50
Ethylbenzene	µg/L	-	0.50	-	0.50
Methylene Chloride	µg/L	4.7	9.4	1,600	3,200
Tetrachloroethylene	µg/L	-	0.50	-	0.50
Toluene	µg/L	-	0.50	-	0.50
Cis-1,2-Dichloroethylene	µg/L	-	0.50	-	0.50
Trans-1,2-Dichloroethylene	µg/L	-	0.50	-	0.50
1,1,1-Trichloroethane	µg/L	-	0.50	-	0.50
1,1,2-Trichloroethane	µg/L	-	0.50	-	0.50
Trichloroethylene	µg/L	-	0.65	-	0.65
Vinyl Chloride	µg/L	-	0.50	-	0.90
2,4-Dichlorophenol	µg/L	93	190	790	1,600
2,4,6-Trichlorophenol	µg/L	2.1	4.2	6.5	13
Benzidine	µg/L	0.00012	0.00024	0.00054	0.0011
Bis(2-Chloroethyl)Ether	µg/L	0.031	0.062	1.4	2.8
Chrysene	µg/L	0.0044	0.0088	0.049	0.098
3,3-Dichlorobenzidine	µg/L	0.04	0.08	0.077	0.15
2,4-Dinitrotoluene	µg/L	0.11	0.22	9.1	18
1,2-Diphenylhydrazine	µg/L	0.040	0.080	0.54	1.1
Hexachlorobenzene	µg/L	0.00075	0.0015	0.00077	0.0015
1,2,4-Trichlorobenzene	µg/L	10.	5.0	-	-
Xylenes	µg/L	-	0.50	-	0.50
Methyl Tertiary-butyl Ether	µg/L	-	0.50	-	0.50
TPH as gasoline	µg/L	-	50.	-	50.
TPH as diesel	µg/L	-	50.	-	50.
TPH as motor oil	µg/L	-	100	-	100
Per- and Polyfluoroalkyl Substances (PFAS)					
<i>Perfluorooctanoic acid (PFOA)</i>	ng/L	4.0	-	4.0	-
<i>Perfluorooctane sulfonic acid (PFOS)</i>	ng/L	4.0	-	4.0	-

Parameter	Units	Receiving Waters Used as Drinking Water ^[1]		Other Receiving Waters	
		Average Monthly	Maximum Daily	Average Monthly	Maximum Daily
<i>Perfluorohexane sulfonic acid (PFHxS)</i>	ng/L	10.	-	10.	-
<i>Perfluorononanoic acid (PFNA)</i>	ng/L	10.	-	10.	-
<i>Hexafluoropropylene oxide dimer acid (HFPO-DA)</i>	ng/L	10.		10.	-

Footnotes:

- [1] "Receiving Waters Used as Drinking Water" are surface waters with existing or potential beneficial uses of "Municipal and Domestic Supply" or "Groundwater Recharge," or both. Groundwater recharge beneficial uses may include recharge areas to maintain salt balance or to halt saltwater intrusion to freshwater aquifers.
- [2] This limit shall be applied as an instantaneous maximum. There shall be no detectable residual chlorine in the effluent (as explained in Attachment E section 6.2.5, a non-detect result using a detection level equal to or less than 0.1 mg/L will not be considered out of compliance).
- [3] The applicable limit depends on the sub-embayment into which the discharge eventually flows. Freshwater limits apply when the receiving water salinity is no greater than one part per thousand at least 95 percent of the time.
- [4] These limits also apply to discharges to tidally influenced reaches of waters draining to San Francisco, San Pablo, and Suisun Bays.
- [5] These limits apply to discharges to freshwater and estuarine reaches of Stevens Creek in Santa Clara County. Estuarine reaches are determined where the receiving water salinity is between one and ten parts per thousand at least 95 percent of the time.

5. RECEIVING WATER LIMITATIONS

Discharges shall not cause an exceedance of the aquatic toxicity objectives specified in section II.C of the *State Policy for Water Quality Control: Toxicity Provisions* (Toxicity Provisions) in the receiving waters.

6. PROVISIONS**6.1. Standard Provisions**

- 6.1.1. The Discharger shall comply with all "Standard Provisions" in Attachment D.
- 6.1.2. If there is any conflict, duplication, or overlap between provisions in this Order, the more stringent provision shall apply.

6.2. Monitoring and Reporting Provisions

The Discharger shall comply with the Monitoring and Reporting Program (Attachment E) and future revisions thereto, and applicable monitoring and reporting requirements in Attachments D and G. The Executive Officer may specify additional monitoring and reporting requirements in individual Authorizations to Discharge.

6.3. Special Provisions

- 6.3.1. **Reopener Provisions.** The Regional Water Board may modify or reopen this Order prior to its expiration date in any of the following circumstances as allowed by law or as otherwise authorized by law. A Discharger may request a permit modification based on any of these circumstances. With any such request, the Discharger shall include antidegradation and anti-backsliding analyses as necessary.
- 6.3.1.1. If present or future investigations demonstrate that the discharges governed by this Order have or will have a reasonable potential to cause or contribute to adverse impacts on water quality or beneficial uses of the receiving waters;
- 6.3.1.2. If new or revised water quality objectives or total maximum daily loads (TMDLs) come into effect for San Francisco Bay or contiguous water bodies (whether statewide, regional, or site-specific). In such cases, effluent limitations in this Order may be modified as necessary to reflect the updated water quality objectives or wasteload allocations. Adoption of the effluent limitations in this Order is not intended to restrict in any way future modifications based on legally adopted water quality objectives or TMDLs or as otherwise permitted under federal regulations governing NPDES permit modifications;
- 6.3.1.3. If metal translator, dilution, or other water quality studies provide a basis for determining that a permit condition should be modified;
- 6.3.1.4. If a State Water Board precedential decision, new policy, new law, or new regulation is adopted; or
- 6.3.1.5. If an administrative or judicial decision on a separate NPDES permit or WDRs addresses requirements similar to this discharge.
- 6.3.2. **Application for General Permit Coverage and Authorization to Discharge**
- 6.3.2.1. **Notice of Intent (NOI).** A prospective Discharger seeking an Authorization to Discharge pursuant to this Order shall complete and submit the NOI form in Attachment B of this Order. The Executive Officer may modify the NOI form in Attachment B or require additional information prior to authorizing any discharge. Dischargers authorized to discharge under the previous order that submitted an NOI form at the end of the previous order term need not submit a new NOI form to renew their Authorization to Discharge.
- 6.3.2.2. **Authorization to Discharge.** If the Executive Officer concludes that a proposed or previously authorized discharge is eligible for coverage under this Order, the Executive Officer will issue an Authorization to Discharge. Upon the effective date of the Authorization of Discharge, the Discharger shall comply with the requirements of this Order. Any non-compliance with this Order's requirements shall constitute a violation of the CWA and Water Code and may be grounds for one or more of the following: enforcement;

termination, revocation and reissuance, or modification of the Authorization to Discharge; issuance of an individual permit; or denial of an application for reissuance.

- 6.3.2.3. **Facility Modifications.** At least 30 days prior to any significant facility modification (e.g., change in treatment system design, or outfall location), the Discharger proposing the modification shall submit a modified NOI form (e.g., a mark-up of the original NOI form showing all changes and including a new signature and date). The Discharger shall include a letter describing the changes, their purpose, when they are to go into effect, and any new or additional measures taken or planned to prevent potential non-compliance with this Order's requirements. If the Executive Officer concludes that the modifications warrant modifications to the Authorization to Discharge, the Executive Officer will issue a modified Authorization to Discharge.
- 6.3.2.4. **Discharge Termination.** A Discharger may terminate coverage under this Order by submitting a complete and signed Notice of Termination form (see Attachment C of this Order). When an individual NPDES permit is issued to a Discharger otherwise subject to this Order, the applicability of this Order to the individual NPDES permittee automatically terminates on the effective date of the individual permit. The Executive Officer may also require a Discharger covered under this Order to apply for and obtain an individual NPDES permit for any of the causes specified for an individual permit as set forth in 40 C.F.R. section 122.28(b)(3) as described in section 6.3.2.5 of this Order.
- 6.3.2.5. **Need for Individual NPDES Permit.** The Executive Officer may require any Discharger authorized to discharge pursuant to this Order to subsequently apply for and obtain an individual NPDES permit in the following circumstances:
- 6.3.2.5.1. The Discharger is not in compliance with the requirements of this Order;
 - 6.3.2.5.2. A change has occurred in the availability of demonstrated technology or practices for the control or abatement of pollutants from the facility;
 - 6.3.2.5.3. Effluent limitation guidelines are promulgated for the discharges covered by this Order;
 - 6.3.2.5.4. A new or revised water quality control plan containing requirements applicable to the discharge is approved; or
 - 6.3.2.5.5. Any other condition specified in 40 C.F.R. section 122.28(b)(3) is met.
- 6.3.3. **Contingency Plan.** The Discharger shall maintain a Contingency Plan that describes procedures to ensure that its facilities remain in, or are rapidly returned to, operation in the event of equipment failure or another type of emergency, such as an employee strike, a strike by suppliers or maintenance

services, a power outage, vandalism, an earthquake, or a fire. The Discharger shall regularly review, revise, and update, as necessary, its Contingency Plan so the document remains useful and relevant to current practices. At a minimum, the Discharger shall review the Contingency Plan annually. The Discharger shall include, in each Annual Report, a description or summary of its review and evaluation procedures, recommended or planned actions, and an estimated time schedule for implementing any improvements. The Discharger shall update these documents as necessary. The Contingency Plan shall, at a minimum, contain the provisions below:

- 6.3.3.1. Provision of personnel for operating treatment facilities during employee strikes or strikes against contractors providing services;
 - 6.3.3.2. Maintenance of adequate supplies necessary to continue operation of treatment facilities;
 - 6.3.3.3. Provision of alarm systems to notify operators of abnormal treatment conditions and help prevent equipment failures and unauthorized discharges;
 - 6.3.3.4. Provision of emergency standby power;
 - 6.3.3.5. Protection against vandalism;
 - 6.3.3.6. Expedient action to repair failures of, or damage to, equipment; and
 - 6.3.3.7. Reporting of spills and discharges of waste, including measures taken to clean up the effects of such discharges.
- 6.3.4. **Spill Prevention Plan.** The Discharger shall maintain a Spill Prevention Plan to prevent accidental discharges and to minimize the effects of any such discharges. The Spill Prevention Plan shall do the following:
- 6.3.4.1. Identify the possible sources of accidental discharge, untreated or partially-treated waste bypass, and polluted drainage;
 - 6.3.4.2. State when current facilities and procedures became operational and evaluate their effectiveness; and
 - 6.3.4.3. Predict the effectiveness of any proposed facilities and procedures and provide an implementation schedule with interim and final dates when the proposed facilities and procedures will be constructed, implemented, or operational.
- 6.3.5. **Operation and Maintenance Manual.** The Discharger shall maintain an Operation and Maintenance Manual to provide the plant and regulatory personnel with a source of information describing all equipment, recommended operational strategies, process control monitoring, and maintenance activities. To remain a useful and relevant document, the Operation and Maintenance

Manual shall be kept updated to reflect significant changes in treatment facility equipment and operational practices. The Operation and Maintenance Manual shall be maintained in usable condition and be available for reference and use by all relevant personnel and Regional Water Board staff.

6.3.6. **Water Reclamation**

- 6.3.6.1. **Reclamation Activities.** Water reclamation activities shall be described in the Discharger's NOI, including the method of any additional treatment and location and type of water reclamation. Reclaimed water quality shall be consistent with the effluent limitations applicable to the discharge.
- 6.3.6.2. **Public Health.** Adequate measures shall be taken to minimize public contact with reclaimed water and to prevent breeding of flies, mosquitoes, and other vectors of public health significance during or after the reclamation process.
- 6.3.6.3. **Public Awareness.** Public warnings shall be posted to advise the public that reclaimed water is not suitable for drinking. Signs shall be posted in the area, and all reclamation water valves and outlets shall be visibly labeled.
- 6.3.6.4. **Cross-connections.** There shall be no cross-connection between the potable water supply and piping containing treated groundwater intended for reclamation.
- 6.3.7. **No Preemption.** This Order does not preempt or supersede the authority of municipalities, flood control agencies, or other agencies to prohibit, restrict, or control discharges to storm drain systems or other watercourses subject to their jurisdiction.

ATTACHMENT A – DEFINITIONS AND ABBREVIATIONS

DEFINITIONS

Arithmetic Mean (μ)

Also called the average, sum of measured values divided by the number of samples. For ambient water concentrations, the arithmetic mean is calculated as follows:

$$\text{Arithmetic mean} = \mu = \Sigma x / n$$

where: Σx is the sum of the measured ambient water concentrations,
and n is the number of samples

Average Monthly Effluent Limitation (AMEL)

Highest allowable average of daily discharges over a calendar month, calculated as the sum of all daily discharges measured during a calendar month divided by the number of daily discharges measured during that month.

Average Weekly Effluent Limitation (AWEL)

Highest allowable average of daily discharges over a calendar week (Sunday through Saturday), calculated as the sum of all daily discharges measured during a calendar week divided by the number of daily discharges measured during that week.

Bioaccumulative

Taken up by an organism from its surrounding medium through gill membranes, through epithelial tissue, or from food and subsequently concentrated and retained in the body of the organism.

Carcinogenic

Known to cause cancer in living organisms.

Coefficient of Variation (CV)

Measure of data variability calculated as the estimated standard deviation divided by the arithmetic mean of the observed values.

Daily Discharge

Either: (1) the total mass of a constituent discharged over a calendar day (12:00 a.m. through 11:59 p.m.) or any 24-hour period that reasonably represents a calendar day for purposes of sampling (as specified in the permit) for a constituent with limitations expressed in units of mass; or (2) the unweighted arithmetic mean measurement of a constituent over a day for a constituent with limitations expressed in other units of measurement (e.g., concentration).

The daily discharge may be determined by the analytical results of a composite sample taken over the course of one day (a calendar day or other 24-hour period defined as a day) or by the arithmetic mean of analytical results from one or more grab samples taken over the course of the day.

For composite sampling, if 1 day is defined as a 24-hour period other than a calendar day, the analytical result for the 24-hour period is considered the result for the calendar day in which the 24-hour period ends.

Detected, but Not Quantified (DNQ)

Sample results less than the RL, but greater than or equal to the laboratory's MDL. Sample results reported as DNQ are estimated concentrations.

Dilution Credit

Amount of dilution granted to a discharge in the calculation of a water quality-based effluent limitation, based on the allowance of a specified mixing zone. It is calculated from the dilution ratio or determined through conducting a mixing zone study or modeling of the discharge and receiving water.

Effluent Concentration Allowance (ECA)

Value derived from the water quality criterion or objective, dilution credit, and ambient background concentration that is used, in conjunction with the CV for the effluent monitoring data, to calculate a long-term average (LTA) discharge concentration. The ECA has the same meaning as wasteload allocation (WLA) as used in U.S. EPA guidance (*Technical Support Document for Water Quality-based Toxics Control*, March 1991, second printing, EPA/505/2-90-001).

Enclosed Bays

Indentations along the coast that enclose an area of oceanic water within distinct headlands or harbor works. Enclosed bays include all bays where the narrowest distance between the headlands or outermost harbor works is less than 75 percent of the greatest dimension of the enclosed portion of the bay. Enclosed bays include, but are not limited to, Humboldt Bay, Bodega Harbor, Tomales Bay, Drake's Estero, San Francisco Bay, Morro Bay, Los Angeles-Long Beach Harbor, Upper and Lower Newport Bay, Mission Bay, and San Diego Bay. Enclosed bays do not include inland surface waters or ocean waters.

Estimated Chemical Concentration

Concentration that results from the confirmed detection of a substance below the ML by the analytical method.

Estuaries

Waters, including coastal lagoons, located at the mouths of streams that serve as areas of mixing for fresh and ocean waters. Coastal lagoons and mouths of streams that are temporarily separated from the ocean by sandbars shall be considered estuaries. Estuarine waters are considered to extend from a bay or the open ocean to a point upstream where there is no significant mixing of fresh water and seawater. Estuarine waters included, but are not limited to, the Sacramento-San Joaquin Delta, as defined in Water Code section 12220; Suisun Bay; Carquinez Strait downstream to the Carquinez Bridge; and appropriate areas of the Smith, Mad, Eel, Noyo, Russian, Klamath, San Diego, and Otay rivers. Estuaries do not include inland surface waters or ocean waters.

Grab Sample

An individual sample collected during a short period not exceeding 15 minutes. Grab samples represent only the condition that exists at the time the sample is collected

Inland Surface Waters

All surface waters of the state that are not the ocean, enclosed bays, or estuaries.

Instantaneous Maximum Effluent Limitation

Highest allowable value for any single grab sample or aliquot (i.e., each grab sample or aliquot is independently compared to the instantaneous maximum limitation).

Instantaneous Minimum Effluent Limitation

Lowest allowable value for any single grab sample or aliquot (i.e., each grab sample or aliquot is independently compared to the instantaneous minimum limitation).

Maximum Daily Effluent Limitation (MDEL)

Highest allowable daily discharge of a pollutant, over a calendar day (or 24-hour period). For pollutants with limitations expressed in units of mass, the daily discharge is calculated as the total mass of the pollutant discharged over the day. For pollutants with limitations expressed in other units of measurement, the daily discharge is calculated as the arithmetic mean measurement of the pollutant over the day.

Median

Middle measurement in a data set. The median of a data set is found by first arranging the measurements in order of magnitude (either increasing or decreasing order). If the number of measurements (n) is odd, then the median = $X_{(n+1)/2}$. If n is even, then the median = $(X_{n/2} + X_{(n/2+1)})/2$ (i.e., the midpoint between $n/2$ and $n/2+1$).

Method Detection Limit (MDL)

Minimum concentration of a substance that can be reported with 99 percent confidence that the measured concentration is distinguishable from method blank results, as defined in 40 C.F.R. part 136, Appendix B.

Minimum Level (ML)

Concentration at which the entire analytical system must give a recognizable signal and acceptable calibration point. The ML is the concentration in a sample that is equivalent to the concentration of the lowest calibration standard analyzed by a specific analytical procedure, assuming that all the method specified sample weights, volumes, and processing steps have been followed.

Mixing Zone

Limited volume of receiving water allocated for mixing with a wastewater discharge where water quality criteria can be exceeded without causing adverse effects to the overall water body.

Not Detected (ND)

Sample results less than the laboratory's MDL.

Persistent Pollutants

Substances for which degradation or decomposition in the environment is nonexistent or very slow.

Pollution Prevention

Any action that causes a net reduction in the use or generation of a hazardous substance or other pollutant discharged into water and includes, but is not limited to, input change, operational improvement, production process change, and product reformulation (as defined in Water Code section 13263.3). Pollution prevention does not include actions that merely shift a pollutant in wastewater from one environmental medium to another environmental medium, unless clear environmental benefits of such an approach are identified to the satisfaction of the State Water Resources Control Board or Regional Water Board.

Priority Pollutants

Those constituents referred to in 40 C.F.R. part 122 as promulgated in the Federal Register, Vol. 65, No. 97, Thursday, May 18, 2000, also known as the California Toxics Rule.

Reporting Level (RL)

ML (and its associated analytical method) chosen by the Discharger for reporting and compliance determination from the MLs included in this Order, including an additional factor if applicable as discussed herein. For priority pollutants, the MLs included in this Order correspond to approved analytical methods for reporting a sample result that are selected by the Regional Water Board either from State Implementation Plan (SIP) Appendix 4 in accordance with SIP section 2.4.2 or established in accordance with SIP section 2.4.3. The ML is based on the proper application of method-based analytical procedures for sample preparation and the absence of any matrix interferences. Other factors may be applied to the ML depending on the specific sample preparation steps employed. For example, the treatment typically applied in cases where there are matrix-effects is to dilute the sample or sample aliquot by a factor of ten. In such cases, this additional factor must be applied to the ML in the computation of the RL.

Source of Drinking Water

Any water designated as municipal or domestic supply (MUN) beneficial use.

Standard Deviation (σ)

Measure of variability calculated as follows:

$$\text{Standard deviation} = \sigma = (\Sigma[(x - \mu)^2]/(n - 1))^{0.5}$$

where: x is the observed value

μ is the arithmetic mean of the observed values

n is the number of samples

Toxicity Reduction Evaluation (TRE)

Study conducted in a step-wise process designed to identify the causative agents of effluent or ambient toxicity, isolate the sources of toxicity, evaluate the effectiveness of

toxicity control options, and then confirm the reduction in toxicity. The first steps of the TRE consist of the collection of data relevant to the toxicity, including additional toxicity testing, and an evaluation of facility operations and maintenance practices, and best management practices. A Toxicity Identification Evaluation (TIE) may be required as part of the TRE, if appropriate. A TIE is a set of procedures to identify the specific chemicals responsible for toxicity. These procedures are performed in three phases (characterization, identification, and confirmation) using aquatic organism toxicity tests.

ABBREVIATIONS

%	Percent
µg/L	Micrograms per liter
µg/kg	Micrograms per kilogram
µg/sq. ft.	Micrograms per square feet
1/Blending Event	Once per blending event
1/Day	Once per day
1/Month	Once per month
1/Quarter	Once per quarter
1/Week	Once per week
1/Year	Once per year
2/Month	Two times per month
2/Week	Twice per week
2/Year	Twice per year
3/Week	Three times per week
4/Week	Four times per week
5/Week	Five times per week
AMEL	Average monthly effluent limitation
AWEL	Average weekly effluent limitation
B	Background concentration
C	Water quality criterion or objective
C-24	24-hour composite
CFU/100 mL	Colony forming units per 100 milliliters
Continuous	Measured continuously
Continuous/D	Measured continuously, and recorded and reported daily
Continuous/H	Measured continuously, and recorded and reported hourly
CV	Coefficient of Variation

DNQ	Detected, but not quantified
DL	Detection level
ECA	Effluent Concentration Allowance
Grab	Grab sample
GPM	Gallons per minute
MDEL	Maximum Daily Effluent Limitation
MDL	Method detection limit
MEC	Maximum effluent concentration
MG	Million gallons
mg/L	Milligrams per liter
mg/L as N	Milligrams per liter as nitrogen
MGD	Million gallons per day
ML	Minimum level
MPN/100 mL	Most probable number per 100 milliliters
ND	Not detected
ng/L	Nanograms per liter
NTU	Nephelometric turbidity units
PCBs	Polychlorinated byphenyls
PFAS	Per- and Polyfluoroalkyl Substances (PFAS)
RL	Reporting level
RPA	Reasonable potential analysis
SP	Startup phase
s.u.	Standard pH units
SVOCs	Semi-volatile Organic Compounds
TIE	Toxicity identification evaluation
TRE	Toxicity reduction evaluation
TUa	Acute toxicity units
TUc	Chronic toxicity units
VOCs	Volatile Organic Compounds

ATTACHMENT B – NOTICE OF INTENT FORM

This NOTICE OF INTENT form shall be completed and submitted to apply for authorization or reauthorization to discharge under the Groundwater General Permit, NPDES Permit CAG912002.

1. DISCHARGER INFORMATION AND CERTIFICATION

The following certification shall be signed in accordance with Attachment D section 5.2. The Discharger hereby agrees to comply with and be responsible for all conditions specified in NPDES Permit CAG912002.

I certify under penalty of law that this document and all attachments were prepared under my direction or supervision in accordance with a system designed to assure that qualified personnel properly gather and evaluate the information submitted. Based on my inquiry of the person or persons who manage the system or those persons directly responsible for gathering the information, the information submitted is, to the best of my knowledge and belief, true, accurate, and complete. I am aware that there are significant penalties for submitting false information, including the possibility of fine and imprisonment for knowing violations. (40 C.F.R. § 122.22(d).)			
Signature		Date	
Printed Name		Title	
Company/Owner Name			
Mailing Street Address	City	State	Zip Code
Owner Type (check one) <input type="checkbox"/> Public <input type="checkbox"/> Private <input type="checkbox"/> Other, specify type:		New or Previously Authorized Facility (check one) <input type="checkbox"/> New Facility <input type="checkbox"/> Previously Authorized Facility	
Facility Information			
Facility Name			
Street Address	City	State	Zip Code
Contact Person Name		Title	
Email	Phone Number		

Check here if additional owner information is attached to this form.

2. PROJECT INFORMATION

<p>Project description (must include approximate project completion date)</p>
<p>Discharge Class (please check one)</p> <p><input type="checkbox"/> Class 1: Aquifer reclamation program well discharges</p> <p><input type="checkbox"/> Class 2: Reverse osmosis concentrate from aquifer reclamation program well discharges</p> <p><input type="checkbox"/> Class 3: Groundwater requiring minimal or no treatment (10,000 gallons per day or greater)</p> <p><input type="checkbox"/> Class 4: Groundwater requiring treatment for priority pollutants (e.g. groundwater at construction sites or active or closed cleanup sites. See Attachment G for list of priority pollutants.</p>

3. UTILITY INFORMATION

SANITARY SEWER AGENCY	
<p>Is discharge to the sanitary sewer feasible?</p> <p>Please check one:</p> <p><input type="checkbox"/> Yes</p> <p><input type="checkbox"/> No (explain why):</p> <p><input type="checkbox"/> Not Applicable (explain why):</p>	
Agency Name:	Contact Person Name:
Email:	Phone Number:
STORM DRAIN AGENCY	
<p>Is discharge to the storm drain allowed?</p> <p>Please check one:</p> <p><input type="checkbox"/> Yes</p> <p><input type="checkbox"/> No (explain why)</p> <p><input type="checkbox"/> Not Applicable (explain why)</p>	
Agency Name:	Contact Person Name:
Email:	Phone Number:

4. CONTACT INFORMATION

Duly Authorized Representative: The Discharger's duly authorized representative, on its behalf, may sign and certify permit-required documents in accordance with Attachment D section 5.2.3. This individual shall be responsible for the overall operation of the facility or facility environmental matters.			
Company/Organization			
Name		Title	
Email		Phone Number	
Design Professional Engineer Information (see section 11.4 below)			
Company/Organization			
Name		Title	
CA PE License Number		CA PE License Expiration Date	
Email		Phone Number	
Operation and Maintenance Professional Engineer Information (see section 11.4 below)			
Company/Organization			
Name		Title	
CA PE License Number		CA PE License Expiration Date	
Email		Phone Number	
Consultancy Information			
Company/Organization			
Name		Title	
Email		Phone Number	

5. BILLING INFORMATION

Company/Organization			
Billing Contact Person Name			
Email		Phone Number	
Mailing Street Address		City	State
			Zip Code

6. DISCHARGE LOCATION INFORMATION

Receiving Water Name		
Receiving Water Salinity (in parts per thousand)		
Location	Latitude ^[1]	Longitude ^[1]
Effluent (e.g., EFF-001)		
Storm Drain Entry		
Receiving Water (e.g., RSW-001)		
<p>Discharge path to Receiving Water – describe the complete path of the discharge from the effluent monitoring location to the outfall on the receiving water, including storm drain routes, streets, land features, and distances, as necessary.</p>		

1. Submit latitude and longitude coordinates in decimal degrees with 5 figures to the right of the decimal point.

Check here if monitoring location information is attached to this form.

7. TREATMENT SYSTEM INFORMATION

Groundwater Treatment Design Capacity (gpm):		
Discharge description (describe discharge and potential pollutants of concern):		
Water reclamation (if applicable, describe type of water reclamation, location, and any specific treatment)		
Discharge Frequency Please check all that apply: <input type="checkbox"/> Continuous <input type="checkbox"/> Daily <input type="checkbox"/> Intermittent <input type="checkbox"/> Emergency (explain why):		
Process Unit Information		
Unit Name	Number of units	Brief Description (e.g., filter size, capacity, layout)
Extraction well or sump pump		
Extraction well with dedicated treatment unit		
Settling tank		
Oil-water separator		
Sand filter		
Bag or cartridge filter		
Air stripper		
Adsorption units (activated carbon, organoclay, ion exchange resin)		
Ultrafilters (reverse osmosis, nanofilters)		
Chemical additive (e.g., flocculant, pH adjuster, dechlorinator)		
Other vessels (e.g., equalization tank)		
Water reclamation vessel		
Other (please specify):		

8. MONITORING DATA

For existing dischargers, summarize influent and effluent monitoring data collected during the current permit term for the applicable parameters in sections 7.1 and 7.2, below. Provide the summary dataset in an electronic spreadsheet (e.g., Microsoft Excel). If applicable, provide a separate summary dataset for each effluent monitoring location (Monitoring Location EFF-00n), starting with Monitoring Location EFF-001. **New applicants shall provide influent or groundwater monitoring data for all listed pollutants below.**

8.1. Influent or Groundwater Monitoring Data

CTR No.	Parameter	Units	Maximum Concentration	Method Detection Limit	Test Method	Number of Samples
1	Antimony	µg/L				
2	Arsenic	µg/L				
3	Beryllium	µg/L				
4	Cadmium	µg/L				
5a	Chromium (III)	µg/L				
5b	Chromium (VI)	µg/L				
6	Copper	µg/L				
7	Lead	µg/L				
8	Mercury	µg/L				
9	Nickel	µg/L				
10	Selenium	µg/L				
11	Silver	µg/L				
12	Thallium	µg/L				
13	Zinc	µg/L				
14	Cyanide	µg/L				
15	Asbestos	fibers/L				
16	2,3,7,8-TCDD (Dioxin)	µg/L				
17	Acrolein	µg/L				
18	Acrylonitrile	µg/L				
19	Benzene	µg/L				
20	Bromoform	µg/L				
21	Carbon Tetrachloride	µg/L				
22	Chlorobenzene	µg/L				
23	Chlorodibromomethane	µg/L				
24	Chloroethane	µg/L				
25	2-Chloroethylvinyl ether	µg/L				
26	Chloroform	µg/L				
27	Dichlorobromomethane	µg/L				
28	1,1-Dichloroethane	µg/L				
29	1,2-Dichloroethane	µg/L				
30	1,1-Dichloroethylene	µg/L				
31	1,2-Dichloropropane	µg/L				
32	1,3-Dichloropropylene	µg/L				
33	Ethylbenzene	µg/L				
34	Methyl Bromide	µg/L				

CTR No.	Parameter	Units	Maximum Concentration	Method Detection Limit	Test Method	Number of Samples
35	Methyl Chloride	µg/L				
36	Methylene Chloride	µg/L				
37	1,1,2,2-Tetrachloroethane	µg/L				
38	Tetrachloroethylene	µg/L				
39	Toluene	µg/L				
40	1,2-Trans-Dichloroethylene	µg/L				
41	1,1,1-Trichloroethane	µg/L				
42	1,1,2-Trichloroethane	µg/L				
43	Trichloroethylene	µg/L				
44	Vinyl Chloride	µg/L				
45	2-Chlorophenol	µg/L				
46	2,4-Dichlorophenol	µg/L				
47	2,4-Dimethylphenol	µg/L				
48	2-Methyl- 4,6-Dinitrophenol	µg/L				
49	2,4-Dinitrophenol	µg/L				
50	2-Nitrophenol	µg/L				
51	4-Nitrophenol	µg/L				
52	3-Methyl 4-Chlorophenol	µg/L				
53	Pentachlorophenol	µg/L				
54	Phenol	µg/L				
55	2,4,6-Trichlorophenol	µg/L				
56	Acenaphthene	µg/L				
57	Acenaphthylene	µg/L				
58	Anthracene	µg/L				
59	Benzidine	µg/L				
60	Benzo(a)Anthracene	µg/L				
61	Benzo(a)Pyrene	µg/L				
62	Benzo(b)Fluoranthene	µg/L				
63	Benzo(ghi)Perylene	µg/L				
64	Benzo(k)Fluoranthene	µg/L				
65	Bis(2-Chloroethoxy)Methane	µg/L				
66	Bis(2-Chloroethyl)Ether	µg/L				
67	Bis(2-Chloroisopropyl)Ether	µg/L				
68	Bis(2-Ethylhexyl)Phthalate	µg/L				
69	4-Bromophenyl Phenyl Ether	µg/L				
70	Butylbenzyl Phthalate	µg/L				
71	2-Chloronaphthalene	µg/L				
72	4-Chlorophenyl Phenyl Ether	µg/L				
73	Chrysene	µg/L				
74	Dibenzo(a,h)Anthracene	µg/L				
75	1,2-Dichlorobenzene	µg/L				
76	1,3-Dichlorobenzene	µg/L				
77	1,4-Dichlorobenzene	µg/L				
78	3,3 Dichlorobenzidine	µg/L				

CTR No.	Parameter	Units	Maximum Concentration	Method Detection Limit	Test Method	Number of Samples
79	Diethyl Phthalate	µg/L				
80	Dimethyl Phthalate	µg/L				
81	Di-n-Butyl Phthalate	µg/L				
82	2,4-Dinitrotoluene	µg/L				
83	2,6-Dinitrotoluene	µg/L				
84	Di-n-Octyl Phthalate	µg/L				
85	1,2-Diphenylhydrazine	µg/L				
86	Fluoranthene	µg/L				
87	Fluorene	µg/L				
88	Hexachlorobenzene	µg/L				
89	Hexachlorobutadiene	µg/L				
90	Hexachlorocyclopentadiene	µg/L				
91	Hexachloroethane	µg/L				
92	Indeno(1,2,3-cd)Pyrene	µg/L				
93	Isophorone	µg/L				
94	Naphthalene	µg/L				
95	Nitrobenzene	µg/L				
96	N-Nitrosodimethylamine	µg/L				
97	N-Nitrosodi-n-Propylamine	µg/L				
98	N-Nitrosodiphenylamine	µg/L				
99	Phenanthrene	µg/L				
100	Pyrene	µg/L				
101	1,2,4-Trichlorobenzene	µg/L				
102	Aldrin	µg/L				
103	alpha-BHC	µg/L				
104	beta-BHC	µg/L				
105	gamma-BHC	µg/L				
106	delta-BHC	µg/L				
107	Chlordane (303d listed)	µg/L				
108	4,4'-DDT (303d listed)	µg/L				
109	4,4'-DDE	µg/L				
110	4,4'-DDD	µg/L				
111	Dieldrin (303d listed)	µg/L				
112	alpha-Endosulfan	µg/L				
113	beta-Endosulfan	µg/L				
114	Endosulfan Sulfate	µg/L				
115	Endrin	µg/L				
116	Endrin Aldehyde	µg/L				
117	Heptachlor	µg/L				
118	Heptachlor Epoxide	µg/L				
119-125	PCBs sum (303d listed)	µg/L				
126	Toxaphene	µg/L				
	Chlorine, Total Residual	mg/L				
	Salinity	µg/L				
	Cyanide	µg/L				
	Methyl Tertiary Butyl Ether	µg/L				

CTR No.	Parameter	Units	Maximum Concentration	Method Detection Limit	Test Method	Number of Samples
	TPH as gasoline	µg/L				
	TPH as diesel	µg/L				
	TPH as motor oil	µg/L				
	PFAS, all analytes	ng/L			EPA 1633	
	Municipal Supply Pollutants ^[1]	µg/L				

Footnote:

^[1] The Discharger shall monitor for the pollutants with Primary Maximum Contaminant Levels (MCLs), except for radionuclides. The MCLs can be found in Title 22 Table 64431-A (Inorganic Chemicals) of section 64431, Table 64433.2-A (Fluoride) of section 64433.2, and Table 64444-A (Organic Chemicals) of section 64444 of the California Code of Regulations. Priority pollutant monitoring conducted in accordance with the table above may be used to satisfy this monitoring requirement.

8.2. Effluent Monitoring Data

CTR No.	Parameter	Units	Maximum Concentration	Method Detection Limit	Test Method	Number of Samples
1	Antimony	µg/L				
2	Arsenic	µg/L				
3	Beryllium	µg/L				
4	Cadmium	µg/L				
5a	Chromium (III)	µg/L				
5b	Chromium (VI)	µg/L				
6	Copper	µg/L				
7	Lead	µg/L				
8	Mercury	µg/L				
9	Nickel	µg/L				
10	Selenium	µg/L				
11	Silver	µg/L				
12	Thallium	µg/L				
13	Zinc	µg/L				
14	Cyanide	µg/L				
15	Asbestos	fibers/L				
16	2,3,7,8-TCDD (Dioxin)	µg/L				
17	Acrolein	µg/L				
18	Acrylonitrile	µg/L				
19	Benzene	µg/L				
20	Bromoform	µg/L				
21	Carbon Tetrachloride	µg/L				
22	Chlorobenzene	µg/L				
23	Chlorodibromomethane	µg/L				
24	Chloroethane	µg/L				
25	2-Chloroethylvinyl ether	µg/L				
26	Chloroform	µg/L				
27	Dichlorobromomethane	µg/L				
28	1,1-Dichloroethane	µg/L				
29	1,2-Dichloroethane	µg/L				

CTR No.	Parameter	Units	Maximum Concentration	Method Detection Limit	Test Method	Number of Samples
30	1,1-Dichloroethylene	µg/L				
31	1,2-Dichloropropane	µg/L				
32	1,3-Dichloropropylene	µg/L				
33	Ethylbenzene	µg/L				
34	Methyl Bromide	µg/L				
35	Methyl Chloride	µg/L				
36	Methylene Chloride	µg/L				
37	1,1,2,2-Tetrachloroethane	µg/L				
38	Tetrachloroethylene	µg/L				
39	Toluene	µg/L				
40	1,2-Trans-Dichloroethylene	µg/L				
41	1,1,1-Trichloroethane	µg/L				
42	1,1,2-Trichloroethane	µg/L				
43	Trichloroethylene	µg/L				
44	Vinyl Chloride	µg/L				
45	2-Chlorophenol	µg/L				
46	2,4-Dichlorophenol	µg/L				
47	2,4-Dimethylphenol	µg/L				
48	2-Methyl- 4,6-Dinitrophenol	µg/L				
49	2,4-Dinitrophenol	µg/L				
50	2-Nitrophenol	µg/L				
51	4-Nitrophenol	µg/L				
52	3-Methyl 4-Chlorophenol	µg/L				
53	Pentachlorophenol	µg/L				
54	Phenol	µg/L				
55	2,4,6-Trichlorophenol	µg/L				
56	Acenaphthene	µg/L				
57	Acenaphthylene	µg/L				
58	Anthracene	µg/L				
59	Benzidine	µg/L				
60	Benzo(a)Anthracene	µg/L				
61	Benzo(a)Pyrene	µg/L				
62	Benzo(b)Fluoranthene	µg/L				
63	Benzo(ghi)Perylene	µg/L				
64	Benzo(k)Fluoranthene	µg/L				
65	Bis(2-Chloroethoxy)Methane	µg/L				
66	Bis(2-Chloroethyl)Ether	µg/L				
67	Bis(2-Chloroisopropyl)Ether	µg/L				
68	Bis(2-Ethylhexyl)Phthalate	µg/L				
69	4-Bromophenyl Phenyl Ether	µg/L				
70	Butylbenzyl Phthalate	µg/L				
71	2-Chloronaphthalene	µg/L				
72	4-Chlorophenyl Phenyl Ether	µg/L				
73	Chrysene	µg/L				

CTR No.	Parameter	Units	Maximum Concentration	Method Detection Limit	Test Method	Number of Samples
74	Dibenzo(a,h)Anthracene	µg/L				
75	1,2-Dichlorobenzene	µg/L				
76	1,3-Dichlorobenzene	µg/L				
77	1,4-Dichlorobenzene	µg/L				
78	3,3 Dichlorobenzidine	µg/L				
79	Diethyl Phthalate	µg/L				
80	Dimethyl Phthalate	µg/L				
81	Di-n-Butyl Phthalate	µg/L				
82	2,4-Dinitrotoluene	µg/L				
83	2,6-Dinitrotoluene	µg/L				
84	Di-n-Octyl Phthalate	µg/L				
85	1,2-Diphenylhydrazine	µg/L				
86	Fluoranthene	µg/L				
87	Fluorene	µg/L				
88	Hexachlorobenzene	µg/L				
89	Hexachlorobutadiene	µg/L				
90	Hexachlorocyclopentadiene	µg/L				
91	Hexachloroethane	µg/L				
92	Indeno(1,2,3-cd)Pyrene	µg/L				
93	Isophorone	µg/L				
94	Naphthalene	µg/L				
95	Nitrobenzene	µg/L				
96	N-Nitrosodimethylamine	µg/L				
97	N-Nitrosodi-n-Propylamine	µg/L				
98	N-Nitrosodiphenylamine	µg/L				
99	Phenanthrene	µg/L				
100	Pyrene	µg/L				
101	1,2,4-Trichlorobenzene	µg/L				
102	Aldrin	µg/L				
103	alpha-BHC	µg/L				
104	beta-BHC	µg/L				
105	gamma-BHC	µg/L				
106	delta-BHC	µg/L				
107	Chlordane (303d listed)	µg/L				
108	4,4'-DDT (303d listed)	µg/L				
109	4,4'-DDE	µg/L				
110	4,4'-DDD	µg/L				
111	Dieldrin (303d listed)	µg/L				
112	alpha-Endosulfan	µg/L				
113	beta-Endosulfan	µg/L				
114	Endosulfan Sulfate	µg/L				
115	Endrin	µg/L				
116	Endrin Aldehyde	µg/L				
117	Heptachlor	µg/L				
118	Heptachlor Epoxide	µg/L				
119-125	PCBs sum (303d listed)	µg/L				

CTR No.	Parameter	Units	Maximum Concentration	Method Detection Limit	Test Method	Number of Samples
126	Toxaphene	µg/L				
	Chlorine, Total Residual	mg/L				
	Salinity	µg/L				
	Cyanide	µg/L				
	Methyl Tertiary Butyl Ether	µg/L				
	TPH as gasoline	µg/L				
	TPH as diesel	µg/L				
	TPH as motor oil	µg/L				
	PFAS, all analytes	ng/L			EPA 1633	
	Municipal Supply Pollutants ^[1]	µg/L				

Footnote:

^[1] The Discharger shall monitor for the pollutants with Primary Maximum Contaminant Levels (MCLs), except for radionuclides. The MCLs can be found in Title 22 Table 64431-A (Inorganic Chemicals) of section 64431, Table 64433.2-A (Fluoride) of section 64433.2, and Table 64444-A (Organic Chemicals) of section 64444 of the California Code of Regulations. Priority pollutant monitoring conducted in accordance with the table above may be used to satisfy this monitoring requirement.

9. CERTIFIED ENGINEERING REPORT

Attach a certified engineering report signed and stamped by the Design Professional Engineer licensed to practice in California identified in section 4 above. The Certified Engineering Report shall include a location map, discharge flow path map, process flow diagram, and contingency plan as described Provision 6.3.3 of this Order. See section 10 below for additional details of the documents required as part of the Certified Engineering Report and NOI application package.

10. APPLICATION FEE AND MAILING INSTRUCTIONS

Submit application fee by check payable to “State Water Resources Control Board” to this address:

San Francisco Bay Regional Water Quality Control Board
Attn: NPDES Wastewater Division
1515 Clay Street, Suite 1400
Oakland, CA 94612

For the current fee, see the current Water Quality Fee Schedule (https://www.waterboards.ca.gov/resources/fees/water_quality/). Discharges authorized under the Groundwater General Permit fall under one of four classes. Classes 1, 2, and 3 are “Category 3” discharges for purposes of Water Code § 2200(b)(10), and Class 4 is a “Category 1” discharge for purposes of Water Code § 2200(b)(10).

Submit this form (with signature and attachments) via email to RB2-NPDES.GW@waterboards.ca.gov or as otherwise indicated at www.waterboards.ca.gov/sanfranciscobay/water_issues/programs/general_permits.shtml.

11. INSTRUCTIONS FOR NOTICE OF INTENT FORM

These instructions explain how to complete the NOI form. Submittal of an NOI indicates the Discharger's commitment to comply with the terms of this Order.

- 11.1. Discharger Information and Certification.** Enter the required information regarding the Discharger (i.e., the party responsible for the discharge) and certify the NOI. The person certifying the NOI must meet the requirements described in Attachment D section 5.2.2. Review these requirements carefully. Specific requirements apply to corporations, partnerships, sole proprietorships, and public agencies. Provide the treatment facility name, address, and contact person and their information.
- 11.2. Project Information.** Briefly describe the scope of the project (i.e., the activities to be covered by this Order), including site background information and project duration. Identify the discharge class applicable to the project (see section 1.1 of the Order).
- 11.3. Utility Information.** Provide information regarding the local utility agencies contacted for the proposed discharge. Note that Resolution 88-160, adopted by the Regional Water Board on October 19, 1988, urges groundwater dischargers to reclaim their effluent or discharge to a publicly-owned treatment works when reclamation is not technically or economically feasible.
- 11.4. Contact Information.** Provide the name and contact information of the duly authorized representative, design professional engineer, operations and maintenance professional engineer, and Discharger's consultancy. The design professional engineer is responsible for designing the groundwater treatment system and certifying any proposed changes to it. The operation and maintenance professional engineer is responsible for all operations and maintenance activities performed at the treatment facility. Both engineers must be licensed to practice in California. Exceptions to having a licensed operation and maintenance professional engineer overseeing operation and maintenance activities must be clearly explained, and the Discharger must describe how this exception would not compromise operation and maintenance activities at the treatment facility.
- 11.5. Billing Information.** Provide the billing contact information for the Discharger.
- 11.6. Discharge Location Information.** Identify the receiving water into which the discharge flows into and confirm whether access to the receiving water is restricted or unrestricted. Identify the salinity of receiving water. Identify all location points where the facility discharges wastewater and provide latitudes and longitudes for discharge locations (using decimal degrees with five decimal places). Briefly describe the discharge flow path from the effluent monitoring location to the outfall on the receiving water.
- 11.7. Treatment System Information.** Provide the groundwater treatment design capacity certified by the Design Professional Engineer identified in section 4

above. Narratively describe potential pollutants of concern in the discharge. Describe the type of water reclamation (e.g., dust suppression, soil compaction, landscape or agriculture irrigation, or industrial water supply) and expected discharge frequency. Note that this Order does not cover water reclamation consisting of recharge or reinjection. List all the treatment process units, specifying their quantities and general design details.

11.8. Monitoring Data. Existing dischargers must summarize influent and effluent monitoring data collected during the current permit term in an electronic spreadsheet (e.g., Microsoft Excel). New applicants must provide untreated groundwater monitoring data for all listed pollutants that are representative of the groundwater quality at the proposed project site.

11.9. Certified Engineering Report. The Certified Engineering Report is a comprehensive report detailing the process units of the groundwater extraction and treatment system. It certifies that the proposed treatment system will treat the discharge and meet the requirements in this Order. The report must be prepared by, or under the supervision of, a Professional Engineer licensed to practice in California, and signed and stamped by the same, as required by the California Business and Profession Code section 6735. The report must provide site background information and briefly summarize environmental investigations concerning groundwater contamination at the site, if any. The description of the treatment system may include dewatering wells, settling tanks, particulate filters, carbon filters, chemical additives, etc. Applicants must include safety data sheets for any chemical additive proposed for use. Additionally, the report must include:

11.9.1. Location Map. Topographic map showing the legal facility boundaries, treatment system location, effluent monitoring location, and storm drain entry point location (if applicable).

11.9.2. Discharge Flow Path Map. An aerial map or satellite image illustrating the proposed path of the discharge from the effluent monitoring location to the outfall on the receiving water. All applicable topographic features, including streets and receiving waters, must be identified on the map.

11.9.3. Process Flow Diagram. A diagram showing the layout of the treatment process units, monitoring locations (e.g., influent, midstream [see Attachment E Table E-1], and effluent), and process wastewater flow from the intake to the exit point of the treatment system. An example of such a diagram is below:

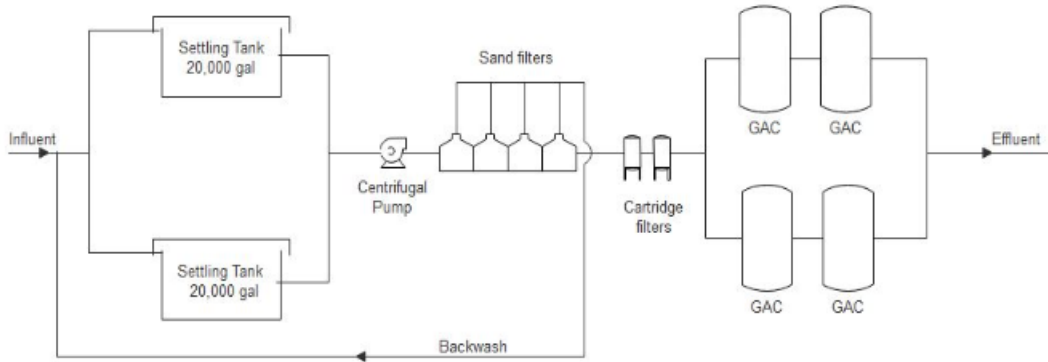

11.9.4. Contingency Plan. Provide a plan that describes the procedures in place to ensure that the Discharger's facility remains in, or are rapidly returned to, operation in the event of equipment failure or another type of emergency, as described in Provision 6.3.3 of this Order.

ATTACHMENT C– NOTICE OF TERMINATION FORM

This **NOTICE OF TERMINATION** form shall be completed to terminate coverage under the Groundwater General Permit, NPDES Permit CAG912002.

This form shall be signed in accordance with Attachment D section 5.2 and sent via email to RB2-NPDES.GW@waterboards.ca.gov (please copy the permit case manager indicated at https://www.waterboards.ca.gov/sanfranciscobay/water_issues/programs/general_permit_s.html).

Company / Owner Name (Discharger)	CIWQS Place ID	
Facility Street Address	City	State CA
Last Date of Discharge		
Contact Person Name	Title	
Email	Phone Number	
Signature	Date	

Check here if the Discharger has performed PFAS treatment and is including the PFAS Monitoring Summary Report with this form. See MRP section 6.4 for details.

ATTACHMENT D – STANDARD PROVISIONS**CONTENTS**

1. STANDARD PROVISIONS – PERMIT COMPLIANCE	D-2
1.1. Duty to Comply.....	D-2
1.2. Need to Halt or Reduce Activity Not a Defense	D-2
1.3. Duty to Mitigate	D-2
1.4. Proper Operation and Maintenance	D-2
1.5. Property Rights	D-2
1.6. Inspection and Entry	D-3
1.7. Bypass	D-3
1.8. Upset.....	D-5
2. STANDARD PROVISIONS – PERMIT ACTION	D-5
2.1. General	D-5
2.2. Duty to Reapply.....	D-6
2.3. Transfers	D-6
3. STANDARD PROVISIONS – MONITORING	D-6
4. STANDARD PROVISIONS – RECORDS.....	D-7
5. STANDARD PROVISIONS – REPORTING	D-7
5.1. Duty to Provide Information.....	D-7
5.2. Signatory and Certification Requirements.....	D-8
5.3. Monitoring Reports.....	D-9
5.4. Compliance Schedules	D-10
5.5. Twenty-Four Hour Reporting.....	D-10
5.6. Planned Changes.....	D-11
5.7. Anticipated Noncompliance.....	D-11
5.8. Other Noncompliance	D-11
5.9. Other Information	D-12
5.10. Initial Recipient for Electronic Reporting Data.....	D-12
6. STANDARD PROVISIONS – ENFORCEMENT	D-12
7. ADDITIONAL PROVISIONS – NOTIFICATION LEVELS	D-12
7.1. Non-Municipal Facilities	D-12
7.2. Publicly Owned Treatment Works (POTWs).....	D-13

ATTACHMENT D – STANDARD PROVISIONS

1. STANDARD PROVISIONS – PERMIT COMPLIANCE

1.1. Duty to Comply

- 1.1.1. The Discharger must comply with all of the terms, requirements, and conditions of this Order. Any noncompliance constitutes a violation of the Clean Water Act (CWA) and the California Water Code and is grounds for enforcement action; permit termination, revocation and reissuance, or modification; denial of a permit renewal application; or a combination thereof. (40 C.F.R. § 122.41(a); Wat. Code, §§ 13261, 13263, 13265, 13268, 13000, 13001, 13304, 13350, 13385.)
- 1.1.2. The Discharger shall comply with effluent standards or prohibitions established under CWA section 307(a) for toxic pollutants within the time provided in the regulations that establish these standards or prohibitions, even if this Order has not yet been modified to incorporate the requirement. (40 C.F.R. § 122.41(a)(1).)

1.2. Need to Halt or Reduce Activity Not a Defense

It shall not be a defense for a Discharger in an enforcement action that it would have been necessary to halt or reduce the permitted activity in order to maintain compliance with the conditions of this Order. (40 C.F.R. § 122.41(c).)

1.3. Duty to Mitigate

The Discharger shall take all reasonable steps to minimize or prevent any discharge in violation of this Order that has a reasonable likelihood of adversely affecting human health or the environment. (40 C.F.R. § 122.41(d).)

1.4. Proper Operation and Maintenance

The Discharger shall at all times properly operate and maintain all facilities and systems of treatment and control (and related appurtenances) that are installed or used by the Discharger to achieve compliance with the conditions of this Order. Proper operation and maintenance also includes adequate laboratory controls and appropriate quality assurance procedures. This provision requires the operation of backup or auxiliary facilities or similar systems that are installed by a Discharger only when necessary to achieve compliance with the conditions of this Order. (40 C.F.R. § 122.41(e).)

1.5. Property Rights

- 1.5.1. This Order does not convey any property rights of any sort or any exclusive privileges. (40 C.F.R. § 122.41(g).)

- 1.5.2. The issuance of this Order does not authorize any injury to persons or property or invasion of other private rights, or any infringement of state or local law or regulations. (40 C.F.R. § 122.5(c).)

1.6. Inspection and Entry

The Discharger shall allow the Regional Water Board, State Water Board, U.S. EPA, and/or their authorized representatives (including an authorized contractor acting as their representative), upon the presentation of credentials and other documents, as may be required by law, to (33 U.S.C. § 1318(a)(4)(B); 40 C.F.R. § 122.41(i); Wat. Code, §§ 13267, 13383):

- 1.6.1. Enter upon the Discharger's premises where a regulated facility or activity is located or conducted, or where records are kept under the conditions of this Order (33 U.S.C. § 1318(a)(4)(B)(i); 40 C.F.R. § 122.41(i)(1); Wat. Code, §§ 13267, 13383);
- 1.6.2. Have access to and copy, at reasonable times, any records that must be kept under the conditions of this Order (33 U.S.C. § 1318(a)(4)(B)(ii); 40 C.F.R. § 122.41(i)(2); Wat. Code, §§ 13267, 13383);
- 1.6.3. Inspect and photograph, at reasonable times, any facilities, equipment (including monitoring and control equipment), practices, or operations regulated or required under this Order (33 U.S.C. § 1318(a)(4)(B)(ii); 40 C.F.R. § 122.41(i)(3); Wat. Code, §§ 13267, 13383); and
- 1.6.4. Sample or monitor, at reasonable times, for the purposes of ensuring Order compliance or as otherwise authorized by the CWA or the Water Code, any substances or parameters at any location. (33 U.S.C. § 1318(a)(4)(B); 40 C.F.R. § 122.41(i)(4); Wat. Code, §§ 13267, 13383.)

1.7. Bypass

1.7.1. Definitions

- 1.7.1.1. "Bypass" means the intentional diversion of waste streams from any portion of a treatment facility. (40 C.F.R. § 122.41(m)(1)(i).)
- 1.7.1.2. "Severe property damage" means substantial physical damage to property; damage to the treatment facilities, which causes them to become inoperable; or substantial and permanent loss of natural resources that can reasonably be expected to occur in the absence of a bypass. Severe property damage does not mean economic loss caused by delays in production. (40 C.F.R. § 122.41(m)(1)(ii).)
- 1.7.2. **Bypass not exceeding limitations.** The Discharger may allow any bypass to occur that does not cause exceedances of effluent limitations, but only if it is for essential maintenance to ensure efficient operation. These bypasses are not

subject to the provisions listed in Standard Provisions – Permit Compliance sections 1.7.3, 1.7.4, and 1.7.5 below. (40 C.F.R. § 122.41(m)(2).)

- 1.7.3. **Prohibition of bypass.** Bypass is prohibited, and the Regional Water Board may take enforcement action against a Discharger for bypass, unless (40 C.F.R. § 122.41(m)(4)(i)):
 - 1.7.3.1. Bypass was unavoidable to prevent loss of life, personal injury, or severe property damage (40 C.F.R. § 122.41(m)(4)(i)(A));
 - 1.7.3.2. There were no feasible alternatives to the bypass, such as the use of auxiliary treatment facilities, retention of untreated wastes, or maintenance during normal periods of equipment downtime. This condition is not satisfied if adequate back up equipment should have been installed in the exercise of reasonable engineering judgment to prevent a bypass that occurred during normal periods of equipment downtime or preventive maintenance (40 C.F.R. § 122.41(m)(4)(i)(B)); and
 - 1.7.3.3. The Discharger submitted notice to the Regional Water Board as required under Standard Provisions – Permit Compliance section 1.7.5 below. (40 C.F.R. § 122.41(m)(4)(i)(C).)
- 1.7.4. **Approval.** The Regional Water Board may approve an anticipated bypass, after considering its adverse effects, if the Regional Water Board determines that it will meet the three conditions listed in Standard Provisions – Permit Compliance section 1.7.3 above. (40 C.F.R. § 122.41(m)(4)(ii).)
- 1.7.5. **Notice**
 - 1.7.5.1. **Anticipated bypass.** If the Discharger knows in advance of the need for a bypass, it shall submit prior notice, if possible, at least 10 days before the date of the bypass. The notice shall be sent to the Regional Water Board. As of December 21, 2025, a notice shall also be submitted electronically to the initial recipient defined in Standard Provisions – Reporting section 5.10 below. Notices shall comply with 40 C.F.R. part 3, 40 C.F.R. section 122.22, and 40 C.F.R. part 127. (40 C.F.R. § 122.41(m)(3)(i).)
 - 1.7.5.2. **Unanticipated bypass.** The Discharger shall submit a notice of an unanticipated bypass as required in Standard Provisions – Reporting section 5.5 below (24-hour notice). The notice shall be sent to the Regional Water Board. As of December 21, 2025, a notice shall also be submitted electronically to the initial recipient defined in Standard Provisions – Reporting section 5.10 below. Notices shall comply with 40 C.F.R. part 3, 40 C.F.R. section 122.22, and 40 C.F.R. part 127. (40 C.F.R. § 122.41(m)(3)(ii).)

1.8. Upset

Upset means an exceptional incident in which there is unintentional and temporary noncompliance with technology-based permit effluent limitations because of factors beyond the reasonable control of the Discharger. An upset does not include noncompliance to the extent caused by operational error, improperly designed treatment facilities, inadequate treatment facilities, lack of preventive maintenance, or careless or improper operation. (40 C.F.R. § 122.41(n)(1).)

- 1.8.1. **Effect of an upset.** An upset constitutes an affirmative defense to an action brought for noncompliance with such technology-based permit effluent limitations if the requirements of Standard Provisions – Permit Compliance section 1.8.2 below are met. No determination made during administrative review of claims that noncompliance was caused by upset, and before an action for noncompliance, is final administrative action subject to judicial review. (40 C.F.R. § 122.41(n)(2).)
- 1.8.2. **Conditions necessary for a demonstration of upset.** A Discharger who wishes to establish the affirmative defense of upset shall demonstrate, through properly signed, contemporaneous operating logs or other relevant evidence that (40 C.F.R. § 122.41(n)(3)):
 - 1.8.2.1. An upset occurred and that the Discharger can identify the cause(s) of the upset (40 C.F.R. § 122.41(n)(3)(i));
 - 1.8.2.2. The permitted facility was, at the time, being properly operated (40 C.F.R. § 122.41(n)(3)(ii));
 - 1.8.2.3. The Discharger submitted notice of the upset as required in Standard Provisions – Reporting section 5.5.2.2 below (24-hour notice) (40 C.F.R. § 122.41(n)(3)(iii)); and
 - 1.8.2.4. The Discharger complied with any remedial measures required under Standard Provisions – Permit Compliance section 1.3 above. (40 C.F.R. § 122.41(n)(3)(iv).)
- 1.8.3. **Burden of proof.** In any enforcement proceeding, the Discharger seeking to establish the occurrence of an upset has the burden of proof. (40 C.F.R. § 122.41(n)(4).)

2. STANDARD PROVISIONS – PERMIT ACTION

2.1. General

This Order may be modified, revoked and reissued, or terminated for cause. The filing of a request by the Discharger for modification, revocation and reissuance, or termination, or a notification of planned changes or anticipated noncompliance does not stay any Order condition. (40 C.F.R. § 122.41(f).)

2.2. Duty to Reapply

If the Discharger wishes to continue an activity regulated by this Order after the expiration date of this Order, the Discharger must apply for and obtain a new permit. (40 C.F.R. § 122.41(b).)

2.3. Transfers

This Order is not transferable to any person except after notice to the Regional Water Board. The Regional Water Board may require modification or revocation and reissuance of the Order to change the name of the Discharger and incorporate such other requirements as may be necessary under the CWA and Water Code. (40 C.F.R. §§ 122.41(l)(3), 122.61.)

3. STANDARD PROVISIONS – MONITORING

- 3.1. Samples and measurements taken for the purpose of monitoring shall be representative of the monitored activity. (40 C.F.R. § 122.41(j)(1).)
- 3.2. Monitoring must be conducted according to test procedures approved under 40 C.F.R. part 136 for the analyses of pollutants unless another method is required under 40 C.F.R. chapter 1, subchapter N. Monitoring must be conducted according to sufficiently sensitive test methods approved under 40 C.F.R. part 136 for the analysis of pollutants or pollutant parameters or as required under 40 C.F.R. chapter 1, subchapter N. For the purposes of this paragraph, a method is sufficiently sensitive when:
 - 3.2.1. The method minimum level (ML) is at or below the level of the most stringent effluent limitation established in the permit for the measured pollutant or pollutant parameter, and either the method ML is at or below the level of the most stringent applicable water quality criterion for the measured pollutant or pollutant parameter or the method ML is above the applicable water quality criterion but the amount of the pollutant or pollutant parameter in the facility's discharge is high enough that the method detects and quantifies the level of the pollutant or pollutant parameter in the discharge; or
 - 3.2.2. The method has the lowest ML of the analytical methods approved under 40 C.F.R. part 136 or required under 40 C.F.R. chapter 1, subchapter N, for the measured pollutant or pollutant parameter.
- 3.3. In the case of pollutants or pollutant parameters for which there are no approved methods under 40 C.F.R. part 136 or otherwise required under 40 C.F.R. chapter 1, subchapter N, monitoring must be conducted according to a test procedure specified in this Order for such pollutants or pollutant parameters. (40 C.F.R. §§ 122.21(e)(3), 122.41(j)(4), 122.44(i)(1)(iv).)

4. STANDARD PROVISIONS – RECORDS

4.1. The Discharger shall retain records of all monitoring information, including all calibration and maintenance records and all original strip chart recordings for continuous monitoring instrumentation, copies of all reports required by this Order, and records of all data used to complete the application for this Order, for a period of at least three (3) years from the date of the sample, measurement, report, or application. This period may be extended by request of the Regional Water Board Executive Officer at any time. (40 C.F.R. § 122.41(j)(2).)

4.2. Records of monitoring information shall include:

4.2.1. The date, exact place, and time of sampling or measurements (40 C.F.R. § 122.41(j)(3)(i));

4.2.2. The individual(s) who performed the sampling or measurements (40 C.F.R. § 122.41(j)(3)(ii));

4.2.3. The date(s) analyses were performed (40 C.F.R. § 122.41(j)(3)(iii));

4.2.4. The individual(s) who performed the analyses (40 C.F.R. § 122.41(j)(3)(iv));

4.2.5. The analytical techniques or methods used (40 C.F.R. § 122.41(j)(3)(v)); and

4.2.6. The results of such analyses. (40 C.F.R. § 122.41(j)(3)(vi).)

4.3. Claims of confidentiality for the following information will be denied (40 C.F.R. § 122.7(b)):

4.3.1. The name and address of any permit applicant or Discharger (40 C.F.R. § 122.7(b)(1)); and

4.3.2. Permit applications and attachments, permits, and effluent data. (40 C.F.R. § 122.7(b)(2).)

5. STANDARD PROVISIONS – REPORTING

5.1. Duty to Provide Information

The Discharger shall furnish to the Regional Water Board, State Water Board, or U.S. EPA within a reasonable time, any information that the Regional Water Board, State Water Board, or U.S. EPA may request to determine whether cause exists for modifying, revoking and reissuing, or terminating this Order or to determine compliance with this Order. Upon request, the Discharger shall also furnish to the Regional Water Board, State Water Board, or U.S. EPA copies of records required to be kept by this Order. (40 C.F.R. § 122.41(h); Wat. Code, §§ 13267, 13383.)

5.2. Signatory and Certification Requirements

- 5.2.1. All applications, reports, or information submitted to the Regional Water Board, State Water Board, and/or U.S. EPA shall be signed and certified in accordance with Standard Provisions – Reporting sections 5.2.2, 5.2.3, 5.2.4, 5.2.5, and 5.2.6 below. (40 C.F.R. § 122.41(k).)
- 5.2.2. For a corporation, all permit applications shall be signed by a responsible corporate officer. For the purpose of this section, a responsible corporate officer means: (1) a president, secretary, treasurer, or vice-president of the corporation in charge of a principal business function, or any other person who performs similar policy- or decision-making functions for the corporation, or (2) the manager of one or more manufacturing, production, or operating facilities, provided the manager is authorized to make management decisions that govern the operation of the regulated facility, including having the explicit or implicit duty of making major capital investment recommendations, and initiating and directing other comprehensive measures to ensure long term environmental compliance with environmental laws and regulations; the manager can ensure that the necessary systems are established or actions taken to gather complete and accurate information for permit application requirements; and where authority to sign documents has been assigned or delegated to the manager in accordance with corporate procedures. (40 C.F.R. § 122.22(a)(1).)

For a partnership or sole proprietorship, all permit applications shall be signed by a general partner or the proprietor, respectively. (40 C.F.R. § 122.22(a)(2).)

For a municipal, state, federal, or other public agency, all permit applications shall be signed by either a principal executive officer or ranking elected official. For purposes of this provision, a principal executive officer of a federal agency includes (1) the chief executive officer of the agency, or (2) a senior executive officer having responsibility for the overall operations of a principal geographic unit of the agency (e.g., Regional Administrators of U.S. EPA). (40 C.F.R. § 122.22(a)(3).)

- 5.2.3. All reports required by this Order and other information requested by the Regional Water Board, State Water Board, or U.S. EPA shall be signed by a person described in Standard Provisions – Reporting section 5.2.2 above, or by a duly authorized representative of that person. A person is a duly authorized representative only if:
- 5.2.3.1. The authorization is made in writing by a person described in Standard Provisions – Reporting section 5.2.2 above (40 C.F.R. § 122.22(b)(1));
- 5.2.3.2. The authorization specifies either an individual or a position having responsibility for the overall operation of the regulated facility or activity, such as the position of plant manager, operator of a well or a well field, superintendent, position of equivalent responsibility, or an individual or

position having overall responsibility for environmental matters for the company. (A duly authorized representative may thus be either a named individual or any individual occupying a named position.) (40 C.F.R. § 122.22(b)(2)); and

- 5.2.3.3. The written authorization is submitted to the Regional Water Board and State Water Board. (40 C.F.R. § 122.22(b)(3).)
- 5.2.4. If an authorization under Standard Provisions – Reporting section 5.2.3 above is no longer accurate because a different individual or position has responsibility for the overall operation of the facility, a new authorization satisfying the requirements of Standard Provisions – Reporting section 5.2.3 above must be submitted to the Regional Water Board and State Water Board prior to or together with any reports, information, or applications to be signed by an authorized representative. (40 C.F.R. § 122.22(c).)
- 5.2.5. Any person signing a document under Standard Provisions – Reporting section 5.2.2 or 5.2.3 above shall make the following certification:

“I certify under penalty of law that this document and all attachments were prepared under my direction or supervision in accordance with a system designed to assure that qualified personnel properly gather and evaluate the information submitted. Based on my inquiry of the person or persons who manage the system or those persons directly responsible for gathering the information, the information submitted is, to the best of my knowledge and belief, true, accurate, and complete. I am aware that there are significant penalties for submitting false information, including the possibility of fine and imprisonment for knowing violations.” (40 C.F.R. § 122.22(d).)
- 5.2.6. Any person providing the electronic signature for documents described in Standard Provisions – Reporting sections 5.2.1, 5.2.2, or 5.2.3 that are submitted electronically shall meet all relevant requirements of Standard Provisions – Reporting section 5.2, and shall ensure that all relevant requirements of 40 C.F.R. part 3 (Cross-Media Electronic Reporting) and 40 C.F.R. part 127 (NPDES Electronic Reporting Requirements) are met for that submission. (40 C.F.R. § 122.22(e).)

5.3. Monitoring Reports

- 5.3.1. Monitoring results shall be reported at the intervals specified in the Monitoring and Reporting Program (Attachment E) in this Order. (40 C.F.R. § 122.41(l)(4).)
- 5.3.2. Monitoring results must be reported on a Discharge Monitoring Report (DMR) form or forms provided or specified by the Regional Water Board or State Water Board. All reports and forms must be submitted electronically to the initial recipient defined in Standard Provisions – Reporting section 5.10 and comply

with 40 C.F.R. part 3, 40 C.F.R. section 122.22, and 40 C.F.R. part 127. (40 C.F.R. § 122.41(l)(4)(i).)

- 5.3.3. If the Discharger monitors any pollutant more frequently than required by this Order using test procedures approved under 40 C.F.R. part 136, or another method required for an industry-specific waste stream under 40 C.F.R. chapter 1, subchapter N, the results of such monitoring shall be included in the calculation and reporting of the data submitted in the DMR or reporting form specified by the Regional Water Board or State Water Board. (40 C.F.R. § 122.41(l)(4)(ii).)
- 5.3.4. Calculations for all limitations that require averaging of measurements shall utilize an arithmetic mean unless otherwise specified in this Order. (40 C.F.R. § 122.41(l)(4)(iii).)

5.4. Compliance Schedules

Reports of compliance or noncompliance with, or any progress reports on, interim and final requirements contained in any compliance schedule of this Order shall be submitted no later than 14 days following each schedule date. (40 C.F.R. § 122.41(l)(5).)

5.5. Twenty-Four Hour Reporting

- 5.5.1. The Discharger shall report any noncompliance that may endanger health or the environment. Any information shall be provided orally within 24 hours from the time the Discharger becomes aware of the circumstances. A written report shall also be provided within five (5) days of the time the Discharger becomes aware of the circumstances. The report shall contain a description of the noncompliance and its cause; the period of noncompliance, including exact dates and times, and, if the noncompliance has not been corrected, the anticipated time it is expected to continue; and steps taken or planned to reduce, eliminate, and prevent reoccurrence of the noncompliance.

For noncompliance related to combined sewer overflows, sanitary sewer overflows, or bypass events, these reports must include the data described above (with the exception of time of discovery) as well as the type of event (i.e., combined sewer overflow, sanitary sewer overflow, or bypass event), type of overflow structure (e.g., manhole, combined sewer overflow outfall), discharge volume untreated by the treatment works treating domestic sewage, types of human health and environmental impacts of the event, and whether the noncompliance was related to wet weather.

As of December 21, 2025, all reports related to combined sewer overflows, sanitary sewer overflows, or bypass events must be submitted to the Regional Water Board and must be submitted electronically to the initial recipient defined in Standard Provisions – Reporting section 5.10 The reports shall comply with 40 C.F.R. part 3, 40 C.F.R. section 122.22, and 40 C.F.R. part 127. The

Regional Water Board may also require the Discharger to electronically submit reports not related to combined sewer overflows, sanitary sewer overflows, or bypass events under this section. (40 C.F.R. § 122.41(l)(6)(i).)

5.5.2. The following shall be included as information that must be reported within 24 hours:

5.5.2.1. Any unanticipated bypass that exceeds any effluent limitation in this Order. (40 C.F.R. § 122.41(l)(6)(ii)(A).)

5.5.2.2. Any upset that exceeds any effluent limitation in this Order. (40 C.F.R. § 122.41(l)(6)(ii)(B).)

5.5.3. The Regional Water Board may waive the above required written report on a case-by-case basis if an oral report has been received within 24 hours. (40 C.F.R. § 122.41(l)(6)(ii)(B).)

5.6. Planned Changes

The Discharger shall give notice to the Regional Water Board as soon as possible of any planned physical alterations or additions to the permitted facility. Notice is required under this provision only when (40 C.F.R. § 122.41(l)(1)):

5.6.1. The alteration or addition to a permitted facility may meet one of the criteria for determining whether a facility is a new source in 40 C.F.R. section 122.29(b) (40 C.F.R. § 122.41(l)(1)(i)); or

5.6.2. The alteration or addition could significantly change the nature or increase the quantity of pollutants discharged. This notification applies to pollutants that are not subject to effluent limitations in this Order unless the discharge is an existing manufacturing, commercial, mining, or silvicultural discharge as referenced in 40 C.F.R. section 122.42(a). (40 C.F.R. § 122.41(l)(1)(ii).) If the discharge is an existing manufacturing, commercial, mining, or silvicultural discharge as referenced in 40 C.F.R. section 122.42(a), this notification applies to pollutants that are subject neither to effluent limitations in this Order nor to notification requirements under 40 C.F.R. section 122.42(a)(1) (see Additional Provisions – Notification Levels section 7.1.1). (40 C.F.R. § 122.41(l)(1)(ii).)

5.7. Anticipated Noncompliance

The Discharger shall give advance notice to the Regional Water Board of any planned changes in the permitted facility or activity that may result in noncompliance with this Order's requirements. (40 C.F.R. § 122.41(l)(2).)

5.8. Other Noncompliance

The Discharger shall report all instances of noncompliance not reported under Standard Provisions – Reporting sections 5.3, 5.4, and 5.5 above at the time

monitoring reports are submitted. The reports shall contain the information listed in Standard Provision – Reporting section 5.5 above. For noncompliance related to combined sewer overflows, sanitary sewer overflows, or bypass events, these reports shall contain the information described in Standard Provision – Reporting section 5.5 and the applicable required data in appendix A to 40 C.F.R. part 127. The Regional Water Board may also require the Discharger to electronically submit reports not related to combined sewer overflows, sanitary sewer overflows, or bypass events under this section. (40 C.F.R. § 122.41(l)(7).)

5.9. Other Information

When the Discharger becomes aware that it failed to submit any relevant facts in a permit application, or submitted incorrect information in a permit application or in any report to the Regional Water Board, State Water Board, or U.S. EPA, the Discharger shall promptly submit such facts or information. (40 C.F.R. § 122.41(l)(8).)

5.10. Initial Recipient for Electronic Reporting Data

The owner, operator, or duly authorized representative is required to electronically submit NPDES information specified in appendix A to 40 C.F.R. part 127 to the initial recipient defined in 40 C.F.R. section 127.2(b). U.S. EPA will identify and publish the list of initial recipients on its website and in the Federal Register, by state and by NPDES data group [see 40 C.F.R. section 127.2(c)]. U.S. EPA will update and maintain this list. (40 C.F.R. § 122.41(l)(9).)

6. STANDARD PROVISIONS – ENFORCEMENT

The Regional Water Board is authorized to enforce the terms of this permit under several provisions of the Water Code, including, but not limited to, Water Code sections 13268, 13385, 13386, and 13387.

7. ADDITIONAL PROVISIONS – NOTIFICATION LEVELS

7.1. Non-Municipal Facilities

Existing manufacturing, commercial, mining, and silvicultural Dischargers shall notify the Regional Water Board as soon as they know or have reason to believe (40 C.F.R. § 122.42(a)):

7.1.1. That any activity has occurred or will occur that would result in the discharge, on a routine or frequent basis, of any toxic pollutant that is not limited in this Order, if that discharge will exceed the highest of the following “notification levels” (40 C.F.R. § 122.42(a)(1)):

7.1.1.1. 100 micrograms per liter ($\mu\text{g/L}$) (40 C.F.R. § 122.42(a)(1)(i));

- 7.1.1.2. 200 µg/L for acrolein and acrylonitrile; 500 µg/L for 2,4 dinitrophenol and 2-methyl 4,6 dinitrophenol; and 1 milligram per liter (mg/L) for antimony (40 C.F.R. § 122.42(a)(1)(ii));
 - 7.1.1.3. Five (5) times the maximum concentration reported for that pollutant in the Report of Waste Discharge (40 C.F.R. § 122.42(a)(1)(iii)); or
 - 7.1.1.4. The level established by the Regional Water Board in accordance with 40 C.F.R. section 122.44(f). (40 C.F.R. § 122.42(a)(1)(iv).)
- 7.1.2. That any activity has occurred or will occur that would result in the discharge, on a non-routine or infrequent basis, of any toxic pollutant that is not limited in this Order, if that discharge will exceed the highest of the following "notification levels" (40 C.F.R. § 122.42(a)(2)):
- 7.1.2.1. 500 micrograms per liter (µg/L) (40 C.F.R. § 122.42(a)(2)(i));
 - 7.1.2.2. 1 milligram per liter (mg/L) for antimony (40 C.F.R. § 122.42(a)(2)(ii));
 - 7.1.2.3. Ten (10) times the maximum concentration reported for that pollutant in the Report of Waste Discharge (40 C.F.R. § 122.42(a)(2)(iii)); or
 - 7.1.2.4. The level established by the Regional Water Board in accordance with 40 C.F.R. section 122.44(f). (40 C.F.R. § 122.42(a)(2)(iv).)

7.2. Publicly Owned Treatment Works (POTWs)

- 7.2.1. All POTWs shall provide adequate notice to the Regional Water Board of any new introduction of pollutants into the POTW from an indirect discharger that would be subject to CWA sections 301 or 306 if it were directly discharging those pollutants (40 C.F.R. § 122.42(b)(1)).
- 7.2.2. All POTWs shall provide adequate notice to the Regional Water Board of any substantial change in the volume or character of pollutants being introduced into that POTW by a source introducing pollutants into the POTW at the time of adoption of this Order. (40 C.F.R. § 122.42(b)(2).)
- 7.2.3. Adequate notice shall include information on the quality and quantity of effluent introduced into the POTW as well as any anticipated impact of the change on the quantity or quality of effluent to be discharged from the POTW. (40 C.F.R. § 122.42(b)(3).)

ATTACHMENT E – MONITORING AND REPORTING PROGRAM

CONTENTS

1. GENERAL MONITORING PROVISIONS	E-2
2. MONITORING LOCATIONS.....	E-2
3. MONITORING REQUIREMENTS	E-3
4. RECEIVING WATER MONITORING REQUIREMENTS	E-9
5. OTHER MONITORING REQUIREMENTS	E-10
6. REPORTING REQUIREMENTS.....	E-11

TABLES

TABLE E-1. MONITORING LOCATIONS	E-3
TABLE E-2. MINIMUM MONITORING FOR CLASSES 1, 2, AND 3.....	E-3
TABLE E-3. MINIMUM MONITORING FOR CLASS 4	E-4
TABLE E-4. MINIMUM MONITORING FOR PFAS.....	E-9
TABLE E-5. MONITORING PERIODS	E-14

ATTACHMENT E – MONITORING AND REPORTING PROGRAM

Clean Water Act (CWA) section 308 and 40 C.F.R. sections 122.41(h), (j)-(l), 122.44(i), and 122.48 require that all NPDES permits specify monitoring and reporting requirements. Water Code section 13383 also authorizes the Regional Water Board to establish monitoring, inspection, entry, reporting, and recordkeeping requirements. This Monitoring and Reporting Program (MRP) establishes monitoring, reporting, and recordkeeping requirements that implement the federal and State laws and regulations.

1. GENERAL MONITORING PROVISIONS

- 1.1. The Discharger shall comply with this MRP. The Executive Officer may amend this MRP pursuant to 40 C.F.R. section 122.63.
- 1.2. The Discharger shall conduct all monitoring in accordance with Attachment D section 3. Equivalent test methods must be more sensitive than those specified in 40 C.F.R. section 136 and must be specified in this permit or the Discharger's Authorization to Discharge.
- 1.3. For the analysis of monitoring samples, the Discharger shall use laboratories certified by the State Water Resources Control Board (State Water Board) in accordance with Water Code section 13176 and shall obtain quality assurance/quality control data with laboratory reports. For any onsite field tests (e.g., pH) analyzed by a noncertified laboratory, the Discharger shall implement a Quality Assurance-Quality Control Program. The Discharger shall keep a manual onsite containing the steps followed in this program and shall demonstrate sufficient capability to adequately perform these field tests (e.g., qualified and trained employees, properly calibrated and maintained field instruments). The program shall conform to U.S. EPA guidelines or other approved procedures.
- 1.4. If required by U.S. EPA, the Discharger shall ensure that the results of the Discharge Monitoring Report-Quality Assurance (DMR-QA) Study or most recent Water Pollution Performance Evaluation Study are submitted annually to the State Water Board to the DMR-QA Officer via email at QualityAssurance@waterboards.ca.gov, or at the following address:

State Water Resources Control Board
Quality Assurance Program Officer
Office of Information Management and Analysis
1001 I Street
Sacramento, CA 95814

2. MONITORING LOCATIONS

The Discharger shall establish the following monitoring locations to demonstrate compliance with this Order:

Table E-1. Monitoring Locations

Monitoring Location Type	Monitoring Location ^[1]	Monitoring Location Description
Influent	INF-00n	Any point immediately prior to the treatment system.
Midstream	MID-00n	Any point in the waste stream prior to the last unit or vessel within the last treatment stage using adsorptive media (applicable only to PFAS treatment systems using GAC or ion exchange technologies) used to assess breakthrough. The Executive Officer may establish additional midstream monitoring locations with the Authorization to Discharge, as needed.
Effluent	EFF-00n	Any point in the discharge line immediately following the treatment system.
Receiving Water	RSW-00n	Any point in the receiving water immediately downstream of the outfall.

Footnote:

^[1] "n" is the number designation of the corresponding monitoring location. For example, if there are two effluent monitoring locations, the effluent monitoring locations shall be named EFF-001 and EFF-002.

3. MONITORING REQUIREMENTS

3.1. Classes 1, 2, and 3: Dischargers shall monitor influent, effluent, and receiving water at monitoring locations established in accordance with Table E-1 as follows:

TABLE E-2. Minimum Monitoring for Classes 1, 2, and 3

Parameter	Unit	Suggested Analytical Test Method	Sample Type	Influent	Effluent Water	Receiving Water
Flow	gpm	-	Continuous	-	Continuous	-
pH	standard units	EPA 150.2	Grab	-	Startup Phase (SP) ^[1] , then 1/Month	-
Chlorine, Total Residual ^[2]	mg/L	Field Kit, EPA 330 or SM4500-Cl	Grab	SP	SP, then 1/Month	-
Turbidity	NTU	EPA 180.1 or SM 2130B	Grab	-	SP, then 1/Month	SP
Total Dissolved Solids	mg/L	-	Grab		SP, then 1/Quarter	SP
Salinity	‰	-	Grab		SP, then 1/Quarter	SP
Cadmium, Total Recoverable	µg/L	EPA 200.9 or EPA 200.8	Grab	SP	SP, then 1/Quarter	-
Copper, Total Recoverable	µg/L	EPA 200.9 or EPA 200.8	Grab	SP	SP, then 1/Quarter	-

Parameter	Unit	Suggested Analytical Test Method	Sample Type	Influent	Effluent Water	Receiving Water
Lead, Total Recoverable	µg/L	EPA 200.9 or EPA 200.8	Grab	SP	SP, then 1/Quarter	-
Nickel, Total Recoverable	µg/L	EPA 200.9 or EPA 200.8	Grab	SP	SP, then 1/Quarter	-
Selenium, Total Recoverable	µg/L	EPA 200.9 or EPA 200.8	Grab	SP	SP, then Once	-
TPH as Gasoline ^[3]	µg/L	EPA 8260B Modified or EPA 8015B Modified	Grab	SP	SP, then Once	-
TPH as Diesel ^[3]	µg/L	EPA 8015B Modified	Grab	SP	SP, then Once	-
TPH as Motor Oil ^[3]	µg/L	EPA 8015B Modified	Grab	SP	SP, then Once	-
PFAS	ng/L	EPA 1633	Grab	SP ^[4]	-	-
Priority Pollutants, other than limited parameters ^[5]	µg/L	-	Grab	SP	SP, then Once	-
Municipal Supply Pollutants ^[6]	µg/L	-	Grab	-	Once	-

Footnotes:

- ^[1] See MRP (Attachment E) section 5.1 for startup phase monitoring requirements.
- ^[2] Total residual chlorine shall be monitored in effluent only when chlorine is present in the influent or used during treatment.
- ^[3] TPH shall be analyzed without silica-gel cleanup.
- ^[4] PFAS analytes shall include those listed in U.S. EPA method 1633. For Dischargers enrolled as of the effective date of this Order, monitoring shall occur at least one time by the end of 2027.
- ^[5] The Discharger shall monitor all priority pollutants listed in Attachment G. Monitoring may be conducted concurrently with other priority pollutants listed on MRP Table E-2 with more frequent monitoring. Mercury shall be analyzed using ultra-clean techniques as described in U.S. EPA methods 1669 and 1631 to eliminate potential sample contamination. Monitoring of bis(2-ethylhexyl)phthalate shall also be performed using ultra clean sampling techniques.
- ^[6] The Discharger shall monitor for the pollutants with Primary Maximum Contaminant Levels (MCLs), except for radionuclides. This monitoring requirement applies only to Dischargers discharging to "Receiving Waters Used as Drinking Water," defined as surface waters with existing or potential beneficial uses of "Municipal and Domestic Supply" or "Groundwater Recharge," or both. The MCLs can be found in Title 22 Table 64431-A (Inorganic Chemicals) of section 64431, Table 64433.2-A (Fluoride) of section 64433.2, and Table 64444-A (Organic Chemicals) of section 64444 of the California Code of Regulations. Priority pollutant monitoring conducted in accordance with the table above may be used to satisfy the monitoring requirement for municipal supply pollutants that are also priority pollutants.

3.2. Class 4: Dischargers shall monitor influent, effluent, and receiving water at monitoring locations established in accordance with Table E-1 as follows:

TABLE E-3. Minimum Monitoring for Class 4

Parameter	Unit	Suggested Analytical Test Method	Sample Type	Influent	Effluent Water	Receiving Water
Flow	gpm	-	Continuous	-	Continuous	-
pH	standard units	EPA 150.2	Grab	-	Startup Phase (SP) ^[1] , then 1/Month	-

Parameter	Unit	Suggested Analytical Test Method	Sample Type	Influent	Effluent Water	Receiving Water
Chlorine, Total Residual ^[2]	mg/L	Field Kit, EPA 330 or SM4500-Cl	Grab	SP	SP, then 1/Month	-
Turbidity	NTU	EPA 180.1 or SM 2130B	Grab	-	SP, then 1/Month	SP
Total Dissolved Solids	mg/L	-	Grab		SP, then 1/Quarter	SP
Salinity	‰	-	Grab		SP, then 1/Quarter	SP
Antimony, Total Recoverable	µg/L	EPA 204.2 or EPA 200.8	Grab	SP	SP, then 1/Quarter	-
Arsenic, Total Recoverable	µg/L	EPA 206.3 or EPA 200.8	Grab	SP	SP, then 1/Quarter	-
Cadmium, Total Recoverable	µg/L	EPA 200.9 or EPA 200.8	Grab	SP	SP, then 1/Quarter	-
Chromium VI	µg/L	EPA 218.6 or EPA 7199	Grab	SP	SP, then 1/Quarter	-
Copper, Total Recoverable	µg/L	EPA 200.9 or EPA 200.8	Grab	SP	SP, then 1/Quarter	-
Lead, Total Recoverable	µg/L	EPA 200.9 or EPA 200.8	Grab	SP	SP, then 1/Quarter	-
Mercury, Total Recoverable ^[3]	µg/L	EPA 1631	Grab	SP	SP, then 1/Quarter	-
Nickel, Total Recoverable	µg/L	EPA 200.9 or EPA 200.8	Grab	SP	SP, then 1/Quarter	-
Selenium, Total Recoverable	µg/L	EPA 200.9 or EPA 200.8	Grab	SP	SP, then Once	-
Silver, Total Recoverable	µg/L	EPA 200.9 or EPA 200.8	Grab	SP	SP, then 1/Quarter	-
Thallium, Total Recoverable	µg/L	EPA 200.9 or EPA 200.8	Grab	SP	SP, then 1/Quarter	-
Zinc, Total Recoverable	µg/L	EPA 200.8	Grab	SP	SP, then 1/Quarter	-
Cyanide, Total ^[4]	µg/L	SM 4500-CN D or E	Grab	SP	SP, then 1/Quarter	-

Parameter	Unit	Suggested Analytical Test Method	Sample Type	Influent	Effluent Water	Receiving Water
Dichlorobromomethane ^[4]	µg/L	EPA 624.1 or EPA 8260B	Grab	SP	SP, then 1/Month	-
Benzene ^[4]	µg/L	EPA 624.1 or EPA 8260B	Grab	SP	SP, then 1/Month	-
Chloroform ^[4]	µg/L	EPA 624.1 or EPA 8260B	Grab	SP	SP, then 1/Month	-
1,1-Dichloroethane ^[4]	µg/L	EPA 624.1 or EPA 8260B	Grab	SP	SP, then 1/Month	-
1,2-Dichloroethane ^[4]	µg/L	EPA 624.1 or EPA 8260B	Grab	SP	SP, then 1/Month	-
1,1-Dichloroethylene ^[4]	µg/L	EPA 624.1 or EPA 8260B	Grab	SP	SP, then 1/Month	-
Ethylbenzene ^[4]	µg/L	EPA 624.1 or EPA 8260B	Grab	SP	SP, then 1/Month	-
Methylene Chloride ^[4]	µg/L	EPA 624.1 or EPA 8260B	Grab	SP	SP, then 1/Month	-
Tetrachloroethylene ^[4]	µg/L	EPA 624.1 or EPA 8260B	Grab	SP	SP, then 1/Month	-
Toluene ^[4]	µg/L	EPA 624.1 or EPA 8260B	Grab	SP	SP, then 1/Month	-
Cis-1,2-Dichloroethylene ^[4]	µg/L	EPA 624.1 or EPA 8260B	Grab	SP	SP, then 1/Month	-
Trans-1,2-Dichloroethylene ^[4]	µg/L	EPA 624.1 or EPA 8260B	Grab	SP	SP, then 1/Month	-
1,1,1-Trichloroethane ^[4]	µg/L	EPA 624.1 or EPA 8260B	Grab	SP	SP, then 1/Month	-
1,1,2-Trichloroethane ^[4]	µg/L	EPA 624.1 or EPA 8260B	Grab	SP	SP, then 1/Month	-
Trichloroethylene ^[4]	µg/L	EPA 624.1 or EPA 8260B	Grab	SP	SP, then 1/Month	-
Vinyl Chloride ^[4]	µg/L	EPA 624.1 or EPA 8260B	Grab	SP	SP, then 1/Month	-

Parameter	Unit	Suggested Analytical Test Method	Sample Type	Influent	Effluent Water	Receiving Water
2,4-Dichlorophenol ^{[4],[5]}	µg/L	EPA 625.1 or EPA 8270D	Grab	SP	SP, then 1/Month	-
2,4,6-Trichlorophenol ^{[4],[5]}	µg/L	EPA 625.1 or EPA 8270D	Grab	SP	SP, then 1/Month	-
Benzidine ^{[4],[5]}	µg/L	EPA 625.1 or EPA 8270D	Grab	SP	SP, then 1/Month	-
Bis(2-Chloroethyl)Ether ^{[4],[5]}	µg/L	EPA 625.1 or EPA 8270D	Grab	SP	SP, then 1/Month	-
Chrysene ^{[4],[5]}	µg/L	EPA 625.1 or EPA 8270D	Grab	SP	SP, then 1/Month	-
3,3'-Dichlorobenzidine ^{[4],[5]}	µg/L	EPA 625.1 or EPA 8270D	Grab	SP	SP, then 1/Month	-
2,4-Dinitrotoluene ^{[4],[5]}	µg/L	EPA 625.1 or EPA 8270D	Grab	SP	SP, then 1/Month	-
1,2-Diphenylhydrazine ^{[4],[5]}	µg/L	EPA 625.1 or EPA 8270D	Grab	SP	SP, then 1/Month	-
Hexachlorobenzene ^{[4],[5]}	µg/L	EPA 625.1 or EPA 8270D	Grab	SP	SP, then 1/Month	-
1,2,4-Trichlorobenzene ^{[4],[5]}	µg/L	EPA 625.1 or EPA 8270D	Grab	SP	SP, then 1/Month	-
Xylenes ^[4]	µg/L	EPA 624.1 or EPA 8260B	Grab	SP	SP, then 1/Month	-
Methyl Tertiary-Butyl Ether ^[4]	µg/L	EPA 624.1 or EPA 8260B	Grab	SP	SP, then 1/Month	-
TPH as Gasoline ^{[4],[6]}	µg/L	EPA 8260B Modified or EPA 8015B Modified	Grab	SP	SP, then 1/Month	-
TPH as Diesel ^{[4],[6]}	µg/L	EPA 8015B Modified	Grab	SP	SP, then 1/Month	-
TPH as Motor Oil ^{[4],[6]}	µg/L	EPA 8015B Modified	Grab	SP	SP, then 1/Month	-
PFAS	ng/L	EPA 1633	Grab	SP ^[7]	-	-
Priority Pollutants, other than limited parameters ^[8]	µg/L	-	Grab	SP	SP, then Once	-

Parameter	Unit	Suggested Analytical Test Method	Sample Type	Influent	Effluent Water	Receiving Water
Municipal Supply Pollutants ^[9]	µg/L	-	Grab	-	Once	-

Footnotes:

- ^[1] See MRP section 5.1 for startup phase monitoring requirements.
- ^[2] Total residual chlorine shall be monitored in effluent only when chlorine is present in the influent or used during treatment.
- ^[3] Mercury shall be analyzed using ultra-clean techniques as described in U.S. EPA methods 1669 and 1631 to eliminate potential sample contamination.
- ^[4] Influent and effluent monitoring are required only if the pollutant is known to be present in the influent at concentrations greater than test method detection limit. Dischargers enrolled as of the effective date of this Order may use historical monitoring data to evaluate the applicability of this monitoring requirement. Otherwise, three monthly influent monitoring results shall be submitted with the Discharger's first self-monitoring report due February 15, 2027. Dischargers enrolled after the effective date of this Order shall use monitoring data collected during the application process and startup phase to determine the applicability of this monitoring requirement.
- ^[5] Monitoring shall be performed using low-level detection techniques to achieve reporting levels below effluent limitations.
- ^[6] TPH shall be analyzed without silica-gel cleanup.
- ^[7] PFAS analytes shall include those listed in U.S. EPA method 1633. If PFAS in Table 2 of the Order are detected in influent at concentrations greater than test method reporting limits and exceed their effluent limits, then the Discharger shall monitor in accordance with MRP section 3.4. For Dischargers enrolled as of the effective date of this Order, monitoring shall occur at least one time by the end of 2027; if PFAS in Table 2 are detected in influent at concentrations greater than test method reporting limits and exceed their effluent limits, then beginning in 2028, the Discharger shall monitor in accordance with MRP section 3.4.
- ^[8] The Discharger shall monitor all priority pollutants listed in Attachment G. Monitoring may be conducted concurrently with other priority pollutants listed on MRP Table E-3 with more frequent monitoring. Mercury shall be analyzed using ultra-clean techniques as described in U.S. EPA methods 1669 and 1631 to eliminate potential sample contamination. Monitoring of bis(2-ethylhexyl)phthalate shall also be performed using ultra clean sampling techniques.
- ^[9] The Discharger shall monitor for the pollutants with Primary Maximum Contaminant Levels (MCLs), except for radionuclides. This monitoring requirement applies only to Dischargers discharging to "Receiving Waters Used as Drinking Water," defined as surface waters with existing or potential beneficial uses of "Municipal and Domestic Supply" or "Groundwater Recharge," or both. The MCLs can be found in Title 22 Table 64431-A (Inorganic Chemicals) of section 64431, Table 64433.2-A (Fluoride) of section 64433.2, and Table 64444-A (Organic Chemicals) of section 64444 of the California Code of Regulations. Priority pollutant monitoring conducted in accordance with the table above may be used to satisfy the monitoring requirement for municipal supply pollutants that are also priority pollutants.

3.3. Effluent Monitoring Requirements:

- 3.3.1. Effluent sampling shall occur concurrently (within 30 minutes) with influent sampling unless the Executive Officer stipulates otherwise.
- 3.3.2. Grab samples shall be collected on random days during periods of daytime maximum flow (if flow varies significantly during the day).
- 3.3.3. When any type of bypass occurs, grab samples shall be collected daily at all affected discharge points for the duration of the bypass for all constituents are detected in the influent that have effluent limits.
- 3.3.4. If monitoring results indicate a violation of any effluent limit other than a selenium effluent limit, the Discharger shall take an effluent confirmation sample within 24 hours of becoming aware of the violation. The Discharger shall have the confirmation sample analyzed by expedited methods and obtain results within 24 hours of sample collection. The Discharger shall request the shortest turnaround time possible if results cannot be obtained within 24 hours. If the confirmation sampling results also violate the effluent limit, the Discharger shall cease discharge until it corrects the cause of the violation. In this case, both the initial and confirmation sampling results are violations. However, if the

confirmation sample indicates compliance, only the initial exceedance is a violation, and the Discharger may continue to discharge.

- 3.4. PFAS Monitoring Requirements:** If PFAS are detected during the application process described in section 6.3.2.1 of this Order or in the influent (see Tables E-2 and E-3), the Discharger shall monitor influent, midstream wastewater, and effluent at monitoring locations established in accordance with Table E-1 as follows:

TABLE E-4. Minimum Monitoring for PFAS

Parameter	Units	Analytical Test Method	Sample Type	Influent ^[3]	Midstream ^{[1],[3]}	Effluent ^[3]
PFAS	ng/L	EPA 1633 ^[2]	Grab	1/Quarter	1/Quarter	1/Quarter
TOC	mg/L	-	Grab	1/Quarter	1/Quarter	1/Quarter

Footnotes:

- ^[1] The Discharger shall conduct midstream monitoring if its treatment system includes more than one stage of adsorptive media treatment (e.g., GAC or ion exchange media vessels in series).
- ^[2] PFAS analytes shall include those listed in U.S. EPA method 1633.
- ^[3] Pursuant to Attachment E section 6.5, if the Discharger concludes it cannot meet this Order's PFAS requirements (e.g., due to high groundwater salinity), the Discharger shall monitor only once, but only with prior approval from the Executive Officer. No midstream monitoring is required.

- 3.4.1. The Discharger shall monitor influent, midstream wastewater, and effluent for total organic carbon (TOC) and PFAS concurrently (within 30 minutes).
- 3.4.2. For a treatment system with more than one stage of adsorptive media treating PFAS, the Discharger shall adopt midstream monitoring strategies to detect adsorptive media breakthrough and implement corrective actions, such as media replacement, to comply with this Order's PFAS effluent limitations. The Discharger shall submit a PFAS Treatment Evaluation Report as described in Attachment E section 6.5 if it determines, after implementing corrective actions, that it cannot meet this Order's PFAS effluent limitations.

4. RECEIVING WATER MONITORING REQUIREMENTS

- 4.1. The Discharger shall monitor Monitoring Location RSW-00n as specified in Tables E-2 and E-3.
- 4.2. For tidally-influenced receiving waters, samples shall be collected within 1 hour following low slack water. Where sampling at lower slack water is impractical, sampling shall be performed during higher slack water.
- 4.3. Samples shall be collected within one foot of the surface of the receiving water. The Discharger shall explain any deviation from this requirement in each monitoring report if this requirement cannot be met.
- 4.4. Receiving water monitoring is not required when there is no water in the receiving water other than the discharge.

5. OTHER MONITORING REQUIREMENTS

5.1. Startup Phase Monitoring. The Discharger must perform Startup Phase monitoring when it commences discharge for the first time. The Discharger must also repeat Startup Phase monitoring before it resumes discharge if both (1) its treatment system is shut down more than seven days for reasons unrelated to scheduled maintenance and (2) when it violated effluent limits in the previous two calendar years. During Startup Phase monitoring, influent and effluent monitoring shall occur on the first day of operation and fifth day of discharge, as set forth in Tables E-2 and E-3. Startup Phase monitoring consists of the following steps:

- 5.1.1. On the first day of operation, the Discharger shall monitor the influent and effluent after starting up the treatment system following its standard operating procedures. No discharge to the receiving water shall occur until effluent monitoring indicates compliance with this Order's requirements. Influent and effluent monitoring must be repeated if the treatment system is shut down for more than 14 calendar days after monitoring.
- 5.1.2. The Discharger may commence discharge to the receiving water for five calendar days (120 hours) upon receiving monitoring results compliant with this Order's requirements, as described in Attachment E section 5.1.1. On the fifth day of discharge to the receiving water (weekend days may be excluded), the Discharger shall monitor the influent and effluent. Discharge may continue for up to an additional 14 calendar days or until the results are received, whichever is sooner. If the results are not received within 14 calendar days or they show non-compliance with the Order's requirements, the Discharger must cease discharge and repeat Startup Phase monitoring until compliance is achieved. Any non-compliant effluent shall not be discharged and shall be retreated or disposed of in accordance with applicable regulations.

5.2. Standard Observations

- 5.2.1. **Groundwater Treatment System.** The Discharger shall conduct the following standard observations monthly at its groundwater treatment system when it is discharging and during effluent confirmation sampling:
 - 5.2.1.1. Odor: presence or absence, characterization, source, distance of travel, and wind direction.
 - 5.2.1.2. Weather conditions: air temperature and total precipitation during the five days prior to observation.
 - 5.2.1.3. Floating material (e.g., algae), deposits, discolorations, or plugging in the conveyance system that could adversely affect the treatment system reliability performance.

- 5.2.1.4. Operation of level alarms, float or level switches, auto-dialers, chemical dosing systems, valves, outlets, and/or pressure shutoff valves in conveyance system.
- 5.2.1.5. Integrity of spill containment solutions (e.g., berms), piping, hoses, and manifolds.
- 5.2.2. **Receiving Water.** The Discharger shall conduct the following standard observations during effluent confirmation sampling if it discharges directly to receiving waters (i.e., not via storm drains):
 - 5.2.2.1. Floating and suspended materials (e.g., oil, grease, algae, and other macroscopic particulate matter): presence or absence, source, and size of affected area.
 - 5.2.2.2. Discoloration and turbidity: color, source, and size of affected area.
 - 5.2.2.3. Odor: presence or absence, characterization, source, and distance of travel.
 - 5.2.2.4. Beneficial water use: estimated number of water-associated waterfowl or wildlife, fisherpeople, and other recreational activities.
 - 5.2.2.5. Hydrographic condition: time and height of high and low tides (corrected to nearest National Oceanic and Atmospheric Administration location for the monitoring date and time).
 - 5.2.2.6. Weather conditions: wind direction, air temperature, and total precipitation during five days prior to observation.

6. REPORTING REQUIREMENTS

6.1. General Reporting Requirements

The Discharger shall comply with all Standard Provisions (Attachments D) related to monitoring, reporting, and recordkeeping.

6.2. Self-Monitoring Reports (SMRs)

- 6.2.1. **Format.** The Discharger shall submit self-monitoring reports (SMRs) via email to RB2-NPDES.GW@waterboards.ca.gov and as further instructed in its Authorization to Discharge. At any time during the term of this Order, the State or Regional Water Board may notify the Discharger to electronically submit SMRs using the State Water Board's California Integrated Water Quality System (CIWQS) website (<http://www.waterboards.ca.gov/ciwqs/index.html>). The CIWQS website will provide additional information for SMR submittal in the event of a planned service interruption.

6.2.2. **Due Dates and Contents.** The Discharger shall submit semi-annual SMRs and annual reports by the due dates and with the contents specified below.

Dischargers rescinding permit coverage before the end of the corresponding reporting period must still submit a semi-annual SMR and annual report for the remaining partial reporting period. Dischargers that have not discharged for an entire reporting period must still submit semi-annual SMRs to report the status of the discharge.

6.2.2.1. **Semi-Annual SMRs** — Semi-annual SMRs shall be due on August 15 or February 15 after each calendar semi-annual period (January 1 – June 30 and July 1 – December 31). Each SMR shall contain the items listed below:

6.2.2.1.1. Cover letter that includes the following information:

6.2.2.1.1.1. CIWQS ID of the permitted facility.

6.2.2.1.1.2. Operating status of the treatment facility during the reporting period.

6.2.2.1.1.3. Clear identification of any violations or a clear statement that there were no violations.

6.2.2.1.1.4. Detailed description of any violations, their causes, and corrective actions taken or proposed time schedule for corrective actions planned to resolve the violations and prevent recurrence. If previous reports address the corrective actions, then reference the earlier reports.

6.2.2.1.1.5. Explanation for any data invalidation. Data should not be submitted in a self-monitoring report if it does not meet quality assurance/quality control standards. However, if the Discharger wishes to invalidate a measurement after submitting it in a self-monitoring report, the Discharger shall identify the measurement suspected to be invalid and state the Discharger's intent to submit, within 60 days, a formal request to invalidate the measurement. The formal request shall include the original measurement in question, the reason for invalidating the measurement, all relevant documentation that supports invalidation (e.g., laboratory sheet, log entry, test results), and a discussion of the corrective actions taken or planned (with a time schedule for completion) to prevent recurrence of the sampling or measurement problem.

6.2.2.1.1.6. Signature and certification in accordance with Attachment D sections 5.2 and 5.3.

6.2.2.1.2. Introduction with project background information. A summary of treatment system status during the reporting period (e.g., in operation or on standby) that also addresses any non-routine treatment system shutdowns.

- 6.2.2.1.3. A statement of maximum discharge flowrate (gpm) during the reporting period.
- 6.2.2.1.4. A tabulated summary of monitored parameters and corresponding monitoring frequencies. The tabulated summary shall include parameters removed from the monitoring program with the corresponding last date of monitoring, if any.
- 6.2.2.1.5. A tabulated summary of all applicable standard observations required in the MRP.
- 6.2.2.1.6. For a Discharger treating PFAS, a tabulated summary of adsorptive media replacements, if any, including bed size (in pounds), bed life (in days), and bed volumes per spent media vessel since the initial date of discharge.
- 6.2.2.1.7. A detailed discussion of maintenance and operation activities or (e.g., media changeouts) or improvements performed on the treatment system. For a Discharger treating PFAS, the discussion should include a description of the criteria used to replace adsorption media, if any.
- 6.2.2.1.8. An electronic spreadsheet (e.g., Microsoft Excel) containing all new monitoring results obtained since submitting the last SMR. The results shall include information such as monitoring location name (e.g., INF-00n, MID-00n, EFF-00n, RSW-00n), parameter, result type (e.g., analytical result or calculated result) analytical method, calculation type (e.g., daily maximum or average monthly), test result, unit, method detection limit, reporting limit, sampling date, analytical date, and related qualification parameters as provided by the laboratory director or other responsible laboratory official. Laboratory reports shall be included in an appendix.
- 6.2.2.1.9. For any pollutant monitored more frequently than required by this Order, the Discharger shall include the results of such monitoring in the calculations and reporting for the SMR. If the analytical data for samples collected during a semi-annual period are unavailable for incorporation into that semi-annual SMR, then the status of laboratory reports shall be reported, and the data shall be included in the next semi-annual SMR.
- 6.2.2.2. **Annual Reports** — Annual Reports shall be due February 15 each year, covering the previous calendar year and may be included in semi-annual SMRs. Annual Reports shall cover the period of January 1 through December 31 and contain the items described below:
- 6.2.2.2.1. Annual compliance summary.
- 6.2.2.2.2. Comprehensive discussion of performance and compliance. This summary shall include any corrective actions taken or planned, such as changes to equipment or operations that may be needed to achieve

compliance and any other actions taken or planned that are intended to improve the performance and reliability of the Discharger's practices.

6.2.2.2.3. Contingency Plan review as required by Provision 6.3.3 of this Order.

6.2.3. **Monitoring Periods.** Monitoring periods for all required monitoring shall be as set forth in the table below:

Table E-5. Monitoring Periods

Sampling Frequency	Monitoring Period Begins On	Monitoring Period
Continuous	First day of discharge	All times while the facility is discharging
SP	First day of Startup Phase Monitoring	First day of treatment system operation through fifth day of discharge to the receiving water.
1/Month	First day of calendar month following the last day of startup phase	First day of calendar month through last day of calendar month
1/Quarter	Closest of January 1, April 1, July 1, or October 1 before or after last day of startup phase ^[1]	January 1 through March 31 April 1 through June 30 July 1 through September 30 October 1 through December 31
1/Year	Closest January 1 before or after last day of startup phase ^[1]	January 1 through December 31
Once	Effective date of this Order	Once during the term of the Order so that all related information is submitted no later than October 3, 2030.

Footnote:

^[1] Monitoring performed before the effective date of an Authorization to Discharge may be used to satisfy the monitoring required by this Order.

6.2.4. **RL and MDL Reporting.** The Discharger shall report with each sample result the Reporting Level (RL) and Method Detection Limit (MDL) as determined by the procedure in 40 C.F.R. part 136. The Discharger shall report the results of analytical determinations for the presence of chemical constituents in a sample using the following reporting protocols:

6.2.4.1. Sample results greater than or equal to the RL shall be reported as measured by the laboratory (i.e., the measured chemical concentration in the sample).

6.2.4.2. Sample results less than the RL, but greater than or equal to the laboratory's MDL, shall be reported as "Detected, but Not Quantified," or DNQ. The estimated chemical concentration of the sample shall also be reported. For purposes of data collection, the laboratory shall write the estimated chemical concentration next to DNQ. The laboratory may, if such information is available, include numerical estimates of the data quality for the reported result. Numerical estimates of data quality may be percent accuracy ($\pm a$

percentage of the reported value), numerical ranges (low to high), or any other means the laboratory considers appropriate.

- 6.2.4.3. Sample results less than the laboratory's MDL shall be reported as "Not Detected" or "ND."
- 6.2.4.4. The Discharger shall instruct laboratories to establish calibration standards so that the lowest calibration standard is at or below the minimum level specified below (or its equivalent if there is differential treatment of samples relative to calibration standards). At no time is the Discharger to use analytical data derived from extrapolation beyond the lowest point of the calibration curve. Attachment G lists minimum levels for priority pollutants.
- 6.2.5. **Compliance Determination.** Compliance with effluent limitations shall be determined using sample reporting protocols defined above, in the Fact Sheet, and in Attachments A and D. For purposes of reporting and administrative enforcement by the Regional Water Board and State Water Board, the Discharger shall be deemed out of compliance with effluent limitations if the concentration of the pollutant in the monitoring sample is greater than the effluent limitation and, if applicable, greater than or equal to the RL.
- 6.2.5.1. **Multiple Samples.** When determining compliance with effluent limitations (other than instantaneous effluent limitations) and more than one sample result is available, the Discharger shall compute the arithmetic mean. If the data set contains one or more results that are "Detected, but Not Quantified" (DNQ) or "Not Detected" (ND), the Discharger shall instead compute the median in accordance with the following procedure:
- 6.2.5.1.1. The data set shall be ranked from low to high, reported ND determinations lowest, DNQ determinations next, followed by quantified values (if any). The order of the individual ND or DNQ determinations is unimportant.
- 6.2.5.1.2. The median of the data set shall be determined. If the data set has an odd number of data points, the median is the middle value. If the data set has an even number of data points, the median is the average of the two values around the middle, unless one or both of these values is ND or DNQ, in which case the median shall be the lower of the two results (where DNQ is lower than a quantified value and ND is lower than DNQ).
- 6.2.5.2. **Duplicate Samples.** The Discharger shall report the average of duplicate sample analyses when reporting for a single sample result (or the median if one or more of the duplicates is DNQ or ND (see Provision 6.2.5.1, above).

6.3. Discharge Monitoring Reports (DMRs)

The Discharger shall submit Discharge Monitoring Reports (DMRs) in accordance with Attachment D section 5.3.2 if instructed to do so by the Regional Water Board or State Water Board.

6.4. PFAS Monitoring Summary Report

Any Discharger treating PFAS and either seeking to terminate permit coverage or filing a new NOI to continue discharging after this Order's expiration date shall submit a cover letter and electronic spreadsheet (e.g., using Microsoft Excel) containing all PFAS and TOC monitoring results obtained since the initial date of discharge. The Discharger shall include the report with the forms and monitoring data required in Attachment B or C of this Order, as applicable. The results shall include monitoring location name (e.g., Monitoring Location INF-00n, MID-00n, or EFF-00n), PFAS and TOC parameters, result type (e.g., analytical result or calculated result), analytical method, calculation type (e.g., daily maximum or average monthly), test result, unit, method detection limit, reporting limit, sampling date, analytical date, and related qualification parameters as provided by the laboratory director or other responsible laboratory official. The spreadsheet shall also identify dates when adsorption media replacement occurred and where.

6.5. PFAS Treatment Evaluation Report

- 6.5.1. If the Discharger cannot meet this Order's PFAS effluent limitations, it shall submit a PFAS Treatment Evaluation Report, no later than 90 calendar days after the last non-compliance event, that evaluates treatment performance and identifies alternative corrective actions. The report shall include the following:
- 6.5.1.1. Description of treatment facility and operational activities in the past year (e.g., treatment shutdowns, maintenance activities) leading up to the breakthrough in the adsorptive media.
 - 6.5.1.2. Description of adsorptive media and design features, including bed size (in pounds), bed life (in days), and bed volume of adsorptive media where breakthrough was observed.
 - 6.5.1.3. Tabulated history of adsorptive media replacements, including bed size (in pounds), bed life (in days), and bed volumes per spent media vessel since the initial date of discharge.
 - 6.5.1.4. Analysis of influent, midstream, and effluent TOC and PFAS monitoring data that shows treatment performance trends leading up to the detection of adsorptive media breakthrough. The analysis shall include a discussion of bed life and bed volumes, adsorption media receptor sites, non-PFAS and PFAS-competing compounds, and tabulated and graphical summaries of TOC and PFAS monitoring data.
 - 6.5.1.5. Discussion of proposed or adopted corrective actions that maintain high PFAS treatment performance and compliance with this Order's requirements, including any new criteria for adsorptive media management.

6.6. Permit Violations

- 6.6.1. Within 24 hours of becoming aware of a violation of this Order, the Discharger shall report by telephone and email to the Regional Water Board staff overseeing this Order (see Authorization to Discharge).
- 6.6.2. The Discharger shall report spills to the California Office of Emergency Services (telephone 800-852-7550) when spills meet or exceed applicable reportable quantities for hazardous materials listed in 40 C.F.R. part 302.
- 6.6.3. The Discharger shall submit a written report to the Regional Water Board via email to RB2-NPDES.GW@waterboards.ca.gov within five calendar days following the telephone or email notifications described in sections 6.4.1, 6.4.2, and 6.4.3 above unless directed otherwise by Regional Water Board staff in writing (weekend days may be excluded). Electronic submittal is acceptable. The written report shall include the following:
 - 6.6.3.1. Date, time and duration of violation or spill;
 - 6.6.3.2. Location of violation or spill (street address or description of location);
 - 6.6.3.3. Nature of violation or material spilled;
 - 6.6.3.4. Volume and quantity of any material involved;
 - 6.6.3.5. Receiving water affected, if any;
 - 6.6.3.6. Cause of violation or spill;
 - 6.6.3.7. Estimated size of affected area;
 - 6.6.3.8. Observed receiving water impacts (e.g., oil sheen, fish kill, or water discoloration);
 - 6.6.3.9. Actions taken to correct violation or to contain, minimize, or clean up spill;
 - 6.6.3.10. Future corrective actions planned to prevent recurrence and implementation schedule; and
 - 6.6.3.11. Persons or agencies notified.

ATTACHMENT F – FACT SHEET

CONTENTS

1. PERMIT INFORMATION F-3

2. FACILITY AND DISCHARGE DESCRIPTIONS..... F-3

 2.1. Facility Descriptions F-3

 2.2. Water Reclamation..... F-4

 2.3. Discharge Points and Receiving Waters F-4

 2.4. Previous Orders Requirements F-5

3. APPLICABLE PLANS, POLICIES, AND REGULATIONS F-8

 3.1. Legal Authorities F-8

 3.2. California Environmental Quality Act (CEQA) F-8

 3.3. State and Federal Laws, Regulations, Policies, and Plans F-8

 3.4. Impaired Water Bodies on CWA section 303(d) List F-12

4. RATIONALE FOR EFFLUENT LIMITATIONS AND DISCHARGE SPECIFICATIONS F-12

 4.1. Discharge Prohibitions F-13

 4.1.1. Prohibitions in this Order F-13

 4.1.2. Basin Plan Discharge Prohibition 1 F-13

 4.2. Technology-Based Effluent Limitations F-14

 4.2.1. Scope and Authority F-14

 4.2.2. Applicable Limitations..... F-15

 4.2.3. 40 C.F.R. Section 125.3(d) Factors..... F-19

 4.3. Water Quality-Based Effluent Limitations..... F-20

 4.3.1. Scope and Authority F-20

 4.3.2. Beneficial Uses and Water Quality Criteria and Objectives F-20

 4.3.3. Reasonable Potential Analysis..... F-24

 4.3.4. Water Quality-Based Effluent Limitations..... F-39

 4.4. Discharge Requirement Considerations F-42

5. RATIONALE FOR RECEIVING WATER LIMITATIONS..... F-45

6. RATIONALE FOR PROVISIONS F-46

 6.1. Standard Provisions F-46

 6.2. Monitoring and Reporting Provisions F-46

 6.3. Special Provisions..... F-46

 6.3.1. Reopener Provisions F-46

 6.3.2. Application for General Permit Coverage and Authorization to Discharge..... F-46

 6.3.3. Contingency Plan F-47

 6.3.4. Spill Prevention Plan F-47

 6.3.6. Water Reclamation..... F-47

 6.3.7. No Preemption F-47

7. RATIONALE FOR MONITORING AND REPORTING REQUIREMENTS F-50

8. PUBLIC PARTICIPATION F-51

TABLES

TABLE F-1. EFFLUENT LIMITATIONS FOR CLASS 1 AND 2 DISCHARGES F-5
TABLE F-2. EFFLUENT LIMITATIONS FOR CLASS 3 DISCHARGES F-5
TABLE F-3. EFFLUENT LIMITATIONS FOR CLASS 4 DISCHARGES F-6
TABLE F-4. TECHNOLOGY-BASED EFFLUENT LIMITATIONS F-16
TABLE F-5. 40 C.F.R. SECTION 125.3(D) FACTORS F-19
TABLE F-6. COPPER AND NICKEL TRANSLATORS F-23
TABLE F-7. REASONABLE POTENTIAL ANALYSIS – CLASSES 1, 2, AND 3 F-26
TABLE F-8. REASONABLE POTENTIAL ANALYSIS – CLASS 4 F-30
TABLE F-9. WQBELS SUMMARY – CLASS 1-3 DISCHARGES F-40
TABLE F-10. WQBELS SUMMARY – CLASS 4 DISCHARGES F-40

ATTACHMENT F – FACT SHEET

This Fact Sheet includes the legal requirements and technical rationale that serve as the basis for the requirements of this Order. As described in section 2.2 of the Order, the Regional Water Board incorporates this Fact Sheet as findings supporting the issuance of the Order.

1. PERMIT INFORMATION

- 1.1. This Order regulates the discharge and reclamation of groundwater extracted and treated at construction sites or active and closed cleanup sites, such as former industrial sites and fuel stations. It also regulates discharges of extracted brackish groundwater, reverse osmosis (RO) concentrate from treated brackish groundwater, and extracted groundwater resulting from structural dewatering requiring minimal treatment. It reissues NPDES General Permit CAG912002, which the Regional Water Board adopted through Order R2-2017-0048 on December 13, 2017, and amended by Order R2-2018-0050 on November 14, 2018. This Order also incorporates and updates the requirements previously covered under NPDES General Permit CAG912004, which the Regional Water Board adopted through Order R2-2018-0026 on June 13, 2018. The previous orders became effective on January 1, 2019. Adoption of this Order rescinds NPDES General Permit CAG912004.
- 1.2. Any facility owner or operator that completes an NOI form and thereby applies for an Authorization to Discharge under this Order, and that is granted such authorization, is hereinafter called a “Dischargers.” For purposes of this Order, references to “discharger” or “permittee” in applicable federal and State laws, regulations, plans, and policies are held to be equivalent to references to a Discharger herein.

2. FACILITY AND DISCHARGE DESCRIPTIONS

2.1. Facility Descriptions

This Order covers treatment facilities that extract and treat groundwater polluted by the priority pollutants listed in Attachment G of this Order and other pollutants that may pose a threat to water quality. These facilities may be found at construction sites, active or closed cleanup sites, aquifer reclamation program areas, and other locations where long-term dewatering is needed to maintain structural integrity and minimal groundwater treatment is required. This Order addresses discharges from these facilities to any surface waters that are waters of the United States, including creeks, streams, rivers, (including flood control channels), lakes, and San Francisco Bay. Such discharges may occur directly to surface waters or through constructed storm drain systems.

- 2.1.1. **Class 1 (Aquifer reclamation program well discharges).** Class 1 facilities operate to protect drinking water supply aquifers or other municipal facilities from saltwater intrusion. For example, the Alameda County Water District,

operates a series of wells along the southeast side of San Francisco Bay. Historically, the District discharged extracted brackish groundwater from the Fremont-Newark area to flood control channels. No Class 1 facilities were enrolled during the previous order term.

- 2.1.2. **Class 2 (RO concentrate from aquifer reclamation program well discharges to estuarine or marine receiving waters).** Class 2 facilities treat brackish groundwater using RO to enhance drinking water supplies. The RO concentrate is discharged as wastewater. For example, the Alameda County Water District operates a desalination facility in Newark that treats brackish groundwater. Desalinated water is blended with other drinking water supplies and delivered to local customers. One Class 2 facility was enrolled during the previous order term.
- 2.1.3. **Class 3 (Groundwater discharged at flows of 10,000 gallons per day or greater requiring minimal or no treatment).** Class 3 facilities operate to dewater buildings, pipelines, and other facilities to control groundwater incursion or flooding (e.g., underground parking garages). Treatment may be required to remove pollutants (e.g., pH) that could pollute or contribute to pollution of receiving waters. Six Class 3 facilities were enrolled during the previous order term.
- 2.1.4. **Class 4 (All groundwater discharges requiring treatment).** Class 4 facilities operate to treat groundwater contaminated with priority pollutants, such as volatile organic compounds, fuel-related compounds, and metals, among others. These facilities typically use activated carbon and ion exchange technologies to remove these pollutants prior to discharge. Nearly 100 Class 4 facilities were enrolled during the previous order term.

2.2. Water Reclamation

Regional Water Board Resolution 88-160 (October 19, 1988) urges dischargers of extracted groundwater to reclaim it. The resolution states that when reclamation is not technically and economically feasible, treated effluent should be directed to a publicly owned treatment works. The Regional Water Board may authorize the discharge of treated groundwater in accordance with Waste Discharge Requirements (WDRs) only if neither reclamation nor discharge to a publicly owned treatment works is technically and economically feasible, and if receiving water beneficial uses are not adversely affected. This Order allows reclamation of treated groundwater in conjunction with discharge to surface waters. Reclamation can take many forms, such as dust control, landscape or agricultural irrigation, or industrial water supply.

2.3. Discharge Points and Receiving Waters

Dischargers may discharge directly or indirectly (e.g., via storm drains) to any receiving water in the San Francisco Bay Region, except the Pacific Ocean. For

purposes of this Order, these include Central, Lower, and South San Francisco Bay; San Pablo Bay; Carquinez Strait; Mare Island Strait; Suisun Bay; the Sacramento-San Joaquin Delta; and freshwater streams, creeks, and rives. The NOI form in Attachment B requires Dischargers to specify their discharge locations and illustrate the discharge path to receiving water, as applicable.

2.4. Previous Orders Requirements

The previous orders included the following effluent limitations:

Table F-1. Effluent Limitations for Class 1 and 2 Discharges

Parameter	Units	Receiving Waters Used as Drinking Water ^[1]		Other Receiving Waters	
		Average Monthly	Maximum Daily	Average Monthly	Maximum Daily
pH ^[2]	standard units	-	-	-	-
Turbidity ^[3]	NTU	5.0	10.	-	-
Chloride ^[3]	mg/L	250	500	-	-
Total Dissolved Solids (TDS) ^[3]	mg/L	500	1,010	-	-
Chlorine, Total Residual ^[4]	mg/L	-	-	-	-

Footnotes:

^[1] "Receiving Waters Used as Drinking Water" are surface waters with existing or potential beneficial uses of "Municipal and Domestic Supply" or "Groundwater Recharge," or both. Groundwater recharge beneficial uses may include recharge areas to maintain salt balance or to halt saltwater intrusion to freshwater aquifers.

^[2] pH was not to be lower than 6.5 or exceed 8.5 standard units at any time.

^[3] Applicable to Class 2 discharges only.

^[4] Total residual chlorine was not to exceed 0.0 mg/L at any time.

Table F-2. Effluent Limitations for Class 3 Discharges

Parameter	Units	Receiving Waters Used as Drinking Water ^[1]		Other Receiving Waters	
		Average Monthly	Maximum Daily	Average Monthly	Maximum Daily
pH ^[2]	standard units	-	-	-	-
Copper, Total Recoverable ^[3]					
<i>Lower or South SF Bay Discharge ^[4]</i>	µg/L	10.	20.	10.	20.
<i>Central SF Bay Discharge ^[4]</i>	µg/L	5.4	11	5.4	11
<i>Suisun or San Pablo Bay Discharge ^[4]</i>	µg/L	7.1	14	7.1	14
<i>Freshwater Discharge</i>	µg/L	7.0	14	7.0	14
Nickel, Total Recoverable ^[3]					
<i>Lower or South SF Bay Discharge ^[4]</i>	µg/L	22	44	22	44
<i>Central SF Bay Discharge ^[4]</i>	µg/L	10.	21	10.	21

Parameter	Units	Receiving Waters Used as Drinking Water ^[1]		Other Receiving Waters	
		Average Monthly	Maximum Daily	Average Monthly	Maximum Daily
<i>Suisun or San Pablo Bay Discharge</i> ^[4]	µg/L	25	50.	25	50.
<i>Freshwater Discharge</i>	µg/L	43	86	43	86
Selenium, Total Recoverable ^[5]	µg/L	4.1	8.2	4.1	8.2
Selenium, Total Recoverable ^[6]	µg/L	21	27	21	27
Chlorine, Total Residual ^[7]	mg/L	-	-	-	-

Footnotes:

- ^[1] "Receiving Waters Used as Drinking Water" are surface waters with existing or potential beneficial uses of "Municipal and Domestic Supply" or "Groundwater Recharge," or both. Groundwater recharge beneficial uses may include recharge areas to maintain salt balance or to halt saltwater intrusion to freshwater aquifers.
- ^[2] pH was not to be lower than 6.5 or exceed 8.5 standard units at any time.
- ^[3] The applicable limit depended on the sub-embayment into which the discharge eventually flowed. Freshwater limits applied when the receiving water salinity was no greater than one part per thousand at least 95 percent of the time.
- ^[4] These limits also applied to discharges to tidally influenced reaches of waters draining to San Francisco, San Pablo, and Suisun Bays.
- ^[5] These limits did not apply to Santa Clara University's discharge from 2505 The Alameda, Santa Clara.
- ^[6] These limits applied only to Santa Clara University's discharge from 2505 The Alameda, Santa Clara.
- ^[7] Total residual chlorine was not to exceed 0.0 mg/L at any time.

Table F-3. Effluent Limitations for Class 4 Discharges

Parameter	Units	Receiving Waters Used as Drinking Water ^[1]		Other Receiving Waters	
		Average Monthly	Maximum Daily	Average Monthly	Maximum Daily
pH ^[2]	standard units	-	-	-	-
Antimony, Total Recoverable	µg/L	-	6.0	4,300	8,600
Arsenic, Total Recoverable	µg/L	-	10.	30.	59
Cadmium, Total Recoverable	µg/L	0.90	1.8	0.90	1.8
Chromium III	µg/L	-	50.	170	340
Chromium VI	µg/L	-	10.	8.1	16
Copper, Total Recoverable ^[3]					
<i>Lower or South SF Bay Discharge</i> ^[4]	µg/L	10.	20.	10.	20.
<i>Central SF Bay Discharge</i> ^[4]	µg/L	5.4	11	5.4	11
<i>Suisun or San Pablo Bay Discharge</i> ^[4]	µg/L	7.1	14	7.1	14
<i>Freshwater Discharge</i>	µg/L	7.0	14	7.0	14
Lead, Total Recoverable	µg/L	2.6	5.2	2.6	5.2
Mercury, Total Recoverable	µg/L	0.050	0.10	0.050	0.10
Nickel, Total Recoverable ^[3]					
<i>Lower or South SF Bay Discharge</i> ^[4]	µg/L	22	44	22	44
<i>Central SF Bay Discharge</i> ^[4]	µg/L	10.	21	10.	21

Parameter	Units	Receiving Waters Used as Drinking Water ^[1]		Other Receiving Waters	
		Average Monthly	Maximum Daily	Average Monthly	Maximum Daily
<i>Suisun or San Pablo Bay Discharge</i> ^[4]	µg/L	25	50.	25	50.
<i>Freshwater Discharge</i>	µg/L	43	86	43	86
Selenium, Total Recoverable	µg/L	4.1	8.2	4.1	8.2
Silver, Total Recoverable	µg/L	1.1	2.2	1.1	2.2
Thallium, Total Recoverable	µg/L	-	2.0	6.3	13
Zinc, Total Recoverable	µg/L	47	95	47	95
Benzene	µg/L	-	0.50	-	0.50
Chloroform	µg/L	-	1.9	-	1.9
1,1-Dichloroethane	µg/L	-	0.50	-	0.50
1,2-Dichloroethane	µg/L	0.38	0.50	-	0.50
1,1-Dichloroethylene	µg/L	0.057	0.11	-	0.50
Ethylbenzene	µg/L	-	0.50	-	0.50
Tetrachloroethylene	µg/L	-	0.50	-	0.50
Toluene	µg/L	-	0.50	-	0.50
Cis-1,2-Dichloroethylene	µg/L	-	0.50	-	0.50
Trans-1,2-Dichloroethylene	µg/L	-	0.50	-	0.50
1,1,1-Trichloroethane	µg/L	-	0.50	-	0.50
1,1,2-Trichloroethane	µg/L	-	0.50	-	0.50
Trichloroethylene	µg/L	-	0.65	-	0.65
Vinyl Chloride	µg/L	-	0.50	-	0.90
Benzo(a)Anthracene	µg/L	0.0044	0.0088	0.049	0.098
Benzo(a)Pyrene	µg/L	0.0044	0.0088	0.049	0.098
Benzo(b)Fluoranthene	µg/L	0.0044	0.0088	0.049	0.098
Benzo(k)Fluoranthene	µg/L	0.0044	0.0088	0.049	0.098
Chrysene	µg/L	0.0044	0.0088	0.049	0.098
Dibenzo(a,h)Anthracene	µg/L	0.0044	0.0088	0.049	0.098
Indeno(1,2,3-cd)Pyrene	µg/L	0.0044	0.0088	0.049	0.098
Total Xylenes	µg/L	-	0.50	-	0.50
Methyl Tertiary Butyl Ether	µg/L	-	0.50	-	0.50
TPH as gasoline	µg/L	-	50	-	50
TPH as diesel	µg/L	-	50	-	50
TPH as motor oil	µg/L	-	100	-	100
Turbidity	NTU	5.0	10	-	-
Chlorine, Total Residual ^[5]	mg/L	-	-	-	-

Footnotes:

- ^[1] "Receiving Waters Used as Drinking Water" are surface waters with existing or potential beneficial uses of "Municipal and Domestic Supply" or "Groundwater Recharge," or both. Groundwater recharge beneficial uses may include recharge areas to maintain salt balance or to halt saltwater intrusion to freshwater aquifers.
- ^[2] pH was not to be lower than 6.5 or exceed 8.5 standard units at any time.
- ^[3] The applicable limit depended on the sub-embayment into which the discharge eventually flowed. Freshwater limits applied when the receiving water salinity was no greater than one part per thousand at least 95 percent of the time.
- ^[4] These limits also applied to discharges to tidally influenced reaches of waters draining to San Francisco, San Pablo, and Suisun Bays.

^[5] Total residual chlorine was not to exceed 0.0 mg/L at any time.

3. APPLICABLE PLANS, POLICIES, AND REGULATIONS

The requirements contained in this Order are based on the requirements and authorities described in this section.

3.1. Legal Authorities

This Order serves as WDRs pursuant to California Water Code article 4, section 4, division 7 (commencing with § 13260). This Order is also issued pursuant to federal Clean Water Act (CWA) section 402 and implementing regulations adopted by the U.S. EPA, and Water Code section 5.5, division 7 (commencing with § 13370). It serves as an NPDES permit for point source discharges to surface waters from enrolled facilities.

3.2. California Environmental Quality Act (CEQA)

Under Water Code section 13389, this action to adopt an NPDES permit is exempt from the provisions of the California Environmental Quality Act (CEQA), Public Resources Code division 13, section 3 (commencing with § 21100). This Order includes Discharge Prohibition 3.4 and the receiving water limitations in section 5 of the Order under State law only. These State law requirements are not subject to the exemption under Water Code section 13389. However, the previous order imposed requirements to address nuisance and toxicity that required similar compliance methods. As such, including these requirements is not a project subject to CEQA because doing so will not cause a direct or indirect physical change in the environment (Public Resources Code §§ 21065, 21080).

3.3. State and Federal Laws, Regulations, Policies, and Plans

- 3.3.1. **Water Quality Control Plan.** The Regional Water Board adopted the *Water Quality Control Plan for the San Francisco Bay Basin* (Basin Plan), which designates beneficial uses, establishes water quality objectives, and contains implementation programs and policies to achieve those objectives for all waters addressed through the plan. Requirements in this Order implement the Basin Plan. In addition, this Order implements State Water Board Resolution 88-63, which established State policy that all waters, with certain exceptions, should be considered suitable or potentially suitable for municipal or domestic supply. Receiving water beneficial uses include some or all of the following:

- Agricultural Supply
- Commercial and Sport Fishing
- Estuarine Habitat
- Fish Migration
- Fish Spawning
- Groundwater Recharge
- Industrial Process Supply
- Industrial Service Supply
- Municipal and Domestic Supply
- Navigation
- Preservation of Rare or Endangered Species
- Shellfish Harvesting
- Water Contact Recreation
- Non-Contact Water Recreation
- Wildlife Habitat

3.3.2. **National Toxics Rule (NTR) and California Toxics Rule (CTR).** The NTR and CTR contain federal water quality criteria for priority pollutants. U.S. EPA adopted the NTR on December 22, 1992, and amended it on May 4, 1995, and November 9, 1999. About 40 NTR criteria apply in California. U.S. EPA adopted the CTR on May 18, 2000. The CTR promulgated new toxics criteria for California and incorporated the NTR criteria that applied in the State. U.S. EPA amended the CTR on December 10, 2024, to promulgate a freshwater selenium criterion consisting of bird tissue, fish tissue, and water column elements.

3.3.3. **State Implementation Policy.** On March 2, 2000, the State Water Board adopted the *Policy for Implementation of Toxics Standards for Inland Surface Waters, Enclosed Bays, and Estuaries of California* (State Implementation Policy or SIP). The SIP establishes implementation provisions for priority pollutant criteria and objectives, and provisions for chronic toxicity control. The SIP became effective on April 28, 2000, with respect to the priority pollutant criteria U.S. EPA promulgated for California through the NTR and the priority pollutant objectives the Regional Water Board established through the Basin Plan. The SIP became effective on May 18, 2000, with respect to the priority pollutant criteria U.S. EPA promulgated through the CTR. The State Water Board adopted amendments to the SIP on February 24, 2005, that became effective on July 13, 2005. Requirements of this Order implement the SIP.

3.3.4. **Toxicity Provisions.** The State Water Board adopted the *State Policy for Water Quality Control: Toxicity Provisions* (Toxicity Provisions) on October 5, 2021. U.S. EPA approved the Toxicity Provisions on May 1, 2023. Toxicity Provisions sections II.C.1 and II.C.2 establish numeric chronic and acute toxicity objectives that apply to all inland surface waters, enclosed bays, and estuaries in the State with aquatic life beneficial uses. The Toxicity Provisions include related implementation provisions and require that compliance with the chronic toxicity water quality objectives be assessed using U.S. EPA's Test of Significant Toxicity (TST) (U.S. EPA, *National Pollutant Discharge Elimination System Test of Significant Toxicity Implementation Document [EPA/833-R-10-003]*, June 2010). This Order implements the Toxicity Provisions.

The Toxicity Provisions were challenged in *Camarillo Sanitary District v. State Water Resources Control Board* (2025) 113 Cal.App.5th 407 (Petn. for Review Pending, Petn. Filed Sept. 15, 2025). The Court of Appeal held that the use of the Test of Significant Toxicity to determine compliance with NPDES permits conflicts with federal law, but that the State Water Board had otherwise properly adopted the Toxicity Provisions as state policy for water quality control. This Order implements the Toxicity Provisions in a manner consistent with the Court of Appeal decision.

- 3.3.5. **Sediment Quality.** The State Water Board adopted the *Water Quality Control Plan for Enclosed Bays and Estuaries – Part 1, Sediment Quality* on September 16, 2008, and it became effective on August 25, 2009. The State Water Board adopted amendments to the plan on June 5, 2018, that became effective on March 11, 2019. This plan establishes sediment quality objectives and related implementation provisions for specifically defined sediments in most bays and estuaries.
- 3.3.6. **Safe Clean Water.** In compliance with Water Code section 106.3, it is State of California policy that every human being has the right to safe, clean, affordable, and accessible water adequate for human consumption, cooking, and sanitary purposes. This Order promotes that policy by requiring Dischargers to meet applicable water quality objectives, including maximum contaminant levels (MCLs) designed to protect human health, and to ensure that water is safe for domestic use. As explained in Fact Sheet section 4.3.3, the reasonable potential analysis for groundwater treatment facilities considered MCLs.
- 3.3.7. **Antidegradation Policy.** Federal regulations at 40 C.F.R. section 131.12 require that state water quality standards include an antidegradation policy consistent with the federal policy. The State Water Board established California's antidegradation policy through State Water Board Resolution 68-16, *Statement of Policy with Respect to Maintaining High Quality of Waters in California*, which incorporates the federal antidegradation policy where the federal policy applies under federal law. Resolution 68-16 requires that existing water quality be maintained unless degradation is justified based on specific findings. The Basin Plan implements, and incorporates by reference, both the State and federal antidegradation policies. Permitted discharges must be consistent with the antidegradation provisions of 40 C.F.R. section 131.12 and State Water Board Resolution 68-16.
- 3.3.8. **Anti-Backsliding Requirements.** CWA sections 402(o) and 303(d)(4) and 40 C.F.R. section 122.44(l) restrict backsliding in NPDES permits. These anti-backsliding provisions require that effluent limitations in a reissued permit be as stringent as those in the previous permit, with some exceptions in which limitations may be relaxed.
- 3.3.9. **Endangered Species Act Requirements.** This Order does not authorize any act that results in the taking of a threatened or endangered species or any act

that is now prohibited, or becomes prohibited in the future, under either the California Endangered Species Act (Fish and Game Code §§ 2050 to 2097) or Federal Endangered Species Act (16 U.S.C.A. §§ 1531 to 1544). This Order requires compliance with effluent limits, aquatic toxicity receiving water limitations, and other requirements to protect the beneficial uses of waters of the State, including protecting rare, threatened, or endangered species. Dischargers are responsible for meeting all applicable Endangered Species Act requirements.

3.4. Impaired Water Bodies on CWA section 303(d) List

On May 11, 2022, U.S. EPA approved a revised list of impaired waters pursuant to CWA section 303(d), which requires identification of specific water bodies where it is expected that water quality standards will not be met after implementation of technology-based effluent limitations on point sources. This list includes San Francisco Bay as a waterbody impaired by mercury, PCBs, selenium, chlordane, DDT, dieldrin, dioxin and furan compounds, and invasive species. This list also includes diazinon and pesticide-related toxicity in San Francisco Bay Area urban creeks. Where it has not done so already, the Regional Water Board plans to adopt total maximum daily loads (TMDLs) for pollutants on the 303(d) list. TMDLs establish wasteload allocations for point sources and load allocations for nonpoint sources and are established to achieve water quality standards.

The SIP requires effluent limitations for all 303(d)-listed pollutants to be consistent with TMDLs and associated wasteload allocations. A TMDL for mercury became effective February 12, 2008, and a TMDL for PCBs became effective March 29, 2010. Neither TMDL contains wasteload allocations for treated groundwater discharges because they are not known to be significant sources of mercury or PCBs. A TMDL for selenium in North San Francisco Bay became effective on August 23, 2016. This TMDL does not contain wasteload allocations for groundwater treatment facilities that discharge to surface waters because these facilities are not known to be significant sources of selenium in this sub-embayment. Groundwater treatment facilities that discharge to surface waters are also not known to be significant sources of chlordane, DDT, dieldrin, dioxin and furan compounds, or invasive species. A TMDL for diazinon and pesticide-related toxicity in San Francisco Bay Area urban creeks became effective May 21, 2007, which does not contain wasteload allocations for treated groundwater discharges because they are not known to be sources of diazinon or pesticide-related toxicity. Additionally, discharges regulated through this Order are not expected to contribute to any water quality impairment because this Order's effluent limitations are based on water quality objectives protective of receiving water beneficial uses.

4. RATIONALE FOR EFFLUENT LIMITATIONS AND DISCHARGE SPECIFICATIONS

The CWA requires point source dischargers to control the amount of conventional, non-conventional, and toxic pollutants discharged into waters of the United States.

The control of pollutants discharged is established through effluent limitations and other requirements in NPDES permits. There are two principal bases for effluent limitations: 40 C.F.R. section 122.44(a) requires that permits include applicable technology-based limitations and standards, and 40 C.F.R. section 122.44(d) requires that permits include water quality-based effluent limitations to attain and maintain applicable numeric and narrative water quality criteria to protect the beneficial uses of receiving waters.

4.1. Discharge Prohibitions

4.1.1. Prohibitions in this Order

- 4.1.1.1. **Discharge Prohibition 3.1. (No discharge other than as described in NOI and Authorization to Discharge):** This prohibition is based on 40 C.F.R. section 122.21(a) and Water Code section 13260, which require filing an application and Report of Waste Discharge before a discharge can occur. Discharges not described in an NOI (application) and Authorization to Discharge, and subsequently in this Order, are prohibited.
- 4.1.1.2. **Discharge Prohibition 3.2. (No discharge of sanitary wastewater):** This prohibition is necessary because the requirements of this Order do not address sanitary wastewater. Sanitary wastewater discharges must meet secondary treatment standards and other requirements this Order does not impose.
- 4.1.1.3. **Discharge Prohibition 3.3. (No discharge of oil, residual products of petroleum, or other floating materials):** This prohibition is based on Basin Plan Table 4-1, Discharge Prohibitions 8 and 13, which prohibit the discharge of oil and other petroleum products, and other floating materials, to protect birds and other wildlife from possible toxic effects.
- 4.1.1.4. **Discharge Prohibition 3.4. (No treatment of pollutants shall create nuisance).** This prohibition is necessary to prevent the creation of nuisance conditions, as defined on Water Code section 13050.
- 4.1.1.5. **Discharge Prohibition 3.5. (No bypass to waters of United States).** This prohibition is based on 40 C.F.R. section 122.41(m) (see Attachment D section 1.7).

4.1.2. Basin Plan Discharge Prohibition 1

Basin Plan Table 4-1, Discharge Prohibition 1, prohibits the discharge of any wastewater that has particular characteristics of concern to beneficial uses at any point at which the wastewater does not receive a minimum initial dilution of at least 10:1, or into any nontidal water. This prohibition is intended to provide an added degree of protection from the continuous effect of discharges and provide a buffer against the effects of abnormal discharges caused by

temporary upsets or malfunctions. Basin Plan section 4.2 allows exceptions to Discharge Prohibition 1 in the following circumstances:

- An inordinate burden would be placed on the Discharger relative to the beneficial uses protected, and an equivalent level of environmental protection can be achieved by alternate means; or
- A discharge is approved as part of reclamation project; or
- A net environmental benefit will be derived as a result of the discharge; or
- A discharge is approved as part of a groundwater cleanup project, and in accordance with Resolution 88-160, “Regional Board Position on the Disposal of Extracted Groundwater from Groundwater Clean-up Projects,” it has been demonstrated that neither reclamation nor discharge to a publicly-owned treatment works is technically and economically feasible, and the Discharger has provided certification of the adequacy and reliability of treatment facilities and a plan that describes procedures for proper operation and maintenance of all treatment facilities.

The Basin Plan further states:

Significant factors to be considered by the Regional Water Board in reviewing requests for exceptions will be the reliability of the Discharger’s system in preventing inadequately treated wastewater from being discharged to the receiving water and the environmental consequences of such discharges.

This Order covers Dischargers performing groundwater extraction and cleanup. It requires Dischargers to document in their NOIs that neither reclamation nor discharge to a publicly-owned treatment works is technically and economically feasible. Additionally, sections 6.3.3, 6.3.4, and 6.3.5 of this Order require Dischargers to document how they will reliably prevent discharges of inadequately-treated wastewater as prohibited by Discharge Prohibition 3.5.

4.2. Technology-Based Effluent Limitations

4.2.1. Scope and Authority

CWA section 301(b) and 40 C.F.R. section 122.44 require that permits include conditions meeting technology-based requirements at a minimum, and any more stringent effluent limitations necessary to meet water quality standards. Regulations at 40 C.F.R. section 122.45 require that effluent limitations for continuous discharges other than publicly-owned treatment works be expressed as maximum daily and average monthly limitations, unless impracticable. The effluent limitations in this Order are practicable based on their development as described below. The CWA requires that technology-based effluent limitations (TBELs) be established based on several levels of control:

- **Best practicable treatment control technology (BPT).** BPT represents the average of the best existing performance by well-operated facilities within an industrial category or subcategory. BPT standards apply to toxic, conventional, and non-conventional pollutants.
- **Best available technology economically achievable (BAT).** BAT represents the best existing performance of treatment technologies that are economically achievable within an industrial point source category. BAT standards apply to toxic and non-conventional pollutants.
- **Best conventional pollutant control technology (BCT).** BCT represents the control from existing industrial point sources of conventional pollutants, including biochemical oxygen demand, total suspended solids, fecal coliform, pH, and oil and grease. BCT standards are established after considering the relationship between the cost of attaining a reduction in effluent discharge and the benefits that would result and the cost effectiveness of additional industrial treatment beyond BPT.
- **New source performance standards (NSPS).** NSPS represent the best available demonstrated control technology standards. The intent of NSPS guidelines is to set limitations that represent state-of-the-art treatment technology for new sources.

The CWA requires U.S. EPA to develop effluent limitations, guidelines, and standards representing the application of BPT, BAT, BCT, and NSPS. CWA section 402(a)(1) and 40 C.F.R. section 125.3 authorize the use of best professional judgment (BPJ) to derive technology-based effluent limitations on a case-by-case basis whenever U.S. EPA has not promulgated effluent limitations, guidelines, and standards. When BPJ is used, the Regional Water Board must consider specific factors listed in 40 C.F.R. section 125.3. U.S. EPA has not developed effluent limitations, guidelines, and standards for the types of discharges covered by this Order; therefore, all TBELs are based on the Basin Plan or BPJ. The TBELs based on BPJ reflect BPT and BAT. Since U.S. EPA has not developed effluent limitations, guidelines, and standards, NSPS does not apply.

4.2.2. **Applicable Limitations**

The table below lists the TBELs in this Order and their bases, which are described further below:

Table F-4. Technology-Based Effluent Limitations

Pollutants	Units	Maximum Daily Effluent Limit	Average Monthly Effluent Limit	Basis
pH	standard units	6.5-8.5	-	Basin Plan Table 4-2
Chlorine, Total Residual	mg/L	0.0	-	Basin Plan Table 4-2
Benzene	µg/L	0.50	-	BPJ (lowest SIP minimum level)
Chloroform	µg/L	1.9	-	BPJ (99 th percentile)
1,1-Dichloroethane	µg/L	0.50	-	BPJ (Lowest SIP minimum level)
1,2-Dichloroethane	µg/L	0.50	-	BPJ (Lowest SIP minimum level)
1,1-Dichloroethylene	µg/L	0.50	-	BPJ (Lowest SIP minimum level)
Ethylbenzene	µg/L	0.50	-	BPJ (Lowest SIP minimum level)
Tetrachloroethylene	µg/L	0.50	-	BPJ (Lowest SIP minimum level)
Toluene	µg/L	0.50	-	BPJ (Lowest SIP minimum level)
Cis-1,2-Dichloroethylene	µg/L	0.50	-	BPJ (Lowest SIP minimum level)
Trans-1,2-Dichloroethylene	µg/L	0.50	-	BPJ (Lowest SIP minimum level)
1,1,1-Trichloroethane	µg/L	0.50	-	BPJ (Lowest SIP minimum level)
1,1,2-Trichloroethane	µg/L	0.50	-	BPJ (Lowest SIP minimum level)
Trichloroethylene	µg/L	0.65	-	BPJ (99 th percentile)
Vinyl Chloride	µg/L	0.90	-	BPJ (99 th percentile)
Xylenes	µg/L	0.50	-	BPJ (Lowest reporting level)
Methyl Tertiary-butyl Ether	µg/L	0.50	-	BPJ (Lowest reporting level)
TPH as gasoline	µg/L	50.	-	BPJ (Lowest reporting level)
TPH as diesel	µg/L	50.	-	BPJ (99 th percentile)
TPH as motor oil	µg/L	100	-	BPJ (Lowest reporting level)
Per- and Polyfluoroalkyl Substances (PFAS)				
<i>Perfluorooctanoic acid (PFOA)</i>	ng/L	-	4.0	BPJ (MCL)
<i>Perfluorooctane sulfonic acid (PFOS)</i>	ng/L	-	4.0	BPJ (MCL)
<i>Perfluorohexane sulfonic acid (PFHxS)</i>	ng/L	-	10.	BPJ (MCL)
<i>Perfluorononanoic acid (PFNA)</i>	ng/L	-	10.	BPJ (MCL)

Pollutants	Units	Maximum Daily Effluent Limit	Average Monthly Effluent Limit	Basis
<i>Hexafluoropropylene oxide dimer acid (HFPO-DA)</i>	ng/L	-	10.	BPJ (MCL)

- 4.2.2.1. **pH.** This Order establishes an instantaneous minimum limit (6.5 standard units) and instantaneous maximum limit (8.5 standard units) for pH based on Basin Plan Table 4-2.
- 4.2.2.2. **Total Residual Chlorine.** This Order establishes an instantaneous maximum limit for total residual chlorine of 0.0 mg/L based on Basin Plan Table 4-2.
- 4.2.2.3. **Volatile Organic Compounds (VOCs) and Fuel-related Pollutants.** This Order establishes TBELs for VOCs and fuel-related pollutants based on BPJ, using all reasonably available and pertinent discharge data and information collected since 2015.

Class 4 Dischargers remove priority pollutants (e.g., VOCs, fuel-related compounds) using technologies such as air stripping and activated carbon. Nationwide, U.S. EPA reports that granular activated carbon adsorption (GAC) is the most used groundwater treatment method (Virginia State Water Control Board. *USEPA Model General Permit and the Fact Sheet for Permit No. VAG83*, December 1997). Air stripping and GAC, used separately or in conjunction with one another, can achieve pollutant removal efficiencies between 95 and 99.5 percent for groundwater pump-and-treat waste streams (U.S. EPA. *A Citizen's Guide to Activated Carbon Treatment*, USEPA 542-F-12-001, September 2012). When properly designed and operated, these treatment systems can lower the concentrations of all VOC and fuel-related pollutants for which this Order establishes TBELs to levels below analytical detection limits.

These TBELs are based on historical discharge data submitted by Dischargers between 2015 and 2016. The TBELs are the 99th percentile effluent concentration for each pollutant and are expressed as maximum daily effluent limitations. When the 99th percentile could only be estimated because it was below the corresponding reporting level or SIP minimum level, the TBEL selected was the lowest corresponding SIP minimum level or, if no SIP minimum level was available, the lowest corresponding reporting level found among available monitoring data.

The TBELs were derived from effluent data collected between 2015 and 2016 at 30 permitted facilities. The data were censored to include only the following:

- Effluent data from GAC treatment systems;

- Effluent data reported with corresponding influent data above method detection limits;
- Effluent data not exceeding previous effluent limitations, and
- Effluent data reported with corresponding reporting levels and method detection limits.

Although there have been occasional exceedances, Dischargers generally manage their treatment systems such that compliance with these TBELs is feasible; many Dischargers have never exceeded these concentrations. Data from the previous order term support that the Dischargers covered by this Order can achieve these TBELs.

- 4.2.2.4. **Per- and Polyfluoroalkyl Substances (PFAS).** For Class 4 discharges, this Order establishes TBELs for five PFAS based on BPJ using all reasonably available and pertinent data and information. PFAS are a group of synthetic chemicals used since the 1940s in a wide array of consumer and industrial products. Over the years, PFAS have been released into the air, soil, and surface and groundwaters. A growing body of scientific evidence shows that exposure at certain levels to specific PFAS can adversely impact human health and other living things (U.S. EPA. *PFAS Strategic Roadmap: EPA's Commitments to Action 2021-2024*, EPA-100-K-21-002, October 2021). Consequently, cleanup of PFAS contamination at cleanup sites and redevelopment areas with historical PFAS use is necessary to protect human health and the environment. This Order establishes PFAS TBELs to ensure that groundwater discharges do not harm surface water quality.

On April 10, 2024, U.S. EPA established MCLs for five PFAS: perfluorooctanoic acid (PFOA), perfluorooctane sulfonic acid (PFOS), perfluorohexane sulfonic acid (PFHxS), perfluorononanoic acid (PFNA), and hexafluoropropylene oxide dimer acid (HFPO-DA, also known as GenX). The MCLs were derived considering best available treatment technologies that include GAC, ion exchange resins, reverse osmosis, and nanofiltration (U.S. EPA. *Best Available Technologies and Small System Compliance Technologies for Per- and Polyfluoroalkyl Substances (PFAS) in Drinking Water*, EPA-815-R24011, March 2024). Class 4 Dischargers frequently use GAC and ion exchange resins to treat VOCs, fuel-related pollutants, and metals. As with VOCs and fuel leak compounds, GAC effectively treats many PFAS with removal efficiencies in the high 90 percent range, resulting in levels below analytical detection limits. As with GAC treatment, ion exchange resins, reverse osmosis, and nanofiltration also have high PFAS removal efficiencies (U.S. EPA. *Best Available Technologies and Small System Compliance Technologies for Per- and Polyfluoroalkyl Substances (PFAS) in Drinking Water*, EPA-815-R24011, March 2024). Thus, when properly designed and operated, these treatment technologies can lower PFAS concentrations sufficiently to meet MCLs. Therefore, this Order establishes

TBELs for Class 4 discharges based on MCLs for PFOA, PFOS, PFHxS, PFNA, and HFPO-DA. Because regional discharge data reflecting PFAS removal using these technologies is still somewhat limited, this Order establishes only average monthly TBELs, and not maximum daily TBELs, to account for potential treatment performance variation.

These PFAS TBELs do not apply to Class 1-3 Dischargers because Class 1-3 Dischargers do not currently employ treatment technologies that would remove PFAS. These Dischargers treat for non-priority pollutants, such as pH, hydrogen sulfide, total suspended solids, or low-level concentrations of naturally occurring metals using technologies (such as cartridge filters, ozone generators, or air spargers) that are ineffective for removing PFAS.

4.2.3. 40 C.F.R. Section 125.3(d) Factors

For the TBELs based on BPJ, the Regional Water Board considered the factors specified in 40 C.F.R. section 125.3(d) as described in the table below:

Table F-5. 40 C.F.R. Section 125.3(d) Factors

Factor	Considerations
Cost of applying technology relative to effluent reduction benefits	The cost of imposing these TBELs, which in most cases should be comparable to the cost of current technology Class 4 Dischargers employ to remove other pollutants, is reasonable given that existing Class 4 Dischargers already implement practicable and economically achievable treatment technologies and significant upgrades are unnecessary. Class 4 Dischargers that discharge PFAS will likely experience increased costs resulting from the addition and replacement of PFAS treatment media. These costs are warranted to minimize pollutant discharges; reduce exposure to the public and environment, and hold Class 4 Dischargers to the same performance.
Age of equipment and facilities	Nearly all Class 4 Dischargers already employ treatment technologies sufficient to comply with these TBELs, regardless of the age of their existing equipment and facilities.
Process employed	The processes most Class 4 Dischargers can employ to comply with these TBELs are readily available because Dischargers already employ treatment technologies sufficient to comply with these TBELs.
Engineering aspects of various controls	Nearly all Class 4 Dischargers already employ treatment technologies sufficient to comply with these TBELs; therefore, the engineering aspects of such technologies have been largely resolved. Available controls are practicable and capable of meeting the TBELs.
Process changes	Small or no changes to the treatment process are necessary because nearly all Class 4 Dischargers already employ treatment technologies sufficient to comply with these TBELs. Treating for PFAS will likely result in

Factor	Considerations
	process changes for the frequency of replacement for GAC and ion-exchange resins.
Non-water quality environmental impacts	Non-water quality environmental impacts are likely because Class 4 Dischargers that discharge PFAS may need to add and replace PFAS treatment media. These impacts may include increased energy consumption and greenhouse emissions due to treatment media consumption, transportation, and installation. The magnitude of these impacts, however, are site-specific and largely depend on groundwater quality and distances to PFAS media supply and disposal centers.

4.3. Water Quality-Based Effluent Limitations

4.3.1. Scope and Authority

CWA section 301(b) and 40 C.F.R. section 122.44(d) require permits to include limitations more stringent than federal technology-based requirements where necessary to achieve water quality standards. According to 40 C.F.R. section 122.44(d)(1)(i), permits must include effluent limitations for all pollutants that are or may be discharged at levels that have a reasonable potential to cause or contribute to an exceedance of a water quality standard, including numeric and narrative objectives within a standard. Where reasonable potential has been established for a pollutant, but there is no numeric criterion or objective, water quality-based effluent limitations (WQBELs) must be established using (1) U.S. EPA criteria guidance under CWA section 304(a), supplemented where necessary by other relevant information; (2) an indicator parameter for the pollutant of concern; or (3) a calculated numeric water quality criterion, such as a proposed state criterion or policy interpreting a narrative criterion, supplemented with relevant information. The process for determining reasonable potential and calculating WQBELs when necessary is intended to achieve applicable water quality objectives and criteria, and thereby protect designated beneficial uses of receiving waters. This Order imposes WQBELs for pollutants with reasonable potential to cause or contribute to exceedances of water quality standards. Regulations at 40 C.F.R. section 122.45 require that effluent limitations for discharges other than publicly-owned treatment works be expressed as maximum daily and average monthly limitations, unless impracticable. The effluent limitations in this Order are practicable based on their development as described in Fact Sheet sections 4.3.3 and 4.3.4.

4.3.2. Beneficial Uses and Water Quality Criteria and Objectives

Fact Sheet section 3.3.1 identifies the potential beneficial uses of the receiving waters for discharges subject to this Order. Water quality criteria and objectives to protect these beneficial uses are described below:

- 4.3.2.1. **Basin Plan Objectives.** The Basin Plan specifies numeric water quality objectives for many pollutants to protect aquatic life (see Basin Plan

section 3.3.21). It also specifies narrative water quality objectives, such as the narrative toxicity objective: “All waters shall be maintained free of toxic substances in concentrations that are lethal to or that produce other detrimental responses in aquatic organisms.”

- 4.3.2.2. **CTR Criteria.** The CTR specifies numeric aquatic life and human health criteria for numerous priority pollutants. These criteria apply to inland surface waters and enclosed bays and estuaries. Some human health criteria are for consumption of “water and organisms” and others are for consumption of “organisms only.” Waters with municipal or domestic supply beneficial use designation are subject to the “water and organisms” criteria.
- 4.3.2.3. **NTR Criteria.** The NTR establishes numeric aquatic life and human health criteria for a number of toxic pollutants for San Francisco Bay waters upstream to and including Suisun Bay and the Sacramento-San Joaquin Delta.
- 4.3.2.4. **Toxicity Provisions.** The Toxicity Provisions establish numeric chronic and acute toxicity objectives that apply to all inland surface waters, enclosed bays, and estuaries in the State with aquatic life beneficial uses. The chronic toxicity water quality objective is as follows:

H_o : Mean Response (ambient water) $\leq 0.75 \times$ Mean Response (control water)

H_a : Mean Response (ambient water) $> 0.75 \times$ Mean Response (control water)

Where:

H_o = Null Hypothesis

H_a = Alternative Hypothesis

0.75 = Regulatory Management Decision criterion (i.e., 75 percent)

H_o means the ambient water is toxic when the test organism response in a bioassay is less than or equal to 75 percent of the control response;

H_a means the ambient water is not toxic when the test organism response is greater than 75 percent of the control response. For example, if an average of 75 percent of bioassay test organisms or fewer survive when exposed to ambient water relative to the average number that survive when exposed to control water, the ambient water is toxic (i.e., the test result is “fail”).

Conversely, if an average of more than 75 percent of bioassay test organisms survive relative to those exposed to control water, the ambient water is not toxic (i.e., the test result is “pass”).

- 4.3.2.5. **Sediment Quality Objectives.** The *Water Quality Control Plan for Enclosed Bays and Estuaries – Part 1, Sediment Quality* contains the following narrative water quality objectives:
- 4.3.2.5.1. “Pollutants in sediments shall not be present in quantities that, alone or in combination, are toxic to benthic communities in bays and estuaries of

California.” This objective is to be implemented by integrating three lines of evidence: sediment toxicity, benthic community condition, and sediment chemistry. The policy requires that if the Regional Water Board determines that a discharge has reasonable potential to cause or contribute to an exceedance of this objective, it is to impose the objective as a receiving water limit.

- 4.3.2.5.2. “Pollutants shall not be present in sediments at levels that will bioaccumulate in aquatic life to levels that are harmful to human health in bays and estuaries of California.” This objective is to be implemented by a three-tiered procedure based on pollutant concentrations in sediment and fish tissue.
- 4.3.2.5.3. “Pollutants shall not be present in sediment at levels that alone or in combination are toxic to wildlife and resident finfish by direct exposure or bioaccumulate in aquatic life at levels that are harmful to wildlife or resident finfish by indirect exposure in bays and estuaries of California.” This objective is to be implemented on a case-by-case basis, based upon an ecological risk assessment.
- 4.3.2.6. **Receiving Water Salinity.** Basin Plan section 4.6.2 (like the CTR and NTR) states that the salinity characteristics (i.e., freshwater vs. saltwater) of the receiving water are to be considered in determining the applicable water quality objectives. Freshwater criteria apply to discharges to waters with salinities equal to or less than one part per thousand (ppt) at least 95 percent of the time. Saltwater criteria apply to discharges to waters with salinities equal to or greater than 10 ppt at least 95 percent of the time in a normal water year. For discharges to water with salinities in between these two categories, or tidally influenced freshwaters that support estuarine beneficial uses, the water quality objectives are the lower of the salt or freshwater criteria (the latter calculated based on ambient hardness) for each substance.

Receiving waters for the discharges this Order covers include San Francisco Bay, estuarine and tidally-influenced waters, and inland freshwaters. In most cases, the reasonable potential analyses and WQBELs are based on the most stringent of freshwater and saltwater criteria to fully protect all receiving waters. The reasonable potential analyses for copper and nickel also include analyses for discharges to freshwater, where saltwater criteria do not apply.

The Basin Plan implements State Water Resolution 88-63, which establishes State policy that all waters, with certain exceptions, should be considered suitable or potentially suitable for municipal or domestic supply (MUN). Because of the marine influence of all reaches of San Francisco Bay and other tidally influenced waters, total dissolved solids levels exceed 3,000 mg/L and thereby meet an exception of State Water Resolution 88-63.

Therefore, water with and without MUN designation are considered separately below with respect to the need for, and calculation of, WQBELs.

- 4.3.2.7. **Receiving Water Hardness.** Some freshwater objectives for metals are hardness dependent (as hardness increases, the toxicity of certain metals decreases). In determining the freshwater water quality objectives that depend on hardness, a hardness value of 100 mg/L as CaCO₃ was used, which is conservative and generally protective of aquatic life in all circumstances contemplated by this permit. Mean and median hardness data collected through the Surface Water Ambient Monitoring Program are 250 mg/L and 232 mg/L. Values less than 100 mg/L were found primarily in Marin County, where dewatering activities rarely occur.
- 4.3.2.8. **Metals Translators.** NPDES regulations at 40 C.F.R. 122.45(c) require that effluent limitations for metals be expressed as total recoverable metal. Since water quality objectives for metals are typically expressed as dissolved metal, translators must be used to convert metals concentrations from dissolved to total recoverable and vice versa. The CTR includes default translators; however, site-specific conditions, such as water temperature, pH, suspended solids, and organic carbon affect the form of metal (dissolved, non-filterable, or otherwise) present in the water and therefore available to cause toxicity. In general, the dissolved form of the metal is more available and more toxic to aquatic life than non-filterable forms. Metals translators can be developed to account for site-specific conditions, thereby preventing exceedingly stringent or under protective water quality objectives.

This Order covers discharges to various receiving waters; therefore, site-specific conditions vary. CTR default translators were used for all metals, except for copper and nickel within the context of San Francisco Bay. The Suisun Bay, San Pablo Bay, Central San Francisco Bay, and Lower San Francisco Bay translators specified in Basin Plan Table 7.2.1-2 were used for copper. The South San Francisco Bay translators specified in Basin Plan Table 7.2.1-1 were used for copper and nickel. The North and Central San Francisco Bay translators for nickel recommended by the Clean Estuary Partnership's North of Dumbarton Bridge Copper and Nickel Development and Selection of Final Translators (2005) were used for Suisun Bay, San Pablo Bay, Central San Francisco Bay, and Lower San Francisco Bay.

Table F-6. Copper and Nickel Translators

San Francisco Bay Segment	Copper AMEL Translator	Copper MDEL Translator	Nickel AMEL Translator	Nickel MDEL Translator
Suisun Bay and San Pablo Bay	0.38	0.66	0.27	0.57
Central and Lower San Francisco Bays	0.73	0.87	0.65	0.85
South San Francisco Bay	0.53	0.53	0.44	0.44

4.3.3. Reasonable Potential Analysis

- 4.3.3.1. **Available Information.** The reasonable potential analysis for this Order is based on effluent data from 2019 through 2023 from approximately 100 facilities enrolled under the previous orders. Effluent data from Class 1 discharges are unavailable because no dischargers in this class enrolled in the previous orders. This Order does not contain WQBELs for constituents that do not demonstrate reasonable potential; however, the MRP still requires monitoring for these pollutants.
- 4.3.3.2. **Methodology.** SIP section 1.3 set forth the methodology used to assess whether a priority pollutant has reasonable potential to exceed a water quality objective. SIP section 1.3 applies to priority pollutants and is used here for non-priority pollutants as guidance. SIP section 1.3 sets forth the methodology used for priority pollutants to assess whether they have reasonable potential to exceed water quality objectives. The analysis begins with identifying the maximum effluent concentration (MEC) observed for each pollutant based on available effluent concentration data and the ambient background concentration (B). SIP section 1.4.3 states that ambient background concentrations are either the maximum ambient concentration observed or, for water quality objectives intended to protect human health, the arithmetic mean of observed concentrations. Ambient background concentrations were not considered for this analysis because most discharges covered by this Order commingle with others in storm drains before reaching varied receiving waters. There are three triggers in determining reasonable potential:
- 4.3.3.2.1. **Trigger 1** is activated if the maximum effluent concentration is greater than or equal to the lowest applicable water quality criterion ($MEC \geq$ water quality criterion).
- 4.3.3.2.2. **Trigger 2** is activated if the ambient background concentration observed in the receiving water is greater than the water quality criterion ($B >$ water quality criterion) and the pollutant is detected in any effluent sample.
- 4.3.3.2.3. **Trigger 3** is activated if a review of other information indicates that a WQBEL is needed to protect beneficial uses.
- 4.3.3.3. **Analyses.** For Class 1 discharges, reasonable potential analysis was not performed because no effluent data were available. However, aquifer well discharges are not assumed to contain pollutants above water quality objectives because they originate in the vicinity of drinking water supply aquifers that are not expected to be contaminated; therefore, there is no reasonable potential for these discharges to cause or contribute to exceedances of water quality objectives.

For Class 2, 3, and 4 discharges, separate reasonable potential analyses were conducted. The maximum effluent concentrations for detected parameters and most stringent applicable water quality criteria are presented in the following tables, along with the analysis results (yes or no) for each pollutant. Reasonable potential was not determined for pollutants where water quality criteria have not been developed or monitoring data are unavailable. When additional data become available for pollutants applicable to the discharges covered by this Order, further analysis will be conducted to determine whether WQBELs are necessary.

Based on the review of effluent data from Class 2 and Class 3 Dischargers, this Order finds reasonable potential for cadmium, copper, lead, and nickel by Trigger 1. For Class 4 Dischargers, this Order finds reasonable potential for antimony, arsenic, cadmium, chromium(VI), copper, lead, mercury, nickel, silver, thallium, zinc, cyanide, dichlorobromomethane, 1,2-dichloroethane, methylene chloride, tetrachloroethylene, trichloroethylene, vinyl chloride, 2,4-dichlorophenol, 2,4,6-trichlorophenol, benzidine, bis(2-chloroethyl)ether, 1,2-diphenylhydrazine, 1,2,4-trichlorobenzene, and methyl tertiary-butyl ether by Trigger 1. Effluent data do not indicate an exceedance of water quality criteria for vinyl chloride; however, this Order finds reasonable potential for vinyl chloride by Trigger 3 because it is one of the least treatable VOCs in groundwater and could appear in treated effluent.

This Order also finds reasonable potential for selenium by Trigger 3 for discharges to Stevens Creek, a freshwater creek in Santa Clara County. This reasonable potential analysis is based on discharge data from currently enrolled Dischargers, whole-body fish tissue data, and a recently developed and promulgated U.S. EPA freshwater water quality criterion that protects aquatic life and aquatic-dependent wildlife from chronic exposure to toxic levels of selenium. The criterion consists of bird tissue, fish tissue, and water column elements in which the bird and fish tissue elements supersede the water column element when tissue and water column data are available.¹

During the previous order term, seven Dischargers exceeded the water column criterion element in their discharges, which discharged to Stevens Creek and Guadalupe River in Santa Clara County. In November 2023, 35 whole-body fish tissue samples were collected in Stevens Creek and Guadalupe River to determine reasonable potential by these Dischargers (Robertson-Bryan, Inc., *Fish Tissue Selenium Monitoring in Santa Clara County*, June 2024). In Guadalupe River, all whole-body fish tissue samples

¹ Environmental Protection Agency. (2024, December 17). The Federal Register. Water Quality Standards; Establishment of a Numeric Criterion for Selenium for the State of California. <https://www.federalregister.gov/documents/2024/12/17/2024-29483/water-quality-standards-establishment-of-a-numeric-criterion-for-selenium-for-the-state-of>

were below the whole-body fish tissue criterion element of 8.5 milligrams per kilogram (mg/kg) by dry weight; therefore, there is no reasonable potential for discharges to Guadalupe River. In Stevens Creek, three whole-body fish tissue samples exceeded the whole-body fish tissue criterion element at 9.1 mg/kg, 10.6 mg/kg, and 11.1 mg/kg by dry weight; therefore, there is reasonable potential for discharges to Stevens Creek. For all other freshwater receiving waters that receive discharges covered by this Order, there are no applicable tissue data to evaluate reasonable potential. However, all discharge data for these receiving waters were below the selenium criterion's applicable water column elements; therefore, there is no reasonable potential for these receiving waters, and reasonable potential for potentially new receiving waters covering future enrollees during this Order term is unknown. To support future reasonable potential analyses for discharges to other receiving waters, this Order includes selenium discharge monitoring requirements (see MRP section 3.3).

Monitoring data for all applicable municipal supply pollutants with primary MCLs is unavailable. Therefore, a comprehensive reasonable potential analysis for those pollutants could not be conducted. As such, this Order requires monitoring for all applicable municipal supply pollutants with primary MCLs for discharges to receiving waters with the "Municipal and Domestic Supply" or "Groundwater Recharge" beneficial uses.

There is no reasonable potential for municipal supply pollutants with secondary MCLs, and these pollutants are excluded from Tables F-7 and F-8, below. Secondary MCLs are aesthetic standards intended to protect the public from undesirable taste, odor, or appearance in drinking water. The discharges covered by this Order are not expected to cause or contribute to exceedances of secondary MCLs because the filtration treatment required for raw surface water prior to public distribution removes these pollutants. Moreover, secondary MCLs apply as long-term (annual) averages, and many discharges covered by this Order are not expected to occur continuously for over a year.

Table F-7. Reasonable Potential Analysis – Classes 1, 2, and 3

CTR No.	Pollutant	Unit	C or Governing Criterion or Objective (µg/L)	MEC or Minimum DL (µg/L) ^{[1],[2]}	RPA Result ^[3]
1	Antimony	µg/L	6.0	0.37	No
2	Arsenic	µg/L	10	6.4	No
3	Beryllium	µg/L	4.0	0.52	No
4	Cadmium	µg/L	1.1	1.3	Yes
5a	Chromium (III)	µg/L	50	2.2	No
5b	Chromium (VI)	µg/L	10	5.6	No
6	Copper				
	South SF Bay Discharge	µg/L	13	110	Yes

CTR No.	Pollutant	Unit	C or Governing Criterion or Objective ($\mu\text{g/L}$)	MEC or Minimum DL ($\mu\text{g/L}$) ^{[1],[2]}	RPA Result ^[3]
	Central and Lower SF Bay Discharge	$\mu\text{g/L}$	8.2	110	Yes
	Suisun or San Pablo Bay Discharge	$\mu\text{g/L}$	14	110	Yes
	Freshwater Discharge	$\mu\text{g/L}$	9.3	110	Yes
7	Lead	$\mu\text{g/L}$	3.2	3.5	Yes
8	Mercury	$\mu\text{g/L}$	0.05	0.006	No
9	Nickel				
	South SF Bay Discharge	$\mu\text{g/L}$	27	110	Yes
	Central and Lower SF Bay Discharge	$\mu\text{g/L}$	13	110	Yes
	Suisun or San Pablo Bay Discharge	$\mu\text{g/L}$	30	110	Yes
	Freshwater Discharge	$\mu\text{g/L}$	8.3	110	Yes
10	Selenium	$\mu\text{g/L}$	^[4]	23	Yes
11	Silver	$\mu\text{g/L}$	2.2	1.1	No
12	Thallium	$\mu\text{g/L}$	1.7	0.68	No
13	Zinc	$\mu\text{g/L}$	86	64	No
14	Cyanide	$\mu\text{g/L}$	2.9	2.6	No
15	Asbestos (fibers/L)	$\mu\text{g/L}$	7.0×10^6	Unavailable	U
16	2,3,7,8-TCDD	$\mu\text{g/L}$	1.3×10^{-8}	<0.00001	U
17	Acrolein	$\mu\text{g/L}$	320	<5.0	No
18	Acrylonitrile	$\mu\text{g/L}$	0.059	<2.0	U
19	Benzene	$\mu\text{g/L}$	1	<1.0	No
20	Bromoform	$\mu\text{g/L}$	4.3	2.1	No
21	Carbon Tetrachloride	$\mu\text{g/L}$	0.25	<1.0	U
22	Chlorobenzene	$\mu\text{g/L}$	70	<1.0	No
23	Chlorodibromomethane	$\mu\text{g/L}$	0.40	<0.15	No
24	Chloroethane	$\mu\text{g/L}$	No Criteria	<1.0	U
25	2-Chloroethylvinyl ether	$\mu\text{g/L}$	No Criteria	<1.0	U
26	Chloroform	$\mu\text{g/L}$	No Criteria	2.1	U
27	Dichlorobromomethane	$\mu\text{g/L}$	0.56	<0.05	No
28	1,1-Dichloroethane	$\mu\text{g/L}$	5.0	<1.0	No
29	1,2-Dichloroethane	$\mu\text{g/L}$	0.38	<1.0	U
30	1,1-Dichloroethylene	$\mu\text{g/L}$	0.057	<1.0	U
31	1,2-Dichloropropane	$\mu\text{g/L}$	0.52	<1.0	U
32	1,3-Dichloropropylene	$\mu\text{g/L}$	0.50	<1.0	U
33	Ethylbenzene	$\mu\text{g/L}$	300	<1.0	No
34	Methyl Bromide	$\mu\text{g/L}$	48	<0.5	No
35	Methyl Chloride	$\mu\text{g/L}$	No Criteria	<0.5	U
36	Methylene Chloride	$\mu\text{g/L}$	4.7	<1.0	No
37	1,1,2,2-Tetrachloroethane	$\mu\text{g/L}$	0.17	<0.015	No
38	Tetrachloroethylene	$\mu\text{g/L}$	0.80	<0.2	No

CTR No.	Pollutant	Unit	C or Governing Criterion or Objective (µg/L)	MEC or Minimum DL (µg/L) ^{[1],[2]}	RPA Result ^[3]
39	Toluene	µg/L	150	<0.1	No
40	1,2-Trans-Dichloroethylene	µg/L	10	<0.5	No
41	1,1,1-Trichloroethane	µg/L	200	<0.13	No
42	1,1,2-Trichloroethane	µg/L	0.6	<0.032	No
43	Trichloroethylene	µg/L	2.7	<0.2	No
44	Vinyl Chloride	µg/L	0.50	0.0044	No
45	2-Chlorophenol	µg/L	120	Unavailable	No
46	2,4-Dichlorophenol	µg/L	93	<0.0053	No
47	2,4-Dimethylphenol	µg/L	540	<0.5	No
48	2-Methyl- 4,6-Dinitrophenol	µg/L	13.4	<3.5	No
49	2,4-Dinitrophenol	µg/L	70	<0.65	No
50	2-Nitrophenol	µg/L	No Criteria	180	U
51	4-Nitrophenol	µg/L	No Criteria	170	U
52	3-Methyl 4-Chlorophenol	µg/L	No Criteria	2.6	U
53	Pentachlorophenol	µg/L	0.28	<0.15	No
54	Phenol	µg/L	21,000	<0.018	No
55	2,4,6-Trichlorophenol	µg/L	2.1	<0.005	No
56	Acenaphthene	µg/L	1,200	0.0044	No
57	Acenaphthylene	µg/L	No Criteria	<0.0017	U
58	Anthracene	µg/L	9,600	<0.0006	No
59	Benzidine	µg/L	0.00012	<2.6	U
60	Benzo(a)Anthracene	µg/L	0.0044	<0.003	No
61	Benzo(a)Pyrene	µg/L	0.0044	<0.003	No
62	Benzo(b)Fluoranthene	µg/L	0.0044	<0.002	No
63	Benzo(ghi)Perylene	µg/L	No Criteria	<0.001	U
64	Benzo(k)Fluoranthene	µg/L	0.0044	<0.001	No
65	Bis(2-Chloroethoxy)Methane	µg/L	No Criteria	<0.49	U
66	Bis(2-Chloroethyl)Ether	µg/L	0.031	<0.0048	No
67	Bis(2-Chloroisopropyl)Ether	µg/L	1,400	<0.0047	No
68	Bis(2-Ethylhexyl)Phthalate	µg/L	1.8	24	U ^[5]
69	4-Bromophenyl Phenyl Ether	µg/L	No Criteria	<0.28	U
70	Butylbenzyl Phthalate	µg/L	3,000	<0.077	No
71	2-Chloronaphthalene	µg/L	1,700	<0.53	No
72	4-Chlorophenyl Phenyl Ether	µg/L	No Criteria	<0.47	U
73	Chrysene	µg/L	0.0044	<0.0008	No
74	Dibenz(a,h)Anthracene	µg/L	0.0044	<0.002	No
75	1,2-Dichlorobenzene	µg/L	600	<0.2	No
76	1,3-Dichlorobenzene	µg/L	400	<0.2	No
77	1,4-Dichlorobenzene	µg/L	5.0	<0.2	No
78	3,3 Dichlorobenzidine	µg/L	0.040	<0.0059	No
79	Diethyl Phthalate	µg/L	23,000	<0.02	No
80	Dimethyl Phthalate	µg/L	313,000	0.024	No

CTR No.	Pollutant	Unit	C or Governing Criterion or Objective (µg/L)	MEC or Minimum DL (µg/L) ^{[1],[2]}	RPA Result ^[3]
81	Di-n-Butyl Phthalate	µg/L	2,700	<0.074	No
82	2,4-Dinitrotoluene	µg/L	0.11	<0.026	No
83	2,6-Dinitrotoluene	µg/L	No Criteria	<0.029	U
84	Di-n-Octyl Phthalate	µg/L	No Criteria	<0.6	U
85	1,2-Diphenylhydrazine	µg/L	0.04	<0.4	U
86	Fluoranthene	µg/L	300	<0.0006	No
87	Fluorene	µg/L	1,300	<0.0017	No
88	Hexachlorobenzene	µg/L	0.00075	<0.0016	No
89	Hexachlorobutadiene	µg/L	0.44	<0.001	No
90	Hexachlorocyclopentadiene	µg/L	1.0	<2.2	U
91	Hexachloroethane	µg/L	1.9	<0.0032	No
92	Indeno(1,2,3-cd)Pyrene	µg/L	0.0044	<0.001	No
93	Isophorone	µg/L	8.4	<0.3	No
94	Naphthalene	µg/L	No Criteria	<0.57	U
95	Nitrobenzene	µg/L	17	<0.34	No
96	N-Nitrosodimethylamine	µg/L	0.00069	<0.0034	U
97	N-Nitrosodi-n-Propylamine	µg/L	0.0050	<0.0008	No
98	N-Nitrosodiphenylamine	µg/L	5.0	<0.2	No
99	Phenanthrene	µg/L	No Criteria	<0.005	U
100	Pyrene	µg/L	960	<0.01	No
101	1,2,4-Trichlorobenzene	µg/L	5.0	<0.005	No
102	Aldrin	µg/L	0.00013	<0.02	U
103	Alpha-BHC	µg/L	0.0039	<0.005	U
104	Beta-BHC	µg/L	0.014	<0.1	U
105	Gamma-BHC	µg/L	0.019	<0.01	No
106	Delta-BHC	µg/L	No Criteria	<0.01	U
107	Chlordane	µg/L	0.00057	<0.01	U
108	4,4'-DDT	µg/L	0.00059	<0.01	U
109	4,4'-DDE	µg/L	0.00059	<0.01	U
110	4,4'-DDD	µg/L	0.00083	<0.01	U
111	Dieldrin	µg/L	0.00014	<0.01	U
112	Alpha-Endosulfan	µg/L	0.0087	<0.02	U
113	beta-Endosulfan	µg/L	0.0087	<0.02	U
114	Endosulfan Sulfate	µg/L	110	<0.05	No
115	Endrin	µg/L	0.0023	<0.01	U
116	Endrin Aldehyde	µg/L	0.76	<0.05	No
117	Heptachlor	µg/L	0.00021	<0.01	U
118	Heptachlor Epoxide	µg/L	0.00010	<0.01	U
119-125	PCBs sum	µg/L	0.00017	<0.5	U
126	Toxaphene	µg/L	0.00020	<0.5	U

Footnotes:

^[1] The MEC and ambient background concentration are the actual detected concentrations unless preceded by a "<" sign, in which case the value shown is the minimum detection level (MDL).

^[2] The MEC or ambient background concentration is "Unavailable" when there are no monitoring data for the constituent.

^[3] RPA Results = Yes, if MEC ≥ WQC, B > WQC and MEC is detected, or Trigger 3

= No, if MEC and B are < WQC or all effluent data are undetected

= Unknown (U) if no criteria have been promulgated or data are insufficient.

^[4] Reasonable potential analysis is based on Trigger 3 considering U.S. EPA's freshwater selenium criterion whole-body fish tissue element of 8.5 mg/kg by dry weight. Reasonable potential was found for discharges to Stevens Creek in Santa Clara County only.

^[5] Bis(2-ethylhexyl)phthalate is a common laboratory contaminant and is not anticipated to be a pollutant of concern for the types of discharges this Order allows. This Order requires sampling for bis(2-ethylhexyl)phthalate to be performed using ultra clean sampling techniques for re-evaluation during future permit reissuance.

Table F-8. Reasonable Potential Analysis – Class 4

CTR No.	Pollutant	Unit	C or Governing Criterion or Objective (µg/L)	MEC or Minimum DL (µg/L) ^{[1],[2]}	RPA Result ^[3]
1	Antimony	µg/L	6.0	26	Yes
2	Arsenic	µg/L	10	38	Yes
3	Beryllium	µg/L	4.0	<0.0001	No
4	Cadmium	µg/L	1.1	24	Yes
5a	Chromium (III)	µg/L	50	12.83	No
5b	Chromium (VI)	µg/L	10	33	Yes
6	Copper				
	<i>South SF Bay Discharge</i>	µg/L	13	230	Yes
	<i>Central and Lower SF Bay Discharge</i>	µg/L	8.2	230	Yes
	<i>Suisun or San Pablo Bay Discharge</i>	µg/L	14.2	230	Yes
	<i>Freshwater Discharge</i>	µg/L	7.2	230	Yes
7	Lead	µg/L	3.2	27	Yes
8	Mercury	µg/L	0.05	18	Yes
9	Nickel				
	<i>South SF Bay Discharge</i>	µg/L	27	79	Yes
	<i>Central and Lower SF Bay Discharge</i>	µg/L	13	79	Yes
	<i>Suisun or San Pablo Bay Discharge</i>	µg/L	30	79	Yes
	<i>Freshwater Discharge</i>	µg/L	8	79	Yes
10	Selenium	µg/L	^[4]	19 ^[5]	Yes
11	Silver	µg/L	2.2	26	Yes
12	Thallium	µg/L	1.7	8.0	Yes
13	Zinc	µg/L	86	1400	Yes
14	Cyanide	µg/L	5.2	34	Yes
15	Asbestos (fibers/L)	µg/L	7.0 x 10 ⁶	Unavailable	U
16	2,3,7,8-TCDD	µg/L	1.3 x 10 ⁻⁸	Unavailable	U
17	Acrolein	µg/L	320	12.4	No
18	Acrylonitrile	µg/L	0.059	<0.671	U

CTR No.	Pollutant	Unit	C or Governing Criterion or Objective (µg/L)	MEC or Minimum DL (µg/L) ^{[1],[2]}	RPA Result ^[3]
19	Benzene	µg/L	1	<0.031	No
20	Bromoform	µg/L	4.3	1.9	No
21	Carbon Tetrachloride	µg/L	0.25	<0.025	No
22	Chlorobenzene	µg/L	70	0.5	No
23	Chlorodibromomethane	µg/L	0.40	<0.022	No
24	Chloroethane	µg/L	No Criteria	2.4	U
25	2-Chloroethylvinyl ether	µg/L	No Criteria	5.0	U
26	Chloroform	µg/L	No Criteria	37	U
27	Dichlorobromomethane	µg/L	0.56	0.60	Yes
28	1,1-Dichloroethane	µg/L	5.0	4.0	No
29	1,2-Dichloroethane	µg/L	0.38	57	Yes
30	1,1-Dichloroethylene	µg/L	0.057	<0.0036	No
31	1,2-Dichloropropane	µg/L	0.52	0.5	No
32	1,3-Dichloropropylene	µg/L	0.50	<0.025	No
33	Ethylbenzene	µg/L	700	14	No
34	Methyl Bromide	µg/L	48	1.0	No
35	Methyl Chloride	µg/L	No Criteria	1.0	U
36	Methylene Chloride	µg/L	4.7	14	Yes
37	1,1,2,2-Tetrachloroethane	µg/L	0.17	<0.11	No
38	Tetrachloroethylene	µg/L	0.80	4.9	Yes
39	Toluene	µg/L	150	37	No
40	1,2-Trans-Dichloroethylene	µg/L	10	1.1	No
41	1,1,1-Trichloroethane	µg/L	200	1.3	No
42	1,1,2-Trichloroethane	µg/L	0.6	0.5	No
43	Trichloroethylene	µg/L	2.7	2.9	Yes
44	Vinyl Chloride	µg/L	0.50	0.0027	Yes
45	2-Chlorophenol	µg/L	120	3.8	No
46	2,4-Dichlorophenol	µg/L	93	210	Yes
47	2,4-Dimethylphenol	µg/L	540	53	No
48	2-Methyl- 4,6-Dinitrophenol	µg/L	13.4	12	No
49	2,4-Dinitrophenol	µg/L	70	41	No
50	2-Nitrophenol	µg/L	No Criteria	180	U
51	4-Nitrophenol	µg/L	No Criteria	170	U
52	3-Methyl 4-Chlorophenol	µg/L	No Criteria	2.6	U
53	Pentachlorophenol	µg/L	0.28	<0.051	No
54	Phenol	µg/L	21,000	6.1	No
55	2,4,6-Trichlorophenol	µg/L	2.1	2.9	No
56	Acenaphthene	µg/L	1,200	3	No
57	Acenaphthylene	µg/L	No Criteria	3.8	U
58	Anthracene	µg/L	9,600	3.2	No
59	Benzidine	µg/L	0.00012	260	Yes
60	Benzo(a)Anthracene	µg/L	0.0044	0.0012	No

CTR No.	Pollutant	Unit	C or Governing Criterion or Objective (µg/L)	MEC or Minimum DL (µg/L) ^{[1],[2]}	RPA Result ^[3]
61	Benzo(a)Pyrene	µg/L	0.0044	0.0013	No
62	Benzo(b)Fluoranthene	µg/L	0.0044	0.0011	No
63	Benzo(ghi)Perylene	µg/L	No Criteria	2.9	U
64	Benzo(k)Fluoranthene	µg/L	0.0044	<0.0011	No
65	Bis(2-Chloroethoxy)Methane	µg/L	No Criteria	27	U
66	Bis(2-Chloroethyl)Ether	µg/L	0.031	11	Yes
67	Bis(2-Chloroisopropyl)Ether	µg/L	1,400	6.6	No
68	Bis(2-Ethylhexyl)Phthalate	µg/L	1.8	698	U ^[6]
69	4-Bromophenyl Phenyl Ether	µg/L	No Criteria	16	U
70	Butylbenzyl Phthalate	µg/L	3,000	30	No
71	2-Chloronaphthalene	µg/L	1,700	24	No
72	4-Chlorophenyl Phenyl Ether	µg/L	No Criteria	24	U
73	Chrysene	µg/L	0.0044	3.0	Yes
74	Dibenzo(a,h)Anthracene	µg/L	0.0044	<0.00099	No
75	1,2-Dichlorobenzene	µg/L	600	18	No
76	1,3-Dichlorobenzene	µg/L	400	30	No
77	1,4-Dichlorobenzene	µg/L	5.0	<0.068	No
78	3,3 Dichlorobenzidine	µg/L	0.040	13	No
79	Diethyl Phthalate	µg/L	23,000	9.3	No
80	Dimethyl Phthalate	µg/L	313,000	17	No
81	Di-n-Butyl Phthalate	µg/L	2,700	74	No
82	2,4-Dinitrotoluene	µg/L	0.11	22	Yes
83	2,6-Dinitrotoluene	µg/L	No Criteria	23	U
84	Di-n-Octyl Phthalate	µg/L	No Criteria	83	U
85	1,2-Diphenylhydrazine	µg/L	0.04	22	Yes
86	Fluoranthene	µg/L	300	3.3	No
87	Fluorene	µg/L	1,300	3.8	No
88	Hexachlorobenzene	µg/L	0.00075	3.2	Yes
89	Hexachlorobutadiene	µg/L	0.44	<0.0048	No
90	Hexachlorocyclopentadiene	µg/L	1.0	<0.05	No
91	Hexachloroethane	µg/L	1.9	<0.0028	No
92	Indeno(1,2,3-cd)Pyrene	µg/L	0.0044	<0.0014	No
93	Isophorone	µg/L	8.4	<0.01	No
94	Naphthalene	µg/L	No Criteria	5.0	U
95	Nitrobenzene	µg/L	17	<0.05	No
96	N-Nitrosodimethylamine	µg/L	0.00069	<0.05	U
97	N-Nitrosodi-n-Propylamine	µg/L	0.0050	<0.05	U
98	N-Nitrosodiphenylamine	µg/L	5.0	<0.05	No
99	Phenanthrene	µg/L	No Criteria	3.1	U
100	Pyrene	µg/L	960	3.1	No
101	1,2,4-Trichlorobenzene	µg/L	5.0	10	Yes
102	Aldrin	µg/L	0.00013	<0.00028	No

CTR No.	Pollutant	Unit	C or Governing Criterion or Objective (µg/L)	MEC or Minimum DL (µg/L) ^{[1],[2]}	RPA Result ^[3]
103	Alpha-BHC	µg/L	0.0039	0.00031	No
104	Beta-BHC	µg/L	0.014	0.00069	No
105	Gamma-BHC	µg/L	0.019	0.00045	No
106	Delta-BHC	µg/L	No Criteria	<0.00014	U
107	Chlordane	µg/L	0.00057	<0.0023	U
108	4,4'-DDT	µg/L	0.00059	0.00017	No
109	4,4'-DDE	µg/L	0.00059	0.00018	No
110	4,4'-DDD	µg/L	0.00083	0.00011	No
111	Dieldrin	µg/L	0.00014	<0.00014	U
112	Alpha-Endosulfan	µg/L	0.0087	0.00046	No
113	beta-Endosulfan	µg/L	0.0087	0.00011	No
114	Endosulfan Sulfate	µg/L	110	0.00033	No
115	Endrin	µg/L	0.0023	0.00018	No
116	Endrin Aldehyde	µg/L	0.76	0.00053	No
117	Heptachlor	µg/L	0.00021	<0.00041	U
118	Heptachlor Epoxide	µg/L	0.00010	<0.00025	U
119-125	PCBs sum	µg/L	0.00017	<0.017	U
126	Toxaphene	µg/L	0.00020	<0.002	U
	Cis-1,2-Dichloroethylene	µg/L	6.0	3.5	No
	Xylenes	µg/L	1,750	78	No
	Methyl-tertiary-butyl ether	µg/L	5.0	33	Yes

Footnotes:

- ^[1] The MEC and ambient background concentration are the actual detected concentrations unless preceded by a "<" sign, in which case the value shown is the minimum detection level (MDL).
- ^[2] The MEC or ambient background concentration is "Unavailable" when there are no monitoring data for the constituent.
- ^[3] RPA Results = Yes, if MEC ≥ WQC, B > WQC and MEC is detected, or Trigger 3
= No, if MEC and B are < WQC or all effluent data are undetected
= Unknown (U) if no criteria have been promulgated or data are insufficient.
- ^[4] Reasonable potential analysis is based on Trigger 3 considering U.S. EPA's freshwater selenium criterion whole-body fish tissue element of 8.5 mg/kg by dry weight. Reasonable potential was found for discharges to Stevens Creek in Santa Clara County only.
- ^[5] On April 13, 2022, Meta (formerly known as Facebook) reported a selenium effluent concentration of 460 µg/L. This datum was not considered in this analysis because it is not representative of the discharges covered by this Order. This effluent limit violation was subject to ACL Order R2-2023-1002 issued by the Regional Water Board on June 1, 2023.
- ^[6] Bis(2-ethylhexyl)phthalate is a common laboratory contaminant and is not anticipated to be a pollutant of concern for the types of discharges this Order allows. This Order requires sampling for bis(2-ethylhexyl)phthalate to be performed using ultra clean sampling techniques for re-evaluation during future permit reissuance.

4.3.3.3.1. Acute and Chronic Toxicity. Dischargers covered by this Order are exempt from toxicity requirements. Toxicity Provisions section III.C.11 exempts insignificant non-stormwater discharges from acute and chronic toxicity requirements if they do not have reasonable potential to cause or contribute to the exceedance of toxicity water quality objectives. In accordance with Toxicity Provisions section III.C.11, reasonable potential analysis does not need to include the analysis methods in Toxicity Provisions section III.C.3. The discharges covered by this Order are

insignificant and do not have reasonable potential to cause or contribute to the exceedance of toxicity water quality objectives. Dischargers covered by this Order often discharge directly to storm drains on a short-term basis. During the previous orders terms, Dischargers conducted toxicity tests in at least 300 instances, and toxicity was not observed in any discharge, except a single instance where high salinity likely caused the toxicity. In that instance, the high salinity did not cause toxicity in the estuarine receiving water. As required by the Toxicity Provisions, discharges covered by this Order may not cause an exceedance of water quality objectives for aquatic toxicity in receiving waters (see section 5 of the Order).

4.3.3.3.2. **Sediment Quality.** Pollutants in some receiving water sediments may be present in quantities that alone or in combination are toxic to benthic communities. The Sediment Quality Plan states that effluent limits to protect sediment quality are to be developed when:

- a direct relationship between the discharge and degraded sediment has been established;
- the pollutants causing degradation have been identified; and
- the reductions in pollutant loading needed to restore sediment quality have been estimated.

However, to date there is no evidence directly linking compromised sediment conditions to the discharges subject to this Order; therefore, the Regional Water Board does not find reasonable potential for these discharges to cause or contribute to exceedances of the sediment quality objectives.

4.3.3.3.3. **Narrative Water Quality Objectives.** Basin Plan chapter 3 includes narrative water quality objectives for all surface waters within the region, except the Pacific Ocean. Where reasonable potential is found, the Basin Plan requires these objectives to be translated into effluent limitations.

4.3.3.3.3.1. Basin Plan section 3.3.1 requires that discharges not exceed bacterial water quality objectives for marine and freshwater receiving waters with water contact recreation, shellfish harvesting, non-contact water recreation, and municipal supply beneficial uses. Discharges covered by this Order are not known to be sources of anthropogenic bacteria. Furthermore, this Order prohibits the discharge of domestic sewage. Therefore, there is no reasonable potential for discharges to exceed

this narrative water quality objective in receiving waters. See section 3.2 of the Order.

- 4.3.3.3.2. Basin Plan section 3.3.2 requires that controllable water quality factors not cause a detrimental increase in the concentration of bioaccumulative, toxic substances in bottom sediments or aquatic life. This Order finds reasonable potential for certain bioaccumulative pollutants (e.g., selenium). As explained in Fact Sheet section 4.3.3.3, elevated levels of selenium in Stevens Creek fish tissue demonstrate that the narrative bioaccumulation water quality objective is not being met. Therefore, this Order contains effluent limitations and monitoring requirements for selenium. Similarly, the Order contains effluent limitations and monitoring requirements for mercury because discharge data shows reasonable potential for this pollutant to exceed its water quality criteria. The effluent limitations for selenium and mercury included in this Order are sufficient to prevent excursions above this narrative water quality objective in receiving waters.
- 4.3.3.3.3. Basin Plan section 3.3.3 requires that receiving waters not contain biostimulatory substances in concentrations that promote aquatic growths to the extent that such growths cause nuisance or adversely affect beneficial uses. Discharges covered by this Order are not known to be sources of biostimulatory substances, such as nitrates, ammonium, and phosphates. Furthermore, as described in section 1.2.4, this Order prohibits discharges of sewage, which would contain nutrients. Therefore, there is no reasonable potential for discharges to contain biostimulatory substances in concentrations that could exceed this narrative water quality objective in receiving waters.
- 4.3.3.3.4. Basin Plan section 3.3.4 requires that discharges be free of coloration that causes nuisance or adversely affects beneficial uses. Discharges covered by this Order are not known to be sources of substances causing coloration at levels adversely affecting beneficial uses or nuisance. Covered discharges receive at least filtration treatment and more advanced treatment, such as GAC, for organic compounds. This treatment is expected to remove substances that may produce coloration. Therefore, there is no reasonable potential for discharges to exceed this narrative water quality objective in receiving waters.
- 4.3.3.3.5. Basin Plan section 3.3.5 requires that dissolved oxygen remain above 5.0 mg/L in tidal waters downstream of Carquinez Bridge and above 7.0 mg/L in tidal waters upstream of Carquinez Bridge. It also requires that dissolved oxygen remain above 7.0 mg/L in nontidal waters with cold water habitat beneficial uses and above 5.0 mg/L in nontidal waters with warm water habitat beneficial uses. Furthermore, the median dissolved oxygen concentration for any three consecutive months is not to be less than 80 percent of the dissolved oxygen

content at saturation. When natural factors cause concentrations less than that specified above, the discharge is not to cause further reduction in ambient dissolved oxygen concentrations.

Discharges covered by this Order are likely to contain relatively low dissolved oxygen concentrations because groundwater exists in anaerobic environments. However, discharges receive at least filtration treatment and more advanced treatment that incidentally aerates the wastewater. Furthermore, most covered discharges are directed to storm drains where additional aeration occurs. Therefore, there is no reasonable potential for discharges to contain dissolved oxygen at levels below the narrative water quality objective.

- 4.3.3.3.3.6. Basin Plan section 3.3.6 requires that discharges not contain floating material, including solids, liquids, foams, and scum, in concentrations that cause nuisance or adversely affect beneficial uses. The discharges covered by this Order receive at least filtration treatment and more advanced treatment for organic compounds that also remove floating solids, liquids, foams, and scum. Furthermore, as described in Discharge Prohibition 3.3, this Order prohibits discharges of floating oil, residual petroleum products, or other floating materials. Therefore, there is no reasonable potential for discharges to exceed this narrative water quality objective in receiving waters.
- 4.3.3.3.3.7. Basin Plan section 3.3.7 requires that discharges not contain visible, floating, suspended, or deposited oil or other products of petroleum origin. The discharges covered by this Order receive at least filtration treatment and more advanced treatment, such as GAC, for compounds of petroleum origin to meet technology-based effluent limitations for VOCs and petroleum-related compounds (e.g., TPH as gasoline, TPH as diesel, and TPH as motor oil). Furthermore, as described in Discharge Prohibition 3.3, this Order prohibits discharges of floating oil, residual petroleum products, or other floating materials. Therefore, there is no reasonable potential for discharges to exceed this narrative water quality objective in receiving waters. See Fact Sheet section 4.2.2.
- 4.3.3.3.3.8. Basin Plan section 3.3.8 requires that receiving waters remain free of toxic substances in concentrations that are lethal to or that produce significant alterations in population or community ecology or receiving water biota. As described in Fact Sheet section 4.3.3.3.1, discharges covered by this Order are not known to be sources of toxicity. Therefore, there is no reasonable potential for discharges to exceed this narrative water quality objective in receiving waters.
- 4.3.3.3.3.9. Basin Plan section 3.3.9 requires that pH not be depressed below 6.5 nor raised above 8.5 in receiving waters, and that discharges not cause

changes greater than 0.5 pH units in normal ambient pH levels. The technology-based effluent limitations for pH are sufficient to prevent excursions outside this narrative water quality objective. Therefore, there is no reasonable potential for discharges to violate the narrative water quality objective in receiving waters. See Fact Sheet section 4.2.2.1.

- 4.3.3.3.10. Basin Plan section 3.3.10 requires that radioactive material not be present in concentrations that result in the accumulation of radionuclides in the food web that could present hazards to human, plant, animal, or aquatic life. Discharges covered by this Order are not known to be sources of radioactive substances that would present hazards to human, plant, animal, or aquatic life. Therefore, there is no reasonable potential for discharges to contain radionuclides at levels above this narrative water quality objective.
- 4.3.3.3.11. Basin Plan section 3.3.11 requires that discharges not increase the total dissolved solids or salinity of receiving waters so as to adversely affect beneficial uses. Discharges covered by this Order are rarely sources of salinity that would adversely affect beneficial uses of receiving waters. However, locations near former salt evaporation ponds in the southern portion of the San Francisco Bay Region may have higher levels of salinity in groundwater compared to surface waters. Therefore, this Order establishes effluent and receiving water monitoring requirements for salinity to assess whether discharges exceed this narrative water quality objective in receiving waters. See Attachment E section 3.1 and 3.2.
- 4.3.3.3.12. Basin Plan section 3.3.12 requires that discharges not alter suspended sediment in such a manner as to cause nuisance or adversely affect beneficial uses or detrimental increase in the concentrations of toxic pollutants in sediments or aquatic life. Discharges covered by this Order receive at least filtration treatment and more advanced treatment for dissolved compounds that also remove suspended sediment. Therefore, there is no reasonable potential for discharges to exceed this narrative water quality objective in receiving waters.
- 4.3.3.3.13. Basin Plan section 3.3.13 requires that discharges not cause bottom deposits or aquatic growths to the extent that such deposits or growths cause nuisance or adversely affect beneficial uses. The discharges covered by this Order receive at least filtration treatment and more advanced treatment for dissolved compounds. Furthermore, covered discharges are not known to be sources of substances, such as nitrates, ammonium, and phosphates, that may cause aquatic growths to the extent that such growths could cause a nuisance or affect beneficial uses. Therefore, there is no reasonable potential for

discharges to exceed this narrative water quality objective in receiving waters.

- 4.3.3.3.3.14. Basin Plan section 3.3.14 requires that discharges not contain suspended material in concentrations that cause nuisance or adversely affect beneficial uses. Discharges covered by this Order receive at least filtration treatment and more advanced treatment for dissolved compounds that also remove suspended materials. Therefore, there is no reasonable potential for discharges to exceed this narrative objective in receiving waters.
- 4.3.3.3.3.15. Basin Plan section 3.3.15 requires that discharges be free of dissolved sulfides above natural background levels. Sulfides can occur as a result of bacterial activity on organic matter under anaerobic conditions. Sulfides cannot exist to a significant degree in an oxygenated environment. The discharges covered by this Order are likely to contain sulfide concentrations because groundwater exists in anaerobic environments. However, these discharges also receive at least filtration treatment and more advanced treatment that incidentally aerate treated groundwater. Additionally, most covered discharges are directed to storm drains where additional aeration occurs. Therefore, there is no reasonable potential for discharges to contain sulfides at levels above this narrative water quality objective.
- 4.3.3.3.3.16. Basin Plan section 3.3.16 requires that discharges not contain taste- or odor-producing substances that impart undesirable tastes or odors to edible products of aquatic origin, that cause nuisance, or that adversely affect beneficial uses. Discharges covered by this Order are not known to contain anthropogenic substances that impart undesirable tastes or odors to edible products of aquatic origin, that cause nuisance, or that adversely affect beneficial uses in receiving waters. Covered discharges receive at least filtration treatment and more advanced treatment, such as GAC, for organic compounds that also remove substances that may impart undesirable tastes and odors. Therefore, there is no reasonable potential for discharges to exceed this narrative water quality objective in receiving waters.
- 4.3.3.3.3.17. Basin Plan section 3.3.17 requires that discharges not alter temperatures beyond present natural background levels unless it can be demonstrated that such alterations do not adversely affect beneficial uses, and prohibits temperature increases of more than 2.8°C above natural receiving water temperatures. Discharges covered by this Order receive at least filtration and adsorption treatment, neither of which involves thermal inputs. Therefore, there is no reasonable potential for

discharges to exceed this narrative water quality objective in receiving waters.

- 4.3.3.3.18. Basin Plan section 3.3.18 requires that discharges be free of toxic substances in concentrations that are lethal to or that produce detrimental responses to aquatic organism. As described in Fact Sheet section 4.3.3.3.1, discharges covered by this Order are not known to be sources of toxicity. Therefore, there is no reasonable potential for discharges to exceed this narrative water quality objective in receiving waters.
- 4.3.3.3.19. Basin Plan section 3.3.19 requires that discharges be free of changes in turbidity that cause nuisance or adversely affect beneficial uses, or increases from normal background light penetration or turbidity greater than 10 percent in areas where natural turbidity is greater than 50 nephelometric turbidity units. Discharges covered by this Order receive at least filtration and more advanced treatment that also removes turbidity in treated groundwater. Therefore, there is no reasonable potential for discharges to exceed this narrative water quality objective in receiving waters.
- 4.3.3.3.20. Basin Plan section 3.3.20 requires that discharges be free of un-ionized ammonia to prevent annual median concentrations in excess of 0.025 mg/L (as nitrogen) and concentrations in Central and Lower San Francisco Bay in excess 0.16 mg/L and 0.4 mg/L (as nitrogen). Discharges covered by this Order are not known to be sources of un-ionized ammonia in concentrations that are toxic to receiving waters. Furthermore, this Order prohibits the discharge of domestic sewage, which can contain ammonia. Therefore, there is no reasonable potential for discharges to exceed this narrative water quality objective in receiving waters. See section 3.2 of the Order.

4.3.4. **Water Quality-Based Effluent Limitations**

WQBELs were developed for the pollutants determined to have reasonable potential to cause or contribute to exceedances of water quality objectives. The WQBELs calculations are based on the procedures in SIP section 1.4, which is used as guidance for other pollutants. The tables below list the WQBELs.

Table F-9. WQBELs Summary – Class 1-3 Discharges

Pollutant	Unit	CTR-Human Health				CTR-Aquatic Life		MCLs	
		Discharges to Receiving Waters Used as Drinking Water		Discharges to Other Receiving Waters		Discharges to All Receiving Waters		Discharges to Receiving Waters Used as Drinking Water	
		AMEL	MDEL	AMEL	MDEL	AMEL	MDEL	AMEL	MDEL
Cadmium, Total Recoverable	µg/L	-	-	-	-	0.90	1.8	5.0	10
Copper, Total Recoverable									
<i>South SF Bay</i>	µg/L	1,300	2,600	-	-	10	20	1,300	2,600
<i>Central or Lower SF Bay</i>	µg/L	1,300	2,600	-	-	5.4	11	1,300	2,600
<i>Suisun or San Pablo Bay</i>	µg/L	1,300	2,600	-	-	7.1	14	1,300	2,600
<i>Freshwater</i>	µg/L	1,300	2,600	-	-	7.0	14	1,300	2,600
Lead, Total Recoverable	µg/L	-	-	-	-	2.6	5.2	15	30
Nickel, Total Recoverable									
<i>South SF Bay</i>	µg/L	610	1,200	4,600	9,200	22	44	100	200
<i>Central or Lower SF Bay</i>	µg/L	610	1,200	4,600	9,200	10	21	100	200
<i>Suisun or San Pablo Bay</i>	µg/L	610	1,200	4,600	9,200	25	50	100	200
<i>Freshwater</i>	µg/L	610	1,200	4,600	9,200	43	86	100	200
Selenium, Total Recoverable	µg/L	-	-	-	-	2.5	5.1	50	100

Table F-10. WQBELs Summary – Class 4 Discharges

Pollutant	Unit	CTR-Human Health				CTR-Aquatic Life		MCLs	
		Discharges to Receiving Waters Used as Drinking Water		Discharges to Other Receiving Waters		Discharges to All Receiving Waters		Discharges to Receiving Waters Used as Drinking Water	
		AMEL	MDEL	AMEL	MDEL	AMEL	MDEL	AMEL	MDEL
Antimony, Total Recoverable	µg/L	14	28	4,300	8,600	-	-	6.0	12
Arsenic, Total Recoverable	µg/L	-	-	-	-	30.	59	10.	20
Cadmium, Total Recoverable	µg/L	-	-	-	-	0.90	1.8	5.0	10
Chromium VI	µg/L	-	-	-	-	8.1	16	10	20
Copper, Total Recoverable									
<i>South SF Bay</i>	µg/L	1,300	2,600	-	-	10	20	1,300	2,600
<i>Central or Lower SF Bay</i>	µg/L	1,300	2,600	-	-	5.4	11	1,300	2,600
<i>Suisun or San Pablo Bay</i>	µg/L	1,300	2,600	-	-	7.1	14	1,300	2,600

Pollutant	Unit	CTR-Human Health				CTR-Aquatic Life		MCLs	
		Discharges to Receiving Waters Used as Drinking Water		Discharges to Other Receiving Waters		Discharges to All Receiving Waters		Discharges to Receiving Waters Used as Drinking Water	
		AMEL	MDEL	AMEL	MDEL	AMEL	MDEL	AMEL	MDEL
<i>Freshwater</i>	µg/L	1,300	2,600	-	-	7.0	14	1,300	2,600
Lead, Total Recoverable	µg/L	-	-	-	-	2.6	5.2	15	30
Mercury	µg/L	0.05	0.10	0.05	0.10	-	-	2.0	4.0
Nickel, Total Recoverable									
<i>South SF Bay</i>	µg/L	610	1,200	4,600	9,200	22	44	100	200
<i>Central or Lower SF Bay</i>	µg/L	610	1,200	4,600	9,200	10	21	100	200
<i>Suisun or San Pablo Bay</i>	µg/L	610	1,200	4,600	9,200	25	50	100	200
<i>Freshwater</i>	µg/L	610	1,200	4,600	9,200	43	86	100	200
Selenium, Total Recoverable	µg/L	-	-	-	-	2.5	5.1	50	100
Silver, Total Recoverable	µg/L	-	-	-	-	1.1	2.2	-	-
Thallium, Total Recoverable	µg/L	1.7	3.4	6.3	13	-	-	2.0	4.0
Zinc, Total Recoverable	µg/L					47	95		
Cyanide	µg/L	700	1,400	220,000	440,000	2.4	4.8	150	300
Dichlorobromomethane	µg/L	0.56	1.1	46	92	-	-	-	-
1,2-Dichloroethane	µg/L	0.38	0.76	99	200	-	-	0.50	1.0
Methylene Chloride	µg/L	4.7	9.4	1,600	3,200	-	-	5.0	10
Tetrachloroethylene	µg/L	0.8	1.6	8.9	18	-	-	5.0	10
Trichloroethylene	µg/L	2.7	5.4	81	160	-	-	5.0	10
Vinyl Chloride	µg/L	2.0	4.0	530	1,100	-	-	0.50	1.0
2,4-Dichlorophenol	µg/L	93	190	790	1,600	-	-	-	-
2,4,6-Trichlorophenol	µg/L	2.1	4.2	6.5	13	-	-	-	-
Benzidine	µg/L	0.00012	0.00024	0.00054	0.0011	-	-	-	-
Bis(2-Chloroethyl) Ether	µg/L	0.031	0.062	1.4	2.8	-	-	-	-
Chrysene	µg/L	0.0044	0.0088	0.049	0.098	-	-	-	-
3,3-Dichlorobenzidine	µg/L	0.04	0.08	0.077	0.15	-	-	-	-
2,4-Dinitrotoluene	µg/L	0.11	0.22	9.1	18	-	-	-	-
1,2-Diphenylhydrazine	µg/L	0.040	0.080	0.54	1.1	-	-	-	-
Hexachlorobenzene	µg/L	0.00075	0.0015	0.00077	0.0015	-	-	1.0	2.0
1,2,4-Trichlorobenzene	µg/L	-	-	-	-	-	-	5.0	10
Cis-1,2-Dichloroethylene	µg/L	-	-	-	-	-	-	6.0	12
Xylenes	µg/L	-	-	-	-	-	-	1,750	3,500
Methyl tertiary-butyl ether	µg/L	-	-	-	-	-	-	13	26

4.3.4.2. **WQBELs Based on Human Health.** WQBELs for pollutants that demonstrate reasonable potential based on CTR human health criteria are calculated in accordance with SIP section 1.4. The average monthly effluent limitations (AMELs) are set equal to the criteria. The maximum daily effluent limitations (MDELs) are calculated by multiplying the AMEL by an MDEL/AMEL multiplier of 2.01, which is derived from a default effluent data coefficient of variation of 0.6.

- 4.3.4.3. **WQBELs Based on Aquatic Life Criteria.** WQBELs for pollutants that demonstrate reasonable potential based on Basin Plan and CTR aquatic life criteria are calculated in accordance with SIP section 1.4. The AMELs are set equal to the criteria. The MDELs are calculated by multiplying the AMEL by an MDEL/AMEL multiplier of 2.01, which is derived from a default effluent data coefficient of variation of 0.6.
- 4.3.4.4. **WQBELs Based on MCLs.** WQBELs for pollutants that demonstrate reasonable potential based on MCLs listed in the California Code of Regulations, title 22, sections 64431, 64444, and 64449, are calculated using SIP section 1.4 as guidance. These limits apply to discharges to waters with the “Municipal and Domestic Supply” or “Groundwater Recharge” beneficial use designations. The AMELs are set equal to the MCLs. The MDELs are calculated by multiplying the AMEL by an MDEL/AMEL multiplier of 2.01, which is derived from a default effluent data coefficient of variation of 0.6.

4.4. Discharge Requirement Considerations

- 4.4.1. **Anti-Backsliding.** This Order complies with the anti-backsliding provisions of CWA sections 402(o) and 303(d)(4), and 40 C.F.R. section 122.44(l), which generally require effluent limitations in a reissued permit to be as stringent as those in the previous order. The requirements of this Order are at least as stringent as those in the previous orders.

For Class 1 and Class 2 discharges, this Order does not retain WQBELs for chloride, selenium (except for discharges to Stevens Creek in Santa Clara County), total dissolved solids, and turbidity because data no longer indicate reasonable potential to cause or contribute to exceedances of water quality objectives.

For Class 4 discharges, this Order does not retain WQBELs for acute toxicity, chromium III, benzo(a)anthracene, benzo(a)pyrene, benzo(b)fluoranthene, benzo(k)fluoranthene, dibenz(a,h)anthracene, indeno(1,2,3-cd)pyrene, selenium (except for discharges to Stevens Creek in Santa Clara County), and turbidity because data no longer indicate reasonable potential to cause or contribute to exceedances of water quality objectives.

The removal of these limitations is consistent with State Water Board Order WQ 2001-16, in which the State Water Board held that anti-backsliding does not necessarily dictate that a pollutant that was limited in a prior permit must have a limit in a later permit, even though there is no reasonable potential that the pollutant discharge will cause or contribute to a water quality standard exceedance. The State Water Board stated that where the anti-backsliding exception in CWA section 303(d)(4)(B) is met (see section 4.4.2 below), the limit may be removed. The removal of these effluent limitations is consistent with antidegradation policies as explained below.

As discussed in Fact Sheet sections 5 and 6.4, this Order removes the generalized receiving water limitations that were included in the previous orders. This Order also removes two discharge prohibitions that were included in the previous orders (Discharge Prohibitions III.B and III.D of Order R2-2017-0048, and Discharge Prohibitions III.C and III.H of Order R2-2018-0026). One discharge prohibition prohibited discharge of silt, sand, clay, or other earthen materials in a manner that would affect or threaten to affect beneficial uses in receiving waters. The other discharge prohibition prohibited discharges to storm drains that cause scouring, erosion, excessive sedimentation, or flooding of the storm drain system or receiving water downstream of the point of discharge. This Order also removes part of the nuisance provision contained in the previous orders (Discharge Prohibition III.E of Order R2-2017-0048 and III.G of R2-2018-0026), retaining the remainder as a State-only requirement (see Fact Sheet section 6.4). The removal of these requirements, as a matter of federal law, is consistent with the U.S. Supreme Court's holding in *City and County of San Francisco, California v. Environmental Protection Agency* (2025) 145 S.Ct. 704. However, as discussed in Fact Sheet section 4.3.4.4.5, the Regional Water Board has determined that the requirements in this Order are sufficient to ensure the discharge complies with Clean Water Act section 301(b)(1)(C) (33 U.S.C. § 1311(b)(1)(C)). As a result, the removal of the receiving water limitations and the discharge prohibitions does not authorize the additional discharge of pollutants or authorize the violation of water quality standards. This Order does not, therefore, authorize either backsliding or further degradation of water quality.

- 4.4.2. **Antidegradation.** This Order complies with the antidegradation provisions of 40 C.F.R. section 131.12 and State Water Board Resolution 68-16. It does not authorize lowering water quality as compared to the level of discharge authorized in the previous order, which is the baseline by which to measure whether degradation will occur. This Order does not allow for an increased flow, a reduced level of treatment, or increased effluent limitations relative to the previous orders.

This Order does not retain WQBELs for acute toxicity, chloride, total dissolved solids, turbidity, chromium III, selenium (except for discharges to Stevens Creek in Santa Clara County), benzo(a)anthracene, benzo(a)pyrene, benzo(b)fluoranthene, benzo(k)fluoranthene, dibenz(a,h)anthracene, and indeno(1,2,3-cd)pyrene from the previous order because data no longer indicate reasonable potential for these pollutants to exceed water quality objectives. The quantities of these pollutants are not expected to exceed the quantity discharged under the previous order when the effluent limitations were in place because these WQBELs did not drive treatment performance. Treatment performance is maintained by the remaining effluent limitations imposed by this Order. Furthermore, the effluent limitations for chloride, total dissolved solids, and turbidity were based on secondary Maximum Contaminant Levels that protected aesthetic characteristics rather than aquatic life or human health, such as taste and odor, for receiving waters with "Municipal and

Domestic Supply” or “Groundwater Recharge” beneficial uses. Discharge Prohibition 3.3 and turbidity monitoring requirements in Attachment E (MRP) will maintain controls on turbidity to protect beneficial uses.

This Order removes the generalized receiving water limitations and two discharge prohibitions that were included in the previous orders (Discharge Prohibitions III.B and III.D. of Order R2-2017-0048, and Discharge Prohibitions III.C and III.H of Order R2-2018-0026). One discharge prohibition prohibited discharge of silt, sand, clay, or other earthen materials in a manner that would affect or threaten to affect beneficial uses in receiving waters. The other discharge prohibition prohibited discharges to storm drains that cause scouring, erosion, excessive sedimentation, or flooding of the storm drain system or receiving water downstream of the point of discharge. As discussed in Fact Sheet section 4.3.3.3.3, the effluent limits established in this Order are sufficient to protect receiving waters. The removal of the generalized receiving water limitations and discharge prohibitions will not result in an increased volume or concentration of pollutants in the discharge. As explained in Fact Sheet section 4.3.3.3.3, the technology and water quality-based effluent limits established in this Order are sufficient to drive treatment system performance in a manner comparable to the previous orders and to ensure that water quality and beneficial uses are protected. Additionally, this Order includes receiving water limits related to toxicity pursuant to State law only (see Fact Sheet section 5). This Order does not, therefore, authorize further degradation of water quality.

- 4.4.3. **Stringency of Requirements for Individual Pollutants.** This Order contains both technology-based and water quality-based effluent limitations for individual pollutants. The technology-based requirements implement minimum, applicable federal technology-based requirements. In addition, this Order contains more stringent effluent limitations as necessary to meet water quality standards. Collectively, this Order’s restrictions on individual pollutants are no more stringent than required to implement CWA requirements.

This Order’s WQBELs have been derived to implement water quality objectives that protect beneficial uses. The beneficial uses and water quality objectives have been approved pursuant to federal law and are the applicable federal water quality standards. To the extent that WQBELs were derived from the CTR, the CTR is the applicable standard pursuant to 40 C.F.R. section 131.38. The procedures for calculating these WQBELs are based on the CTR, as implemented in accordance with the SIP, which U.S. EPA approved on May 18, 2000. U.S. EPA approved most Basin Plan beneficial uses and water quality objectives prior to May 30, 2000. Beneficial uses and water quality objectives submitted to U.S. EPA prior to May 30, 2000, but not approved by U.S. EPA before that date, are nonetheless “applicable water quality standards for purposes of the CWA” pursuant to 40 C.F.R. section 131.21(c)(1). U.S. EPA approved the remaining beneficial uses and water quality objectives, so they

are also applicable water quality standards pursuant to 40 C.F.R. section 131.21(c)(2).

5. RATIONALE FOR RECEIVING WATER LIMITATIONS

This Order removes the generalized receiving water limitations contained in section V of the previous orders. Those limitations served as backstops for unanticipated circumstances or changes to effluent quality that could affect water quality. The receiving water limitations made the Discharger responsible for the quality of the receiving water without specifying specific requirements (e.g., effluent limitations) or other actions the Discharger must take that apply at or before the discharge point. The Regional Water Board removed the receiving water limitations to be consistent with the U.S. Supreme Court's ruling in *City and County of San Francisco, California v. Environmental Protection Agency* (2025) 145 S.Ct. 704, which held that NPDES permits issued by the U.S. EPA may not include end-result requirements under the Clean Water Act. End-result requirements are provisions that do not spell out what the Discharger must do or refrain from doing; rather, they make the Discharger responsible for the quality of the water in the body of water into which it discharges pollutants.²

Section 5 of the Order includes receiving water limitations for aquatic toxicity objectives under State law only. The Toxicity Provisions require the Regional Water Board to include receiving water limitations for the aquatic toxicity objectives when applying the exemption for insignificant discharges. As described in Fact Sheet section 4.3.3.3.1, the discharges covered by this Order are insignificant discharges as defined in the Toxicity Provisions. The inclusion of the receiving water limitations as State-only requirements is consistent with *City and County of San Francisco v. U.S. EPA* and *Camarillo Sanitary District v. State Water Resources Control Board* as both cases addressed requirements in NPDES permits relying on federal authority.

The requirements in this Order will ensure that the discharge satisfies Clean Water Act section 301(b)(1)(C) (33 U.S.C. § 1311(b)(1)(C)), which requires that the permit include any more stringent limitation, including those necessary to meet water quality standards. See Fact Sheet section 4.3.3.3.3. If unanticipated circumstances or changes to effluent quality occur during the permit term, the Regional Water Board may reopen the permit to include any limitations necessary to protect water quality.

² While the Regional Water Board removed generalized receiving water limitations in accordance with the U.S. Supreme Court's decision interpreting the Clean Water Act's NPDES requirements, the Regional Water Board may decide in the future to include similar requirements as a matter of State authority.

6. RATIONALE FOR PROVISIONS

6.1. Standard Provisions

Attachment D contains standard provisions that apply to all NPDES permits in accordance with 40 C.F.R. section 122.41 and additional conditions applicable to specific categories of permits in accordance with 40 C.F.R. section 122.42. The Discharger must comply with these provisions. The conditions set forth in 40 C.F.R. sections 122.41(a)(1) and (b) through (n) apply to all state-issued NPDES permits and must be incorporated into permits either expressly or by reference.

In accordance with 40 C.F.R. section 123.25(a)(12), states may omit or modify conditions to impose more stringent requirements. This Order also omits the federal conditions that address enforcement authority specified in 40 C.F.R. sections 122.41(j)(5) and (k)(2) because the State's enforcement authority under the Water Code is more stringent. In lieu of these conditions, this Order incorporates Water Code section 13387(e) by reference.

6.2. Monitoring and Reporting Provisions

CWA section 308 and 40 C.F.R. sections 122.41(h), 122.41(j)-(l), 122.44(i), and 122.48 require that NPDES permits specify monitoring and reporting requirements. Water Code section 13383 also authorizes the Regional Water Board to establish monitoring, inspection, entry, reporting, and recordkeeping requirements. The MRP establishes monitoring, reporting, and recordkeeping requirements that implement federal and State requirements. For more information, see Fact Sheet section 7.

6.3. Special Provisions

6.3.1. Reopener Provisions

These provisions are based on 40 C.F.R. sections 122.62 and 122.63 and allow modification of this Order and its effluent limitations as necessary in response to updated water quality objectives, regulations, or other new and relevant information that may become available in the future, and other circumstances as allowed by law.

6.3.2. Application for General Permit Coverage and Authorization to Discharge

These provisions require submittal of an NOI form and compliance with this Order upon receipt of an Authorization to Discharge, and are based on 40 C.F.R. section 122.28(b). They allow the Executive Officer to terminate an Authorization to Discharge based on 40 C.F.R. section 122.28(b). The provision allowing the Executive Officer to require an individual permit is based on 40 C.F.R. section 122.28(b)(3).

6.3.3. Contingency Plan

The requirement to develop a Contingency Plan to ensure proper facility operation in the event of an emergency is based on Regional Water Board Resolution 74-10. Discharge in violation of this Order where the Discharger has failed to develop and implement a Contingency Plan as the Order requires could be the basis for considering the discharge a willful and negligent violation of the Order pursuant to Water Code section 13387.

6.3.4 Spill Prevention Plan

The requirement to develop a Spill Prevention Plan to prevent accidental discharges and minimize the effects of any such discharges is based on 40 C.F.R. section 112 and best professional judgment. Discharge in violation of this Order where the Discharger has failed to develop and implement a Spill Prevention Plan as the Order requires could be the basis for considering the discharge a willful and negligent violation of the Order pursuant to Water Code section 13387.

6.3.5. Operation and Maintenance Manual

The requirement to develop an Operation and Maintenance Manual to ensure that operations and maintenance procedures are in place that are useful and relevant to current equipment and operational practices is based on 40 C.F.R. section 122.41(e) and best professional judgment.

6.3.6. Water Reclamation

Consistent with Regional Water Board Resolution No. 88-160, treated groundwater reclamation is a preferred method of disposal. The water reclamation specifications are retained from the previous order to protect public health.

6.3.7. No Preemption

This provision clarifies that this Order does not preempt or supersede the authority of municipalities, flood control agencies, or other agencies to prohibit, restrict, or control discharges to storm drain systems or other watercourses subject to their jurisdiction.

6.4. Discharge Prohibition and Receiving Water Limitations from Previous Orders Retained to Implement State Law Only

Discharge Prohibitions III.E of Order R2-2017-0048 and III.G of R2-2018-0026 (the previous orders) stated, "Wastewater collection, treatment, or discharge of pollutants that causes pollution, contamination, or nuisance as defined by Water Code section 13050 is prohibited." Consistent with the holding in *City and County of San Francisco, California v. Environmental Protection Agency* (2025) 145 S.Ct.

704 (discussed in Fact Sheet section 4.3.4.4.5), this Order does not retain this prohibition as a federal requirement. However, this Order does retain a modified version of this prohibition in section 3.5 as a matter of State law: “the treatment of pollutants shall not create nuisance as defined by California Water Code section 13050.” This requirement does not address the discharge of pollutants or pollution or contamination because this Order includes technology-based and water quality-based effluent limitations sufficient to prevent nuisance or contamination in receiving waters associated with discharges covered by this Order.

The Regional Water Board has maintained this prohibition as a State law requirement to implement Water Code section 13263, which identifies the need to prevent nuisance as a factor to consider when issuing waste discharge requirements. The U.S. Supreme Court’s decision in *City and County of San Francisco v. U.S. EPA* did not interpret the Water Code. Furthermore, there is no provision of the Water Code analogous to the NPDES permit shield that was a part of the basis of the U.S. Supreme Court’s decision. Likewise, the Porter-Cologne Water Quality Control Act has consistently recognized the ability of the Water Boards to regulate to prevent nuisance, and the Porter-Cologne Water Quality Control Act does not share the legislative history of the federal Clean Water Act. This Order, therefore, maintains the prohibition identified above to continue its protections as a matter of State law.

Section V of the previous orders contained receiving water limitations related to discharges containing toxicity. Specifically, section V.9 prohibited the discharge of “Toxic or other deleterious substances in concentrations or quantities that cause deleterious effects on...aquatic biota...either at levels created in the receiving waters or as a result of biological concentration.” Section V.C stated, “Discharge shall not cause a violation of any water quality standard for receiving waters adopted by the Regional Water Board or State Water Resources Control Board (State Water Board) as required by the CWA and regulations adopted thereunder,” which now includes the objectives in the Toxicity Provisions. Consistent with *City and County of San Francisco, California v. Environmental Protection Agency* and *Camarillo Sanitary District v. State Water Resources Control Board*, this Order does not retain these receiving water limitations as federal requirements. This Order does, however, include receiving water limitations for aquatic toxicity in section 5 as a matter of State law only.

The Regional Water Board included the receiving water limitations as State-only requirements to implement the Toxicity Provisions. The Toxicity Provisions require the Regional Water Board to include receiving water limitations for aquatic toxicity objectives when applying the exemption for insignificant discharges. As described in Fact Sheet section 4.3.3.3.1, the discharges covered by this Order are insignificant discharges as defined in the Toxicity Provisions.

As required by Water Code section 13263, the Regional Water Board has considered the beneficial uses to be protected, the water quality objectives reasonably required for that purpose, other waste discharges, the need to prevent

nuisance, and the factors listed in Water Code section 13241 in establishing these State law requirements. The Water Code section 13241 factors are considered below.

- 6.4.1. **Past, present, and probable future beneficial uses of water.** Basin Plan Chapter 2 identifies designated beneficial uses for water bodies in the San Francisco Bay Region. Beneficial uses of water relevant to this Order are also identified above in Fact Sheet section 3.3.1. The Regional Water Board has taken beneficial uses into account in establishing the requirements of this Order. Neither the prohibition against nuisance nor the receiving water limitations in section 5 of this Order will adversely affect present and future beneficial uses of water.
- 6.4.2. **Environmental characteristics of the hydrographic unit under consideration, including the quality of water available thereto.** The environmental characteristics of freshwater and non-freshwater receiving waters in the San Francisco Bay Region are described in Basin Plan Table 2-1. Neither the prohibition against nuisance nor the receiving water limitations in section 5 of this Order will adversely affect the environmental characteristics of these receiving waters.
- 6.4.3. **Water quality conditions that could reasonably be achieved through the coordinated control of all factors which affect water quality in the area.** By complying with the CWA-mandated requirements established through this Order, the Dischargers will ensure control over factors that could affect water quality. The requirement to prevent nuisance and the receiving water limitations in section 5 of this Order will ensure that the treatment processes do not result in environmental conditions that could adversely affect the surrounding community.
- 6.4.4. **Economic considerations.** The Dischargers have reliably operated their treatment systems, some over several permit terms, without creating nuisance conditions or exceeding the receiving water limitations in section 5 of this Order. Therefore, this prohibition and the receiving water limitations are unlikely to impose additional economic costs on Dischargers. In the unlikely event that the Dischargers incur additional costs to prevent nuisance or the exceedance of the receiving water limitations in relation to their treatment systems, the costs would be justified and necessary to properly operate and maintain the treatment systems and protect public health and the environment. If a nuisance or an exceedance of the receiving water limitations were to occur, it would have a negative economic impact on tourism, recreation, and affected residents in the area.
- 6.4.5. **The need for developing housing within the region.** Neither the requirement to prevent nuisance nor the receiving water limitations in section 5 of this Order will adversely affect the development of housing within the region.

- 6.4.6. **The need to develop and use recycled water.** Neither the requirement to prevent nuisance nor the receiving water limitations in section 5 of this Order will have an impact on the development and use of recycled water.

7. RATIONALE FOR MONITORING AND REPORTING REQUIREMENTS

CWA section 308 and 40 C.F.R. sections 122.41(h), 122.41(j)-(l), 122.44(i), and 122.48 require that NPDES permits specify monitoring and reporting requirements. Water Code section 13383 also authorizes the Regional Water Board to establish monitoring, inspection, entry, reporting, and recordkeeping requirements. The MRP (Attachment E) establishes monitoring, reporting, and recordkeeping requirements that implement federal and State requirements. The following provides the rationale for the MRP requirements:

- 7.1. Influent Monitoring.** Influent monitoring is necessary to characterize influent wastewater, inform treatment design, assess treatment performance, and inform permit reissuance.
- 7.2. Effluent Monitoring.** Effluent monitoring is necessary to understand facility operations, evaluate compliance with this Order's effluent limitations and prohibitions, and conduct future reasonable potential analyses.
- 7.3. Receiving Water Monitoring.** Receiving water monitoring is necessary to evaluate compliance with this Order's receiving water limitations, evaluate possible impacts to beneficial uses, and characterize the receiving water for future reasonable potential analyses and effluent limitation derivation.
- 7.4. PFAS Monitoring.** Influent and effluent PFAS monitoring is necessary to evaluate treatment performance and compliance with this Order's effluent limitations. This monitoring is also necessary to inform the potential development, or revision, of this permit's technology-based effluent limitations. Midstream monitoring is necessary to identify and address oversaturation and breakthrough in treatment systems using adsorption technologies. Total organic carbon monitoring is necessary to complement assessments of PFAS adsorptive media oversaturation.
- 7.5. PFAS Monitoring Summary Report.** PFAS monitoring summary reports are required from Dischargers treating PFAS to inform the potential development, or revision, of this permit's technology-based effluent limitations.
- 7.6. PFAS Treatment Evaluation Report.** PFAS treatment evaluation reports are required to investigate adsorptive media oversaturation that may not be corrected by replacing adsorptive media. They are necessary to ensure that Dischargers identify and implement corrective actions to maintain high treatment performance and comply with this Order's requirements.

8. PUBLIC PARTICIPATION

The Regional Water Board considered the issuance of WDRs that will serve as an NPDES permit for groundwater treatment facilities in the San Francisco Bay Region. As a step in the WDR adoption process, Regional Water Board staff developed tentative WDRs and encouraged public participation in the WDR adoption process.

- 8.1. Notification of Interested Parties.** The Regional Water Board notified the Dischargers and interested agencies and persons of its intent to prescribe WDRs for the discharge and provided an opportunity to submit written comments and recommendations. The public had access to the agenda and any changes in dates and locations through the Regional Water Board's website at waterboards.ca.gov/sanfranciscobay.

Consistent with Water Code section 189.7, the Regional Water Board notified potentially affected disadvantaged communities and tribal communities of this Order and provided them with an opportunity to engage prior to the public comment period. The Regional Water Board also notified disadvantaged communities and tribal communities of the opportunity to submit written comments during the public comment period.

- 8.2. Environmental Justice.** Water Code section 13149.2 requires the Regional Water Board to make a concise programmatic finding on potential environmental justice, tribal impact, and racial equity considerations for reissued regional WDRs. The Regional Water Board has considered readily available information concerning anticipated water quality impacts in disadvantaged communities and tribal communities that may result from the changes to the permit requirements in this Order. The Regional Water Board has also considered the environmental justice concerns within its authority raised regarding those impacts.

The discharges authorized by this Order will occur across the San Francisco Bay region. There are disadvantaged communities³ and tribal communities⁴ in the region. This Order requires that all discharges immediately comply with applicable water quality objectives; therefore, the nature and location of the discharges under this Order are not expected to impact environmental justice, disadvantaged communities and tribal communities, and racial equity. Nevertheless, Regional

³ Water Code section 13149.2, subdivision (f)(1), defines "disadvantaged community" as "a community in which the median household income is less than 80 percent of the statewide annual median household income level." The statewide annual median household income in the U.S. Census Bureau 2020 Census was \$78,672.6. Based on these data, a community with a household income less than \$62,938 is a "disadvantaged community" as used in section 13149.2.

⁴ Water Code section 13149.2, subdivision (f)(3), defines "tribal community" as "a community within a federally recognized California Native American tribe or nonfederally recognized Native American tribe on the contact list maintained by the Native American Heritage Commission for the purposes of Chapter 905 of the Statutes of 2004."

Water Board staff reached out to consult with disadvantaged and tribal communities regarding this Order before the formal public comment period described in Fact Sheet section 8.3 began.

- 8.3. Written Comments.** Interested persons were invited to submit written comments concerning the tentative WDRs as explained through the notification process. Comments were to be submitted either in person, by email, or by mail to the attention of Marcos De la Cruz.

Written comments were due at the Regional Water Board office by 5:00 p.m. on February 17, 2025.

- 8.4. Public Hearing.** The Regional Water Board held a public hearing on the tentative Order during its regular meeting at the following date and time:

Date: December 10, 2025
Time: 9:00 a.m.
Contact: Marcos De la Cruz, (510) 622-2365,
marcos.delacruz@waterboards.ca.gov

Interested persons were provided notice of the hearing and information on how to participate. During the public hearing, the Regional Water Board heard testimony pertinent to the discharges, and Order.

Dates and venue can change. The Regional Water Board's web address is <https://www.waterboards.ca.gov/sanfranciscobay>, where one can access the current agenda for changes.

- 8.5. Reconsideration of Waste Discharge Requirements.** Any person aggrieved by this Regional Water Board action may petition the State Water Board to review the action in accordance with Water Code section 13320 and California Code of Regulations, title 23, section 2050. The State Water Board must receive the petition at the following address within 30 calendar days of the date of Regional Water Board action:

State Water Resources Control Board
Office of Chief Counsel
P.O. Box 100, 1001 I Street
Sacramento, CA 95812-0100

A petition may also be filed by email at waterqualitypetitions@waterboards.ca.gov.

For instructions on how to file a water quality petition for review, see [waterboards.ca.gov/public_notices/petitions/water_quality/wqpetition_instr.shtml](https://www.waterboards.ca.gov/public_notices/petitions/water_quality/wqpetition_instr.shtml).

- 8.6. Information and Copying.** The Report of Waste Discharge, related supporting documents, and comments received are on file and may be inspected at the Regional Water Board address above by making an appointment with the

Regional Water Board's custodian of records. Document copying may be arranged by calling (510) 622-2300.

- 8.7. Register of Interested Persons.** Any person interested in being placed on the mailing list for information regarding the WDRs and NPDES permit should contact the Regional Water Board, reference the Facility, and provide a name, address, and phone number.
- 8.8. Additional Information.** Requests for additional information or questions regarding this Order should be directed to Marcos De la Cruz, (510) 622-2365, marcos.delacruz@waterboards.ca.gov.

ATTACHMENT G– Priority Pollutants**List of Monitoring Parameters, Analytical Methods, and Minimum Levels (µg/L) ^[1]**

CTR No.	Pollutant / Parameter	Analytical Method ^[2]	GC	GC MS	LC	Color	FAA	GFAA	ICP	ICP MS	SPGF AA	HYD RIDE	CVAA	DCP
1	Antimony	204.2	-	-	-	-	10	5	50	0.5	5	0.5	-	1000
2	Arsenic	206.3	-	-	-	20	-	2	10	2	2	1	-	1000
3	Beryllium	-	-	-	-	-	20	0.5	2	0.5	1	-	-	1000
4	Cadmium	200 or 213	-	-	-	-	10	0.5	10	0.25	0.5	-	-	1000
5a	Chromium (III)	SM 3500	-	-	-	-	-	-	-	-	-	-	-	-
5b	Chromium (VI)	SM 3500	-	-	-	10	5	-	-	-	-	-	-	1000
	Chromium (total) ^[3]	SM 3500	-	-	-	-	50	2	10	0.5	1	-	-	1000
6	Copper	200.9	-	-	-	-	25	5	10	0.5	2	-	-	1000
7	Lead	200.9	-	-	-	-	20	5	5	0.5	2	-	-	10,000
8	Mercury	1631 ^[4]	-	-	-	-	-	-	-	-	-	-	-	-
9	Nickel	249.2	-	-	-	-	50	5	20	1	5	-	-	1000
10	Selenium	200.8 or SM 3114B or C	-	-	-	-	-	5	10	2	5	1	-	1000
11	Silver	272.2	-	-	-	-	10	1	10	0.25	2	-	-	1000
12	Thallium	279.2	-	-	-	-	10	2	10	1	5	-	-	1000
13	Zinc	200 or 289	-	-	-	-	20	-	20	1	10	-	-	-
14	Cyanide	SM 4500 CN ⁻ C or I	-	-	-	5	-	-	-	-	-	-	-	-
15	Asbestos (only required for dischargers to MUN waters) ^[5]	100.2 ^[6]	-	-	-	-	-	-	-	-	-	-	-	-
16	2,3,7,8-TCDD and 17 congeners (Dioxin)	1613	-	-	-	-	-	-	-	-	-	-	-	-
17	Acrolein	603	2.0	5	-	-	-	-	-	-	-	-	-	-
18	Acrylonitrile	603	2.0	2	-	-	-	-	-	-	-	-	-	-
19	Benzene	602	0.5	2	-	-	-	-	-	-	-	-	-	-
20	Bromoform	601	0.5	2	-	-	-	-	-	-	-	-	-	-
21	Carbon Tetrachloride	601	0.5	2	-	-	-	-	-	-	-	-	-	-
22	Chlorobenzene	601	0.5	2	-	-	-	-	-	-	-	-	-	-

CTR No.	Pollutant / Parameter	Analytical Method ^[2]	GC	GC MS	LC	Color	FAA	GFAA	ICP	ICP MS	SPGF AA	HYD RIDE	CVAA	DCP
23	Chlorodibromomethane	601	0.5	2	-	-	-	-	-	-	-	-	-	-
24	Chloroethane	601	0.5	2	-	-	-	-	-	-	-	-	-	-
25	2-Chloroethylvinyl Ether	601	1	1	-	-	-	-	-	-	-	-	-	-
26	Chloroform	601	0.5	2	-	-	-	-	-	-	-	-	-	-
27	Dichlorobromomethane	601	0.5	2	-	-	-	-	-	-	-	-	-	-
28	1,1-Dichloroethane	601	0.5	1	-	-	-	-	-	-	-	-	-	-
29	1,2-Dichloroethane	601	0.5	2	-	-	-	-	-	-	-	-	-	-
30	1,1-Dichloroethylene or 1,1-Dichloroethene	601	0.5	2	-	-	-	-	-	-	-	-	-	-
31	1,2-Dichloropropane	601	0.5	1	-	-	-	-	-	-	-	-	-	-
32	1,3-Dichloropropylene or 1,3-Dichloropropene	601	0.5	2	-	-	-	-	-	-	-	-	-	-
33	Ethylbenzene	602	0.5	2	-	-	-	-	-	-	-	-	-	-
34	Methyl Bromide or Bromomethane	601	1.0	2	-	-	-	-	-	-	-	-	-	-
35	Methyl Chloride or Chloromethane	601	0.5	2	-	-	-	-	-	-	-	-	-	-
36	Methylene Chloride or Dichloromethane	601	0.5	2	-	-	-	-	-	-	-	-	-	-
37	1,1,2,2-Tetrachloroethane	601	0.5	1	-	-	-	-	-	-	-	-	-	-
38	Tetrachloroethylene	601	0.5	2	-	-	-	-	-	-	-	-	-	-
39	Toluene	602	0.5	2	-	-	-	-	-	-	-	-	-	-
40	1,2-Trans-Dichloroethylene	601	0.5	1	-	-	-	-	-	-	-	-	-	-
41	1,1,1-Trichloroethane	601	0.5	2	-	-	-	-	-	-	-	-	-	-
42	1,1,2-Trichloroethane	601	0.5	2	-	-	-	-	-	-	-	-	-	-
43	Trichloroethene	601	0.5	2	-	-	-	-	-	-	-	-	-	-
44	Vinyl Chloride	601	0.5	2	-	-	-	-	-	-	-	-	-	-
45	2-Chlorophenol	604	2	5	-	-	-	-	-	-	-	-	-	-
46	2,4-Dichlorophenol	604	1	5	-	-	-	-	-	-	-	-	-	-
47	2,4-Dimethylphenol	604	1	2	-	-	-	-	-	-	-	-	-	-
48	2-Methyl-4,6-Dinitrophenol or Dinitro-2-methylphenol	604	10	5	-	-	-	-	-	-	-	-	-	-

CTR No.	Pollutant / Parameter	Analytical Method ^[2]	GC	GC MS	LC	Color	FAA	GFAA	ICP	ICP MS	SPGF AA	HYD RIDE	CVAA	DCP
49	2,4-Dinitrophenol	604	5	5	-	-	-	-	-	-	-	-	-	-
50	2-Nitrophenol	604	-	10	-	-	-	-	-	-	-	-	-	-
51	4-Nitrophenol	604	5	10	-	-	-	-	-	-	-	-	-	-
52	3-Methyl-4-Chlorophenol	604	5	1	-	-	-	-	-	-	-	-	-	-
53	Pentachlorophenol	604	1	5	-	-	-	-	-	-	-	-	-	-
54	Phenol	604	1	1	-	50	-	-	-	-	-	-	-	-
55	2,4,6-Trichlorophenol	604	10	10	-	-	-	-	-	-	-	-	-	-
56	Acenaphthene	610 HPLC	1	1	0.5	-	-	-	-	-	-	-	-	-
57	Acenaphthylene	610 HPLC	-	10	0.2	-	-	-	-	-	-	-	-	-
58	Anthracene	610 HPLC	-	10	2	-	-	-	-	-	-	-	-	-
59	Benzidine	625	-	5	-	-	-	-	-	-	-	-	-	-
60	Benzo(a)Anthracene or 1,2 Benzanthracene	610 HPLC	10	5	-	-	-	-	-	-	-	-	-	-
61	Benzo(a)Pyrene	610 HPLC	-	10	2	-	-	-	-	-	-	-	-	-
62	Benzo(b) Fluoranthene or 3,4 Benzofluoranthene	610 HPLC	-	10	10	-	-	-	-	-	-	-	-	-
63	Benzo(ghi)Perylene	610 HPLC	-	5	0.1	-	-	-	-	-	-	-	-	-
64	Benzo(k)Fluoranthene	610 HPLC	-	10	2	-	-	-	-	-	-	-	-	-
65	Bis(2-Chloroethoxy)Methane	625	-	5	-	-	-	-	-	-	-	-	-	-
66	Bis(2-Chloroethyl)Ether	625	10	1	-	-	-	-	-	-	-	-	-	-
67	Bis(2-Chloroisopropyl) Ether	625	10	2	-	-	-	-	-	-	-	-	-	-
68	Bis(2-Ethylhexyl)Phthalate	606 or 625	10	5	-	-	-	-	-	-	-	-	-	-
69	4-Bromophenyl Phenyl Ether	625	10	5	-	-	-	-	-	-	-	-	-	-
70	Butylbenzyl Phthalate	606 or 625	10	10	-	-	-	-	-	-	-	-	-	-
71	2-Chloronaphthalene	625	-	10	-	-	-	-	-	-	-	-	-	-
72	4-Chlorophenyl Phenyl Ether	625	-	5	-	-	-	-	-	-	-	-	-	-
73	Chrysene	625	-	10	5	-	-	-	-	-	-	-	-	-
74	Dibenzo(a,h)Anthracene	610 HPLC	-	10	0.1	-	-	-	-	-	-	-	-	-
75	1,2-Dichlorobenzene	601	0.5	2	-	-	-	-	-	-	-	-	-	-
76	1,3-Dichlorobenzene	601	0.5	2	-	-	-	-	-	-	-	-	-	-
77	1,4-Dichlorobenzene	601	0.5	2	-	-	-	-	-	-	-	-	-	-

CTR No.	Pollutant / Parameter	Analytical Method ^[2]	GC	GC MS	LC	Color	FAA	GFAA	ICP	ICP MS	SPGF AA	HYD RIDE	CVAA	DCP
78	3,3'-Dichlorobenzidine	625	-	5	-	-	-	-	-	-	-	-	-	-
79	Diethyl Phthalate	606 or 625	10	2	-	-	-	-	-	-	-	-	-	-
80	Dimethyl Phthalate	606 or 625	10	2	-	-	-	-	-	-	-	-	-	-
81	Di-n-Butyl Phthalate	606 or 625	-	10	-	-	-	-	-	-	-	-	-	-
82	2,4-Dinitrotoluene	625	10	5	-	-	-	-	-	-	-	-	-	-
83	2,6-Dinitrotoluene	625	-	5	-	-	-	-	-	-	-	-	-	-
84	Di-n-Octyl Phthalate	606 or 625	-	10	-	-	-	-	-	-	-	-	-	-
85	1,2-Diphenylhydrazine ^[7]	625	-	1	-	-	-	-	-	-	-	-	-	-
86	Fluoranthene	610 HPLC	10	1	0.05	-	-	-	-	-	-	-	-	-
87	Fluorene	610 HPLC	-	10	0.1	-	-	-	-	-	-	-	-	-
88	Hexachlorobenzene	625	5	1	-	-	-	-	-	-	-	-	-	-
89	Hexachlorobutadiene	625	5	1	-	-	-	-	-	-	-	-	-	-
90	Hexachlorocyclopentadiene	625	5	5	-	-	-	-	-	-	-	-	-	-
91	Hexachloroethane	625	5	1	-	-	-	-	-	-	-	-	-	-
92	Indeno(1,2,3-cd)Pyrene	610 HPLC	-	10	0.05	-	-	-	-	-	-	-	-	-
93	Isophorone	625	10	1	-	-	-	-	-	-	-	-	-	-
94	Naphthalene	625	10	1	0.2	-	-	-	-	-	-	-	-	-
95	Nitrobenzene	625	10	1	-	-	-	-	-	-	-	-	-	-
96	N-Nitrosodimethylamine	625	10	5	-	-	-	-	-	-	-	-	-	-
97	N-Nitrosodi-n-Propylamine	625	10	5	-	-	-	-	-	-	-	-	-	-
98	N-Nitrosodiphenylamine	625	10	1	-	-	-	-	-	-	-	-	-	-
99	Phenanthrene	625	-	5	0.05	-	-	-	-	-	-	-	-	-
100	Pyrene	610 HPLC	-	10	0.05	-	-	-	-	-	-	-	-	-
101	1,2,4-Trichlorobenzene	625	1	5	-	-	-	-	-	-	-	-	-	-
102	Aldrin	608	0.005	-	-	-	-	-	-	-	-	-	-	-
103	α -BHC	608	0.01	-	-	-	-	-	-	-	-	-	-	-
104	β -BHC	608	0.005	-	-	-	-	-	-	-	-	-	-	-
105	γ -BHC (Lindane)	608	0.02	-	-	-	-	-	-	-	-	-	-	-
106	δ -BHC	608	0.005	-	-	-	-	-	-	-	-	-	-	-
107	Chlordane	608	0.1	-	-	-	-	-	-	-	-	-	-	-

CTR No.	Pollutant / Parameter	Analytical Method ^[2]	GC	GC MS	LC	Color	FAA	GFAA	ICP	ICP MS	SPGF AA	HYD RIDE	CVAA	DCP
108	4,4'-DDT	608	0.01	-	-	-	-	-	-	-	-	-	-	-
109	4,4'-DDE	608	0.05	-	-	-	-	-	-	-	-	-	-	-
110	4,4'-DDD	608	0.05	-	-	-	-	-	-	-	-	-	-	-
111	Dieldrin	608	0.01	-	-	-	-	-	-	-	-	-	-	-
112	Endosulfan (alpha)	608	0.02	-	-	-	-	-	-	-	-	-	-	-
113	Endosulfan (beta)	608	0.01	-	-	-	-	-	-	-	-	-	-	-
114	Endosulfan Sulfate	608	0.05	-	-	-	-	-	-	-	-	-	-	-
115	Endrin	608	0.01	-	-	-	-	-	-	-	-	-	-	-
116	Endrin Aldehyde	608	0.01	-	-	-	-	-	-	-	-	-	-	-
117	Heptachlor	608	0.01	-	-	-	-	-	-	-	-	-	-	-
118	Heptachlor Epoxide	608	0.01	-	-	-	-	-	-	-	-	-	-	-
119-125	PCBs: Aroclors 1016, 1221, 1232, 1242, 1248, 1254, 1260	608	0.5	-	-	-	-	-	-	-	-	-	-	-
126	Toxaphene	608	0.5	-	-	-	-	-	-	-	-	-	-	-

Footnotes:

- ^[1] Minimum levels are from the *State Implementation Policy*. They are the concentration of the lowest calibration standard for that technique based on a survey of contract laboratories. Laboratory techniques are defined as follows: GC = Gas Chromatography; GCMS = Gas Chromatography/Mass Spectrometry; LC = High Pressure Liquid Chromatography; Color = Colorimetric; FAA = Flame Atomic Absorption; GFAA = Graphite Furnace Atomic Absorption; ICP = Inductively Coupled Plasma; ICPMS = Inductively Coupled Plasma/Mass Spectrometry; SPGFAA = Stabilized Platform Graphite Furnace Atomic Absorption (i.e., U.S. EPA 200.9); Hydride = Gaseous Hydride Atomic Absorption; CVAA = Cold Vapor Atomic Absorption; DCP = Direct Current Plasma.
- ^[2] The suggested method is the U.S. EPA Method unless otherwise specified (SM = Standard Methods). The Discharger may use another U.S. EPA-approved or recognized method if that method has a level of quantification below the applicable water quality objective. Where no method is suggested, the Discharger has the discretion to use any standard method.
- ^[3] Analysis for total chromium may be substituted for analysis of chromium (III) and chromium (VI) if the concentration measured is below the lowest hexavalent chromium criterion (11 ug/l).
- ^[4] The Discharger shall use ultra-clean sampling (U.S. EPA Method 1669) and ultra-clean analytical methods (U.S. EPA Method 1631) for mercury monitoring. The minimum level for mercury is 2 ng/l (or 0.002 ug/l).
- ^[5] MUN = Municipal and Domestic Supply. This designation, if applicable, is in the Findings of the permit.
- ^[6] Determination of Asbestos Structures over 10 [micrometers] in Length in Drinking Water Using MCE Filters, U.S. EPA 600/R-94-134, June 1994.
- ^[7] Detected as azobenzene.