

RECLAMATION

Managing Water in the West

PAP-1050

**Emerging Challenges and Opportunities for Irrigation Managers
Albuquerque, New Mexico — April 26-29, 2011**

Venturi Meters Constructed with Pipe Fittings: An Under-Appreciated Option for Measuring Agricultural Water

By Tom Gill, Brian Wahlin, and John Replogle



**U.S. Department of the Interior
Bureau of Reclamation
Technical Service Center
Hydraulic Investigations and Laboratory Services Group
Denver, Colorado**

Venturi Meters Constructed with Pipe Fittings: An Under-Appreciated Option for Measuring Agricultural Water

Tom Gill¹
Brian Wahlin²
John Replogle³

ABSTRACT

Increasing competition for limited water supplies, improved technology for managing water delivery systems, and a growing importance in being able to document use of water supplies are all factors driving interest in establishing the capability to measure flow at an expanded number of locations in agricultural water delivery systems. Pipe Venturi meters are widely recognized as a measurement technology in piped systems offering a high degree of accuracy while imposing comparatively small head loss. Researchers at the Agricultural Research Service have documented their efforts in using off-the-shelf PVC fittings to produce “constructed Venturi meters” as a low-cost option for measuring water in agricultural systems. These devices can achieve an accuracy on the order of $\pm 2\%$ for a cost of about \$180.

Despite many attractive attributes of this flow measurement concept, this technology has seen a limited degree of adoption. This paper examines field installations where constructed Venturi meters have been used to measure flows over a range of magnitudes and under a variety of data collection methodologies using a case study format. Guidelines for construction and installation are also presented.

INTRODUCTION

Replogle and Wahlin (1994) introduced the idea of creating low head loss Venturi meters constructed from plastic pipe fittings. True Venturi meters do not have stagnant zones, are more tolerant of upstream conditions, have lower head loss, avoid fouling problems, and are more accurate than most other meters. However, true Venturi meters are quite pricey and are typically beyond the means of most irrigation districts. The plastic pipe fitting Venturi meters suggested by Replogle and Wahlin (1994) avoid the issue of high cost while maintaining the other benefits associated with Venturi meters. The original paper described experiments in which 15 Venturi-type meters were constructed using plastic pipe fittings that had symmetrical configurations (i.e., similar converging and diverging cones). By reversing flow through the meters, 30 configurations were available to assess the construction capability to make appropriate piezometer taps that responded the same to flow in either direction. With the 30 Venturi meters, an attempt was made to evaluate the statistical variability due to construction techniques and manufacturing

¹ Hydraulic Engineer, US Bureau of Reclamation Hydraulic Investigations and Laboratory Services Group, PO Box 25007 Denver, CO 80225, tgill@usbr.gov

² Senior Hydraulic Engineer, WEST Consultants, Inc., 8950 S. 52nd Street, Suite 210, Tempe, AZ 85284, bwahlin@westconsultants.com

³ Retired

differences in commercially available plastic pipe fittings. The results of the experiments indicated that the Venturi meters could be constructed for about \$180 and could be constructed in about 2 hours. Using a standardized rating curve developed as part of the experiments, the accuracy of these meters is approximately $\pm 2\%$, not including the errors associated with the readout method.

THEORY

Venturi meters represent one of the oldest and most reliable of the differential head meters. These devices are well defined in the literature and little new information is available (see ASME (1971) and Brater et al. (1996) for a more complete treatment). Certain angles of convergence and divergence must be observed for standard Venturi-meter behavior. The conduit walls should converge at about 20° and diverge on the downstream side at about 5 to 7° . The approach piping requirements are similar to those for orifices; however, they can be relaxed somewhat with few detrimental effects. A frequently used Venturi meter is the Herschel-type Venturi tube. It has a converging cone of $21^\circ \pm 1^\circ$ and a diverging cone of 7 to 8° (see Figure 1). The throat length of these meters is equal to the throat diameter. This is considered by many users to be the “standard” or “classical” Venturi meter. The angle of the diverging cone does not influence the calibration coefficient, but it does have an effect on the overall head loss through the tube. Commercially produced Venturi meters claim a primary device accuracy of $\pm 0.5\%$ (ASME, 1971).

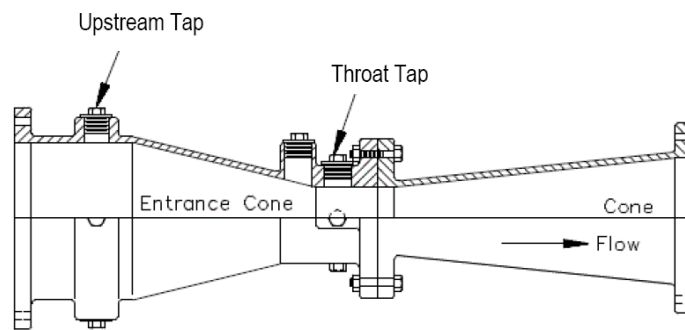

Figure 1. Schematic Diagram of a Standard Venturi Meter

The basic expression for discharge, Q , is derived from the classical Bernoulli Equation and can be written in a form that is applicable to round pipes or other conduit shapes as:

$$Q = C_d \frac{A_p A_t}{\sqrt{A_p^2 - A_t^2}} \sqrt{\frac{2g}{\alpha} (h_p - h_t)}$$

where C_d = discharge coefficient (typically between 0.96 and 0.99 for standard

Venturi meters)

- A_p = area of approach piping
- A_t = area of contracted throat section
- g = gravitational constant
- α = velocity distribution coefficient (assumed to be 1.02)
- h_p = upstream pressure tap reading
- h_t = throat pressure tap reading

EXPERIMENTAL SETUP

A schematic diagram of the plastic pipe Venturi meter is shown in Figure 2. These devices were constructed using commercially available PVC pipe and fittings. The total construction cost is about \$180 US (2010) for the materials plus the cost of about two hours of labor. Once the meters were constructed, they were calibrated using a weigh-tank-and-timer system that is accurate to about $\pm 0.1\%$. Initially, three Venturi meters were constructed with different throat lengths to determine the optimal throat length. In addition, there were two types of converging fittings that were tested: one with 15° contraction and one with a 25° contraction. The need for multiple pressure taps around the throat section was assessed by installing four pressure taps at 90° intervals around the center of the throat section. These taps were hydraulically connected for one series of tests, to give an average pressure reading for the group. Next, they were grouped into two opposite pairs, and, finally, they were separated and read individually. Once the throat length and pressure tap locations were determined, 12 more meters were constructed and calibrated. All the meters then had the flow direction reversed and were calibrated again. Thus, the 30 unique calibrations obtained from the various Venturi meters were used to determine the scatter of calibration for these plastic devices.

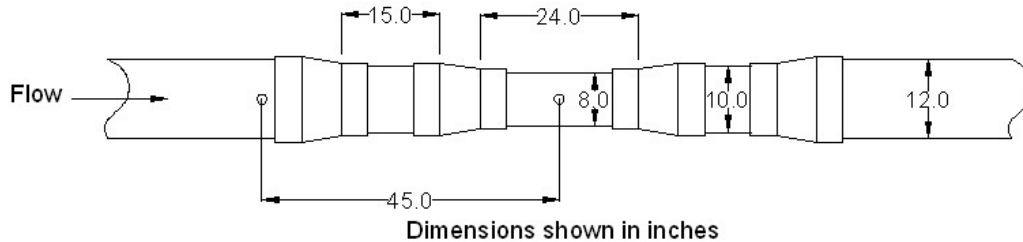

Figure 2. Schematic Diagram of Plastic Fitting Venturi Meter

EXPERIMENTAL RESULTS AND MANUFACTURING RECOMMENDATIONS

Plastic pipe fittings of the kind usually used by the irrigation industry can be fashioned into suitable Venturi meters with an expected accuracy of $\pm 2\%$, not including the errors of the readout method. The discharge coefficient for the plastic fitting Venturi meter is given by:

$$C_d = 0.964 - 0.0466e^{(-R_n/254,000)}$$

where C_d is the discharge coefficient and R_n is the Reynolds Number based on pipe diameter. The experimental discharge coefficients for the plastic pipe Venturi meters ranged from about 0.92 to 0.96, slightly less than the discharge coefficients for true Venturi meters. Other conclusions from Replogle and Wahlin (1994) include:

- It is recommended that a throat length of three times the throat diameter be used for plastic Venturi meter construction. Shorter throat lengths appear to cause difficulties in pressure detection due to flow separation. Longer throat lengths produce excessive head loss.
- The rate of contraction of the reducer fittings (i.e., 15° versus 25°) caused no significant change in C_d , and thus the meter calibration. However, the fittings with the 25° contraction rate exhibited a greater total head loss through the meter than those with the less severe 15° contraction rate.
- The most important construction factor is the fabrication of the pressure taps and the immediate connections. They should be drilled with appropriate backing blocks to reduce burrs and with a guide to assure that they are constructed perpendicular to the pipe wall. It is recommended that the pressure taps be installed on the sides of the meter to prevent air bubbles from entering the pressure lines. It is not necessary that the pressure taps be on the same horizontal line and the meter can be mounted at any angle.
- Slow-setting PVC cement should be used to allow workers sufficient time to uniformly assemble and adjust large pipe parts.
- The cost of pipeline parts is within the economic range of most irrigation applications. [Costs are about \$180 U.S. (2010) for the pipe and fittings, plus about two hours of labor, per meter.]

FIELD INSTALLATION CASE STUDIES

Three field installation case studies are presented that show the versatility of pipe-fitting Venturi systems for measuring flow either as stand-alone low-tech installations, or as part of an automated data collection network. The first two case studies presented document field demonstration projects that were established to examine performance over time in terms of reliability and long-term cost effectiveness. The third case study included is a brief discussion of a temporary measurement installation where a pipe-fitting venturi was utilized to measure flow as part of an irrigation research project.

Pioneer Irrigation District: The Pioneer Irrigation District (PID) diverts flow from the North Fork Republican River in Yuma County, CO and has historically delivered irrigation water to farmlands in extreme eastern Yuma County and in western Dundy County, NE. During the 2003 and 2004 irrigation seasons, the Water Conservation Field Services Program of Reclamation's Nebraska-Kansas Area Office (NKAO) arranged for engineers from Reclamation's Hydraulic Investigation and Laboratory Services group (HILS) in Denver, CO to provide technical assistance to the PID in establishing flow measurement capability at each operating farm turnout.

Site-specific constraining conditions dictated use of multiple flow measurement technologies in the project. The pipe-fitting Venturi system developed by Replogle and Wahlin (1994) was proposed to PID as a cost-effective measurement option that may be applicable for some of the PID turnouts. PID agreed to work with HILS engineers to set up a demonstration site using a pipe-fitting Venturi.

The site selected for the demonstration project featured a 12 in. pipe turnout from the PID canal. A pipe-fitting Venturi was constructed using PVC bell reducer fittings in a configuration similar to that shown in Figure 2 to reduce from 12 in. to 10 in. then from 10 in. to an 8 in. diameter Venturi throat. Downstream from the throat the pipe was expanded through two steps back to 12 in. diameter using a mirror image configuration of the fittings used for the contraction. Metering taps were installed in the 12 in. pipe just upstream of the initial reducing fitting, and at mid-length of the throat section. For the demonstration site, a third tap was installed in the downstream section after pipe diameter was expanded back to 12 in. as a means of showing the head loss through the meter. Figure 3 shows the installation of the venturi meter at PID the demonstration site.



Figure 3. PID Ditch Rider Dennis Waggoner (l) and Ditch Superintendant Dan Korf (r) assisting with the May, 2003 pipe-fitting Venturi demonstration site installation

A specialized manometer board was fabricated for the PID demonstration site that featured a sliding scale. The scale was marked to show head differential in feet and also to show flow rate in gallons-per-minute (the flow rate measurement units historically utilized by PID). To determine flow rate or head differential, the sliding scale would be raised until the zero line on the scale was even with the height of water in the low pressure manometer tube linked to the throat tap. Flow rate and head differential could then be read as the values from the respective scales that lined up with the water level manometer linked to the higher pressure upstream section tap. A manometer tube attached to the downstream tap was installed on the manometer board adjacent to the upstream manometer tube. Comparison of water levels in the upstream and downstream tubes provided visual evidence of head loss experienced by flow passing through the Venturi meter. Figure 4 shows the manometer board at the PID demonstration site.



Figure 4. PID demonstration pipe-fitting Venturi and manometer

Flow conditions being measured in Figure 4 show an approximate 800 gpm flow rate with meter head loss of ~ 0.35 ft. The throat tap plumbing may be seen near the bottom of Figure 4. A tee fitting at the tap is oriented such that a valve is installed in the branch of the tee oriented normal to the Venturi throat while the manometer line leaves the tee in a direction parallel to the throat. With this configuration, the valve on the end of the tee may be opened to allow insertion of a thin rod or wire to clean debris that may clog the pressure tap from time to time with this canal-fed system.

HILS engineers and PID staff agreed that the pipe fitting Venturi meter demonstration showed that the technology is cost competitive, can provide suitable flow measurement accuracy, and imposes comparatively modest head requirements. The land-owner whom this turnout served however could not be convinced that the 12 in. to 8 in. pipe size reduction was not severely limiting his ability to receive water from the canal. A short time after the Venturi demonstration site was set up the land owner removed it and installed a suppressed rectangular weir which required a water surface level drop in the range of one foot for non-submerged operation.

At the request of PID staff, the PVC Venturi meter was later re-installed in 2004 at a different turnout. The new location was higher in the PID delivery system within the Colorado delivery area. Figure 5 shows re-installed Venturi.



Figure 5. PVC Venturi meter and manometer installed at the second PID site

At the second installation site the PID canal outflow pipe previously discharged into a concrete lined field canal. The Venturi meter had to be installed on top of the canal lining. The “dog leg” configuration of two 45° pipe bends that served to raise discharge to a suitable discharge height for the initial demonstration site shown in Figure 4 was also utilized at this site to ensure pipe-full flow through the Venturi. There is sufficient head available at this site to maintain the normal delivery flow rate. As may be seen in Figure 5 the fall from the “dog leg” represents a significantly greater head loss than the measured ~ 0.35 ft head loss through the Venturi meter discussed above.

Flow measurement with the PVC Venturi meter at the second PID site was also fated to a limited time of operation. Ramifications from a US Supreme Court case on water usage in the Republican Basin involving Colorado, Nebraska and Kansas has led Colorado

Republican Basin well users to seek augmentation water to offset stream-flow injury resulting from well operations. Beginning in 2008 the Colorado irrigators on the PID system have entered a long-term lease for use of their share of PID water to an upstream well-users group and for the present have discontinued their PID irrigation operations. It is unclear whether this turnout will again be in service.

Mohave Valley Irrigation District: The Mohave Valley Irrigation and Drainage District (MVIDD) lies in Arizona along the east bank of the Colorado River a short distance downstream from the southern tip of Nevada. All water utilized by the district is pumped from the shallow groundwater aquifer fed by the river, and is administered as diversion from the Colorado River. MVIDD had encountered problems with a range of previously tried flow meter technologies due in a large part to high concentrations of iron oxide present in the pumped flows.

In 2008, the Water Conservation Field Services Program of Reclamation's Yuma Area Office (YAO) requested technical assistance from HILS to identify cost-effective flow measurement methods that could function reliably over time given the water quality issues present along with other site-specific constraints at MVIDD. An automated data collection system was also a desired capability for the flow measurement system capability. YAO and MVIDD agreed to set up a demonstration site configured with a pipe fitting Venturi as a preliminary step in design of a flow measurement system. Figure 6 shows the MVIDD demonstration site.



Figure 6. MVIDD pipe fitting venturi meter demonstration site

Interest in the pipe-fitting Venturi meter concept was based on comparatively low installation costs, lack of moving parts, and relatively low head requirements. Keeping pressure tap orifices un-obstructed would be a concern given water quality conditions at MVIDD. As a means of keeping tap orifices cleared, a prototype sensing system utilizing a bubbler sensor linked to a solenoid valve bank was configured. Operation of the bubbler and solenoid valves was controlled by a programmable RTU that has on-site datalogging capability along with a radio communications link to a base unit at the MVIDD office. The RTU, bubbler and solenoid valve equipment may be seen in the electrical enclosure in the foreground of Figure 6.

The MVIDD demonstration site differed from the Replogle-Wahlin design sketch shown in Figure 2 in two key respects. First, the existing 12 in. pump discharge pipe was reduced by only one pipe size to 10 in. (as opposed to the double reduction to 8 in. pipe as shown in Figure 2 and as employed with the PID Venturi meter). The demonstration site well motor is always operated at the same speed and produces a comparatively high discharge for the pipe size ($\sim 9 \text{ ft}^3/\text{s}$). For the near-constant discharge at this site, a suitable pressure differential may be observed for appropriate measurement resolution with the single drop in pipe size.

The second design deviation was the absence of an expansion section back to the original 12 in. pipe size downstream from the Venturi meter. A downstream expansion can be a means of converting much of the increased dynamic (velocity) head seen in the reduced diameter pipe of the Venturi throat back to static (pressure) head. The lack of an expansion and associated increased discharge velocity results in an increased energy loss but does not impact flow measurement. For limited-term operation as a field test, an expansion section was not initially installed at this site.

Measured discharge rate at the MVIDD demonstration site was compared against a flow measurement obtained using a stream gage technique with a Price type AA current meter in the downstream canal. Agreement between the Venturi measured flow and the stream gage measured flow were found to be within the accuracy limits of the stream gage measurement.

The MVIDD demonstration site has now been in operation for approximately 30 months. Over this period of operation, the bubbler-sensed Venturi has experienced no maintenance issues or interruptions in service. This technology appears to be suitable for maintaining flow measurement capability with the water quality problems present which have proven problematic for multiple previously tested meter technologies at MVIDD. Following the initial 6 months of “field test” operations a pipe expansion section was added to the venturi meter at this site.

Palo Verde Irrigation District Deficit Irrigation Study: During 2008, a University of California Cooperative Extension Service field study examining impacts of deficit irrigation on alfalfa under the direction of Dr. Khaled Bali was being conducted at Palo Verde Irrigation District. As part of this study, a cost effective means of measuring field runoff of irrigation water was needed. Dr. Bali contacted Mark Niblack, the Water

Conservation Field Services Program Coordinator at Reclamation's Yuma Area Office for assistance in measuring the field runoff flows.

Runoff from the test field is conveyed under a field road through a pipe culvert that discharges into a drain canal on the opposite side of the road. This culvert pipe entrance is several inches below the grade of the alfalfa field. An elevation survey of the culvert pipe revealed a slight upwards slope of the pipe that would ensure pipe full flow at the inlet any time water is being discharged into the drain. With pipe full flow assured, a Venturi constructed of pipe fittings installed on the drain culvert inlet was suggested for measuring the irrigation runoff at this site.

Figure 7 and Figure 8 show the pipe-fitting Venturi and solar powered datalogging system being installed to measure and record field runoff. A small solar charging system was set up to power a differential pressure transducer linked to a datalogger at the site.



Figure 7. Runoff measurement venturi at Palo Verde



Figure 8. Installation of logging system at Palo Verde runoff venturi

SUMMARY

Venturi meters constructed of pipe fittings can be a practical means of measuring flow with reliable accuracy for a range of applications. As presented in the field demonstration sites cited above, the technology can be configured as low-tech stand alone measurement sites based on reading water column elevations, or may be readily incorporated into an automated data collection or SCADA system. While the pipe fitting venturi meters are by definition a closed conduit measurement instrument, it may be feasible to install one in an intermediate closed conduit link in what is essentially an open channel conveyance system. For all applications, pipe-full flow must be ensured as flow passes through the Venturi section.

Increased head loss in the downstream expansion section may be measurably greater with a pipe fitting Venturi than for an engineered Venturi. However in comparison with numerous other commonly employed measurement structures in agricultural water systems, the pipe fitting Venturi head losses are comparatively small. For water districts with the in-house fabrication and installation capabilities, pipe fitting Venturi meters can represent a cost competitive measurement alternative in comparison alternative flow measurement technologies including commercially available Venturi products.

None of the demonstration site case studies presented cover a time span that would approach a desired life expectancy for operation of a flow measurement system. Thus assessment of long-term reliability and cost effectiveness would require some degree of extrapolation. Given the extremely basic functionality of Venturi meters, along with fact that the Venturi solution for measuring flow is an analytic (as opposed to a calibrated) relationship, expectations for an appealing life expectancy should be quite high. Pipe fitting Venturi meters are a technology that should be factored into the thinking of any water delivery entity seeking an economical means of expanding flow measurement capabilities.

Additional items of interest regarding use of venturi meters that are not brought out in the case studies cited are worth noting: Venturi meters do not require horizontal installation. The static head components that may be measured as a water column at the respective upstream and throat cross sections represent a combination of pressure head and elevation head. For an installation where Venturi taps are not in the same horizontal plane an increase (or decrease) in pressure heads (compared with a horizontal installation) is exactly offset by the differing elevation heads. Thus the measured water columns for either case will be the same.

When manometers are used to measure Venturi static heads, the manometers do not necessarily need to be vented to atmospheric pressure. A manometer system may be constructed with the tops of both the upstream and Venturi throat manometer tubes plumbed together in a manner that allows an increase in air pressure or a vacuum pressure to be present above the water column surfaces. Adjusting air pressure above the water surfaces with this manometer configuration allows the water columns to be read at

a more convenient level than would be the case for manometers vented to the atmosphere.

Actual head loss through a Venturi meter is commonly quite small compared with opportunities for head recovery that might exist at a pipe exit. As an example, for the site shown in Figure 6, addition of pipe fittings to create an underwater discharge would enable a recovery of static head currently being lost that could easily represent an amount several times the head requirement presented by the Venturi meter.

REFERENCES

- American Society of Mechanical Engineers. (1971). *Fluid Meters: Their Theory and Application* (6th ed.). (H. S. Bean, Ed.) New York, NY: American Society of Mechanical Engineers.
- Brater, E. F., King, H. W., Lindell, J. E., & Wei, C. Y. (1996). *Handbook of Hydraulics* (7th ed.). Boston, MA: McGraw Hill.
- Repogle, J. A., & Wahlin, B. T. (1994). Venturi Meter Constructions for Plastic Irrigation Pipelines. *Applied Engineering in Agriculture* , 10 (1), 21-26.